



U.S. Department
of Transportation

**Federal Highway
Administration**

March 17, 2005

400 Seventh St., S.W.
Washington, D.C. 20590

In Reply Refer To: HSA-10/CC-89

Dean C. Alberson, Ph.D., P.E.
Associate Research Engineer
Texas Transportation Institute
3135 TAMUS
College Station, Texas 77843-3135

Dear Dr. Alberson:

In your February 26, 2005, letter, you requested the Federal Highway Administration's acceptance of a new reusable, redirective crash cushion called the Hybrid Energy Absorbing Reusable Terminal (HEART) at the National Cooperative Highway Research Program (NCHRP) Report 350 test level 3 (TL-3). To support your request, you also sent copies of a Texas Transportation Institute report dated January 2004, entitled "Testing and Evaluation of the HEART Crash Cushion," and videotapes of three crash tests you conducted on the new design. After initial staff review of the reported tests, we requested two additional tests, the results of which were sent to me on March 3 with a second Texas Transportation Institute report dated March 2005, entitled "NCHRP Report 350 Tests 3-33 and 3-37 of the HEART".

The HEART attenuator consists of three deformed (hinged) High Molecular Weight/High Density Polyethylene (HMW/HDPE) panels along each side connected to steel diaphragms mounted on tubular steel tracks. The assembled unit is approximately 26-feet long, 32-inches high, 25-inches wide at the diaphragms with a maximum width of 39 inches between diaphragms 3 and 4. The front anchorage consists of a W8 x 13 upper release post mounted to a 1/2-inch thick base plate. There are two slots at the slip plane between the upper and lower post through which tensioning cables are anchored. When the upper release post is impacted, the tensioned cables connected to diaphragm 2 are released and the side panels and steel diaphragms are pushed rearward along the base track. This track consists of a pair of 2 inch x 5 inch x 1/4 inch structural tubes stitch-welded above two C3 x 4.1 standard channels. The channels serve as spacers allowing the diaphragms to move longitudinally along the structural tubing during frontal impacts. Anchor bolts, 3/4-inch diameter x 11-inches long, are placed through the structural tubing and channel at locations that can be accessed without removal of the plastic side panels or diaphragms and into 8-inch thick non-reinforced concrete. The rear backup structure is an 8 inch x 12 inch x 1/2 inch structural tube welded to a 3/4-inch thick base plate. The last diaphragm (#10) is bolted to the structural tube. A second set of tensioning cables, attached to diaphragm 2, terminate on the rear side of diaphragm #10. Enclosure 1 shows the general layout of the unit and selected components.



Based on staff review of the results of the five NCHRP Report 350 tests that were conducted (and summarized in Enclosure 2), I agree that the HEART attenuator, as described above, meets the appropriate evaluation criteria for a TL-3 crash cushion. Since no transition design has yet been developed for a reverse direction hit and Report 350 Test 3-39 was not conducted, the HEART should not be used in locations where opposite-direction impacts are probable without further development and testing. However, the HEART may be used at all appropriate locations on the National Highway System when selected by the contracting authority, subject to the provisions of Title 23, Code of Federal Regulations, Section 635.411 as they pertain to proprietary products.

Sincerely yours,

/Original Signed by/

~for~

John R. Baxter, P.E.
Director, Office of Safety Design
Office of Safety

2 Enclosures

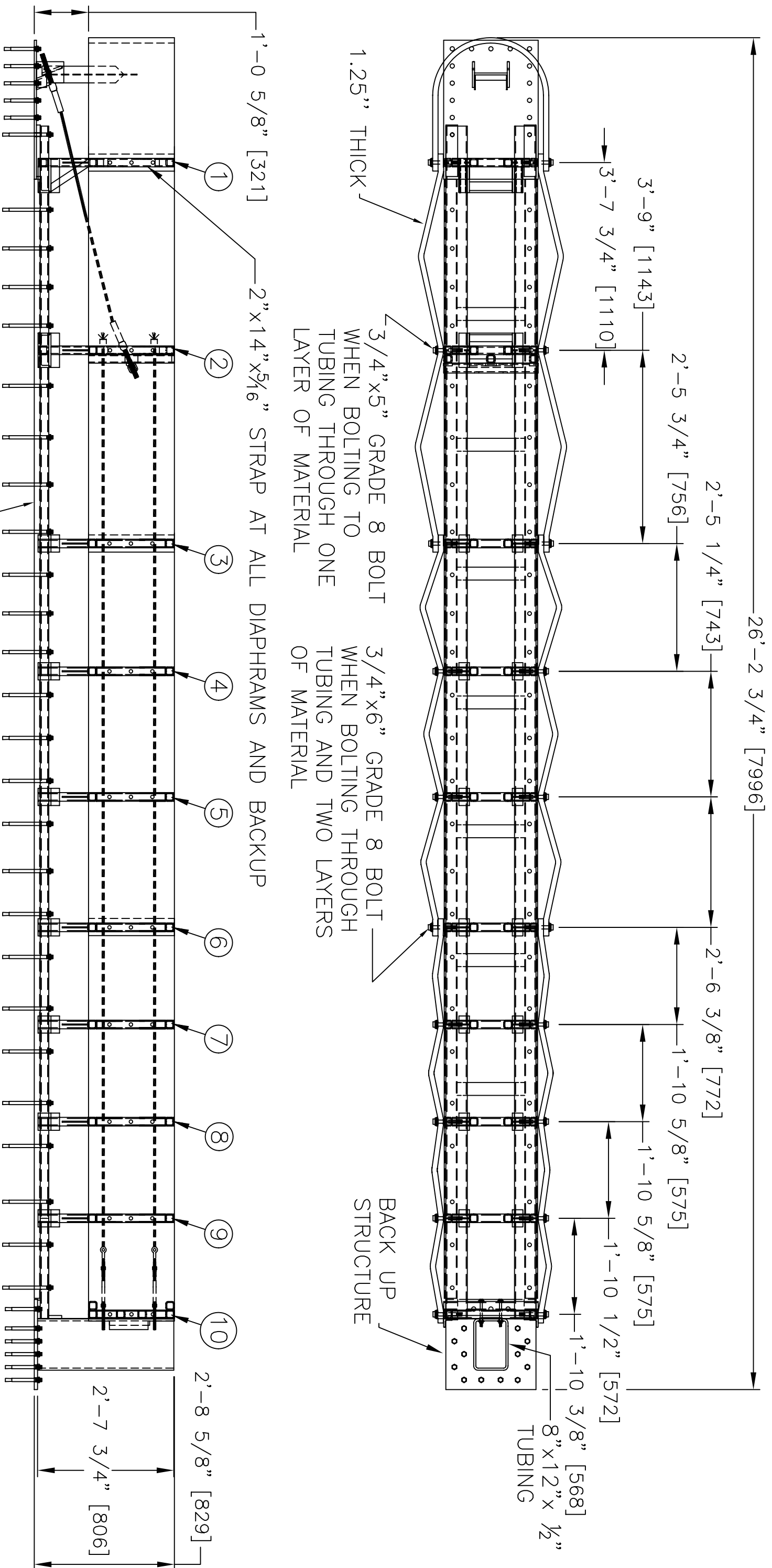

1.25" THICK

3/4"x5" GRADE 8 BOLT WHEN BOLTING TO TUBING THROUGH ONE LAYER OF MATERIAL

3/4"x6" GRADE 8 BOLT WHEN BOLTING THROUGH TUBING AND TWO LAYERS OF MATERIAL

BACK UP STRUCTURE

8"x12"x 1/2" TUBING

1"x2" CHANNEL RUNNING BENEATH TRACK TO ACT AS SPACER

NOTE:
 USE 1 1/2"x3/4" ANCHORS FOR ANCHORS INSERTED INTO 2"x5" TUBING
 USE 8-1/2"x3/4" ANCHORS FOR ANCHORS INSERTED INTO 3/4" AND 1/2" PLATE

Revisions				Title		
No.	Date	By		BOLT PLACEMENT		
1.	12/11/01	BAS		TEXAS TRANSPORTATION INSTITUTE		
2.	12/12/01	BAS		COLLEGE STATION, TEXAS 77843		
3.	12/20/01	BAS		Project No. 220571		
4.	4/18/02	CRM		Date 07/01		
5.	11/20/04	CRM		Drawn By BAS		
				Scale		
				Sheet No. 1 of 9		

The Texas A&M University System

TEXAS TRANSPORTATION INSTITUTE
 COLLEGE STATION, TEXAS 77843

Project No. 220571

Date 07/01

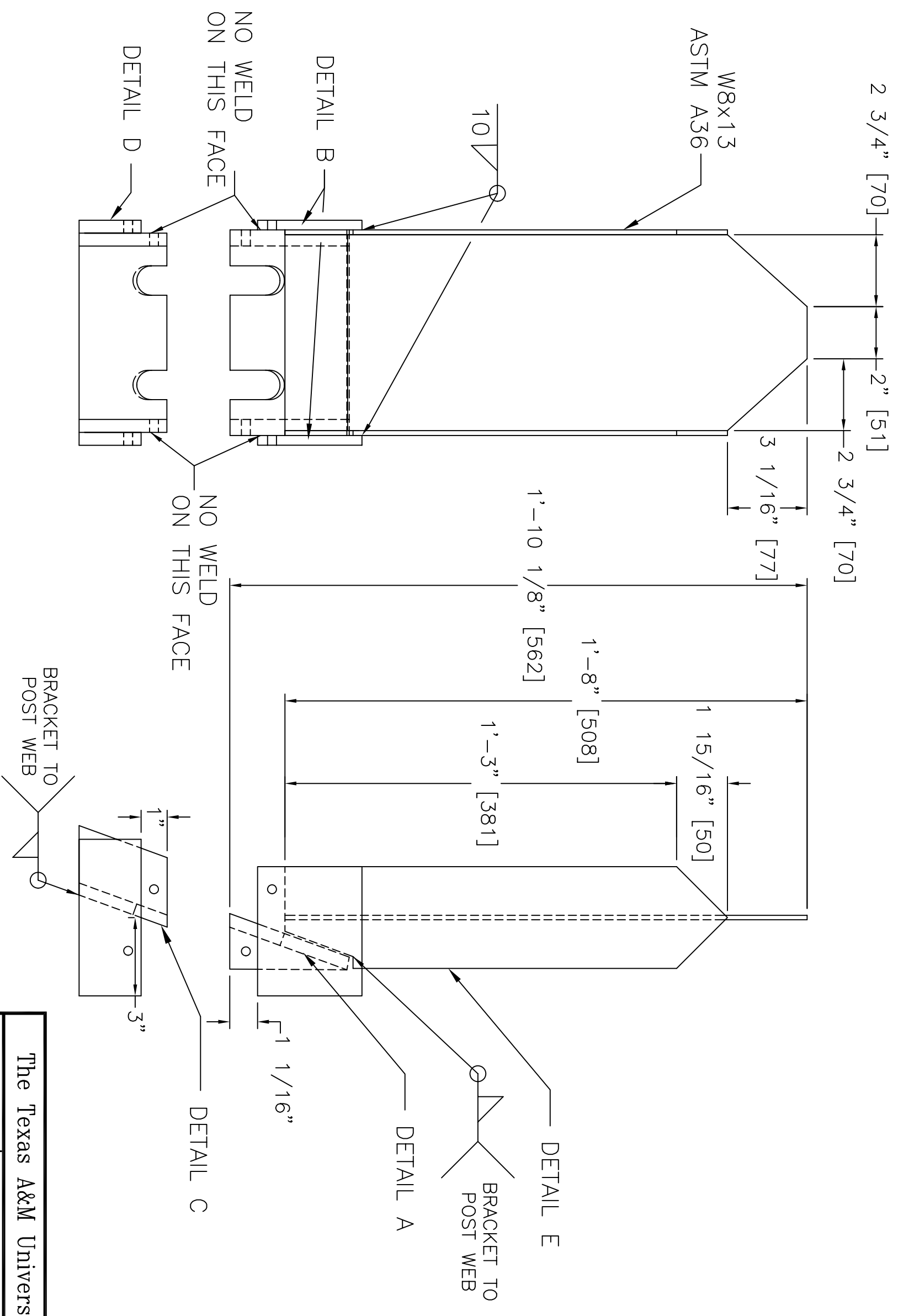

BREAK AWAY POST DETAIL

The Texas A&M University System				
Revisions				
No.	Date	By	Title	
1.	12/11/01	BAS	TEXAS TRANSPORTATION INSTITUTE COLLEGE STATION, TEXAS 77843	
2.	12/12/01	BAS	Project No. 220571	Date 07/01
3.	12/20/01	BAS	Drawn By BAS	Scale
4.	4/3/02	CRM	HEART CRASH CUSHION	
5.	12/9/03	CRM	Sheet No. 5 of 9	

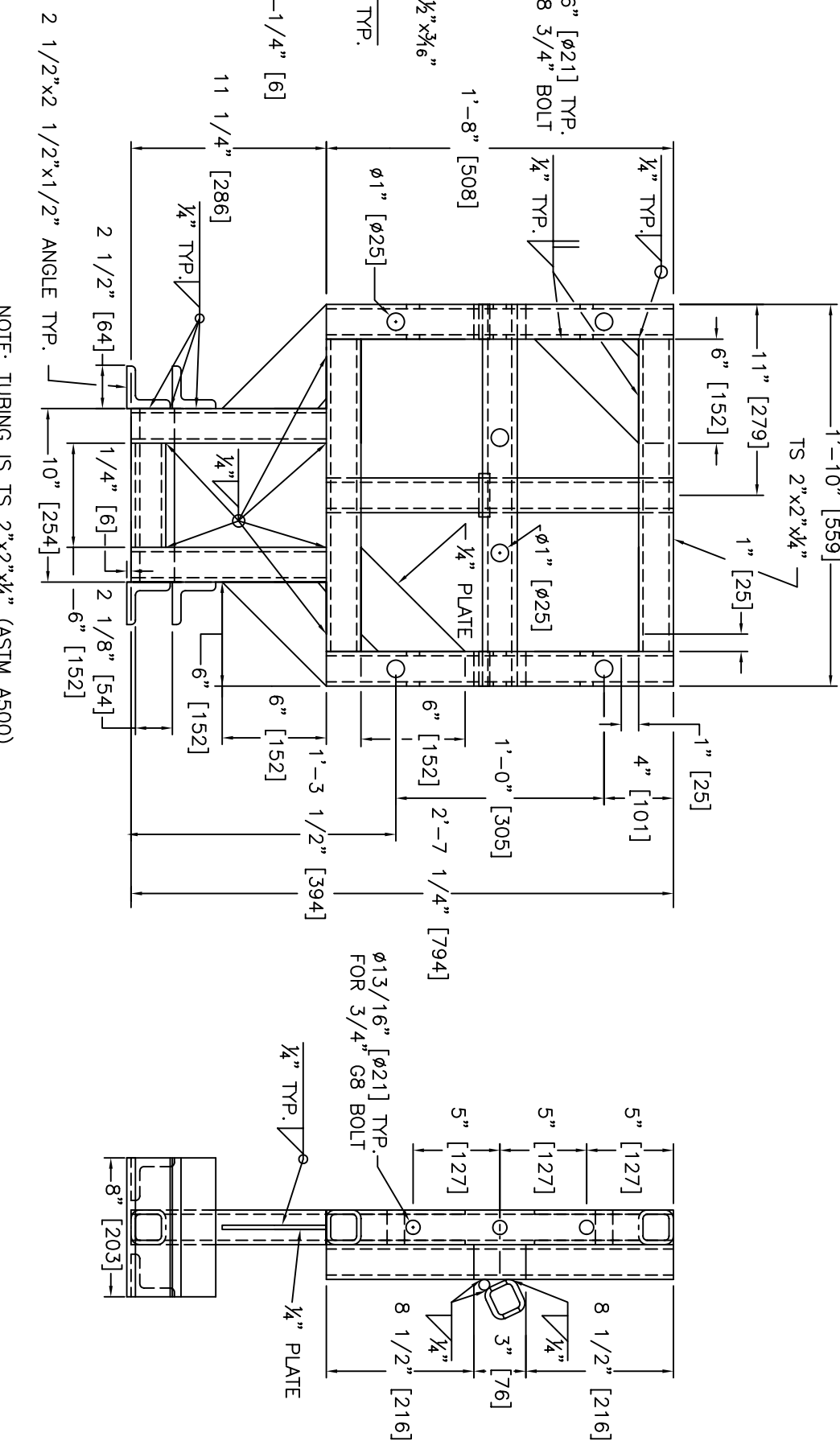
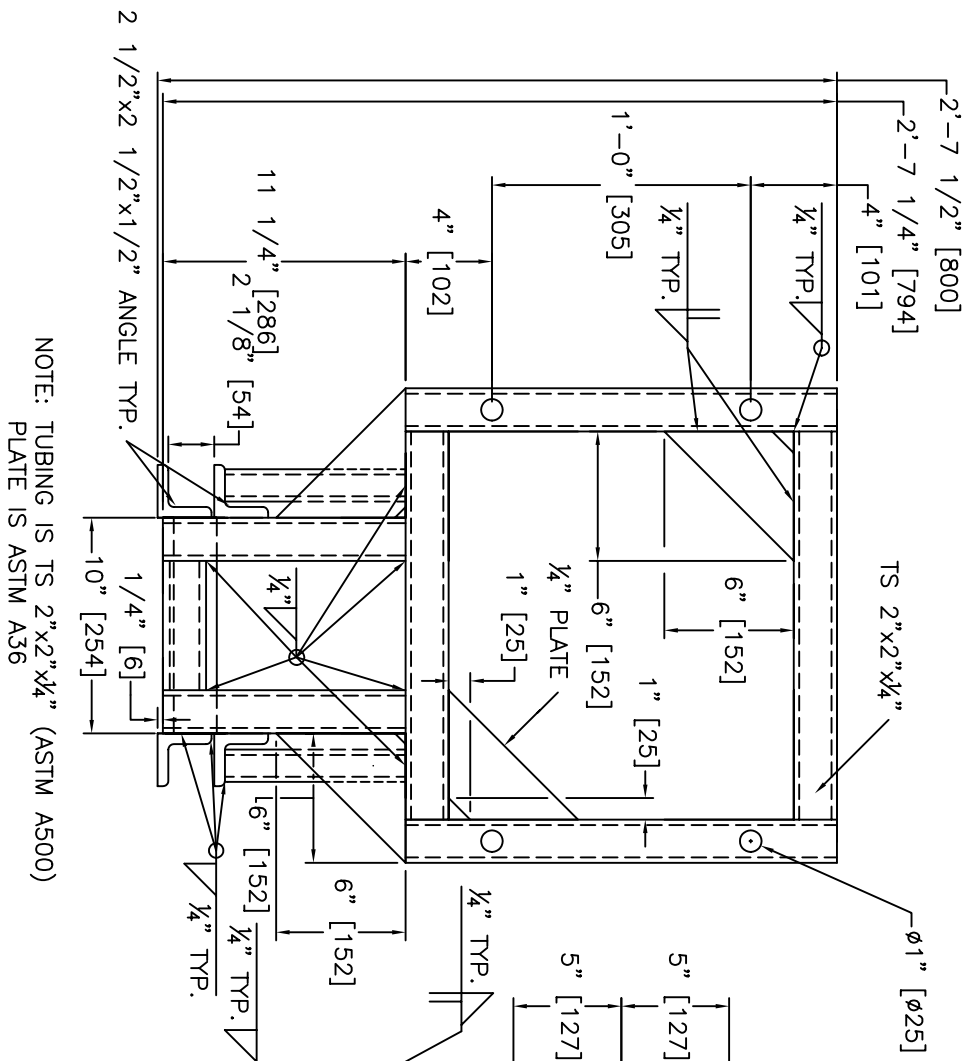
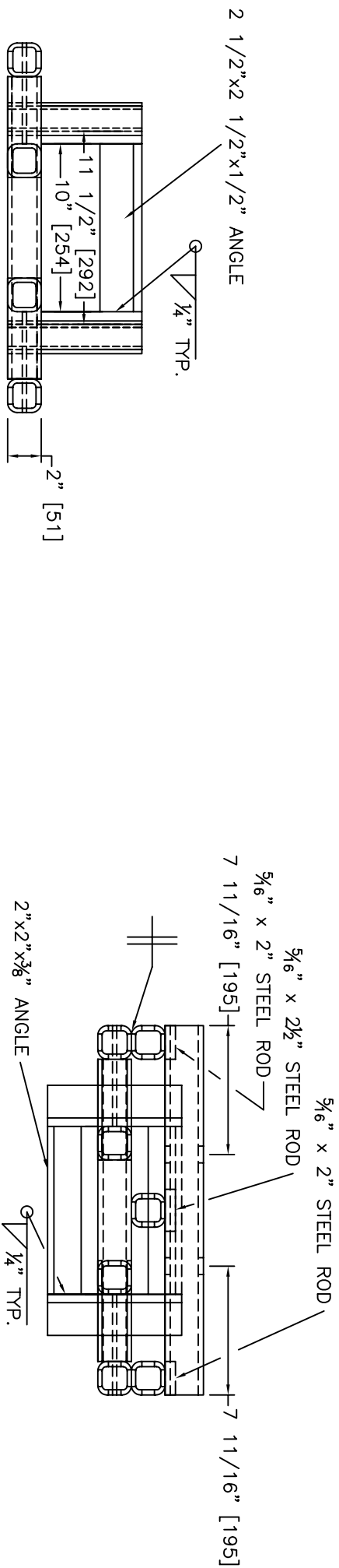

#1 DIAPHRAM

#2 DIAPHRAM

The Texas A&M University System		TEXAS TRANSPORTATION INSTITUTE		
		COLLEGE STATION, TEXAS 77843		
Revisions		Project No. 220571		
No.	Date	By	Date	Drawn By
1.	12/11/01	BAS	07/01	BAS
2.	12/12/01	BAS		
3.	12/20/01	BAS		
4.	4/3/02	CRM		
5.	11/20/04	CRM		
Title				Sheet No.
HEART CRASH CUSHION				2 of 9

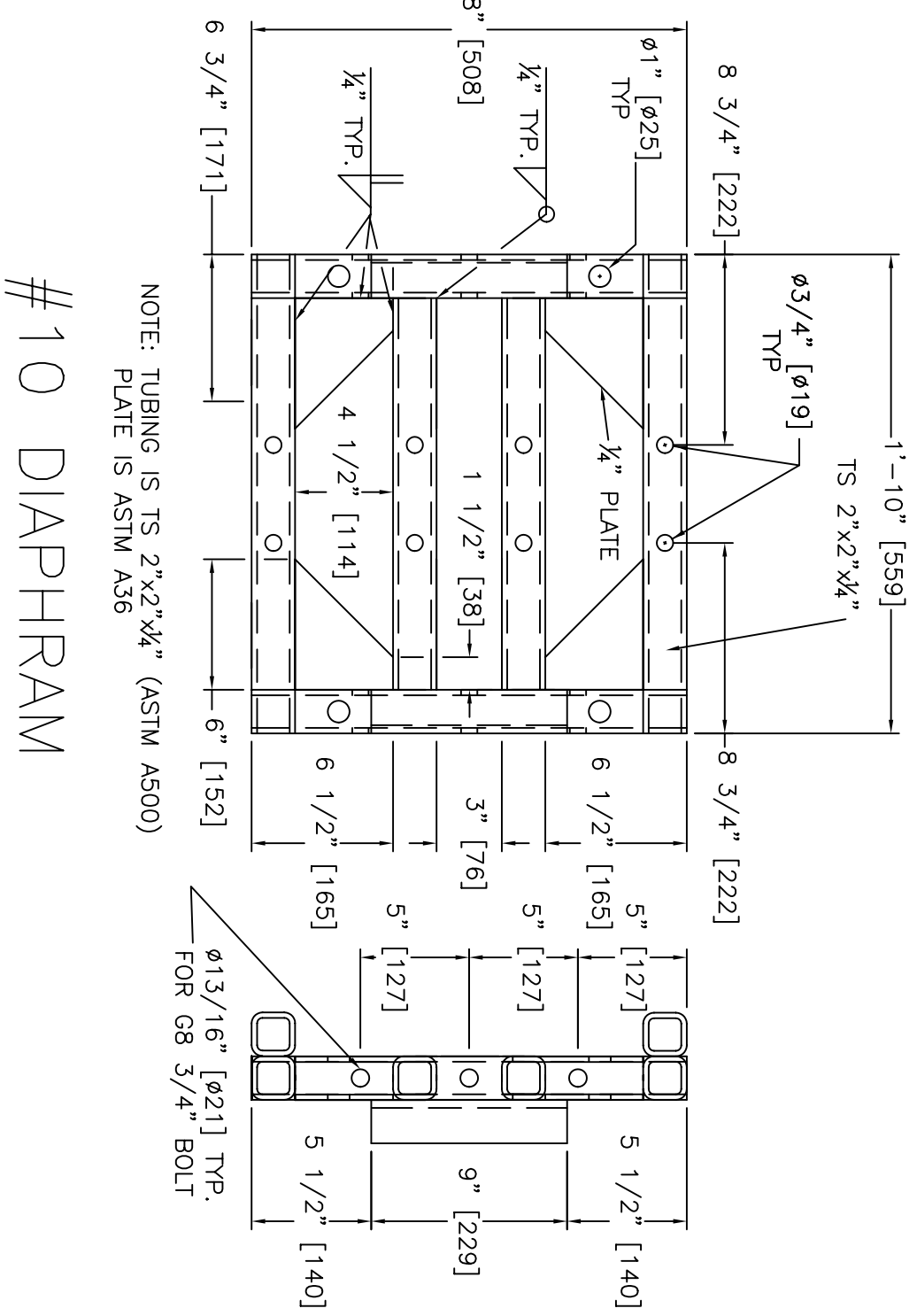
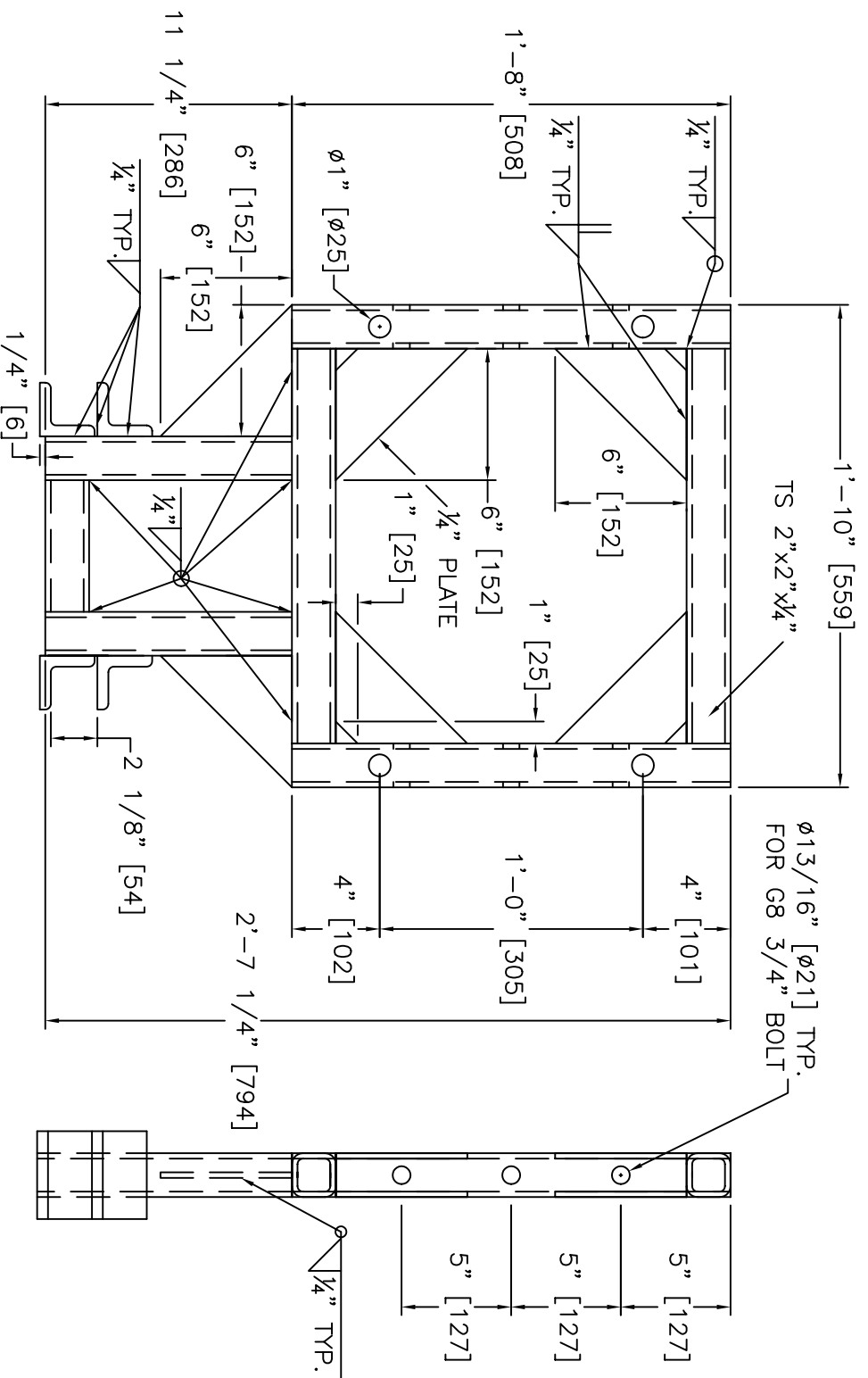
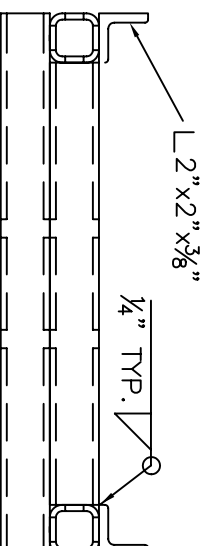
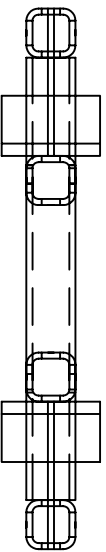

NOTE: TUBING IS TS 2"x2"x1/4" (ASTM A500)
 PLATE IS ASTM A36

#3-9 DIAPHRAMS

#10 DIAPHRAM

The Texas A&M University System

Revisions		Title	
No.	Date	By	Date
1.	12/11/01	BAS	07/01
2.	12/12/01	BAS	BAS
3.	12/20/01	BAS	BAS
4.	4/3/02	CRM	CRM
5.	11/20/04	CRM	CRM

Project No. 220571

Drawn By BAS

Scale

Sheet No. 3 of 9

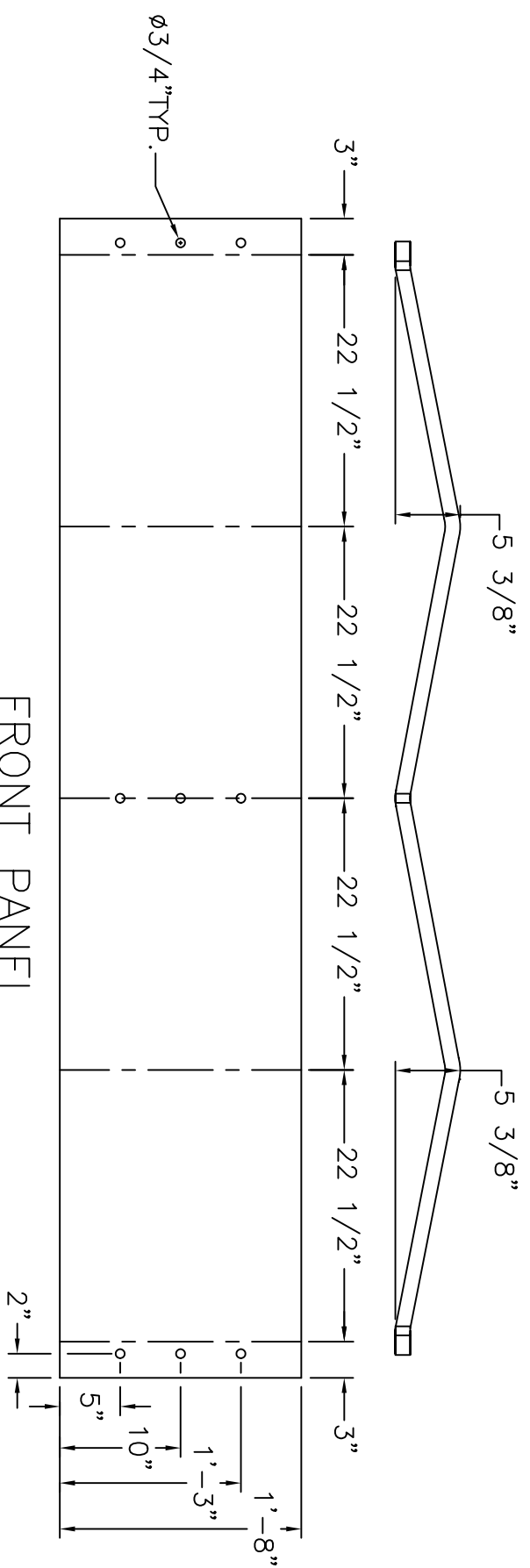

FRONT PANEL

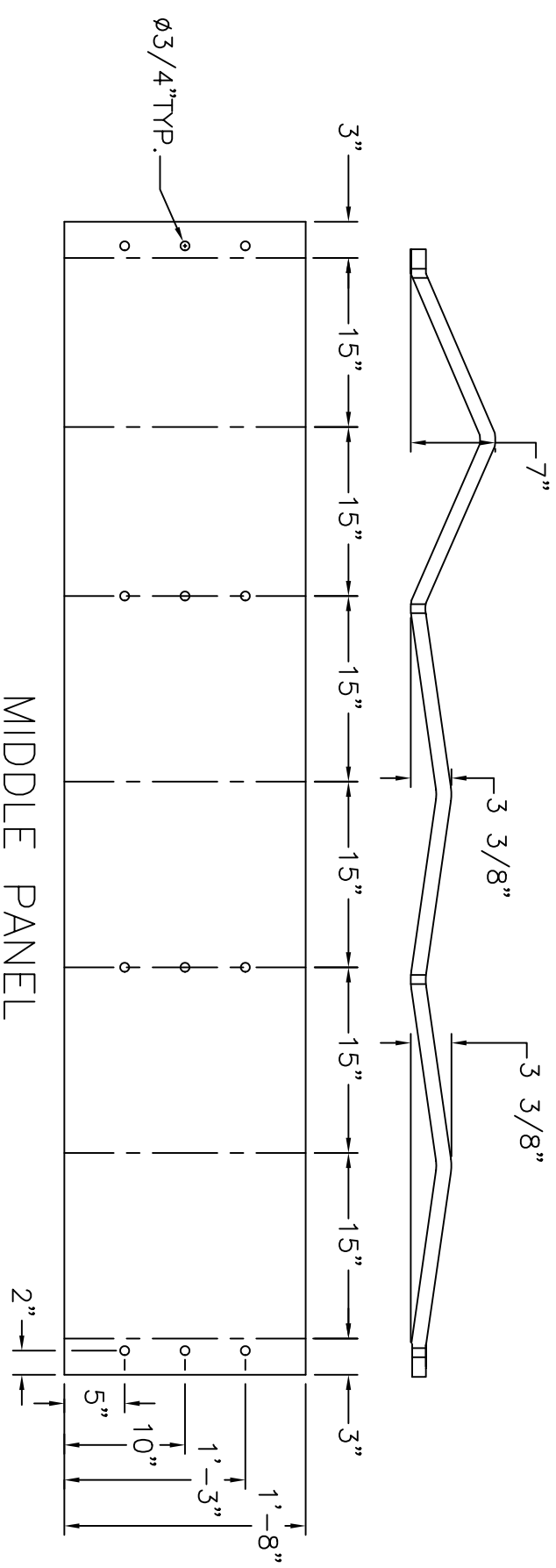

MIDDLE PANEL

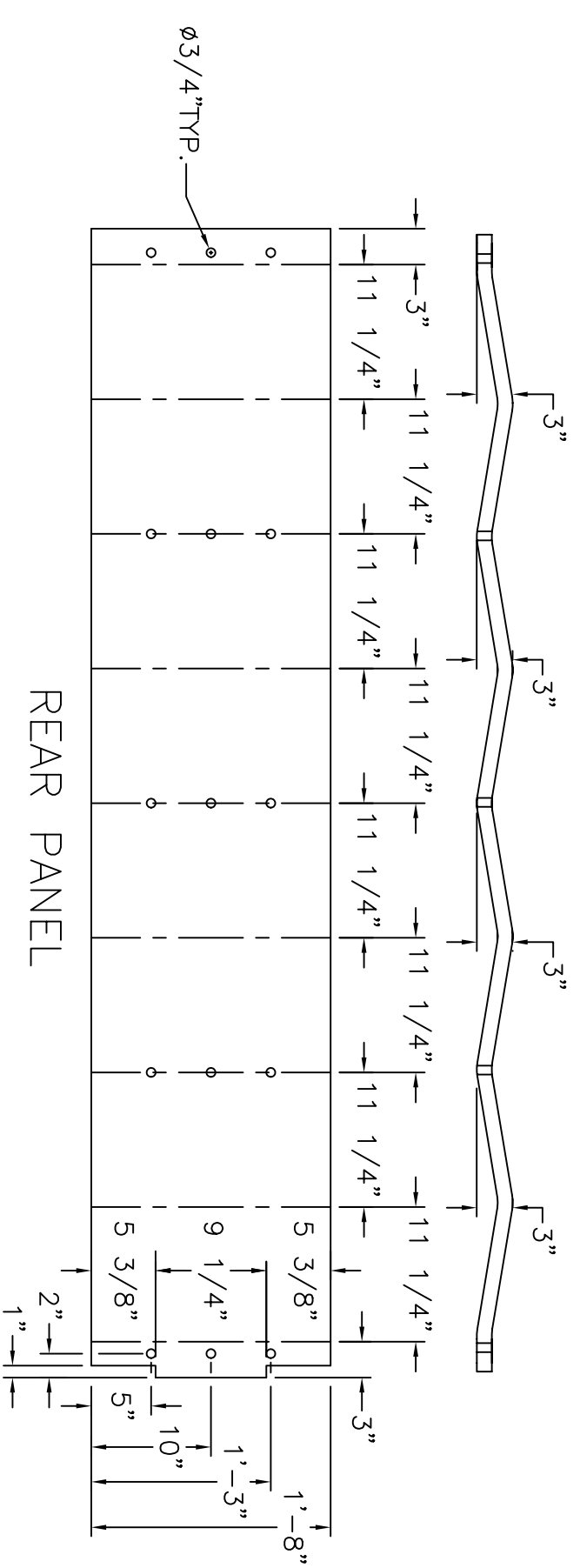

REAR PANEL

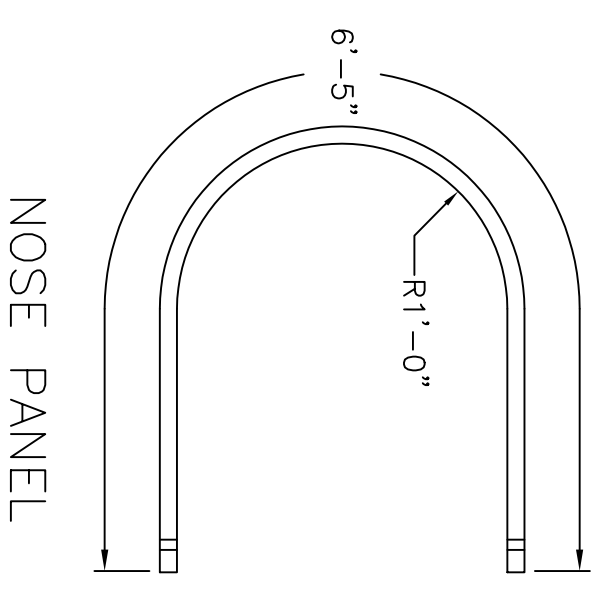
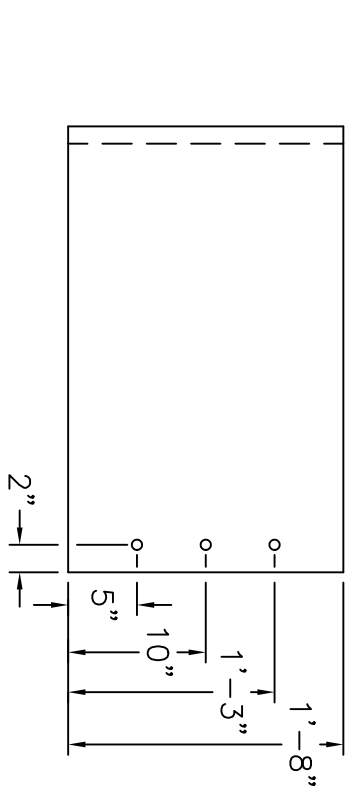

NOSE PANEL

The Texas A&M University System				
Revisions				
No.	Date	By		
1.				
2.				
3.				
4.				
5.				

TEXAS TRANSPORTATION INSTITUTE			Title	
COLLEGE STATION, TEXAS 77843			HEART CRASH CUSHION	
Project No.	Date	Drawn By	Scale	
220571	11/04	CRM		
			Sheet No.	
			9 of 9	

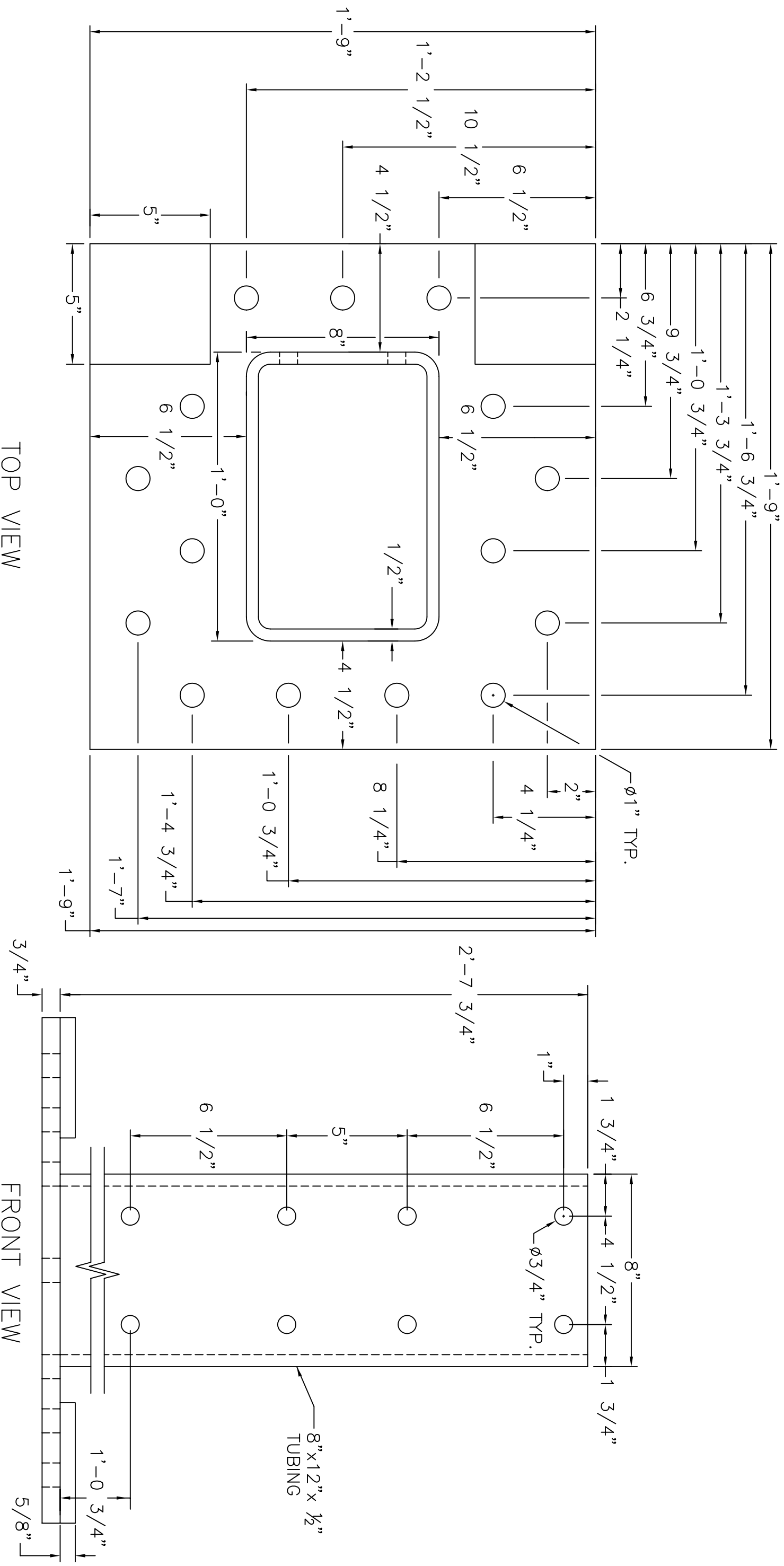

TOP VIEW

FRONT VIEW

REAR BACK UP STRUCTURE

The Texas A&M University System

Revisions			Title				
No.	Date	By	Project No.	Date	Drawn By	Scale	Sheet No.
1.	11/20/04	CRM	220571	11/04	JWK		4 of 9
2.							
3.							
4.							
5.							

TEXAS TRANSPORTATION INSTITUTE
 COLLEGE STATION, TEXAS 77843
 HEART CRASH CUSHION

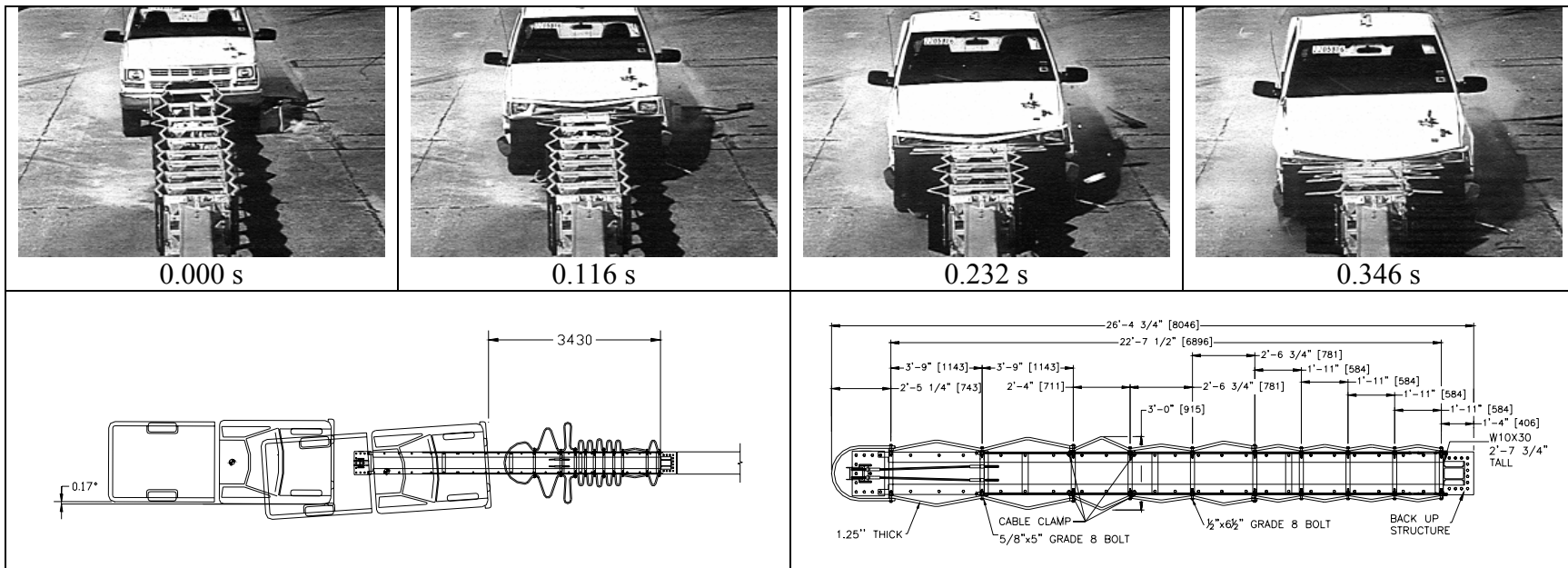

General Information

Test Agency..... Texas Transportation Institute
 Test No. 220581-6
 Date 11-25-2004

Test Article

Type..... Crash Cushion
 Name HEART
 Installation Length (m) 8.0
 Material or Key Elements High Molecular Weight/High Density Polyethylene Sheeting and Steel
 Soil Type and Condition..... Concrete Pavement, Dry

Test Vehicle

Type..... Production
 Designation..... 2000P
 Model..... 2000 Chevrolet 2500 Pickup
 Mass (kg)
 Curb..... 2156
 Test Inertial..... 2093
 Dummy N/A
 Gross Static..... 2093

Impact Conditions

Speed (km/h) 99.9
 Angle (deg) 0.2

Exit Conditions

Speed (km/h) Stopped
 Angle (deg) N/A

Occupant Risk Values

Impact Velocity (m/s)
 Longitudinal 8.2
 Lateral 0.2
 THIV (km/h) 29.4
 Ridedown Accelerations (g's)
 Longitudinal -16.8
 Lateral -5.0
 PHD (g's) 17.5
 ASI 0.98
 Max. 0.050-s Average (g's)
 Longitudinal -11.7
 Lateral 1.0
 Vertical 4.1

Test Article Deflections (m)

Dynamic 5.9
 Permanent 4.4
 Working Width 1.9

Vehicle Damage

Exterior
 VDS..... 12FD3
 CDC 12FDEW2
 Maximum Exterior
 Vehicle Crush (mm) 500
 Interior
 OCDI FS0000000
 Maximum Occupant
 Cmpt. Deformation (mm) 0

Post-Impact Behavior

(during 1.0 sec after impact)
 Max. Yaw Angel (deg)..... -7.4
 Max. Pitch Angle (deg)..... -9.5
 Max. Roll Angle (deg) -2.1

Summary of results for *NCHRP Report 350* test 3-31 on the HEART.

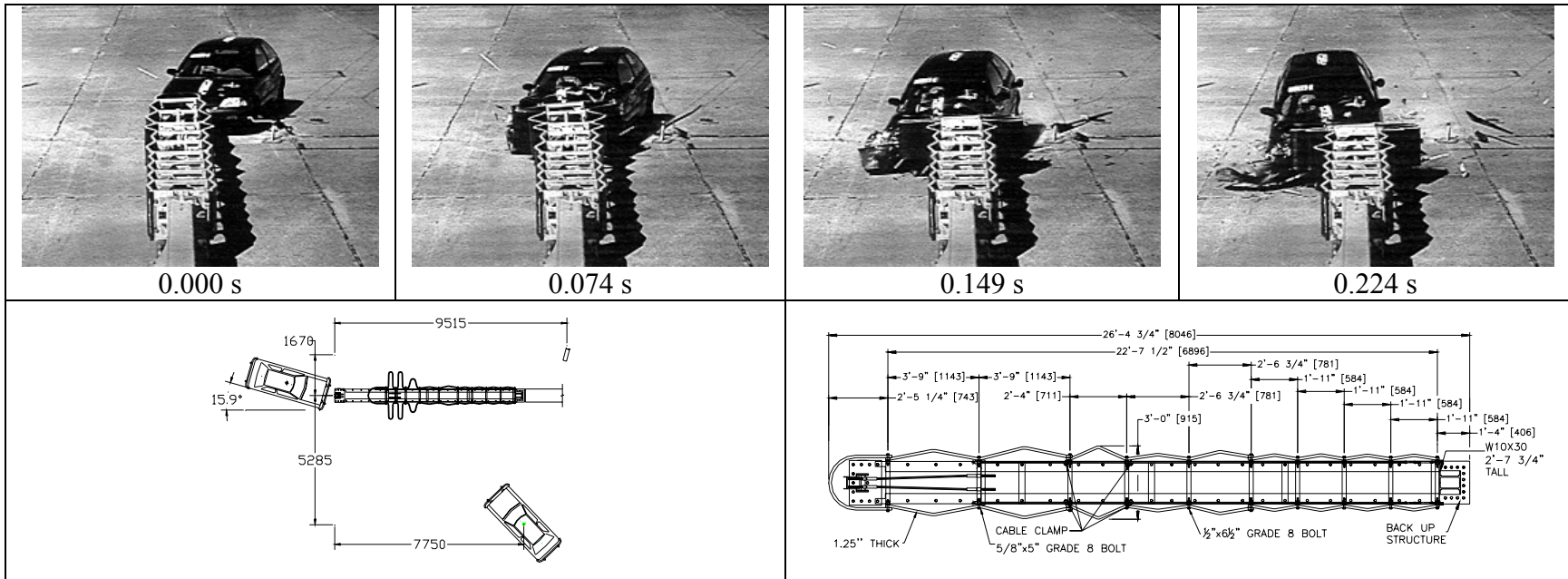

General Information

Test Agency..... Texas Transportation Institute
 Test No. 220581-5
 Date 11-21-2004

Test Article

Type..... Crash Cushion
 Name HEART
 Installation Length (m)..... 8.0
 Material or Key Elements High Molecular Weight/High Density Polyethylene Sheeting and Steel

Soil Type and Condition.....

Test Vehicle

Type..... Production
 Designation..... 820C
 Model..... 1996 Geo Metro
 Mass (kg)
 Curb..... 805
 Test Inertial..... 820
 Dummy 77
 Gross Static..... 897

Impact Conditions

Speed (km/h) 102.2
 Angle (deg) 15.9

Exit Conditions

Speed (km/h) N/A
 Angle (deg) N/A

Occupant Risk Values

Impact Velocity (m/s)
 Longitudinal 11.3
 Lateral 0.6
 THIV (km/h) 40.8
 Ridedown Accelerations (g's)
 Longitudinal -17.8
 Lateral -3.5
 PHD (g's) 17.9
 ASI 1.10
 Max. 0.050-s Average (g's)
 Longitudinal -13.0
 Lateral -2.8
 Vertical -2.8

Test Article Deflections (m)

Dynamic 3.2
 Permanent..... 1.9
 Working Width.....

Vehicle Damage

Exterior
 VDS..... 11FD6
 CDC 11FDEW3
 Maximum Exterior
 Vehicle Crush (mm) 290

Interior

OCDI FS0000000
 Maximum Occupant
 Compart. Deformation (mm) 10

Post-Impact Behavior

(during 1.0 sec after impact)
 Max. Yaw Angel (deg)..... -103.4
 Max. Pitch Angle (deg)..... -13.2
 Max. Roll Angle (deg) 14.6

Summary of results for *NCHRP Report 350* test 3-32 on the HEART.

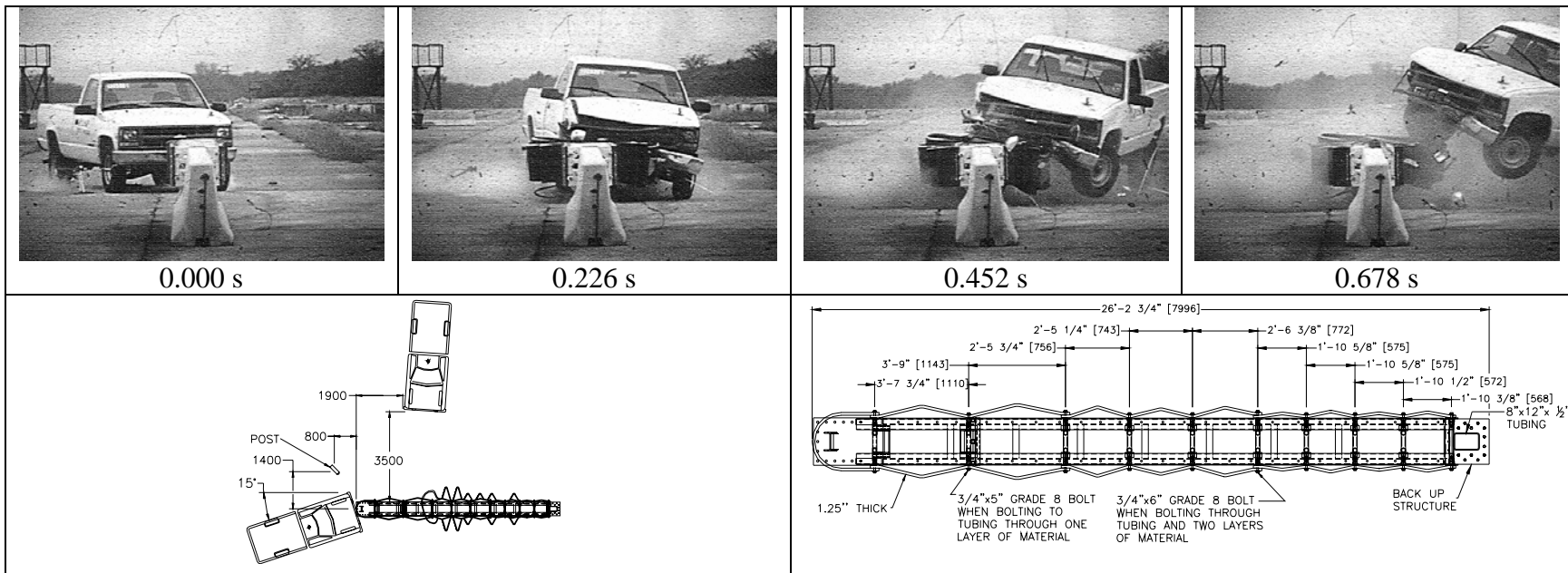

General Information

Test Agency..... Texas Transportation Institute
 Test No. 220571-1
 Date 11-19-2004

Test Article

Type..... Crash Cushion
 Name HEART
 Installation Length (m) 8.0
 Material or Key Elements HMW/HDPE Sheeting And Steel Components

Soil Type and Condition..... Concrete Apron, Dry

Test Vehicle

Type..... Production
 Designation..... 2000P
 Model..... 2000 Chevrolet C-2500
 Mass (kg)
 Curb..... 2486
 Test Inertial..... 2107
 Dummy N/A
 Gross Static..... 2107

Impact Conditions

Speed (km/h) 100.9
 Angle (deg) 15.4

Exit Conditions

Speed (km/h) 13.8
 Angle (deg) 47.6

Occupant Risk Values

Impact Velocity (m/s)
 Longitudinal 8.4
 Lateral 1.2
 THIV (km/h) 30.6
 Ridedown Accelerations (g's)
 Longitudinal -12.7
 Lateral 4.9
 PHD (g's) 12.9
 ASI 0.81
 Max. 0.050-s Average (g's)
 Longitudinal -9.6
 Lateral 3.0
 Vertical 1.7

Test Article Deflections (m)

Dynamic 5.47
 Permanent 3.65
 Working Width 8.97

Vehicle Damage

Exterior
 VDS..... 12FD2
 CDC 12FDEW2
 Max. Exterior
 Vehicle Crush (mm) 470
 Interior
 OCDI FS000000
 Max. Occupant Compartment
 Deformation (mm) None

Post-Impact Behavior

(during 1.0 sec after impact)
 Max. Yaw Angle (deg)..... 76.6
 Max. Pitch Angle (deg)..... 9.0
 Max. Roll Angle (deg) -39.7

Summary of results for *NCHRP Report 350* test 3-33 on the HEART.

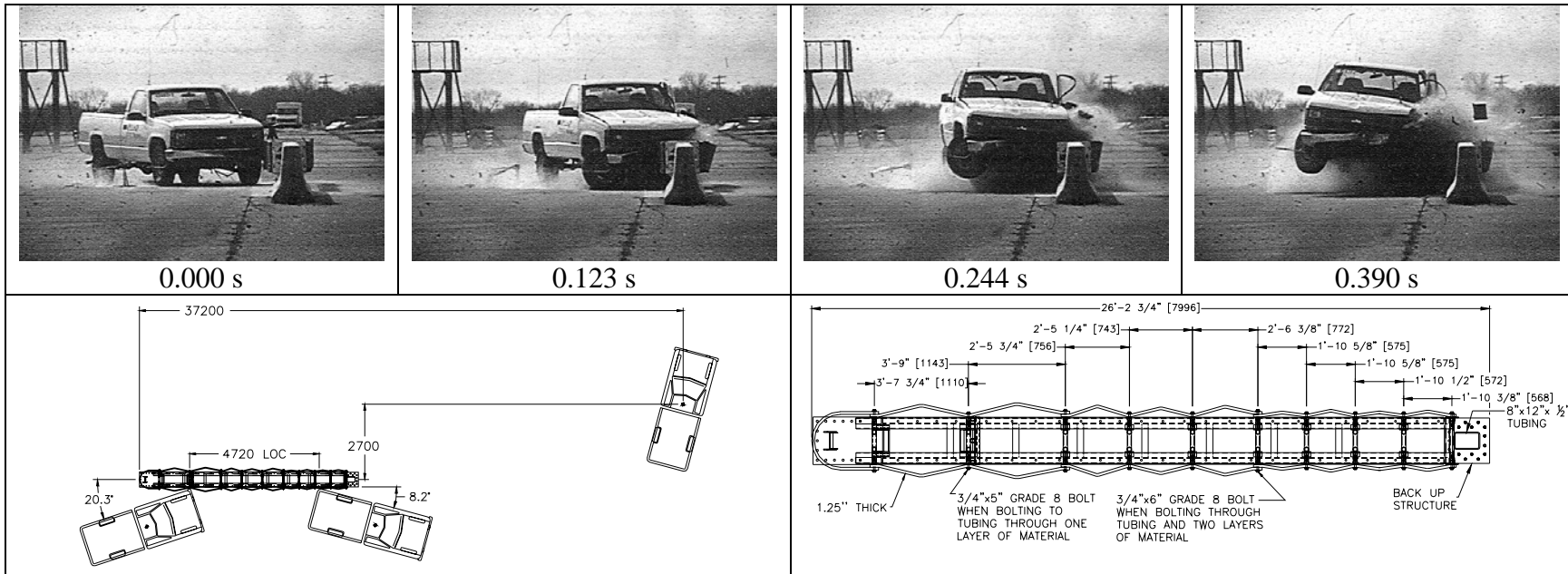

General Information

Test Agency..... Texas Transportation Institute
 Test No. 220571-2
 Date 1-26-2005

Test Article

Type..... Crash Cushion
 Name HEART
 Installation Length (m) 8.0
 Material or Key Elements HMW/HDPE Sheeting And Steel Components

Soil Type and Condition

Concrete Apron, Dry

Test Vehicle

Type..... Production
 Designation..... 2000P
 Model..... 1998 Chevrolet Cheyenne 2500
 Mass (kg)
 Curb..... 2212
 Test Inertial..... 2106
 Dummy N/A
 Gross Static..... 2106

Impact Conditions

Speed (km/h) 100.9
 Angle (deg) 20.3

Exit Conditions

Speed (km/h) 57.7
 Angle (deg) 8.2

Occupant Risk Values

Impact Velocity (m/s)
 Longitudinal 7.5
 Lateral 5.6
 THIV (km/h) 33.0
 Ridedown Accelerations (g's)
 Longitudinal -18.5
 Lateral 15.9
 PHD (g's) 22.9
 ASI 1.45
 Max. 0.050-s Average (g's)
 Longitudinal -11.9
 Lateral 9.5
 Vertical -7.8

Test Article Deflections (m)

Dynamic 0.50
 Permanent 0.10
 Working Width None

Vehicle Damage

Exterior
 VDS..... 11FL3
 CDC 11FLEW3
 Max. Exterior
 Vehicle Crush (mm) 630
 Interior
 OCDI LF1114000
 Max. Occupant Compartment
 Deformation (mm) 122

Post-Impact Behavior

(during 1.0 sec after impact)
 Max. Yaw Angle (deg) 32.0
 Max. Pitch Angle (deg) 3.8
 Max. Roll Angle (deg) -13.9

Summary of results for *NCHRP Report 350* test 3-37 on the HEART.

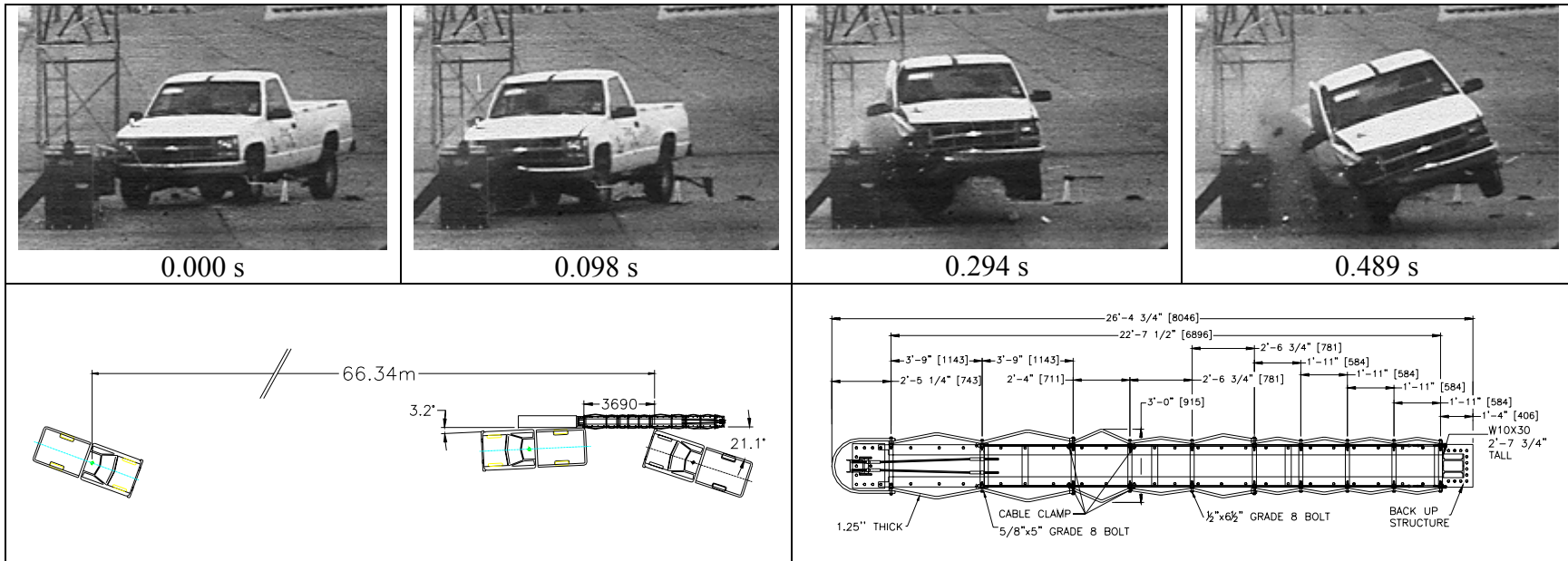

General Information

Test Agency..... Texas Transportation Institute
 Test No. 220581-1
 Date 01-23-2002

Test Article

Type..... Crash Cushion
 Name HEART
 Installation Length (m)..... 8.0
 Material or Key Elements High Molecular Weight/High Density Polyethylene Sheeting and Steel
 Soil Type and Condition Concrete Pavement, Dry

Test Vehicle

Type..... Production
 Designation..... 2000P
 Model 1995 Chevrolet 2500 Pickup
 Mass (kg)
 Curb..... 2103
 Test Inertial..... 2019
 Dummy N/A
 Gross Static..... 2019

Impact Conditions

Speed (km/h) 99.1
 Angle (deg) 21.1

Exit Conditions

Speed (km/h) 73.5
 Angle (deg) 3.2

Occupant Risk Values

Impact Velocity (m/s)
 Longitudinal 6.5
 Lateral 5.2
 THIV (km/h) 29.4
 Ridedown Accelerations (g's)
 Longitudinal -8.3
 Lateral -8.4
 PHD (g's) 10.8
 ASI 1.30
 Max. 0.050-s Average (g's)
 Longitudinal -9.1
 Lateral -9.7
 Vertical -6.0

Test Article Deflections (m)

Dynamic 0.17
 Permanent..... 0.03
 Working Width 0.92

Vehicle Damage

Exterior
 VDS..... 01RFQ5
 CDC 01FREW2
 Maximum Exterior
 Vehicle Crush (mm) 435
 Interior
 OCDI RF0102000
 Maximum Occupant
 Compart. Deformation (mm) 85

Post-Impact Behavior

(during 1.0 sec after impact)
 Max. Yaw Angle (deg)..... -28.0
 Max. Pitch Angle (deg)..... -2.7
 Max. Roll Angle (deg) 21.6

Summary of results for *NCHRP Report 350* test 3-38 on the HEART.