

December 12, 2003

Refer to: HSA-10/CC-69C

Mr. Kaddo Kothmann  
President  
Road Systems, Incorporated  
3616 Howard County Airport Road  
Big Spring, Texas 79720

Dear Mr. Kothmann:

In your October 15 letter, you provided copies of a report prepared by the Midwest Roadside Safety Facility (MwRSF) that documented a fifth test that was conducted on your Box-Beam Burster Energy Absorbing Bridge Pier Protection System, hereafter referred to as the BEAT-BP system. Information on the first four tests that you ran was submitted previously. Our review of those earlier tests resulted in changes that were incorporated into a final design and verified in the last test.

The BEAT-BP system consists of a modular (trapezoidal) box-beam frame that can be adjusted in length and width to shield median bridge piers that may vary by number, size, and/or spacing. Its approach ends use an energy-absorbing terminal with breakaway steel posts similar to your previously accepted BEAT-SSCC (refer to Federal Highway Administration ((FHWA)) acceptance letter CC69B) crash cushion. The two parallel sides of the box-beam frame are connected by angled struts and consist of single and double box beam rail elements mounted on strong steel posts set on 3-foot centers. The double rail elements are used to provide additional rail stiffness in the vicinity of the pier(s). Separate cable anchorages are also used inside the framework to limit system damage in an end-on impact. A minimum offset of eight inches from the back of the posts to a shielded bridge pier is required. These and other design details can be seen on Enclosures 1 and 2.

Because the end terminal was similar to the BEAT-SSCC except for the spacing of the breakaway steel posts, National Cooperative Highway Research Program (NCHRP) Report 350 test 3-31 was conducted to verify satisfactory crash performance. In the head-on 100km/h crash, the pickup truck was stopped in approximately 6.5 m and met occupant impact velocity and ridedown acceleration criteria. No additional tests were conducted on the terminal itself, but test 3-38 was considered necessary to verify performance when the pickup truck impacted the side of the system just in advance of the diagonal strut that connected the parallel sides of the barrier in advance of the bridge piers. The test also met all evaluation criteria. The dynamic deflection of the railing was reported to be 311 mm. The final test was NCHRP Report 350 test 3-21 which is a 25-degree impact into the side of a device at its transition to a stiffer barrier. The first two tests

on the original BEAT-BP design in which the double box-beam rail was set directly against the bridge piers were unsuccessful because of the location and extent of the resultant passenger compartment intrusion and both hood and fender contact with the simulated concrete bridge pier itself. For the last test, the design shown in the enclosures was tested. As noted above, the barrier was offset eight inches from the face of the bridge piers. As noted in the MwRSF August 12, report entitled “Performance Evaluation of the Redesigned BEAT Bridge Pier Protection System”, the occupant impact velocity of 5.84 m/sec and the ridedown acceleration of 11.77 g’s were both lower than the Report 350 preferred values of 9 m/sec and 15 g’s. The pickup truck was contained and redirected upright. However, due to the relative stiffness of the box beam rail and its narrow impact face, there was significant deformation to the passenger compartment. Maximum vertical deflections of 203 mm and 194 mm were reported near the right-middle section of the driver-side floor pan, and a 191 mm lateral deflection was noted near its left front corner. Lateral deformations exceeding 150 mm were reported at four additional locations in the driver compartment. Damage also included a large opening in the seam of the floor pan under the brake pedal. Because of the location of the deformations, the test was labeled a “marginal pass” by the researchers.

As you know, the location and degree of passenger compartment intrusion likely to cause serious injuries to vehicle occupants is a subjective decision. Lacking specific guidance, FHWA has set 150 mm of intrusion as the limiting value for most cases, but we have accepted a few individual tests where the intrusion was greater than 150 mm. The NCHRP Report 350 states that the degree of acceptable intrusion is a factor “that must be assessed...by the judgment of the test agency and the user agency, or both.” Since the researchers considered the intrusion seen in test 3-21 to be acceptable, I will agree with their conclusion that the BEAT BP system is marginally acceptable and may be used as a test level 3 device on the National Highway System (NHS), provided that it is selected with full user awareness of its observed performance characteristics.

Please note the following standard provisions that apply to this specific letter of acceptance:

- Any design changes that may adversely influence the crashworthiness of the BEAT-BP will require FHWA reassessment and concurrence.
- Should FHWA discover that the qualification testing was flawed, that in-service performance reveals unacceptable safety problems, or that the device being marketed is significantly different from the version that was crash tested, it reserves the right to modify or revoke its acceptance.
- You will be expected to supply potential users with sufficient information on design and installation requirements to ensure optimal performance. This information should include, but is not limited to, the need for a minimum eight-inch offset from a shielded pier or support and the necessity that the BEAT BP system be installed on a slope no steeper than 10:1 (as per note 7 on Enclosure 1).
- You will be expected to certify to potential users that the hardware furnished has essentially the same chemistry, mechanical properties, and geometry as that submitted for acceptance, or that

a custom-designed layout will meet the crashworthiness requirements of NCHRP Report 350.

- To prevent misunderstanding by others, this letter of acceptance, designated as number CC-69C, shall not be reproduced except in full. This letter, and the test documentation upon which this letter is based, is public information. All such letters and documentation may be reviewed at our office upon request.
- The BEAT BP includes patented components and is considered proprietary. If a proprietary device is *specified by a highway agency* for use on Federal-aid projects, except exempt, non-NHS projects, it: (a) must be supplied through competitive bidding with equally suitable unpatented items; (b) the highway agency must certify that they are essential for synchronization with existing highway facilities or that no equally suitable alternative exists or; (c) they must be used for research or for a distinctive type of construction on relatively short sections of road for experimental purposes. Our regulations concerning proprietary products are contained in Title 23, Code of Federal Regulations, Section 635.411.

Sincerely yours,

***/Original Signed By/***

John R. Baxter, P.E.  
Director, Office of Safety Design  
Office of Safety

2 Enclosures

# PLAN

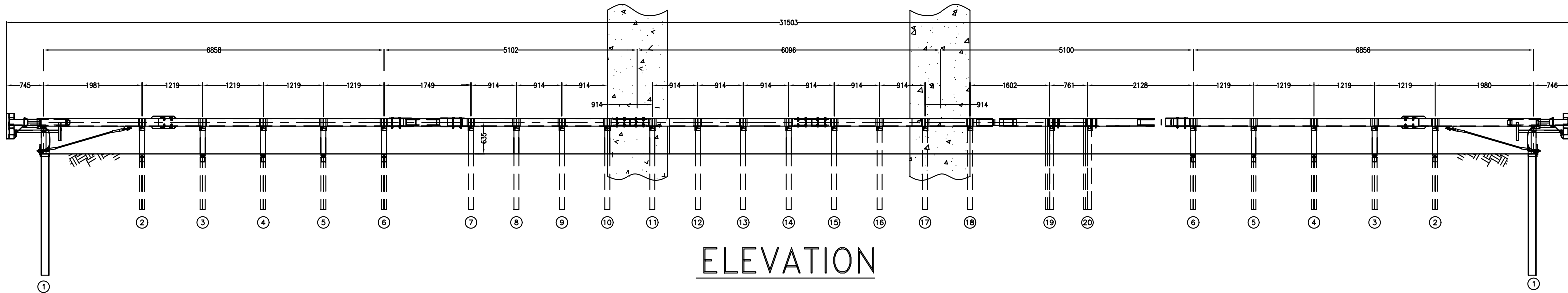
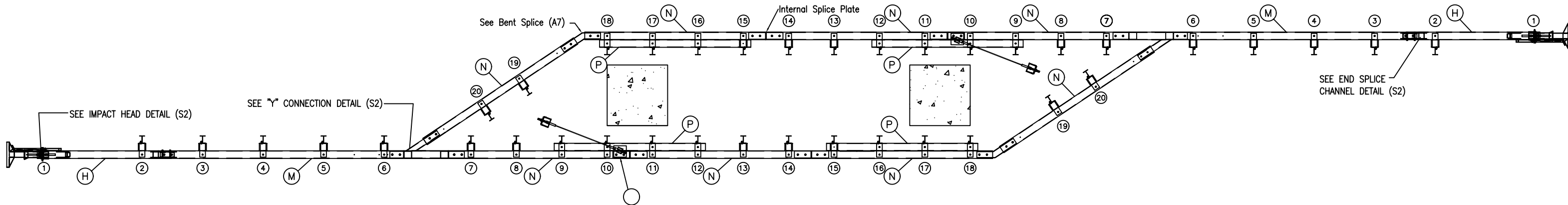

TYPICAL SINGLE PIER APPLICATION

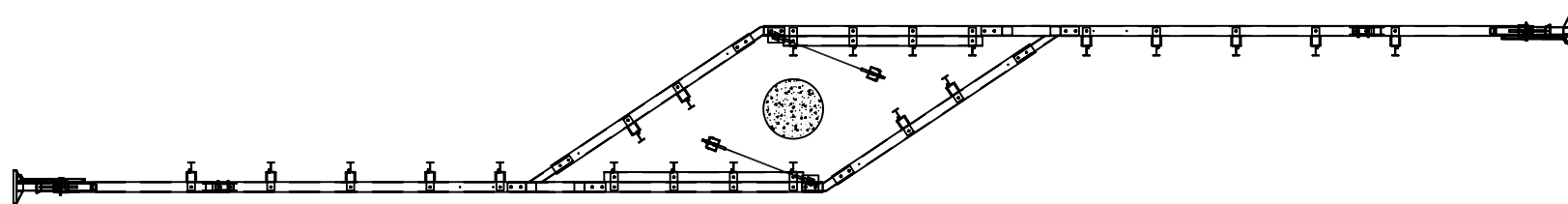

TYPICAL CYLINDRICAL PIER APPLICATION

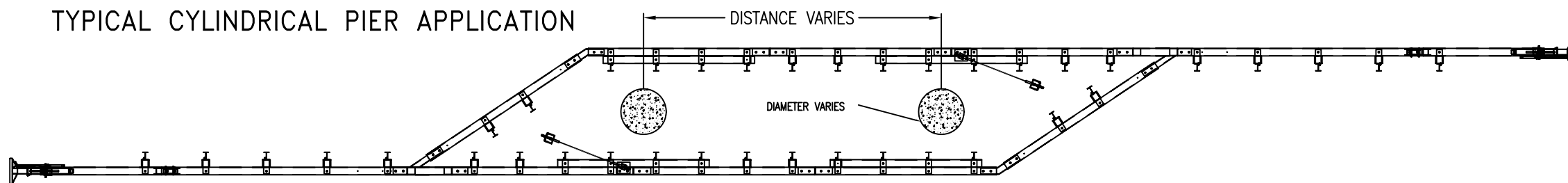

TYPICAL MULTIPLE PIER APPLICATION

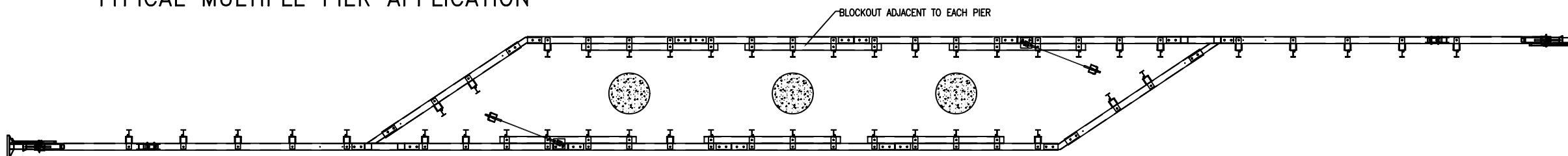

General Notes for the BEAT-BP:

- 1.) Unless otherwise noted, all hardware, cable assemblies, tubing, posts, impact heads and other steel components shall be galvanized.
- 2.) When site conditions permit, posts may be driven. If posts are placed in a drilled hole, the backfill material must be satisfactorily compacted to prevent settlement.
- 3.) Contact the manufacturer for installation recommendations when rock is encountered.
- 4.) The lower section of post #1 should not be driven with the upper post section attached.
- 5.) The breakaway cable assembly must be taut. A locking device (vice grips or channel locks) should be used to prevent the cable from twisting when tightening nuts.
- 6.) An object marker meeting State specifications should be installed on the front of the impact head.
- 7.) The approach area in front of the BEAT-BP and the area within the system itself shall be free of fixed obstacles and have a fill slope or a cut slope of 10:1 or flatter.



BEAT BRIDGE PIER PROTECTION SYSTEM

SYSTEM LAYOUT FOR 1219MM PIERS AT 6096MM SPACING AND TYPICAL APPLICATIONS

Drawing Name: BEAT-BP

Scale: NONE

Sheet: S1  
Date: 6/6/03  
By: JRR  
Rev:

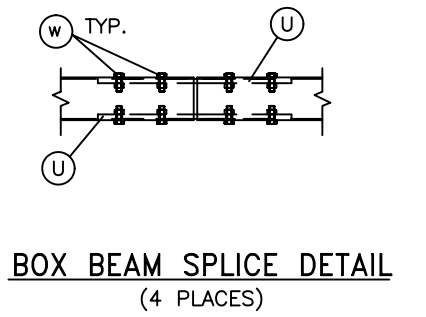
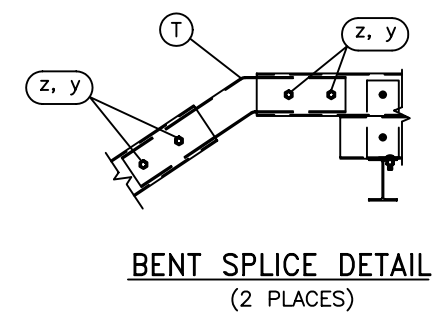
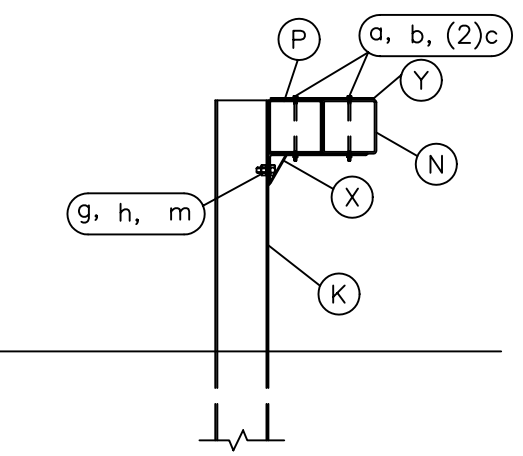
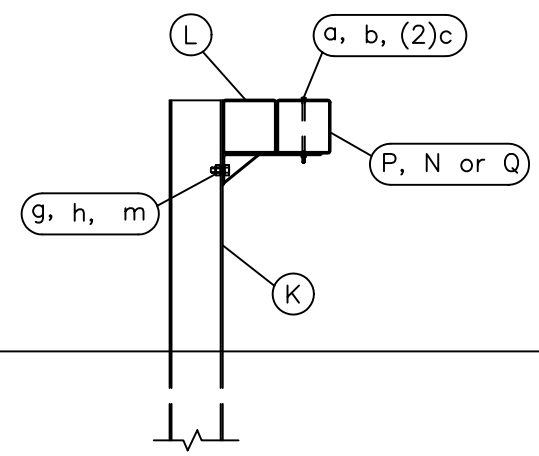
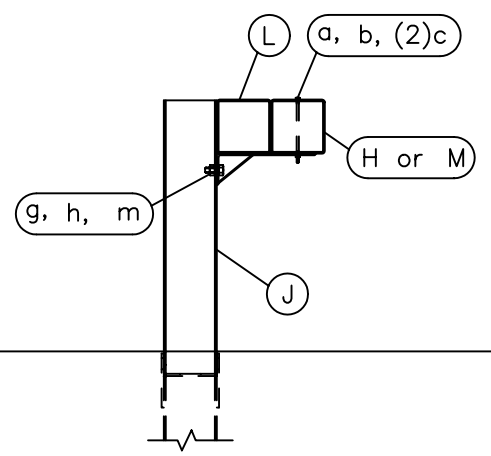
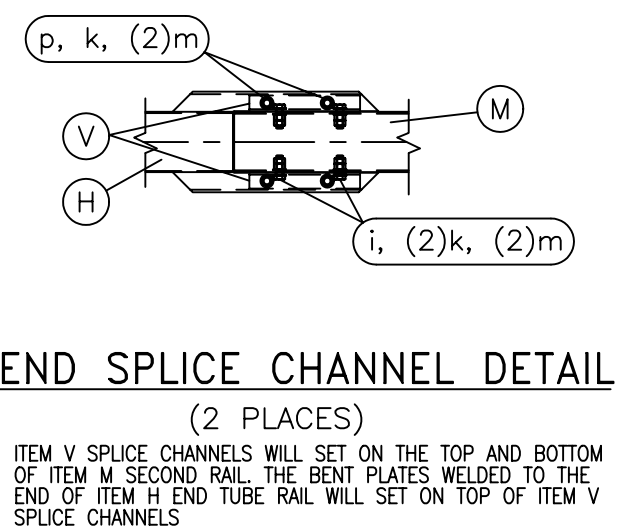
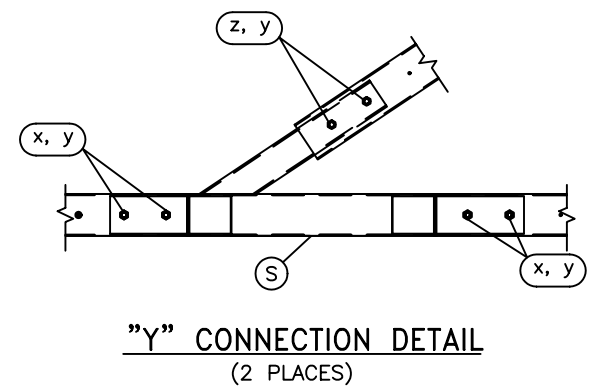
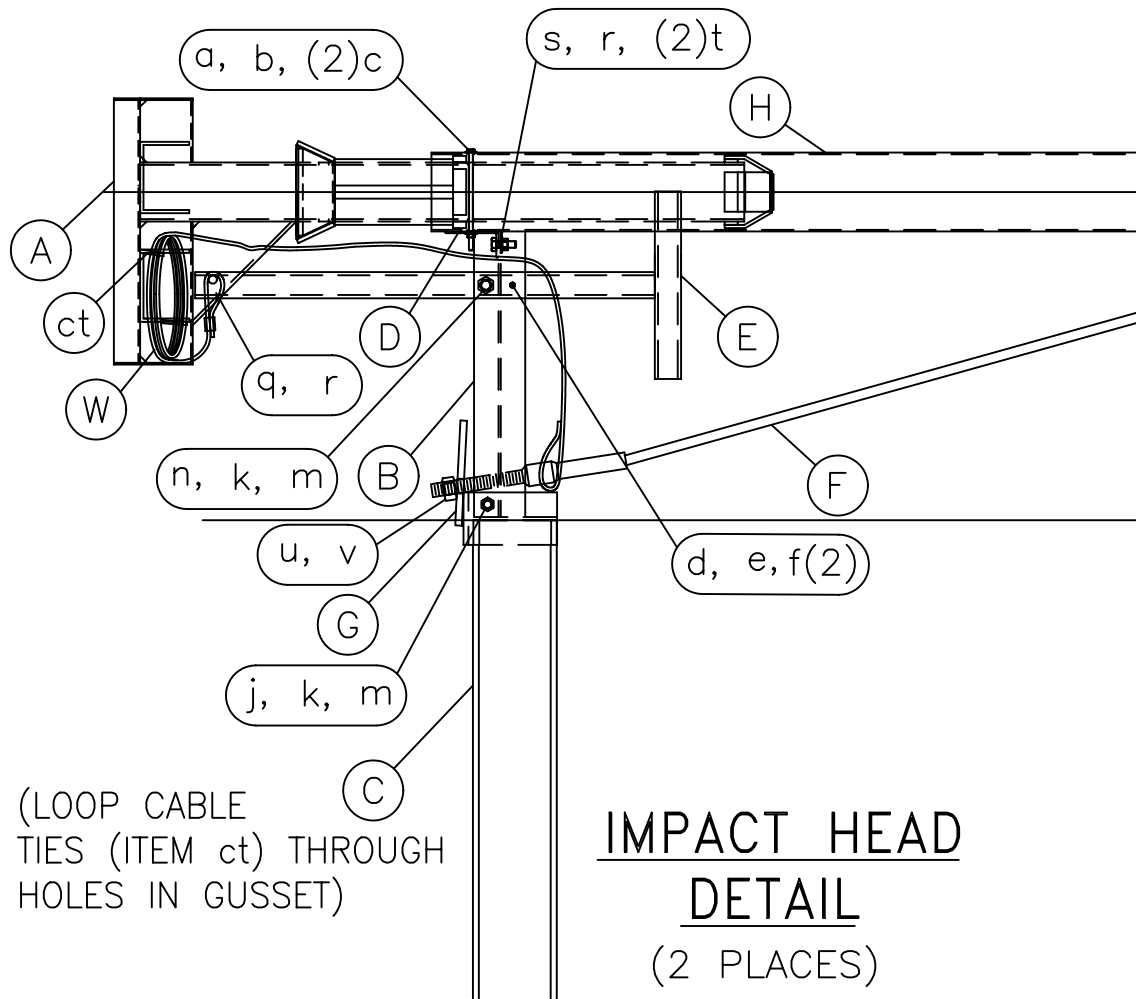

ITEM	QTY	DESCRIPTION
A	2	Box-Beam Impact Head
B	2	Upper End Post (A1) W152x13.4 x 546m LG.
C	2	Lower End Post (A4) W152x22.3 x 2438mm LG.
D	2	Support Bracket (B1) L102x51 x 102mm LG.
E	2	Post Breaker (A2) Welded TS51x51x6mm
F	2	Cable Anchor Assembly
G	2	Cable Anchor Bearing Plate
H	2	End Tube Rail (A5) x 2438mm LG. 3mm thick
J	10	Steel Breakaway Post W152x13.4 x 1829mm LG.
K	28	Standard Steel Post W152x13.4 x 1829mm LG.
L	22	Support Bracket (A9) TS152x152 w/ Bent PL.
M	2	Second Rail (B11) x 4940mm LG.
N	8	BP-Rail Section (A11) 3654 mm LG.
P	4	BP-Extended Block (B8) 3048 mm LG.
Q	2	Angled Tube Rail (A8) 2731 mm LG.
R	2	Support Rail (B10) 1473 mm LG.
S	2	"Y" Connection (A6)
T	2	Bent Splice (A7)
U	8	Box Beam Splice Plates w/Nuts (2 per splice)
V	4	End Section Splice (A3) Bent PL.
W	2	10 GALV. Cable x 6096mm
X	16	Support Bracket (A10)
Y	16	Tie Bracket 3/16" (A36)
Z	2	Anchor Plate (A36)
HARDWARE		
a	56	8 x 191mm Hex Bolt Grade 5
b	56	8mm Hex Nut
c	112	8mm Washer
d	2	6 x 76mm Hex Bolt
e	2	6mm Hex Nut
f	4	6mm Washer
g	38	16 x 38mm Guardrail Bolt
h	38	16mm Recess Nut
i	8	16 x 64mm Hex Bolt Grade 5
j	2	16 x 203mm Hex Bolt Grade 5
k	28	16mm Hex Nut
m	74	16mm Washer
n	2	16 x 76mm Hex Bolt Grade 5
p	8	16 x 152mm Hex Bolt Grade 5
q	2	13 x 127mm Hex Bolt Grade 5
r	4	13mm Hex Nut
s	2	13 x 51mm Hex Bolt
t	4	13mm Washer
u	8	25mm Hex Nut Grade 5
v	8	25mm Washer Grade 5
w	32	19 x 51mm Hex Bolt Grade 5
x	8	19 x 203mm Hex Bolt Grade 5
y	20	19mm Hex Nut
z	12	19 x 178mm Hex Bolt Grade 5
ct	4	Cable Tie



Big Spring, TX  
Phone: 915-263-2435  
or Phone: 330-346-0721

**BEAT BRIDGE PIER PROTECTION SYSTEM**

SYSTEM DETAILS AND PARTS LIST

Drawing Name: BEAT-BP      Scale: NONE

Sheet: **S2**

Date: 6/6/03

By: JRR      Rev: 