



U.S. Department
of Transportation

**Federal Highway
Administration**

NOV 27 1992

400 Seventh St., S.W.
Washington, D.C. 20590

Refer to: HNG-14

NOV 27 1992

J. M. Essex, P.E.
Vice President, Sales
Energy Absorption Systems, Inc.
One East Wacker Drive
Chicago, Illinois 60601

Dear Mr. Essex:

This is in response to your November 5 letter requesting that the Federal Highway Administration (FHWA) issue a letter of acceptance for your company's "Triton" water filled barrier. On that date you met with representatives from the FHWA's Office of Research, Office of Engineering, and Office of Safety and Technology Applications to introduce the barrier and show crash test films. You also provided a November 1992 report of the crash testing you conducted and attested to by William H. Kimball, an independent professional engineer.

The Triton barrier consists of 1981-mm long by 813-mm high by 533-mm wide (78-inch by 32.25-inch by 21.5-inch) segments of lightweight polyethylene plastic shells designed to accept water ballast. The plastic barrier shell is supplemented by an internal steel framework to provide additional rigidity during handling and impacts. There is also a cable along the top connecting the joints between barrier segments. This cable provides the barrier's tensile capacity during impacts. The barrier is molded in a shape that interacts with an impacting vehicle to reduce its roll, pitch, and yaw.

The tests were conducted to assess the compliance of the Triton barrier to test level 2 of the National Cooperative Highway Research Program (NCHRP) Report 350, "Recommended Procedures for the Safety Evaluation of Highway Features." Although the NCHRP 350 is not yet published, we accept its use as the guideline for crash testing because of the nature of the device in question. The current guide, NCHRP 230, does not provide test conditions for devices only for temporary use in low speed work zones. Test level 2 of NCHRP 350 is a matrix of tests using a small passenger car and a pickup truck at impact speeds of 70 km/h (43.5 mph). The results of the test level 2 test covered in the report you provided are summarized below:

Test Number	147-043	147-044
Vehicle Mass, kg (wt., lbs.)	1970.5 (4345)	807.3 (1780)
Impact Speed, km/h (mph)	72.3 (44.9)	72.0 (44.7)
Angle, Degrees	25	20

Occupant Risk Values

Impact Velocity, m/s (fps)		
x-direction (longitudinal)	5.8 (19.0)	6.6 (21.7)
y-direction (lateral)	1.9 (6.2)	3.2 (10.5)
Ridedown Acceleration, g's		
x-direction	-3.7	-6.6
y-direction	-2.8	-4.1
Test Article Deflection, m (ft)	3.9 (12.8)	1.0 (3.3)

In both tests, the vehicle came to rest against the barrier so there was no exit angle or speed.

These results meet the change in velocity, occupant risk, and redirection guidelines of NCHRP 350. As these guidelines contain the current consensus advice on testing and evaluating highway features and because they are likely to be formally recognized by the FHWA, the Triton water filled barrier described above is acceptable for use on Federal-aid highway projects, within the range of conditions tested, if proposed by a State.

It is very important to note the speed range limitations and deflection requirements of this barrier. We appreciate that you have been very explicit in proposing uses for this barrier at speeds of approximately 70 km/h or less. We wish to reiterate that this barrier should only be used where operating speed is not expected to significantly exceed the tested 72.3 km/h (45 mph). For example, the Triton barrier may not be appropriate for temporary traffic control zones on highways normally posted at 55 mph but having a temporary posted speed of 45 mph. In most locations of this type, the operating speed would remain at or above 55 mph, obviously exceeding the design speed of the Triton barrier. With regard to deflection, it will be essential that the deflection requirements of the barrier be considered in determining its applicability to a specific site.

Presumably, you will supply potential users with sufficient information on structural design and installation requirements to ensure proper performance. We anticipate that the States will require certification from Energy Absorption Inc., that the Triton barrier segments furnished will have essentially the same composition, mechanical properties, and geometry as those used in the tested barrier.

Usually the choice of work zone traffic control devices is the prerogative of the contractor, within limits established by the State. However, the Triton water filled barrier is proprietary. Thus, if specified by a State for use on a Federal-aid highway project, (a) it must be supplied through competitive bidding with equally suitable unpatented items; (b) the State highway agency must certify that it is essential for synchronization with existing highway

facilities or that no equally suitable alternative exists; or (c) it must be used for research or for a distinctive type of construction on relatively short sections of road for experimental purposes. Our regulations concerning proprietary products are contained in Title 23, Code of Federal Regulations, Section 635.411, a copy of which is enclosed.

By copy of this letter we are informing the FHWA field offices of this action.

Sincerely yours,

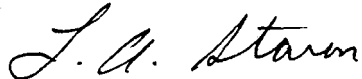
A handwritten signature in cursive script that reads "L. A. Staron".

Lawrence A. Staron
Chief, Federal-Aid and Design Division

Enclosure

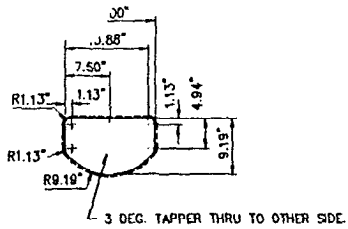

DETAIL B
FORKLIFT PORT

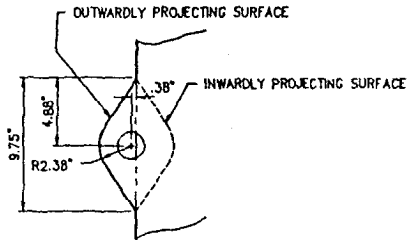

DETAIL E
END CONNECTION - TYP. BOTH ENDS OF BARRIER
(SOME DETAIL REMOVED FOR CLARITY)

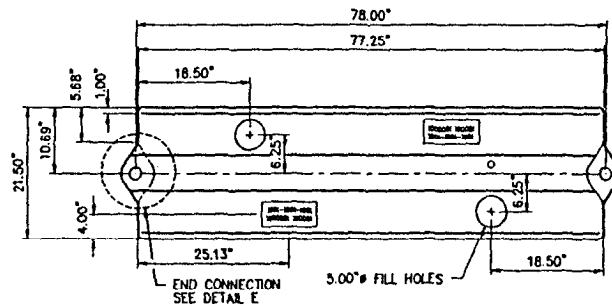

TOP VIEW

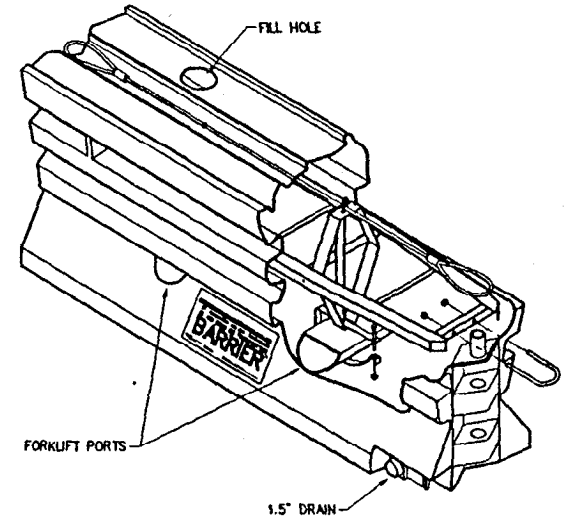

ISOMETRIC VIEW

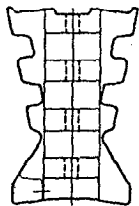

LEFT END VIEW

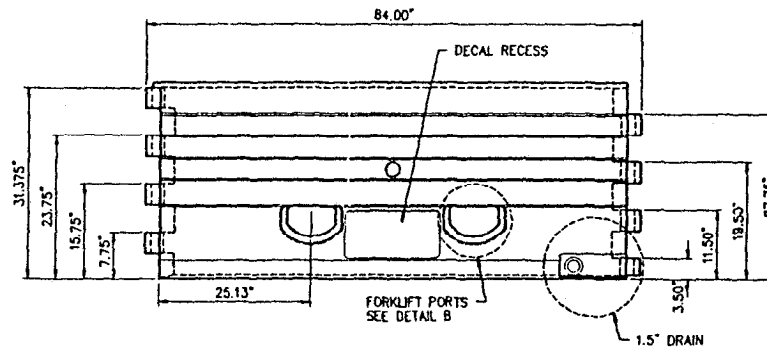

SIDE VIEW

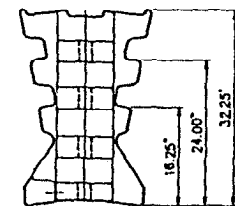

RIGHT END VIEW

Q	X
W	X
PD	
C	X
P	X
S	

- NOTE:
- 1 RADIUS ALL CORNERS, 0.75" R, EXCEPT WHERE NOTED.
 - 2 DIMENSIONS SHOWN ARE APPROXIMATIONS AND MAY VARY DUE TO SHRINKAGE AFTER MOLDING.

Revisions	Date	Rev.	By	Ckd.	App.	DESIGN SPEED	M.P.H.
						AVERAGE G's	
						EST. FORCE ON BACKUP	
						STRUCTURE	KIPS
						Designed	Date
						Drawn <i>D L Staus</i>	11/13/92
						Checked <i>X. Markson</i>	11/13/92
						Approved <i>J.F. LaTurner</i>	11/13/92

REFERENCES	
Project No. _____	Sales Order No. _____
Serial No. _____	Color _____

ENERGY ABSORPTION SYSTEMS, INC. ENGINEERING AND RESEARCH DEPARTMENT			
TRITON BARRIER MOLDED PART			
SCALE (1/16) 3/4" = 1'-0"	SIZE C	DWG NUMBER 27-95-04R	REV REV