



BAY AREA
AIR QUALITY
MANAGEMENT
DISTRICT

BOARD OF DIRECTORS' REGULAR MEETING

December 5, 2007

A meeting of the Bay Area Air Quality Management District Board of Directors will be held at 9:45 a.m. in the 7th floor Board Room at the Air District headquarters, 939 Ellis Street, San Francisco, California.

Questions About an Agenda Item

The name, telephone number and e-mail of the appropriate staff person to contact for additional information or to resolve concerns is listed for each agenda item.

Meeting Procedures

The public meeting of the Air District Board of Directors begins at 9:45 a.m. The Board of Directors generally will consider items in the order listed on the agenda. However, any item may be considered in any order.

After action on any agenda item not requiring a public hearing, the Board may reconsider or amend the item at any time during the meeting.

BOARD OF DIRECTORS' REGULAR MEETING A G E N D A

WEDNESDAY
DECEMBER 5, 2007
9:45 A.M.

BOARD ROOM
7TH FLOOR

CALL TO ORDER

Opening Comments
Roll Call
Pledge of Allegiance

Chairperson, Mark Ross
Clerk of the Boards

PUBLIC COMMENT PERIOD

Public Comment on Non-Agenda Items, Pursuant to Government Code Section 54954.3
Members of the public are afforded the opportunity to speak on any agenda item. All agendas for regular meetings are posted at District headquarters, 939 Ellis Street, San Francisco, CA, at least 72 hours in advance of a regular meeting. At the beginning of the regular meeting agenda, an opportunity is also provided for the public to speak on any subject within the Board's subject matter jurisdiction. Speakers will be limited to three (3) minutes each.

PROCLAMATION/COMMENDATION

The Board of Directors will recognize Mary Romaidis, Clerk of the Board for her 22 years of dedicated service to the Air District upon her retirement.

CONSENT CALENDAR (ITEMS 1 – 5)

Staff/Phone (415) 749-

1. Minutes of November 7, 2007

M. Romaidis/4965
mromaidis@baaqmd.gov

2. Communications
Information only.

J. Broadbent/5052
jbroadbent@baaqmd.gov

3. Quarterly Report of Division Activities

J. Broadbent/5052
jbroadbent@baaqmd.gov

Report of Division Activities for the months of July – September 2007.

4. Consider Adoption of Resolution Endorsing Local Air District's Role in AB 32 Implementation of Mandatory Reporting of Greenhouse Gases

J. Broadbent/5052
jbroadbent@baaqmd.gov

The Board of Directors will consider adoption of a resolution endorsing a role for local Air Districts role in implementation of mandatory reporting of greenhouse gases through action being taken by the California Air Resources Board.

5. Consider Adoption of Resolution Endorsing Changes to the California Air Resources Board's (ARB) Regulations to Reduce Emissions from Diesel Auxiliary Engines on Ocean-Going Vessels while at Berth at a California Port
J. Broadbent/5052
jbroadbent@baaqmd.gov

The Board of Directors will consider adoption of a resolution endorsing changes to ARB's proposed regulation requiring ocean-going vessels to reduce their emissions while at berth at a California port.

COMMITTEE REPORTS AND RECOMMENDATIONS

6. Report of the **Personnel Committee** Meeting of November 14, 2007

CHAIR: H. BROWN

J. Broadbent/5052
jbroadbent@baaqmd.gov

Action (s): The Committee recommends Board of Directors' approval of the following:

- A) Appointment of (9) Advisory Council members effective January 1, 2008 ending December 31, 2009; and*
- B) Appointment of (2) Advisory Council members to a one-year term of office effective January 1, 2007 and ending December 31, 2008 due to 12-year term limit on the Advisory Council.*

7. Report of the **Climate Protection Committee** Meeting of November 15, 2007

CHAIR: P. TORLIATT

J. Broadbent/5052
jbroadbent@baaqmd.gov

8. Report of the **Executive Committee** Meeting of November 19, 2007

CHAIR: M. ROSS

J. Broadbent/5052
jbroadbent@baaqmd.gov

Action(s): The Committee recommends Board of Directors' approval to initiate joint legislation with the Metropolitan Transportation Commission regarding a regional fee on gasoline.

9. Report of the **Legislative Committee** Meeting of November 26, 2007

CHAIR: B. WAGENKNECHT

J. Broadbent/5052
jbroadbent@baaqmd.gov

Action (s): The Committee may recommend Board of Directors' approval of a 2008 legislative agenda.

10. Report of the **Public Outreach Committee** Meeting of November 26, 2007

CHAIR: C. KLATT

J. Broadbent/5052
jbroadbent@baaqmd.gov

11. Report of the **Stationary Source Committee** Meeting of December 3, 2007

CHAIR: S. HAGGERTY

J. Broadbent/5052
jbroadbent@baaqmd.gov

12. Report of the **Nominating Committee** Meeting of December 5, 2007

CHAIR: M. ROSS

J. Broadbent/5052

jbroadbent@baaqmd.gov

Action (s): The Committee will recommend election of Board Officers for the 2008 term of office.

PUBLIC HEARING

13. Consider Adoption of Regulation 6, Rule 2: Commercial Cooking Equipment, Amendments to Regulation 3: Fees, Amendments to Regulation 6: Particulate Matter and Visible Emissions, and Adoption of a CEQA Negative Declaration

H. Hilken/4642

hhilken@baaqmd.gov

The Board of Directors will consider adoption of proposed Regulation 6: Rule 2: Commercial Cooking Equipment. Proposed Regulation 6, Rule 2 would regulate chain driven charbroilers at restaurants that purchase over 500 lbs of beef per week and large under-fired charbroilers at restaurants that purchase over 1000 lbs of beef per week.

OTHER BUSINESS

14. Report of the Executive Officer/APCO

15. Chairperson's Report

16. Board Members' Comments

Any member of the Board, or its staff, on his or her own initiative or in response to questions posed by the public, may: ask a question for clarification, make a brief announcement or report on his or her own activities, provide a reference to staff regarding factual information, request staff to report back at a subsequent meeting concerning any matter or take action to direct staff to place a matter of business on a future agenda. (Gov't Code § 54954.2)

17. Time and Place of Next Meeting - 9:45 a.m., Wednesday, December 19, 2007- 939 Ellis Street, San Francisco, CA 94109

18. Adjournment

CONTACT CLERK OF THE BOARDS - 939 ELLIS STREET SF, CA 94109

(415) 749-4965

FAX: (415) 928-8560

BAAQMD homepage:

www.baaqmd.gov

- To submit written comments on an agenda item in advance of the meeting.
- To request, in advance of the meeting, to be placed on the list to testify on an agenda item.
- To request special accommodations for those persons with disabilities. Notification to the Executive Office should be given at least 3 working days prior to the date of the meeting so that arrangements can be made accordingly.

BAY AREA AIR QUALITY MANAGEMENT DISTRICT

Memorandum

To: Chairperson Mark Ross and Members
of the Board of Directors

From: Jack P. Broadbent
Executive Officer/APCO

Date: November 26, 2007

Re: Board of Directors' Draft Meeting Minutes

RECOMMENDED ACTION:

Approve attached draft minutes of the Board of Directors meeting of November 7, 2007.

DISCUSSION

Attached for your review and approval are the draft minutes of the November 7, 2007 Board of Directors' meeting.

Respectfully submitted,

Jack P. Broadbent
Executive Officer/APCO

BAY AREA AIR QUALITY MANAGEMENT DISTRICT
939 ELLIS STREET – SAN FRANCISCO, CA 94109

Draft Minutes: Board of Directors' Regular Meeting – November 7, 2007

Call To Order

Opening Comments: Chair Mark Ross called the meeting to order at 9:50 a.m.

Roll Call: Present: Mark Ross, Chair, Tom Bates (10:03 a.m.), Harold Brown, Chris Daly, Erin Garner, Jerry Hill, Carol Klatt, Patrick Kwok, Janet Lockhart, Jake McGoldrick (9:52 a.m.), Nate Miley, Michael Shimansky, John Silva, Pamela Torliatt, Gayle B. Uilkema, Brad Wagenknecht.

Absent: Dan Dunnigan, John Gioia, Scott Haggerty, Yoriko Kishimoto, Liz Kniss, Tim Smith.

Pledge of Allegiance: The Board of Directors recited the Pledge of Allegiance.

Chair Ross stated that this was Director Kwok's last day on the Board and thanked him for his service and participation on the Board of Directors.

Director Jake McGoldrick arrived at 9:52 a.m.

Commendation/Proclamation: The Board of Directors recognized Director Patrick Kwok for his outstanding service on the Board of Directors and presented him with a plaque.

Chair Ross noted that there was one member of the public requesting to speak on Consent Calendar Item 7. The following individual then spoke on the item:

Jack Bean
Pleasant Hill, CA

Consent Calendar (Items 1 – 8)

1. Minutes of October 3, 2007
2. Communications – *Information only.*
3. Quarterly Report of Air Resources Board Representative
4. District Personnel on Out-of-State Business Travel

In accordance with Section 5.4(b) of the District's Administrative Code, Fiscal Policies and Procedures Section, the Board is hereby notified that the memoranda in the meeting packet lists District personnel who traveled on out-of-state business.

5. Consider Approval of Resolution Authorizing the Use of an Optional Benefit with the California Public Employees' Retirement System Pursuant to Government Code Section 20903

The Board of Directors considered approval of resolution authorizing use of an optional benefit with the California Public Employees' Retirement System pursuant to Government Code Section 20903.

6. Set Public Hearing for December 5, 2007 to Consider Adoption of new District Regulation 6, Rule 2: Commercial Cooking Equipment, amendments to Regulation 3: Fees, amendments to Regulation 6: Particulate Matter and Visible Emissions, and Adoption of a CEQA Negative Declaration

Proposed Regulation 6, Rule 2 would regulate chain driven charbroilers at restaurants that purchase over 500 lbs of beef per week and large under-fired charbroilers at restaurants that purchase over 1000 lbs of beef per week. A proposed exemption is provided for those restaurants that do not charbroil at least 80% of the beef purchased. Equipment registration fees, adopted in June, 2007, are proposed to be lowered due to a reduction in expected program costs, and amendments to Regulation 6: Particulate Matter and Visible Emissions renumber and rename the rule.

7. Consider Adjusting the District's Maximum Contribution Declared to California Public Employees' Retirement System (CalPERS)

The Board of Directors considered approval of a resolution adjusting the District's Maximum Medical Contribution declared to CalPERS for management, confidential, represented, and miscellaneous employees and retirees.

8. Considered Approval of Request to Amend Signature Authorization

The Board of Directors considered approval of staff recommendation to grant Jeffrey M. McKay, Deputy Air Pollution Control Officer, authorization to sign orders drawn by the District.

Board Action: Director Hill moved approval of Consent Calendar items 1 through 8; seconded by Director Wagenknecht; carried unanimously with the following Board members voting:

AYES: Brown, Daly, Garner, Hill, Klatt, Kwok, Lockhart, McGoldrick, Miley, Shimansky, Silva, Torliatt, Uilkema, Wagenknecht, Ross.

NOES: None

ABSENT: Bates, Dunnigan, Gioia, Haggerty, Kishimoto, Kniss, Smith.

Adopted Resolution No. 2007-12: A Resolution of the Board of Directors of the Bay Area Air Quality Management District Granting Another Designated Period for Two Years of Additional Service Credit

Adopted Resolution No. 2007-13: Resolution Fixing the Employee's Contribution Under the Public Employees' Medical and Hospital Care Act

Adopted Resolution No. 2007-14: A Resolution Notifying the County Treasurer and County Controller of San Mateo County of a Change in Authorized Signatures

Committee Reports and Recommendations

9. Report of the Stationary Source Committee Meeting of October 29, 2007

Director Shimansky presented the report and stated that the Committee met on Monday, October 29, 2007.

One member of the public spoke under the Public Comment Period regarding air pollution in the Southeast section of San Francisco.

Director Tom Bates arrived at 10:03 a.m.

The Committee received a status report regarding the Lennar Bay View Hunters Point Parcel A redevelopment project. The presentation included information on naturally occurring asbestos, Lennar's Asbestos Dust Mitigation Plan, air monitoring at the site, potential health risks in the surrounding community, and inspection and enforcement actions at the site. Twenty-one members of the public spoke on this agenda item expressing concerns over naturally occurring asbestos dust emissions from the grading operations, past violations cited by the Air District, and general health concerns expressed by residents of the Bayview-Hunters Point area. Direction was given to staff to pursue penalties for Lennar's violations of Air District requirements; the Air District will be enhancing air monitoring and amending the Asbestos Dust Mitigation Plan.

A brief report on proposed amendments to Regulation 9, Rule 6: Nitrogen Oxides from Natural Gas-Fired Water Heaters was presented to the Committee. The public hearing for Board approval of the amendments will be held today.

The next meeting of the Committee is scheduled for 9:30 a.m., Monday, December 3, 2007.

Board Action: Director Shimansky moved that the Board of Directors' approve the report of the Stationary Source Committee; seconded by Director Daly; carried unanimously without objection.

Public Comment Period: Chair Ross noted that the public comment period had been overlooked earlier in the meeting. Chair Ross called for Public Comments and there were none.

10. Report of the Mobile Source Committee Meeting of October 31, 2007

Action(s): The Committee recommended Board of Directors' approval of the following:

- A) Fiscal Year 2007/2008 Transportation Fund for Clean Air (TFCA) Regional Fund grant awards listed in Attachment 1, totaling \$10,348,655; and*
- B) Reallocation of any funds remaining from the \$1,000,000 in FY 2007/2008 TFCA Regional Funds set aside for clean-air vehicle advanced technology demonstration projects back to the TFCA Regional Fund.*

Director McGoldrick presented the report and stated that the Committee met on Wednesday, October 31, 2007.

Staff presented a report on the Transportation Fund for Clean Air (TFCA) Regional Fund grant awards for fiscal year 2007/2008. Staff noted that they would be working with sponsors of projects that did not achieve the minimum point score and are not currently recommended for funding. Staff will report back to the Committee on any of these projects that would be eligible for funding in the future. The Committee recommends Board of Directors' approval of the following:

- A) Fiscal year 2007/2008 TFCA Regional Fund grant awards listed in Attachment 1 of the staff report, totaling \$10,348,655; and
- B) Reallocation of any funds remaining from \$1 million in fiscal year 2007/2008 TFCA Regional Funds set aside for clean-air vehicle advanced technology demonstration projects back to the TFCA Regional Fund.

The Committee received an update on the state-wide Goods Movement Emission Reduction Program. The update included information on the Program targets and themes, structure, and the timeline. Staff will provide additional updates at future meetings of the Committee.

The next meeting of the Committee is tentatively scheduled for Monday, December 10, 2007.

Board Action: Director McGoldrick moved that the Board of Directors' approve the recommendations and report of the Mobile Source Committee; seconded by Director Shimansky; carried unanimously without objection.

Chair Ross stated that a request had been made to hear agenda item 12 next and he so ordered.

Public Hearing

12. Public Hearing to Consider Adoption of Amendments to District Regulation 9, Rule 6: Nitrogen Oxides from Natural Gas-Fired Water Heaters, and Adoption of a CEQA Negative Declaration

Proposed amendments to Regulation 9, Rule 6 will expand the scope of the rule to regulate NOx emissions from larger water heaters and small boilers, include currently exempt mobile home water heaters and commercial spa and pool heaters and establish more stringent NOx emission limits for all affected equipment.

Guy Gimlen, Air Quality Engineer, presented the report reviewed the background of Regulation 9, Rule 6. Mr. Gimlen stated that the regulation is a “point of sale” type regulation requiring emission controls on new units. The current NOx emissions are approximately 3.3 tons per day from water heaters. The proposed amendments to the rule will fulfill the Air District’s commitment to reduce NOx emissions in the 2005 Ozone Strategy under Control Measure 13. Mr. Gimlen provided pictures of a 100,000 Btu/hr water heater and a 1,000,000 Btu/hr steam boiler, which are two of the large devices that are currently regulated.

The rule amendment proposals would reduce current residential water heater NOx limits from 40 ng/joule down to 10 ng/joule starting January 1, 2009 for new heaters. The NOx limits are written as “output” based standards. The amendments also include larger water heaters and small boilers up to 2MM Btu/hr. Mr. Gimlen reviewed the costs and emission reductions that will be achieved. Total NOx reductions would amount to 2.9 tons per day. The rule development process was reviewed.

Mr. Gimlen stated that staff recommends that the Board of Directors adopt the proposed amendments to Regulation 9, Rule 6: Nitrogen Oxides from Natural Gas-Fired Water Heaters and approve the CEQA Negative Declaration for the proposed amendments.

There was discussion on the January 2009 implementation date, the efficiency of the equipment, incentives, solar water heaters, and point-of-need water heaters.

Chair Ross opened the public hearing at 10:34 a.m. and the following individual came forward and spoke on the item:

Ed Nordstrom
Director, Technical & Regulatory Affairs
GAMA
Providence, RI 02903

Jack Broadbent, Executive Officer/APCO, addresses the concerns raised by Mr. Nordstrom and stated that the time frame in the regulation is sufficient to address products that are in the stream and for the manufacturers to gear up.

Chair Ross closed the public hearing at 10:44 a.m.

Board Action: Director Torliatt moved Board of Directors’ approval of the staff recommendation; seconded by Director Wagenknecht; carried unanimously with the following Board members voting:

AYES: Bates, Brown, Daly, Garner, Hill, Klatt, Kwok, Lockhart, McGoldrick, Miley, Shimansky, Silva, Torliatt, Uilkema, Wagenknecht, Ross.

NOES: None.

ABSENT: Dunnigan, Gioia, Haggerty, Kishimoto, Kniss, Smith.

Adopted Resolution No. 2007-15: A Resolution of the Board of Directors of the Bay Area Air Quality Management District Amending District Regulation 9, Rule 6: Nitrogen Oxides from Natural Gas-Fired Water Heaters and Small Boilers and Adopting a CEQA Negative Declaration for the Project

Presentation

11. Summary of 2007 Ozone Season and Overview of Upcoming Spare the Air Tonight Campaign

Staff provided a summary of the 2007 Ozone Season, background information on particulate matter for the upcoming winter season, and an overview of the upcoming Spare the Air Tonight campaign.

Gary Kendall, Director of Technical Services, presented the report and reviewed the 2007 ozone exceedances for the Bay Area and reviewed preliminary data through October 31, 2007 for the major California air basins. Mr. Kendall reviewed a chart entitled Bay Area Ozone and Maximum Temperature Trends which lists the number days greater than 99° F and the number of days exceeding the National Ozone Standard.

Mr. Kendall discussed the attainment status of the 8-hour national standard (85 ppb) at five monitoring stations and the attainment status of the 8-hour national standard forecast into the future. The Environmental Protection Agency (EPA) has proposed revising the ozone standard from 85 ppb to 70-75 ppb. Mr. Kendall stated that the 2005 Ozone Strategy has 38 Control Measures, 20 Further Study Measures, and there will be an update in 2008. Mr. Kendall reviewed the Bay Area VOC and NOx emission trends in tons per day from 1980 through 2020.

Mr. Kendall presented a summary of the 2006/2007 winter PM_{2.5} season, Bay Area PM_{2.5} trends, and the composition of winter PM_{2.5}. In reviewing the facts about Bay Area PM_{2.5}, Mr. Kendall stated that the Bay Area does not meet the new PM_{2.5} standard, the PM_{2.5} standard is only exceeded during the winter, and wood smoke is the largest component of winter PM_{2.5}. An overview of PM control measures was provided to the Board.

There was discussion on the Air District's CARE Program and PM reductions at specific "hot spots" and how fires like those in Southern California affect the PM standards. Mr. Kendall stated that the Air District can request that EPA flag extraordinary events like the fires.

Mr. Broadbent added that the Air District is gearing up for the Spare the Air Tonight program and is conducting numerous workshops on the proposed wood smoke rule.

Closed Session (The Board adjourned to Closed Session at 11:04 a.m.)

13. Conference with Legal Counsel: *Existing litigation*

Pursuant to Government Code Section 54956.9(a), a need existed to meet in closed session with legal counsel to consider the following cases:

- A) **Hornblower Cruises and Events v. California Air Resources Board, Bay Area Air Quality Management District, David Burch, et al.**, Superior Court of the County of San Francisco, Case No., CGC-07-464286
- B) **San Francisco Chapter of the A. Philip Randolph Institute, et al. v. United States Environmental Protection Agency, Bay Area Air Quality Management District, Mark Ross**, United States District Court, Northern District of California, Case No. C 07 4936 JCS

Open Session (The Board reconvened to Open Session at 11:12 a.m.)

Brian Bunger, Legal Counsel, reported that the Board met with legal counsel in Closed Session on items 13 A and 13 B. A status report was provided on the items and the Board provided direction to counsel.

Other Business

- 14. Report of the Executive Officer/APCO – Jack Broadbent, Executive Officer/APCO reported on the following:
 - A) The public hearing on the Charbroiler rule will take place at the next Board meeting.
- 15. Chairperson’s Report – Chair Ross reported on the following:
 - A) The November 21st Board meeting is cancelled and the next Regular Board meeting is scheduled for December 5, 2007.
 - B) In early October, he attended the Air & Waste Management Association’s People to People Conference in China.
- 16. Board Members’ Comments – Director Garner reported that in early October, he also attended the AWMA’s People to People Conference in China.
- 17. Time and Place of Next Meeting – 9:45 a.m., Wednesday, December 5, 2007 – 939 Ellis Street, San Francisco, CA 94109
- 18. Adjournment – The meeting adjourned at 11:17 a.m.

Mary Romaidis
Clerk of the Boards

BAY AREA AIR QUALITY MANAGEMENT DISTRICT

Memorandum

To: Chairperson Mark Ross and Members
of the Board of Directors

From: Jack P. Broadbent
Executive Officer/APCO

Date: November 26, 2007

Re: Board Communications Received from November 7, 2007 through December 4, 2007

RECOMMENDED ACTION:

Receive and file.

DISCUSSION

A list of Communications received by the Air District from November 7, 2007 through December 4, 2007, if any, will be at each Board member's place at the December 5, 2007 Regular Board meeting.

Respectfully submitted,

Jack P. Broadbent
Executive Officer/APCO

To: Chairperson, Mark Ross and Members
of the Board of Directors

From: Jack P. Broadbent
Executive Officer/APCO

Date: November 7, 2007

Re: Report of Division Activities for the Months of July 2007 - September 2007

**FINANCE, ADMINISTRATION AND
INFORMATION SERVICES DIVISION – J. MCKAY, DIRECTOR**

The Air Resources Board, the Bureau of State Audits and the Department of Finance each issued final reports on their respective state-wide audits of the Carl Moyer Program. In response to these reports the Air District has provided detailed plans for improved controls, and also for remediation of some prior projects. In response to its very favorable review of the Air District's plan and of the Air District's newly implemented procedures, the Air Resources Board has canceled its plans for quarterly audits of the Air District's Carl Moyer Program. The Department of Finance follows the ARB schedule. The Bureau of State audits requested three month, six month and one year reports. The three month report has been submitted and accepted.

COMPLIANCE AND ENFORCEMENT – K. WEE, DIRECTOR

Enforcement Program

On August 1, staff performed night surveillance at a bus yard in San Jose with Air Resources Board (ARB) staff, in a continuing ARB enforcement action following up on complaints of idling buses. Staff documented several violations and enforcement action was taken. Staff participated in the San Francisco Board of Supervisors Land Use and Economic Opportunity Subcommittee meeting on July 9, 2007, San Francisco Board of Supervisors meeting on July 31, and the Hunters Point Citizen's Advisory Committee Meeting on September 10, 2007 to present information and respond to questions and concerns about the Naturally Occurring Asbestos at the Lennar BVHP Parcel A redevelopment project. On July 26, 2007 staff attended a public scoping meeting held by Santa Clara County, to discuss potential impacts of renewal of the Hanson Cement, Cupertino, quarry reclamation plan. On September 24, 2007 staff met with representatives for Pacific Steel Castings (PSC) to discuss ongoing compliance issues at PSC and their progress on their Odor Management Plan.

Compliance Assurance Program

Inspection requirements for EPA grant commitments were completed for the routine, 2-year reporting cycle. The District approved all five petroleum refinery Flare Minimization Plans (FMPs) and staff is now working on procedures for the FMP Annual Update process. Through the FMP process, the Air District required the installation of additional refinery vent gas compressors that will reduce flaring and the associated emission impacts of flaring. Staff attended the California Air Pollution Officers Association (CAPCOA) Vapor Recovery Committee meeting in Sacramento from July 18-20, 2007. Staff participated in monthly Trucker Work Group meetings this quarter at the Port of Oakland that seek to reduce diesel particulate matter impacts in the Port.

Compliance Assistance

Staff presented information to San Mateo and Contra Costa County Environmental Health Inspectors on August 11 and August 20, respectively, about upcoming State gasoline vapor recovery requirements. On August 28 staff discussed Enhanced Vapor Recovery (EVR) issues at a Sacramento meeting with representatives of the Western States Petroleum Association (WSPA), the California Independent Oil Marketers Association (CIOMA), CAPCOA, and the Air Resources Board (ARB). On September 25 staff hosted an informational meeting conducted by the ARB for city and county regulatory agencies regarding State vapor recovery requirements. On August 29, staff conducted a Compliance School for individuals that need to conduct marsh burns and presented impacts of marsh burning, a review of the burn plan approval process, existing and new procedures for burners to follow, and compliance assistance materials to help burners conduct a successful and legal burn. Translation from the Korean, Mandarin and Vietnamese languages was provided for Division activities during the month of July.

Operations

The draft proposed Regulation 6, Rule 3, "Wood Burning Devices," has been posted to the District webpage and seven workshops for the rule will begin in November, including webcasting. The new radio system hardware and software integration has been completed and all microwave and backup systems are online and functioning. Six new inspectors have been hired and will have approximately nine weeks of combined office and field training.

(See Attachment for Activities by County)

ENGINEERING DIVISION – B. BATEMAN, DIRECTOR**Permit Activity Summary**

In the 3rd quarter 2007, 417 new permit applications were received: 291 standard New Source Review applications, 94 Gasoline Dispensing Facility applications, 23 Title V applications, and 9 Banking applications. During this period, the Division issued 165 Authorities to Construct and issued 295 Permits to Operate.

Toxics Program

A total of 95 Health Risk Screening Analyses (HRSAs) were completed during the 3rd quarter. The majority of these HRSAs were for diesel engine emergency generators, soil remediation projects, and gasoline stations. Staff also completed HRSAs for a pyrolysis furnace at Alco Iron & Metal (San Leandro), and for a drum reclamation furnace at Container Management Service (Richmond), based on requests from community groups. Staff is continuing work on an HRSA for a major modification to Chevron Refinery in Richmond.

Pacific Steel Casting Company (Berkeley) submitted a Health Risk Assessment (HRA) required by the Air Toxics Hot Spots Program in July. Staff completed a preliminary review of the HRA, and the document was revised and resubmitted based on District comments. The revised HRA was provided to Cal/EPA's Office of Environmental Health Hazard Assessment (OEHHA) for review. The District also made the HRA available for public comment through the District website, with copies also provided to the local public libraries. District staff intends on conducting a community meeting to discuss the HRA in January 2008.

Staff participated in several meetings of the CAPCOA Toxics and Risk Management Committee (TARMAC). TARMAC has been active in reviewing proposed ATCMs (e.g., for diesel engines), resolving AERMOD and HARP modeling issues, and developing new health risk assessment guidelines for CEQA and Air Toxics Hot Spots Program. Staff also participated in CAPCOA's symposium on "Health Impacts of Air Pollution on Communities" in Carson, California.

Permit Evaluation Program

Staff continued to evaluate several major refinery permit applications during the 3rd quarter. Final changes were made to the permit evaluation for ConocoPhillips' Clean Fuels Expansion Project based on public comments received, and the Authority to Construct was prepared for issuance in early October. Staff continued review of Chevron's Energy and Hydrogen Renewal Project, but the Authority to Construct for this project is not expected to be issued until early 2008, due to delays in certification of the project's Environmental Impact Report by the City of Richmond.

Staff continued to evaluate several power plant permit applications. The Russell City Energy Center is a 600-MW natural gas fired combined cycle plant proposed by Calpine Corporation in Hayward. The Air District issued the Final Determination of Compliance (FDOC) for this project in late June, and the California Energy Commission (CEC) approved the project's Certification on September 26. Air District staff is continuing to work with Calpine on the details of a PM mitigation plan adopted as a condition of Certification, including administration of a wood stove and fireplace retrofit program in the project area. Staff also continued work on a permit evaluation for the Eastshore Energy Center, a proposed 115-MW natural gas fired reciprocating engine facility in Hayward which would provide local energy reliability for the Bay Area in addition to voltage support to the regional transmission system during peak demand hours. The FDOC for the Eastshore project is expected to be issued in mid-October, and the CEC has scheduled evidentiary hearings for the project in December. The Air District issued a temporary Permit to Operation (TPO) to Dynegy, LLC to test fire biofuel blends in an existing gas turbine at their Oakland facility. The TPO is valid for a three-month period, during which Dynegy will conduct performance and emissions testing.

Staff completed the evaluation of a permit application for a major new landfill gas-to-energy facility at the Ox Mountain Landfill in Half Moon Bay. An Authority to Construct and PSD permit were issued for this project in August. The project will produce electricity from landfill gas that is currently being flared, thereby reducing greenhouse gas emissions.

Staff completed the evaluation of a permit application submitted by Pacific Steel Casting (Berkeley), related to additional capture and control of fugitive PM emissions at their Plant 3 electric arc furnace. This project was a condition of a Settlement Agreement between the company and the District. The District also issued a permit to improve the capture and control of fugitive PM emissions at the facility's Plant 1 electric arc furnace.

Staff of the Engineering and Legal Division continued discussions with EPA Region IX on a proposed PSD Delegation Agreement. Most issues have been resolved, and both parties should sign the final delegation agreement in the 4th quarter 2007.

Staff continued work in implementing CARB's stationary and portable diesel engine Airborne Toxic Control Measures (ATCMs). These ATCMs apply to thousands of diesel engines in the Bay Area, and the rules provide for a variety of compliance options. A multi-Division workgroup has made considerable progress in identifying and resolving issues related to ATCM implementation.

Title V Program

In the 3rd quarter 2007, the following Title V permit actions were finalized: (1) four administrative amendments, (2) seven minor revisions, and (3) three renewals. Significant progress was also made in preparing the next round of significant revisions to the Title V permits for the five Bay Area refineries.

Engineering Special Projects Program

Engineering Division staff continued to participate in the Production System Conversion project, including providing technical input on various existing processes including the authority to construct/permit to operate process, the Title V permit process, the flare report inspection/review process, and the permit renewal process. Work plans for improving the processes were finalized, and the Requirements/Design/Build phase of the project has begun with the preparation of policy documents for a number of initiatives.

Engineering Division staff continued to actively participate in the District's Flare Workgroup. The Flare Workgroup is addressing how to handle the annual "renewal" of the Flare Minimization Plans (FMPs) and the updates associated with permitting new and modified sources that impact flaring.

Staff prepared a comment letter to EPA on proposed NSPS Subpart J, Standards of Performance for Petroleum Refineries. The comment letter focused on (1) flare issues, (2) proposed limits for refinery heaters, sulfur recovery units, and fluid catalytic cracking units (3) treatment of peripheral combustion sources, and (4) the procedures for establishing parametric limits.

Engineering Division staff provided input to CARB to support their efforts to comply with the AB-32 requirements for Mandatory Greenhouse Gas Emissions Inventory Reporting. Several meetings on this topic were attended, and written materials on District data reporting requirements were prepared.

Staff also participated in a workshop held by CARB on a proposed regulation to limit emissions from Ocean-Going Vessel (OGV) Main Engines. The workshop also covered the status of litigation between the Pacific Merchant Shipping Association and CARB over the OGV Auxiliary Engine Fuel Regulation.

LEGAL DIVISION – B. BUNGER, DISTRICT COUNSEL

In the 1st Quarter of Fiscal Year 2007-08, the Air District Counsel's Office received 183 Violations reflected in Notices of Violation (NOVs) for processing.

In the 1st Quarter of Fiscal Year 2007-08 Mutual Settlement Program staff initiated settlement discussions regarding civil penalties for 124 violations reflected in NOVs. In addition, Mutual Settlement Program staff sent 12 Final 30 Day Letters regarding civil penalties for 16 Violations reflected in NOVs. Finally, settlement negotiations by Mutual Settlement Program staff resulted in collection of \$62,459 civil penalties for 75 Violations reflected in NOVs.

In the 1st Quarter of Fiscal Year 2007-08, settlement negotiations by counsel in the Air District Counsel's Office resulted in collection of \$914,589 in civil penalties for 54 Violations. Additionally, the Air District received \$333,333.50 from a federal Consent Decree relating to a nationwide enforcement effort against Rhodia, Inc. The Air District also received \$150,000 from Pacific Steel Casting (PSC) to settle the Air District's claim related to PSC's violation of H & S code 44381 for failing to timely deliver portions of the health risk assessment for PSC's facility. In addition, the Air District received \$125,000 in settlement proceeds related to the lawsuit filed against Archstone for failing to properly manage asbestos at its multi-unit rental properties in the Bay Area.

(See Attachment for Penalties by County)

PLANNING DIVISION – H. HILKEN, DIRECTOR

Community Air Risk Evaluation (CARE) Program

Staff convened a CARE Task Force Meeting to discuss: 1) development of emissions estimates for truck-related businesses and construction in West Oakland; 2) an upcoming on-road truck survey; 3) the Richmond BNSF Railyard HRA; and 4) CARE mitigation strategies. Staff participated in a Technical Working Group meeting in Oakland to discuss the summary of diesel PM emissions for the West Oakland HRA. Staff participated in a Community Meeting on the diesel PM emission inventory at the West Oakland Senior Center. Staff participated in a second Community Meeting for the Richmond BNSF Railyard Health Risk Assessment (HRA). Staff met with staff of the Bay Planning Coalition and consultants to discuss opportunities to collaborate on preparing detailed emissions estimates of regional maritime activity. Staff presented information on the CARE program at the CAPCOA Conference on Health Impacts of Air Pollution in Communities, held in Carson, CA. Staff continued to plan and prepare for a survey of on-road trucks in West Oakland and a for a measurement study to monitor toxic air contaminants in West Oakland. Staff was informed by EPA that the District's Community-scale Toxic Measurements Grant will be funded with an award of about \$300,000 to conduct measurements in West Oakland. Staff is exploring the possibility of working with the Port of Oakland to expand the monitoring project.

Rule Development Program

Staff presented proposed amendments to the Board of Directors on District Regulation 9, Rule 8: Nitrogen Oxides and Carbon Monoxide from Stationary Internal Combustion Engines at a public hearing on July 25, 2007. The Board adopted the amendments. Staff prepared workshop materials for an October workshop on proposed Regulation 6, Rule 2: Commercial Cooking Equipment. Staff provided presentations to the Stationary Source Committee on proposed Reg. 6-2 and proposed amendments to Regulation 9, Rule 6: Nitrogen Oxides from Natural Gas-Fired Water Heaters. Staff participated in conference calls hosted by ARB staff on development of a Suggested Control Measure for Architectural Coatings (District Reg. 8-3). Staff met with representatives from CCEEB regarding stationary internal combustion engines, Lyondell Chemical regarding tertiary butyl acetate, California Restaurant Association and Golden Gate Restaurant Association regarding proposed Reg. 6-2, DuPont Automotive Coatings, the National Paint and Coatings Association and Dent-Pro Corp. regarding automotive refinishing, Hewlett-

Packard regarding digital printing, and WSPA and a number of refineries regarding emissions from cooling towers and gasoline bulk terminal and bulk plants.

Air Quality Planning Program

Staff organized and hosted a meeting of approximately 25 local, State and international organizations that provide assistance to local governments for developing and implementing climate protection programs. Staff met with PG&E, ICLEI, and MTC to devise methodologies to estimate community wide GHG emissions and to devise a data template for reporting jurisdiction wide GHG emissions. Staff organized and hosted a GHG emission inventory development workshop for local government staff in San Mateo and Santa Clara counties. 35 individuals from 22 cities attended. At the workshop, cities developed their community wide GHG emission inventory. Staff finalized guidelines for the Climate Protection Grant Program and opened the application period from September 21st through November 9th. Staff conducted three public workshops for potential grant applicants. Staff led the CAPCOA Planning Managers CEQA & Climate Change Subcommittee that was formed to develop greenhouse gas CEQA threshold concepts, analytical methodologies and mitigation strategies that could be used in CEQA documents to evaluate the potential impacts from greenhouse gases from new development. Staff made numerous presentations to the CAPCOA Climate Protection Committee, the CAPCOA Board of Directors and the CAPCOA membership at the fall conference on the CEQA & Climate Change white paper developed by the Subcommittee. Staff continued working with curriculum development contractor on the completion of the pilot “Protect Your Climate Curriculum” for 4th and 5th grades. Training began for 13 teachers in five counties.

Staff collaborated with MTC on preparation of the T-2035 RTP update, including providing recommended air quality performance targets regarding reductions of CO₂ and PM. Staff continued to participate in the FOCUS (Focusing our Vision) regional smart growth initiative in collaboration with ABAG, MTC, and BCDC, including outreach meetings in each Bay Area county and solicitation of applications from local agencies to nominate priority development areas in their communities. Staff submitted comments on the Coyote Valley Specific Plan DEIR. Staff met with City of Richmond staff and Chevron consultants to discuss District comments on the Chevron Energy and Hydrogen Renewal Project DEIR. Staff made a presentation at the State of the Estuary Conference regarding the connection between air pollution and water pollution.

Mobile Sources

Staff participated in meetings of the Port of Oakland Maritime Air Quality Improvement Plan Task Force. Staff participated in ARB workshops on proposed ATCMs for: shore power for ocean-going vessels; fuels for ocean-going vessels; and trucks operating at maritime ports and intermodal facilities. Staff provided testimony at a hearing of the Golden Gate Bridge, Highway and Transit District Board regarding air quality benefits of low-emitting ferry vessels.

Research and Modeling Program

Staff continued to work with Sonoma Technology, Inc., an Air District contractor, to develop an ammonia emissions inventory for the Bay Area that will be used for particulate matter (PM) modeling. Staff continued to work with contractors at UC Davis to investigate wintertime meteorological conditions conducive to high PM levels in the Bay Area. Staff continued working with scientists from Lawrence Livermore National Laboratory to investigate likely future climate change scenarios and their effects on Bay Area air quality. Staff refined estimates of PM emissions from cooking in the Bay Area. Staff completed estimates of emissions from wood burning in the Bay Area, based on a telephone survey. The new data will be used for PM modeling. Staff reviewed a Health Risk Assessment prepared for Pacific Steel Casting, Inc. and provided comments to the District's Engineering Division. A computer cluster system was purchased to support the District's ozone, particulate matter, and toxics modeling needs.

Special Projects

Staff continued working on preparing the Base Year 2005 emission inventory and responding to requests on emissions data. Staff started work on updating the Green House Gas emission inventory for the Bay Area. Staff prepared detailed 2005 point source emission data for the updated CARE emission inventory. Staff started work on preparing the 2006 point source emission report for ARB submittal. Staff attended in person or by web cast numerous committee meetings and workshops on implementation of AB 32, the California Global Warming Solutions Act. Staff participated in conference calls on oceangoing vessels' emission inventory development related to upcoming ARB regulations.

OUTREACH AND INCENTIVES – J. COLBURN, DIRECTOR

Spare the Air

For the July through September quarter, the District issued two Spare the Air advisories on August 29 and 30. The associated media coverage resulted in 126 print articles and 93 television and radio stories, for an estimated free advertising value of more than \$687,000 for the two day period. Estimates from local transit agencies showed a 20 percent increase in regional ridership on the two free transit days. Approximately 54,000 AirAlert subscribers were alerted in advance by e-mail, and 1,500 local employers were notified by fax. The overall Spare the Air program outreach for the quarter resulted in over 232 print articles and 167 television and radio stories.

The Spare the Air Employer Program team planned a summit entitled "Building on Success" held October 2 in South San Francisco. The goal of the Summit was to educate and inspire representatives from public and private employers across the Bay Area. A panel representing five local businesses discussed how they had implemented clean air policies and practices at their workplaces. Panelists addressed topics such as how they had overcome challenges; the benefits to their businesses, employees and clients; and sustainable workplace behaviors that help clean the air and protect the climate.

Spare the Air Tonight – Staff continued preparing the wintertime campaign materials for the upcoming season. Wintertime activities include a newly revised Wood Smoke Handbook, new public service announcements recorded by the Executive Officer, an expanded survey of public attitudes about wood burning, expanded outreach to Spanish and Mandarin speakers, and a children’s air quality coloring book.

Public Information and Media

During the quarter, the Air District issued ten press releases including: on July 10, the Boards approval of the refinery flare minimization plan, on August 10, the kickoff event for the Air District supported Napa plug-in hybrid school bus, on August 24, an announcement of the Healthy Air Partnership with the American Lung Association, and the announcement of the Air District’s 1.5 million climate change grant program, among others.

On July 19, the Air District sponsored a free preview of the environmental family film *Arctic Tale* in Walnut Creek. The event was attended by approximately 200 community members. Staff made brief opening remarks and staffed an informational table at the event.

Also on July 19 at the Climate Protection Committee meeting, staff presented a summary of the Air District’s climate protection outreach activities. These include integrating climate protection into the Spare the Air campaign, developing the District’s youth outreach program, producing climate protection collateral items, and developing an upcoming climate protection radio campaign.

Staff responded to media inquiries regarding the announcement of Flare Minimization Plans prepared by the five Bay Area petroleum refineries, subject to the Air District’s Regulation 12, Rule 12, Flares at Petroleum Refineries. Staff responded to media inquiries regarding the approved plans.

Staff issued a press release on August 24 announcing the Air District’s Healthy Air Partnership with the American Lung Association of California (ALAC). This partnership, highlighting the relationship between air quality and public health, it is the first of its kind between air districts and the ALAC.

On September 5, staff issued a news advisory warning the public about the regional air quality impacts of two large Northern California wildfires, one located north of the district in Plumas County and one burning in Henry Coe State Park in Santa Clara County. Staff responded to 41 media inquiries and numerous calls from schools and the public. A public advisory notice was placed on the Spare the Air website.

The Air District issued a press release the week of September 17 regarding the settlement of an asbestos-related lawsuit. The sum of \$125,000 will be collected from a prominent real estate management company for using uncertified workers to remove asbestos-containing material from Bay Area apartment buildings.

Community Outreach

Staff attended the Truck Incentive Work Group meeting in West Oakland on July 25. Participants discussed strategies for developing an effective and equitable truck program while looking at the State and the Port of Oakland to provide an estimated timeline for decisions for 1B bond allocations for the port truck programs.

On August 29, staff spoke about the District's approach to environmental justice as part of a panel for the North Richmond Environmental Justice Leadership Academy. Other panelists included Richmond Mayor Gayle McLaughlin and staff from Director Gioia's office.

On September 15 staff coordinated two focus groups of elementary and junior high students at Yerba Buena Center for the Arts in San Francisco. Students provided input to the District on images and messages dealing with climate change, particulate matter and collateral upon which the images and messages may be placed. This effort will assist the District to form effective messages for youth outreach.

On September 21, more than 300 leaders of local government, business, youth, environment, faith, and social justice organizations from the nine Bay Area counties converged at the Climate All-Stars Conference held at St. Mary's Cathedral. The goal of this one-day event was to inspire innovative climate protection action and to identify opportunities for greater regional collaboration.

Staff participated in a round-table discussion at the East Palo Alto Health Expo and Cultural Fair on Saturday September 29. Participants included Ira Ruskin, Assemblymember, District 21, Ruben Abrica, East Palo Alto Council Member, and Srija Srinivasan, Director of Health Policy, Planning & Promotion, San Mateo County Health Department.

Staff publicized and coordinated meetings for the Climate Protection Grant Program Workshops. Details of the workshops were sent to regional employers, NGOs, resource team members, educators, public agencies, and community members.

Grant Programs

On July 18, staff recommended and the Mobile Source Committee approved the Fiscal Year 2007-2008 expenditure plans of the TFCA County Program Manager Fund that totaled 47 projects for a total of \$6.9 million. Staff also recommended amendments to certain prior fiscal year plans, which the Committee approved. On July 25, the Board approved the Committee's recommendation. Several county program managers have unallocated funds in their expenditure plans that must be allocated within 6 months of this day; the District set October 15 as a deadline to submit proposed projects for the unallocated funds.

Staff submitted to ARB the District's final Carl Moyer Program report for Program Year 7 along with annual reports for Program Years 8 and 9. On August 27, ARB issued the complete report of its 2007 audit of the District's Carl Moyer Program and the Lower Emission School Bus Program. This report included the District's response to the audit and ARB's comments on the District's response.

Staff met with the County Congestion Management Agency (CMA) Directors at their monthly meeting on August 25 in Pleasant Hill. Topics of discussion included accountability, communication, transparency, and workloads related to the TFCA Program Manager Fund. On August 30, staff sent proposed funding agreements to eight CMAs, covering expenditure plans approved by the Board on July 25 and including new provisions for insurance and revised indemnification language. Napa County has not yet provided a draft expenditure plan.

Staff presented the Vehicle Buy Back Program 2007 Annual Report to the Mobile Source Committee on September 27. The Committee approved recommendation to incorporate the new VAVR regulations, accepting model year 1986 and 1987 vehicles into the program, and increasing the funds available for the direct mail campaign to continue promoting the buy back program through December 2008.

TECHNICAL DIVISION – G. KENDALL, DIRECTOR

Air Quality

During the third quarter, the 85 ppb national 8-hr ozone standard was exceeded once, on July 5th at Livermore (91 ppb). The State 8-hr ozone standard was also exceeded on July 5th and four other days. The State 1-hr ozone standard was exceeded on three of those days.

The national 8-hr standard was exceeded on twelve days during the summer of 2006 and on only one day this summer. This was due to cooler weather this summer. For example, San Jose average temperatures from June through September were 5° F below normal. This summer, the Bay Area experienced only 6 hot days (days 99° F or warmer), while last summer had 15 hot days.

Air Monitoring

All 29 air monitoring stations were operational from July 1st through September 30th 2007, with equipment operating on routine, EPA-mandated schedules.

Meteorology and Forecasting

Second quarter 2007 air quality data were quality assured and entered into the EPA Air Quality System (AQS) database. Staff revised and updated the Technical Services Quality Management Plan and the Quality Assurance Project Plan. Staff continued to make daily air quality, Spare the Air, and burn forecasts.

Quality Assurance

The Quality Assurance (QA) group conducted regular, mandated performance audits of 81 monitors at 29 Air District air monitoring stations. QA staff completed performance audits on the Ground Level Monitoring networks at the Tesoro, Valero, and Chevron Refineries; all monitors passed the audits. Staff calibrated the ozone generator/photometer at the Lung Biology Lab at San Francisco General Hospital. Staff procured samples to begin proficiency testing of the District's Chemistry Lab, focusing on testing for aldehydes, ion analysis of PM₁₀ filters, and 6 toxic compounds. An audit procedure for Air District toxics sampler pressure and flow rates was developed and tested.

Laboratory

In addition to ongoing routine analyses, five phenolic binder samples from Pacific Steel Casting were analyzed for VOC and phenol content.

One main engine fuel sample from the ship "Maersk Buffalo" docked in the Port of Oakland was analyzed for sulfur and benzene content. One gaseous sample taken by the Oakland Fire Department Hazardous Materials Response Unit in the vicinity of fuel spill from the "Maersk Buffalo" on 9/6/07 was analyzed for total reduced sulfur and speciated hydrocarbons.

Source Test

Ongoing Source Test activities during April, May, and June of 2007 included Continuous Emissions Monitoring (CEM) Field Accuracy Tests, source tests, gasoline cargo tank testing, and evaluations of tests conducted by outside contractors. The ConocoPhillips Rodeo Refinery's open path monitor monthly reports for March, April, and May were reviewed. The Source Test Section participated in the District's Rule Development efforts for Refinery Cooling Towers, Stationary Gas Turbines, Gasoline Bulk Terminals, and Char-broilers. The Source Test Section continued its participation in the District's Business System Analysis for the new production system.

STATISTICS

Administrative Services:**Accounting/Purchasing/Comm.**

General Checks Issued	2,105
Purchase Orders Issued	763
Checks/Credit Cards Processed	4,210
Contracts Completed	58
Pieces of Mail Sent	21,624
Public Information Requests Rec'd	

Executive Office:

Meetings Attended	121
Board Meetings Held	3
Committee Meetings Held	11
Advisory Council Meetings Held	6
Advisory Council Committee Mtgs. Held	4
Hearing Board Meetings Held	2
Variances Received	4

Information Systems

New Installation Completed	4
PC Upgrades Completed	11
Service Calls Completed	640

Human Resources

Manager/Employee Consultation (Hrs.)	800
Management Projects (Hrs.)	220
Employee/Benefit Transaction	302
Training Sessions Conducted	20
Applications Processed	298
Exams Conducted	10
New Hires	5
Payroll Administration (Hrs.)	520
Safety Administration	170
Inquiries (voice/telephone/in-person)	1,200

Vehicle/Building Maintenance

Vehicle Services Completed	90
Requests for Building Services	250

Compliance and Operations Program

Asbestos Plans Rec'd	1,502
Coating and other petitions Evaluated	14
Open Burn Notifications Rec'd	30
Prescribed Burn Plans Evaluated	16
Smoking Vehicle Complaints Rec'd	4,432
Tank/Soil Removal Notifications Rec'd	35
Compliance Assistance Inquiries Rec'd	261
Green Business Reviews	38
Flare Notifications	11

Compliance Assurance Program

Industrial Inspections Conducted	1,978
GDF Inspections Conducted	585
Asbestos Inspections Conducted	329
Open Burning Inspections Conducted	15
Auto Body/Dry Cleaning Inspections Conducted	158

Engineering Division:

Annual Update Packages Started	882
Annual Update Packages Completed	1,288
Total Update Pages Entered	1,045
New Applications Rec'd	417
Authorities to Construct Issued	165
Permits to Operate Issued	295
Exemptions	30
Authorities to Construct Denied	1
Companies added to Databank During 3 rd Quarter	189

Outreach & Incentives Division:

Presentations Made	24
Responses to Media Inquiries	100
Press Releases	10
General Requests for Information	1,150
Visitors	6

STATISTICS (continued)

Compliance and Enforcement Division:**Enforcement Program**

Breakdown/monitor Excesses Investigated	115
Citizen Complaints Investigated	810
GDF Tags Issued	139
Violations Resulting in Notices of Violation	137
Violations Resulting in Notice to Comply	96
New Hearing Board Cases Reviewed	5

Technical Services:**3rd Quarter 2007 Ambient Air Monitoring**

Days Exceeding Nat'l 24-hour PM _{2.5} Std	0
Days Exceeding Nat'l 24-hour PM ₁₀ Std	0
Days Exceeding Nat'l 24-hour PM ₁₀ Std	1
Days Exceeding the Nat'l 8-hour Ozone Std	1
Days Exceeding the State 1-hour Ozone Std.	3
Days Exceeding the State 8-hour Ozone Std.	5

Ozone Totals, Jan.-Dec. 2007

Days Exceeding Nat'l 8-hour Ozone Std.	1
Days Exceeding State 1-hour Ozone Std.	4
Days Exceeding State 8-hour Ozone Std.	9

Particulate Totals, Jan.-Dec. 2007

Days Exceeding Nat'l 24-hour PM _{2.5} Std.	10
Days Exceeding the Nat'l 24-hour PM ₁₀ Std.	0
Days Exceeding State 24-hour PM ₁₀ Std.	2

PM_{2.5} Winter Season Totals for 2006-2007

Days Exceeding Nat'l 24-hour PM _{2.5} Std.	20
---	----

3rd Quarter 2007 Agricultural Burn Days

July-Sept. Permissive Burn Days - North	82
July-Sept. No-Burn Days – North	10
July-Sept. Permissive Burn Days – South	82
July-Sept. No-Burn Days – South	10
July-Sept. Permissive Burn Days – Coastal	84
July-Sept. No Burn Days – Coastal	8

Laboratory

Sample Analyzed	1,040
Inter-Laboratory Analyses	3

Technical Library

Titles Indexed/Catalogued	166
Periodicals Received/Routed	438

Source Test

Total Source Tests	239
Pending Source Tests	4
Violation Notices Recommended	18
Contractor Source Tests Reviewed	2,588

Continuous Emissions Monitoring (CEM)

Indicated Excess Emission Report Eval.	50
Monthly CEM Reports Reviewed	144
Indicated Excesses from CEM	22

Ground Level Monitoring (GLM)

July-Sept. Ground Level Monitoring SO ₂ Excess Reports	1
July-Sept. Ground Level Monitoring H ₂ S Excess Reports	1

These facilities have received one or more Notices of Violations
Report period: July 1, 2007 – September 30, 2007

Alameda County

Status Date	Site #	Site Name	City	Regulation Title
7/11/2007	C0054	Bridgeway Service, Inc	Berkeley	Gasoline Dispensing Facilities
7/11/2007	C6992	San Pablo Mini Mart	Berkeley	Gasoline Dispensing Facilities
7/27/2007	B5464	Pixar Animation Studios	Emeryville	Authority to Construct; Permit to Operate
7/02/2007	A0151	Hexion Specialty Chemicals, Inc	Fremont	Episodic Releases From Pressure Relief Devices at Petroleum Refineries & Chemical Plants; Equipment Leaks
8/01/2007	A4134	Irvington Memorial Cemetery	Fremont	Failure to Meet Permit Conditions
9/04/2007	D0470	Hub Valero	Fremont	Gasoline Dispensing Facilities
9/05/2007	B1776	Tomra Pacific, Inc	Fremont	Authority to Construct; Permit to Operate
9/17/2007	P1979	RG Construction	Fremont	Asbestos Demolition, Renovation & Mfg.
8/13/2007	A8399	Chapel of the Chimes Memorial Park	Hayward	Failure to Meet Permit Conditions
8/16/2007	S4189	Louis Trotter	Hayward	Asbestos Demolition, Renovation & Mfg.
7/18/2007	C8260	Grafco Station	Livermore	Permit to Operate
7/18/2007	C8876	Livermore Beacon	Livermore	Gasoline Dispensing Facilities
7/31/2007	B7418	AT&T Mobility	Livermore	NOx & CO from Stationary Internal Combustion Engines
9/05/2007	A2066	Waste Management of Alameda County	Livermore	Major Facility Review (Title V)
7/11/2007	C9280	Lido Auto Care Inc	Newark	Gasoline Dispensing Facilities
8/13/2007	S4108	Coast Litho	Oakland	Authority to Construct; Permit to Operate
8/13/2007	A6390	Evergreen Cemetery	Oakland	Failure to Meet Permit Conditions
8/29/2007	D0437	Fast Gas and Shop	Oakland	Failure to Meet Permit Conditions
7/02/2007	A1371	Dublin San Ramon Services District - Wastewater TP	Pleasanton	Failure to Meet Permit Conditions
8/09/2007	A9511	Central Precast Concrete, Inc	Pleasanton	Failure to Meet Permit Conditions
8/13/2007	B8528	Service Printing Company	San Leandro	Authority to Construct; Permit to Operate
9/04/2007	S3577	Heil Construction	San Leandro	Asbestos Demolition, Renovation & Mfg.
8/01/2007	A1067	Oro Loma Sanitary District	San Lorenzo	Public Nuisance

These facilities have received one or more Notices of Violations
Report period: July 1, 2007 – September 30, 2007
Continued

Contra Costa County

Status Date	Site #	Site Name	City	Regulation Title
7/27/2007	B2855	Henkel Corporation-Aerospace Group	Bay Point	Failure to Meet Permit Conditions Failure to Meet Permit Conditions; Storage of Organic Liquids
7/03/2007	B1961	Tri-Valley Oil & Gas Co	Bethel Island	Open Burning
7/16/2007	S3487	American Civil Constructors	Bethel Island	Authority to Construct Gasoline Dispensing Facilities
7/18/2007	C7695	All Star Gasoline	Concord	Asbestos Demolition, Renovation & Mfg.
9/04/2007	D0530	Willow Pass Gas and Shop	Concord	Authority to Construct; Permit to Operate
9/17/2007	M0669	Janus Corporation	Concord	Permit to Operate; Storage of Organic Liquids
8/06/2007	B8523	Carquinez Rock & Recycle, LTD	Crockett	Gasoline Dispensing Facilities
7/20/2007	S3286	Venoco	Jersey Island	Failure to Meet Permit Conditions
7/18/2007	C8896	Chevron SS #9-5890	Lafayette	Failure to Meet Permit Conditions; Major Facility Review (Title V)
7/02/2007	B0295	Air Products & Chemicals, Inc	Martinez	Solid Waste Disposal Sites
7/25/2007	A7034	Pacific Atlantic Terminals LLC	Martinez	Open Burning; Equipment Leaks; Storage of Organic Liquids
8/06/2007	B3782	Bulldog Gas & Power Inc	Martinez	Public Nuisance; Equipment Leaks
8/13/2007	B2758	Tesoro Refining and Marketing Company	Martinez	Asbestos Demolition, Renovation & Mfg.
9/27/2007	A0011	Shell Martinez Refinery	Martinez	Solid Waste Disposal Sites
9/17/2007	Q2754	Roofener & Son Construction	Pinole	Major Facility Review (Title V)
7/27/2007	A4618	Keller Canyon Landfill Company	Pittsburg	Permit to Operate; Gasoline Dispensing Facilities
9/17/2007	A0031	Dow Chemical Company	Pittsburg	Gasoline Dispensing Facilities
7/18/2007	D0450	Cutting Mini Market (ARCO)	Richmond	Gasoline Dispensing Facilities
8/20/2007	C8605	Sunny Chevron	Richmond	Gasoline Dispensing Facilities
8/29/2007	C8391	ARCO Facility #00428	Richmond	Gasoline Dispensing Facilities
8/29/2007	C7184	Imperial 76 #3713	Richmond	Gasoline Dispensing Facilities
8/22/2007	A0016	ConocoPhillips - San Francisco Refinery	Rodeo	Storage of Organic Liquids
8/22/2007	S4294	Valentine Construction	Walnut Creek	Asbestos Demolition, Renovation & Mfg.

These facilities have received one or more Notices of Violations
Report period: July 1, 2007 – September 30, 2007
Continued

Marin County

Status Date	Site #	Site Name	City	Regulation Title
8/22/2007	S4293	Arntz Builders	Novato	Asbestos Demolition, Renovation & Mfg. Gasoline Dispensing Facilities
7/11/2007	C9921	ELCK, Inc	San Rafael	Hydrogen Sulfide Excess
7/20/2007	A2053	Sausalito-Marín City Sanitary District	Sausalito	

Napa County

Status Date	Site #	Site Name	City	Regulation Title
7/16/2007	A7101	Napa Sanitation District - Soscol	Napa	Failure to Meet Permit Conditions

San Francisco County

Status Date	Site #	Site Name	City	Regulation Title
7/31/2007	C9400	Chevron/Tower Car Wash	San Francisco	Gasoline Dispensing Facilities
7/31/2007	S3830	Tetsuo Group	San Francisco	Asbestos Demolition, Renovation & Mfg.
8/22/2007	S4286	Alex Rabinovich	San Francisco	Asbestos Demolition, Renovation & Mfg.
9/17/2007	C8313	Mission Chevron	San Francisco	Gasoline Dispensing Facilities

San Mateo County

Status Date	Site #	Site Name	City	Regulation Title
7/03/2007	D1198	Lexus of Serramonte - Attn: Ray Chin	Colma	Permit to Operate
9/17/2007	C2809	Silver Gas	Colma	Failure to Meet Permit Conditions
7/26/2007	C9634	Foster City Corp Yard	Foster City	Gasoline Dispensing Facilities
9/04/2007	A7748	Kennedy Auto Body & Paint Shop	Redwood City	Failure to Meet Permit Conditions
9/11/2007	A0051	United Airlines, SF Maintenance Center	San Francisco	Failure to Meet Permit Conditions; Major Facility Review (Title V)
7/18/2007	R7346	Proline Auto Body Service	San Mateo	Motor Vehicle & Mobile Equip Coating Operations
9/04/2007	C9543	Shell Service Station	South San Francisco	Gasoline Dispensing Facilities

These facilities have received one or more Notices of Violations
Report period: July 1, 2007 – September 30, 2007
Continued

Santa Clara County

Status Date	Site #	Site Name	City	Regulation Title
7/18/2007	B2183	Metcalf Energy Center	Coyote	Continuous Emission Monitoring & Recordkeeping Procedures
9/24/2007	S4982	J.N. Abbott Distributor	Gilroy	Gasoline Bulk Terminals & Gasoline Delivery Vehicles
9/11/2007	A5771	J C Cleaners	Milpitas	Perc & Synthetic Solvent Dry Cleaning Operations
7/17/2007	B1696	Maxim Integrated Products, Incorporated	San Jose	Failure to Meet Permit Conditions
7/31/2007	B3289	Los Esteros Critical Energy Facility	San Jose	Continuous Emission Monitoring & Recordkeeping Procedures; Major Facility Review (Title V)
8/20/2007	C4308	Chevron #6027	San Jose	Gasoline Dispensing Facilities
9/18/2007	G7798	Petrotek	San Jose	Authority to Construct
9/20/2007	S4936	Valley Pacific	San Jose	Gasoline Bulk Terminals & Gasoline Delivery Vehicles
9/20/2007	N1032	KAG West, LLC	San Jose	Gasoline Bulk Terminals & Gasoline Delivery Vehicles

Solano County

Status Date	Site #	Site Name	City	Regulation Title
9/20/2007	N3114	Rino	Benicia	Gasoline Bulk Terminals & Gasoline Delivery Vehicles
9/24/2007	S4979	Petro Chemical Valero Refining Company - California	Benicia	Gasoline Bulk Terminals & Gasoline Delivery Vehicles
8/22/2007	B2626	California	Benicia	Major Facility Review (Title V): Equipment Leaks
9/04/2007	C9662	Fast & Easy Mart	Benicia	Gasoline Dispensing Facilities
7/18/2007	P5709	Alpha Petroleum Services Inc	Dixon	Gasoline Dispensing Facilities
8/22/2007	B8563	Concrush Inc	Fairfield	Authority to Construct: Permit to Operate
7/02/2007	P2150	Flatlander Duck Club	Suisun City	Open Burning

These facilities have received one or more Notices of Violations
Report period: July 1, 2007 – September 30, 2007
Continued

Sonoma County

Status Date	Site #	Site Name	City	Regulation Title
7/18/2007	C8355	Kenwood Gas	Kenwood	Gasoline Dispensing Facilities
8/29/2007	C4853	Chevron #0152	Petaluma	Gasoline Dispensing Facilities Authority to Construct; Permit to Operate
7/02/2007	B8522	PDC Properties	Santa Rosa	Gasoline Dispensing Facilities
7/18/2007	D1330	Oakmont Service	Santa Rosa	Gasoline Bulk Terminals & Gasoline Delivery Vehicles
8/09/2007	A0869	Redwood Coast Petroleum	Santa Rosa	Gasoline Dispensing Facilities
7/18/2007	C8795	California Food And Fuel #2	Sonoma	Gasoline Dispensing Facilities
7/18/2007	D0199	EasyServe	Sonoma	Gasoline Dispensing Facilities

**Closed NOV's with Penalties by County
July 2007 – September 2007**

Alameda

Site Name	Site Occurrence	City	Penalty Amount	# of Violations Closed
Associated Aerospace Activities	A3445	San Leandro	\$1,000	1
Automall Parkway Shell	C0783	Fremont	\$300	1
Bridgeway Service, Inc	C0054	Berkeley	\$650	2
Crazy Charlie's Cardlock	C0096	San Leandro	\$500	2
Ghirardelli Chocolate Co	A4784	San Leandro	\$1,000	1
Irvington Memorial Cemetery	A4134	Fremont	\$1,000	1
MacVale Group	Q7536	San Leandro	\$10,000	3
MV Syrena	B0684	Emeryville	\$3,000	1
Olson Steel	B8197	San Leandro	\$1,380	2
R&B Equipment, Inc	R5426	Hayward	\$500	1
Service Printing Company	B8528	San Leandro	\$1,260	2
Tosco Facility #11128	C9353	Livermore	\$500	1
University Vallero	D0524	Berkeley	\$150	1

Total Violations Closed: 19

**Closed NOV's with Penalties by County
July 2007 – September 2007
Continued**

Contra Costa

Site Name	Site Occurrence	City	Penalty Amount	# of Violations Closed
Chevron Products Company	A0010	Richmond	\$42,100	7
ConocoPhillips - San Francisco Refinery	A0016	Rodeo	\$185,500	34
Georgia Pacific Gypsum LLC	A0173	Antioch	\$2,000	1
Imperial 76 #3713	C7184	Richmond	\$500	1
Reich & Berg General Contractors	S0670	Orinda	\$500	1
Safeway Fuel Center #1259	D1121	Antioch	\$500	1
Soil Enterprises, Inc.	R9841	Brentwood	\$500	1
Sparklizing Cleaners	A7448	Danville	\$1,600	3
Sponges Car Wash	C9129	San Ramon	\$250	1
Walnut Creek Shell #136245	C1749	Walnut Creek	\$300	1

Total Violations Closed: 51

Marin

Site Name	Site Occurrence	City	Penalty Amount	# of Violations Closed
Kem's Cleaners	A4293	Novato	\$500	1
Marinwood Chevron	C1952	San Rafael	\$1,500	2
Tim Bennett	S0852	San Rafael	\$500	1
ELCK, Inc	C9921	San Rafael	\$150	1

Total Violations Closed: 5

Closed NOV's with Penalties by County
July 2007 – September 2007
Continued

San Francisco

Site Name	Site Occurrence	City	Penalty Amount	# of Violations Closed
Chevron Station #9-0034	C2699	San Francisco	\$500	1
Matrix Seismic Corporation	Q3355	San Francisco	\$15,000	2
Norton Lilly International	S2025	San Francisco	\$5,000	1

Total Violations Closed: 4

San Mateo

Site Name	Site Occurrence	City	Penalty Amount	# of Violations Closed
Holly Petroleum, Inc	C3165	San Carlos	\$700	1
Scotts Demolition	N6316	San Mateo	\$1,562	2
Lexus of Serramonte - Attn: Ray Chin	D1198	Colma	\$1,391	2

Total Violations Closed: 5

Santa Clara

Site Name	Site Occurrence	City	Penalty Amount	# of Violations Closed
American Custom Marble, Inc	B0547	San Jose	\$860	2
Barefoot Coffee Roasters	B7879	Santa Clara	\$750	2
City of Palo Alto Landfill	A2721	Palo Alto	\$2,000	1
Gatito Cleaners	A6081	Los Gatos	\$650	2
Hanson Permanente Cement	A0017	Cupertino	\$42,000	7

**Closed NOV's with Penalties by County
July 2007 – September 2007
Continued**

Santa Clara (Continued)

Site Name	Site Occurrence	City	Penalty Amount	# of Violations Closed
Merix San Jose	A1163	San Jose	\$1,000	1
Monterey Chevron	C9462	Gilroy	\$750	1
Petrotek	C6907	San Jose	\$456	1
Q Cleaners	B0734	San Jose	\$875	1
Royal Dry Cleaning	B1728	Sunnyvale	\$350	1
Sunnyvale Shell Car Wash	C4501	Sunnyvale	\$850	1
Thao Van Tran	S1211	San Martin	\$500	1
Unocal #3926	C4284	San Jose	\$1,000	2
Unocal #5995	C8003	San Jose	\$1,500	1
USA Petroleum	C5410	Milpitas	\$750	1
Valero	C3722	Palo Alto	\$400	2
Valero Refining Co SS#7760	D0368	San Jose	\$300	1
Valet Organizers Inc	B8238	Campbell	\$1,125	2

Total Violations Closed: 30

**Closed NOV's with Penalties by County
July 2007 – September 2007
Continued**

Solano

Site Name	Site Occurrence	City	Penalty Amount	# of Violations Closed
Flatlander Duck Club	P2150	Suisun City	\$1,000	1
Gas City	C9489	Benicia	\$750	1
Thomas Armstrong	S1372	Fairfield	\$500	1

Total Violations Closed: 3

Sonoma

Site Name	Site Occurrence	City	Penalty Amount	# of Violations Closed
Chevron #0152	C4853	Petaluma	\$150	1
Kenwood Gas	C8355	Kenwood	\$1,000	1
Redwood Coast Petroleum	A0061	Santa Rosa	\$750	1
Flowmaster, Inc	B6490	Santa Rosa	\$1,000	1
Rich's Auto Paint & Body Repair	B2024	Petaluma	\$500	1
Gas Club	C6998	Petaluma	\$1,000	1
Milt Yoshioka	S0259	Petaluma	\$500	1
Santa Rosa Chevron	C9739	Santa Rosa	\$750	1

Total Violations Closed: 8

**Closed NOV's with Penalties by County
July 2007 – September 2007
Continued**

District Wide

Site Name	Site Occurrence	City	Penalty Amount	# of Violations Closed
KAG West, LLC	A4020	West Sacramento	\$3,250	1
KAG West, LLC	B1956	West Sacramento	\$7,000	2
Williams Tank Lines/Mike Stewart	A0064	Stockton	\$3,000	1

Total Violations Closed: 4

ACRONYMS AND TERMINOLOGY

ABAG	Association of Bay Area Governments
AC	Authority to Construct issued to build a facility (permit)
AMBIENT	The surrounding local air
AQI	Air Quality Index
ARB	[California] Air Resources Board
ATCM	Airborne Toxic Control Measure
BAAQMD	Bay Area Air Quality Management District
BACT	Best Available Control Technology
BANKING	Applications to deposit or withdraw emission reduction credits
BAR	[California] Bureau of Automotive Repair
BARCT	Best Available Retrofit Control Technology
BIODIESEL	A fuel or additive for diesel engines that is made from soybean oil or recycled vegetable oils and tallow. B100=100% biodiesel; B20=20% biodiesel blended with 80% conventional diesel
BTU	British Thermal Units (measure of heat output)
CAA	[Federal] Clean Air Act
CAL EPA	California Air Resources Board
CCAA	California Clean Air Act [of 1988]
CCCTA	Contra Costa County Transportation Authority
CEQA	California Environmental Quality Act
CFCs	Chlorofluorocarbons
CMA	Congestion Management Agency
CMAQ	Congestion Management Air Quality [Improvement Program]
CMP	Congestion Management Program
CNG	Compressed Natural Gas
CO	Carbon monoxide
EBTR	Employer-based trip reduction
EJ	Environmental Justice
EIR	Environmental Impact Report
EPA	[United States] Environmental Protection Agency
EV	Electric Vehicle
HC	Hydrocarbons
HOV	High-occupancy vehicle lanes (carpool lanes)
hp	Horsepower
I&M	[Motor Vehicle] Inspection & Maintenance ("Smog Check" program)
ILEV	Inherently Low Emission Vehicle
JPB	[Peninsula Corridor] Joint Powers Board
LAVTA	Livermore-Amador Valley Transit Authority ("Wheels")
LEV	Low Emission Vehicle
LNG	Liquefied Natural Gas
MPG	Miles Per Gallon
MTC	Metropolitan Transportation Commission

NAAQS	National Ambient Air Quality Standards (federal standards)
NO _x	Nitrogen oxides, or oxides of nitrogen
NPOC	Non-Precursor Organic Compounds
NSR	New Source Review
O ₃	Ozone
PM _{2.5}	Particulate matter less than 2.5 microns
PM ₁₀	Particulate matter (dust) less than 10 microns
PM _{>10}	Particulate matter (dust) over 10 microns
POC	Precursor Organic Compounds
pphm	Parts per hundred million
ppm	Parts per million
PUC	Public Utilities Commission
RFG	Reformulated gasoline
ROG	Reactive organic gases (photochemically reactive organic compounds)
RIDES	RIDES for Bay Area Commuters
RTP	Regional Transportation Plan
RVP	Reid vapor pressure (measure of gasoline volatility)
SCAQMD	South Coast [Los Angeles area] Air Quality Management District
SIP	State Implementation Plan (prepared for <i>national</i> air quality standards)
SO ₂	Sulfur Dioxide
TAC	Toxic Air Contaminant
TCM	Transportation Control Measure
TFCA	Transportation Fund for Clean Air [BAAQMD]
TIP	Transportation Improvement Program
TMA	Transportation Management Association
TOS	Traffic Operations System
tpd	tons per day
Ug/m ³	micrograms per cubic meter
ULEV	Ultra low emission vehicle
ULSD	Ultra low sulfur diesel
USC	United States Code
UV	Ultraviolet
VMT	Vehicle miles traveled (usually per <i>day</i> , in a defined area)
VTA	Santa Clara Valley Transportation Authority
ZEV	Zero Emission Vehicle

BAY AREA AIR QUALITY MANAGEMENT DISTRICT
Memorandum

To: Chairperson Mark Ross and Members
of the Board of Directors

From: Jack P. Broadbent
Executive Officer/APCO

Date: November 27, 2007

Re: Consider Adoption of Resolution Endorsing Local Air District Role in AB
32 Implementation of Mandatory Reporting of Greenhouse Gases

RECOMMENDED ACTION:

Adopt resolution endorsing local Air District participation in implementation of the Air Resources Board's (ARB) proposed Regulation for Mandatory Reporting of Greenhouse Gases, by requiring that facilities report greenhouse gas emissions to local districts in an integrated manner with other emissions data and that local districts act as third party verifiers of the data.

BACKGROUND

The California Global Warming Solutions Act (AB 32) requires ARB to adopt a regulation for the mandatory reporting of greenhouse gases (GHG) from large stationary sources by January 1, 2008. During the public process to develop the regulation, District staff participated in meetings with ARB Executive staff to discuss the role of local districts in mandatory reporting and assisted CAPCOA in preparing extensive written comments on the rule that were submitted to ARB. The most recent letter from CAPCOA to ARB's Acting Executive Officer regarding mandatory reporting is attached. ARB staff will submit a proposed Regulation for Mandatory Reporting of Greenhouse Gases to the Board for consideration at ARB's December 6th and 7th, 2007 two day meeting.

DISCUSSION

Air District staff has been working through CAPCOA to encourage that the mandatory reporting regulation provide that stationary sources report GHG emissions to local districts in an integrated manner with criteria and toxics emissions data and that the regulation identify local districts as third party verifiers of the GHG emissions data. Local districts have many years of experience in collecting and verifying emissions data. District staff and CAPCOA believe GHG data collection would be most accurate and efficient if facilities reported GHG emissions to local districts along with criteria and

toxic emissions, subject to ARB guidance and protocols. Through CAPCOA, air districts have been advocating that a regulation for mandatory reporting establish a partnership between ARB and local air districts to implement the most effective and efficient greenhouse gas reporting and verification process to ensure the least cost to the public and the reporting facilities. ARB's proposed regulation does not reflect the District's and CAPCOA's position.

BUDGET CONSIDERATION / FINANCIAL IMPACT:

None.

Respectfully submitted,

Jack P. Broadbent
Executive Officer/APCO

Prepared by: Sigalle Michael
Reviewed by: Henry Hilken

BAY AREA AIR QUALITY MANAGEMENT DISTRICT

RESOLUTION No. 2007-

A Resolution of the Board of Directors of the Bay Area Air Quality Management Urging that Local Air Districts Serve as Collectors and Verifiers of Global Warming Emissions Data under AB 32 and that Pending ARB Regulations Reflect that Role

WHEREAS, in 2006, the California Legislature adopted and the Governor of California signed Assembly Bill 32 (“AB 32”), known as the California Global Warming Solutions Act of 2006;

WHEREAS, AB 32 requires the California Air Resources Board (“ARB”) to adopt by January 1, 2008, regulations for the mandatory reporting of greenhouse gas emissions from greenhouse gas emission sources beginning with the sources or categories of sources that contribute most significantly;

WHEREAS, ARB has prepared, pursuant to the AB 32 mandate, a draft “Regulation for Mandatory Reporting of Greenhouse Gas Emissions” requiring reporting of greenhouse gas emissions from large stationary sources that are responsible for approximately 94% of carbon dioxide emissions from industrial and commercial stationary sources of emissions;

WHEREAS, the draft regulation requires that emissions be reported directly to ARB without submission to the local air district that has regulatory responsibility for the facility;

WHEREAS, the District, and every other local or regional air district, is given primary responsibility for regulating stationary sources within its jurisdiction pursuant to Health & Safety Code §§ 40000;

WHEREAS, the District, like many other local and regional air districts, has been responsible for many years for reporting emissions of ozone precursors and other pollutants to ARB for stationary sources within its jurisdiction;

WHEREAS, as a result of these many years of practical experience in collecting and verifying emissions data, the District and other air pollution control districts have particular expertise well suited to collecting and verifying greenhouse gas emissions data;

WHEREAS, the California Air Pollution Control Officers Association (“CAPCOA”) has, on behalf of local and regional air districts; submitted comments urging ARB to modify its proposed regulation to provide for local and regional air districts to collect and verify greenhouse gas emission data for the stationary sources subject to the regulation;

WHEREAS, the CAPCOA comments are attached to this resolution;

NOW, THEREFORE, BE IT RESOLVED that the Board of Directors of the Bay Area Air Quality Management District does hereby strongly urge ARB to amend its proposed regulation to provide for collection and verification of greenhouse gas emissions data by local and regional air districts;

BE IT FURTHER RESOLVED that the Board of Directors of the Bay Area Air Quality Management District does endorse and support the attached comments submitted to ARB by CAPCOA on behalf of the District and other local and regional air districts.

BE IT FURTHER RESOLVED, that the Board of Directors of the Bay Area Air Quality Management District does hereby authorize the Executive Officer or his designee to undertake such other efforts as are appropriate to convey the District position on this issue.

The foregoing resolution was duly and regularly introduced, passed and adopted at a regular meeting of the Board of Directors of the Bay Area Air Quality Management District on the Motion of Director _____, seconded by Director _____, on the ____ day of _____, 2007 by the following vote of the Board:

AYES:

NOES:

ABSENT:

Mark Ross
Chairperson of the Board of Directors

ATTEST:

Pamela Torliatt
Secretary of the Board of Directors

ATTACHMENT A

CAPCOA LETTER TO ARB

BAY AREA AIR QUALITY MANAGEMENT DISTRICT

Memorandum

To: Chairperson Mark Ross and Members
of the Board of Directors

From: Jack P. Broadbent
Executive Officer/APCO

Date: November 28, 2007

Re: Consider Adoption of Resolution Endorsing Changes to the California Air Resources Board's Proposed Regulations to Reduce Emissions from Diesel Auxiliary Engines on Ocean-Going Vessels while at Berth at a California Port

RECOMMENDED ACTION

Adopt resolution endorsing changes to ARB's proposed shore power regulations.

BACKGROUND

Marine vessels typically generate electricity while in port by running their auxiliary engines and using them as generators. This is the largest source of diesel particulate emissions from Bay Area port operations, and a major public health risk to adjacent communities. For many months, the Air Resources Board (ARB) has been developing a regulation to cut these emissions.

Staff has expressed strong concerns with certain components of ARB's proposed regulation, testifying to our concerns and sending several letters to ARB staff. These letters are attached. Essentially, staff is concerned that the proposed regulation is drafted in a way that will cause no or minimal reduction of health risk until 2014, despite the fact that inexpensive technologies are available today to dramatically cut risk. We have suggested several amendments to the proposed regulation that would both get earlier reductions and cut regulatory compliance costs. These amendments are described in detail in the attached letters. Community groups from West Oakland and elsewhere in the state, the Port of Oakland, PG&E, business interests at the port, environmental groups and others are also supportive of these changes.

BUDGET CONSIDERATION/FINANCIAL IMPACT

No budgetary impacts.

Respectfully submitted,

Jack P. Broadbent
Executive Officer/APCO

Prepared by: Thomas Addison
Reviewed by: Jean Roggenkamp

BAY AREA AIR QUALITY MANAGEMENT DISTRICT

RESOLUTION No. 2007-

A Resolution of the Board of Directors of the Bay Area Air Quality Management Urging ARB to Modify Its Proposed Shore Power Regulation to Provide for Technology-Neutral Means of Compliance and to Allow for Early Compliance

WHEREAS, in 2006, the California Air Resources Board (“ARB”) approved a “Goods Movement Emission Reduction Plan,” which identifies strategies for reducing emissions created from the movement of goods throughout the State;

WHEREAS, the ARB plan identified hotelling emissions, which are emissions from marine vessel diesel auxiliary engines operated while a vessel is at berth, as significant contributors to seaport emissions;

WHEREAS, ARB has prepared proposed regulations entitled “Operational Hour Limits and Other Requirements for Auxiliary Diesel Engines Operated on Ocean-Going Vessels At-Berth in a California Port” that are intended to reduce hotelling emissions;

WHEREAS, the proposed regulations require vessels to turn off their auxiliary engines for most of their stay in port and to rely instead on power provided from the shore, known as “shore power” or “cold ironing;”

WHEREAS, the proposed regulations are constructed in a way that narrowly provides for only one practical means of compliance: the provision of power to vessels from the California electrical grid;

WHEREAS, the proposed regulations would not require significant emission reductions until 2014;

WHEREAS, for many ports, connection to the grid involves construction of transmission lines and other infrastructure at great expense;

WHEREAS, alternative technologies are available sooner and at lower cost than grid power and provide nearly the same emission reduction benefits;

WHEREAS, use of these alternative technologies could produce significant benefits for Bay Area and Southern California port communities;

WHEREAS, District staff have submitted comments to ARB urging ARB to modify its regulatory proposal to set technology-neutral standards that allow for alternative technologies and to allow for early compliance;

NOW, THEREFORE, BE IT RESOLVED that the Board of Directors of the Bay Area Air Quality Management District does hereby strongly urge ARB to amend its proposed regulation to provide for alternative means of compliance and for early compliance;

BE IT FURTHER RESOLVED that the Board of Directors of the Bay Area Air Quality Management District does endorse and support the attached comments submitted to ARB by District staff.

BE IT FURTHER RESOLVED, that the Board of Directors of the Bay Area Air Quality Management District does hereby authorize the Executive Officer or his designee to undertake such other efforts as are appropriate to convey the District position on this issue.

The foregoing resolution was duly and regularly introduced, passed and adopted at a regular meeting of the Board of Directors of the Bay Area Air Quality Management District on the Motion of Director _____, seconded by Director _____, on the ____ day of _____, 2007 by the following vote of the Board:

AYES:

NOES:

ABSENT:

Mark Ross
Chairperson of the Board of Directors

ATTEST:

Pamela Torliatt
Secretary of the Board of Directors

ATTACHMENT A

DISTRICT LETTER TO ARB

BAY AREA AIR QUALITY MANAGEMENT DISTRICT
Memorandum

To: Chairperson Mark Ross
and Members of the Board of Directors

From: Jack P. Broadbent
Executive Officer/APCO

Date: November 26, 2007

Re: Report of the Personnel Committee Meeting of November 14, 2007

RECOMMENDED ACTION:

Approve Committee recommendation of candidates to fill eleven (11) Advisory Council positions. The appointments for nine positions will be for a 2-year term of office beginning January 1, 2008 ending December 31, 2009. The appointments for two positions will be for a 1-year term of office beginning January 1, 2008 ending December 31, 2008.

BACKGROUND:

Pursuant to Section 40261 of the California Health and Safety Code the District is required to maintain an Advisory Council consisting of 20 members. Further, Section 40262 requires that the member categories consist of at least three representatives of public health agencies; at least four representatives of private organizations active in conservation or protection of the environment within the bay district; at least one representative of colleges or universities in the state; and at least one representative of each of the following groups within the bay district: regional park district, park and recreation commissions or equivalent agencies of any city, public mass transportation system, agriculture, industry, community planning, transportation, registered professional engineers, general contractors, architects, and organized labor. To the extent that suitable persons cannot be found for each of the specified categories, council members may be appointed from the general public.

DISCUSSION:

The Personnel Committee met on November 14, 2007 to conduct interviews of candidates to fill specific categories for those Advisory Council positions where nine of the terms will expire on December 31, 2009 and two of the terms would expire on December 31, 2008 due to the 12-year term limit of members to the Advisory Council. Based on the Committee's review of each candidate's background and responses to interview questions, the Personnel Committee recommends approval of candidates that will be included in the oral report given by Director Brown. The recommended selections include ten incumbents and one new candidate.

Director Brown will give an oral report of the meeting which will include the candidates recommended for appointment and their associated category. Attached are the staff reports received by the Committee.

BUDGET CONSIDERATION/FINANCIAL IMPACTS:

None.

Respectfully submitted,

Jack P. Broadbent
Executive Officer/APCO

Prepared by: Mary Romaidis
Approved by: Mary Ann Goodley

BAY AREA AIR QUALITY MANAGEMENT DISTRICT
Memorandum

To: Chair Harold Brown and
Members of the Personnel Committee

From: Jack P. Broadbent
Executive Officer/APCO

Date: October 30, 2007

Re: Conduct Interviews and Consider Recommending Board of Directors' Approval of
Candidates for Appointments to the Air District's Advisory Council

RECOMMENDED ACTION:

Conduct interviews and consider recommending Board of Directors' approval of appointments of candidates to fill eleven (11) Advisory Council positions.

BACKGROUND:

Pursuant to Section 40261 of the California Health and Safety Code the Air District is required to maintain an Advisory Council consisting of 20 members. Further, section 40262 requires that the member categories consist of at least three representatives of public health agencies; at least four representatives of private organizations active in conservation or protection of the environment within the bay district; at least one representative of colleges or universities in the state; and at least one representative of each of the following groups within the bay district: regional park district, park and recreation commissions or equivalent agencies of any city, public mass transportation system, agriculture, industry, community planning, transportation, registered professional engineers, general contractors, architects, and organized labor. To the extent that suitable persons cannot be found for each of the specified categories, council members may be appointed from the general public. The new terms would expire on December 31, 2009, except for the positions held by William Hanna (agriculture) and Fred Glueck (general contractor), who have reached their respective term limits as of the end of next year.

DISCUSSION:

The terms of office for the following categories will expire on December 31, 2007: agriculture, conservation organization (two positions), general contractor, industry, mass public transportation, organized labor, park & recreation, public health agency (two positions), and regional park district. Of the eleven positions with terms expiring, ten incumbents have expressed an interest in re-appointment; the exception being for the position of organized labor. Despite robust recruitment and outreach efforts, only two non-incumbents applied: one for the regional park district position and one for the organized labor position.

Interviews of the two non-incumbent candidates will take place on Wednesday, November 14, 2007 and will begin at 9:40 am. The length of each interview will be approximately fifteen

minutes. The application materials of the two candidates are included for your review. Incumbent candidates (those seeking re-appointment) will not be scheduled for an interview, but information on their attendance and leadership roles are included for your review.

The candidates to be interviewed are listed below, along with the position they seek. The name of the current incumbent is shown in bolded letters; again, the incumbent in the organized labor position, Ed Proctor has not expressed an interest in re-appointment.

Organized Labor

Kendal Oku (**Ed Proctor**)

Park & Recreation

Robert Blau (**Jeffrey Bramlett**)

Finally, an applicant from a previous recruitment to fill the industry position, Stephen Ziman, has expressed an interest in being considered for that position, which is held by Kraig Kurucz currently. The Committee thought highly of Mr. Ziman based on a previous interview, his application materials from the previous recruitment has been included if you would like to consider him. Mr. Ziman did not submit a second application during the time of the current recruitment and for that reason we did not schedule him for an interview.

Respectfully submitted,

Jack P. Broadbent
Executive Officer/APCO

Advisory Council Members Attendance

ADVISORY COUNCIL EXECUTIVE COMMITTEE ATTENDANCE: JANUARY 1 – OCTOBER 1, 2007

MEMBER	4/14	5/9	7/11	8/9	9/12	Assigned/Attended
Blonski	yes	yes	yes	no	yes	5/4
Bramlett	yes	yes	yes	no	no	5/3
Brazil (Sec)	yes	yes	no	yes	no	5/3
Drennen *	//	//	yes	yes	//	2/2
Glueck (Ch)	yes	yes	yes	yes	yes	5/5
Kurucz	yes	yes	yes	yes	no	5/4

* Not a member but attended meeting.

ADVISORY COUNCIL REGULAR MEETING ATTENDANCE: JANUARY 1 – OCTOBER 1, 2007

MEMBER	Annual Treat 1/10	3/14	5/9	7/11	9/12	Assigned/Attended
Blonski	yes	yes	yes	yes	yes	5/5
Bramlett	yes	yes	yes	yes	yes	5/5
Brazil	yes	yes	yes	yes	yes	5/5
Drennen	yes	yes	yes	yes	yes	5/5
Glueck	yes	yes	yes	yes	yes	5/5
Hanna	yes	yes	yes	no	no	5/3
Kim	yes	yes	yes	yes	yes	5/5
Kurucz	yes	yes	yes	yes	yes	5/5
Licavoli – Farnkopf	yes	yes	yes	no	yes	5/4
Zamora	yes	yes	no	yes	no	5/3

Advisory Council Members Attendance

ADVISORY COUNCIL TECHNICAL COMMITTEE MEMBER ATTENDANCE: JANUARY 1 – OCTOBER 1, 2007
--

MEMBER	2/28	4/16	6/11	8/6	10/1	Assigned/Attended
Hanna	no	yes	no	no	yes	5/2
Kurucz	yes	yes	no	yes	yes	5/4

ADVISORY COUNCIL PUBLIC HEALTH COMMITTEE MEMBER ATTENDANCE: JANUARY 1 – OCTOBER 1, 2007
--

MEMBER	2/14	6/13	Assigned/Attended
Bramlet	yes	yes	2/2
Kim	yes	yes	2/2
Licavoli-Farnkopf	no	no	2/0
Zamora	no	yes	2/1

ADVISORY COUNCIL AIR QUALITY PLANNING COMMITTEE MEMBER ATTENDANCE: JANUARY 1 – OCTOBER 1, 2007

MEMBER	2/14	4/11	6/13	Assigned/Attended
Blonski (Ch)	yes	yes	no	3/2
Brazil	no	yes	yes	3/2
Drennen	yes	yes	yes	3/3
Hanna	yes	yes	no	3/2
Glueck *	//	yes	yes	2/2
Kurucz	no	no	no	3/0
Proctor	no	no	no	3/0

* Not a member but attended meeting.

Advisory Council Members Leadership Roles

Name	Advisory Council	Air Quality Planning Cme.	Executive Cme.	Public Health Cme.	Technical Cme.	Applicant Selection Working Group	Board of Directors Ad Hoc Cme. on Woodsmoke
Ken Blonski	1/06 - Present	1/06 – Present Chair (1/07 – Present)	1/07 - Present				
Jeffrey Bramlett	1/04 – Present		1/06 – Present	4/04 – Present Chair (1/06 – Present)			
Harold Brazil	11/02 – Present Secretary (1/07 – Present)	1/03 – Present Chair (4/04 – 12/04)	4/04 – 1/05 Secretary (1/07 – Present)				
Emily Drennen	1/04 – Present	4/04 - Present					
Fred Glueck	9/96 – Present Secretary (1/05 – 12/05) Vice-Chair (1/06 – 12/06) Chair (1/07 – Present)	9/96 – 1/07 Chair (7/99 – 12/01) (5/02 – 12/02)	7/99 – 10/01 7/02 -12/02 Secretary (1/05 -12/05) Vice-Chair (1/06 – 12/06) Chair (1/07 – Present)		9/96 – Present Chair (10/01 – 12/01)		

Advisory Council Members Leadership Roles

Name	Advisory Council	Air Quality Planning Cme.	Executive Cme.	Public Health Cme.	Technical Cme.	Applicant Selection Working Group	Board of Directors Ad Hoc Cme. on Woodsmoke
William Hanna	5/96 – Present Vice-Chair (1/02 – 12/02) Chair (1/03 – 12/03)	1/07 – Present	10/01 – 1/05 Vice-Chair (1/02 – 12/02) Chair (1/03 – 3/04)		9/96 – Present Chair (10/01-12/01)	7/98 – Present Chair (1/05 – Present)	
Janice Kim	2/06 – Present			3/06 - Present			
Kraig Kurucz	2/02 – Present Secretary (1/04 – 12/04) Vice-Chair (1/05 – 12/05) Chair (1/06 – 12/06)	5/02 – Present Chair (1/03 – 4/04)	1/03 – Present Secretary (4/04 – 12/04) Vice-Chair (1/05 – 12/05) Chair (1/06 – 12/06)		1/07 - Present		
Karen Licavoli-Farnkoph	5/96 – Present Secretary (7/98 – 6/99) (8/00 – 2/01) Vice-Chair (7/99 – 8/00) (3/01 – 12/01)		7/97 – 12/01 Secretary (7/98 – 6/99) Vice-Chair (7/99 – 9/01)	7/97 – 9/02 3/06 - Present	9/96 – Present Chair (10/01- 12/01)		7/98 -6/99

Advisory Council Members Leadership Roles

Name	Advisory Council	Air Quality Planning Cme.	Executive Cme.	Public Health Cme.	Technical Cme.	Applicant Selection Working Group	Board of Directors Ad Hoc Cme. on Woodsmoke
Brian Zamora	4/97 – Present Secretary (1/03 – 12/03) Vice-Chair (1/04- 12/04) Chair (1/05 – 1/06)		10/01 – 12/06 Secretary (1/03 – 3/04) Vice-Chair (4/04 – 12/04) Chair (1/05 – 12/05)	7/97 – 1/05 Chair (10/01 – 3/04)		1/05 – 7/05	7/98 – 6/99

BAY AREA AIR QUALITY MANAGEMENT DISTRICT
Memorandum

To: Chairperson, Mark Ross and Members
of the Board of Directors

From: Jack P. Broadbent
Executive Officer/APCO

Date: November 26, 2007

Re: Report of the Climate Protection Committee Meeting of November 15, 2007

RECOMMENDED ACTION

Receive and file.

DISCUSSION

The Climate Protection Committee met on Thursday, November 15, 2007. The Committee received the following reports and presentations:

- 1) Status Report on AB 32 Implementation;
- 2) Status Report on the establishment of an Air District Foundation;
- 3) Discussion and Consideration of a Greenhouse Gas Emission Reduction Fee Schedule; and
- 4) An overview of the Climate Protection Curriculum Pilot Program.

Attached are the staff reports presented in the Climate Protection Committee packet.

Chairperson, Pamela Torliatt will provide an oral report of the meeting.

BUDGET CONSIDERATION/FINANCIAL IMPACTS

None. If adopted, a new fee schedule would help fund qualifying Climate Protection activities in the next fiscal year and thereafter.

Respectfully submitted,

Jack P. Broadbent
Executive Officer/APCO

Prepared by: Mary Romaidis
Approved by: Mary Ann Goodley

BAY AREA AIR QUALITY MANAGEMENT DISTRICT
Memorandum

To: Chairperson Torliatt and Members
of the Climate Protection Committee

From: Jack P. Broadbent
Executive Officer/APCO

Date: November 7, 2007

Re: AB 32 Implementation

RECOMMENDED ACTION:

None. For information only.

BACKGROUND

On September 27, 2006, Governor Schwarzenegger signed AB 32, the Global Warming Solutions Act. The Act caps California's greenhouse gas emissions at 1990 levels by 2020. This legislation represents the first enforceable state-wide program in the U.S. to cap all greenhouse gas emissions from major industries, with penalties for non-compliance. Under AB 32, the California Air Resources Board (ARB) is responsible for monitoring and reducing GHG emissions. Specifically, ARB must:

- Adopt mandatory reporting rules for significant sources of greenhouse gases by January 1, 2008;
- Adopt a plan by January 1, 2009 indicating how emission reductions will be achieved from significant greenhouse gas sources via regulations, market mechanisms and other actions; and
- Adopt a list of discrete, early action measures by July 1, 2007 that can be implemented before January 1, 2010.

DISCUSSION

Staff will present an update on implementation of AB 32, focusing on the work that ARB has done to date, including the development of a list of discrete early action measures, work toward a mandatory reporting strategy, and formulation of a draft scoping plan for meeting the state's 2020 target. Staff will discuss the District's contribution to these distinct processes.

BUDGET CONSIDERATION / FINANCIAL IMPACT:

None.

Respectfully submitted,

Jack P. Broadbent
Executive Officer/APCO

Prepared by: Abby Young
Reviewed by: Henry Hilken

BAY AREA AIR QUALITY MANAGEMENT DISTRICT

Memorandum

To: Chairperson Torliatt and Members
of the Climate Protection Committee

From: Jack P. Broadbent
Executive Officer/APCO

Date: November 8, 2007

Re: Greenhouse Gas Fee Schedule

RECOMMENDED ACTION:

None. For information only.

BACKGROUND

In 2005, the District established a Climate Protection program for the purpose of reducing Greenhouse Gas (GHG) Emissions in the Bay Area. The Climate Protection program focuses on activities that are intended to complement those being established under AB 32, the California Global Warming Solutions Act of 2006. The Climate Protection program involves a wide range of activities, some of which are directed at stationary sources of air pollution over which the District has direct regulatory authority. Program activities related to stationary sources include establishing and maintaining a GHG emissions inventory, conducting studies to identify and evaluate potential GHG emission reduction measures, and developing and implementing rule requirements for the purpose of reducing GHG emissions.

Staff believes that a new fee schedule should be developed for the upcoming fiscal year for the purpose of recovering District costs associated with Climate Protection program activities related to stationary sources.

DISCUSSION

Staff will provide a summary of options under consideration for a new fee schedule applicable to permitted stationary sources of GHGs.

BUDGET CONSIDERATION / FINANCIAL IMPACT:

None at this time. If adopted, a new fee schedule would help fund qualifying Climate Protection activities in the next fiscal year and thereafter.

Respectfully submitted,

Jack P. Broadbent
Executive Officer/APCO

Prepared by: Brian Bateman

BAY AREA AIR QUALITY MANAGEMENT DISTRICT
Memorandum

To: Chairperson Torliatt and Members
of the Climate Protection Committee

From: Jack P. Broadbent
Executive Officer/APCO

Date: November 6, 2007

Re: Climate Protection Curriculum Pilot Program

RECOMMENDED ACTION:

None. For information only.

BACKGROUND

On June 1, 2005, the Air District launched its Climate Protection Program. One focus of the program is youth outreach, including development of a climate protection curriculum for elementary school grade levels.

DISCUSSION

The climate protection curriculum pilot program is a key element of the Air District's effort to provide climate protection educational materials to Bay Area schools. The curriculum, called *Protect Your Climate*, is targeted to 4th and 5th grade levels and is aligned with California educational content standards. The curriculum seeks to teach students about the causes and impacts of climate change and everyday actions that students can take to reduce greenhouse gas emissions. The curriculum contains 16 lessons and addresses air quality, energy, transportation, and waste issues surrounding climate change.

The curriculum is being piloted in thirteen classes in ten schools in five Bay Area counties. The pilot phase is an opportunity to refine the curriculum based on teacher experience and feedback. The goal is a larger scale roll out next school year. Teacher trainings are occurring through November and some teachers have already begun teaching the lessons.

Strategic Energy Innovations, a non-profit organization, developed the curriculum in coordination with District staff. The curriculum was peer reviewed by education professionals and a teacher focus group.

BUDGET CONSIDERATION / FINANCIAL IMPACT:

None. Resources for the pilot curriculum are included in the FY 07/08 Budget.

Respectfully submitted,

Jack P. Broadbent
Executive Officer/APCO

Prepared by: Sigalle Michael
Reviewed by: Henry Hilken

BAY AREA AIR QUALITY MANAGEMENT DISTRICT
Memorandum

To: Chairperson Mark Ross and Members
of the Board of Directors

From: Jack P. Broadbent
Executive Officer/APCO

Date: November 26, 2007

Re: Report of the Executive Committee Meeting of November 19, 2007

RECOMMENDED ACTION

Consider approval to initiate joint legislation with the Metropolitan Transportation Commission regarding a regional fee on gasoline.

BACKGROUND

The Executive Committee met on Monday, November 19, 2007.

The Committee received the following presentations:

Terry Trumbull, Member of the Hearing Board, presented the Hearing Board Quarterly Report for the third quarter of 2007.

The Committee received a report from Fred Glueck, Chairperson of the Advisory Council on activities of the Advisory Council from October 1, 2007 through October 10, 2007.

Staff presented reports and updates on the following items:

- A) Discussion on the future size of the Board of Directors;
- B) Discussion on possible joint legislative action with the Metropolitan Transportation Commission regarding a regional fee on gasoline;
- C) Financial Assistance Programs to small businesses;
- D) Status Report on the Carl Moyer Program audits; and a
- D) Status Report on the Joint Policy Committee.

Attached are the staff reports presented in the Executive Committee packet.

Chairperson Mark Ross will give an oral report of the meeting.

BUDGET CONSIDERATION/FINANCIAL IMPACT

No budgetary impacts.

Respectfully submitted,

Jack P. Broadbent
Executive Officer/APCO

Prepared by: Mary Romaidis
Approved by: Mary Ann Goodley

BAY AREA AIR QUALITY MANAGEMENT DISTRICT
Memorandum

To: Chairperson, Mark Ross and Members
of the Board of Executive Committee

From: Fred Glueck, Chairperson Advisory Council

Date: November 7, 2007

Re: Report of the Advisory Council: October 1 - October 10, 2007

RECOMMENDATIONS:

Receive and file the attached minutes.

DISCUSSION:

Presented below are summaries of the key issues discussed at meetings of the Advisory Council's Standing Committees during the above reporting period.

- A) Technical Committee Meeting of October 1, 2007: The Technical Committee received a presentation from Dr. Marc Fischer on Methane Trends in California.
- B) Air Quality Planning Committee Meeting of October 10, 2007: The Air Quality Planning Committee received presentations on Congestion Pricing from David Burch, Principal Environmental Planner, Air District, Jean Hart, Executive Director, I-680/Sunol Smart Carpool Lane, and Elizabeth Bent, Senior Transportation Planner, San Francisco County Transportation Authority.
- C) Public Health Committee Meeting of October 10, 2007: The Public Health Committee continued discussions on draft recommendations on Indoor Air Quality and Asthma.

The minutes of the above referenced meetings are attached.

Respectfully submitted,

Fred Glueck
Advisory Council Chairperson

Prepared by: Chioma Dimude
Reviewed by: Mary Ann Goodley

Bay Area Air Quality Management District
939 Ellis Street
San Francisco, California 94109

DRAFT MINUTES

Advisory Council Technical Committee
9:00 a.m., Monday, October 1, 2007

- 1. Call to Order – Roll Call.** Chairperson Sam Altshuler, P.E., called the meeting to order at 9:17 a.m. Present: Sam Altshuler, P.E., Chairperson, Louise Bedsworth, Ph.D., Robert Bornstein, Ph.D., William Hanna, John Holtzclaw, Ph.D., (9:34 a.m.), Kraig Kurucz.
- 2. Public Comment Period.** There were no public comments.
- 3. Approval of Minutes of August 6, 2007.** The Committee provided minor revisions to the minutes. After discussion, Dr. Bornstein moved that the approval of the minutes be deferred until Dr. Mark Jacobson reviews that portion of the minutes containing his presentation; seconded by Mr. Kurucz; carried unanimously without objection.
- 4. Presentation on Methane Trends in California:** *Dr. Marc Fischer of the University of California Berkeley gave a presentation to the Committee on Methane Trends in California.*

Chairperson Altshuler introduced Dr. Marc Fischer. Dr. Fischer stated he is a scientist from the Lawrence Berkeley National Laboratory (LBNL) and has been trained in physics and is now working in energy, atmosphere, and environment problems. Dr. Fischer noted he mostly worked in atmospheric science and some amount of bio-geo chemistry (how land surface processes affect atmospheric constituents; in particular green house gases). The Committee members then introduced themselves.

Dr. John Holtzclaw arrived at 9:34 a.m.

Dr. Fischer provided background information and stated that the LBNL is doing a wide-range of research in climate and air quality. The climate related studies are broadening from what has been aerosol and green house gas (GHG) measurements and modeling to include climate modeling at both regional and now global scales. The emphasis in GHG's has focused on the terrestrial exchange from ecosystems to the atmosphere. Human emissions are important, therefore, the LBNL is also moving in that direction. The outline of the presentation is:

- An overview of non-CO₂ GHGs,
- A snapshot of California and Bay Area emissions,
- Multiple methods for estimating emissions to verify emission reductions,
- Initial atmospheric measurement network that is starting this month,
- Conclusions, and
- Directions for further work

Continuing Dr. Fischer reviewed the slide entitled GHGs in Time and Space. The first figure is a map of the earth that shows locations at which the National Ocean and Atmospheric

Administration (NOAA) have been making measurements of GHGs for the past couple of decades. Most of the sites are not in terrestrial areas, but are often in the oceans. The measurements were taken as background monitoring. Interest is now focusing on what the emissions are in the terrestrial and human influence zones, therefore, there is a need for additional measurement points. The main point of the slide is that there is a record for how atmospheric concentrations of GHGs have changed and there are examples globally. Dr. Fischer stated that to understand how changes are occurring one cannot rely solely on models; measurements are essential.

The next plot shows how nitrous oxide (N_2O) has changed both in time (the horizontal axis) and with latitude, and the amount (the vertical axis). Over the period from 1990 to 2000 there has been a steady rise in N_2O and there is a strong latitudinal gradient. Dr. Fischer emphasized that N_2O has a very long lifetime in the atmosphere; the removal mechanisms for it are slow and it is hence fairly well mixed. The gradient from stronger in northern latitudes to weaker in the southern latitudes indicates a northern latitude source.

The second plot shows the same thing for methane. Again, there is a very strong latitudinal gradient where there is much more methane in the northern hemisphere than in the southern. There is a comparatively weaker growth in the last decade. Methane has a much shorter lifetime in the atmosphere and is removed by OH. Methane has a different set of sources from N_2O .

The three slides show what contemporary measurements look like. There is a network of global monitoring stations which are detecting the background methane, CO_2 , and N_2O . The next slide, Overview of non- CO_2 GHG, is a plot that shows the total non- CO_2 , CO_2 , and other forcings of the atmosphere on the globe. The graph shows the change in forcing from pre-industrial times to present. The graph indicates that from pre-industrial times, there have been very significant increases in GHG concentrations. The non- CO_2 gases, which are much stronger absorbers than CO_2 by mass, have increased enough that their combined affect for forcing is comparable to CO_2 . Regarding the ozone on the chart, Dr. Fischer stated that it is an increase in tropospheric ozone from pre-industrial to current times and it is part of the IPCC assessment on climate forcing. This forcing may be a combination of tropospheric and stratospheric ozone. Dr. Fischer reviewed the potency of GHGs and stated that methane is about 20 times as potent as CO_2 , N_2O is about 300 times as potent on a mass weighted basis, and high Global Warming Potential (GWP) gases that include CFCs, HFCs, and SF_6 .

Dr. Fischer discussed the recent trends in global warming gases and where they may head in the future. The top panel of the slide shows the increase in the gases over the 1990 to 2010 period. The blue dots indicate measurements and the yellow and red lines indicate what future increases might look like for CO_2 , methane, N_2O and GWPs. The middle set of plots on the slide are the same gases, but are noted as a per year increase in concentration. At the bottom is the sum and where things are potentially headed. The plot on the bottom right goes out to 2050. How people conduct themselves will have different affects on the forcing. Dr. Fischer stated that there have been very strong increases in both CO_2 and N_2O in the last 15 year period; the future for N_2O depends on agricultural practices; and on fuel combustion. CO_2 is predominately emitted by fossil fuel combustion and a small amount by other industrial processes.

The picture is different for methane. Methane was increasing from 1990 to 2000, but it started to level off after about the year 2000. This indicates that something different is going on with methane. It has not, in the very recent past, been increasing as quickly and there is active research going on to try to understand what is causing the global methane cycle to diverge from a steady growth. In response to a question from Chair Altshuler, Dr. Fischer stated that he felt that, in a statistical sense, the trend is significant. In a long-term perspective of where things are going, it is too early to tell. Because methane has a complicated bio-geo chemistry -- there are many different sources -- it is difficult to say what is causing the trend. Methane is emitted largely by anaerobic decomposition processes. Many people believe that the decreased methane emissions come from thawing tundra which used to be under water. It is now drying and that may be causing this trend. Another thought is that it is possible that the sources of methane coming from human activities has slowed, but it is too soon to determine what the cause is.

Continuing, Dr. Fischer provided information on what can be done in terms of monitoring a GHG if measurements and models are used together. How can one infer the sources and sinks of methane? The plot, entitled Inferring Global CH₄ Sources from 2003 Variances in CH₄, shows the results from a global inversion of atmospheric methane. Using the NOAA flask network data, an inverse model has been run where prior estimates are taken of methane emissions that are combined with a global transport model. This indicates what the surface emission is that is most consistent with the observations. The plot shows a year, per month, of surface methane concentrations models using prior estimates of what methane emissions look like and adjusting that prior estimate to be most consistent with the observations. There is a consistent trend of higher methane in northern latitudes and lower methane in southern latitudes. The plot also shows little spots of high methane showing up at different places in the map. These are regions where the model finds there must have been more methane in order to be consistent with the observations. The peaks are generally in the northern latitude summers.

Dr. Fischer emphasized that by combining actual measurements of concentration, with models of transport and prior estimates of emissions, one can get a better feeling for where the emissions are occurring and how strong they are. There is now a problem with dealing with emissions on a national, state, regional, or county-level scale. The argument is to move down and scale from global to these smaller scales using the same kind of techniques, but with improved measurement and modeling methods.

Chair Altshuler observed that, from an energy perspective, the plot shows that West Virginia and the east coast might be the "hot spots" in the United States. These are areas in which coal is used. In California and the west coast the tendency is the use of natural gas. Chair Altshuler questioned if there a correlation. Dr. Fischer stated that this plot is not emissions, but surface level concentrations. Western North America uses a lot of natural gas, but there is a lot of ocean air diluting that source to the atmosphere from natural gas use. In this model, it is being diluted away; the model also may underestimate how much emission is occurring at the Western boundary. There is only one station at Trinidad Head, which is north of the Bay Area and is a "clean" environment to judge what the methane concentrations of the West Coast should look like.

Dr. Fischer stated that measurements of methane gas will be put up at Sutro Tower in San Francisco for a more localized measurement. Dr. Holtzclaw noted that the largest

concentration, and possibly source, tends to be in Russia, but there are no monitors in that area. Therefore, there is more speculation in that area as to the source of emissions. Dr. Fischer stated that this information is a combination of a model that is making an estimate of where the emissions are based on where they believe wetlands occur. The hot spot in northern-central Asia is, in fact, due to assumed methane emission from wetlands.

The next plot shows the total California GHG emission trends. This is total emissions converted into CO₂ equivalent units, million metric tons (MMT) of CO₂. Data was taken from the California Energy Commission's (CEC) GHG inventory that was compiled in 2006. The vertical scale has been truncated and it only shows from 300 up to about 550 MMTs. CO₂ is the largest forcing estimated from inventories for California and it is also the largest source of variation in the trend. CO₂ is where the need is to start controlling GHG emission. The non-CO₂ GHGs constitute about 10% of the total emission. Presently the CO₂ from California is much bigger than the annual increased forcing due to the other gases.

Dr. Fischer made the argument that while CO₂ must be controlled first, the non-CO₂ GHGs have benefits in terms of controls that are not just climate related. Methane is emitted in California by landfills and by agricultural sources, principally animal live stock. If the methane emitted from these sources could be captured, it could be used for energy, rather than just mitigating climate warming by burning the methane to CO₂, which is done currently.

For 2004, Dr. Fischer showed what the non-CO₂ GHG emissions are for a number of different source categories. There are a number of different sources of both methane, a couple of sources for N₂O and the high GWP gases that are all together. All of the estimates are uncertain, it is not known for better than 30% how big any of these sources are. One thing that can be done to reduce the uncertainty is to try to use another method of measuring and inferring what the emission had to have been.

The plot entitled Bay Area GHG Balance was shown next. Dr. Fischer acknowledged that the information for the chart was assembled by the Air District. It shows that the estimated non-CO₂ GHG emissions for the Bay Area are approximately 10% of the total. This is similar to the estimates that the CEC has for the breakdown for the state. The message is that increased transportation fuel efficiency should be a first priority if GHG forcing emissions are to be controlled. CO₂ from transportation is the dominant source. A second message is that rural counties are likely to be different from the average picture. Rural counties will have less transportation and a greater portion of emissions from agricultural GHG emissions. The individual inventory-based emission estimates are likely uncertain at a 20-40% level. Alternatively, looking from the top down, using atmospheric measurements, there is another way of saying how much emission is coming from California.

There was a brief discussion on what changes might occur 20 years from now regarding the rise in GHG emissions and different scenarios on curtailing GHGs. Dr. Fischer stated that if the climate changes enough, there are potential "positive" feedbacks to climate. An example is the large stores of methane in methane ice shelves in very northern latitudes in marine boundary environments called methane clathrates. If it destabilizes and the methane boils off into the atmosphere it could cause a large and rapid "positive" increase in forcing.

Dr. Fischer discussed what is being done to try to estimate the non-CO₂ GHG emissions. The essential ingredients for an independent verification method for GHG emissions include:

- Start with a priori inventory estimates of GHG emissions of interest. Dr. Fischer emphasized that one needs to have the best number and an estimate of how certain that number is.
- A model for atmospheric transport and surface influence “footprints.” If a measurement is made at a given point in space and time, how much measured at that point came from what region in the Bay Area.
- A way to combine the emissions and atmospheric influence functions -- what should the “signals” measured in the atmosphere look like.
- Quantitative GHG boundary conditions for what comes from outside of California. What is measured in California is not just coming from California.
- Continuous long-term measurements of the GHG of interest and other species that one can help associate specific sources with the measurements made.
- A statistical framework in order to evaluate whether emission inventories one started with are consistent with the measures; or if the emission inventories need to be revised to be more consistent with the measurements.

The next slide, entitled *A priori* CH₄ Emission Inventories, shows an average year in the year 2004 of methane emissions by county in California. The counties far from urban areas have low emissions and the counties either in, or surrounding, the urban regions have higher emissions. The sources of emissions included landfills, animal agriculture, natural gas distribution and use, wetlands, and crop agriculture.

Attributing a given source to an atmospheric measurement can be done by using isotopic signatures. Natural gas and gasoline have different C13 isotopes. Most carbon is carbon 12; there is a small fraction that is carbon 13. If the carbon 13 content is measured, it can be determined if the CO₂ is more likely gasoline than natural gas. Similarly, carbon 14 is an unstable isotope of radio carbon that is produced in small quantities in the upper atmosphere. Carbon 14 only has about a 5,700 year lifetime and fossil fuels, which are millions of years old, have lost all of their carbon 14. Work is being done to distinguish methane emissions based on these isotopes of methane.

Carbon monoxide and VOCs also help determine what an air mass might have had as a source. The radon content of atmospheric air samples has started to be used to estimate atmospheric mixing. The map on the slide shows an estimate of how much radon is emitted from soils to the atmosphere as a function of space in the Western United States. Radon has a short half life of 3.8 days, therefore if radon is measured in the atmosphere it had to have come from some soil surface in the recent past. Radon will be used as a tracer for how much the air is in contact with the surface. When soils are dry, radon diffuses out of the soil readily; when soils are wet, it is trapped.

Dr. Fischer discussed the measurement sites that are being set up in an effort to measure GHG on a fine spatial scale that can determine regional emissions. The project is being funded by the California Energy Commission and will look at non-CO₂ GHGs. One of the two sites chosen for the first part of the study is Sutro Tower in San Francisco. Measurement tubes will be installed on Sutro Tower and air will be collected in flasks at the bottom of the

Tower. The second site is the KCRA Tower in Walnut Grove, where the tubes have already been installed.

The type of instruments being used on the Towers was reviewed. There will be a flask sampling system and samples will be collected twice a day. NOAA will analyze the samples with very precise and accurate instruments to produce methane, CO₂, nitrous oxide, CO concentrations, SF₆, halo carbons, and, hopefully, ¹³CO₂, ¹³CH₄, and CDH. The samples will provide information on what the GHG concentrations are above an urban environment influenced by marine processes (at Sutro) and samples from the central valley (KCRA).

In addition, at the KCRA Tower, there will be a continuous methane and CO₂ analyzer that will make a measurement every three minutes. There will also be a CO₂/CO rack system and a radon monitor. In collaboration with the LLNL, flasks full of air will be collected which will be measured to determine the radiocarbon content of the CO₂ in that air.

Dr. Fischer next showed a plot that is a simulation of fossil fuel CO₂ in the surface layer atmosphere as a function of time for the month of July 2005. The simulation was done using an emission inventory constructed by the Environmental Protection Agency (EPA) for nitrogen oxide emission and scaled to CO₂ with a constant factor. The model is the NCAR-MM5 model run at 10 km. resolution. It shows that, with respect to computer modeling, that the emission inventories can be taken and propagated into the atmosphere and it can be determined what the concentrations of fossil fuel CO₂ should look like as a function of time. The same thing can be done for methane with all the sources mentioned and a picture can be generated on what concentrations should look like at different places from different sources. Work will be done to make a better representation for transport. Two main sources of CO₂ in California are the Los Angeles Basin and the San Francisco Bay Area.

A footprint model is used to attribute emissions from a given location to a measurement point later. The footprint model works by releasing imaginary particles at the place the measurement is made and running them backward in time following the air velocity and turbulence characteristics back to the location on the land surface that the sources are present. Dr. Fischer presented a slide showing the areas that are affecting a measurement at Sutro Tower at 230 meters for July 2004. The simulation is being done every three hours of the month of July using a particular implementation of a transport model called the BRAMS model. The goal is for highly resolved and very accurate meteorology for this purpose. If the meteorology is wrong, there will be an incorrect inference about where the emissions are coming from and how strong they are. Dr. Fischer noted that the plume changed with time and that sometimes the plume is just air coming off ocean, other times it is air that is in contact with California.

Continuing, Dr. Fischer presented a plot combining the emission inventories previously discussed and the footprint function. The purpose is to determine what the concentrations of methane at Sutro Tower will look like as a function of time for the month of July 2004 from the different sources (landfills, livestock, wetlands, natural gas, and radon). There are very low concentrations, with a spike every so often. The reason for this is that most of the time the air coming to Sutro Tower comes off the ocean and contains only background methane. The spikes are due to the footprint having some contact with a land surface where there are emissions from the sources as listed above. The KCRA plot was discussed and it shows a diurnal cycle each day. The KCRA Tower is surrounded by land surface influences and

constantly reads methane from relatively local and regional sources. If the predicted signals are taken and are compared with the signal of estimated radon, for the Sutro Tower, many of the sources have a tight correlation.

In summary, Dr. Fischer stated that California and Bay Area GHG emissions are dominated by CO₂, therefore reductions should start there. Non-CO₂ GHG (methane, N₂O, CH₄, and high GWP) emissions are significant (at the level of 10% of the total emissions currently) and uncertain and beneficial opportunities exist for reduction. Long-term measurements provide an independent and complementary method to verify reductions. The inventories should not be relied on solely, although they need to be done first, but there has to be a way to check them. The initial numerical modeling suggests that the GHG signals are clearly going to be measurable and may provide a strong handle on the emissions. It remains to be seen how much the uncertainties can be reduced. The inverse statistical model will provide a quantitative method to improve the inventories; in particular, assuming an accurate representation of the errors going into the inverse problem can be obtained, there should be an objective way of understanding the errors and the uncertainties in the final emissions. Multiple measurement of multiple tracers are required to more uniquely attribute measured concentrations to a given source estimates. Nested high resolution (approximately 1 kilometer) atmospheric transport models are essential for locations with complicated terrain.

Chair Altshuler recommended that the rate of change be noted in Dr. Fischer's summary (at the second bullet) and stated that while CO₂ is still the largest "piece of the pie," it is also rising. Dr. Bornstein provided additional suggestions, which have been incorporated into the minutes. Chair Altshuler suggested that the Summary page be divided into two pages where the first three bullets would be on the first page as a policy perspective and the last four bullets are more the science and how to get there.

Saffet Tanrikulu, Research & Modeling Manager, stated that CO and CO₂ are already included in the District's modeling exercise. Methane is not explicit so the District can look at CO and CO₂ concentrations through the simulation. Dr. Bornstein noted that the CO₂ estimates were for more traditional air quality and may not capture other sources as discussed at today's meeting. Dr. Tanrikulu stated that Dr. Bornstein's statement is true, partly because CO₂ is not a strong precursor for ozone and the focus has been on ozone and PM.

Dr. Fischer commented that the District's modeling could include CO₂ from fossil fuel combustion. It will be increasingly important and it is currently an area of active research to understand the uptake of CO₂ and the release of CO₂ from the terrestrial biosphere; that is plants growing and dead organic matter decaying.

Mr. Altshuler stated that there is some radon in natural gas and that the amounts differ depending on where the gas comes from. There is more radon in California gas and Dr. Fischer noted that if the gas travels, even for a couple of days, to get to California than some radon will be lost to natural decay.

Dr. Fischer stated that if a lot of fuels are shifted to a plant based source; radio carbon cannot be used as a unique tracer of that fuel combustion.

Dr. Fischer highlighted the further work to be done and stated that the first step would be the concentration measurements of GHGs at Sutro and Walnut Grove Towers, which information

will be available later in the year. Another item being worked on is an upgrade of the meteorological modeling in collaboration with other groups to include the nested grids. Developing and testing high resolution meteorological fields for tower sites using MM5 and Weather Research Forecast (WRF) model outputs. Further work also includes incorporating the additional-tracer and species for source attribution analysis. Finally, to initiate inverse model-data-synthesis estimates of regional GHG emissions and uncertainties.

Chair Altshuler thanked Dr. Fischer for his presentation.

5. Discussion and Summary of Issues Related to Global Warming: *Committee members discussed issues related to energy and global warming.*

Chair Altshuler initiated the discussion and asked for suggestions on key points the Committee could discuss in the coming year. Chair Altshuler stated that Dr. Fischer talked about the bookshelves and the non-CO₂ gases. He noted that there has been a strong message regarding ethanol not being the “cure all” for climate change. At the September 21st Climate All Stars conference it was recommended that everyone stop burning coal.

Suggestions from the Committee included the following:

- Focusing on policy levers that the Air District may or may not have control over.
- Trying to narrow it down to what does it mean for what the District is doing and how does it relate to the Air District’s air quality planning efforts.
- A summary of the technical information the Committee has heard is useful in terms of the state of the science, but it should be narrowed down to what is the Air District’s day-to-day practice.

Henry Hilken, Director of Planning, Rules and Research Division, interjected that in terms of the Air District’s Climate Protection Program, one of the key points is harmonizing everything the District is doing already – the traditional air quality programs with climate protection. Identifying areas where the District’s air quality monitoring could incorporate some impacts of climate change. On the policy side, it would be what the District does about it and looking at co-benefits of mitigation strategies.

Additional discussion items included:

- Possible discussion on how the state incentivizes energy or fuel use – this would give the Committee a few more levers to try to put into play if the Committee does not mind making recommendations that are not strictly the scope or charter of the Air District.
- Things that would incentivize different fuel choices, wind energy or efficiency moves that could be made at utilities or at the user end. This one done on the smog check program.
- The Committee could be broad in that respect.
- Some of the things that work just for the Bay Area are things that need to be done on a state-wide level and might not be able to be done in the Bay Area without legislative interaction.

- The last 3 to 4 speakers have provided a lot of technical information and a summary of their presentations would be useful.
- One of the findings to be able to make is the sources that the District has concentrated on in order to address ozone
- The appropriate sources for GHGs as far as the Bay Area is concerned.
- Agricultural emissions and emissions from combustion sources
- Looking at the sources of methane that the Air District might have some influence over; landfill is one, other methane from natural gas methane.
- Looking at an action that will cause an unintended consequence and looking at actions that have cumulative good consequences.
- Energy conservation solving a lot of pollution problems in addition to a lot of climate change issues.
- Black carbon.
- Focus on CO₂ as the gas that should have the most concern and continue supporting research to make sure that that is the most effective way.
- MTBE-type issues should be flagged. Ethanol is getting close to that; in particular the health effects.

Dr. Bornstein recommended that the Committee members prepare a list in advance and bring it to the next meeting. The final list could be divided into recommendations that would go to the other Committees.

- 6. Committee Member Comments/Other Business.** Dr. Holtzclaw thanked Chair Altshuler for an interesting meeting and for keeping the Committee on track this year.
- 7. Time and Place of Next Meeting.** 9:00 a.m., Monday, December 10, 2007, 939 Ellis Street, San Francisco, CA 94109.
- 8. Adjournment.** 11:40 a.m.

Mary Romaidis
Clerk of the Boards

Bay Area Air Quality Management District
939 Ellis Street
San Francisco, California 94109

DRAFT MINUTES

Air Quality Planning Committee
9:30 a.m., Wednesday, October 10, 2007

1. **Call to Order:** Chairperson Ken Blonski called the meeting to order at 9:35 a.m.

Roll Call: Ken Blonski, Chairperson, Harold Brazil, Irvin Dawid, Emily Drennen, William Hanna (9:55 a.m.), John Holtzclaw, Ph.D., Robert Huang, Ph.D.

Absent: Kraig Kurucz, Ed Proctor.

2. **Public Comment Period.** Norman Rolfe, S.F. Tomorrow, 2233 Larkin St., #4, San Francisco, CA, 94109, wanted to draw everyone's attention to the S.F. Chronicle Newspaper Section B-9 with sad news of the obituary of Jean Cordum, activist and major campaigner in the S.F. Freeway Revolt. Ms. Cordum was one of the key figures of the freeway revolts over the past years, and one of the founders of San Francisco Tomorrow. Mr. Rolfe, urged everyone to read Ms. Cordum's obituary.
3. **Approval of Minutes of June 13, 2007:** Dr. Holtzclaw moved approval of the minutes; seconded by Chair Blonski. Chair Blonski called for approval and the draft minutes were approved unanimously.
4. **Bay Area Congestion Pricing Presentation by:** *Mr. David Burch provided introductions and involvement of Air District to date with the topic of congestion pricing.*

Mr. Burch briefed the Committee on a couple of initiatives in the Bay Area regarding congesting pricing. In addition, Mr. Burch provided history and context for why the Air District is interested in pricing measures and the potential implications for air quality.

Mr. Hanna arrived at 9:55 a.m.

Mr. Burch stated, congestion pricing is one of several possible pricing measures that are sometimes referred to as market based measures. From the standpoint of air quality, market based measures are basically a type of transportation control measure that can help to reduce to emissions, by relying on market based pricing mechanisms to reduce driving and reduce emissions. Market based measures can include increased gas taxes or user fees that could involve roadway pricing; which congestion pricing is one of the options, which could include bridge tolls, high occupancy toll lanes, and it also involves parking fees or vehicle registration fees that are based upon the amount of vehicle emissions. So there is a wide range of things that fit under the rule brick of market based measures. There has been an impressive gain in improving air quality from the technology side, such as tailpipe emissions, cleaner fuels, etc. on a per vehicle, per mile basis. The Air District has made great progress for improving air quality. However, that progress has been eroded to a certain extent by the

continual growth in the size of vehicle fleet, and the amount that those are driven, which is called Vehicle Miles Traveled (VMT). VMT is projected to continually increase and that is going to continue to offset some of our progress. Many economists and planners argue that a big part of the reason for the rapid growth in VMT is that we do not price our roadway systems in a way that would encourage more efficient use.

At this point in time, it is neither economically nor environmentally feasible to expand the road system enough to satisfy unconstrained demand. So we need to figure out how to use the existing system more efficiently and pricing may be a key part of that solution. Market based measures and congestion pricing are of great interest, because they provide a means to tackle both our transportation and our air quality challenges. As market based measures have been advocated by economists and planners for at least 20 years now; and they have been included in all of the clean air plans that have been adopted in the bay area since the original plan in 1991. Back in early 1992, the Air District actually hosted a major conference on Market Based Measures. At least 15 years ago, there was already considerable interest in this area. In the current Clean Air Plan, the 2005 Ozone Strategy, PCM 18 calls for the Metropolitan Transportation Commission (MTC) and the Air District to pursue pricing measures including congestion pricing, higher bridge tolls, gas tax increases and parking fees.

The progress towards implementing market based measures in the real world has been uneven, especially here in the U.S. There have been concerns about technological feasibility in terms of how the tolls are collected; equity, the potential impacts on low income drivers and most importantly, political acceptability. Today, the technical issues have been largely resolved, equity can be addressed and public opinion may be gradually warming to pricing measures. There are a lot of real world examples of pricing schemes today. As you may be aware, there are zones or cordoned pricing schemes that have been implemented in Singapore, London and Stockholm, as they have been successful and have had impressive results. There have been High Occupancy Toll Lanes (HOT) where individual, private, single occupant drivers can buy into the carpool lane. This has been in Southern California since the 1990s in Houston and now they are coming online in places like Minneapolis as well.

There are two key ways that market based measures can help improve air quality. By increasing the price of vehicle ownership or vehicle operation costs, we can reduce demand and reduce driving, secondly, we can take the revenues that are generated from those mechanisms and use them to promote and fund alternative modes of transportation. In the case of congestion pricing, there is one more benefit; which is that if you have a congested facility, and low speeds, emissions tend to be higher in stop and go driving to the extent that we can relieve the congestion, and potentially reduce the emissions in those corridors. That said, it is not necessarily a foregone conclusion that congestion pricing would be good for air quality, a lot of it is going to depend on the particulars of how you go about implementing that.

A couple of cautionary notes is 1) new lanes added and we increase capacity, that certainly has a potential to generate and induce demand, new trips and even if you do not necessarily increase capacity by building a new lane; 2) if moved, some of the cars that are in the mixed flow lanes that may be congested into a HOV lane and you make the traffic flow better in those mixed flow lanes.

It is possible that there could be some induced demand if the trip becomes quicker, than someone taking the bus that may decide to switch over to driving. It is also important to point out that there is a speed curve related to emissions and emissions tend to be highest at slow speeds and tend to be best at the range of 35-50 miles per hour. As speeds increase above 50 mph, the emissions are both criteria pollutants and CO₂ begin to increase again; as you want to avoid the slow speed, but do not want to encourage the real high speed.

Last precautionary note, is if HOV lanes and carpool lanes were to become more congested because of single occupant vehicles going into those lanes, that could erode the travel time advantage of carpools, vanpools and buses; and that is not something we want to happen. This is largely a management issue that could be addressed, but it is something that should be borne in mind. Bottom line is that we are closer than ever to seeing tangible congestion pricing projects here in the bay area. State legislation has authorized four corridors as HOT lane demonstrations here in the bay area, which are all scheduled to come online by the year 2015. This includes I-680 project the Sunol Grade, between Alameda and Santa Clara counties. Also, I-580 eastbound in the Tri-Valley area which includes Pleasanton and Livermore and down in Santa Clara county both highway 101 and highway 85 are also slated for HOT lane demonstration projects.

In addition to those corridor specific projects, MTC is currently working on a regional HOT lane network study, and are potentially looking at a very robust, comprehensive system, that would eventually convert all HOV lanes in the region into HOT lanes and expand network and serve as a mechanism for an enhanced regional express bus network. Another thing happening at the regional level right now is that MTC is updating the Regional Transportation Plan. Various performance targets in terms of trying to reduce congestion, emissions and VMT. They are evaluating different packages of capital projects as well as pricing measures and land use measures to see what would help to get them towards those targets, and the preliminary analysis show that the pricing measures would be the most effective of those options, in terms of trying to meet targets related to reducing emissions and congestion.

Mr. Burch noted that the Committee would hear from Jean Hart, regarding the project for the HOT lanes on I-680 and then from Elizabeth Bent, from the San Francisco County Transportation Authority, which she will talk about Doyle Drive.

Mr. Burch concluded his presentation, stating that Air District staff is participating on a technical review committee for these types of efforts with both MTC and San Francisco County Transportation Authority. The Air District will work to ensure that as we go forward, these types of projects and initiatives are implemented in a way that will provide the greatest benefit to air quality.

Discussion ensued among the Committee, with regard to HOV and HOT lane in the Bay Area.

Jean Hart, Executive Director, I-680/Sunol Smart Carpool Lane Joint Powers Authority, presented to the Committee, the I-680 HOT Lane Update.

Ms. Hart indicated that the Joint Powers Authority encompasses members of the Alameda County Congestion Management Agency, the Alameda County Transportation and Improvement Authority in Santa Clara County, and the Valley Transportation Authority. It has five members who are elected to the respective agency boards and then serve on the Joint Powers Authority.

Ms. Hart stated that she appreciated the opportunity to speak about the I-680 HOT Lane Project and that as a part of the presentation, will talk about the polling that was conducted by the Joint Powers Authority in response, and have conducted focus groups as well, as well as public opinion polls. Some of these polls were general and some by people who use the corridor.

Ms. Hart indicated that the I-680 project will go under construction next year and will be the first HOT lane project in the bay area. San Francisco is very aggressive in their approach, but it appears now in looking at the schedule, that the I-680 project will be first. It is a 14-mile stretch that includes both Alameda County and Santa Clara County and that is the reason that VTA is participating on the Joint Powers Authority. The 14 miles begins near the city of Pleasanton near route 84 on I-680, and terminates near highway 237 in the city of Milpitas, which is in Santa Clara County. Eleven miles are within Alameda County and three miles are in Santa Clara County.

The HOT lane will work first and foremost and will be free to carpoolers and other normal HOV users. Vehicles that have the ability to use hybrid vehicles in the HOV lane will also be able to use the HOT lane without a fee, just as carpoolers will be to use the lane without a fee. Solo drivers can choose to pay to use the carpool lane, as there will not be any toll booths, but will be able to use your Fas Trak transponder that is currently used on the bay area bridges.

Conceptionally, the tolls will increase when the traffic on the non-toll lane is more congested, so the price of the facility is tied in to the level of congestion not only on HOT lanes, but on the mixed flow lanes. No one else in the United States has tried this approach, and will truly provide the price of what the benefit is that the solo driver will be paying by using the HOV lane. There are currently two HOT lanes in Southern California and there is one on I-15 in San Diego, one on SR-91 that is in Orange County and there is a HOT lane that is operated in Minneapolis that is called the Min Pass. Those are current HOT lanes and the Joint Transportation Authority has information from them as well as polling. In general, the people who will be using it are parents who have children at day care centers, workers that have deadlines, contractors and anyone that needs to be somewhere at a specific time needs a reliable commute and carpoolers and transit vehicle users.

The poll indicates that the general populous in Alameda County, Contra Costa County and San Joaquin County and polls were also conducted for people who are quarter users of the I-580 and I-680 corridor, so there has been feedback from the general population of the area as well as corridor users. Generally, commuters who use the current facilities support the concept about 2 to 1 and the statistics are 64% to 33%.

Most of the commuters say that they would use the HOT lane, but all have said that they will not use it every single day. There were some before and after polling about the concept of HOT lanes; how often would you use it, and the response was that people stated that they would use it all the time. Then when it was mentioned that there was going to be a charge for this based on the levels of congestion and then the response was that we would use it when we need to get some place in a hurry, at a fixed time. So then it dropped to about 30% to 40% who would use it regularly and that would be three days a week.

How we propose to operate the HOT lane is that it will operate 24-hours a day, 7-days a week. The HOV lanes would also operate that way, and is considered to be different than any of the current carpool lanes in the bay area, who have limited operation. The proposal is that both the HOV as well as HOT lanes operate 24/7. The toll for solo drivers ranges from a minimum of \$1 and that would be for the total trip to its most congested around \$7-\$9 at peak of the peak.

There would no toll booths, as there are limited entry and exit points. The solo drivers would decide each trip based on both one their needs; as well as the current toll whether or not to use the facility. Also, there would be enhanced enforcement from the California Highway Patrol. The Joint Powers Authority has been working with San Diego to develop the technological approach to enforcement, but we are not far enough along yet, to employ that.

Ms. Hart had the Committee come down to view the illustration of the project. The facility plan is north/south and shows Pleasanton, Fremont and Milpitas. At present, there is a HOV lane on I-680 corridor, so that lane would be converted from a HOV to a HOT lane. The facility would start where the current HOV lane starts. Carpoolers would be able to enter this lane as well as SOV users. A sign would indicate that the HOT lane is ahead, and as well as display the cost of the HOT lane. There will be two exit points. The first one would be located at the Auto Mall which would indicate the price for example to Mission which is a major connector to I-880, so then you will see a price says to Mission Boulevard, showing the driver the cost. Drivers will be able to make a decision whether or not it is worth it to pay whatever that cost it. The driver would be able to decide if they are in the mixed flow lane, they would choose not to enter into the HOT lane. If they decide that they are willing to pay that price, they would enter into the HOT lane and then they would be required to stay in the HOT lane as well as HOV users until the exit after Auto Mall, Washington.

The cost is conducted electronically via the Fas Trak reader with an antenna, just like when going through the existing toll booths on the Bay Bridges and the antenna reads the transponder and the price that is one the dynamic pricing. At any point in time there could be three different prices depending on how you drive. The formula that will be used to determine the price is based on the congestion in the mixed flow lanes is perfectly rational and makes a lot of sense. Currently the facilities only monitor the congestion that is in the HOT lanes, so that you can guarantee a certain speed that is only based on the congestion there, not on the congestion in the mixed flow lanes; so this way you are only paying for what the benefit in the amount of time that you are saving, which is considered to be a true user's fee as well.

Mr. Brazil inquired about the pricing in San Diego. Ms. Hart's response's was that it is priced first with the HOT lane only. I-15 express is currently doing congestion pricing on the lane itself. Ms. Hart indicated that the price does go up and down, but based on the congestion in I-15.

Signage will alert the drivers that there will be a carpool and Fas Trak lane ahead. The text is currently being worked on, as the sign should be informative and not confusing. With additional signs showing the cost to exit at the various points.

The timeline of the project is estimated as follows:

- Utility relocation – 2007;
- Final design – 2008;
- Construction begins – 2008; and
- HOT Lane opens - 2010

The costs and revenues are estimated as follows:

- Construction Costs - \$20.9M;
- Electronic Tool System Costs – \$11.4M;
- Other Costs - \$8.1M;
- Total Project Costs - \$40.4M; and
- Projected Revenue - \$5M/per year

Ms. Hart clarified that at this time, there is only a southbound HOV lane; and there is no northbound HOV lane. Funding from the southbound will help pay for the northbound and the northbound will be built as an HOV/HOT lane. This will provide funding to complete that system.

The benefits are that this is a new choice, to travel faster than they would otherwise. It will save time, one would be able to use it when need to, as you are not required to use it everyday. There are no changes in the HOV lane, except for the limited ingress and egress, so that is a change for the carpoolers. Some cities have shown that the limited access does improve safety and the revenue that is generated by the corridor would not be otherwise available without this type of a facility.

Ms. Hart concluded her presentation and asked if the Committee had any questions. Chairperson Blonski opened it to the Committee for questions.

Dr. Holtzclaw thanked Ms. Hart for the presentation, and noted that HOV lanes and HOT lanes can be quite beneficial. Dr. Holtzclaw questioned the third item that the revenue would be used for building I-680 Northbound HOV lanes; wanted to know if there would be any capacity increases as a part of that with the widening of lanes, etc. Ms. Hart's response was that there will be added capacity in that there is currently no HOV lane in the northbound direction. There is only at present, a southbound direction. So there would be the capacity of a carpool lane, plus a HOV/HOT lane combination; which will add capacity.

Dr. Huang asked if the \$5M was gross revenue. Ms. Hart response was yes, this would be the estimated gross revenue. In addition, Dr. Huang asked about the annual operation and maintenance cost of the project. Ms. Hart indicated that it will be about \$1.1 to \$2.1 million per year; leaving the gross revenue to be about \$3.8 to \$4 million for either transit or for a HOV facility.

Mr. Hanna has about the congestion level in the HOV lane at present and how would that increase with the addition of solo drivers; which will augment what is already happening. Ms. Hart stated that currently it is not a high use carpool lane, that there are about 600 vehicles per hour in the lane, which is 600-700, which is not a high use. The way the formula is being developed to determine the cost of the trip, is to base it on about 1,300 so that what you are selling really is that capacity. Going from 600 to 1,300, if there are more carpoolers, then there will be more vehicles in the lane, less capacity that would be available the higher the price.

Mr. Brazil asked about the estimated air quality benefits at this time. Ms. Hart stated that an air quality analysis has not been conducted.

Mr. Dawid asked about the estimated revenue of about \$1.1 to \$2 million dollars that is anticipated to maintain the facility; of this amount how much of this will be used to maintain the added expense of having an HOT lane? Ms. Hart responded that it will include operating the facility, which will be the back office, contracting to use their account management. Other fees will be to pay for enforcement of the facility by the California Highway Patrol, and the utilities associated with the system. It includes some of the toll data centers. Ms. Hart stated that they are anticipating 1-2 staff members who will serve as customer service representatives, who will deal with just HOT lane issues only. The actual account service providers will be done by data.

Ms. Drennen had a question about the northbound construction and wanted to know if you have an estimate of \$3.9 million per year and you are looking at northbound construction costs would it be roughly similar to the southbound construction costs or slightly higher? Ms. Hart responded to Ms. Drennen and explained that for the HOV lanes it is much higher, and that it would be paid for over a long period of time. State legislation that is pending signature of the Governor is to allow for indeterminate length of time you can operate as a HOT lane. Currently, there is a four year demo period that was approved; this would take off the sunset. If that was done, there would be an allowance for bonding to be able to move on the northbound facility to bond for the improvements and then use the revenues to pay for that, along with transit service.

Ms. Drennen asked if the express buses were the most useful use of the transit money if there is significant transit demand for that service itself, or could it go to augment enhance current transit service and asked who are the individuals dealing with the transit side of it. Ms. Hart stated that is one of the issues that will be tackled when the Joint Powers Authority does their first expenditure plan, which is estimated to be done by 2009, to determine where the revenues go and a part of that will be so what is the next call. Ms. Hart stated that it would probably be transit for some time and what does that look like? Will it be a combination of express and localized service, but feels that everyone would want enhanced service in the corridor, but at this point it is unknown.

Final question from Ms. Drennen regarding the air quality benefits and stated that she was surprised that the project has not gone through and wondered if it was in the EIR stage. Ms. Hart informed Ms. Drennen that there is environmental clearance, and there was an environmental document that done for the HOV lane and that just the add on for the HOT lane and that was done two years ago and was a Cat Ax, because it was considered to be categorical exclusion and exemption because it is primarily the ITS portion of managing it.

Chairperson Blonski again thanked the speaker and provided Ms. Hart with a token of the Committee's appreciation.

Dr. Holtzclaw asked one final question with regard to how much money would be generated that would be applied to transit service per year. Ms. Hart estimated that this is just a guess, as this is a policy decision by the Joint Powers Authority, that it would probably be at least 50% after the maintenance.

Dr. Holtzclaw also asked if there has been any consideration given to considering rather than constructing the HOT/HOV lanes Northbound; taking a lane and Ms. Hart responded that that has not been discussed at this time.

Ms. Elizabeth Bent, Senior Transportation Planner, San Francisco County Transportation Authority presented to the Committee the Mobility, Access and Pricing Study for downtown San Francisco; and the San Francisco Doyle Drive Value Pricing program.

Ms. Bent provided the Committee with an overview of the Transportation Authority, noting that it is a congestion management agency for San Francisco and in that role, monitors the congestion on the streets and roads, but also manage the half cents sales tax dedicated to transportation improvements in San Francisco; which is Prop. K.

Ms. Bent indicated that her discussions with the Committee would be spent on the mobility, access and pricing study, as well as the urban partnership program through the Department of Transportation, as well as the congestion problem. As some individuals are completely convinced that congestion is horrible in San Francisco and that some people think it is not as bad as New York and that we have a lot of time to address the issue.

Ms. Bent's presentation consisted of two maps showing congestion in San Francisco with transit routes operating below 8 mph and some operating at 3-4 mph. Auto routes operate below 10 mph, and freeway routes operate below 30 mph.

Travel in downtown San Francisco, there are about 1,000,000 daily trips and about 400,000 trips during the peak period in this same area. During the daily mode share, half of those trips are by car. Mode share during the peak period is better, but would like to figure out a way to make people's transit options a lot better, as well as improve the overall traffic flow on the streets.

When looking at the travel to downtown San Francisco, in particular the transit mode share, by region; what was found is that it is doing pretty well from the East Bay, but when looking at the South Bay and the Peninsula, we are only capturing about 23% of the transit trips. Ms. Bent stated that this is something that we are seeing not only because of the amount traffic congestion on the freeways and access into the city from the South, but it is also noticed that

the North Bay and the East Bay are already controlled by some sort of pricing system, because they are tolls on those bridges.

When looking at congestion in San Francisco, it is noted that half of an average regional trip is spent simply sitting traffic. This number could increase by 2030, which is considered the Horizon Year. Also, when looking at where the congestion delay is experienced the most, and where it is worst, it was noted that Downtown and SOMA experienced about ¼ of the regional delay.

Many wonder how does transit fair in terms of congestion and because so many of our streets are mixed use traffic, a lot of congested auto routes are also transit routes. It was noted that bus speeds are 9-35% slower than auto speeds and that transit reliability hovers around 70%, which many of those lines are operating below 8 mph. Ms. Bent stated that this is a decrease in funding for transit, and an increase in the standard for on time reliability.

Ms. Bent noted that when she spoke to folks at the Transit Effectiveness Project, that MTA is running, what was stated that their top concerns are better reliability, faster travel times and more peak service and feels that these are all things that a congestion pricing program could help to deliver.

Ms. Bent indicated that when looking at the environment, that individuals are already aware that congestion has an impact on air quality. Private autos produce about 47% of emissions in San Francisco alone in 1990. This number will increase in the next couple of years, as San Francisco currently has a very aggressive greenhouse gas emissions reduction target, and at present is coordinating with S.F. Environment and the Air District on the Climate Action Plan, and how we can use congestion pricing to implement some of the programs. Questions were raised in the past with regard to why is MUNI not more efficient. Ms. Bent indicated that only 1% of greenhouse gas emissions in San Francisco are produced by the transit fleet.

In looking at the economy, it was calculated that the cost of lost time, to out of pocket costs from excess fuel and also to goods movement. In the region, this number is about \$42B in 2005 and in San Francisco alone it is \$2.3B. This number is anticipated to increase by 2030 to about \$3.8B. The effort will be made on how to do better and to give people back that lost time and to helping people to not simply not through out costs in terms of fuel. As fuel prices rise, the numbers could also rise.

While looking at the quality of life in other cities it was noted that congestion pricing programs have been able to deliver significant changes to the quality of life. Road safety has increased, through a decrease in pedestrian injuries and also, there is an estimate of about 20% increase in bicycle trips in London for example. Ms. Bent noted that it is a part of their program, but like to see if this could be delivered in San Francisco.

Ms. Bent asked why should congestion pricing be considered for this particular tool in managing congestion. Ms. Bent stated that this is an economic tool that has been around for many years and has been used in many other industries as well. It is a way to manage and under price scarce resources, which is typically over used. The successful implementation in London as well as Stockholm and several other cities have shown that there is political acceptance of a program like this and public acceptance as well. Lastly, it shows that the

technology is there and had advanced to a place where it can actually support a system; rather than hinder a system like this.

Ms. Bent stated that congestion pricing is also contained in the countywide transportation plan, which is part of the Prop. K plan which is the expenditure plan for the countywide transportation plan, which was approved by the voters and also a part of the Climate Action Plan. When looking at the transportation action categories; discouraging driving is a category that congestion pricing falls within, but it is also a way to implement some of the other programs that are contained in that category, like increasing the use of public transit, increasing the availability of ridesharing and these are some of the things that we would like to look when we are speaking about reinvesting in the package of improvements for mobility.

Congestion pricing for San Francisco is a package, which involves a fee that is paid by the motorist on congested areas or on key congested routes, but the revenues are reinvested into improving the transportation options. When the program is being evaluated and the different alternatives that exist, they will be evaluated as a package. To try to understand not only the cost of administering the program, but the cost of delivering the other options that would help to support the choices that people will make. When talking about how those choices flesh out, we want to understand how many people might shift their travel to a different time of day, for example they might drive in at 7:00 a.m. instead of 8:30 a.m.

Lastly, public outreach and awareness are very key pieces of a program like this, to make sure that people understand both before their trip and during their trip, when they are entering a price area, and how they can make a better choice if they choose to do that. There are also multiple different ways of paying in Stockholm. For example, people can pay their fees at 7-Eleven and that is something that we want to understand that there are traditional ways of paying, but also can we reach out to the business community and other industries to understand how we can leverage their sectors as well.

Several case studies have been completed and are looking at different cities to understand what is the footprint for a program like this and how would it flesh out in San Francisco. In London, there is an all day flat fee charge that is levied between 7:00 a.m. – 6:00 p.m. and the charge does not vary. When looking at Stockholm, the charge does vary over the course of the day. It is highest in the peak of the peak and lowest at the end of the day, but then there is a much lower charge in mid day. What was found is that there are a range of benefits that reduce delays in traffic as you would expect increase speeds, but better transit reliability and higher transit ridership; decreasing greenhouse gas emissions and pedestrian injuries, as well as substantial net revenues that help to fund the program.

The most congested area in San Francisco will be geared towards zone based schemes, sort of figuring out if there is a program that can be designed that focuses on this area; but if there are other potential alternatives. Can the key routes be identified that might be charged or key gateways into the city that we may want to charge.

Some of the goals/benefits of congestion pricing include:

- Improving system performance and investment
- Improved travel times

- Reduced travel time variability
- Increased speeds
- Increased non-auto mode share

Enhancing environment and quality of life

- Improved air quality
- Improved road safety
- More leisure time, participation in civic life

Maintaining economic vitality

- Efficient goods movement (reliable deliveries)
- Improved trips to trade, retail, employment centers
- Decreased travel costs for individuals and businesses

Supporting growth

- Consistent with Transit First Policy
- Better land use decisions

A defined package will be presented to public at workshops throughout the study and also using the feedback to incorporate and refine those alternatives and also again, determine the cost and revenues of potential packages not of just one piece of the system. Many areas will be reviewed, as there are about seven different tasks in this study that is being focused on including public participation, the technology, as well as the financial and economic impacts and benefits.

Ms. Bent noted that at present, the agency is in the process of expanding the travel demand model, to understand how people within the region would react to a program as such. There is a San Francisco based model that is very robust, but because it would be a regional impact the agency would like to understand how folks in the nine county regions would react. Alternatives are also being designed that would be analyzed throughout the program and discussions with transit operators both locally and regionally have been held to understand what is the horizon of improvements that have within the timeframe that a system might be implemented over the horizon year 2030. How can we either speed up the improvements, devise more and what they look like and what are their particular constraints for delivering new transit services.

Recommendations on a potential program should be completed by Summer 2008.

The United States Department of Transportation (USDOT) announced that they would make about \$1B available to up to five cities to invest in congestion management programs. However, the package includes the 4T's of congestion management which include:

- Tolling (congestion pricing);
- Transit and ferry investments;
- Technology; and
- Telecommuting

San Francisco was successful in competing for this program, one of only five cities in the nation. There is a possibility that San Francisco could receive up to \$159M in grant funds to improve congestion in the bay area.

The key piece of this program is the value pricing program on Doyle Drive, which means tolling Doyle Drive. This has been contemplated for many years, to fill the funding gap for the replacement project on Doyle Drive.

Several agencies are collaborating on this project, as many different agencies contributed to the bay area's urban partnership proposal, which includes MTC, MTA, the Golden Gate Bridge District and Caltrans. Legislative authority is needed to access the grant funds.

The Doyle Drive replacement project will include a parkway design that would allow people to reconnect with the environment, Crissy Field, the Marina and the Presidio on both sides of Doyle. Also, it would be a much safer facility, with slightly wider lanes.

This is the highest priority safety project in the state and it the worst rated bridge in the state for seismic safety and it also have a sufficiency rating with the federal government of 2 out of 100; which is pretty bad.

This is an \$810M project, \$605M committed in state and local funds. The existing facility tolled to fill fund gap with an estimate of \$165M.

Elements of the program are:

- Doyle Drive Value Pricing Program (1);
- Arterial management (2, 3);
- Smart Parking (4);
- Integrated mobility account; and
- Expansion of city telecommuting program

The travel patterns within Doyle Drive include:

Most trips destined for downtown

- 120,000 daily
- 58,000 inbound
- 16,500 inbound during AM peak

Most trips from North Bay

- 85% during AM peak hours
- 70% during off-peak hours

Tolling Design:

- Preliminary toll studies: \$1-\$2/day could shift 10%-12% of traffic to off-peak or transit;
- Updated toll study to be conducted pending CHAMP 4.0 model completion

The Mobility, Access and Pricing Study (MAPS) are a feasibility study. This is a chance to understand how pricing for mobility can be used in San Francisco on a broader scale and try to identify the particular areas that we might focus on and whether or not it is feasible. The Urban Partnership Program is a demonstration project, and the idea is to lead back to this idea of skepticism, whether or not government can deliver and to demonstrate the value of a program like this.

In addition, UPA demonstrating value it will:

- Close Doyle funding gap with self-help;
- Manage peak period demand;
- Showcase technology;
- Concept of re-investing revenue in the Doyle 101 corridor; and
- Build public trust in government to deliver
 - Transparent public process
 - Public participation

The monitoring and evaluation of Doyle program will help inform decision-making for potential area-pricing in San Francisco.

Ms. Bent concluded her presentation.

Mr. Dawid noted that the presentation was excellent. Mr. Dawid asked about the downtown mobility project, and mentioned cordoned pricing which is what New York City is doing, stating that anybody below 85th Street will get charged and even if you live within the zone you are charged half. There are several ways to design a zone based system, as you can charge people that are coming in and out or you can charge in/out and within. The question that everyone is trying to understand is how do folks traveling within travel today? Are most of these people already on transit and is there any benefit to charging them for driving? Also, in other cities they have been able use residence discounts so that is another thing that will be considered.

Ms. Bent also indicated that New York's program charges up to \$8 a day and a flat fee. At present, the agency is looking at different ways that they can vary the fee to understand how people are traveling in the middle of the day, in particularly because they want to make sure that the downtown businesses are still active and that people are still coming downtown to shop.

Mr. Dawid also noted that he looked at MTC's website and encouraged the Committee to also view the site and see the San Francisco Bay Area Accelerate Projects funded by USDOT. Mr. Dawid stated that the biggest chunk of money out of that \$159M is \$58M that is going to the SF Go Arterial Traffic management. Mr. Dawid asked how much of that, since that is the biggest chunk and the Doyle Drive tolling is only getting \$12M and \$35M going toward the rebuilding. Out of the \$58M how much in general is VRT as there are several VRT corridors within the city; how much of the \$58M will benefit VRT generically within San Francisco?

Ms. Bent indicated that it is a pretty sizable amount, since some of the corridors that are destined to have these SF Go improvements are Geary and VanNess and because the 38 Line runs on Geary and runs into the downtown area. It will benefit, as the idea was to leverage the existing transit system in the transit corridors and because they are street based improvements, Golden Gate Transit Buses that are traveling on those corridors will also benefit.

Mr. Brazil asked about the definition of traffic. Ms. Bent responded it is calculated between the difference between the time your trip actually takes and the free flow travel time.

Dr. Huang had a broader question in general, asking Ms. Bent her thoughts or anticipation would be the obstacles that will either slow the project down or abort it; and what strategies have been considered. Ms. Bent indicated that the agency is conducting a significant amount of public outreach, as this is something that is not yet experienced in the bay area. Particularly when it comes to the concept of peak period pricing, when going to New York for example, you have peak period pricing on the trains as well as on the roads, when you look at the tolls and things like that. So that is something that people will need to understand what that means and educate people on how that works, and also collecting that feedback in trying to understand what the improvements need to be.

Ms. Bent noted that what was found in the feasibility study is that people are really wondering about the affordability and the business impacts and this has been seen in other cities, which was broadly neutral or an improvement. Many folks that are lower income do support programs like this. The business impacts vary on how the program is designed. For example in London, there was a broadly neutral impact on downtown businesses; but in Stockholm there was actually a 5% increase in retail revenues.

Also, Ms. Bent indicated that the technology is not an obstacle, because the technology is there, it is just a question of how it is designed.

Dr. Huang indicated that his understanding is that both London and Singapore were able to get the program through because of the very strong government pressure and wanted to know how much support do they have at this time? Ms. Bent indicated that their Board suggested that they apply for the feasibility study funding for that grant and the Board was very interested to see whether or not this is something that could work here, because it has worked so successfully in London and Stockholm and several other cities.

Dr. Holtzclaw thanked Ms. Bent and asked about the North Bay at 42% by transit and 23% from the South Bay and Peninsula. That we should be thinking very strongly about the South Bay and Peninsula and wanted to know their plans with using the revenues and tolling coming up from the South; recognizing that state and federal freeways are hard to put into a tolling system. Ms. Bent informed that Committee that they are not considering tolling the freeways themselves, as they do not have the authority to do so, as this program is designed to focus on the design of the city streets. This makes it more difficult, because the boarder to the south corridor is most poor and there are many other access points.

Chairperson Blonski thanked Ms. Bent and commented that the presentation was excellent and also presented her with a gift on behalf of the Air District.

Speakers: The following individuals spoke on this agenda item:

Gerald Cauther
900 Paramount Road
Oakland, CA 94610

Normal Rolfe
S.F. Tomorrow
2233 Larkin St., #4
San Francisco, CA 94109

Ms. Drennen noted that in response to the speakers that she has drafted a resolution and perhaps passing the resolution today about these issues and wanted to check with Chairperson Blonski and the Committee as a whole.

Chairperson Blonski asked for any opinions by the Committee and some members suggested that they not make any decision at this time, but would like to hear the resolution.

Action: To calendar a discussion of a resolution in reference to agenda item 4.

Mr. Dawid noted that Ms. Drennen is right on target and that the Committee has seen three excellent presentations today and would like the idea of getting the resolution in the minutes. Chairperson Blonski suggested that Ms. Drennen read the resolution. Ms. Drennen began reading the following:

WHEREAS, high-occupancy toll lanes (HOT lanes) offer carpool priority to solo drivers willing and able to pay a toll; and

WHEREAS, HOT lanes are a new and unproven transportation mechanism that could impact air quality through induced traffic demand and increased emissions from increased travel speed, and

WHEREAS, HOT lane projects have the potential to greatly influence several social equity issues such as: an income-segregated resource, reduce travel times for current users of HOV lanes; and

WHEREAS, HOT lanes are often touted for their potential to fund new transit service, but there are currently no agreed-upon targets for funding transit operations.

THEREFORE BE IT RESOLVED that the BAAQMD Advisory Council urges the Air District to develop policy guidelines for HOT lane projects including: air quality impacts; social equity concerns; and setting a minimum percentage of revenue to be dedicated to transit from HOT lanes.

Chairperson Blonski asked if there was any discussion and Mr. Hanna commented that this was just a proposition for something that the Committee may want to consider next time.

Chairperson Blonski requested that this resolution be part of the discussion on, the agenda for the upcoming meeting; which the Committee agreed. Dr. Holtzclaw suggested that he would like to see as a part of this, the potential of any capacity expansions to increase traffic and impact air quality.

- 5. Committee Member Comments/Other Business.** Chairperson Blonski thanked Mr. Dawid for putting this meeting together and contacting the speakers and felt he did an excellent job. Mr. Dawid thanked Mr. Burch.

Chairperson Blonski's final comment was that he was pleased with the meeting.

- 6. Time and Place of Next Meeting.** 9:30 a.m., Wednesday, December 10, 2007 – 939 Ellis Street, San Francisco, CA 94109.
- 7. Adjournment.** 11:57 a.m.

Vanessa Johnson
Executive Secretary

Bay Area Air Quality Management District
939 Ellis Street
San Francisco, CA 94109

DRAFT MINUTES

Advisory Council Public Health Committee
1:30 p.m., Wednesday, October 10, 2007

1. **Call to Order – Roll Call.** Chairperson Bramlett called the meeting to order at 1:38 p.m. **Present:** Chairperson Jeffery Bramlett, Janice Kim, Ph.D., Steven Kmucha, MD., Ms. Linda Weiner, Mr. Brian Zamora, and Ms. Licavoli-Farnkkoph, MPH. **Absent:** Ms. Cassandra Adams.
2. **Public Comment Period:** There was none.
3. **Approval of Minutes of June 13, 2007:** The minute was approved and carried unanimously.
4. **Continued Discussion on Indoor Air Quality (IAQ) and Asthma:** Chairperson Bramlett initiated the discussion on Indoor Air Quality and Asthma stating that this is a first draft and an opportunity to make changes. Mr. Bramlett reminded those present that the recommendation that he read out at the full Advisory Council meeting are shown in the draft. Mr. Bramlett explicitly stated that there might be a final draft by December, however it would rather be worthwhile to take time to do the complete product of the recommendation that the committee is happy with than a document pushed through to meet the December deadline.

Mr. Zamora suggested that Members send their text changes of the recommendation electronically to Mr. Bramlett, but Mr. Bramlett reiterated that those changes can be discussed if Mr. Zamora has them handy in order to maintain good information communication at a better pace.

Ms. Weiner stated that there is more current information from the American Lung Association on levels of criteria air pollutants than 1997 and will send those to Mr. Bramlett.

Mr. Bramlett clarified to the Committee that the purpose of the draft document is to precipitate clarity where need be. Mr. Bramlett reiterated that his understanding from the ongoing discussion is that the subject be changed to 'Strategy for Asthma as it Relates to Indoor Air Quality,' Mr. Zamora added that for the implication, the Committee will extract the relationship between outdoor and indoor air quality and the resulting concerns. The Committee unanimously agreed on the revision of the subject matter.

Dr. Kim inquired if the Committee will present the draft to the full Council. Mr. Bramlett responded that he had already reported to the full Council on the scope of the recommendations so the Council is informed and if there are any new recommendations, he will include it in his chairperson's report during the meeting.

Dr. Kim inquired of previous presenters like Peggy Jenkins and their presentations. Mr. Bramlett responded that Peggy Jenkins had presented to the Committee, minutes of those meeting and three presentations in particular will be sought and at Mr. Bramlett's request; be forwarded with attachment to the Committee members. It was agreed that staff will see the draft recommendation sometime in late January 2008.

Ms. Weiner will search for a list of Asthma Coalition within the Air District's jurisdiction to be added to the draft as well. Mr. Zamora will also identify with the County Public Health Organization best contacts to be available as the resource draft are compiled.

Mr. Bramlett notified the Committee that Dr. Tony Iton was scheduled to speak at the meeting today but was canceled. Mr. Bramlett also notified the Committee that Dr. Moro from San Mateo County advised that Asthma Coalition will be the best to contact with the County Health Officers. Mr. Bramlett informed the Committee that there was a request to facilitate communication between the Air District and the County Health Officers and by tangent, Mr. Jack Broadbent, Air Pollution Control Officer (APCO) spoke at the County Health Officers' annual retreat of Friday, October 5, 2007. Mr. Bramlett also threw the question open on how to contact the Asthma Coalition concerning the information the Committee needs or whether the direction so far is satisfactory.

Ms Weiner suggested that it will be worthwhile to list the information on the website and Mr. Bramlett agreed that it will be left for staff to list the information on the website. Mr. Bramlett reiterated that input from members will get to him by October 24, 2007 and he will put them together and subsequently send back to members.

5. Presentation on Health Effects of Traffic Exposure: Dr. Janice Kim of Office of Environmental Health Hazard Assessment (OEHHA) presented on various health studies that are emerging because of living near busy roads. Dr. Kim stated that there have not been adequate regulations in place to address the protection of the public against air pollutants especially those living near sources. Dr Kim gave an overview of the presentation as:

- Traffic related pollution and some of the mechanisms to toxicity.
- East Bay Children's Respiratory Health Study – an example
- Other Studies on Health Effects of Living Near Busy Roads
- On-road exposures
- Information for policy makers

For background information, Dr. Kim stated that there are health impact related to the respiratory system, cardiovascular, cancer, birth outcomes; however most of these studies are based on large populations where their exposures are estimated by regional air monitors. Traffic-related emissions are major sources of urban air pollution, which contains many air pollutants. These pollutants are respiratory irritants, carcinogens and can enhance our immune response. Dr. Kim explained that the pollutants are extremely small, about 0.01micrometer compared to cells. There are a lot of studies that show that these pollutants can enhance allergic response, which can have multiple effects especially on the cilia and respiratory epithelia. There has been increased probability of epithelia lining and a cascade of a process where one gets enhancement of immune response through multiple mechanisms; this is summarized by the article Brook et al., *Circulation*. 2004; 109(21):265571. Also NO₂, ozone, diesel exhaust particulate (DEP) have been shown to enhance immune response on sensitize individuals; DEP can also induce an IgE response to new antigen.

Dr. Kim also stated that ultrafine particles are very small and impact the lower respiratory tract and cause local pulmonary inflammation due to inflammatory products that are released locally, it gets into the blood circulation and can lead to stress responses in the nervous system causing increase in heart rate, blood pressure thereby affecting the cardiovascular system.

Dr. Kim also noted that traffic related pollution contains so many pollutants and have higher concentrations near downwind of busy roads as illustrated by Zhu et al. *JAWMA*, 2002. These pollutants include particles, carbon monoxide, black carbon, NO₂; these pollutants are usually rapid drop of 100m to 300m downwind. It is noteworthy that most of our regional monitors are not situated near major sources thus not capturing hot spots.

Dr. Kim also highlighted the recent work that OEHHA is doing and other epidemiological studies stating that they are looking at home exposures by using Geographic Information System (GIS) techniques to estimate the proximity of residential areas to traffic exposures as it relates to risks of asthma symptoms.

Dr. Kim summarized that after taking into account all the variables, there are increased risk of about 20% of the population exposed to traffic that have higher risk of asthma symptoms of one to five times.

Mr. Zamora inquired if the make-up of the community was taken into account. Dr. Kim responded that demographics of race/ethnicity, as well as socio-economic status were taken into consideration but they did not really make a difference.

Dr. Kim also spoke on On-road exposure to traffic pollution citing Dr. Scott Fruin of UCLA's presentation. Dr. Fruin reviewed some of the existing studies that documented high exposures to vehicle exhaust on busy roads showing that particulate matter effect are about 5 to 15 times higher. Dr. Kim stated that an average

Californian spend 90 minutes per day in a vehicle and Air Resource Board estimated that 6% of daily driving can give up to half of our exposures.

Dr. Kim also cited Peters et al. study in Germany of about 700 subjects that had their first acute Myocardial Infarction (MI); the study stated that exposure to traffic within 1 to 2 hours prior to symptoms more than doubled the risk of MI. The study also considered whether taking public transportation and being in traffic lowers stress level.

Also, Dr. Kim commented on the study of exposure to ultrafine particles and DNA damage in Copenhagen; she stated that 15 healthy individuals were monitored for six days cycling in traffic and one 90 minutes indoor cycling. In the process, blood samples were taken to monitor ultrafine particle exposures, the result showed lower ultrafine particles on day of indoor cycling and higher ultrafine exposures correlated with higher evidence oxidative DNA base damage in blood cells.

Dr. Kim stated that in general, children of low income and of color are much more likely to live in high traffic density areas. Studying California schools and how close they are to busy roads, the result showed that schools located near busy roads have disproportionate number of children economically disadvantaged and nonwhite, thus it is a clearly environmental justice issue. Dr. Kim also stated that there has been legislation passed to limit school locating near busy roads; she also cited Los Angeles school district as struggle with finding school sites. ARB noted that citing of schools is based on local land use decisions and put together a guidance that recommends sensitive populations like nursing homes, schools, residential areas to be cited nothing less than 150m away from busy roads.

Dr. Kim noted that there are still some unresolved issues that this body of literature is proving and the first being that we are still grappling with issues that living near busy roads and higher exposure put one at a very high risk yet; it is still very difficult to quantify. It is not certain what constitutes busy roads but some ulterior roads can have up to 30,000 vehicles a day and have lots of pollutant from stop and go traffic. The second issue is what the important set of pollutants is in terms of source control and are there some other effective strategies to reduce exposures? Finally, do urban re-development, Smart Growth projects consider health impacts of building near busy roads?

Ms. Weiner asked what the Air District is doing in terms of land use policies and hot spots. Mr. Henry Hilken, Director of the Planning Division of the Air District responded that the Air District has been promoting smart growth for many years to reduce reliance on automobile and sometimes the policies would resolve in residential areas being near sources of high levels of air contaminants. Mr. Hilken noted that the Air District is concerned with questions of how much traffic is high traffic, which air pollutants should cause worries, how much of a buffer zone should be considered and are there other mitigation strategies beyond a buffer zone that might be helpful. Mr. Hilken also confirmed that these issues are being addressed by CARE program which will eventually provide needed data to cities and counties. He also stated that

monitors are located not to reflect hot spots noted that there is grant underway from EPA that will supplement Air District resources to do some intensive monitoring starting in West Oakland.

- 6. Committee Member Comments/Other Business:** Chairperson Bramlett announced that Regulation Rule 6, wood burning devices workshop is coming up; from November 7 and 26 2007, interested members should meet with him for the notice.
- 7. Time and place of next meeting:** 1:30 p.m., Wednesday, December 12, 2007, 939 Ellis Street, San Francisco, CA 94109.
- 8. Adjournment:** The meeting adjourned at 2:50 p.m.

Chioma Dimude
Acting Executive Secretary

BAY AREA AIR QUALITY MANGEMENT DISTRICT

Memorandum

To: Chairperson Mark Ross and Members
of the Executive Committee

From: Jack P. Broadbent
Executive Officer/APCO

Date: October 30, 2007

Re: Size of Governing Board

RECOMMENDED ACTION:

Decide if current statutory language concerning the Board of Directors is satisfactory, or if changes are needed.

BACKGROUND

Per the direction of the officers of the Board of Directors, staff have agendized a discussion of the future size of the Board. Also per direction, staff have developed for the Executive Committee's consideration a number of potential changes to the Board's composition.

From 1955, when the District was initially formed, through the early 1970's, when the District grew to include the counties in whole or part of Napa, Solano, and Sonoma, the Board of Directors consisted of 12 local elected officials. Each county had two representatives on the Board, with one representative from the Board of Supervisors and one from local cities. The Board increased to 18 members when the number of counties changed from six to nine.

In 1976, the Board sponsored legislation that changed its composition. Under this new law, the population of a county determined how many seats it had on the Board. This 1976 law is still what governs the Board's composition today. Counties with a population up to 300,000 have one seat, while counties with population up to 750,000 get a second seat. A population up to one million yields three seats, while a population over a million yields four seats.

This 1976 law decreased the size of the Board from 18 to 15. From 15 in 1977, the Board has grown to 22 today. Within a year, this number will grow to 23, and to 24 shortly thereafter. The Board will continue to increase in size as the region's population grows to a theoretical maximum of 36 members.

At its current membership of 22, this Board has by far more Directors than any other air district in the State. Other Board sizes range from 5 members (for single-county Boards) to a high of 15 members in the San Joaquin Valley. (Their Board currently has 11 members, but will increase to 15 as a result of legislation pushed by environmental organizations this year.) The Bay Area Board is also unique in that it is the only air district to have a Board with a size that increases with population. All other districts have Boards of a fixed, and significantly smaller, size.

DISCUSSION

Per the direction of the Board officers, staff are bringing the issue of the Board's size to the Committee for your discussion. Also per direction, we have laid out some hypothetical scenarios to inform your discussion. These are summarized in the table below. In discussing these options, the Board may wish to consider what effect if any increasing its size may have on its effectiveness and ability to achieve its vision. The conventional wisdom on the size of governing boards is that too small a board results in too few ideas and too insular a vision. Small boards may lack diverse opinions and perspectives. The conventional wisdom also has it that too large a board size can also be limiting. Too large a board can in theory reduce the effectiveness of the different voices on the board, be procedurally and administratively cumbersome, and have multiple or competing priorities. Staff believe that finding the right balance between too big and too small can best and should only be decided by the Board itself.

	Maintain Status Quo, Plan A	Cap at 22, Plan B	Not More than 3 per County, Plan C	Not More than 3 per County, Plan D	Not More than 2 per County, Plan E	Not More than 2 per County, Plan F	One per County, Plan G
Total Board Size:	22	22	16	16	13	12	9
Estimate of Board Size 10 Years from Now:	Greater than 24; perhaps 26	22	Likely still 16	17 or 18	Likely 14	12 or 13	9
Alameda County 1/07 pop: 1.53M	4 members	4	3	3	2	2	1
Contra Costa County 1/07 pop: 1.04M	4 members	4	2	2	2	2	1
Marin County 1/07 pop: 256K	1 member	1	1	1	1	1	1
Napa County 1/07 pop: 136K	1 member	1	1	1	1	1	1
San Francisco 1/07 pop: 808K	3 members	3	2	2	2	1	1
San Mateo County 1/07 pop: 733K	2 members	2	2	2	1	1	1
Santa Clara County 1/07 pop: 1.81M	4 members	4	3	3	2	2	1
Solano County 1/07 pop: 292K	1 member	1	1	1	1	1	1
Sonoma County 1/07 pop: 425K	2 members	2	1	1	1	1	1

The easiest option is to make no changes to the Board's structure, but to continue with the status quo. As stated above, under this scenario the Board will quickly increase to 24 members, and will continue to grow into the future. One minor consequence of this growth is that the dais in the Board room is currently at capacity with 22 members. Growth beyond 22 will require an alternative arrangement for Board meetings, such as potentially renting a larger venue not at 939 Ellis Street to accommodate the larger Board, or a major physical change to the current Board room.

A second option, Plan B in the above table, would be to cap the Board's size at its current 22, and retain the current county membership distribution.

The next options would all reduce the size of the Board, but retain a population-weighted representation. Two options would reduce the maximum representation from a county from four members to three, and another two options would reduce this number to two. Under all of these scenarios, there is a common question of how the Board would transition from its current size to a smaller size. Staff would suggest that one way to address the transition would be for each current Board member to complete their term of service on the Board. This would have the effect that the smaller size of the Board would be reached over a period of up to four years.

Plan C would say that a county population less than 500,000 would generate one representative on the Board. A population between 500,000 and 1,500,000 would generate two representatives, and more than 1,500,000 would generate three representatives. This would produce a Board with 16 members, and that size should be fairly stable for many years.

Plan D would also have a maximum county representation of three, but with different cutpoints. Counties with a population of less than 700,000 would have one representative, with a second representative added for those counties up to 1,400,000. If the county's population is more than 1,400,000, there would be three Board members. This also yields a Board with 16 members, although this would increase to 17 quickly, and possibly to 18 within a decade.

Plans E and F would have either one or two representatives from a given county, depending on population. Plan E would use 750,000 as the cutpoint, and Plan F would use 1,000,000 as the cutpoint. These cutpoints would give total initial Board sizes of 13 and 12, respectively. Plan E would grow to 14 relatively quickly, and Plan F would be more stable.

The last option (Plan G) for consideration would be for each county to have one representative. Another non-population-weighted alternative would be a return to the pre-1976 Board, where each county had two members. Both options raise the issue for the Board to consider of whether a population-based plan is helpful to the Board in working towards its goals for the region.

If the Committee and ultimately the Board choose to pursue a statutory change to your composition, staff will work to accomplish the Board's directive. Staff believe that if there is consensus among current Board members on a change to your composition, that it would be possible to pass legislation to accomplish that change.

BUDGET CONSIDERATION/FINANCIAL IMPACT

Generally, a smaller Board would have a modest benefit to the District's budget. But staff note that

even at 22 members, total costs associated with the Board are roughly \$317,000. This is a relatively small percentage of the District's total budget.

Respectfully submitted,

Jack P. Broadbent
Executive Officer/APCO

Prepared by: Tom Addison

BAY AREA AIR QUALITY MANGEMENT DISTRICT

Memorandum

To: Chairperson Mark Ross and Members
of the Executive Committee

From: Jack P. Broadbent
Executive Officer/APCO

Date: November 5, 2007

Re: Regional Gas Fee

RECOMMENDED ACTION:

Consider possible joint legislative action with the Metropolitan Transportation Commission.

BACKGROUND

On November 9th, the Legislative Committee of the Commission will consider the idea of a regional fee on gasoline as part of their 2009 legislative program. Commission staff are suggesting that the proceeds from such a fee could be used to reduce the region's contribution to climate change, and maintain local streets and roads. District staff have had discussions with Commission staff about this idea, and are bringing this item to the Executive Committee for your guidance and direction.

DISCUSSION

The Commission has had statutory authority since 1997 to seek voter approval of a regional gas tax of up to 10 cents per gallon. Recent Bay Area polling indicates majority support for a regional fee on gasoline of ten cents per gallon (and even higher) if the funds were used to address climate change. While taxes require a two-thirds supermajority vote of the public, fees require a simple majority. While much has been written about the differences between a fee and a tax under the California Constitution, in essence fees must have a clear nexus between the payer's activities and the alleged adverse effects addressed by the fee. The fee cannot be levied for unrelated purposes, and the fee amount must bear a reasonable relationship to the burden created by the actions of the fee-payers. The Commission will discuss whether to pursue legislation allowing a vote of the people on a regional fee on gasoline in the Bay Area.

The polling results will be available prior the November 19th meeting of the Executive Committee, and staff will have these results for your consideration, as well as any action by the Commission.

The Board has consistently expressed leadership in working to address climate change. The consumption of gasoline in motor vehicles in the Bay Area is the largest source of greenhouse gases. There are multiple programs that could cost-effectively cut climate-changing emissions from vehicles if funds were available. Staff are seeking direction from the Committee on

whether to partner with the Commission in working on legislation to cut greenhouse gases through a fee on gasoline.

BUDGET CONSIDERATION/FINANCIAL IMPACT

Respectfully submitted,

Jack P. Broadbent
Executive Officer/APCO

Prepared by: Tom Addison

BAY AREA AIR QUALITY MANAGEMENT DISTRICT
Memorandum

To: Chairperson Ross and Members
of the Executive Committee

From: Jack P. Broadbent
Executive Officer/APCO

Date: November 13, 2007

Re: Financial Assistance Programs for Small Businesses

RECOMMENDED ACTION:

Receive and file.

BACKGROUND

During discussions of proposed Regulation 6, Rule 2: Commercial Cooking Operations, several Board members have asked about economic impacts of District rules on small businesses.

DISCUSSION

Staff will brief the Committee on impacts of District rulemaking activity on small businesses, including:

- Examples of District rules affecting small businesses and the associated costs;
- District economic analysis during rule development;
- Financial assistance programs for small businesses.

BUDGET CONSIDERATIONS/FINANCIAL IMPACT

None.

Respectfully submitted,

Jack P. Broadbent
Executive Officer/APCO

Prepared by: Dan Belik
Reviewed by: Henry Hilken

BAY AREA AIR QUALITY MANGEMENT DISTRICT

Memorandum

To: Chairperson Ross and Members
of the Executive Committee

From: Jack P. Broadbent
Executive Officer/APCO

Date: November 15, 2007

Re: Status of Carl Moyer Program Audits

RECOMMENDED ACTION:

None.

BACKGROUND

Staff has executed a series of actions to improve the District implementation of the Carl Moyer Program. These actions followed a state-wide audit of the program. Accomplishments include remediation of past project files, implementation of new controls, reallocation of matching funds, acceleration of Moyer processes, and review of outreach.

The audit was initiated in March of 2006 when Senator Dean Florez requested that the Bureau of State Audits (BSA) conduct a performance audit on management of programs that administer State Carl Moyer Program funding. The request was directed towards programs implemented by the Air Resources Board (ARB) and four Air Districts: the South Coast Air Quality Management District, the San Joaquin Air Pollution Control District, the Sacramento Metropolitan Air Quality Management District and the Bay Area Air Quality Management District. The request indicated three areas of focus: the efficiency and equity of the application process, the effectiveness of project selection and funding distribution in emission reduction and public health protection, and the availability and quality of public information and public outreach to ensure participation.

Following the request from Senator Florez, the ARB announced that it would also perform project audits of the Carl Moyer Program at the four Air Districts (the first audit in the nine year history of the program). The ARB also requested that the Department of Finance (DOF) conduct the financial portion of the ARB audit. The BSA and ARB audits occurred simultaneously.

DISCUSSION

Staff will present the actions taken in response to the audits. Staff will also present the resulting response of the auditing agencies to those actions.

BUDGET CONSIDERATION/FINANCIAL IMPACT:

This update is provided for information only and has no budget impact.

Respectfully submitted,

Jack P. Broadbent
Executive Officer/APCO

Prepared by: Jeff McKay

BAY AREA AIR QUALITY MANAGEMENT DISTRICT
Memorandum

To: Chairperson Mark Ross and Members
of the Executive Committee

From: Jack P. Broadbent
Executive Officer/APCO

Date: November 13, 2007

Re: Joint Policy Committee Update

RECOMMENDED ACTION:

Receive and file.

DISCUSSION

At the November 19, 2007, meeting of the Executive Committee, Ted Droettboom will provide an update on the activities of the Joint Policy Committee.

BUDGET CONSIDERATION/FINANCIAL IMPACT

None.

Respectfully submitted,

Jack P. Broadbent
Executive Officer/APCO

BAY AREA AIR QUALITY MANAGEMENT DISTRICT
Memorandum

To: Chair Mark Ross and Members
of the Board of Directors

From: Jack P. Broadbent
Executive Officer/APCO

Date: November 27, 2007

Re: Report of the Legislative Committee Meeting of November 26, 2007

RECOMMENDED ACTIONS

None. For information only.

DISCUSSION

The Legislative Committee met on Monday, November 26, 2007 and staff presented a summary of the recently-concluded year in Sacramento and highlighted the outcome of measures on which the Air District adopted positions. One significant bill signed into law was AB 118 (Nunez). The bill will generate over \$210 million annually through 2016. The funds will come from an increase in vehicle fees and will fund three air quality programs: 1) an enhanced state vehicle scrappage program, 2) the Alternative and Renewable Fuel and Vehicle Program, and 3) the Air Quality Improvement Program.

The Committee discussed potential legislative proposals for the Air District's legislative agenda for 2008, including possible joint legislative action with the Metropolitan Transportation Commission regarding a regional gasoline fee and the feasibility of a state-wide woodburning regulation.

Committee Chair Brad Wagenknecht will give an oral report of the meeting.

BUDGET CONSIDERATION/FINANCIAL IMPACTS

None.

Respectfully submitted,

Jack P. Broadbent
Executive Officer/APCO

Prepared by: Mary Romaidis
Approved by: Mary Ann Goodley

BAY AREA AIR QUALITY MANAGEMENT DISTRICT
 Memorandum

To: Chairperson Wagenknecht and
 Members of the Legislative Committee

From: Jack P. Broadbent
 Executive Officer/APCO

Date: November 13, 2007

Re: Summary of 2007 Legislative Year

RECOMMENDED ACTION: None (informational item)

BACKGROUND

The 2007 legislative year has ended, although the two-year session continues in 2008. Of the thousands of bills introduced this year, 964 were passed by the Legislature. Of these, the Governor signed 750, and vetoed 214. This report touches on both the air quality measures that became law as well as those that did not.

DISCUSSION

From an air quality perspective, 2007 was substantially less notable than 2006. Nothing near the magnitude of last year's AB 32 (on climate change) became law this year. The most significant air bill that was signed into law was AB 118, authored by Assembly Speaker Nunez. This bill was essentially crafted in the last week of the legislative session, and thus received little public and legislative review. Through a variety of increased fees, it funds three air quality programs: an enhanced state vehicle scrappage program, the Alternative and Renewable Fuel and Vehicle Program, and the Air Quality Improvement Program. Cumulatively, this bill will generate over \$210 million annually through 2016. The funds come from an increase in vehicle fees, such as the annual registration fee, drivers' license fees, and the smog check exemption fee that new vehicles pay. While the bill is generous with fees and funds, it is much less generous with the specifics of how these programs will work. These details will be fleshed out in regulations still to be developed, primarily by the Air Resources Board and the Energy Commission.

The following table highlights the 14 bills that the District adopted positions on.

<i>Bill</i>	<i>Brief Description</i>	<i>BAAQMD Position</i>	<i>Outcome</i>
AB 218 Saldana	Eliminates current loophole allowing vehicle registration without smog certificate	Support	Failed to pass Legislature

AGENDA : 4

AB 463 Huffman	California Clean Ferry Act of 2007	Support	Dropped by author
AB 493 Ruskin	Establishes fees and rebates respectively at the time of sale of high and low-emitting new motor vehicles	Support	Failed to pass Legislature
AB 575 Arambula	Prioritizes Proposition 1B air quality bond funding to South Coast and San Joaquin	Oppose	Failed to pass Legislature
AB 616 Jones	Requires annual (instead of biennial) smog checks for cars at least 15 years old currently in the program	Support	Failed to pass Legislature
AB 619 Emmerson	Amnesty for vehicles that committed title fraud	Oppose	Failed to pass Legislature
AB 846 Blakeslee	Clean Marine Fuels Tax Incentive Act	Support	Failed to pass Legislature
AB 934 Duvall	Would prohibit air districts from adopting airborne toxic control measures for non-stationary sources	Oppose	Failed to pass Legislature
AB 1077 Lieber	California Plug-in Hybrid Electric Vehicle Leadership Act of 2007	Support	Failed to pass Legislature
AB 1209 Karnette	Establishes health-based criteria for distribution of Prop 1B air quality funds	Oppose	Failed to pass Legislature
AB 1470 Huffman	Solar Water Heating & Efficiency Act of 2007	Support	Chapters
SB 509 Simitian	Requires ARB to adopt regulations to limit formaldehyde emissions from composite wood to EU standards	Support	Failed to pass Legislature
SB 587 Runner	Establishes exemptions from air district permit requirements for certain printing, coating, adhesive application, and laminating operations, subject to specified criteria	Oppose	Failed to pass Legislature
SB 974 Lowenthal	Establishes a container fee of \$30 per twenty-foot equivalent unit at LA, Long Beach, and Oakland ports	Support	Failed to pass Legislature

On the positive side, none of the bills the District opposed passed the Legislature.

On the other hand, most measures that we supported that would have improved air quality were defeated. Some, such as SB 974, AB 616, AB 1077, and AB 218, made it virtually all of the way through the Legislature. These measures are still alive, and could still become law in 2008. In particular, the container fee bill, which would fund substantial emissions reductions at the ports, is the subject of ongoing negotiations between the Governor's office and Senator Lowenthal.

A list of all the bills of potential air quality significance that the District tracked, and their outcomes, is attached to this memorandum.

BUDGET CONSIDERATION/FINANCIAL IMPACT

None.

Respectfully submitted,

Jack P. Broadbent
Executive Officer/APCO

Prepared by: Thomas Addison

BAAQMD BILL DISCUSSION LIST

November 26, 2007

* Bill significantly amended since District adopted position

BILL NO.	AUTHOR	SUBJECT	BAAQMD, OTHER AGENCY POSITIONS	STATUS
AB 6	Houston	Would require (instead of allow) ARB to adopt market-based programs to implement AB 32		Failed passage
AB 94	Levine	Would increase current goals for renewable electricity production to 33% of total power by 2020		Failed passage
AB 99	Feuer	Expresses legislative intent that 50% of new cars sold in California by 2012 use clean alternative fuels		Failed passage
AB 109	Nunez	Requires ARB to annually report to the Legislature on the implementation of AB 32 of 2006		Failed passage
AB 114	Blakeslee	Requires CEC by 2010 to develop a program to encourage, for industrial sources, containment, scrubbing, and capture technologies for carbon dioxide		Failed passage
AB 118	Nunez	Funding for emission reductions and alternative fuels		Chaptered
AB 217	Beall	Would change current annual vehicle license fee to biennial, with total amounts paid not changing		Failed passage
AB 218	Saldana	Eliminates current loophole allowing vehicle registration without smog certificate without penalty	BAAQMD, MTC Support	Failed passage
AB 233	Jones	Increases penalties for idling diesels		Chaptered
AB 236	Lieu	Revises purchasing criteria for state fleet		Chaptered
AB 242	Blakeslee	States legislative intent that early reducers of carbon emissions be rewarded with credits, in effect promoting a market-based implementation of AB 32		Failed passage
AB 255	DeLeon	Establishes Clean Air and Energy Independence Fund, funded with a \$4 annual increase in fees paid by vehicles less than 7 years old currently exempted from smog check; administered by ARB		Failed passage

AB 294	Adams	Addresses manganese particulate matter in the air		Chaptered
AB 307	Hayashi	Exempts fuel cell transit buses bought by public agencies from sales tax		Failed passage
AB 391	Lieu	Increases size of SCAQMD Board from 12 to 13; new member from a west side city other than LA		Failed passage
AB 444	Hancock	Authorizes Alameda and Contra Costa congestion management agencies to impose an annual \$10 vehicle registration fee surcharge for congestion mitigation		Failed passage
AB 463 *	Huffman	<i>Previously California Clean Ferry Act of 2007; now disabled persons parking measure</i>	BAAQMD Support	N/A
AB 493	Ruskin	Establishes fees and rebates respectively at the time of sale of high and low-emitting new motor vehicles	BAAQMD Support	Failed passage
AB 505	Plescia	Income tax credits for hybrid vehicles		Failed passage
AB 532	Wolk	Requires solar electric installation by 2009 on all state buildings where feasible		Chaptered
AB 534	Smyth	Increases Bicycle Transportation Account funding		Failed passage
AB 568	Karnette	Requires establishment of Port Community Advisory Committees		Failed passage
AB 575	Arambula	Prioritizes Proposition 1B air quality bond funding to South Coast and San Joaquin	BAAQMD Oppose	Failed passage
AB 616	Jones	Requires annual (instead of biennial) smog checks for cars at least 15 years old currently in the program	BAAQMD, MTC Support	Failed passage
AB 619 *	Emmerson	Amnesty for vehicles that committed title fraud (<i>amended to address BAAQMD concerns</i>)	BAAQMD Oppose	Failed passage
AB 630	Price	Requires ARB to submit local district waiver request to EPA		Failed passage
AB 631	Horton	Requires new fueling stations by 2010 to be able to provide ethanol (E-85)		Failed passage
AB 657	Jeffries	Spot bill on greenhouse gas emissions		Failed passage
AB 700	Lieu	ARB study of air pollution from Santa Monica airport		Failed passage
AB 705	Huffman	Requires state regulations for geologic carbon sequestration		Failed passage
AB 712	DeLeon	Bill to provide funding for trash trucks to comply with ARB pending off-road regulations		Failed passage
AB 746	Krekorian	Expedited processing of renewable power plants		Failed passage

AB 747	Levine	Requires ARB to develop regulations to cut carbon in transportation fuels, using market approaches		Failed passage
AB 785	Hancock	Addresses urban heat islands		Vetoed
AB 829	Duvall	Affects after-market motorcycle parts certified by the ARB and their use		Chaptered
AB 842	Jones	States intent to award Prop 1B funds to jurisdictions that have a plan to reduce vehicle miles traveled	MTC, ABAG Oppose	Failed passage
AB 846	Blakeslee	Clean Marine Fuels Tax Incentive Act	BAAQMD Support	Failed passage
AB 934	Duvall	Would prohibit air districts from adopting airborne toxic control measures for non-stationary sources	BAAQMD Oppose	Failed passage
AB 995	Nava	Prop 1B bond funding of trade corridor and air quality improvements		Failed passage
AB 1077	Lieber	California Plug-in Hybrid Electric Vehicle Leadership Act of 2007	BAAQMD Support	Failed passage
AB 1083	Huffman	Tax credits for sale of biodiesel fuel		Failed passage
AB 1094	Arambula	Tax credits for biodiesel vendors		Failed passage
AB 1119	Fuller	Affects ARB requirements for particulate traps		Failed passage
AB 1138	Brownley	Requires ARB to resolve questions regarding local AQMD boundaries		Failed passage
AB 1209 *	Karnette	Establishes health-based criteria for distribution of Prop 1B air quality funds	BAAQMD Oppose	Failed passage
AB 1225	DeSaulnier	Requires guidelines on environmental factors to guide state fleet purchases, and local government fleets of more than 100 vehicles		Failed passage
AB 1455	Arambula	Would establish California Air Quality Zones, and allow loans for entities within these areas		Failed passage
AB 1488	Mendoza	Requires a pilot program to integrate light-duty diesel vehicles into smog check		Chaptered
AB 1613	Blakeslee	Waste Heat and Carbon Emissions Reduction Act		Failed passage
AB 1651	Alarcon	Tax credits for 'green' businesses acquiring 'green' machinery		Failed passage
SB 9	Lowenthal	Criteria for expenditure of trade corridor funds from Prop 1B		Failed passage
SB 19	Lowenthal	Criteria for expenditure of air quality funds from Prop 1B		Failed passage

SB 23	Cogdill	Establishes a SJVUAQMD program to replace gross polluters with donated cleaner vehicles		Chaptered
SB 70	Florez	Establishes standards for biodiesel and biodiesel blends		Vetoed
SB 71	Florez	Requires ARB to administer a program to ensure that diesel vehicles owned by the State, cities, counties, and mass transit districts use B20 biodiesel		Failed passage
SB 72	Florez	Requires ARB to see that diesel schoolbuses (public and private contractors) use B20 biodiesel		Failed passage
SB 73	Florez	Establishes tax credits for producers of biodiesel		Failed passage
SB 74	Florez	Exempts biodiesel from sales tax		Failed passage
SB 75	Florez	Requires state diesel vehicles to be warranted to use B20 biodiesel		Failed passage
SB 140	Kehoe	Requires California diesel to increase its renewable content first to at least 2%, and then to 5%		Failed passage
SB 210	Kehoe	Requires ARB to develop a program to reduce carbon content of California transportation fuels by 10% by 2020, and implement a low-carbon fuel standard		Failed passage
SB 240	Florez	Authorizes SJVUAQMD to increase vehicle registration fee to \$30		Failed passage
SB 494	Kehoe	Requires ARB to adopt a program so that by 2020 half of new vehicles sold use clean alternative fuels		Failed passage
SB 509	Simitian	Requires ARB to adopt regulations to limit formaldehyde emissions from composite wood to EU standards	BAAQMD Support	Failed passage
SB 531	Oropeza	Declares legislative intent to reform regulation of air toxics		Failed passage
SB 532	Oropeza	Spot bill on port air pollution		Failed passage
SB 572	Cogdill	Declares legislative intent to consider carbon emissions from wildfire, and forest carbon sequestration		Failed passage
SB 587	Runner	Establishes exemptions from air district permit requirements for certain printing, coating, adhesive application, and laminating operations, subject to specified criteria	BAAQMD Oppose	Failed passage
SB 613	Simitian	Extends sunset of local San Mateo \$4 vehicle registration fee surcharge from 2009 to 2019		Vetoed
SB 719	Machado	Increases SJVUAQMD Board to 15, with 2 Governor's appointees and 5 city council members		Chaptered

SB 842	Scott	Adds air protective requirements to gasification (conversion of solid waste to fuel)		Failed passage
SB 857	Correa	Authorizes study of tax credits for air pollution reduction equipment in SCAQMD and SJVUAQMD		Failed passage
SB 871	Kehoe	Reestablishes through 2012 the expedited review process for new powerplants		Failed passage
SB 876	Calderon	Requires ARB to consider economic impacts of diesel fleet rules on small businesses		Failed passage
SB 886	Negrete McLeod	Ends term limits for South Coast, Sacramento, and Mojave air district board chairs; increases SCAQMD Board from 12 to 13		Chaptered
SB 974	Lowenthal	Establishes a container fee of \$30 per twenty-foot equivalent unit at LA, Long Beach, and Oakland ports	BAAQMD Support	Failed passage

BAY AREA AIR QUALITY MANAGEMENT DISTRICT
Memorandum

To: Chairperson Wagenknecht and
Members of the Legislative Committee

From: Jack P. Broadbent
Executive Officer/APCO

Date: November 19, 2007

Re: Potential Legislative Proposals for 2008

RECOMMENDED ACTION:

Consider potential legislative proposals, including possible joint legislative action with the Metropolitan Transportation Commission

BACKGROUND

At the November 19, 2007 meeting of the Executive Committee, the Committee recommended exploring sponsoring legislation jointly with the Metropolitan Transportation Commission (MTC) on placing before the voters a regional gasoline fee to help reduce the region's contribution to climate change. This follows a November 9, 2007 meeting of MTC's Legislative Committee where a regional gasoline fee was discussed. MTC's committee had a generally favorable discussion of the idea, and recommended that the full Commission consider the idea as part of its 2008 legislative agenda at its next meeting December 14, 2007. In addition, the Legislative Committee may have additional proposals for critical legislative issues.

DISCUSSION

Two recent Bay Area polls have been conducted asking questions about a regional gas fee and climate change. One was sponsored by the Bay Area Council and the Transportation and Land Use Coalition. Essentially, it found that 55% of likely voters would support a regional gas tax of 10 cents per gallon with the revenues being used to help address climate change. The second poll was funded by the Metropolitan Transportation Commission. It found that 46% of those questioned would be willing to pay 25 cents more per gallon if the money would be used to limit global warming, and an additional 23% would possibly be willing.

The Commission has had statutory authority since 1997 to seek voter approval of a regional gas tax of up to 10 cents per gallon. While taxes require a two-thirds supermajority vote of the public, fees require a simple majority. While much has been written about the differences between a fee and a tax under the California Constitution, in essence fees must have a clear nexus between the payer's activities and the alleged adverse effects addressed by the fee. The fee cannot be levied for unrelated purposes, and the fee amount must bear a reasonable relationship to the burden created by the actions of the fee-payers. The Executive Committee, and MTC's Legislative Committee,

AGENDA : 5

discussed co-sponsoring a bill to change MTC's existing authority to place a gas tax on the ballot to include a gas fee.

The Board has consistently shown leadership in working to address climate change. The consumption of gasoline in motor vehicles in the Bay Area is our largest source of greenhouse gases. There are multiple programs that could cost-effectively cut climate-changing emissions from vehicles if funds were available. Both the Bay Area Council and the Transportation and Land Use Committee have expressed support for the concept, and an interest in working with MTC and the District on such a measure.

The Executive Committee will bring this proposal to the full Board for its consideration at its December 5, 2007 meeting. If endorsed by the Board, staff recommends that sponsoring such legislation jointly with MTC would constitute the bulk of our legislative agenda in 2008. Staff will of course bring all significant air quality bills introduced in 2008 to the Committee for its consideration through the course of the year. If the Legislative Committee identifies other critical legislative proposals for 2008, the Committee will need to provide direction to staff on priorities among the proposals.

BUDGET CONSIDERATION/FINANCIAL IMPACT

None

Respectfully submitted,

Jack P. Broadbent
Executive Officer/APCO

Prepared by: Thomas Addison

BAY AREA AIR QUALITY MANAGEMENT DISTRICT
Memorandum

To: Chairperson, Mark Ross and Members
of the Board of Directors

From: Jack P. Broadbent
Executive Officer/APCO

Date: November 27, 2007

Re: Report of the Public Outreach Committee Meeting of November 26, 2007

RECOMMENDED ACTIONS

Consider recommending Board of Directors' approval of the Cleaner Burning Technology Incentives Program and authorize staff to begin contract discussions with the Hearth Products and Barbeque Association to run the program on behalf of the Air District.

DISCUSSION

The Public Outreach Committee met on Monday, November 26, 2007 to receive the following reports:

- 1) 2007/2008 Spare the Air Tonight Campaign; and
- 2) An update on the Development of Cleaner Burning Technology Incentive Program.

Attached are the staff reports presented in the Public Outreach Committee packet.

Chairperson Klatt will give an oral report of the meeting.

BUDGET CONSIDERATION/FINANCIAL IMPACT

On July 25, 2007, the Board of Directors designated a Reserve for a Cleaner Burning Technology Incentive Program and funded the new Reserve with a transfer of \$500,000 from Undesignated Reserves. Staff will request a transfer of \$300,000 from the designated reserve to the FY 07-08 District budget at the December 12, 2007 Budget and Finance Committee meeting to fund the Cleaner Burning Technology Incentive Program.

Respectfully submitted,

Jack P. Broadbent
Executive Officer/APCO

Prepared by: Mary Romaidis
Reviewed by: Mary Ann Goodley

BAY AREA AIR QUALITY MANAGEMENT DISTRICT

Memorandum

To: Chair Klatt and Members
of the Public Outreach Committee

From: Jack P. Broadbent
Executive Officer/APCO

Date: November 16, 2007

Re: 2007/2008- Spare the Air Tonight Outreach Campaign

RECOMMENDED ACTION

For information only.

BACKGROUND

Staff will present a summary of the Air District's wintertime outreach campaign. The campaign began on November 13, 2007 and runs through February 11, 2008.

DISCUSSION

The US EPA adopted more stringent Particulate Matter (PM_{2.5}) standards last September, lowering the national 24-hour standard from 65 micrograms/m³ down to 35 micrograms/m³. Last winter, the District issued a total of 30 Spare the Air Tonight advisories. Preliminary monitoring data reported 27 exceedances of the revised national 24-hour health-based PM_{2.5} standard.

This season, the Public Information Office is conducting outreach efforts to increase public awareness about the sources of wintertime air pollution and to promote the clean air choices individuals can make to reduce emissions. The kick-off of this year's campaign also coincided with community outreach meetings held throughout the Bay Area to discuss the draft rule to reduce wood smoke. Later this season, the campaign will also incorporate promotion of the 2008 woodstove/fireplace change-out program.

Media and Outreach Strategy:

Staff will conduct wintertime outreach through local broadcast and print media, community events, and distribution of associated "Spare the Air Tonight" educational materials including:

- Media advisories for Spare the Air Nights, as well as press releases issued before holidays and other key points in the season.
- Paid advertisements and public service announcements on television, radio, and in-theatre that encourage residents to refrain from burning wood.
- Distributing "Spare the Air Tonight" print materials
- Workshops and community events throughout the region.

Staff will present the radio and television advertisements for this season at the committee meeting.

Surveys

Surveys will be conducted on nights when a Spare the Air Tonight advisory is issued. The purpose of these surveys is to gauge the public's attitude and behavior with respect to burning wood, to measure their awareness of the Spare the Air Tonight Program, and to estimate the impact that the Program has had on awareness, opinions and behavior relevant to particulate matter, burning wood, and air quality.

Other

The Spare the Air web page – www.sparetheair.org – has been updated to reflect the winter program. Staff will continue to work with the more than 1,500 employers in the Spare the Air Employer program.

BUDGET CONSIDERATIONS/FINANCIAL IMPACT

Funding for the outreach program was included in the 2007-08 budget.

Respectfully submitted,

Jack P. Broadbent
Executive Officer/APCO

Prepared by: Karen M. Schkolnick
Reviewed by: Jean Roggenkamp

BAY AREA AIR QUALITY MANAGEMENT DISTRICT

Memorandum

To: Chair Klatt and Members
of the Public Outreach Committee

From: Jack P. Broadbent
Executive Officer/APCO

Date: November 19, 2007

Re: Cleaner Burning Technology Incentive Program Development

RECOMMENDED ACTION

Recommend Board of Directors' approval of the Cleaner Burning Technology Incentives Program and authorize staff to begin contract discussions with Hearth Products and Barbeque Association to run the program on behalf of the Air District.

BACKGROUND

Wood smoke generated from 1.1 million homes in the Bay Area is a large source of fine particulate matter (PM_{2.5}). Air District research indicates that fine particulate matter from wood smoke comprises upward of 30% of the peak PM_{2.5} levels during the winter months of November through February. As the Air District likely will be non-attainment for the 24-hour PM_{2.5} National Ambient Air Quality Standard, reductions in wood smoke emissions will be necessary to achieve clean air in the San Francisco Bay Area. A regulation will be considered in early 2008 to require mandatory curtailment of wood burning when the District predicts unhealthy air quality during the winter months. In order to obtain additional wood smoke reductions on an ongoing basis, Air District staff is proposing a financial incentive program to encourage the replacement of high emitting fireplaces and old wood stoves with more modern, EPA certified devices and natural gas fueled devices.

DISCUSSION

Cleaner burning technology promoted through a "Wood Stove Change-out" program will provide Bay Area residents with financial incentives ranging from \$300 to \$600 to upgrade their current wood burning devices and fireplaces. Conventional fireplaces and uncertified wood stoves emit significantly more PM_{2.5} than low emission EPA certified devices and natural gas fired devices and pellet stoves. (See Figure 1.)

Figure 1: Comparison of PM2.5 Emission Rates

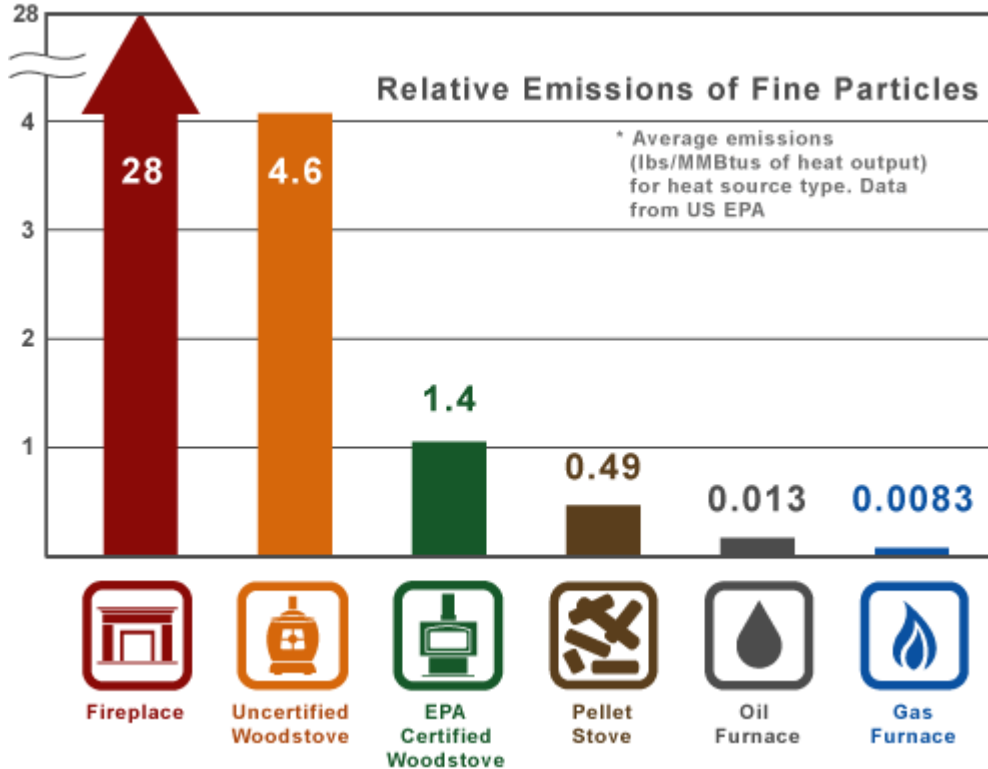

In order to reduce wood smoke PM_{2.5} emissions in the Bay Area, the Air District is proposing a financial incentive program to encourage the change-out of dirty technology for newer, low emission technology. Staff has examined PM_{2.5} emissions rates, energy efficiency, green house gas impacts, and random telephone survey results¹ as factors in setting the incentive amounts. The amounts shown in Table 2 are to convert from either a conventional fireplace or an older, non-EPA certified wood burning device to a cleaner burning technology.

Table 2: Cleaner Burning Technology Incentive Amounts

Device	Incentive	PM Emissions Reductions Rating	Green House Gas Neutrality Rating	Heat Efficiency Rating
EPA Certified Pellet Stove or Insert	\$600	GOOD	VERY GOOD	VERY GOOD
Gas Fired Stove or Insert	\$600	VERY GOOD	FAIR	VERY GOOD
EPA Certified Wood Stove or Insert	\$300	FAIR	GOOD	VERY GOOD
Gas Fired Log Set	\$300	VERY GOOD	FAIR	POOR

¹ Random telephone survey results for 2006 & 2007 indicated that 22% of the respondents would be willing to voluntary upgrade to a cleaner wood burning device if a \$500.00 incentive were offered.

AGENDA: 5

The initial incentive amounts listed in Table 2 were developed based on other similar incentive programs in California and the Air District's own, limited change-out programs. The incentive amounts may need to be adjusted in the future in order to stimulate demand on the part of the public.

Staff is proposing to implement the incentives through a contract with the Hearth, Patio and Barbeque Association (HPBA) similar to the mechanism used for the Air District's Vehicle Buy Back Program. The HPBA has handled manufacturer and dealer side incentive programs for Sacramento, San Joaquin, Shasta County, and Yolo-Solano air districts' wood stove change-out programs. The organization is very familiar with both the procedural requirements and the documentation for destruction of the replaced wood burning appliance. Additionally, HPBA has handled the Western Propane Gas Association program that was a \$300 rebate program for new and remodeled propane gas hearth installations for a total of \$40,000 in 2007.

Staff is still developing incentive programs for "do-it-yourself" installations and situations where conventional fireplaces or uncertified wood stoves are completely removed from service. Staff proposes to bring forward those program details at a future Public Outreach Committee meeting.

BUDGET CONSIDERATIONS/FINANCIAL IMPACT

On July 25, 2007, the Board of Directors designated a Reserve for a Cleaner Burning Technology Incentive Program and funded the new Reserve with a transfer of \$500,000 from Undesignated Reserves. Staff will request a transfer of \$300,000 from the designated reserve to the FY07-08 District budget at the December 12, 2007 Budget and Finance Committee meeting to fund the Cleaner Burning Technology Incentive Program.

Respectfully submitted,

Jack P. Broadbent
Executive Officer/APCO

Prepared by: Jean Roggenkamp, Kelly Wee

BAY AREA AIR QUALITY MANAGEMENT DISTRICT
Memorandum

To: Chairperson Mark Ross and Members
of the Board of Directors

From: Jack P. Broadbent
Executive Officer/APCO

Date: November 28, 2007

Re: Report of the Stationary Source Committee Meeting of December 3, 2007

RECOMMENDED ACTION

Receive and file.

BACKGROUND

The Stationary Source Committee will meet on Monday, December 3, 2007.

The Committee will receive the following presentations:

- A) Status Report on Proposed Regulation 6; Rule 2: Commercial Cooking Equipment.
- B) Status Report on Wood Smoke

Attached are the staff reports presented in the Stationary Source Committee packet for your review.

Chairperson, Scott Haggerty will give an oral report of the meeting.

BUDGET CONSIDERATION/FINANCIAL IMPACT

None.

Respectfully submitted,

Jack P. Broadbent
Executive Officer/APCO

Prepared by: Mary Romaidis
Approved by: Mary Ann Goodley

BAY AREA AIR QUALITY MANAGEMENT DISTRICT

Memorandum

To: Chairperson Haggerty and Members
of the Stationary Source Committee

From: Jack P. Broadbent
Executive Officer/APCO

Date: November 20, 2007

Re: Proposed Regulation 6, Rule 2: Commercial Cooking Equipment

RECOMMENDED ACTION:

Receive and file.

BACKGROUND

On May 16, 2007, the Board of Directors conducted a public hearing to consider adoption of proposed Regulation 6, Rule 2: Commercial Cooking Operations. The Board referred the item to the Stationary Source Committee for further discussion. Staff conducted a survey to gain further data on the number, size, and type of charbroilers operated in restaurants within the District and types and amounts of meats cooked. Based on analysis of the survey results, staff revised the proposed rule and conducted a public workshop on October 23, 2007. Staff has addressed the public comments received during and following the workshop. A public hearing is scheduled on the proposed rule for December 5, 2007.

DISCUSSION

In this report, Staff will present information on:

- Background;
- Proposed Regulation 6, Rule 2;
- October 23, 2007 workshop comments and responses; and
- Next steps in the rule development process.

BUDGET CONSIDERATIONS/FINANCIAL IMPACT:

None.

Respectfully submitted,

Jack P. Broadbent
Executive Officer/APCO

Prepared by: Virginia Lau
Reviewed by: Henry Hilken

BAY AREA AIR QUALITY MANAGEMENT DISTRICT
Memorandum

To: Chairperson Haggerty and Members
of the Stationary Source Committee

From: Jack P. Broadbent
Executive Officer/APCO

Date: November 20, 2007

Re: Status Update on the Wood Smoke Rule Development

RECOMMENDED ACTION:

Receive and file.

BACKGROUND

Last winter, the District experienced 27 days over the new $35 \mu\text{g}/\text{m}^3$ 24-hr $\text{PM}_{2.5}$ National Ambient Air Quality Standard (NAAQS) that was adopted by U.S. EPA in December 2006. Ambient air monitoring results indicate that wood smoke contributes up to 33% of peak winter $\text{PM}_{2.5}$ levels.

On September 10, 2007, proposed Regulation 6, Rule 3, "Wood-Burning Devices", and Cleaner Burning Technology Incentives Program was presented to the Committee. Since that date, Staff has completed the draft rule and conducted seven (7) public workshops at locations in Oakland, Santa Rosa, San Jose, Concord, Vallejo, Redwood City and Livermore. The Air District is continuing to receive comments and feedback on the draft regulation until December 10, 2007.

DISCUSSION

Staff will provide the Committee with the following information:

- Review of proposed new Regulation 6, Rule 3: Wood-Burning Devices;
- Summary of the public workshop comments and responses; and
- Next steps in the rule development process

Respectfully submitted,

Jack P. Broadbent
Executive Officer/APCO

Prepared by: Paul Hibser
Reviewed by: Kelly Wee

BAY AREA AIR QUALITY MANAGEMENT DISTRICT
Memorandum

To: Chairperson Mark Ross
and Members of the Board of Directors

From: Jack P. Broadbent
Executive Officer/APCO

Date: November 28, 2007

Re: Report of the Nominating Committee Meeting of December 5, 2007

RECOMMENDED ACTION

Approve Committee recommendation of Board Officers for the 2008 term of office.

BACKGROUND

The Nominating Committee will meet on Wednesday, December 5, 2007. The Committee will discuss the nomination of Board Officers for 2008. The Committee will recommend Board of Directors' election of the 2008 slate of Board Officers.

Chairperson Mark Ross will give an oral report of the meeting. Attached is the staff report presented in the Nominating Committee packet for your review.

BUDGET CONSIDERATION/FINANCIAL IMPACT

None.

Respectfully submitted,

Jack P. Broadbent
Executive Officer/APCO

Prepared by: Mary Ann Goodley

BAY AREA AIR QUALITY MANAGEMENT DISTRICT
Memorandum

To: Chairperson Mark Ross and Members
of the Board of Directors

From: Jack P. Broadbent
Executive Officer/APCO

Date: November 27, 2007

Re: Public Hearing to Consider Adoption of Proposed Regulation 6, Rule 2:
Commercial Cooking Equipment, Adoption of Proposed Amendments to
Regulation 6: Particulate Matter and Visible Emissions, and Regulation 3:
Fees, and Adoption of CEQA Negative Declaration

RECOMMENDED ACTION:

Staff recommends that the Board of Directors take the following actions:

- Adopt proposed Regulation 6, Rule 2: Commercial Cooking Equipment;
- Adopt proposed amendments to Regulation 6: Particulate Matter and Visible Emissions;
- Adopt proposed amendments to Regulation 3: Fees; and,
- Adopt a California Environmental Quality Act (CEQA) Negative Declaration.

BACKGROUND

Charbroiling produces an estimated 6.9 tons of particulate matter (PM) and 1.1 tons of organic compounds per day in the Bay Area. Several studies conducted by the University of California Riverside and the University of Minnesota indicate that charbroilers are responsible for over 80% of particulate matter and organic emissions from commercial cooking. Proposed Regulation 6, Rule 2: Commercial Cooking Equipment will fulfill the District's commitment to control restaurant emissions under the Senate Bill 656 Particulate Matter Implementation Schedule and implement potential controls proposed for evaluation in further study measure FS-3 from the Bay Area 2005 Ozone Strategy.

Proposed Regulation 6, Rule 2 was presented to the Board of Directors at a public hearing held on May 16, 2007. The Board referred the proposed regulation to the Stationary Source Committee for additional review. Staff conducted a survey of Bay Area restaurants to gain further data on the number, sizes, and types of charbroilers within the District and types and amounts of meats cooked. Based on the results of the survey and additional research, staff revised the proposed rule and conducted a public workshop on October 23, 2007.

DISCUSSION

Proposed Regulation 6, Rule 2 would regulate restaurant charbroiler emissions of PM₁₀ (particulate matter of 10 microns or less) and organic compounds. The proposed rule would require:

1. PM₁₀ and organic emissions from chain-driven (conveyorized) charbroilers at restaurants that purchase at least 500 pounds (lbs.) of beef per week and cook at least 400 lbs. of beef per week on the charbroiler to be controlled by a catalytic oxidizer or equivalent control. This requirement would become effective January 1, 2009.
2. Under-fired charbroilers with an aggregate grill surface area of ten square feet or more at restaurants that purchase at least 1,000 lbs. of beef per week and charbroil at least 800 lbs. of beef per week to be controlled by a control device certified to emit no more than 1.0 lbs. of PM₁₀ per 1,000 lbs. of beef cooked. This requirement would become effective January 1, 2010 for restaurants with an under-fired charbroiler installed on or after January 1, 2010. Effective January 1, 2013, the requirement would apply regardless of the installation date of an under-fired charbroiler.
3. Owners or operators of chain-driven and under-fired charbroilers subject to the control requirements of proposed Regulation 6, Rule 2 would be required to register their equipment and control devices with the District. The owner or operator would pay a registration fee of \$360 and an annual fee of \$100.

The most significant change to the proposal from the May 2007 draft is that the rule would only apply to restaurants that grill a significant quantity of beef on a charbroiler. When charbroiled, beef emits about three times more particulate matter per pound than any other meat. The rule is focused on the highest volume, highest emitting restaurants. The rule will affect about 600 restaurants and will reduce emissions by 72% from affected restaurants.

A socioeconomic analysis has found that the costs of the rule would not create significant economic dislocation or loss of jobs, including to small businesses. Pursuant to the California Environmental Quality Act (Public Resources Code 21000 et seq.), an initial study for the proposed amendments has been conducted, concluding that the proposed rule would not create significant adverse environmental impacts. A Negative Declaration was posted for public review and comment, and no comments were received.

In June 2007, the Board adopted Regulation 3: Schedule R: Equipment Registration Fees. The proposed amendments reduce the fees because the current proposed rule is somewhat less costly to administer and implement than the version proposed on May 16, 2007.

Regulation 6: Particulate Matter and Visible Emissions would be renamed and renumbered to Regulation 6: Particulate Matter, Rule 1: General Requirements. The changes do not alter the substance of this rule.

The South Coast test protocol for determining emissions from chain-driven charbroilers is referred to in Regulation 6, Rule 2 and included in the Board package for reference.

RULE DEVELOPMENT PROCESS

Proposed Regulation 6, Rule 2 is the result of an intensive rule development process dating back to 2005. Staff worked with hood manufacturers, industry representatives, restaurant operators, and county health departments. Staff conducted four public workshops in November 2006 on an initial draft rule. After the November workshops, staff received several comment letters and engaged in discussions with hood manufacturers and industry representatives to refine the proposed rule. Staff published a second draft in February 2007 and hosted a workshop in March 2007. Comments were then incorporated into a proposed rule presented to the Board at a May 16, 2007 public hearing.

At the public hearing, the Board referred the draft rule to the Stationary Source Committee. Staff then conducted a survey of restaurants in the Bay Area to determine the typical size of restaurant charbroiler grills and the types and amounts of meat restaurants cook on charbroilers. Based on the results of the survey and follow-on discussions with restaurant associations, staff revised the draft rule and presented the revised rule at a public workshop on October 23, 2007. Staff has responded to comments received during and following the public workshop and made changes to the rule, as necessary. Staff has also met with and discussed the rule with the Golden Gate Restaurant Association, the California Restaurant Association, San Francisco Building Code Advisory Committee, California Environmental Health Association, PG&E Food Service Technology Center, American Society of Heating, Refrigeration, and Air-Conditioning Engineers (ASHRAE) and county health departments.

The final proposed rule, public hearing notice, staff report, socio-economic analysis, CEQA initial study analysis and negative declaration, the South Coast protocol for testing emissions from chain-driven charbroilers, and the proposed amendments to Regulation 3 and Regulation 6 were posted for public review on November 5, 2007. Five comments have been received. These comments do not necessitate changes to the proposal. Comments and responses are included as Appendix C to the staff report.

BUDGET CONSIDERATION/FINANCIAL IMPACTS

Operating costs to administer and enforce the new rule will be recovered by registration fees set out in proposed Regulation 3 Fees, Schedule R: Commercial Cooking Equipment.

Respectfully submitted,

Jack P. Broadbent
Executive Officer / APCO

Prepared by: Virginia Lau
Reviewed by: Henry Hilken

Attachments:

Proposed Regulation 6, Rule 2: Commercial Cooking Equipment

Proposed amendments to Regulation 6: Particulate Matter and Visible Emissions

Proposed amendments to Regulation 3: Fees, Schedule R: Equipment Registration Fees

Staff Report including appendices

Appendix A: Emission Calculations

Appendix B: South Coast Air Quality Management District's Protocol, "Determination of Particulate and Volatile Organic Compound Emissions from Restaurant Operations," November 14, 1997

Appendix C: Responses to Comments

Appendix D: Socioeconomic Analysis

Appendix E: CEQA Initial Study and Negative Declaration

**REGULATION 6
PARTICULATE MATTER
RULE 2
COMMERCIAL COOKING EQUIPMENT**

INDEX

6-2-100 GENERAL

- 6-2-101 Description
- 6-2-102 Applicability
- 6-2-110 Exemption, Low Utilization of Chain-driven Charbroiler
- 6-2-111 Exemption, Low Utilization of Under-fired Charbroiler

6-2-200 DEFINITIONS

- 6-2-201 Beef
- 6-2-202 Catalytic Oxidizer
- 6-2-203 Chain-driven (Conveyorized) Charbroiler
- 6-2-204 Charbroiler
- 6-2-205 Grill Surface Area
- 6-2-206 Organic Compounds
- 6-2-207 Particulate Matter
- 6-2-208 PM₁₀
- 6-2-209 Restaurant
- 6-2-210 Under-fired Charbroiler

6-2-300 STANDARDS

- 6-2-301 Chain-Driven Charbroilers
- 6-2-302 New Installation of Under-Fired Charbroilers
- 6-2-303 Existing Under-Fired Charbroilers
- 6-2-304 Control Equipment Maintenance

6-2-400 ADMINISTRATIVE REQUIREMENTS

- 6-2-401 Registration for Chain-Driven Charbroiler
- 6-2-402 Registration for Under-Fired Charbroiler
- 6-2-403 Emission Control Equipment Compliance
- 6-2-404 Application for Certification

6-2-500 MONITORING AND RECORDS

- 6-2-501 Recordkeeping Regarding Chain-Driven Charbroilers
- 6-2-502 Recordkeeping Regarding Under-Fired Charbroilers
- 6-2-503 Retention of Records

6-2-600 MANUAL OF PROCEDURES

- 6-2-601 Determination of Emissions from Catalytic Oxidizers
- 6-2-602 Determination of Emissions from Chain-Driven Charbroilers
- 6-2-603 Determination of Emissions from Under-Fired Charbroilers

**REGULATION 6
PARTICULATE MATTER
RULE 2
COMMERCIAL COOKING EQUIPMENT**

6-2-100 GENERAL

6-2-101 Description: The purpose of this rule is to reduce emissions from commercial cooking equipment.

6-2-102 Applicability: This rule shall apply to any person who either:

102.1 Owns, operates, or installs a chain-driven (conveyorized) charbroiler in a restaurant that is located within the District and that purchases 500 pounds of beef or more per week; or

102.2 Owns, operates, or installs an under-fired charbroiler in a restaurant that is located within the District and that purchases 1,000 pounds of beef or more per week.

6-2-110 Exemption, Low Utilization of Chain-driven Charbroiler: The requirements of this rule shall not apply to any person who operates a chain-driven charbroiler in a restaurant that grills less than 400 pounds of beef per week on the chain-driven charbroiler, provided the person maintains records that demonstrate the restaurant grills less than 400 pounds of beef per week on the chain-driven charbroiler.

6-2-111 Exemption, Low Utilization of Under-fired Charbroiler: The requirements of this rule shall not apply to any person who operates an under-fired charbroiler in a restaurant that grills less than 800 pounds of beef per week on the under-fired charbroiler, provided the person maintains records that demonstrate the restaurant grills less than 800 pounds of beef per week on the under-fired charbroiler.

6-2-200 DEFINITIONS

6-2-201 Beef: All steaks, hamburger, and other meat products from an adult domestic bovine, including any attached bone, tendons, fat, and organs.

6-2-202 Catalytic Oxidizer: An emission control device that employs a catalyst fixed onto a substrate to oxidize air contaminants in an exhaust stream, thereby converting the air contaminants into carbon dioxide and water.

6-2-203 Chain-driven (Conveyorized) Charbroiler: A semi-enclosed charbroiler designed to mechanically move food on a grated grill through the broiler.

6-2-204 Charbroiler: A cooking device composed of a grated grill and a heat source, where food resting on the grated grill cooks as the food receives direct heat from the heat source or a radiant surface.

6-2-205 Grill Surface Area: The area of the cooking surface on the grill of a charbroiler.

6-2-206 Organic Compounds: Any organic compounds of carbon, excluding methane, carbon monoxide, carbonic acid, metallic carbides or carbonates and ammonium carbonate.

6-2-207 Particulate Matter: Any finely divided solid or liquid airborne material.

6-2-208 PM₁₀: Particulate matter with an aerodynamic diameter that is less than or equal to a nominal 10 microns.

6-2-209 Restaurant: Any stationary facility that cooks food for human consumption and that engages in the retail sale, or offer for sale, of the cooked food. This includes, but is not limited to, dinner houses, cafeterias, catering operations, and hotel or motel food service operations.

6-2-210 Under-fired Charbroiler: A charbroiler, other than a chain-driven charbroiler, where the heat source and radiant surface, if any, are positioned at or below the level of the grated grill.

6-2-300 STANDARDS

6-2-301 Chain-Driven Charbroilers:

301.1 Effective January 1, 2009, no person shall operate a chain-driven charbroiler unless it is equipped and operated with a catalytic oxidizer certified pursuant to Sections 6-2-403 and 6-2-404 for use in combination with the specific model of chain-driven charbroiler by limiting the PM₁₀ and organic compound emissions to no more than 1.3 pounds of PM₁₀ and 0.32 pounds of organic compounds per 1,000 pounds of beef cooked.

301.2 Notwithstanding Section 6-2-301.1, a person may operate a chain-driven charbroiler with a control device certified pursuant to Sections 6-2-403 and 6-2-404 as limiting the PM₁₀ emissions of the chain-driven charbroiler to no more than 0.74 pounds of PM₁₀ per 1,000 pounds of beef cooked.

6-2-302 New Installation of Under-Fired Charbroilers: In any restaurant that contains one or more under-fired charbroilers installed on or after January 1, 2010 such that the under-fired charbroilers in the restaurant have an aggregate grill surface area of ten (10) square feet or more:

302.1 Under-Fired Charbroilers: No person shall operate any under-fired charbroiler unless emissions from the under-fired charbroiler are exhausted through a control device certified pursuant to Sections 6-2-403 and 6-2-404 as limiting the PM₁₀ emissions of the under-fired charbroiler to no more than 1.0 pounds of PM₁₀ per 1000 pounds of beef cooked.

6-2-303 Existing Under-Fired Charbroilers: Effective January 1, 2013, no person shall operate an under-fired charbroiler in any restaurant that contains one or more under-fired charbroilers with an aggregate grill surface area of ten (10) square feet or more, unless emissions from each under-fired charbroiler are exhausted through a control device certified pursuant to Sections 6-2-403 and 6-2-404 as limiting the PM₁₀ emissions of the under-fired charbroiler to no more than 1.0 pounds of PM₁₀ per 1000 pounds of beef cooked.

6-2-304 Control Equipment Maintenance: Any emission control device installed and/or operated under this rule shall be operated, cleaned, and maintained in accordance with the manufacturer's specifications.

6-2-400 ADMINISTRATIVE REQUIREMENTS

6-2-401 Registration for Chain-Driven Charbroiler: Effective January 1, 2009, any person operating any chain-driven charbroiler subject to the control requirements of Section 6-2-301 shall register the charbroiler and any emission control device that operates with the charbroiler in accordance with Regulation 1, Section 410. Any person registering a charbroiler shall pay the fees required, as set forth in Regulation 3.

6-2-402 Registration for Under-Fired Charbroilers: Effective January 1, 2010, the owner or operator of any restaurant that contains one or more under-fired charbroilers installed on or after January 1, 2009 subject to the control requirements of Section 6-2-302 shall register the under-fired charbroiler(s) and any emission control device(s) that operates with the charbroiler(s) in accordance with Regulation 1, Section 410. Effective January 1, 2013, the owner or operator of any restaurant that contains one or more under-fired charbroilers subject to the control requirements of Section 6-2-303 shall register the under-fired charbroiler(s) and any emission control device(s) that operates with the charbroiler(s) in accordance with Regulation 1, Section 410. Any person registering a charbroiler shall pay the fees required, as set forth in Regulation 3.

6-2-403 Emission Control Equipment Compliance: The manufacturer shall obtain confirmation from an independent testing laboratory that the emission control equipment the manufacturer seeks to sell for use to comply with this rule has been tested in accordance with the applicable procedure in either Section 6-2-601, 6-2-602, or 6-2-603. Catalytic oxidizers certified, at the time the rule is adopted, for use

by the South Coast Air Quality Management District shall be deemed certified for the purposes of this rule.

6-2-404

Application for Certification:

404.1 Each manufacturer shall submit an application to the APCO for certification of their compliant control equipment. The application must:

404.1.1 Provide the following general information: name and address of manufacturer, brand name, trade name, model number, any accoutrements installed to enhance or support the operation of the control equipment, and state operation conditions including the maximum air flow rate.

404.1.2 Provide a description of the model being certified

404.1.3 Include one or more of the following: a complete certification source test report demonstrating that the control equipment was tested in accordance with procedures in Section 6-2-601 and a written statement that the model complies with Sections 6-2-301.1; or a complete certification source test report demonstrating that the control equipment was tested in accordance with procedures in Section 6-2-602 and a written statement that the model complies with Section 6-2-301.2; or a complete certification source test report demonstrating that the control equipment was tested in accordance with procedures in Section 6-2-603 and a written statement that the model complies with Section 6-2-302 or 6-2-303.

404.1.5 Be submitted to the District no more than 90 days after the date of the emissions compliance test conducted in accordance with Section 6-2-403.

404.2 After completing review of the application for certification and source test report, the APCO will approve, or will deny approval of the application.

6-2-500

MONITORING AND RECORDS

6-2-501

Recordkeeping Regarding Emission Control Equipment for Chain-Driven Charbroilers: The owner or operator of a chain-driven charbroiler subject to the control requirements of Section 6-2-301 shall maintain on the premises of the restaurant records of each of the following:

501.1 The date of installation of any emission control device installed to abate emissions from the chain-driven charbroiler.

501.2 All maintenance, including, but not limited to, preventative maintenance, breakdown repair, and cleaning, performed on the emission control device. The records shall include the date, time, and a brief description of the work.

6-2-502

Recordkeeping Regarding Emission Control Equipment for Under-Fired Charbroilers: The owner or operator of a restaurant that contains one or more under-fired charbroilers subject to the control requirements of Section 6-2-302 or 303 shall maintain on the premises of the restaurant record of each of the following:

502.1 The date any control device was initially installed in the restaurant.

502.2 The date any under-fired charbroiler was installed in the restaurant, if installed on or after January 1, 2008.

502.3 All maintenance, including, but not limited to, preventative maintenance, breakdown repair, and cleaning, performed on the emission control device. The records shall include the date, time, and a brief description of the work.

6-2-503

Retention of Records: The owner or operator shall maintain all records required under Sections 6-2-501 or 6-2-502 for a period of not less than five (5) years and shall make the records available to the APCO upon request.

6-2-600 MANUAL OF PROCEDURES

6-2-601 Determination of Emissions from Catalytic Oxidizers: Approval of abatement equipment pursuant to Section 6-2-403 as complying with the standards specified in Section 6-2-301.1 shall be determined in accordance with South Coast Air Quality Management District Protocol "Determination of Particulate and Volatile Organic Compound Emissions from Restaurant Operations", dated November 14, 1997.

6-2-602 Determination of Emissions from Chain-Driven Charbroilers: Approval of abatement equipment pursuant to Section 6-2-403 as complying with the standards specified in Section 6-2-301.2 shall be determined using the following procedures:

602.1 Laboratory testing shall be performed on a control device that is installed per manufacturer's specification above a conveyORIZED charbroiler fueled by natural gas. The testing shall be conducted in accordance with the most recent version of ASTM Standard Test Method F 2239. If the control device is installed after a hood, clean grease baffles shall be installed in the hood prior to testing. The broiler shall be positioned such that a minimum of six (6) inches is maintained between the edge of the hood and the vertical plane of the front and sides of the appliance. Both sides of the broiler shall be a minimum of three (3) feet from any side wall, side partition, or other operating appliance. The velocity of the duct shall correspond to a flow rate of 300 cubic feet per minute (cfm) for each linear foot of hood length. The broiler's temperature controls shall be set at manufacturer's recommended setting for a minimum of 60 minutes prior to testing.

602.2 Pure beef, finished grind hamburgers of 0.33 lbs each shall be cooked on the under-fired charbroiler during testing. The patties shall consist of 18-22% fat by weight and 58-62% moisture. The patties shall be shaped into 0.625 inch thick round patties of five (5) inch diameter. The fat and moisture content of the patties shall be verified in accordance with the laboratory procedures set forth in the Association of Official Analytical Chemists Official Actions 960.39 and 950.46.

602.3 Hamburger patties shall be loaded, cooked, and removed in accordance with Section 10 of ASTM test method F2239-03, or in the analogous provision of the most recent version of ASTM Standard Test Method F 2239, for heavy load conditions.

602.4 Testing shall be performed following EPA Method 5 front half only. During each test, samples shall be collected from the outlet of the control.

6-2-603 Determination of Emissions from Under-Fired Charbroilers: Approval of abatement equipment pursuant to Section 6-2-403 as complying with the standards specified in Sections 6-2-302.1 and 6-2-303 shall be determined using the following procedures:

603.1 Laboratory testing shall be performed on a control device that is installed following manufacturer's specification above an under-fired charbroiler fueled by natural gas that has a grill size of ten square feet or more. The charbroiler shall be operated in accordance with the most recent version of ASTM Standard Test Method F 1695. If the control device is installed after the hood, clean grease baffles shall be installed in the hood prior to testing. The velocity of the duct shall correspond to a flow rate of 400 cubic feet per minute (cfm) for each linear foot of hood length. The hood shall extend over the surface of the under-fired charbroiler by at least six (6) inches in the front and sides. The broiler shall be warmed up for a minimum of 30 minutes prior to testing and operate at a maximum temperature of 600 degrees Fahrenheit, as measured at the center of each location where the meat shall be cooked.

603.2 Pure beef, finished grind hamburgers of 0.33 lbs each shall be cooked on the under-fired charbroiler during testing. The patties shall consist of 18-22% fat by weight and 58-62% moisture. The patties shall be shaped into 0.625 inch thick round patties of five (5) inch diameter. The fat and moisture content of

the patties shall be verified in accordance with the laboratory procedures set forth in the Association of Official Analytical Chemists Official Actions 960.39 and 950.46.

- 603.3** Hamburger patties shall be loaded, cooked, and removed in accordance with Section 10 of ASTM test method F1695-03, or in the analogous provision of the most recent version of ASTM Standard Test Method F 1695, for heavy load conditions. Testing shall begin once the first patty is placed on the broiler and continue for a minimum of 60 minutes, with the end of sampling corresponding to the end of the cooking cycle.
- 603.4** Testing shall be performed following EPA Method 5 front half only. During each test, samples shall be collected from the outlet of the control.

REGULATION 6
PARTICULATE MATTER AND VISIBLE EMISSIONS
RULE 1
GENERAL REQUIREMENTS

INDEX

6-1-100 GENERAL

- 6-1-101 Description
- 6-1-110 Exemption, Temporary Sandblasting Operations
- 6-1-111 Exemption, Open Outdoor Fires

6-1-200 DEFINITIONS

- 6-1-201 Exhaust Gas Volume
- 6-1-202 Particulate Matter
- 6-1-203 Process Weight
- 6-1-204 Process Weight Rate

6-1-300 STANDARDS

- 6-1-301 Ringelmann No. 1 Limitation
- 6-1-302 Opacity Limitation
- 6-1-303 Ringelmann No. 2 Limitation
- 6-1-304 Tube Cleaning
- 6-1-305 Visible Particles
- 6-1-306 Diesel Pile Driving Hammers
- 6-1-310 Particulate Weight Limitation
- 6-1-311 General Operations
- 6-1-320 Sulfuric Acid Manufacturing Plants
- 6-1-330 Sulfur Recovery Units

6-1-400 ADMINISTRATIVE REQUIREMENTS

- 6-1-401 Appearance of Emissions

6-1-500 MONITORING AND RECORDS

- 6-1-501 Sampling Facilities and Instruments Required
- 6-1-502 Data, Records and Reporting
- 6-1-503 Records

6-1-600 MANUAL OF PROCEDURES

- 6-1-601 Particulate Matter, Sampling, Sampling Facilities, Opacity Instruments and Appraisal of Visible Emissions

REGULATION 6
PARTICULATE MATTER AND VISIBLE EMISSIONS
RULE 1
GENERAL REQUIREMENTS

6-1-100 GENERAL

6-1-101 Description: The purpose of this Regulation is to limit the quantity of particulate matter in the atmosphere through the establishment of limitations on emission rates, concentration, visible emissions and opacity.

6-1-110 Exemption, Temporary Sandblasting Operations: Temporary Sandblasting operations are exempt from the provisions of this Rule. Such operations are subject to the provisions of Regulation 12, Rule 4. (Adopted July 11, 1990)

6-1-111 Exemption, Open Outdoor Fires: The limitations of this rule shall not apply to emissions arising from open outdoor fires. (Adopted December 19, 1990)

6-1-200 DEFINITIONS

6-1-201 Exhaust Gas Volume: The volume of gases discharged from an operation; or an emission point.

6-1-202 Particulate Matter: Any material which is emitted as liquid or solid particles, or gaseous material which becomes liquid or solid particles at the testing temperatures specified in the Manual of Procedures, excluding uncombined water.

6-1-203 Process Weight: The total weight of all material introduced into an operation, excluding liquids and gases used solely as fuels, air which is not consumed as a reactant, and combustion air.

6-1-204 Process Weight Rate: A rate established as follows:

204.1 For continuous or long-run steady-state operations, the total process weight for the entire period of continuous operation or for a typical portion thereof, divided by the number of hours of such period or portions thereof.

204.2 For cyclical or batch operations, the total process weight for a period which covers a complete operation or an integral number of cycles, divided by the hours of actual process operation during such period. Where the nature of any process or operation or the design of any equipment is such as to permit more than one interpretation of this section, that interpretation which results in the minimum value for allowable emission shall apply.

6-1-300 STANDARDS

6-1-301 Ringelmann No. 1 Limitation: Except as provided in Sections 6-1-303, 6-1-304 and 6-1-306, a person shall not emit from any source for a period or periods aggregating more than three minutes in any hour, a visible emission which is as dark or darker than No. 1 on the Ringelmann Chart, or of such opacity as to obscure an observer's view to an equivalent or greater degree. (Amended July 11, 1990)

6-1-302 Opacity Limitation: Except as provided in Sections 6-1-303, 6-1-304 and 6-1-306, a person shall not emit from any source for a period or periods aggregating more than three minutes in a any hour an emission equal to or greater than 20% opacity as perceived by an opacity sensing device, where such device is required by District regulations.

(Amended July 11, 1990)

6-1-303 Ringelmann No. 2 Limitation: A person shall not emit for a period or periods aggregating more than three minutes in any hour, a visible emission which is as dark or darker than No. 2 on the Ringelmann Chart, or of such opacity as to obscure an observer's view to an equivalent or greater degree, nor shall said emission, as perceived by an opacity sensing device in good working order, where such device is required by District regulations, be equal to a greater than 40% opacity, from the following sources:

- 303.1 Internal combustion engines of less than 25 liters (1500 in³) displacement, or any engine used solely as a standby source of motive power;
- 303.2 Laboratory equipment used exclusively for chemical or physical analyses or experimentation;
- 303.3 Portable brazing, soldering or welding equipment;
- 303.4 Deleted July 11, 1990. (Amended January 5, 1983, July 11, 1990)

6-1-304 Tube Cleaning: During tube cleaning, and except for three minutes in any one hour, a person shall not emit from any heat transfer operation using fuel at a rate of not less than 148 GJ (140 million BTU) per hour, a visible emission as dark or darker than No. 2 on the Ringelmann Chart, or of such opacity as to obscure an observer's view to an equivalent or greater degree, or equal to or greater than 40% opacity as perceived by an opacity sensing device in good working order. The aggregate duration of such emissions in any 24 hour period shall not exceed 6.0 minutes per 1055 GJ (one billion BTU) gross heating value of fuel burned during such 24 hour period.

6-1-305 Visible Particles: A person shall not emit particles from any operation in sufficient number to cause annoyance to any other person, which particles are large enough to be visible as individual particles at the emission point or of such size and nature as to be visible individually as incandescent particles. This Section 6-1-305 shall only apply if such particles fall on real property other than that of the person responsible for the emission.

6-1-306 Diesel Piledriving Hammers: Piledriving hammers powered by diesel fuel shall comply with one of the following standards:

- 306.1 A person shall not emit from any diesel piledriving hammer for a period or periods aggregating more than four minutes during the driving of a single pile, a visible emission which is as dark or darker than No. 1 on the Ringelmann Chart, or of such opacity as to obscure an observer's view to an equivalent or greater degree.
- 306.2 A person shall not emit from any diesel piledriving hammer for a period or periods aggregating more than four minutes during the driving of a single pile, a visible emission which is as dark or darker than No. 2 on the Ringelmann Chart or of such opacity as to obscure an observer's view to an equivalent or greater degree provided that the operator utilizes kerosene, smoke suppressing fuel additives and synthetic lubricating oil, and the requirements of Section 6-1-503 are satisfied. (Adopted July 11, 1990)

6-1-310 Particulate Weight Limitation: A person shall not emit from any source particulate matter in excess of 343 mg per dscm (0.15 gr. per dscf) of exhaust gas volume.

- 310.1 Incineration or Salvage Operations. For the purposes of 6-1-310, the actual measured concentration of particulate matter in the exhaust gas from any incineration operation or salvage operation shall be corrected to the concentration which the same quantity of particulate matter would constitute in the exhaust gas minus water vapor corrected to standard conditions, containing 12% CO₂ by volume, and as if no auxiliary fuel had been used.
- 310.2 Gas-fired Pathological Waste Incinerators. The particulate emissions from gas-fired pathological waste incinerators, where emissions are not mingled with emissions from incineration of general wastes, shall be corrected as specified in Section 6-1-310.1 except that correction for auxiliary fuel shall not be required.
- 310.3 Heat Transfer Operation. For the purposes of 6-1-310, the actual measured concentration of particulate matter in the exhaust from any heat transfer operation shall be corrected to the concentration which the same quantity of particulate matter would constitute in the exhaust gas minus water vapor, corrected to standard conditions, containing 6% oxygen by volume.

6-1-311 General Operations: In addition to the limitation of Section 6-1-310, a person shall not discharge into the atmosphere from any general operation particulate matter from any emission point, at a rate in excess of that specified in Table 1 for the process weight rate indicated. This section shall not apply to fuel-fired indirect heat exchangers.

TABLE 1
ALLOWABLE RATE OF EMISSIONS BASED ON PROCESS WEIGHT RATE

Process wt rate = P		Emission = E	
kg/hour	lbs/hour	kg/hour	lbs/hour
250	550	0.8	1.8
300	660	0.9	2.0
400	880	1.1	2.4
500	1100	1.3	2.9
1000	2205	2.1	4.6
2000	4410	3.3	7.3
3000	6615	4.3	9.5
4000	8820	5.2	11.0
5000	11020	6.0	13.0
10000	22045	9.6	21.0
20000	44090	15.2	33.0
over 26000	57320	18.1	40.0

(interpolation formula deleted May 21, 1980. See page 6-1-5 for formulae.)

Interpolation in kg/hr

$$E \text{ in kg/hr} = 0.02 P^{0.67} \text{ in kg/hr}$$

The interpolation of the data in this Table shall be accomplished by the use of the equation $E = 0.022P^{0.67}$, where E = rate of emission in kg/hour, not to exceed 18.1 kg/hour and P = process weight rate in kg/hour.

Interpolation in lbs/hr

$$E \text{ in lbs/hr} = 4.10 P^{0.67} \text{ in lbs/hr}$$

- 6-1-320 Sulfuric Acid Manufacturing Plants:** A person shall not emit from any operation manufacturing sulfuric acid using as a principal raw material any sulfur-containing material, any emission having a concentration of SO₃ or H₂SO₄, or both, expressed as 100% H₂SO₄, exceeding 92 mg per dscm (0.04 gr. per dscf) of exhaust gas volume.
- 6-1-330 Sulfur Recovery Units:** A person shall not emit from any operation manufacturing sulfur, using as a principal raw material any sulfur-containing material, any emission having a concentration of SO₃ or H₂SO₄, or both, expressed as 100% H₂SO₄, exceeding 183 mg dscm (0.08 gr. dscf) of exhaust gas volume.
- 6-1-400 ADMINISTRATIVE REQUIREMENTS**
- 6-1-401 Appearance of Emissions:** Every person responsible for an emission (except from gas fired heat transfer operations regulated by Sections 6-1-301, 6-1-303 and 6-1-304) shall have and maintain means whereby the operator of the plant shall be able to know the appearance of the emission at all times.
- 6-1-500 MONITORING AND RECORDS**
- 6-1-501 Sampling Facilities and Instruments Required:** Persons subject to this regulation shall provide sampling facilities and install instruments as required pursuant to the provisions of Sections 1-501, 1-520 and 1-521 of Regulation 1.
- 6-1-502 Data, Records and Reporting:** Persons monitoring emissions in accordance with the requirements of Sections 1-520 and 1-521 of Regulation 1 shall keep records, report emission excesses and provide summaries of data collected as required by Regulation 1.
- 6-1-503 Records:** A person responsible for the operation of a diesel pile-driving hammer who chooses to comply with subsection 6-1-306.2 shall maintain and have available for inspection records which establish the use of kerosene, smoke suppressing fuel additives and synthetic lubricating oil. (Adopted July 11, 1990)

6-1-600 **MANUAL OF PROCEDURES**

6-1-601 **Particulate Matter, Sampling, Sampling Facilities, Opacity Instruments and Appraisal of Visible Emissions:** The MOP contains the testing temperature for the determination of the presence of particulate matter, procedures relating to the siting of sampling facilities, source test procedures, opacity instrument specifications, calibration and maintenance requirements, and the procedure for appraising visible emissions.

**REGULATION 3
FEES**

**SCHEDULE R
EQUIPMENT REGISTRATION FEES**

1. Persons operating commercial cooking equipment that are required to register equipment as required by District rules are subject to the following fees:
 - a. ConveyORIZED Charbroiler REGISTRATION FEE: \$475 360
 - b. ConveyORIZED Charbroiler ANNUAL RENEWAL FEE: \$135 100
 - c. Under-fired Charbroiler REGISTRATION FEE: \$475 360
 - d. Under-fired Charbroiler ANNUAL RENEWAL FEE: \$135 100

(Adopted June 6, 2007)

Bay Area Air Quality Management District
939 Ellis Street
San Francisco, CA 94109

Staff Report

**Regulation 6, Rule 2:
Commercial Cooking Equipment**

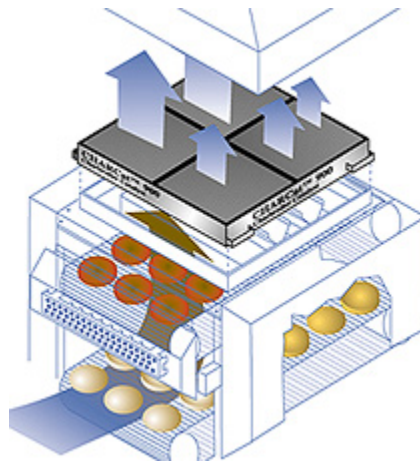

November 2007

Prepared by:

**Virginia Lau
Senior Air Quality Specialist
Planning and Research Division**

Table of Contents

I.	EXECUTIVE SUMMARY	1
II.	BACKGROUND	3
	A. Introduction	3
	B. Source Description.....	4
	C. Emissions Inventory.....	5
	D. Regulatory Framework.....	8
III.	AVAILABLE CONTROL TECHNOLOGY	9
IV.	REGULATORY PROPOSAL	13
	A. Proposed Standard for Chain-Driven Charbroilers	13
	B. Proposed Standard for New Under-Fired Charbroiler Installations.....	14
	C. Proposed Standard for Existing Under-Fired Charbroilers	14
	D. Administrative Requirements	15
V.	EMISSION REDUCTIONS	17
VI.	ECONOMIC IMPACTS	18
	A. Cost Analysis for Charbroilers	18
	C. Incremental Cost Effectiveness	26
	D. District Staff Impacts	27
	E. Socioeconomic Impacts	28
VII.	ENVIRONMENTAL IMPACTS.....	29
VIII.	REGULATORY IMPACTS	29
IX.	RULE DEVELOPMENT PROCESS.....	29
X.	FUTURE RESEARCH.....	32
XI.	CONCLUSION	33
XII.	REFERENCES.....	34

APPENDICES

Appendix A	Emission Calculations
Appendix B	South Coast Air Quality Management District’s Protocol, “Determination of Particulate and Volatile Organic Compound Emissions from Restaurant Operations”, November 14, 1997
Appendix C	Responses to Comments
Appendix D	Socioeconomic Analysis
Appendix E	CEQA Analysis and Negative Declaration

I. EXECUTIVE SUMMARY

Every day in the Bay Area, commercial charbroiling operations collectively emit an estimated 6.9 tons of particulate matter (PM) and 1.1 tons of volatile organic compounds (VOC). The Bay Area and neighboring regions are not yet in attainment with the State one-hour and eight-hour ozone standards and particulate matter standards and so further reductions of VOC and PM are needed.

Currently, no Bay Area Air Quality Management District (District) rule directly regulates emissions from restaurants. The District proposes adoption of Regulation 6, Rule 2 in accordance with its Senate Bill (SB) 656 Particulate Matter Implementation Schedule, and in connection with Further Study Measure (FS) 3 in the District's 2005 Ozone Strategy, which proposes evaluation of a rule to control emissions from commercial charbroilers.

The District focused its efforts on reducing emissions from two types of charbroilers: chain-driven charbroilers and under-fired charbroilers. Charbroilers are a central appliance for most restaurant kitchens and produce over 80% of commercial cooking emissions.

The District investigated a variety of control options for addressing emissions from charbroilers. To determine a list of available control technologies, the District reviewed reports and studies conducted either by universities, other air districts, and city health departments. Regulation 6, Rule 2 will require any restaurant with a chain-driven charbroiler to install a catalytic oxidizer to limit emissions of both PM and VOC if the restaurant purchases at least 500 pounds of beef per week and cooks at least 400 lbs of beef per week on the charbroiler. Owners of restaurants that have one or more under-fired charbroilers with a total grill surface area of at least 10 square feet that purchase at least 1,000 pounds of beef per week and that cook at least 800 pounds of beef per week on the charbroiler will be required to install a control device certified to reduce PM emissions. The proposed rule will become effective one year after the rule is adopted for chain-driven charbroilers and two or five years for under-fired charbroilers, depending on whether the charbroilers were new or existing, respectively. The District anticipates these proposed standards will result in an 85% reduction in PM emitted by all affected charbroilers and an 80% reduction in VOC emitted by chain-driven charbroilers.

A socioeconomic analysis of the proposed regulation concludes that the new regulation would not have significant adverse economic effects. An initial study of the proposed regulation concludes that the rule would not cause significant adverse environmental impacts, and a CEQA negative declaration is proposed for adoption.

Because this regulation addresses a new source category, the District undertook a comprehensive public outreach program to involve in the development of the proposed rule all stakeholders, including individual restaurant owners, hood manufacturers, restaurant trade organizations and industry representatives, county health departments, and vendors and installers of commercial kitchen appliances. The District held four public workshops on November 14 and 15, 2006, and based on public input, revised the draft proposal for presentation at a fifth workshop held on March 6, 2007. The draft proposal was presented before the Board of Directors at the May 16, 2007 public hearing. The Board directed District staff to conduct additional research. District staff surveyed over 400 Bay Area restaurants to determine charbroiler grill sizes and types and amounts of meats grilled. Based on analysis of the survey results, staff revised the proposed regulation. In addition, District staff refined its cost analysis based on further discussions with restaurant owners, control device manufacturers, and building maintenance personnel. The revised draft proposal was presented at a sixth public workshop on October 23, 2007, and comments received at that meeting and during the comment period have been incorporated into the final proposal and into this staff report, as appropriate.

In addition to proposed Regulation 6, Rule 2, the District proposes amendments to *Regulation 3, Schedule R: Equipment Registration Fees* and *Regulation 6: Particulate Matter and Visible Emissions*. The amendments to Schedule R propose a reduction in fees for restaurants and the amendments to Regulation 6 renumber and rename the rule. The amendments to *Regulation 6: Particulate Matter and Visible Emissions* do not have any substantive effect.

II. BACKGROUND

A. Introduction

Restaurants vent substantial amounts of particulate matter (PM) and volatile organic compounds (VOC) into the atmosphere. Every day in the Bay Area, commercial charbroiling operations collectively emit an estimated 6.9 tons of PM and 1.1 tons of VOC.

Several California air districts have adopted rules limiting emissions from commercial cooking operations. The South Coast Air Quality Management District (SCAQMD) funded a detailed study that determined chain-driven charbroilers, under-fired charbroilers, and griddles generate most of the VOC and PM emissions from commercial cooking operations. At present, SCAQMD, the San Joaquin Valley Unified Air Pollution Control District, and the Ventura County Air Pollution Control District have each adopted a rule that limits emissions from restaurant charbroilers. Each of these rules requires chain-driven charbroilers to operate with a control device to limit the emissions of VOC and PM.

Currently, no District rule directly regulates emissions from restaurants. The District proposes adoption of Regulation 6, Rule 2 to fulfill a commitment in its Senate Bill (SB) 656 Particulate Matter Implementation Schedule, and in connection with Further Study Measure (FS) 3 in the District's 2005 Ozone Strategy, which proposes evaluation of a rule to control emissions from commercial charbroilers.

The initial proposal was presented before the Board of Directors at the May 16, 2007 public hearing. At the conclusion of the meeting, the Board directed District staff to conduct additional research. The most significant changes that have been incorporated into the proposed rule include:

- A provision that defines which restaurants are subject to the proposed rule based on the amount of beef purchased;
- An exemption for restaurants that do not cook on the charbroiler most (80%) of the beef purchased; and
- The removal of the requirement to install listed ventilation hoods.

The Board of Directors directed District staff to conduct additional research on certain questions that were raised during the public hearing. District staff conducted a survey of Bay Area restaurants to determine charbroiler grill sizes and types and amounts of meats cooked. Staff also further analyzed the costs to operate and maintain control technologies. This staff report incorporates the findings from these studies as well as revisions to the proposed rule.

B. Source Description

Commercial cooking equipment generates grease, smoke, heat, water vapor, and combustion products. A typical kitchen ventilation system includes an exhaust hood, ductwork, and fan system that extracts heat and pollutants and captures grease using filters, extraction baffles, or water mist systems. The cooking plume rises from the cooking appliance through the filters aided by the suction of the exhaust fan, located in most cases on the roof of the restaurant. Large particulates are generally captured in the filters while additional particulates condense in the duct work or in the exhaust fan.

Broilers are the central appliance for most restaurant kitchens and are used to cook steak, hamburgers, fish, chicken, and seafood, as well as to brown food and reheat plated food. All broilers are comprised of a grated grill and a heat source, where food resting on the grated grill cooks as the food receives heat either directly from the heat source, or indirectly by way of a radiant surface.

Proposed Regulation 6, Rule 2 would regulate two types of charbroilers: chain-driven and under-fired. Figure 1 presents examples of a chain-driven charbroiler and an under-fired charbroiler. A chain-driven (conveyorized) charbroiler is a semi-enclosed broiler designed to move food mechanically on a grated grill through the device as the food cooks. Food cooks quickly, because chain-driven charbroilers have burners located both above and below the grill. Chain-driven charbroilers are most common in fast food restaurants.

Figure 1. Examples of Chain-Driven Broiler (left) and Under-Fired Broiler (right)



Sources: Nieco and Magikitch'n

In an under-fired charbroiler, the heat source is positioned at or below the level of the grated grill. Designs of under-fired charbroilers vary widely. Some under-fired broilers use charcoal or wood for fuel, but usually, the broilers are fueled by gas or electricity. In gas under-fired charbroilers, a radiant surface, such as a

bed of ceramic briquettes or a metal shield, placed above the burners diffuses heat from the burners. (See Figure 2.) The heating elements of electric charbroilers are often interwoven with, or sheathed inside, the grill. Under-fired charbroilers are common in fine dining and casual restaurants.

Figure 2. Diagram of Under-Fired Charbroiler

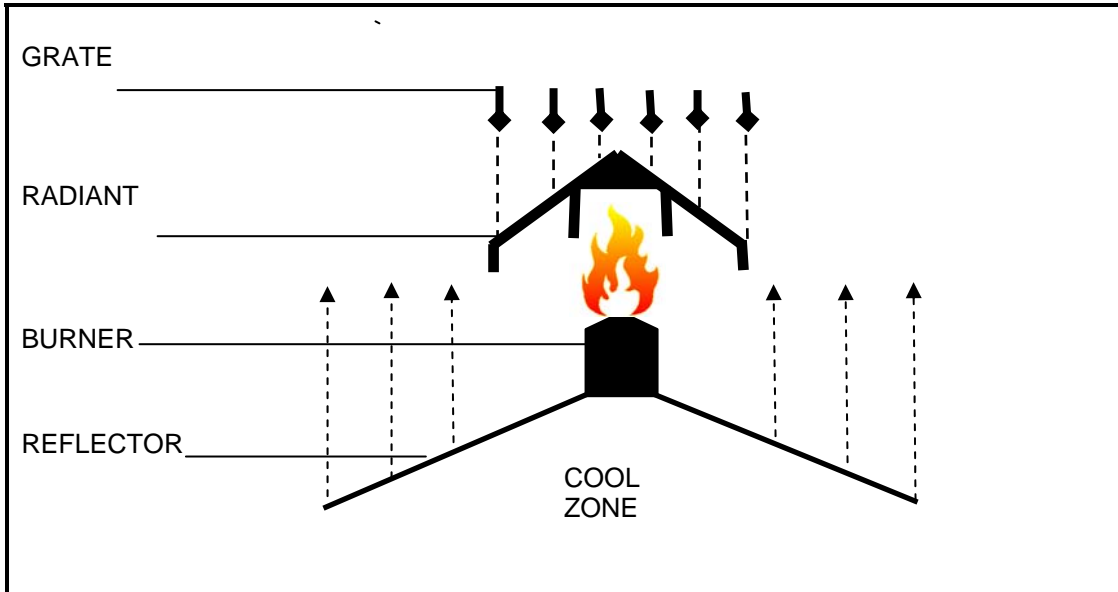

Source: Vulcan-Hart Company

C. Emissions Inventory

Charbroilers produce air pollutants through combustion. The air pollutants are primarily generated from incomplete combustion of grease and meat additives, such as tenderizers and marinade. The air contaminants are released when grease and meat additives fall onto the heat source, radiant surface, or hot plate, or when grease flares in the drip tray or bubbles at the surface.

The smoke and vapors generated from the process contain VOC and PM that consist of aldehydes, organic acids, alcohol, nitrogen and sulfur compounds, and polycyclic aromatic hydrocarbons (PAHs). VOC reacts with other compounds in the atmosphere to form ground-level ozone, commonly called smog. PM consists of airborne particles. PM can be emitted directly and also can be formed in the atmosphere through chemical reactions between other pollutants, including VOC. Cooking emissions include fine particles that are equal to or less than 10 microns in diameter, commonly referred to as PM₁₀. PM₁₀ generated by cooking appliances passes through the ventilation system and is exhausted into the atmosphere. Particulate matter greater than 10 microns in diameter is typically captured in the grease filter in the ventilation hood, and is not exhausted to the atmosphere.

Both VOC and PM₁₀ present public health risks. Ozone produced from chemical reactions involving VOC may damage lung tissues and the respiratory tract. Once inhaled, PM₁₀ may become lodged in the respiratory tract and lead to wheezing, nose and throat irritation, bronchitis, aggravated asthma, and lung damage.

The SCAQMD and the California Air Resources Board (CARB) sponsored several studies in order to determine the percentage of restaurants that use charbroilers, the amount and type of meat cooked on charbroilers, and the amount of PM₁₀ and VOC produced from meat cooked on charbroilers. The District relied on these research studies, and on information provided by the health department of each of the nine Bay Area counties, to estimate the amount of PM₁₀ and VOC emitted from restaurant charbroilers in the Bay Area. A more detailed description of the methodology is presented in Appendix A.

District staff estimated the number of restaurants in operation in the Bay Area with assistance from the health department of each county in the District. Each county health department provided the District with the number of restaurants permitted within the county. District staff refined the number of restaurants by eliminating the establishments that are not open to the public (e.g., private clubs, dormitories, and company cafeterias) because charbroiler usage would likely be much less than a commercial restaurant. Restaurants that have gone out of business, as well as those that are less likely to cook, such as, ice cream parlors and delicatessens were also eliminated. The District estimates that there are approximately 14,838 restaurants in the Bay Area.

To estimate the number of charbroilers used in Bay Area restaurants, the District consulted the 1997 SCAQMD report, "Staff Recommendations Regarding Controlling Emissions from Restaurant Operations." The SCAQMD report surveyed the type of equipment that was used in restaurant cooking operations in Southern California. The report found that approximately 33% of restaurants operate under-fired charbroilers and 3.7% operate chain-driven charbroilers. The District verified these percentages by conducting an independent survey of Bay Area restaurants. District staff interviewed a random sample of approximately 400 restaurants that included fast food chains and franchises and found that the SCAQMD percentages are representative of the Bay Area. Based on these percentages, the District estimates that approximately 4,897 Bay Area restaurants operate under-fired charbroilers and 554 operate chain-driven charbroilers.

The District used several studies to estimate the amount of meat cooked on restaurant charbroilers and the associated emissions. The District relied on data developed for CARB by the Public Research Institute pertaining to the average amount of meat cooked on each type of appliance. Table 1 presents the estimated average pounds of meat cooked per year on an individual charbroiler in the Bay Area.

Emission factors developed by the University of California Riverside (UCR) and the University of Minnesota were used to quantify average emissions from each type of meat cooked on under-fired charbroilers including hamburger, steaks, chicken with or without skin, pork, and seafood. For chain-driven charbroilers, emission factors for poultry, pork, and seafood were estimated from the factors developed for under-fired charbroilers. The estimated emissions of PM₁₀ and VOC by chain-driven and under-fired charbroilers are presented in Table 2.

Table 1. Estimated Average Yearly Pounds of Meat Cooked per Charbroiler in the Bay Area

Type of Food	ConveyORIZED Broiler (lbs/year)	Under-Fired Broiler (lbs/year)
Hamburger	41,486	14,049
Beef Steaks	12,281	9,363
Poultry with Skin	7,651	7,485
Poultry without Skin	13,842	9,311
Pork	2,997	7,699
Seafood	6,179	7,416
TOTAL	84,436	55,323

Source: PRI

Table 2. Emissions from Charbroilers in the Bay Area

Type of Food	Chain-driven Broiler		Under-Fired Broiler	
	PM10 (tons/day)	VOC (tons/day)	PM10 (tons/day)	VOC (tons/day)
Hamburger	0.23	0.072	0.90	0.37
Beef Steaks	0.069	0.021	0.60	0.25
Poultry with Skin	0.0091	0.0061	0.10	0.092
Poultry without Skin	0.016	0.011	0.12	0.11
Pork	0.0036	0.0024	0.10	0.094
Seafood	0.012	0.010	0.16	0.019
Total Emissions (tons/day)	0.34	0.11	2.0	0.94
Total Emissions (tons/year)	126	41	724	342

As noted in Table 2, a significant portion of the PM₁₀ and VOC emissions from charbroilers are produced from beef products such as hamburgers and beef steaks. Beef products account for approximately 62% of PM₁₀ and VOC emissions from chain-driven charbroilers and approximately 75% of PM₁₀ and

66% of VOC emissions from under-fired charbroilers. The Bay Area restaurant survey also verified that beef is the meat most commonly cooked on a charbroiler. The proposed rule would regulate those restaurants that purchase and grill a significant amount of beef because these restaurants are responsible for the largest share of emissions. Emission reductions were estimated assuming that restaurants subject to this proposed rule cook a variety of meats, but predominately beef.

In addition to VOC and PM emissions, cooking operations also produce carbon dioxide (CO₂), a gas contributing to climate change. In 2005, the District adopted a Climate Protection Program aimed at reducing greenhouse gas emissions. A University of Minnesota study found that gas charbroilers generated most of the CO₂ emitted by cooking operations. Charbroilers generate CO₂ through the combustion of natural gas and when grease drippings combust on hot radiant surfaces. The District estimates that the average CO₂ emissions for cooking activities per restaurant are approximately 25,000 pounds of CO₂ annually based on operation of the cooking appliances and energy usage for the associated ventilation system¹.

D. Regulatory Framework

The District is proposing Regulation 6, Rule 2, in accordance with the District's SB 656 Particulate Matter Implementation Schedule and in connection with FS 3 in the District's 2005 Ozone Strategy, as a means to reduce restaurant emissions of PM and VOC in the Bay Area. VOCs are ozone precursors, and also contribute to indirect or secondary PM. The Bay Area is not yet in attainment of the State ozone and particulate matter standards, and so, further reductions of VOC and PM are needed.

SB 656 requires that all air districts in California adopt an implementation schedule that prioritizes appropriate measures for reducing PM emissions. The District's Particulate Matter Implementation Schedule, adopted in November 2005 proposed to adopt Regulation 6, Rule 2 as a measure to reduce direct and indirect PM emissions in the Bay Area.

Under FS 3, the District proposed to examine the feasibility of reducing ozone precursor emissions from restaurants. FS 3 is part of the District's 2005 Ozone Strategy, directed towards attainment of the State one-hour ozone standard.

Currently, no District rule directly regulates the emissions of air pollutants from restaurants. Restaurants, cafeterias, and other food establishments are not required to obtain a permit to operate under the District's Regulation 2, Rule 1. Nevertheless, restaurants must comply with the District's regulations of general

¹ Energy usage only accounts for the energy required to operate the cooking appliances and associated ventilation system. It does not include the energy required to power the air conditioning and heating systems, refrigeration units, make-up air, lights, and other types of equipment.

applicability, such as *Regulation 6: Particular Matter and Visible Emissions*, and *Regulation 7: Odorous Substances*². Regulation 6 sets limitations on the emissions of particulate matter. Regulation 7 restricts the discharge of odorous substances.

Bay Area restaurants are issued permits to operate by county health departments and in some cases, city health departments. The health departments require restaurants to adhere to California building codes, fire protection codes, and retail food laws. These codes require restaurants to install an exhaust ventilation hood with a fire suppression system above commercial cooking equipment that generates grease, smoke, steam, and vapor. The health departments also monitor the handling of food and ensure that all of the grease traps and hood filters are routinely cleaned.

At present, the SCAQMD, San Joaquin Valley Unified Air Pollution Control District, and Ventura County Air Pollution Control District have each adopted a rule that limits emissions from restaurant charbroilers. These rules each require that chain-driven charbroilers be operated with a control device to limit emissions of VOC and PM.

In addition, the City of Aspen Environmental Health Department has an ordinance regulating restaurant charbroiler emissions under Municipal Code Section 13.08.100: Restaurant Grills. The ordinance requires all restaurants that operate any charbroiler to install a control device that is certified by the manufacturer to reduce PM₁₀ emissions by 90%.

III. AVAILABLE CONTROL TECHNOLOGY

The District considered a variety of technologies to control emissions from charbroilers. District staff reviewed reports and studies conducted by the UCR, College of Engineering, Center for Environmental Research and Technology (CE-CERT), on available control technologies in support of the SCAQMD Regulation 1138 to control emissions from chain-driven charbroilers. In addition, District staff contacted the City of Aspen Environmental Health Department regarding their ordinance regulating restaurant charbroiler emissions under Municipal Code Section 13.08.100: Restaurant Grills. District staff also consulted hood manufacturers and industry representatives.

Available control technologies that are effective at removing either or both PM and VOC from charbroilers include catalytic oxidizers and thermal incinerators. Each of these is a reliable, proven, and commonly-used control technology. The District also considered wet scrubbers, electrostatic precipitators (ESPs), fiber-bed filters, and high-efficiency particulate arresting (HEPA) filters as effective control devices for removing PM only. Other control technologies such as

² On adoption of proposed Regulation 6, Rule 2, current Regulation 6 will be re-numbered as Regulation 6, Rule 1.

ultraviolet (UV) lamps and high-efficiency filters are available. The effectiveness of UV lamps at removing PM and VOC has not been investigated in an independent research study. High-efficiency filters have a significantly lower PM removal efficiency in comparison to the proven control technologies discussed below.

Catalytic Oxidizers (flameless)

A catalytic oxidizer is a flameless incineration device that is fitted to the top of a chain-driven charbroiler. Cooking exhaust is initially processed in the catalytic oxidizer through the heat exchanger where air is introduced. The air mixture then enters a flameless combustion chamber where it is evenly distributed onto the catalyst bed to ensure complete mixing of PM and VOC with oxygen. The PM and VOC oxidize into carbon dioxide and water vapor once the mixture reaches the combustion temperature. The released combustion energy is absorbed by the catalyst bed and is transferred to the heat recovery system. The control device is activated by the heat of the charbroiler and does not require any additional fuel to operate. The catalyst, which is a metal alloy, covers a substrate, typically either a honeycombed ceramic or a bed of ceramic beads housed in a canister. (See Figure 3.)

Figure 3. Catalytic Oxidizers Canisters

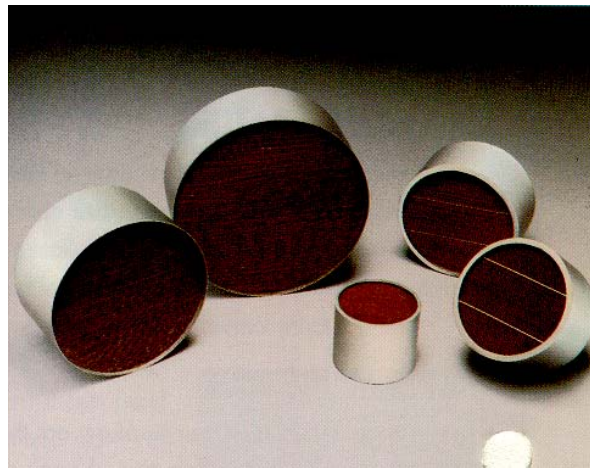

Source: W.R. Grace and Company

The catalyst is cleaned by immersion in water for one hour per month. Testing has shown catalytic oxidizers are capable of an overall PM and VOC removal efficiency of approximately 85% (83% for PM and 86% for VOC). Catalytic oxidizers are highly effective and virtually maintenance-free control devices for chain-driven charbroilers. However, this technology is not used to control emissions from under-fired charbroilers because the temperature at which the catalyst operates would require significant energy usage. Control equipment for under-fired charbroilers is mounted in the exhaust system, not on the broiler.

Thermal Incineration

Thermal incineration oxidizes PM and VOC from an air stream at high temperatures, converting them into carbon dioxide and water. Thermal incinerators are not commonly used in commercial cooking applications. There are two types of thermal incinerators, recuperative and regenerative. Thermal recuperative incinerators consist of a gas preheating section (heat exchanger), a combustion chamber typically equipped with gas burner(s), and a heat recovery section. The heat exchanger is used to preheat the exhaust stream prior to combustion and may be used to recover heat to generate steam.

Regenerative incinerators use direct contact with a high-density medium such as a ceramic-packed bed or catalyst bed for heat recovery and to preheat the exhaust stream. Preheated PM and VOC enters the combustion chamber where they are converted to carbon dioxide and water. Cleaned gases are then diverted to reheat the packed beds. PM and VOC removal efficiency is dependent upon temperature, residence time, and mixing inside the incinerator.

PM and VOC conversion efficiencies typically range from 97% to 99.9% for recuperative incineration and 95% to 99% for regenerative incinerators. Thermal incinerators may be used as a control device for both chain-driven and under-fired charbroilers.

Fiber-Bed Filters

Fiber-bed filters may be used as stand-alone control devices or in conjunction with another control device such as a wet scrubber. Fiber-bed filters use a combination of impaction, interception and Brownian diffusion to remove particulate matter from an air stream. Particulates become trapped in the fibers of the filter and eventually drain into a capture area below the filter as illustrated in Figure 4. The filter bed may be made of fiberglass, polyester, polypropylene, or ceramic, depending on the PM concentration, exhaust flow, and temperature of the air stream.

Figure 4. Operation of Typical Fiber-Bed Filters

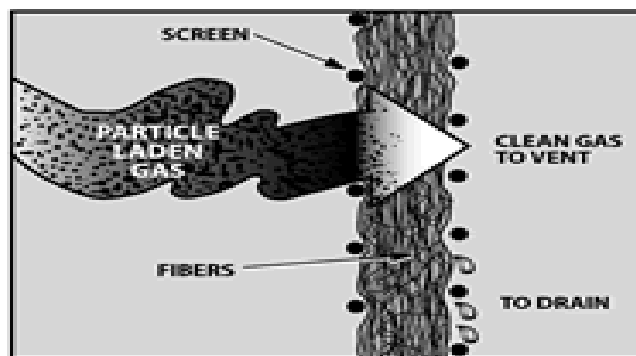

Source: Kimre, Inc.

Periodically the filters must be replaced or washed to remove grease and other materials before returning to service. Fiber-bed filters have an overall PM removal efficiency of 90%. Filter-bed technology has been successfully used on chain-driven charbroilers in Southern California; however, they are not used in restaurants that operate under-fired charbroilers and thus, the costs for installing and maintaining the control device are not included for under-fired charbroilers.

Electrostatic Precipitators

Electrostatic precipitators (ESPs) have a proven track record of removing PM from the gas streams of many industries. An ESP functions by screening out large PM with a pre-filter, and then imparting an electrostatic charge in the remaining exhaust particles with a high voltage direct current. The charged particles then attach to an oppositely charged plate, from which they are later removed. An after filter is occasionally used after the plates to restore a positive back-pressure and ensure good gas distribution.

The PM removal efficiencies of ESPs range from 90% to 99%. The removal efficiencies depend largely on whether the ESPs are frequently and properly cleaned. ESPs are effective control devices for either chain-driven charbroilers or under-fired charbroilers.

Wet Scrubbers

Wet scrubbers use a finely atomized stream of water to remove PM from an air stream. An exhaust stream flows upward through a series of grated impingement plates. Water is introduced from the top of the wet scrubber and flows down to each successive plate, counter to the exhaust flow. The cooking exhaust rises through the grated grills and cools once it contacts the water. The particles adhere to the water droplets which are then collected as liquid waste. The liquid waste collected at the bottom of the scrubbers requires either treatment for reuse or disposal. Liquid particles entrained in the exhaust gas leaving the scrubber are removed using an after filter. PM removal efficiencies of 90% to 99% have been achieved depending on particle size, load, flows, and pressure drop. Wet scrubbers may be used as a control device for either the chain-driven or under-fired charbroiler.

HEPA Filters

HEPA filters are comprised of a series of three (3) filters designed to capture successively finer particles sizes. The first filter is called a pre-filter, which is a fully disposable pleated filter that must be replaced every four (4) weeks. The second filter is a medium filter that is a fully disposable bag filter that is replaced every eight (8) weeks. The final filter is a fully disposable 12 inch HEPA filter that is replaced every six (6) months. The PM removal efficiencies of HEPA filters

varies from 95% to 99%. HEPA filters have been exclusively used at restaurants that operate under-fired charbroilers. Because there are more inexpensive control options available, restaurants with chain-driven charbroilers have not installed this control device.

IV. REGULATORY PROPOSAL

Under proposed Regulation 6, Rule 2: Commercial Cooking Equipment, the District is seeking to achieve further reductions of VOC and PM by requiring controls for under-fired and chain-driven charbroiler emissions. This chapter describes the proposed standards in Regulation 6, Rule 2.

A. Proposed Standard for Chain-Driven Charbroilers

Based on studies conducted by the UCR CE-CERT (1997), chain-driven charbroilers account for 4% of restaurant PM emissions and 13% of VOC emissions. Proposed Regulation 6, Rule 2 requires that, within one year of adoption of the rule, those owners of restaurants that have chain-driven charbroilers and that purchase 500 pounds (lbs.) or more of beef per week would be required to install and operate a District-approved catalytic oxidizer or other certified control. Restaurants that demonstrate, through meat purchase invoices or other documentation, that they cook less than 400 lbs. of beef per week on their charbroilers would be exempt from this proposed rule.

Currently, three California air districts regulate chain-driven charbroiler emissions: SCAQMD, San Joaquin Valley Unified Air Pollution Control District, and Ventura County Air Pollution Control District. Each of these air districts requires chain-driven charbroilers to be equipped and operated with a catalytic oxidizer or equivalent control. As a result, the catalytic oxidizer has an established track record and has been proven capable of reliably reducing chain-driven charbroiler emissions of PM₁₀ by 83% and VOC by 86%. The South Coast AQMD has already approved catalytic oxidizers from a variety of manufacturers to meet the same emissions standard as included in proposed Regulation 6, Rule 2; the devices SCAQMD has already approved at the time of this writing will be approved for use in the Bay Area. A manufacturer of a new catalytic oxidizer will be required to test and certify the equipment according to the protocol SCAQMD established, attached to this staff report as Appendix B.

The proposed rule allows a restaurant operator the flexibility to install an alternative control device, provided the device has been certified by the manufacturer to reduce emissions to no more than 0.74 lbs. of PM₁₀ per 1,000 lbs. of beef cooked. Alternative controls, such as electrostatic precipitators, are capable of achieving a higher PM₁₀ removal efficiency, but at greater cost, than a catalytic oxidizer. In some cases, other controls have already been installed on District restaurants. The manufacturer is required to have an independent laboratory perform the certification test, in accordance with specific procedures prescribed in the rule, to determine the ability of the control to meet the emission

standards the rule requires.

B. Proposed Standard for New Under-Fired Charbroiler Installations

Under-fired charbroilers account for 82% of PM emissions generated by restaurants, according to the 1997 University of California, Riverside study. The focus of the proposed rule for newly-installed under-fired charbroilers is to reduce emissions from high-production restaurants that cook large quantities of beef on under-fired charbroilers and, consequently, are responsible for a large portion of the emissions. Effective January 1, 2010, the proposal calls for any owner or operator of any restaurant that contains one or more new under-fired charbroilers that have a total of at least 10 square feet of grill surface area and that purchases 1,000 lbs. of beef or more per week, to exhaust the restaurant's charbroiler emissions through a certified control device. The control device must be certified by the manufacturer to limit emissions to no more than 1.0 lbs. of PM₁₀ per 1,000 lbs. of beef cooked, as measured by the test method set out in section 603 of the proposed rule. Any restaurant that demonstrates that it grills less than 800 lbs. of beef per week on its charbroiler(s) would be exempt.

The rule recognizes that effective control equipment that meets these emission standards requires planning to install. Newly constructed restaurants can integrate the installation of the controls into their ventilation system to effectively reduce emissions. Owners of an existing restaurant who choose to install new under-fired charbroiler(s) in the restaurant and thereby become subject to the rule will have to install an approved control device. Alternatively, the restaurant owner may elect to install cooking equipment other than an under-fired charbroiler, such as a clamshell griddle or over-fired charbroiler, that emits much less PM than an under-fired charbroiler, and consequently, is not subject to the regulation. Cooking appliances such as clamshell griddles and over-fired charbroilers have the added benefit of using less energy than under-fired charbroilers.

C. Proposed Standard for Existing Under-Fired Charbroilers

Approximately 82% of Bay Area PM emissions from commercial cooking are attributable to the approximately 5,000 under-fired charbroilers in use in the Bay Area. PM emissions from already-existing under-fired charbroilers can be reduced by 14% (up to 0.28 tpd) by regulating the highest emitting restaurants (approximately the top 4%) that operate under-fired charbroilers.

Five years after rule adoption, January 1, 2013, the proposed rule will require all restaurants that have one or more under-fired charbroilers with an aggregate grill surface area of 10 square feet or more and that purchase 1,000 lbs of beef or more per week to install control technology certified to emit no more than 1.0 lbs. of PM₁₀ per 1,000 lbs. of beef cooked, as measured by the test method set out in section 603 of the proposed rule. This will reduce PM₁₀ emissions from these restaurants by 90%. Any restaurant that demonstrates that it grills less than 800 lbs. of beef per week would be exempt.

Current control technologies are available that can be retrofitted into existing restaurants. However, some restaurants may require remodeling, additional plumbing, or additional structural support in order to install and operate currently available control devices. As a result, an extended implementation date for existing under-fired charbroilers is proposed to allow adequate time for restaurant owners to plan, obtain the necessary building permits, purchase, and install the control.

D. Administrative Requirements

Chain-Driven Charbroilers

All operators of chain-driven charbroilers that are subject to this proposed rule will be required to register the charbroiler and control device with the District. The District will implement a web-based registration system to simplify the registration process. Controls that have been certified for use in the South Coast will be approved and listed on the District web site as well as new, District-certified catalytic oxidizers. Restaurant owners will be assessed an initial registration fee and recurring annual fee to recover the District's costs of administering and enforcing the proposed rule. The proposed initial registration fee is \$360 and the proposed annual fee is \$100. The fees are to be adopted as part of the proposed amendments to Regulation 3: Fees.

The proposed rule also has a recordkeeping provision that requires owners and operators to record the date of installation of, and any maintenance and repairs performed on, the control device. The repair logs will contain the date, time, and description of the work that was performed. The owner or operator must keep the records for at least five years. The purpose of this recordkeeping requirement is to ensure that the control is operated in accordance with the manufacturer's specifications.

Under-Fired Charbroilers

An operator of a restaurant with one or more under-fired charbroiler(s) that is subject to this proposed rule will be required to register the under-fired charbroiler(s) and the control device. Restaurant owners will be assessed an initial registration fee, followed by a recurring annual fee to recover the District's costs of administering and enforcing the proposed rule. The proposed registration fee is \$360 and the proposed annual fee is \$100, consistent with the fees for chain-driven charbroilers. The fees are to be adopted as part of the proposed amendments to Regulation 3: Fees.

The proposed rule requires that owners and/or operators of restaurants subject to the rule must keep records for not less than five years. The records must include date of installation of any control device operated to comply with the rule and records of any maintenance or repairs performed on the control device. The

maintenance and repair records must contain the date, time, and description of the work that was performed. The purpose of this recordkeeping requirement is to ensure that the control is operated in accordance with the manufacturer's specifications.

Certification of Control Equipment

The manufacturer of an emission control device must contract an independent laboratory to perform a test, in accordance with specific procedures prescribed in the rule, to certify the ability of the control to meet the relevant emission standards in the rule. The manufacturer is required to submit to the District an application containing a complete source test report along with information describing the control and to certify that the device meets the emissions requirements.

The proposed rule requires the certification tests for all devices controlling emissions from under-fired charbroilers and for controls other than catalytic oxidizers for chain-driven charbroilers to be performed according to the protocol set out in proposed section 6-2-603 and -602, respectively. The test protocols are intended to measure PM₁₀, excluding condensable vapors.

The proposed sections 6-2-602 and -603 protocols employ EPA Method 5, which measures total particulate, and not PM₁₀ as such; however, the protocols are designed so that the vast majority of PM in the effluent stream that reaches the EPA Method 5 sampling train will be PM₁₀.

According to the CE-CERT study, "Further Development of Emission Test Methods and Development of Emission Factors for Various Commercial Cooking Operations" (1997), particulate matter greater than 10 microns in size is generally not emitted into the atmosphere, because the standard baffle filters installed in restaurant kitchen ventilation systems capture particles greater than 10 microns in size, termed coarse particulate. The CE-CERT study showed that the particulate matter that passed through the baffle filter was all PM₁₀. Likewise, the effluent stream that will reach the EPA Method 5 sampling train under the proposed sections 6-2-602 and -603 protocols will consist of particulates less than 10 microns in diameter because the test protocol requires that the test effluent stream pass through a baffle filter.

In addition, the testing protocols set out in sections 602 and 603 of the proposed rule are intended to exclude condensable vapors from measurement. Emissions from charbroiling include particulate matter and compounds that condense into particulate matter as they cool. These latter compounds are termed condensable vapors, and are included in the definition of total PM₁₀. As condensable vapors leave the very hot surface of a charbroiler, they cool and condense into PM. Some condensable vapors condense prior to being exhausted into the atmosphere; much does not. A control device that does not oxidize emissions,

such as an electrostatic precipitator or a HEPA filter, will remove only the vapors that condense prior to reaching the control device. The test method set out in sections 602 and 603 of the proposed rule, which provide the standards for certification testing of control devices other than catalytic oxidizers for use with charbroilers, measures only particles captured by, and condensable vapors that condense onto, the particulate filters used in the front half of the EPA Method 5 test. As a result, the test methods set out in sections 602 and 603 of the proposed rule are designed to measure the particulate matter, including condensable particulate, that the control device could be expected to collect.

V. EMISSION REDUCTIONS

Charbroilers produce PM and VOC through incomplete combustion of tenderizers, marinade, and fats in the meat cooked. The District estimates that chain-driven charbroilers in the Bay Area emit a total of 0.34 tons per day (tpd) of PM and 0.11 tpd of VOC. Under-fired charbroilers, which produce significantly more emissions and outnumber chain-driven charbroilers by roughly a ten to one ratio, collectively emit approximately 2.0 tpd of PM and 0.94 tpd of VOC in the Bay Area. Cooking beef produces approximately 62% of the particulate emissions from chain-driven charbroilers and 75% of the particulate emissions from under-fired charbroilers because it represents the bulk of the meat cooked on these appliances and has about three times the emission rate of chicken, pork, or seafood. A more detailed discussion of the emissions estimates is presented in Appendix A.

Chain-Driven Charbroilers

The proposed standards for chain-driven charbroilers will become effective on January 1, 2009. Based on Bay Area restaurant survey, it is estimated that approximately 80% of all chain-driven charbroilers will be subject to this proposed rule; the remaining 20% of restaurants with chain-driven charbroilers either do not purchase over 500 lbs of beef per week or cook less than 400 lbs of beef per week on the charbroiler. The restaurants subject to this proposed rule emit 93% of the PM and VOC emissions from chain-driven charbroilers. The installation of control equipment is anticipated to reduce emissions of PM from these chain-driven charbroilers by 83% (0.27 tpd) and of VOC by 86% (0.091 tpd). Laboratory testing (UCR, 2002) conducted on catalytic oxidizers has verified that the control devices are capable of achieving these emission reductions.

New Under-Fired Charbroilers

The proposed standards for new installations of large under-fired charbroilers will become effective on January 1, 2010. Based on data provided by the county health departments, about 25 restaurants per year (about 0.5% of all permitted restaurants with under-fired charbroilers) will become subject to the requirements of this rule due to remodeling or new construction. Each year, these new

installations will add an additional 0.010 tons of PM production per day that will be subject to the requirements of the rule. The proposed rule would reduce PM emissions from these new installations by 90% (0.009 tpd).

Existing Under-Fired Charbroilers

The District estimates that there are currently 489 restaurants in the District operating one or more under-fired charbroilers with a total grill surface area of at least 10 square feet. The District estimates that approximately 40% of these restaurants (about 200 restaurants) purchase at least 1,000 lbs of beef per week, and grill at least 800 lbs of beef per week. These restaurants emit 16% of the total PM emissions from under-fired charbroilers, or 0.32 tpd. Effective January 1, 2013, the rule is anticipated to reduce total PM emissions from under-fired charbroilers by 14% (0.28 tpd) (90% from affected under-fired charbroilers). The remaining emissions, approximately 1.7 tpd of PM, are produced from the 4,700 restaurants that currently operate under-fired charbroilers, but are not subject to this proposed rule.

Table 3 presents emissions and emission reductions for charbroilers subject to the proposed rule.

Table 3. Emission Reductions from Charbroilers Subject to Proposed Rule

Type of Charbroiler	Uncontrolled PM ₁₀ Emissions (tpd)	PM ₁₀ Emission Reduction (tpd)	Uncontrolled VOC Emissions (tpd)	VOC Emission Reduction (tpd)
Chain-Driven Charbroilers	0.32	0.27	0.10	0.091
Existing Under-Fired Charbroilers	0.32	0.28	0.15	---
TOTAL	0.64	0.55	0.25	0.091
New Under-Fired Charbroilers*	0.010	0.009	0.005	---

* Note: New under-fired charbroilers estimated to increase at a rate of 10% per year.

VI. ECONOMIC IMPACTS

This section discusses the estimated costs associated with the proposed rule.

A. Cost Analysis for Charbroilers

The District investigated the technical feasibility, potential emission reductions, and costs of installing and operating the control strategies identified in Section III. The total annual costs for a control technology are calculated based on a ten year period and are comprised of the annualized capital costs and the annual

recurring operation and maintenance (O&M) costs.

The District estimated capital costs using the capital recovery method, which accounts for depreciation and interest (i.e., inflation) costs over the useful life of the control. The District annualized the capital costs using the following equation:

$$\text{Total Annualized Cost} = (\text{Capital Recovery Factor}) \times (\text{Capital Expenditure}) + \text{Annual O \& M Costs}$$

Where:

Capital Expenditure is the equipment and installation costs

Capital Recovery Factor is 14.2% (7% per year over 10 years)

Annual O&M Costs are expenditures for utilities and equipment maintenance

The annual recurring O&M cost includes expenditures for cleaning the equipment and the duct work.

District staff also estimated a control technology's cost effectiveness by summing the total annual costs for the control technology installed at restaurants and dividing that sum by the total annual PM and VOC emissions reductions to be achieved.

Chain-driven Charbroilers

Costs associated with control devices for chain-driven charbroilers were derived from the SCAQMD Staff Report for Proposed Rule 1138 (1997) and San Joaquin Valley Unified Air Pollution Control District Draft Staff Report for Commercial Charbroiling (2001). The District verified and adjusted costs to 2007 dollars. Table 4 presents a summary of the total annual cost for installing and maintaining the equipment and Table 5 presents the cost-effectiveness. Because catalytic oxidizers have been designed to work with chain-driven charbroilers and are certified for use in other districts, and because of their low costs relative to other controls, is the District expects that restaurants with chain-driven charbroilers will install catalytic oxidizers.

Catalytic Oxidizers

Capital Costs: Manufacturers sell a catalytic oxidizer at a cost ranging from \$1,500 to \$4,700. For this analysis, the capital cost was assumed to be \$9,000 for a new chain-driven charbroiler equipped with a catalytic oxidizer that includes costs for installing the control, initial catalyst, and replacement catalyst after 5 years (\$4,000). The cost would essentially be the same if an existing broiler was retrofitted with a catalytic oxidizer. Installation of the equipment was assumed to be \$1,000, although typical installation costs ranges from \$500 to \$1,000.

Operating Costs: Annual O&M costs of cleaning the catalyst are expected to be

\$750, which includes monthly cleaning of the catalyst and the cost of cleaning the exhaust stack once a year. Cost savings associated with less frequent cleaning of the grease traps were not included in this cost estimate. The anticipated lifetime of the catalytic oxidizer is seven to eleven years with proper maintenance.

The total annualized cost of installing a catalytic oxidizer, including O&M, is \$2,028 (see Table 5). Based on the estimates of 0.34 tpd of PM emissions and 0.11 tpd of VOC emissions (Table 3) from chain-driven charbroilers, it is expected that 0.27 tpd of PM and 0.091 tpd of VOC (132 tons per year) emission reductions can be achieved by installing a catalytic oxidizer, assuming an 83% removal efficiency for PM and 86% removal efficiency for VOC. The cost-effectiveness to reduce emissions from all chain-driven charbroilers in the Bay Area is \$6,837 per ton of PM and VOC reduced.

Wet Scrubbers

Capital Costs: A wet scrubber unit has a capital cost of \$27,025 that includes an estimated installation cost of \$2,000. The unit contains all the components and accessories to operate at 2,000 cfm, including surfactant feeder, controller, remote start/stop control, re-circulation pump, valves, and exhaust blower.

Operating Costs: Annual O & M costs are anticipated to not exceed \$2,000. O&M includes the energy cost for operating the controller and exhaust blower as well as the monthly expense of purchasing non-foaming surfactants detergent.

The total annualized cost of installing this control, including O&M, is \$5,838. PM removal efficiencies of 90% or higher have been achieved at restaurants in which wet scrubbers were installed as the control device. Based on the estimates of 0.34 tpd of PM emissions, it is expected that 0.29 tpd of PM emission reductions can be achieved. The cost-effectiveness to reduce emissions from a chain-driven charbroiler by installing a wet scrubber is \$24,558 per ton of PM reduced.

Electrostatic Precipitators

Capital Costs: Manufacturers provided a range of costs for a double pass electrostatic precipitator (ESP) with ducting, exhaust fan, and one set of replacement plates: \$20,000 for a ventilation rate of 2,000 cfm to \$40,000 for a ventilation rate of 5,000 cfm. The District assumed a cost of \$20,000 for an ESP that operates at a ventilation rate of 2,000 cfm, which is sufficient ventilation for single chain-driven charbroiler unit. The District also included additional costs for installing optional equipment designed to enhance the performance and operation of the electrostatic precipitator and reduce the overall maintenance costs:

- First pass autowash module, including timer, to automatically wash the plates - \$4,000

- Outdoor weather package to insulate and weatherproof the unit if it is installed on the roof of the restaurant - \$4,000
- Advanced hood filters in the hood system that capture 55% to 60% of the large particles and consequently reduces the cleaning frequency of the plates - \$1,500.

A hot water line, drain, and wiring to the timer would be installed to support the automatic wash system at a cost of \$7,500. The total capital cost for installing the ESP with automatic wash is estimated at \$37,000. This cost is relatively high based on the additional options that were included in the cost estimate. Restaurants may purchase a single pass electrostatic precipitator without any additional enhancements for about \$20,000.

Operating Costs: Annual O&M costs are anticipated not to exceed \$1,480. The ESP unit itself uses minimal energy, equivalent to that used by a 60 watt light bulb. However, industry representatives have stated that O & M costs will vary depending on the options that are installed in the unit at the time of purchase.

A self-cleaning ESP with automatic water wash requires some additional cleaning of the plates and inside housing to ensure optimal performance. The automatic washing unit requires approximately one (1) gallon of detergent for each plate per week at a cost ranging from \$9 to \$18 per gallon. If the automatic wash cycle is not installed, then one to two gallons of detergent is sufficient to soak and clean the plates per month.

A restaurant owner can either contract with a cleaning service or perform the maintenance and cleaning of the ESP themselves. A cleaning service will remove the first pass of plates; insert clean plates; soak, clean, and store the used plates; and power-wash the housing of the ESP using manufacturer's approved detergent, at a cost ranging from \$303 to \$920 per month.

Restaurants that choose to clean the ESP themselves, may soak the plates overnight and install a second set of plates while the first set is being washed for a cost of \$123 per month, which includes the cost of the detergent for the autowash unit. If the restaurant opts to install more efficient hood filters, then the cleaning frequency and, thus, the cost of cleaning, can be reduced by half.

Restaurant owners may also purchase optional odor control units that will increase the cost of the unit by at least \$1,000 and the operating cost by at least \$10,000 per year. For this assessment, staff estimated costs for operating a double pass electrostatic precipitator without an odor control unit where the plates are cleaned in-house and advanced hood filters have been installed.

The total annualized cost of installing this control, including O&M, is \$6,734. An ESP has a 90% collection efficiency for PM. It is expected that 0.29 tpd of PM (total of 105 tons per year) emission reductions can be achieved. The cost-

effectiveness to reduce emissions by installing an ESP for a chain-driven charbroiler is \$28,329 per ton of PM reduced.

Fiber-Bed Filters

Capital Costs: Fiber bed filter systems have a capital cost of \$25,000 with an estimated installation cost of \$2,500.

Operating Costs: Annual O&M costs of replacing the filter (\$3.18 per cubic feet per minute flow) and utility costs for operating the equipment are \$7,500.

The total annualized cost of installing this control, including O&M, is \$11,405. The filters are capable of removing 90% of PM emissions. Based on the estimates of 0.34 tpd of PM emissions, it is expected that 0.29 tpd of PM (total of 105 tons per year) emission reductions can be achieved. The cost-effectiveness to reduce emissions by installing fiber-bed filters for a chain-driven charbroiler is \$47,980 per ton of PM reduced.

Thermal or Direct-fired Incineration

Capital Costs: Manufacturers estimated a cost of \$25,000 for the incineration unit plus an additional \$6,350 for the installation.

Operating Costs: The unit requires 26 therms of natural gas per hour to operate. Using a rate of \$0.63 cents per therm and assuming 16 hours of operation for 365 days per year, the annual O & M cost is \$95,659.

The total annualized cost of installing this control including O & M is \$100,111. PM and VOC removal efficiencies range from 95% to 99.9% depending upon the temperature, residence time, and mixing inside the incinerator. Assuming a removal efficiency of 95%, a total PM and VOC emission reduction of 0.40 tpd (148 tons per year) is expected. The cost-effectiveness is approximately \$303,761 per ton of PM and VOC reduced from a chain-driven charbroiler.

Table 4. Annual Cost for Controls on Chain-driven Charbroilers

Control for Chain-driven Charbroiler	Capital Cost for Equipment and Installation (Dollars)	Annualized Capital Cost (Dollars per year)	Annual Recurring O&M Costs (Dollars per year)	Total Annual Cost (Dollars per year over 10 years)
Catalytic Oxidizer	\$9,000	\$1,278	\$750	\$2,028
Wet Scrubber	\$27,025	\$3,838	\$2,000	\$5,838
Electrostatic Precipitators	\$37,000	\$5,254	\$1,480	\$6,734
Fiber Bed Filters	\$27,500	\$3,905	\$7,500	\$11,405
Thermal Incinerator	\$31,350	\$4,452	\$95,659	\$100,111

Table 5. Cost Effectiveness of Potential Controls on Chain-driven Charbroilers

Control for Chain-driven Charbroiler	Total Annual Cost (Dollars per year over 10 years)	Total PM and VOC Emission Reduction (Tons per year)	Number of Chain-Driven Charbroilers	Cost-Effectiveness (Dollars per ton of VOC and PM removed)
Catalytic Oxidizer	\$2,028	132	443	\$6,837
Wet Scrubber	\$5,838	105	443	\$24,558
Electrostatic Precipitators	\$6,734	105	443	\$28,329
Fiber Bed Filters	\$11,405	105	443	\$47,980
Thermal Incinerator	\$100,111	148	443	\$303,761

Under-fired Charbroilers

As described in Section III, the District evaluated the technical feasibility, potential emission reductions, and costs of installing an ESP, thermal incinerator, wet scrubber, or HEPA filter to control particulate matter emissions from under-fired charbroilers. Table 6 presents a summary of the total annual cost for installing and maintaining the equipment, and Table 7 presents the cost-effectiveness. Catalytic oxidizers, designed to fit directly on top of a chain-driven charbroiler, have not been developed for under-fired charbroilers. The currently available control options for an under-fired charbroiler are more expensive although under-fired charbroilers produce more emissions. For this reason, the proposal to control under-fired charbroilers is focused on restaurants with large grills (equal to or greater than 10 square feet) that purchase 1000 lbs. of beef per week rather than 500 and grills 800 lbs. of beef per week.

HEPA Filters

Capital Costs: HEPA filters have a capital cost of \$35,000 for a 3,000 cfm unit and an estimated installation cost of \$2,000.

Operating Costs: The annual O&M costs are anticipated to not exceed \$3,000. HEPA filter units use a filter module that consists of three filters placed in series. The first filter is called a pre-filter that is fully disposable pleated filter that cost \$6 per filter and must be replaced every four (4) weeks. The second filter is a medium filter that is a fully disposable bag filter that cost approximately \$10 per filter and is replaced every eight (8) weeks. The final filter is a fully disposable 12 inch HEPA filter that costs \$200 per filter and is replaced every six (6) months.

The total annualized cost of installing this control, including O&M, is \$8,254. It is expected that 95% of PM may be captured using this control device. Based on estimate of 0.31 tpd of PM emissions from restaurants affected by the proposal, the PM emission reduction is anticipated to be 0.29 tpd (total of 107 tons per year). The cost-effectiveness to reduce emissions by installing HEPA filters to control an under-fired charbroiler is \$17,306 per ton of PM reduced.

Electrostatic Precipitators

Capital Costs: Manufacturers provided a range of costs for a double pass electrostatic precipitator (ESP) with ducting and exhaust fan of \$20,000 for a ventilation rate of 2,000 cfm to \$40,152 for a ventilation rate of 5,000 cfm. For this assessment of the costs to control an under-fired charbroiler, a maximum ventilation rate of 4,000 cfm was used. This ventilation rate is typical required for a large under-fired charbroiler. The cost of an ESP that operates at this ventilation rate is \$27,500. Installation costs are site-specific and will vary depending on given local building codes. The District calculated costs for a 4,000 cfm ESP that includes an automatic wash system, outdoor weather package, more efficient hood filters, plumbing for a hot water line and drain, and electrical wiring for the autowash system. The total capital cost is estimated to be \$44,500. However, the cost of the electrostatic precipitator may be as low as \$20,000, if fewer options were installed, or may be higher if the ESP must accommodate a higher ventilation rate.

Operating Costs: The annual O&M cost is anticipated not to exceed \$2,480. The ESP is assumed to be serviced in-house including cleaning and the plates and power-washing the housing. Detergent costs are estimated at \$2,000 per year. For more information regarding O&M costs for an ESP, see the discussion of electrostatic precipitator operating costs under the heading "Chain-Driven Charbroilers," above.

The total annualized cost of installing this control, including O&M, is \$8,799.

ESPs will remove 90% of PM. Based on the estimates of 0.31 tpd of PM emissions from restaurants subject to this rule, it is expected that 0.28 tpd of PM (total of 102 tons per year) emission reductions can be achieved. The cost-effectiveness to reduce emissions by installing an ESP on an under-fired charbroiler is \$19,468 per ton of PM reduced. If a restaurant chooses to contract with a service company for monthly cleaning of the plates and housing, the cost-effectiveness can be as high as \$37,847 per ton of PM removed. ESPs that are installed without the autowash system and are cleaned nightly by restaurant personnel have a cost-effectiveness of \$11,899 per ton of PM.

Wet Scrubbers

Capital Costs: A wet scrubber unit has a capital cost of \$30,452 for a system that operates at 3,000 cfm, and an estimated installation cost of \$6,266. The costs include all components and accessories necessary for the complete operation of the unit.

Operating Costs: The annual O&M cost is anticipated to not exceed \$6,582. This O & M cost estimate includes the energy cost for operating the controller and exhaust blower, as well as the monthly expense of purchasing non-foaming surfactants detergent.

The total annualized cost of installing this control including O&M is \$11,796. Although wet scrubbers have achieved PM removal efficiencies of 90% at restaurants in the South Coast Air Quality Management District, wet scrubbers are not commonly used in restaurants located in the Bay Area. Based on the estimates of 0.31 tpd of PM emissions from mixed meats, it is expected that 0.28 tpd of PM (total of 102 tons per year) emission reductions can be achieved. The cost-effectiveness to reduce emissions by installing a wet scrubber on an under-fired charbroiler is \$26,098 per ton of PM reduced.

Thermal or Direct-fired Incineration

Capital Costs: Manufacturers estimated a cost of \$25,000 for the incineration unit plus an additional \$6,350 for the installation.

Operating Costs: The unit requires 26 therms of natural gas per hour to operate. Using a rate of \$0.63 cents per therm and assuming 16 hours of operation for 365 days per year, the annual O&M cost is \$95,659.

The total annualized cost of installing this control, including O&M, is \$100,111. PM and VOC removal efficiencies range from 95% to 99.9% depending upon the temperature, residence time, and mixing inside the incinerator. Assuming a removal efficiency of 95%, a total PM and VOC emission reduction of 0.43 tpd (158 tons per year) is expected from restaurants subject to this proposal. The cost-effectiveness is approximately \$142,588 per ton of PM and VOC reduced.

Table 6. Annual Cost for Controls on Under-Fired Charbroilers

Control for Chain-driven Charbroiler	Capital Cost for Equipment and Installation (Dollars)	Annualized Capital Cost (Dollars per year)	Annual Recurring O&M Costs (Dollars per year)	Total Annual Cost (Dollars per year over 10 years)
HEPA Filters	\$37,000	\$5,254	\$3,000	\$8,254
Electrostatic Precipitators	\$44,500	\$6,319	\$2,480	\$8,799
Wet Scrubber	\$36,718	\$5,214	\$6,582	\$11,796
Thermal Incinerator	\$31,350	\$4,452	\$95,659	\$100,111

Table 7. Cost Effectiveness of Proposed Controls on Under-Fired Charbroilers

Control for Chain-driven Charbroiler	Total Annual Cost (Dollars per year over 10 years)	Total PM Emission Reduction (Tons per year)	Number of Under-Fired Charbroilers*	Cost-Effectiveness (Dollars per ton of VOC and PM removed)
HEPA Filters	\$8,254	107	225	\$17,306
Electrostatic Precipitator	\$8,799	102	225	\$19,468
Wet Scrubber	\$11,796	102	225	\$26,098
Thermal Incinerator	\$100,111	158	225	\$142,588

*Includes 25 additional under-fired charbroilers from new construction in the first year.

C. Incremental Cost Effectiveness

Section 40920.6 of the California Health and Safety Code requires an air district to perform an incremental cost analysis for any proposed Best Available Retrofit Control Technology rule or feasible measure. The air district must: (1) identify one or more control options achieving the emission reduction objectives for the proposed rule, (2) determine the cost effectiveness for each option, and (3) calculate the incremental cost effectiveness for each option. To determine incremental costs, the air district must “calculate the difference in the dollar costs divided by the difference in the emission reduction potentials between each progressively more stringent potential control option as compared to the next less expensive control option.”

To determine incremental costs, the District compared the cost-effectiveness of each control device presented in Table 5 for chain-driven charbroilers and Table 7 for under-fired charbroilers. Table 8 presents a summary of the incremental cost-effectiveness associated with the proposed regulation.

As shown in Table 8, the catalytic oxidizer is the most cost-effective control device for chain-driven charbroiler. The cost-effectiveness of the other control technologies ranges from \$24,558 to \$303,761 per ton of PM removed. In addition, the catalytic oxidizer operates without an external energy supply since it uses the heat generated from the cooking process to activate the catalyst. The catalyst also radiates heat back to the charbroiler, and as a result, less energy is required to operate the charbroiler. Although the proposed standard essentially allows the use of any of the control technologies listed in Table 8, the proposed standard is based on the use of a catalytic oxidizer.

For under-fired charbroilers, ESPs and HEPA filters are the most cost-effective control devices for controlling PM emissions. The wet scrubber is also a viable control option to restaurant owners given its proven control efficiencies in other industries. The thermal incinerator has substantially higher costs to operate.

Table 8. Incremental Cost Effectiveness of Proposed Controls on Charbroiler

Type of Charbroiler	Control	Cost-Effectiveness (Dollars per ton of VOC and PM removed)	Incremental Cost Effectiveness (PM only)
Chain-Driven Charbroiler	Catalytic Oxidizer	\$6,837	\$0.0
	Wet Scrubber	\$24,558	\$17,721
	Electrostatic Precipitator	\$28,329	\$21,492
	Fiber Bed Filters	\$47,980	\$41,143
	Thermal Incinerator	\$303,761	\$296,924
Under-Fired Charbroiler	HEPA Filters	\$17,306	\$0.0
	Electrostatic Precipitator	\$19,468	\$2,162
	Wet Scrubber	\$26,098	\$10,049
	Thermal Incinerator	\$142,588	\$126,539

D. District Staff Impacts

Currently, the District does not regulate emissions from restaurants except on a nuisance or smoke basis. Implementing this rule will require District resources from several divisions including Compliance and Enforcement, Engineering, and Administration. The actual personnel involved will likely involve air quality inspectors; an air quality technician to coordinate development of the web-based registration system, review registrations, and answers questions from the public; engineers to review the manufacturer’s certification and testing procedures; a program analyst to design the web-based registration and maintain the registration database; and an accountant to process registration and fees.

In the first year after adoption, the proposal calls for all owners and operators of restaurants that have chain-driven charbroilers and that purchase at least 500 pounds of beef and cook at least 400 pounds of beef on the charbroiler to install a catalytic oxidizer or alternative control device certified for use under the rule. There are approximately 443 chain-driven charbroilers currently operating in the Bay Area that would be subject to this proposed rule. The District anticipates that an inspection should require no more than 100 minutes for each restaurant including drive time and paperwork. Given the number of restaurants, inspection time would be about 739 hours in the first year which is equivalent to 0.36 full-time employees (FTE), at a cost of \$77,040 for an air quality inspector.

This proposal would be the first District rule to require web-based registration. In order to develop this system, a program analyst and an air quality engineer will be required to develop the registration form, maintain the registration database, review registrations, and respond to public inquiries. This is estimated to cost approximately \$45,800 (0.21 FTE). Because many catalytic oxidizers have already been approved by the South Coast air district for control of chain-driven charbroilers, no more than \$5,260 (0.02 FTE for a Principal Engineer) would be required to review manufacturers' certifications.

Starting two years after the rule is adopted, owners and operators of restaurants that have newly-installed under-fired charbroilers with a total of at least ten square feet of grill surface area would have to install and operate a control device if the restaurant purchases at least 1,000 lbs. of beef and cooks at least 800 lbs. of beef on the charbroiler. In five years, all restaurants with under-fired charbroilers totaling at least ten square feet of grill surface area that are subject to the proposed rule would be required to install a control device. There are currently 489 restaurants in the Bay Area that have under-fired charbroilers totaling at least 10 square feet of grill surface area. The rule would apply to approximately 200 of these restaurants. Inspections are anticipated to cost \$23,219 based on 217 hours per year (0.11 FTE, Air Quality Inspector). Maintenance of the web-based registration system will cost \$11,235 (0.05 FTE, Air Quality Engineer). Review of the certifications provided by control device manufacturers expected to cost \$15,770 (120 hours or 0.06 FTE, Principal Air Quality Engineer).

In total, the District is anticipated to incur a cost of approximately 0.81 FTE per year in the first five years to implement this proposed rule based on the estimates above. To recover costs, a registration fee of \$360 and annual recurring fee of \$100 is proposed. The fee schedule for restaurants in Regulation 3, Schedule R is proposed to be revised to reflect the current proposed Regulation 6, Rule 2.

E. Socioeconomic Impacts

Section 40728.5 of the Health and Safety Code requires an air district to assess the socioeconomic impacts of the adoption, amendment, or repeal of a rule if the rule is one that "will significantly affect air quality or emissions limitations."

Applied Economic Development, Berkeley, California, has prepared a socioeconomic analysis. The analysis concludes that the affected restaurants should be able to absorb the costs of compliance with the proposed rule without significant economic dislocation or loss of jobs. The socioeconomic analysis is attached as Appendix D.

VII. ENVIRONMENTAL IMPACTS

Pursuant to the California Environmental Quality Act, the District has had an initial study for the proposed amendments prepared by Environmental Audit, Inc. The initial study concludes that there are no potential significant adverse environmental impacts associated with the proposed amendments. A negative declaration is proposed for adoption by the District Board of Directors. The initial study and negative declaration have been circulated for public comment, and no comments were received.

VIII. REGULATORY IMPACTS

Section 40727.2 of the Health and Safety Code requires an air district, in adopting, amending, or repealing an air district regulation, to identify existing federal and district air pollution control requirements for the equipment or source type affected by the proposed change in district rules. The district must then note any differences between these existing requirements and the requirements imposed by the proposed change.

Adoption of this rule would not conflict with any existing federal or District requirement. Under the federal air pollution requirements, there is no rule that limits emissions from restaurants. The District also does not have any rules that are applicable to restaurants except those of general applicability such as Regulation 1, Section 301: Public Nuisance and Regulation 6: Particulate Matter.

IX. RULE DEVELOPMENT PROCESS

District staff has undertaken a comprehensive public outreach program to involve all stakeholders in developing this proposal, including individual restaurant owners, hood manufacturers, restaurant trade organizations and industry representatives, county health departments, and vendors and installers of commercial kitchen appliances.

The District started the rule development process in January 2005. At that time, the District contacted the SCAQMD to receive copies of all research documents and staff reports that were produced in support of SCAQMD Regulation 1138. The District then contacted the health departments of all the counties in the District in March 2005 and December 2005, to request an inventory of currently permitted restaurants and to apprise the counties of the District's intent to consider restaurant controls. The District held two meetings with county health

officials, one on January 19, 2006, and another on July 28, 2006. The purpose of the meetings was to discuss the current emission inventory, solicit suggestions for ways to control emissions, and development of a cooperative enforcement strategy between the District and the various counties.

The District also initiated contact with the Golden Gate Restaurant Association in February 2006 to invite their participation in the rule development process. The District met with representatives of the Golden Gate Restaurant Association on February 24, 2006, and had follow-on telephone discussions as the rule evolved.

District staff contacted the PG&E Food Service Technology Center in San Ramon, California in May 2006 regarding emission factors for specific types of commercial cooking equipment. After conducting a site walk of their facility, District staff has been in continuous discussions with representatives from the Food Service Technology Center in developing this proposal. The Center represents the interests of the restaurant industry and kitchen ventilation hood manufacturers. The Center is also a clearing house for commercial kitchen equipment performance and has expertise in commercial kitchen ventilation and building energy efficiency.

District staff also verified the emission inventory by conducting source tests on four restaurants in the Bay Area. District staff tested two restaurants that operated either a chain-driven charbroiler or under-fired charbroiler that exhausted their emissions through a control device. For comparison purposes, the District also collected particulate matter samples from two restaurants that operated either a chain-driven charbroiler or under-fired charbroiler without any control device. The emission estimates were used to determine emission standards in the proposed rule.

In October 2006, in advance of public workshops held in November 2006, District staff published the draft regulation and provided a workshop report explaining the proposed regulation. The first draft of Regulation 6, Rule 2, and the workshop report were posted on the District web site and e-mailed to stakeholders on October 16, 2006. Simultaneous to the posting on the District web site, the District sent out approximately 17,000 postcards to individual restaurant owners, hood vendors, and installers informing them of the rule and the then-upcoming public workshop. The District also developed a rule summary fact sheet that was translated to Chinese and Spanish and made available on the District web site.

Once the regulation was posted, the District received and responded to more than 20 telephone inquiries and e-mails regarding specific topics and issues about the draft rule and workshop report.

The District held four (4) public workshops on November 14 and 15, 2006, in San Francisco, San Jose, Oakland, and Vallejo to solicit comments from public, members of county health departments, industry organizations, and other

interested parties on the proposed rule. A total of approximately 20 people attended these workshops, with most of the interested parties being hood manufacturers, a restaurant organization, and independent local restaurants. The District received written comments from hood manufacturers that were identical to comments provided by the restaurant organization.

Overall, the public comments supported the standard for chain-driven charbroilers. Input from the first workshop raised concerns about the technical feasibility and costs of installing high efficiency filters, a modest control, in all restaurants that operate a Type I hood. There was disagreement within the industry regarding the effectiveness of high efficiency filters. The trade organization did not support the installation of controls on restaurants that utilize low emission cooking equipment. Another comment suggested that the rule would result in more energy consumption and additional greenhouse gas emissions.

After the November public workshops, the District continued discussions with hood manufacturers and trade organizations regarding ways to revise the proposal. These interactions lead directly to developing a second draft of Regulation 6, Rule 2 to address emissions from only charbroilers. A supplement to the workshop report was generated to summarize the differences from the original proposal. The District presented the revised proposal before the American Society of Heating, Refrigeration, and Air-Conditioning Engineers (ASHRAE) Technical Committee 5.10 Kitchen Ventilation on January 27, 2007. The second workshop notice and revised rule were posted on the District website and e-mailed to all interested parties. The second workshop was held on March 6, 2007.

Input from the second workshop was focused primarily on removing certain requirements intended to promote energy efficiency and on the cost-effectiveness of control technologies. One set of comments requested that the District lower the effective grill size from 10 square feet to six (6) square feet and include a provision to regulate emissions from griddles. Staff used input received from the second workshop to develop the final draft of the proposed regulation that is published as a companion to this Staff Report for comments on April 2, 2007.

On May 16, 2007 an initial public hearing was conducted by the Board of Directors on proposed Regulation 6, Rule 2. Comments and questions at the hearing addressed issues including: the number of restaurants with charbroilers larger than 10 square feet; emissions from meats other than beef; and potential impacts to small businesses. The District Board directed staff to do additional research and referred the rule to the Stationary Source Committee.

Staff conducted a survey of Bay Area restaurants, focusing on the grill size and amounts and types of meats cooked on under-fired and chain-driven

charbroilers. District inspectors interviewed a representative sample of over 400 randomly selected restaurants from all nine Bay Area counties. The survey verified that the grill size specified in the rule focuses control requirements on large, high-production restaurants that represent approximately 4% of the restaurants that operate an under-fired charbroiler. In addition, staff has further investigated emissions from various types of meats and costs to operate and maintain control technologies. District staff also met with representatives from the Golden Gate Restaurant Association on June 14, 2007 and July 25, 2007, and with a representative from the California Restaurant Association on August 11, 2007.

Based on the findings from the survey and meetings with restaurant associations, the proposed rule was revised to focus control requirements on those restaurants that purchase and grill large quantities of beef. District staff revised the proposed Regulation 6, Rule 2 and held a workshop on the revised proposal on October 23, 2007.

The District sent approximately 13,300 postcards to Bay Area restaurants to notify them of the revised proposal and the public workshop. Comments at the workshop and in subsequent letters primarily focused on questions concerning the certification testing procedures to demonstrate compliance with the emission standard. One commenter noted the lack of a testing procedure in the proposed rule for new catalytic oxidizers and a question was asked about how a restaurant would demonstrate an exemption under the proposed rule. The proposed rule has been restructured based on these comments such that catalytic oxidizers certified by the SCAQMD are acceptable for installation in the Bay Area. The certification testing procedures have been revised for consistency with the definitions and the emission standards. Compliance advisories can provide guidance on how to demonstrate an exemption. A letter supporting the proposed rule was submitted by the San Francisco Department of Public Health.

The District will continue to follow the development of cost effective control technologies for existing under-fired charbroilers and provide technical updates to the Board of Directors.

X. FUTURE RESEARCH

Emissions from restaurant operations currently make up over 6% of all PM₁₀ emissions in the Bay Area. This rule is an important first step in achieving emission reductions from a source category that has not been regulated in the past. District staff is committed to working with industry representatives and to provide the Board of Directors with periodic updates on the development of control technology for under-fired charbroilers. This rule is an opportunity for hood manufacturers, abatement equipment manufacturers, and cooking equipment manufacturers and vendors to work together in developing new and adapting existing technologies.

Catalytic oxidizers, a highly cost-effective and virtually maintenance-free control device for chain-driven charbroilers were developed in response to the SCAQMD Regulation 1138, adopted in 1997. Because the SCAQMD rule did not regulate under-fired charbroilers, there has been limited research and development directed at control technologies for these cooking devices. A regulatory mandate will help to create a market for under-fired charbroiler abatement technology. For this reason, the compliance date for existing under-fired charbroilers is set five years in the future, to allow time for development of better, more cost-effective technologies.

The proposed rule is only the first step in an ongoing commitment to reduce emissions from commercial cooking appliances. As additional data becomes available, District staff will be evaluating possible controls on other types of cooking equipment, including griddles, woks, and wood-fired cooking appliances. There are over 7,000 griddles that operate in the Bay Area that, collectively, are responsible for about 14% of commercial cooking emissions. Studies conducted on wok cooking indicate woks emit a number of toxic compounds from volatilization and partial combustion of the cooking oils. Combustion of wood in wood-fired cooking appliances produces the same emissions as wood stoves and fireplaces and occurs much more frequently than residential wood burning. District investigation into possible controls on these and other types of cooking equipment will be part of efforts to reduce PM emissions in order to achieve state PM standards and (if necessary) the new federal 24-hour PM standard.

Staff is interested in further research in this field to support further development of data on emissions from griddles, woks, wood-fired cooking appliances, and other types of cooking appliances. The District will closely monitor research which could be used to refine the emission inventory, assess risk factors, and identify whether additional rule making should be conducted.

XI. CONCLUSION

Pursuant to Section 40727 of the California Health and Safety Code, the proposed rule must meet findings of necessity, authority, clarity, consistency, non-duplication, and reference. The proposed regulation is:

- Necessary to protect public health by reducing ozone precursors and particulate matter emissions to meet the requirements of Senate Bill 656 Particulate Matter Implementation Schedule and further study commitment of the Bay Area 2005 Ozone Strategy;
- Authorized by California Health and Safety Code Sections 40000, 40001, 40702, and 40725 through 40728;
- Clear, in that the new regulation specifically delineates the affected industry, compliance options, and administrative requirements for industry

subject to this rule, so that its meaning can be easily understood by the persons directly affected by it;

- Consistent with other District rules, and not in conflict with state or federal law;
- Non-duplicative of other statutes, rules, or regulations; and
- Implementing, interpreting and making specific the provisions of the California Health and Safety Code sections 40000 and 40702.

The proposed rule has met all legal noticing requirements, has been discussed with the regulated community and other interested parties, and reflects the input and comments of many affected and interested parties. In addition to Regulation 6, Rule 2, fees for registering charbroilers under Regulation 3 would be reduced, and Regulation 6: Particulate Matter and Visible Emissions would be renumbered and renamed for consistency. District staff recommends adoption of proposed Regulation 6, Rule 2: Commercial Cooking Equipment, adoption of proposed amendments to Regulation 3, Schedule R: Equipment Registration Fees, adoption of proposed amendments to Regulation 6: Particulate Matter and Visible Emissions, and adoption of the CEQA Negative Declaration.

XII. REFERENCES

1. England, G.C., Wien, S., Chang, M.C., Gurney, M. D., and Loos, K., 2001. Fine Particle and Precursor Emissions from Power, Oil, and Gas Industry Combustion Sources.
2. Foodservice Consultants Society International North America (FCSI), 2006. FCSI White Paper, Commercial Kitchen Ventilation, "Best Practice" Design and Specification Guidelines, September 2006.
3. Food Service Technology Center. Design Guide 1: Improving Commercial Kitchen Ventilation System Performance. Selecting and Sizing Exhaust Hoods.
4. Hildemann, L.M., Cass, G.R., Markowski, G.R., 1989. A Dilution Stack Sampler for Collection of Organic Aerosol Emissions: Design, Characterization and Field Tests. *Aerosol Sci. Technol.* 10: 193-204.
5. Gerstler, W.D., Kuehn, T.H., Pui, D.Y., Ramsey, J.W., Doerr, M.P., 1996. Identification and Characterization of Effluents from Various Cooking Appliances and Processes as Related to Optimum Design of Kitchen Ventilation Systems. ASHRAE 745-RP, Phase I, Final Report. Dated June 13, 1996.
6. Gerstler, W.D., Kuehn, T.H., Pui, D.Y., Ramsey, J.W., Rosen, M., Carlson, R.R., and Petersen, S.D., 1999. Identification and Characterization of Effluents from Various Cooking Appliances and Processes as Related to

- Optimum Design of Kitchen Ventilation Systems. ASHRAE 745-RP, Phase II, Final Report. Dated February 9, 1999.
7. Gerstler, W.D., 2002. New Rules for Kitchen Exhaust. American Society of Heating, Refrigerating, and Air-Conditioning Engineers, Inc. (ASHRAE) Journal. Downloaded from www.ashraejournal.org. Dated November 2002.
 8. Kuehn, T.H., Olson, B.A., Ramsey, J.W., Friell, J., and Rocklage, J., 2004. Development of a Standard Method of Test for Commercial Kitchen Effluent Grease Removal Systems. Draft Final Report. Reported conducted by the University of Minnesota, Department of Mechanical Engineering, Minneapolis, MN for Nickel-Fisher, Inc. Food Service Technology Center, San Ramon, CA. Dated July 31, 2004.
 9. MacDonald, J.D., Zielinska, B., Fujita, E.M., Sagabiel, J.C., Chow, J.C., and Watson, J.G., 2003. Emissions from Charbroiling and Grilling of Chicken and Beef. J. Air & Waste Manage. Assoc. 53: 185-184. February 2003.
 10. National Fire Protection Association, Inc. (NFPA), 2004. NFPA 96 Standard for Ventilation Control and Fire Protection of Commercial Cooking Operations. 2004 Edition.
 11. Pacific Environmental Services, Inc., 1999. Final Report. A Detailed Survey of Restaurant Operations in the South Coast Air Basin. Submitted to South Coast Air Quality Management District on February 5, 1999. Contract No. 98089.
 12. Public Research Institute, 2001. Charbroiling Activity Estimation. Prepared for the California Air Resources Board and the California Environmental Protection Agency. Dated June 30, 2001.
 13. San Joaquin Valley Unified Air Pollution Control District, 2001. Draft Staff Report. Commercial Charbroiling. Dated October 27, 2001.
 14. Sherer, M., 2003. Special Report: Clearing the Air. New Hood and Fan Technologies are Doing a Better Job for Less. Foodservice Equipment Reports. Downloaded from www.fermag.com/sr/v7i6_sr_hood.htm. Dated June 2003.
 15. South Coast Air Quality Management District, 2000. Status Report on Controlling Particulate Matter and Volatile Organic Compound Emissions from Restaurant Operations. Board Meeting Date: August 18, 2000. Agenda No. 20.

16. South Coast Air Quality Management District, 2004. Staff Recommendations Regarding Controlling Emissions from Restaurant Operations. Board Meeting Date: December 3, 2004. Agenda No. 39.
17. University of California Riverside, College of Engineering, Center for Environmental Research and Technology, (CE-CERT) 1999. Development and Demonstration of Emission Control Technologies for Commercial Underfired Broilers. Contract No. 98015, February 1999.
18. University of California Riverside, College of Engineering, Center for Environmental Research and Technology, (CE-CERT) 1997. Further Development of Emission Test Methods and Development of Emission Factors for Various Commercial Cooking Operations. Contract No. 96027, July 1997.
19. University of California Riverside, College of Engineering, Center for Environmental Research and Technology, (CE-CERT) 2002. Assessment of Emissions from a Chain-Driven Charbroiler (Nieco Model 9025, Golden West Equipment, Inc) Using a Catalytic Control Device (Model 7-193), Final Report, for Engelhard Corporation. Dated September 13, 2002.

APPENDIX A EMISSIONS CALCULATIONS

The following sections describe the method used to quantify PM and VOC emissions from broilers for the nine Bay Area counties.

A. Estimated Number of Restaurants with Charbroilers

To obtain an accurate estimate of the total number of commercial restaurants in the District, staff contacted the health and environmental departments from each of the nine Bay Area counties: Alameda, Contra Costa, Marin, Napa, San Francisco, San Mateo, Solano, and Sonoma. County health agencies maintain lists of restaurants and other facilities in order to inspect and regulate food handling practices within the county's jurisdiction. Table A-1 presents the results of the survey. Restaurants situated in the City of Berkeley are under the jurisdiction of the local health department and not regulated by the Alameda County health department. The number of restaurants in the City of Berkeley is included in Table A-1.

Table A-1. Commercial Restaurants by County

County/City	Total Number of Restaurants	Adjusted Total for Commercial Restaurants
Alameda County	3,700	2,651
Contra Costa County	1,989	1,425
City of Berkeley	468	336
Marin County	607	435
Napa County	345	248
San Francisco County	3,997	2,863
San Mateo County	2,018	1,446
Santa Clara County	4,933	3,534
Solano County*	1,146	821
Sonoma County*	1,504	1,078
TOTAL	20,707	14,838

Note: * - The number of restaurants for Solano and Sonoma counties was adjusted based on the percentage of the total population within the District jurisdiction (71.2% for Solano County and 87.7% for Sonoma County).

The initial estimate of 20,707 restaurants in the District includes establishments that do not cook (i.e., delicatessens, ice cream parlors, juice bars, etc), institutional eating facilities (i.e., school cafeterias, lodges, retirement homes), and restaurants that have gone out of business. Because the restaurant names and addresses were not requested as part of the survey, the exact number of facilities that would normally be excluded as "noncommercial" restaurants could not be determined. Pacific Environmental Services (PES) conducted a similar study for the South Coast Air Quality Management District (SCAQMD) in 1999 to

determine the number of commercial restaurants under its jurisdiction and found that on average, approximately 77% of the facilities classified as restaurants were commercial facilities that served food to the general public. The study was based on a restaurant survey conducted in the City of Pasadena, the City of Vernon, and Riverside County where 19.4, 16.7 and 23.9 percent, respectively, of the facilities were not commercial restaurants. In addition, PES also determined that approximately 6.97% of the restaurants have gone out of business since the health department lists were compiled.

Using the results of the PES study, a factor of 0.7163 (0.77 for commercial restaurants multiplied by 0.9303 for open business) was then applied to the total number of restaurants in the District to exclude those facilities from the survey that did not serve food, were not open to the public, or have gone out of business. Rounding all estimates to the next whole number, the final number of commercial restaurants in the District was projected at 14,838.

The PES study further surveyed the type of equipment that was used in the cooking operations of the commercial restaurants. Based on the SCAQMD report, the majority of emissions (87% of PM and 82% of VOC) from cooking operations are generated from chain-driven and under-fired broilers.

Chain-driven broilers consist of conveyORIZED belts that carry meat to a flame area that broils the meat on the top and bottom simultaneously. Under-fired broilers have three components: a heating source, high temperature radiant surface, and slotted grill. The grill holds the meat while it is cooked from radiant heat. The study found that the fraction of facilities in the SCAQMD that operated chain-driven and under-fired broilers based on 95th percent confidence limits (in parenthesis) was:

Under-fired broilers:	0.330 (0.29 – 0.37), or 33%
Chain-driven broilers:	0.0373 (0.0212 – 0.0534), or 4%

A state-wide study conducted by Public Research Institute (PRI) in 2001 for the California Air Resources Board and the California Environmental Protection Agency found that approximately 8% of the restaurants had chain-driven broilers while 45% of the restaurants had under-fired broilers. The PRI study determined a higher average percentage of broilers per restaurant than the PES study mainly due to the fact that the PRI study focused on restaurants thought to conduct more broiling activities than other types of restaurants. Given this bias, District staff considered the PES study results more reflective of the likely representation of broilers in the Bay Area.

The District conducted an independent survey of Bay Area restaurants to verify the findings from the PES study. District inspectors surveyed over 400 randomly selected restaurants in the Bay Area and questioned them on the type of cooking equipment they used, the size of the equipment, and the amount and type of meat that is cooked per week. The Bay Area survey confirmed that the

percentages of restaurants that operate a chain-driven charbroiler and/or under-fired charbroilers are consistent with the PES study findings.

Multiplying by the fraction of broilers determined in the PES study, the estimated number of broilers in the District is (rounding up to the nearest whole number):

Under-fired broilers: 4,897
 Chain-driven broilers: 554

B. Amount and Type of Meat Cooked on Charbroilers

The PES study asked the restaurants to report their average weekly use of hamburger, steaks, poultry (with and without skin), pork and seafood, based on the type of cooking equipment used. The average food throughput for chain-driven broiler and under-fired broiler restaurants is presented in Table A-2.

Table A-2. Average Pounds of Meat Cooked Per Year Per Charbroiler (PES Study)

Type of Food	Chain-driven Broiler (lbs/year)	Under-Fired Broiler (lbs/year)
Hamburger	108,846	7,795
Steaks	9,443	6,474
Poultry with Skin	5,200	15,226
Poultry without Skin	18,413	6,027
Pork	6,932	1,404
Seafood	7,457	5,673
TOTAL	156,291	42,599

In a state-wide phone survey conducted by PRI, the average amount of meat cooked per year varied significantly from the results of the PES study. Table 3 presents the results of the PRI study.

Table A-3. Average Pounds of Meat Cooked Per Year Per Charbroiler (PRI Survey)

Type of Food	Chain-driven Broiler (lbs/year)	Under-Fired Broiler (lbs/year)
Hamburger	41,486	14,049
Steaks	12,281	9,363
Poultry with Skin	7,651	7,485
Poultry without Skin	13,842	9,311
Pork	2,997	7,699
Seafood	6,179	7,416
TOTAL	84,436	55,323

Although both studies had comparable number of responders (543 for PES and

655 for PRI), the major differences between the PES and PRI studies were: (1) the PRI study used computer-assisted telephone interviews instead of PES's use of a self-administered (mail-out) questionnaire; (2) PRI used a more detailed restaurant classification scheme and not all categories of restaurants were surveyed; (3) the PRI study focused on restaurants most likely to use broilers; and (4) PRI surveyed restaurants throughout California while PES investigated restaurants within SCAQMD. Overall, PES had a low response rate with only 12.9% of the restaurants responding to the survey while PRI had a response rate of 41%. Given that PES did not receive any responses from the 210 national chain restaurants in its study area, it is unknown if this would significantly impact their estimated amount of hamburger cooked on chain-driven broilers. (A majority of this type of equipment is utilized by fast food restaurants). It should be noted that PES did receive responses from local chain and fast food restaurants that were not considered "national" chains. PRI received responses from 157 fast food restaurants, which equated to 23.9% of the responders. Based on the broader geographic coverage of the responders and the inclusion of cooking practices from fast food restaurants, District staff considered the results of the PRI study (Table A-3) a more representative estimate of the amount of meat cooked on broilers per year. The Bay Area restaurant responses on the amount of meat purchased per week were not included due to the low response rate (less than 14% of the restaurants responded to the question).

C. Emission Factors from Charbroilers

SCAQMD contracted the University of California Riverside, College of Engineering – Center for Environmental Research and Technology (CE-CERT) in 1997 to develop a test method that estimates emission factors for PM₁₀ and VOC released from various restaurant cooking operations. The resulting study (the "CE-CERT study") included tests conducted for hamburger cooked on under-fired and chain-driven broilers. A subsequent study sponsored by ASHRAE, published in 1999 by Gerstler, et al., from the University of Minnesota, Department of Mechanical Engineering (the "Gerstler study") characterized the effluent emissions from various grease producing cooking processes. The study measured grease particulate and vapor emissions and real time particulate size distributions within the exhaust duct using a sample probe and following US EPA Method 5.

Figure A-1 shows the average grease distribution emitted from each appliance as determined by the Gerstler study. The actual composition of the emitted products is complex and it is difficult to determine the portion of the emissions that are particulates. That is because condensable vapors such as water and grease are present in vapor as well as liquid form. Generally, condensables are vapors in gaseous form at entry into the ventilation hood, but may condense into particulate form (i.e., liquid or solid state) in the duct works, on exiting the exhaust fan, or in the atmosphere. The CE-CERT study included the emissions from condensable vapors into its total particulate emission factor. Because these

vapors behave as gases, they cannot be removed through mechanical filtration. Particulate matter greater than 10 microns in size are generally not emitted into the atmosphere, the CE-CERT study confirmed. Standard baffle filters capture particles coarse particulate, those greater than 10 microns in size. Previous testing conducted by CE-CERT for the SCAQMD showed that the particulate matter emitted was all PM₁₀. US EPA Method 5 measures total particulates, including particulates greater than 10 microns in diameter. Although the rule requires the use of US EPA Method 5 for determining compliance with the emission standard, the effluent stream that will be sampled will only consist of particulates less than 10 microns in diameter because the test protocol requires a baffle filter (as part of standard kitchen exhaust equipment). The heated probe situated at the front of the sampling train will not condense vapors and in turn, skew the test results.

Based on the emission factors from the Gerstler study, the District estimates that Type 1 hoods (hoods with fire suppression built into the exhaust system, required for all cooking appliances in restaurants) capture 1,573 tons per year (4.3 tons per day) of PM greater than 10 micron in size from the nine Bay Area counties. For this report, emissions were estimated for particulates less than PM₁₀ and for VOC.

Figure A-1. Average Grease Distribution by Appliance

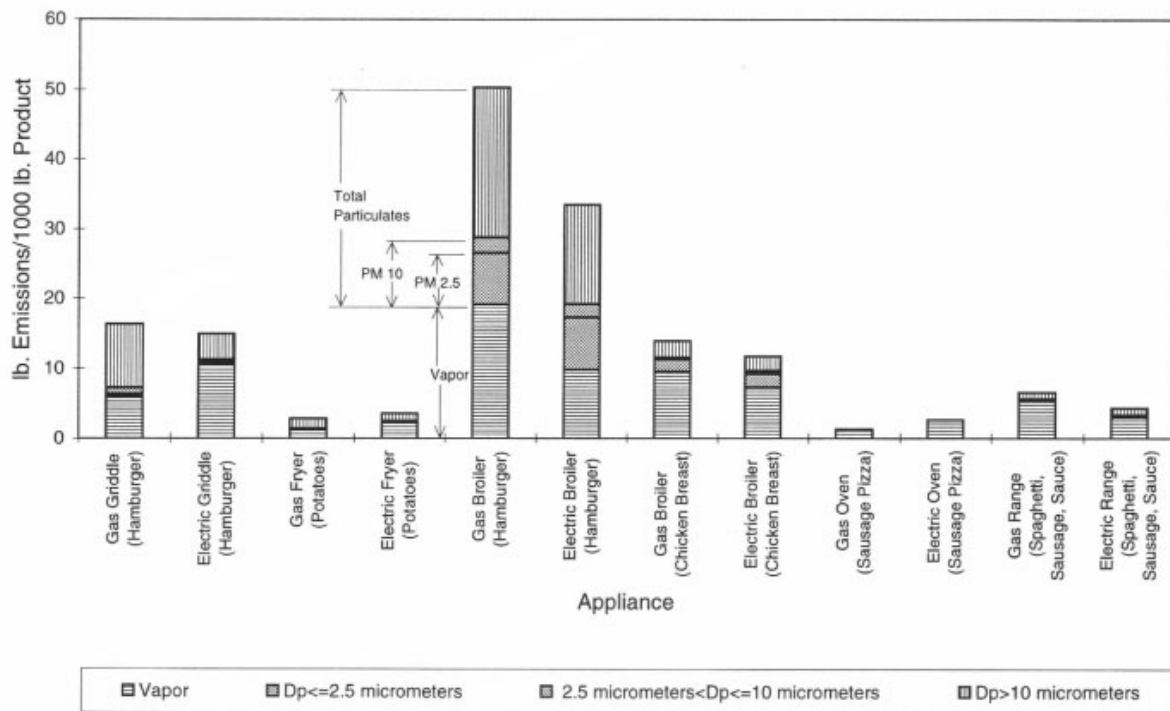

Source: Gerstler et al, 1999

A total of 50 lbs. of emissions is generated from a gas broiler for every 1000 lbs. of hamburger cooked. Based on the Gerstler study, approximately 39% (19 lbs.

for every 1000 lbs. of meat cooked) of the total grease emitted from cooking hamburgers on an under-fired broiler is in the form of condensable vapors. Of the remaining 61% (31 lbs) of grease emissions, 42% (21.5 lbs) of the particulates are greater than 10 microns and 15% (7.3 lbs) of the emissions are less than 2.5 microns in size. Significantly lower emissions are generated from cooking chicken on under-fired broilers due to the very low fat content. The Gerstler study measured only 14 lbs of total grease emissions for every 1000 lbs. of chicken breast cooked. Approximately 69% of the emissions from chicken are in the form of condensable vapors while the remaining 31% are particulates. Table A-4 presents a summary of the emissions factors produced from the Gerstler study.

**Table A-4. PM Emission Factors for Under-Fired Charbroilers
(lbs/1000 lbs of food cooked)**

Type of Food	Under-Fired Broiler	
	PM >10 micron	PM < 10 micron
Hamburger	21.5	9.5
Chicken breast	2.5	2.0

Source: Gerstler et al, 1999

The emission factors for both types of meats from the Gerstler study compared well with previous emission factors determined by the CE-CERT study. It should be noted that the impinger methods used by both studies may create positive mass artifacts that result in higher emissions rates (Hildemann et al., 1999).

A study conducted in 2003 by MacDonald et al., from the Desert Research Institute (DRI) (the "DRI study"), used the same cooking equipment as at CE-CERT to estimate emissions of particulate matter less than 2.5 microns. The DRI study collected samples from a stainless steel dilution tube, rather than an impinger, because: (1) doing so allowed a broader range of sampling media and methods to be employed; and (2) the conditions experienced by the sample more closely match those experienced by the exhaust gas leaving the vent as they mix with the atmosphere (England et al., 2001). Hildemann et al., (1989) found that run-to-run variability is typically large using traditional impinger test methods due to the presence of random non-combustion generated particles that lead to artifact formation in the liquid impingers. Artifacts result in a large positive bias in the condensable particle measurement using traditional methods (England et al., 2001). Unfortunately, the DRI study only quantified emissions for particulates less than 2.5 micron and a portion of condensable vapors that solidified in the dilution tube. For this reason, the DRI emission factors are not directly comparable to either those of the CE-CERT study or the Gerstler study.

Thus, District staff used the emission factors from the Gerstler study to estimate emissions of PM₁₀ from under-fired charbroilers. Because the Gerstler study did not test chain-driven charbroilers or determine emissions factors for VOC, District

staff used emission factors developed in the CE-CERT study to estimate PM and VOC emissions from chain-driven charbroilers, and VOC emissions from under-fired charbroilers. For the chain-driven charbroiler, emission factors for poultry, pork, and seafood were estimated by applying the meat-specific ratios, determined by comparing the emission factors for each meat to hamburgers, for the under-fired charbroiler to the hamburger emission factor for chain-driven charbroiler, which is the only meat that was tested. Under-fired emission factors for chicken breast were used to estimate emissions from pork and chicken with and without skin cooked on under-fired broilers. District staff used emission factors for seafood developed in the CE-CERT study, because the Gerstler study did not develop any such emission factors. The final emission factors used in this study are presented in Table A-5.

Table A-5. Emission Factors (lbs/1000 lbs of food cooked)

Type of Food	Chain-driven Charbroiler		Under-Fired Charbroiler	
	PM10 (b)	VOC (b)	PM10 (a)	VOC (b)
Hamburger	7.42	2.27	9.5	3.94
Steaks	7.42 (c)	2.27 (c)	9.5 (c)	3.94 (c)
Poultry with Skin	1.56 (e)	1.05 (e)	2	1.82
Poultry without Skin	1.56 (e)	1.05 (e)	2 (d)	1.82 (d)
Pork	1.56 (e)	1.05 (e)	2 (d)	1.82 (d)
Seafood	2.58 (e)	0.22 (e)	3.3 (b)	0.38

Note:

a: Emission factors are taken from Gerstler et al study.

b: Emission factors are taken from CE-CERT study.

c: Emissions factors for hamburger were applied to beef steaks since these meats were not tested on this equipment.

d: Emission factors for chicken breast were applied to chicken with/without skin, and pork

e: Emission factors were estimated using factors for meats cooked on under-fired charbroiler

D. Emission Inventory for Charbroilers

The emission inventory for chain-driven and under-fired broilers is estimated by multiplying the number of broilers by the average amount of meat cooked and the emission rates using the following relationship:

$$EM = \frac{EF \times E_{all} \times M}{2000 \text{ lbs/ton}}$$

Where:

EM = Emission inventory from broilers (tons/year);

EF = Emission factor (lbs of PM10 or VOC/1000 lbs of meat cooked);

E_{all} = Total number of broilers in District (unitless); and

M = Average pounds per year of meat cooked on one broiler.

Table A-6 presents the final estimated emissions of PM₁₀ and VOC for broilers.

Table A-6. Emissions from Broilers

Type of Food	Chain-driven Broiler		Under-Fired Broiler	
	PM10 (tons/yr)	VOC (tons/yr)	PM10 (tons/yr)	VOC (tons/yr)
Hamburger	85.3	26.1	327	136
Steaks	25.2	7.72	218	90.3
Poultry with Skin	3.31	2.22	37	33.4
Poultry without Skin	5.99	4.02	45.6	41.5
Pork	1.30	0.87	37.7	34.3
Seafood	4.41	0.37	59.9	6.90
Total (tons/year)	126	41	724	342
Total (tons/day)	0.34	0.11	2.0	0.94

APPENDIX B

South Coast Air Quality Management District

Protocol

**Determination of Particulate and Volatile Organic Compound
Emissions from Restaurant Operations**

SOUTH COAST AIR QUALITY MANAGEMENT DISTRICT

- PROTOCOL -

**DETERMINATION OF PARTICULATE AND VOLATILE ORGANIC COMPOUND
EMISSIONS FROM RESTAURANT OPERATIONS**

November 14, 1997

**SOURCE TESTING AND ENGINEERING BRANCH
APPLIED SCIENCE AND TECHNOLOGY**

RESTAURANT TESTING PROTOCOL

TABLE OF CONTENTS

TABLE OF CONTENTS.....	ii
1.0 OVERVIEW AND APPLICABILITY.....	1
2.0 DEFINITIONS.....	4
3.0 SAMPLING AND ANALYTICAL METHODS	5
3.1 Particulate Matter.....	5
3.2 Volatile Organic Compounds	5
3.3 Flow Rate & Process Weight.....	7
4.0 TESTING PROCEDURES.....	9
4.1 Set-Up.....	9
4.2 Pre-Test.....	9
4.3 Test.....	9
4.4 Post-Test	10
5.0 CALCULATIONS.....	11
5.1 Process Weight Calculations.....	11
5.2 Particulate Matter Calculations.....	11
5.3 Pounds per Day Calculations.....	12
5.4 Efficiency of the Control Device.....	12
6.0 REPORTING.....	13
7.0 QUALITY ASSURANCE/QUALITY CONTROL REQUIREMENTS	14
APPENDIX A FIELD DATA SHEETS	
APPENDIX B CALCULATION SHEETS	
APPENDIX C MODIFIED METHOD 5.1 ANALYTICAL PROCEDURE	
APPENDIX D VOC METHOD	
APPENDIX E TEST PROTOCOL FOR DETERMINING PARTICULATE AND VOLATILE ORGANIC COMPOUND EMISSIONS FROM CHAIN- DRIVEN CHARBROILERS	

RESTAURANT TESTING PROTOCOL

1.0 OVERVIEW AND APPLICABILITY

The South Coast Air Quality Management District (SCAQMD) has jurisdiction over the emissions of pollutants into the air from a variety of sources in Los Angeles County, Orange County, Riverside County and the non-desert portion of San Bernardino County. This area exceeds the national and state standards for PM10 and ozone. To address those and other pollutants, the SCAQMD developed a twenty-year Air Quality Management Plan (AQMP) to improve the air quality in the basin. Measure #PRC-03 of the 1997 AQMP proposes to reduce the emissions of particulate matter (PM) from restaurant operations. The control measure proposed to control emission from restaurant sources such as charbroilers (under-fired and chain-driven), deep-fat fryers, and indirect-fired grills (griddles). In addition, the June 1988 amendment to District Rule 219 requires that charbroiling equipment be permitted.

Charbroilers generate particulate matter emissions when the food being charbroiled secretes fluids which come into contact with the heating source. The fluids also vaporize or partially oxidize into volatile organic compounds that are emitted into the atmosphere. These emissions contribute to the production of suspended particulate matter and photochemical smog, both of which have demonstrated adverse health effects. Similar emissions are produced by a wide variety of cooking equipment.

This protocol has been developed to ensure standardization of compliance testing procedures. It is applicable to all restaurant appliances, with or without control devices, venting their emissions through any stack. Both "field" and "laboratory" type tests may be performed using this protocol. The section regarding product cooking rate (process weight) however, is oriented towards field testing, since the cooking rate at actual restaurants during high traffic periods often

cannot be precisely controlled. In addition, cooking rate for laboratory testing at standardized test kitchens are generally specified in separate cooking protocols.

This document is best used by referring to the specific section needed for a specific task. For example, the main sampling protocol gives general guidance for test procedures (section 4), calculations (section 5), reporting (section 6), and quality assurance/quality control (section 7). The test method for particulate matter is identified as SCAQMD Method 5.1 (see section 3 for complete reference) and the VOC test method is attached in Appendix D. These test methods have been applied to the following restaurant operations:

- 1) hamburger cooked on under-fired charbroiler
- 2) whole chicken cooked on under-fired charbroiler
- 3) Atlantic salmon fillet cooked on under-fired charbroiler
- 4) hamburger cooked on chain-driven charbroiler, with and without catalytic control device
- 5) breaded cod fillets cooked on flat griddle
- 6) hamburger cooked on griddle with shell down
- 7) hamburger cooked on griddle with shell up
- 8) chicken cooked on griddle with shell up
- 9) shoestring fries cooked in a deep-fat fryer
- 10) breaded chicken patties cooked in deep-fat fryer
- 11) breaded cod fillets cooked in deep-fat fryer
- 12) steak on an underfired charbroiler

The cooking pre-test and test procedures presented in this protocol only apply to hamburger cooked on a chain-driven charbroiler, with or without a catalytic oxidizer as a control device. For pre-test and testing procedures applicable to restaurant equipment and cooking configurations listed above, the reader is referred to the document "Further Development of Emission Test Methods and Development of Emission Factors for Various Commercial Cooking

Operations” Final Report for Applied Science and Technology Division, Contract No. 96027, July 24, 1997. It is SCAQMD staff’s intent to include the cooking pre-test and test procedures for the above listed restaurant cooking configurations not currently included in this document later. Additionally, any other restaurant operations that will be regulated in future rules will be included. The test methods for both particulate matter and VOCs are those referenced and included in this document.

2.0 DEFINITIONS

For the purposes of this test protocol, the following definitions apply:

HOURS OF OPERATION are those hours beginning from the time an appliance is started (gas/heat source turned on) until the appliance is secured (gas/heat source turned off).

PARTICULATE MATTER (PM) means any material, except uncombined water, which exists in a finely divided form as a liquid or solid at standard conditions.

PROCESS WEIGHT is the pre-cooking weight of all products cooked during the test period. If actual weight is not possible, it is acceptable to average seven units of each product type, given that each piece is of similar size, composition and weight. Process weight is listed in terms of each product in the product mix.

PRODUCT MIX is the listing of all product types cooked during the testing period.

RESTAURANT means any stationary commercial cooking establishment which prepares food for human consumption.

SOLID PARTICULATE MATTER means particulate matter which exists as a solid at standard conditions.

VOLATILE ORGANIC COMPOUNDS (VOC) is any volatile compound of carbon, excluding methane, carbon monoxide, carbon dioxide, carbonic acid, metallic carbides or carbonates, ammonium carbonate and exempt compounds. **EXEMPT COMPOUNDS** are listed in District Rule 102.

3.0 SAMPLING AND ANALYTICAL METHODS

3.1 Particulate Matter

Sample the exhaust isokinetically following District Method 5.1 (refer to *South Coast Air Quality Management District Source Test Manual*, Method 5.1, "Determination of Particulate Matter Emissions from Stationary Sources Using a Wet Impingement Train"). The minimum testing time of 72 minutes is recommended. Longer testing times may be required for cooking processes with very low emissions in order to obtain samples above the lower detection limits. Use a stainless steel or glass probe and nozzle and a District Method 5.1 train. An additional straight tube impinger (empty bubbler) shall be placed in the front of the train [See Figure 1]. Perform organic extraction and particulate matter analysis on the probe and nozzle, the filter and the impingers using a modified District Method 5.1. The change in analysis methods involves using methylene chloride as a wash in addition to water and is detailed in Appendix C. All stopcock grease must be completely removed from joints following proper Laboratory Procedure before recovering the samples with methylene chloride. (WARNING: methylene chloride produces dangerous fumes and appropriate safety measures should be taken during its use.) IMPORTANT: If the sample is not analyzed within 48 hours, it should be recovered and stored at 4°C until analysis can be completed. Analysis should be completed within two weeks.

3.2 Volatile Organic Compounds

The VOC test method is presented in Appendix D.

SOUTH COAST AIR QUALITY MANAGEMENT DISTRICT

Particulate Sampling Apparatus - Wet Impingement Method

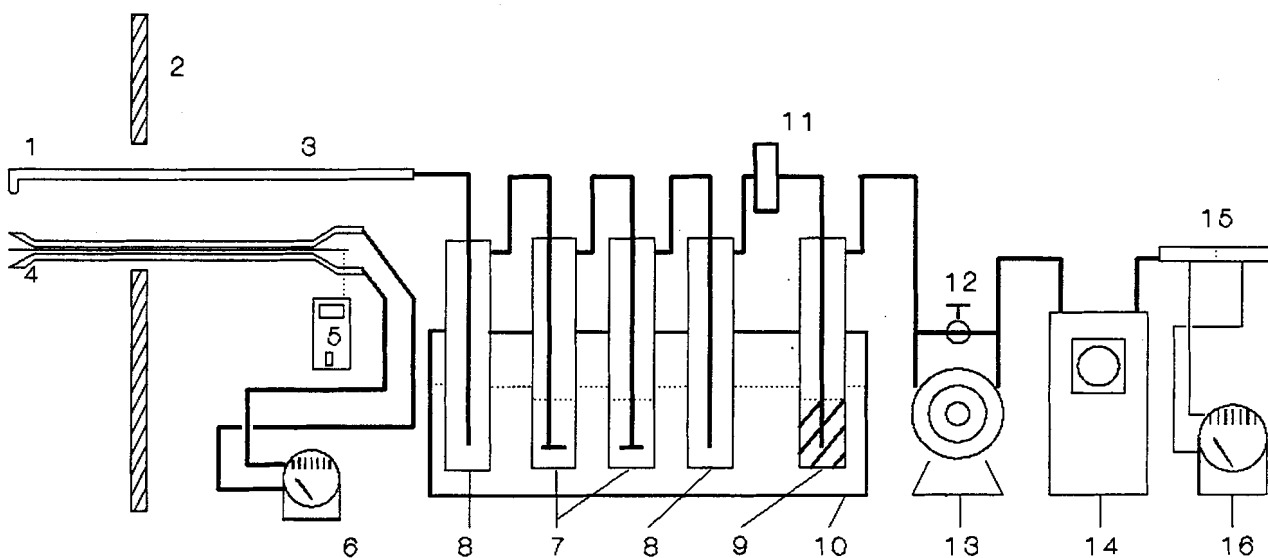

- | | |
|---|---|
| 1. Nozzle | 9. Bubbler with Tared Silica Gel |
| 2. Stack Wall | 10. Ice Bath |
| 3. Stainless Steel Probe | 11. Back-up Filter |
| 4. "S" Type Pitot Tube
and Type "K" Thermocouple | 12. By-pass Valve |
| 5. Digital Potentiometer | 13. Sealed Pump |
| 6. Pitot Tube Differential Pressure Gauge | 14. Temperature Compensated Dry Gas Meter |
| 7. Impingers with 100 ml De-ionized Water | 15. Orifice |
| 8. Empty Bubbler | 16. Orifice Differential Pressure Gauge |

Figure 1
Modified Method 5.1

3.3 Flow Rate & Process Weight

3.3.1 Stack Flow Rate Measurements

Measure the flow rate during the isokinetic, traversed particulate sampling as specified in Section 2.7 of District Method 5.1, dated March 1989 (refer to *South Coast Air Quality Management District Source Test Manual*). For calculating the stack velocity, use the average of the flow rates measured at each point sampled during the test.

3.3.2 Process Weight Measurements

The process weight is the weight of products that are cooked during the sampling time. Any food item cooked on any equipment vented to the outside through the exhaust stack must be counted and reported. Separate the product into food types, i.e. number of hamburgers, number of skinned chicken pieces, number of unskinned chicken pieces, etc. Specify the tally, grouping items if necessary, after testing is completed. Fat content from the supplier should also be noted when available. Also note other information that would demonstrate and identify the product being cooked, such as supplier, grade, etc. Measure an exact weight of each food type cooked, prior to cooking. It is acceptable to evaluate an average unit weight (average of at least 7 typical units), as long as every piece is of similar size, composition and weight. The standard deviation of the meat product weight should not exceed 6% of the average unit weight. To determine the process weight of each food type, multiply the number of units cooked by the average pre-determined weight per unit. The total process weight is the sum of all individual process weights.

If applicable, obtain and report a daily meat production rate in order to calculate a pounds of emissions per day value.

3.3.3 CO, CO₂, and O₂ Determination

These gases may be quantified using either District Method 10.1 or Method 100.1. For processes with high dilution, the oxygen content may be considered to be 20.9%.

4.0 TESTING PROCEDURES

4.1 Set-Up

Follow stack and port set-up in District Method 1.1 (refer to *SCAQMD Source Test Manual*).

Perform a cyclonic flow check, and document that cyclonic flow complies with District Method 1.1. Refer to Chapter X of the Source Test Manual for alternative procedures if cyclonic flow is present.

If either the ducting, cooking equipment or control device are new, condition the entire set-up before testing. To condition, allow normal cooking to occur for one week while all the equipment (including the control device) is in normal operation. Normal cleaning may occur during this conditioning time.

4.2 Pre-Test

Leak check the PM train according to District Method 5.1. Weigh the product to be cooked or determine the average weights per each food type in the product mix. If not already in use, allow the cooking device to warm-up according to the manufacturer's instructions.

4.3 Test

Conduct the particulate testing over a minimum period of 72 minutes and under the specified loading condition of the cooking equipment. In a restaurant setting, the normal lunch period (11 am to 2 pm) and the normal dinner period (6 pm to 9 pm) will be considered maximum loading conditions, unless a specific restaurant has special operating times or unusual peak hours.

Normal cleaning may occur during testing, but should be carefully noted and reported.

During the test, record the specific items that are being cooked, the quantity and the cooking devices involved. These records are to be kept for any cooking device in operation that is vented to the stack being tested.

Field data sheets to be used for the particulate and the VOC tests are included in Appendix A.

4.4 Post-Test

After the test, leak check the sampling train as done in the pre-test check. Tally the weight of all the food cooked during the sampling time using the methods described in Section 3.3 of this report. During field tests, obtain from restaurant manager the quantities and types of food cooked during the entire day.

5.0 CALCULATIONS

Carry out all calculations to at least one digit beyond that of acquired data, then round off after the final calculations to two significant digits. Round off all numbers according to ASTM E380-82 procedures. Use the calculation sheets in Appendix B.

5.1 Process Weight Calculations

Using the data acquired during testing, determine the process weights for individual product types. Include the weight of each item cooked, or show the weights of the units used to determine an average unit weight. Indicate the pounds per unit type cooked during the sampling period. Calculate the total pounds of product cooked per hour. Report the individual and total pounds cooked during the sample period, individual and total pounds cooked per hour and individual and total pounds cooked during the entire day.

5.2 Particulate Matter Calculations

Use the calculation sheets in Appendix B to determine pounds per hour emission rate of solid particulate matter (EE) and the particulate matter concentration in grains per dry standard cubic foot (BB). Isokinetic sampling rates must also be between 90% and 110% in order for the test to be valid.

Report the volume flow rate (dscfm), the total PM solid emission rates (lbs/hr) and the PM sample concentrations (gr/dscf).

5.3 Pounds per Day Calculations

Calculate the pounds per day value for both the particulate matter and the VOC using the following equation:

$$\begin{aligned} \text{Total Daily Emissions} &= \frac{\text{Hourly Emissions}}{\text{Total Hourly Process Wt}} \times \text{Total Daily Process Weight} \\ &= \frac{\text{PM (lb/hr)}}{\text{Product (lb/hr)}} \times \text{Product (lb/day)} \end{aligned}$$

Report PM emission rates in lbs/day.

5.4 Efficiency of the Control Device

Calculate the destruction efficiency for PM and VOCs using the following equation:

$$\text{Destruction Efficiency} = \frac{\text{Inlet Mass Emission Rate} - \text{Outlet Mass Emission Rate}}{\text{Inlet Mass Emission Rate}} \times 100\%$$

Generally simultaneous samples at the inlet and outlet of the control device are collected. For test conditions in which simultaneous inlet and outlet sampling is not possible, alternative sampling methods shall be submitted for AQMD approval.

6.0 REPORTING

A formal report shall be submitted in the format outlined in Chapter II of the *SCAQMD Source Test Manual*. If deviations occur between the manual and this protocol, follow this protocol.

All compliance certification reports shall include the following:

1. QA/QC procedures followed for all measuring equipment, including calibration test data.
2. QA/QC procedures followed for all sampling and analysis equipment, including calibration test data.
3. Chain of custody for samples.
4. Field notes and data sheets.
5. Calculations/averaging sheets/printouts.

7.0 QUALITY ASSURANCE/QUALITY CONTROL REQUIREMENTS

Follow the Quality Assurance/Quality Control guidelines outlined in the *SCAQMD Source Test Manual*, unless otherwise specified in this protocol. The following are examples of QA/QC requirements in the guidelines that pertain to restaurant operations:

1. Chain-of-Custody and calibration documents must be submitted for all restaurant testing.
2. Trip blanks of the Method 5.1 PM train should accompany the sampling apparatus and the Chain-of-Custody. These trains shall also be analyzed for quality assurance purposes.
3. The cooking equipment should be maintained according to manufacturer's instructions.

APPENDIX A FIELD DATA SHEETS

Use the following sheets (attached) when collecting field data.

Tests No. _____

SOUTH COAST AIR QUALITY MANAGEMENT DISTRICT

Date: _____

Sampling Location _____

Field Calculations Reference Sheet

Table 1-2
Location of Traverse Points in Circular Stacks
(Percent of stack diameter from inside wall to traverse point)

Traverse point number on a diameter	Number of traverse points on a diameter												Diameter
	2	4	6	8	10	12	14	16	18	20	22	24	
1	14.6	6.7	4.4	3.2	2.6	2.1	1.8	1.6	1.4	1.3	1.1	1.1	
2	35.4	25.0	14.6	10.5	8.2	6.7	5.7	4.9	4.4	3.9	3.5	3.2	
3		75.0	39.6	19.4	14.6	11.8	9.9	8.5	7.3	6.7	6.0	5.5	
4			93.3	70.4	32.3	22.6	17.7	14.6	12.5	1.4	1.3	1.1	1.1
5				85.4	61.7	34.2	25.0	20.1	16.9	14.6	12.9	11.6	10.5
6				95.6	89.6	65.8	35.6	26.9	22.0	18.8	16.5	14.6	13.2
7					89.5	77.4	64.4	36.6	28.3	23.6	20.4	18.0	16.1
8					96.8	85.4	75.0	63.4	37.5	29.6	25.0	21.8	19.4
9						91.8	82.3	73.1	62.5	38.2	30.6	26.2	23.0
10						97.4	88.2	79.9	71.7	61.8	38.8	31.5	27.2
11							93.3	85.4	78.0	70.4	61.2	39.3	32.3
12							97.9	90.1	83.1	76.4	69.4	60.7	39.8
13								94.3	87.5	81.2	75.0	68.5	60.2
14								98.4	91.5	85.4	79.6	73.8	67.7
15									95.1	89.1	83.5	78.2	72.8
16									98.4	92.5	87.1	82.0	77.0
17										95.6	90.3	85.4	80.6
18										98.6	93.3	88.4	83.9
19											96.1	91.3	86.8
20											98.7	94.0	89.5
21												96.5	92.1
22												98.9	94.5
23													96.8
24													98.9

Note:
First and last sample points cannot be closer than one inch from the edge of the stack.

% of H₂O at Saturation

Temp. °F	% H ₂ O	Temp. °F	% H ₂ O	Temp. °F	% H ₂ O
50	1.2	130	15.1	180	51.1
60	1.7	140	19.7	185	57.0
70	2.5	150	25.3	190	63.6
80	3.5	155	28.7	195	70.8
90	4.8	160	32.3	200	78.6
100	6.5	165	36.4	205	87.0
110	8.7	170	40.8	210	96.2
120	11.5	175	45.7	212	100.0

Duct Diameters Upstream from Flow Disturbance* (Distance A)

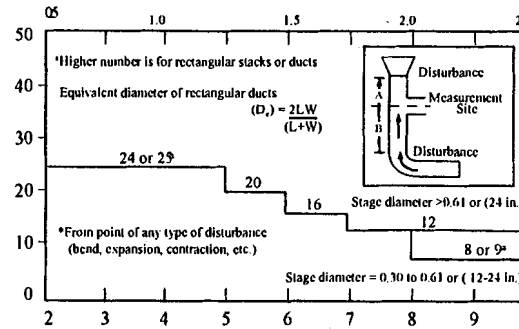

Duct Diameters Downstream from Flow Disturbance* (Distance B)

Nozzle Calibration

Date: _____

Calibrated by: _____

Nozzle Identification Number	D ₁ mm (in.)	D ₂ mm (in.)	D ₃ mm (in.)	ΔD mm (in.)	D _{avg}

Where:

D_{1,2,3} = nozzle diameter measured on a different diameter mm (in.). Tolerance - measure within 0.25 mm (0.001 in.)

Δ = maximum difference in any two measurements mm (in.). Tolerance = 0.1 mm (0.004 in.).

D_{avg} = average of D₁ D₂ D₃

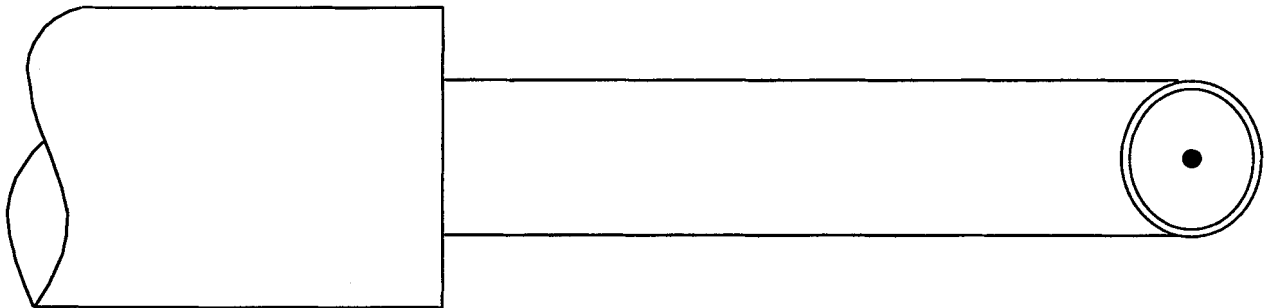

SOUTH COAST AIR QUALITY MANAGEMENT DISTRICT

Test No. _____

METER/PUMP SAMPLING SYSTEM CHECK

Pretest:

Date: _____

Time: _____

Meter # _____

Pump # _____

Orifice # _____

A-Orifice ΔH (in H ₂ O)	B - Metered Volume (ft ³)	C-Time (seconds)	K*
0.40			
0.75			
1.6			

Average _____

Performed by _____

Senior _____

Post Test:

Date _____

Time _____

A-Orifice ΔH (in H ₂ O)	B - Metered Volume (ft ³)	C-Time (seconds)	K*
0.40			
0.75			
1.6			

Average _____

Performed by _____

Senior _____

$$*K = \frac{60 \times B}{C \times \sqrt{A}}$$

*Maximum allowable difference in any two measurements of K is 0.02.

APPENDIX B CALCULATION SHEETS

Use the following sheets (attached) in performing calculations.

SOUTH COAST AIR QUALITY MANAGEMENT DISTRICT
 TECHNICAL SERVICES DIVISION

SOURCE TESTING AND MONITORING BRANCH

CALCULATION SHEET

PAGES	PAGE
TEST NO.	DATE
PROCESSED BY	CHECKED BY

METHOD 5.1

LAB ANALYSIS

- A. Probe Catch..... mg
- B. (1) Probe Acid..... mg
- (2) Probe Total Sulfate..... mg
- C. Impinger Catch..... mg
- D. (1) Impinger Acid..... mg
- (2) Impinger Total Sulfate..... mg
- E. Organic Extract..... mg
- F. Filter Catch..... mg
- G. (1) Filter Acid..... mg
- (2) Filter Total Sulfate..... mg
- H. H₂SO₄ . 2H₂O from SO_x Train Thimble..... mg
- I. Particulate Train Corrected Gas Volume Metered..... dscf
- J. SO_x Train Corrected Gas Volume Metered..... dscf
- K. Prorated H₂SO₄ . 2H₂O Mass ($\frac{H \times I}{J}$)..... mg
- L. Total Particulate (A-B* + C-D* +E +F-G* +K)..... mg
- M. Solid Particulate (L-E-K)..... mg

* USE LOWER OF (1) AND (2)

**SOUTH COAST AIR QUALITY MANAGEMENT DISTRICT
SOURCE TEST CALCULATIONS**

Test No. _____ Sampling Train: _____ Date: _____
 Calculated by: _____ Checked by: _____

Summary

- A. Average Traverse Velocity..... _____ fps
 B. Gas Meter Temperature (use 60°F, for Temp. Comp. Meters)..... °F
 C. Gas Meter Correction Factor..... _____
 D. Average Stack Temp..... °F J. Sampling Time..... min.
 E. Stack Cross-Sect. Area..... ft² K. Nozzle Cross-Sect. Area..... ft²
 F. Barometric Pressure..... "HgA L. Net Sample Collection..... mg
 G. Gas Meter Pressure..... "HgA M. Net Solid Collection..... mg
 H. Total Stack Pressure..... "HgA N. Water Vapor Condensed..... ml
 I. Pitot Correction Factor..... _____ O. Total Volume Sampled..... dcf

P. Corrected Gas Volume Metered [(O x G/29.92) x $\frac{520}{(460 + B)}$ x C]..... dscf

Percent Moisture/Gas Density

Q. Percent Water Vapor in Gas Sample [$\frac{4.64 \times N}{(0.0464 \times N) + P}$]..... %

R. Average Molecular Weight (Wet):

(Component)	(Volume %/100)	x (1 - Q/100)	x (Molec. Wt. =	(Wt./Mole))
Water		1.00	18.0	
Carbon Dioxide	Dry Basis		44.0	
Carbon Monoxide	Dry Basis		28.0	
Oxygen	Dry Basis		32.0	
Nitrogen/Inerts	Dry Basis		28.2	

Sum _____

Flow Rate

- S. Gas Density Correction Factor ($\sqrt{28.95 / R}$)..... _____
 T. Velocity Pressure Correction Factor ($\sqrt{29.92 / H}$)..... _____
 U. Corrected Velocity (A x I x S x T)..... fps
 V. Flow Rate (U x E x 60)..... cfm
 W. Flow Rate [$V \times \frac{H}{29.92} \times \frac{520}{(460 + D)}$]..... scfm
 AA. Flow Rate [W x (1 - Q/100)]..... dscfm

Sample Concentration/Emission Rate

- BB. Sample Concentration (0.01543 x L/P)..... gr/dscf
 CC. Sample Concentration (54,143 x BB/ _____ Molec. Wt.)..... ppm(dry)
 DD. Sample Emission Rate (0.00857 x AA x BB)..... lb/hr
 EE. Solid Emission Rate ($\frac{0.0001322 \times M \times AA}{P}$)..... lb/hr
 FF. Percent Isokinetic ($\frac{E \times P \times 100}{J \times K \times AA}$)..... _____

APPENDIX C MODIFIED METHOD 5.1 ANALYTICAL PROCEDURE

Attached is a flowchart detailing the recovery and analytical procedure for the analysis of the modified method 5.1 train used for charbroiler emissions sampling.

Charbroiler Recovery and Analytical Procedure Flowchart

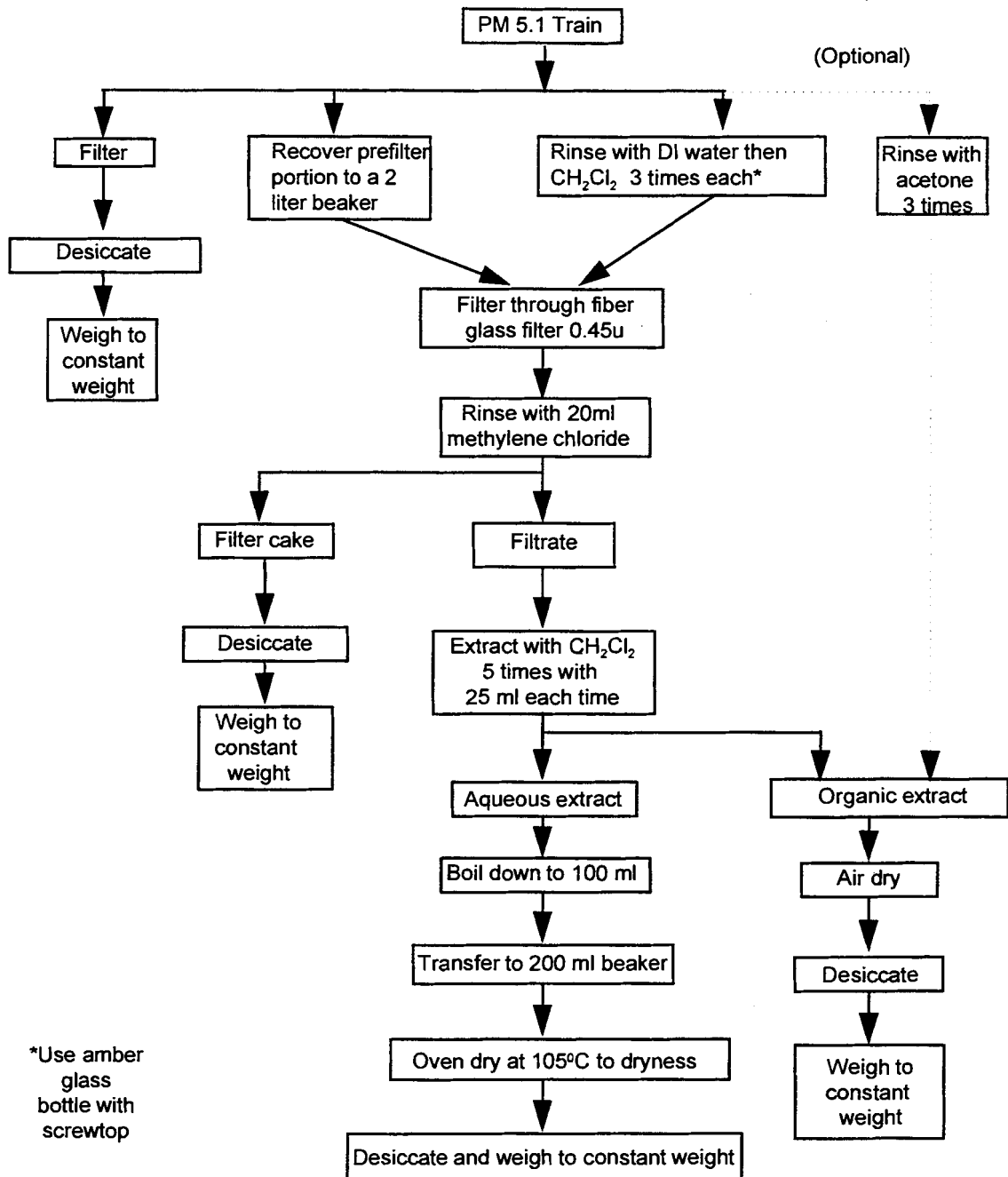

APPENDIX D VOC METHOD

**INSTRUMENTAL ANALYZER PROCEDURES FOR
VOLATILE ORGANIC COMPOUND (VOC) EMISSION SAMPLING
FROM COOKING EMISSIONS**

1.0 Overview

1.1 Principle

A representative sample of an exhaust gas stream is continuously extracted, conditioned, and conveyed to instrumental analyzers for the determination of VOC emissions from cooking processes. A sample conditioner removes liquid condensate from the sample stream, so that particulate matter may be condensed, and "double counting" of particulates with VOC may be avoided. A Flame Ionization Detector (FID) is used to continuously determine the VOC concentration in the sample gas stream. Simultaneous samples are also collected to determine the quantity of methane, aldehydes, and ketones. The final averaged VOC concentration is then corrected to subtract methane, and remove any response factor bias attributed to aldehydes and ketones.

Other systems may be used to measure VOC if they meet the specifications of this method and have been subjected to a relative accuracy test to determine equivalence.

Performance specifications and test procedures are provided to ensure reliable data. Typical analyzer specifications are shown in Table 1.

1.2 Applicability

This method measures emissions of VOC from cooking processes flowing in ducts. Repeatability of the method has been demonstrated for Standardized Test Kitchens¹. The method has yet to be field validated at commercial kitchens.

¹ 12 % coefficient of variation for a chain-driven charbroiler cooking hamburger patties. See "Further Development of Emission Test Methods and Development of Emission Factors for Various Commercial Cooking Operations," July 24, 1997.

2.0 Definitions

2.1 Measurement System

Equipment required to determine sample gas concentration consists of three major sub-systems:

Sample Interface - The portion of the system used for sample acquisition, sample transport, sample conditioning, and protection of the analyzers from the effects of the stack effluent.

Gas Analyzer - The portion of the system that identifies the gas component and generates an output proportional to its concentration.

Data Acquisition - An analog computer and printer for recording measurement data from the analyzer output.

2.2 Analyzer Calibration Error

The difference between the known concentration of the calibration gas and the gas concentration exhibited by the gas analyzer when the calibration gas is introduced directly to the analyzer.

2.3 Sampling System Bias

The difference between the gas concentrations exhibited by the measurement system when calibration gas is introduced at the sampling probe tip and when the same calibration gas is introduced directly to the analyzer.

2.4 Zero Drift

The difference in the measurement system responses at a zero concentration level during the initial calibration, and final calibration

check after a test. During this test there should be no unscheduled maintenance, repair, or adjustment of the measurement system.

2.5 Calibration Drift

The difference in the measurement system responses at a mid-range or high-range concentration level during the initial calibration, and final calibration check after a test. During this test there should be no unscheduled maintenance, repair, or adjustment of the measurement system.

2.6 Response Time

The time required for the system to display 95 percent of a step change in gas concentration on the data recorder.

2.7 Interference Response

The output response of the measurement system to a component in the sample gas, other than the gas component being measured.

2.8 Calibration Curve

A graph or other systematic method of establishing the relationship between the analyzer response and the actual calibration gas concentration introduced to the analyzer.

2.9 Linearity

Maximum deviation as a percent of range, between a mid-range calibration reading and the reading predicted by a straight line drawn between high-range and zero gas calibration points.

3.0 FID Analyzer Requirements

3.1 Measurement System Performance Specifications

VOC shall be measured and reported in units of parts per million (ppm) as CH₂.

3.1.1 Analyzer Calibration Error

Less than ± 3 percent of the high span gas concentration for the zero, mid-range, and high range calibration gases.

3.1.2 Sampling System Bias

Less than ± 5 percent of the span range for the zero, and the mid-range or high-range calibration gases.

3.1.3 Zero Drift

Less than ± 3 percent of the span range over the period of each run.

3.1.4 Calibration Drift

Less than ± 3 percent of the span range over the period of each run.

3.1.6 Linearity

Less than ± 3 percent of the span range.

3.2 Apparatus and Measurement System

A schematic of an acceptable measurement system is shown in Figure 1.

The essential components of the measurement system are described below.

3.2.1 Probe

Use quartz, borosilicate glass, or stainless steel tubing of approximately 1/4 inch diameter or larger. Use a heated probe if condensation occurs.

3.2.2 Sample Line

Use Teflon or stainless steel tubing to transport the sample gas to the moisture removal system. The sampling line should be heated to prevent condensation. It is not necessary to heat the sample transport line downstream of the moisture removal trap. A sample line made from another material may be used if the material does not absorb, adsorb, evolve, or alter the pollutants being monitored.

3.2.3 Sample Conditioning

- a. The sample conditioner shall reduce the sample temperature to 60°F and remove liquid condensate from the sample stream.
- b. All parts exposed to the sample should be glass, stainless steel, or Teflon.

3.2.4 Sample Transport Lines

Use Teflon or stainless steel lines to transport the sample from the moisture removal system to the sample pump, sample flow rate control, and sample gas manifold.

3.2.5 Impingers

The impingers shall be prepared and assembled similarly to the Rule 1138 protocol particulate train except for the final impinger. The silica gel containing impinger shall be excluded from the conditioning train.

3.2.6 Particulate Filter

A 0.45 micron glass fiber filter, without organic binder, shall be used. The filters shall comply with the requirements in Paragraph 2.2 of District Method 5.1 for a 0.45 micron filter. The filter should be fabricated of materials that are nonreactive to the gas being sampled.

3.2.7 Sample Pump

Use a leak-free pump to pull the sample gas through the system at a flow rate sufficient to minimize the response time of the measurement system. The pump may be constructed of any material that is nonreactive to the gas being sampled.

3.2.8 Sample Flow Rate Control

Use a control valve and rotameter to maintain a sampling rate constant within 10 percent.

The tester may elect to install a back pressure regulator to maintain the sample gas manifold at a constant pressure in order to protect the analyzers from over pressurization or the need for flow rate adjustments.

3.2.9 Sample Gas Manifold

Use a sample gas manifold to divert a portion of the sample gas stream to the analyzer, and the remainder to the aldehyde and ketone (DNPH)

sampling. The manifold may be constructed of any material that is nonreactive to the gas being sampled.

3.2.10 Data Recorder

Use an analog computer or digital recorder for recording measurement data. The data recorder resolution, or readability should be 0.5 percent of range. Sampling measurements should be obtained at a minimum of 5 second intervals.

3.2.11 Vacuum Gauge

Use a 30 in. Hg gauge for leak checking the sampling system.

3.2.12 FID Analyzer

An FID analyzer shall be used to measure uncorrected VOC emissions. A summary of typical specifications is shown in Table I (see Appendix).

3.3 Calibration Gases

Calibration gases shall be certified according to EPA Traceability Protocol Number 1. The calibration gas for VOC shall be methane. The balance gas shall be air, unless methane levels approach explosive limits.

3.3.1 High-Range Gas

The choice of the high range gas is dependent on the selection of the analytical range (see Paragraph 3.4.1) The high range gas concentration shall be between 80 to 100 ppm for VOC emissions less than 100 ppm, or shall be selected such that the VOC emission concentrations will be greater than 20% and less than 95% of the high span calibration gas value.

3.3.2 Mid-Range Gas

The concentration should be equivalent to 40 to 60 percent of the appropriate high range gas value.

3.3.3 Zero Air

The impurity concentration should be less than 0.25% of the full-scale range. Purified ambient air may be used for the zero gas by passing compressed air through a heatless dryer, a catalytic oxidizer, and a carbon dioxide scrubber.

3.4 FID Performance Test Procedures

Perform the following procedures before measurement of emissions.

3.4.1 Analytical Range

The analytical range is selected as follows for range settings of 100 ppm, 1000 ppm, and 10,000 ppm:

- a) For VOC concentrations less than, or equal to 100 ppm, the sample gas concentrations shall be measured using the 100 ppm range. Concentrations shall be between 20 and 100 percent of the range (or equivalently, between 20 ppm and 100 ppm), for 95 percent of the test period. The run is considered invalid if the measured gas concentration exceeds the range during the test period. Data obtained below 20 percent of the range can be used only for qualitative purpose;
- b) For VOC concentrations greater than 100 ppm, the sample concentrations shall be measured using the next highest analytical

range. A high span calibration gas shall be selected such that the emission concentrations will be greater than 20% and less than 95% of the high span calibration gas value. The run is considered invalid if the measured gas concentration exceeds the range during the test period. Data obtained below 20 percent of the range can be used only for qualitative purpose.

3.4.2 Sampling System Preparation

Allow the analyzer to warm up according to manufacturer's instructions. A leak check of the sampling system is a good practice. However, it is optional.

Assemble the sample train as shown in Figure 1. Leak check the vacuum side of the assembly to a minimum of 20 inches of Hg (gauge). The sampling system should hold 20 inches of Hg vacuum for 5 minutes with less than 1 in. Hg loss. Correct any leaks found and repeat the leak check until a satisfactory result is obtained. Check the pressure side of the system with liquid soap solution and correct any leaks. Alternative leak check methods are acceptable if equivalent or better than the specified method.

Introduce zero and high range calibration gases directly to the instrument and make all necessary adjustments to calibrate the analyzer and the data recording system. Adjust system components to achieve the analyzer sampling rate recommended by the instrument manufacturer.

3.4.3 Analyzer Calibration Error

Conduct the analyzer calibration error check at the beginning and end of each test run by introducing calibration gases to the measurement system at any point upstream of the gas analyzer as follows:

After the measurement system has been prepared for use, introduce the zero, mid-range, and high-range gases to the analyzer. During this check, make no adjustments to the system except those necessary to achieve the correct calibration gas flow rate at the analyzer. Record the analyzer responses to each calibration gas on a form similar to Figure 100.1-4 of District Method 100.1.

The calibration error check should be considered invalid if the gas concentration displayed by the analyzer exceeds ± 3 percent of the high span gas. If an invalid calibration is exhibited, take corrective action and repeat the analyzer calibration error check until acceptable performance is achieved.

3.4.5 Instrument Response Time

Establish instrument response time daily.

3.4.6 Sampling System Bias Check

A bias check of the sampling system is mandatory.

A zero gas and either the mid-range or high-range gas, whichever most closely approximates the effluent concentrations, should be used for this check as follows:

- a. Introduce the upscale calibration gas and record the gas concentration displayed by the analyzer on a form similar to Figure

100.1-5 of District Method 100.1. Introduce the zero gas and record the gas concentration displayed by the analyzer. During the sampling system bias check operate the system at the normal sampling rate and make no adjustments to the measurement system other than those necessary to achieve manufacturer recommended calibration gas flow rates at the analyzer.

- b. The sampling system bias check shall be considered invalid if the difference between the gas concentrations exhibited by the measurement system when a known concentration gas is introduced at the sampling probe tip and when the same gas is introduced directly to the analyzer, exceeds ± 5 percent of the analyzer range. If an invalid calibration is exhibited, take corrective action and repeat the sampling system bias check until acceptable performance is achieved.

If adjustment to the analyzer is required, first repeat the analyzer calibration error check, then repeat the sampling system bias check.

4.0 Aldehyde/ Ketone and Methane Sampling Requirements

4.1 Aldehyde/ Ketone Sampling Train

The DNPH Cartridge shall be prepared in accordance with the EPA Compendium Method T0-11 (Determination of Formaldehyde in Ambient Air Using Adsorbant Cartridge Followed by High Performance Liquid Chromatography, dated June 1988). The gas meter shall be calibrated per Chapter III of the District Source Test Manual. Connecting tubing shall comprise of materials unreactive to the sampling gases.

4.2 Methane Sampling System

Methane sampling may be performed using one of the following methods:

- a. methane shall be collected into an evacuated 9 liter nominal stainless steel canister (as specified in District Method 25.1). The gaseous sample shall be drawn into the canister at a constant rate. The condensate trap may be eliminated.
- b. The methane sample shall be pumped into a 10 liter (minimum) Tedlar Bag. All seams shall be heat-sealed.
- c. A second FID analyzer with an activated carbon filter may be used to continuously monitor methane.

5.0 Test Procedure

5.1 Set-up

The duct should be traversed to determine if there is stratification (see Chapter X of the District Source Test Manual). Determine moisture content and velocity pressures in the stack gas according to SCAQMD Methods 1.1, 2.1 and 4.1 if required for mass flow rate calculations. As an alternate method, the mass flow rate may be obtained by stoichiometric and gas composition relations. For processes with high dilution, the oxygen content may be considered to be 20.9%.

Assemble Aldehyde/ Ketone sampling train as shown in Figure 1 by placing the DNPH Cartridges in series. The tester shall determine the number of DNPH cartridges required to prevent break-through by performing a trial run. To date, experience has shown that three cartridges in series was adequate to prevent break-through.

A separate system shall be assembled for methane sampling.

The inlet probes shall be placed at the center of the duct.

5.2 Data Acquisition

Turn on the data acquisition system and label as to source, range, calibration cylinder ID number, certified expiration date, zero and upper range calibration settings, sample measurement rate, date, time, person operating instruments, and other pertinent data.

5.3 Sampling Time

A minimum sample time of 60 minutes is required. It is recommended however, that VOC sampling period be extended throughout the entire sampling period for particulate matter.

5.4 Zero and Calibration Drift Tests

Immediately preceding and following each run, or if adjustments are necessary for the measurement system during the run, repeat the sampling system bias check procedure. (Make no adjustments to the measurement system until after the drift checks are completed.) Record the analyzer's responses on a form similar to Figure 100.1-5 of District Method 100.1.

If either the zero or upscale calibration value exceeds the sampling system bias specification, then the run is considered invalid. Repeat both the analyzer calibration error check procedure and the sampling system bias check procedure before repeating the run.

Confirm that both the zero and upscale calibration values are within the sampling system bias specification. If the zero or upscale calibration drift value exceeds the drift limits, based on the difference between the sampling system bias check responses immediately before and after the run, repeat both the analyzer calibration error check procedure and the sampling system bias check procedure before conducting additional runs.

5.5 Sampling Rate

VOC sampling shall be at a rate to support the requirements of both the FID analyzer and the Aldehyde/ Ketone sampling systems. The Aldehyde/ Ketone sampling shall proceed at 1 cfm. The initial and final volumes of the Aldehyde/ Ketone gas meter shall be recorded. In addition, the gas meter temperature shall be recorded if the meter is not temperature compensated.

If methane is collected into a container, sampling shall be adjusted according to the volume of the stainless steel canister or Tedlar bag. If methane is measured continuously using an FID, the sampling rate shall be per manufacturer's instructions.

6.0 Aldehyde/ Ketone Determination

6.1 DNPH Analysis

The procedures in Compendium Method T0-11 (Determination of Formaldehyde in Ambient Air Using Adsorbant Cartridge Followed by High Performance Liquid Chromatography, dated May 1988) shall be followed to quantify aldehydes and ketones. Note that Section 14 of the Compendium Method discusses the detection of carbonyl containing compounds other than formaldehyde.

7.0 Calculations and Reporting

7.1 Emission Calculation

Determine the average VOC effluent concentration from the average gas concentration displayed by the gas analyzer. The average gas concentration displayed by the analyzer may be determined by averaging all of the effluent measurements. Sampling measurements should be obtained at a minimum of 5 second intervals. Calculate the effluent gas concentration by subtracting the methane concentration from the average VOC concentration, and adjusting for the aldehyde and ketone bias.

The unbiased aldehyde concentration is calculated by determining the biased parts per million concentration of aldehydes as CH₂, and dividing that number by 0.7425. Add the unbiased result to the VOC average, and subtract the biased aldehyde concentration.

The unbiased ketone concentration is calculated similarly. Use a correction factor of 0.49 for acetone, and 0.61 for 2-butanone.

Report the revised VOC concentrations in units of parts per million. The mass emission rate is calculated from the following relation:

$$\text{VOC Emission (lbs/hr)} = 1.583 \times 10^{-7} (\text{Exhaust Flow dscfm})(\text{VOC ppm})(14)$$

An emission factor in units of pounds of VOC per 1000 pounds of cooked product may be calculated by:

$$\frac{\text{lbs ROG}}{1000 \text{ lbs product}} = \frac{\text{ROG Emissions (lbs / hr)}}{\text{Product Cooking Rate (lbs / hr)}} \times 1000$$

Appendix
Tables and Figures

Table I
Typical Analyzer Specifications*

Analytical Method	Flame Ionization Detection
Measurement Ranges	0 - 100 ppm 0 - 1000 ppm 0 - 10,000 ppm
Sensitivity	1 ppm
Operating Temperatures	40 - 100 deg F.
Zero Drift	± 0.5% Full Scale
Fuel Consumption (H ₂)	30 cc/min
Combustion Air	300 cc/min
Sample Flow Rate	7 liters/min

* Specifications based on the Ratfish Instruments RS 55 oven heated analyzer

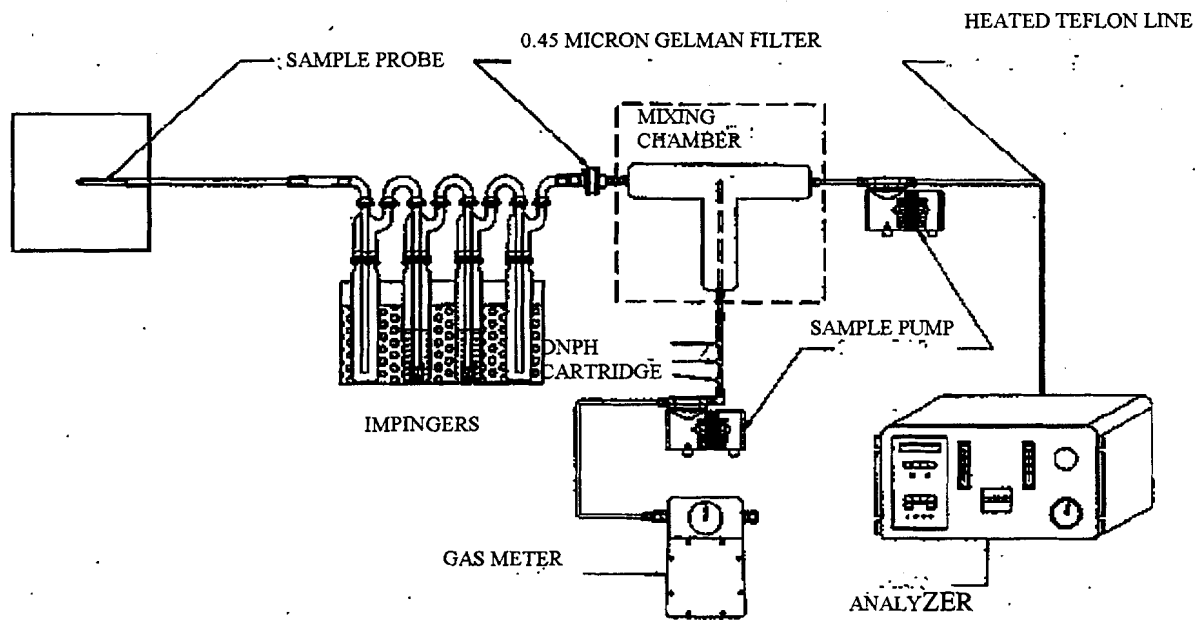

Figure 1

VOC Sampling System

APPENDIX E

SOUTH COAST AIR QUALITY MANAGEMENT DISTRICT

PROTOCOL

**TEST PROTOCOL FOR
DETERMINING PARTICULATE AND
VOLATILE ORGANIC COMPOUND EMISSIONS
FROM CHAIN-DRIVEN CHARBROILERS**

NOVEMBER 14, 1997

**SOURCE TESTING AND ENGINEERING BRANCH
APPLIED SCIENCE AND TECHNOLOGY**

TABLE OF CONTENTS

1.0	OVERVIEW AND APPLICABILITY	1
2.0	DEFINITIONS	2
2.1	CATALYTIC OXIDIZER	2
2.2	CHAIN-DRIVEN CHARBROILER	2
2.3	INDEPENDENT TESTING LABORATORY	2
2.4	MEAT	2
2.5	STANDARD CONDITIONS	2
3.0	TEST KITCHEN AND INSTRUMENTATION	3
3.1	TEST KITCHEN DETAILS	3
3.1.1	General Chamber Features	3
3.1.2	Natural Gas Supply	3
3.1.3	Hood and Duct System	3
3.1.4	Sampling Ports	4
3.1.5	Data Acquisition/ Recording System	4
3.2	INSTRUMENTATION	4
3.2.1	Calibrations	4
3.2.2	Pressure Measurements	4
3.2.3	Temperature Measurements	5
3.2.4	Barometric Pressure	5
3.2.5	Dry Gas Meter	5
3.2.6	Mass Measurements	5
3.2.7	Time Measurements	5
3.2.8	Calorimeter	6
4.0	ENVIRONMENTAL CRITERIA	7
4.1	Ambient Temperature	7
4.2	Relative Humidity	7
4.3	Barometric Pressure	7
4.4	Static Pressure	7
4.5	Background VOC Concentration	7

TABLE OF CONTENTS - Continued

5.0 PRE-TEST PREPARATIONS 8

 5.1 Test Kitchen 8

 5.1.1 Grease Baffles 8

 5.1.2 Ducting 8

 5.2 Charbroiler 8

 5.2.1 Positioning 8

 5.2.2 Firing Rate 8

 5.2.3 Broiler Controls 9

 5.2.4 Fuel Consumption 9

 5.2.5 Control Device 9

 5.2.6 Cleaning 9

 5.3 Meat 9

 5.3.1 Meat Specifications 9

 5.3.2 Storage 10

 5.4 Internal Meat Temperature 10

 5.4.1 Charbroiler Settings 10

 5.4.2 Patty Temperature Measurement 10

 5.4.3 Correlation Procedures 11

 5.4.4 Conveyor Speed 12

6.0 TEST PROCEDURE 13

 6.1 Test Runs 13

 6.2 Sampling Set-Up And Calibration 13

 6.2.1 Air Flow Rate 13

 6.2.2 Particulate Matter 13

 6.2.3 Gas Sampling 13

 6.3 Charbroiler Set-Up 14

 6.3.1 Warm-Up Period 14

 6.3.2 Power Input 14

 6.4 Test Procedure 14

TABLE OF CONTENTS - Continued

6.5 Post-Test Calibration And Analysis..... 15
6.5.1 Particulate Matter And Gaseous Emissions 15
6.5.2 Fat/ Moisture Content In Patties..... 15
6.5.3 Average Weight Loss 15
7.0 CALCULATIONS/ REPORTING 16

FIGURES

ATTACHMENT

1.0 OVERVIEW AND APPLICABILITY

The South Coast Air Quality Management District (AQMD) proposed Rule 1138 to fulfill requirements of Control Measure PRC-03 (Control of Emissions from Restaurant Operations) of the 1997 Air Quality Management Plan. This rule seeks to limit particulate matter (PM) and volatile organic compounds (VOC) from chain-driven charbroilers. Restaurants which cook greater than 875 pounds of meat per week will be required to install a control device which has been found to be as or more effective than a catalytic oxidizer (83%) in reducing both PM and VOC emissions.

This protocol has been developed to support Rule 1138 and to ensure standardization of compliance certification test procedures including the use of: specified test conditions, required test methods, specifications for test equipment, data collection/reporting, and quality assurance requirements.

An independent testing laboratory, approved by the South Coast Air Quality Management District, shall conduct the testing and prepare a report of findings, including all raw data sheets/charts and laboratory analytical data. This report and a request for product certification must be submitted to the Executive Officer. The testing must demonstrate to the satisfaction of the Executive Officer that emission reductions from the installation of a control on a chain driven charbroiler meets the requirements of Rule 1138 before product compliance certification is granted. Any control device for a chain-driven charbroiler must achieve greater than or equal to 83 percent reduction in both PM and VOC emissions.

When the cooking parameters do not fall within the testing guidelines of this protocol, the protocol may be modified following an equivalency determination and written approval of the Executive Officer.

2.0 DEFINITIONS

For purposes of this test protocol, the following definitions shall apply:

2.1 CATALYTIC OXIDIZER

A control device which burns or oxidizes smoke and gases from the cooking process to carbon dioxide and water, using an infrastructure coated with a noble metal.

2.2 CHAIN-DRIVEN CHARBROILER

A semi-enclosed cooking device with a mechanical chain which automatically moves food through the device and consists of three main components: a grill, a high temperature radiant surface, and a heat source.

2.3 INDEPENDENT TESTING LABORATORY

A testing laboratory that meets the requirements of South Coast Air Quality Management District's Rule 304, Paragraph (K), and is approved by the SCAQMD to conduct testing under this protocol.

2.4 MEAT

For purposes of Rule 1138, meat includes beef, lamb, pork, poultry, fish, and seafood.

2.5 STANDARD CONDITIONS

A gas temperature of 60°F and a gas pressure of 760 mm Hg (14.7 pounds per square inch) absolute.

3.0 TEST KITCHEN AND INSTRUMENTATION

3.1 TEST KITCHEN DETAILS

3.1.1 General Chamber Features

A test chamber equipped with natural gas, electricity, ventilation and fire suppression utilities shall be used to conduct the testing program. The dimensions of the chamber are 25 feet x 25 feet x 10 feet. Exhaust ventilation is provided by a hood that is ducted to a centrifugal-type upblast blower located on the roof of the chamber. Make-up air is supplied by an evaporative cooler and blower through four penetrations and eight diffuser panels in the test chamber ceiling. Access to the sampling locations shall be provided by a stairway outside of the chamber. A schematic of the chamber is shown in Figure 1.

3.1.2 Natural Gas Supply

Natural gas shall be provided by piping inside the chamber, and shall have a higher heating value of 1020 ± 25 Btu per standard cubic foot.

3.1.3 Hood and Duct System

Emissions generated during the cooking process shall be captured by a 4 feet x 4 feet Captive-Aire (or equivalent) stainless steel wall canopy hood. The bottom face of the hood shall be positioned 6 feet, 6 inches above the floor. Emissions captured by the hood are drawn horizontally through a 12 inch x 12 inch duct across the roof of the test chamber to the upblast blower. The exhaust blower, equipped with a variable speed drive and controller, shall be adjustable for precise setting of the exhaust flow rate. Emissions samples are drawn from the horizontal section of the duct through access ports.

3.1.4 Sampling Ports

The access ports shall be located 8 feet \pm 0.5 feet (8 duct diameters) downstream from a flow disturbance, and 2 feet \pm 0.5 feet (2 duct diameters) upstream of the VOC sampling ports. The VOC ports shall be located a minimum of 2 feet (2 duct diameters) upstream from a flow disturbance. The ducting configuration is shown in Figure 2.

3.1.5 Data Acquisition/ Recording System

A computer or digital recorder may be used for recording measurement data. Sampling measurements shall be capable of recording at a minimum of 5 second intervals.

3.2 INSTRUMENTATION

3.2.1 Calibrations

All instrumentation within this section and pertaining to this protocol shall be calibrated as a minimum within the requirements set forth in SCAQMD Source Test Methods Chapter III, Calibrations.

3.2.2 Pressure Measurements

Pressure measurement instruments shall have an error no greater than the following values:

<u>Measurement</u>	<u>Accuracy</u>	<u>Precision</u>
Gas Pressure	\pm 0.1" of water column	\pm 0.05" of water column
Atmospheric Pressure	\pm 0.1" of Hg column	\pm 0.05" of Hg column

3.2.3 Temperature Measurements

Temperature measuring instruments shall have an error no greater than the following values:

<u>Measurement</u>	<u>Accuracy</u>	<u>Precision</u>
Ambient Temperature	$\pm 0.5^{\circ} \text{ F}$	$\pm 0.25^{\circ} \text{ F}$
Meat Temperature	$\pm 0.2^{\circ} \text{ F}$	$\pm 0.1^{\circ} \text{ F}$

3.2.4 Barometric Pressure

Use a mercury, aneroid, or other barometer capable of measuring atmospheric pressure to within 0.1 in. Hg.

3.2.5 Dry Gas Meter

The quantity of fuel used by the charbroiler shall be measured in cubic feet with dry gas meter and associated readout device that is accurate within $\pm 1\%$ of the reading. The dry gas meter reading shall be corrected for gas pressure and temperature.

3.2.6 Mass Measurements

The weighing capacity of the scale shall be 6100 g, and be within a $\pm 0.3 \text{ g}$ reproducibility. Mass measurements shall also be accurate to within $\pm 1\%$ of measurement.

3.2.7 Time Measurements

The elapsed time measurement shall be measured with an instrument that is accurate within ± 0.5 seconds per hour.

3.2.8

Calorimeter

Heating value of the fuel must be measured. The repeatability of the measurement device shall be $\pm 1\%$ of full scale, and the precision of the device shall be ± 2 Btu/dscf. Calibration shall be conducted weekly using the device manufacturer's directions.

Alternately, heating value may be calculated based on gas speciation of the fuel. Refer to ASTM Method D 1945, "Standard Method for Analysis of Natural Gas by Gas Chromatography" and D 3588, "Standard Practice for Calculating Heat Value, Compressibility Factor, and Relative Density of Gaseous Fuels."

4.0 ENVIRONMENTAL CRITERIA

4.1 Ambient Temperature

Testing shall be conducted indoors with the ambient air temperature of the test room maintained between 65°F and 85°F at all times during the test. The ambient temperature shall be monitored and recorded before and after the test.

4.2 Relative Humidity

The relative humidity shall be between 20% and 65% during the test. It shall be recorded before and after the test.

4.3 Barometric Pressure

The barometric pressure shall be monitored and recorded before and after each test.

4.4 Static Pressure

The static pressure in the test chamber shall be recorded before and after each test.

4.5 Background VOC Concentration

Background VOC readings in the test duct shall be recorded prior to and following each test. These readings are for quality assurance purposes however, and shall not be used to subtract from VOC measurements recorded during the test.

5.0 PRE-TEST PREPARATIONS

5.1 Test Kitchen

5.1.1 Grease Baffles

The grease baffles shall be cleaned with detergent and water prior to testing. The baffles need not be cleaned within a set of test runs, unless the cooking operations are impaired by grease build-up.

5.1.2 Ducting

For test kitchens which have never performed certification testing, a cyclonic flow and stratification check is required. The absence of cyclonic flow shall be verified by Paragraph 2.4 of District Method 1.1; gas stratification shall be checked using the procedure in Chapter X, Section 13, in the District Source Test Manual.

5.2 Charbroiler

5.2.1 Positioning

The chain-driven charbroiler shall be positioned under the hood such that the perimeter of the hood overlaps the outer edge of the charbroiler on the front and sides by at least 6 inches. In addition, both sides of the appliance shall be a minimum of 3 feet from any side wall, side partition, or other operating appliance. The vertical distance between the hood and the top of the charbroiler shall be per manufacturer specifications. It is recommended that preliminary testing be conducted to visually confirm that particulates emitted from the charbroiler are captured by the hood.

5.2.2 Firing Rate

The firing rate shall be set to operate within 5% of the manufacturer's specified input rate. Additionally, the burners shall be adjusted to within 2.5% of the specified operating pressure.

5.2.3 Broiler Controls

The broiler controls, including the conveyor speed and the thermostat, shall be set according to the manufacturer's specifications.

5.2.4 Fuel Consumption

Install one or more instruments to measure the quantity of natural gas consumed in accordance with Section 3.2.5 of this protocol.

5.2.5 Control Device

The control device shall be installed such that the hood positioning requirements of Section 5.2.1 are satisfied. The vertical distance between the hood and control device shall be per manufacturer's specifications.

5.2.6 Cleaning

Prior to conducting a test set, the charbroiler unit shall be cleaned according to manufacturer's instructions.

5.3 Meat

5.3.1 Meat Specifications

The nominal specifications of the hamburger meat shall be quarter-pound, finished grind, pure beef patties, 21% fat by weight, 58-62% moisture, 3/8 inch thick, and 5 inches in diameter. The fat and moisture content shall be analyzed in accordance with recognized laboratory procedures (AOAC Official Actions 960.39 and 950.46, respectively). One patty per test run shall be randomly selected for these analyses. A set of three test runs, for example, would require three patties be reserved for fat and moisture content analyses.

Depending on the test objectives, alternative meat specifications such as meat type, fat content, etc. may be tested following written approval of the Executive Officer.

5.3.2 Storage

Sheet pans shall be loaded with 24 patties (6 patties per level by 4 levels), separating each level by a double sheet of waxed freezer paper. Store the patties in a freezer maintained at approximately -5°F. The pans shall be stacked with approximately 1/4 inch spacers between each pan to allow air flow. The freezer temperature shall be continuously monitored with a thermocouple placed in the freezer to ensure the pre-cooked condition of the meat.

5.4 Internal Meat Temperature

5.4.1 Charbroiler Settings

The charbroiler chain speed shall be adjusted to a targeted internal meat temperature of 165°F for hamburger patties. Other internal meat temperatures may be acceptable based on food type or cooking procedure, following written approval of the Executive Officer.

5.4.2 Patty Temperature Measurement

The internal meat temperature shall be determined with a stack of six to eight hamburger patties placed in a temperature measurement system. The system consists of an insulated container with a thermocouple bundle attached to the lid (see Figure 3). One thermocouple is located in the center, and the remaining four are arranged in a square pattern at a radial distance of 1 inch from the center. The dimensions tabulated below apply to Figure 3:

Item	Dimension
Outer Casing Diameter	8"
Inner Casing Diameter	4.75"
Center Thermocouple Length (Below Top Plug)	2.25"
Radial Thermocouple Lengths (Below Top Plug)	1.25", 1.5", 1.75", 2.5"
Depth of Inner Casing	6.5" *
Top Insulation Plug	1"
Bottom Plug Thickness	Varies **

* Includes the thicknesses of the top and bottom plugs

** Varies depending on the thickness of the hamburger patties. For 3/8 inch thick patties, the plug thickness was 2.25 inches.

Patties shall be inserted into the temperature measurement system immediately after removal from the charbroiler.

5.4.3 Correlation Procedures

Research conducted by Pacific Gas & Electric Company (PG&E Standard Test Method for the Performance of Underfired Broilers, 1995) has determined that the final internal temperature of cooked hamburger patties may be measured by the percent weight loss incurred during cooking. For hamburger patties specified in Section 5.3.1 of this protocol, an internal meat temperature of 165°F corresponds to a weight loss of approximately 32%.

Weight loss measurements are determined as follows: measure the weight of a full pan (24 patties) prior to cooking. Subtract the weight of the pan to determine the initial weight of the patties. Once the patties have traversed the charbroiler, use tongs to spread the patties on a drip rack. After one minute, the patties are turned.

After the second minute, transfer the patties to a clean, tared pan for weighing. Weight loss shall be determined on a full pan (24 patties) basis.

For meats other than the hamburger patties specified in Section 5.3.1, a correlation shall be developed using a minimum of three temperatures. These temperatures shall bracket the targeted meat temperature.

5.4.4 Conveyor Speed

Operate the charbroiler as described in Section 6 of this protocol. Patties shall be loaded two at a time at 30 second intervals. The internal meat temperature shall be verified by the correlation method in Section 5.4.3. Adjust the conveyor speed to achieve a 32% weight loss.

6.0 TEST PROCEDURE

6.1 Test Runs

A minimum of three test runs shall comprise a test set. One test set shall be conducted without a control device, another test set shall be conducted with the control device installed. It is recommended that a test set be conducted within a span of one week.

Note that the minimum required runs are assumed for chain-driven charbroilers cooking meat with the specifications in Section 5.3.1, using a catalytic oxidizer as the control. Additional test runs may be necessary for other meats or control devices based on the variability of the cooking process.

6.2 Sampling Set-Up And Calibration

6.2.1 Air Flow Rate

The velocity in the duct shall be set at 1600 fpm (with the charbroiler on). This velocity corresponds to a hood flow rate of 400 cfm for each linear foot of hood length.

6.2.2 Particulate Matter

The particulate matter sampling train and connecting equipment shall be prepared, calibrated, and checked in accordance with the protocol: "Determination of Particulate and Volatile Organic Compound Emissions From Restaurant Operations" (Sampling Protocol). Refer to the Sampling Protocol for Quality Assurance/ Quality Control Requirements.

6.2.3 Gas Sampling

The sampling systems and connecting equipment for VOC, oxygen, carbon monoxide, carbon dioxide, and methane measurement shall be prepared, calibrated,

and checked in accordance with the Sampling Protocol. Refer to the Sampling Protocol for Quality Assurance/ Quality Control Requirements.

6.3 Charbroiler Set-Up

6.3.1 Warm-Up Period

The charbroiler unit shall be operated for a minimum of one hour. VOC shall be monitored for background readings during the final 15 minutes of the warm-up period. As noted in Section 4.5, these readings are for quality assurance purposes, and shall not be used to subtract from VOC measurements recorded during the test.

6.3.2 Power Input

During the warm-up period, the flow meter shall be monitored to verify that the firing rate is within the requirements of Section 5.2.2 of this protocol.

6.4 Test Procedure

The conveyor speed shall be set to achieve the target weight loss, per Section 5.4.4 of this protocol. Prior to PM and VOC sampling, patties shall be loaded two at a time at 30 second intervals for at least 10 minutes.

Immediately following the 10 minute conditioning period, begin sampling for PM and VOC using the Sampling Protocol. The patties shall continue to be loaded two at a time at 30 second intervals. Sampling times shall be as follows:

Particulate Matter	72 minutes;
VOC	60 minutes; and,
CO, CO ₂ , O ₂ , methane	60 minutes.

The weight loss shall be verified every third tray using the procedures described in Section 5.4.3.

One cooked patty from each run shall be reserved for moisture analysis. If moisture analysis is not immediately conducted, place the cooked patties inside self-sealing plastic bags and store in a freezer maintained at -5°F.

6.5 Post-Test Calibration And Analysis

6.5.1 Particulate Matter And Gaseous Emissions

Post test calibration checks and leak checks shall be conducted in accordance with the Sampling Protocol. Follow procedures referenced in the Sampling Protocol to analyze for PM, the corrected concentration for VOC, carbon monoxide, carbon dioxide, oxygen, and methane.

6.5.2 Fat/Moisture Content In Patties

Fat and moisture content of the patties shall be analyzed according to procedures specified in Section 5.3.1 of this protocol. The fat content shall be determined for the uncooked patties only. Identify the cooked and uncooked samples so that moisture loss may be calculated.

6.5.3 Average Weight Loss

The average weight loss for the test run shall be $32\% \pm 5\%$. Repeat the test run if the average weight loss is outside this range.

7.0 CALCULATIONS/ REPORTING

PM and VOC calculations shall be in accordance with the Sampling Protocol, except the Pounds Per Day calculation, (Section 5.3 of the Sampling Protocol) shall be excluded.

Use weights of the uncooked meat for calculation and reporting purposes.

Report test results according to Section 6.0 of the Sampling Protocol. Destruction efficiency for the control device shall be calculated as follows:

$$\text{Destruction Efficiency} = \frac{\text{Without Control} - \text{With Control}}{\text{Without Control}} \times 100\%$$

where:

Without Control = Mass Emissions (lb/hr) from charbroiler without the control

With Control = Mass Emissions (lb/hr) from charbroiler with the control installed.

FIGURES

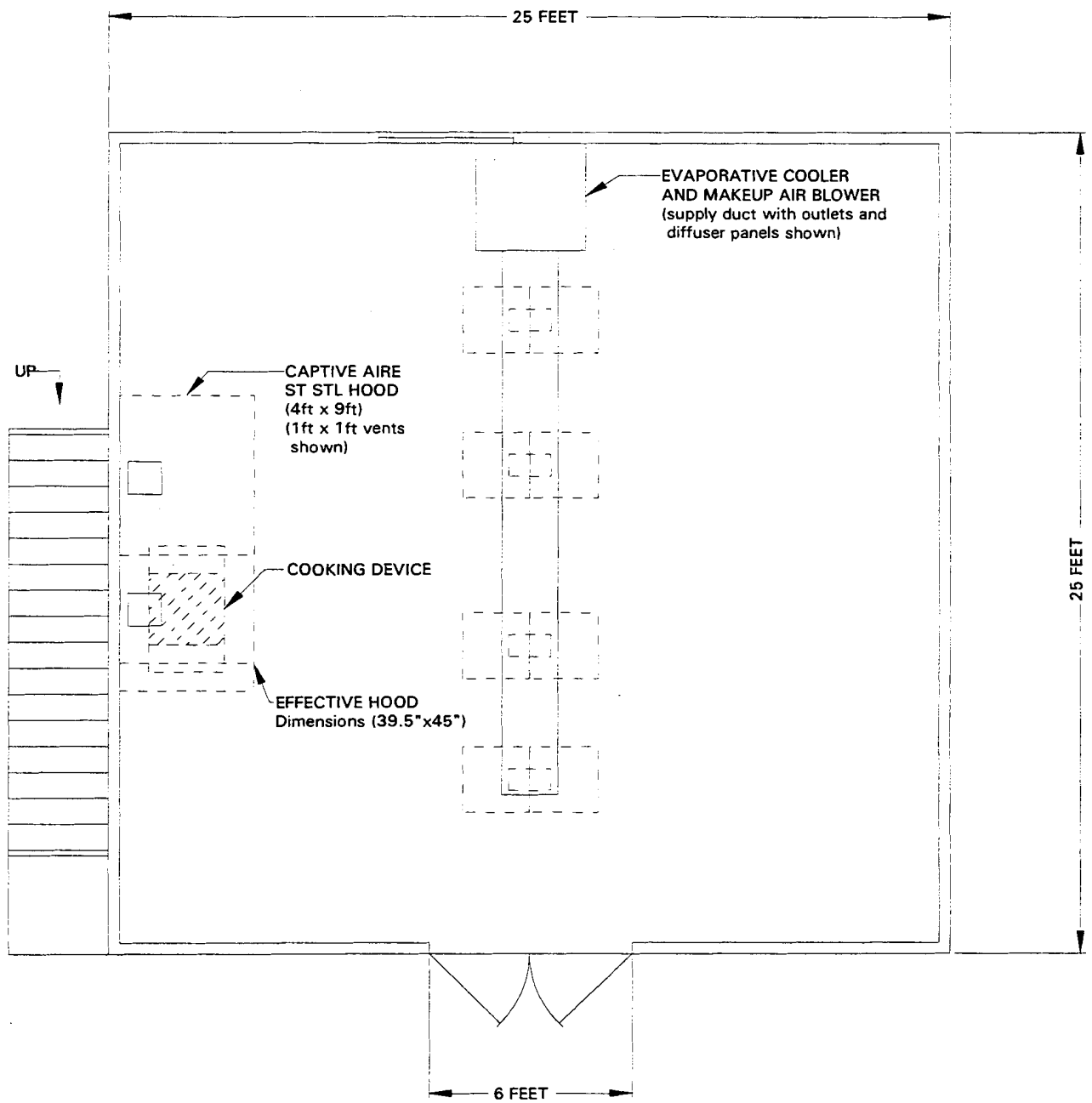

FIGURE 1
TEST KITCHEN DETAILS

CE-CERT
TEST KITCHEN FACILITY

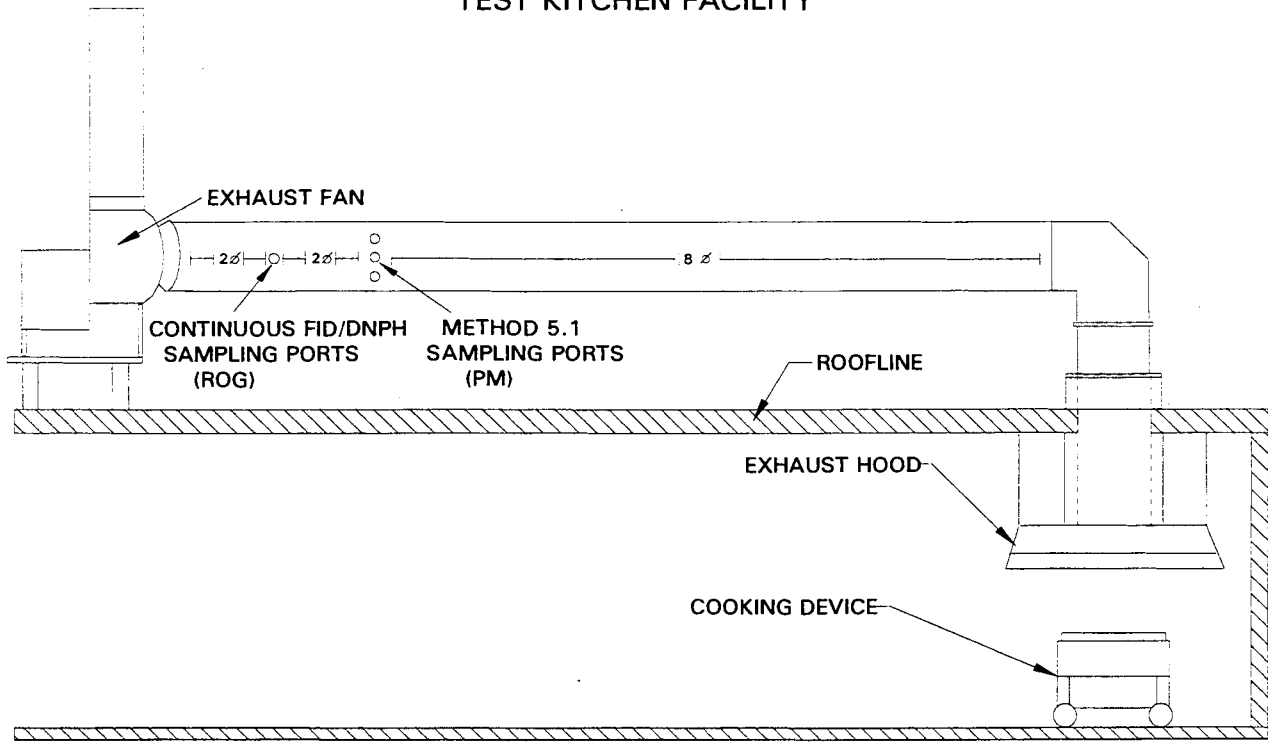

FIGURE 2
DUCT DETAILS

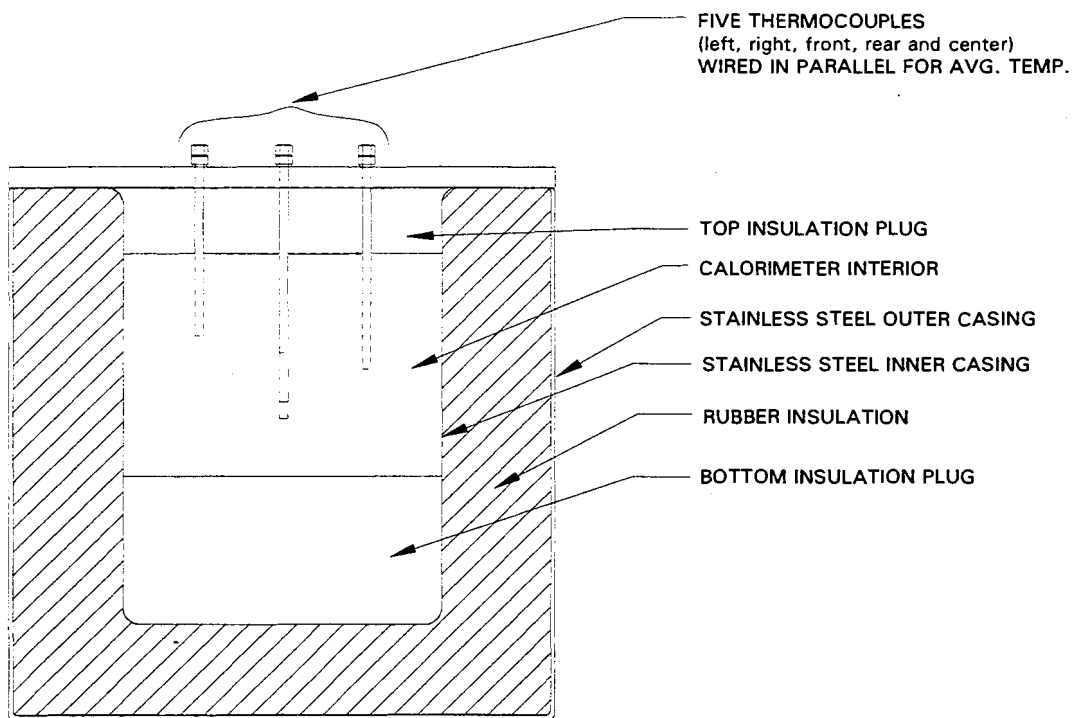

FIGURE 3
PATTY INTERNAL TEMPERATURE MEASUREMENT

APPENDIX C RESPONSES TO COMMENTS

Appendix C presents the responses to comments received during the public comment period from November 5 through November 26, 2007. During this period, the District received five comment letters from the following individuals:

- Derek Schrock, Research Director at Halton Company on November 7, 2007
- Robert Ajemian, President of Green Kitchen Designs on November 13, 2007
- Kevin Westlye, Executive Director of the Golden Gate Restaurant Association on November 13, 2007
- Dan Hopkins, President of Crest Distribution and Supply on November 19, 2007
- Sally Rump, California Air Resources Board on November 21, 2007

Derek Schrock, Research Director at Halton Company, November 7, 2007, via e-mail:

Comment: Mr. Schrock commented that the measurement technique being proposed for Regulation 6, Rule 2 requires a paper filter in the 1st half of US EPA Method 5 that does not differentiate the size of the particulates. US EPA Method 5 thereby captures the entire range of particulates emitted from the stack and not just the particulates from 0.3 to 10 microns to which the proposed regulation limits its definition of PM₁₀. To measure only particulates from 0.3 to 10 microns, Mr. Schrock suggested using a cascade impactor that uses several stages of paper filtration to limit the size of particulates captured on the filters.

Response: This comment was also raised during the public workshop held on October 23, 2007. Following the workshop, District staff changed the definition of PM₁₀ in the proposed rule, consistent with US EPA Method 5, to include all particulates less than 10 microns.

Robert Ajemian, President of Green Kitchen Designs, November 13, 2007, via e-mail:

Comment: Mr. Ajemian had two concerns regarding the proposed regulation. First, restaurant owners may by-pass the regulation by purchasing an under-fired charbroiler that is less than 10 square feet grill surface area. Secondly, the requirements for under-fired charbroilers do not minimize the emissions of air toxics and organic compounds that may be a greater health hazard than particulate matter less than 10 microns in diameter. Air toxics may be

significantly reduced by including adsorbant in the control device, at minimal additional costs.

Response: The 10 square foot grill provision in the proposed rule is an easily identifiable visual determination of the applicability of a restaurant to the rule requirements. This is important in order for the District to optimize utilization of its inspection resources when there are over 15,000 restaurants in the District. This rule targets the largest restaurants with the highest emissions by focusing on facilities with large grills and that grill significant quantities of beef.

The proposed rule does reduce air toxics emitted from under-fired charbroilers. In a 2003 study conducted by the National Cheng Kung University in Taiwan¹, researchers determined that particulates, not gases, emitted from restaurants had the highest carcinogenic potency. Large molecular weight polycyclic aromatic hydrocarbons (PAHs) known to be carcinogenic are exhausted in the particulate phase. The proposed rule would reduce the amount of particulates emitted to the atmosphere and thereby, minimize the amount of PAHs and the potential health hazard associated with under-fired charbroiling.

Staff investigated controls that reduce emissions of organic compounds and particulate matter from under-fired charbroilers, but determined that none that were cost-effective at this time. This proposed rule focuses on reducing harmful particulate matter through the use of cost-effective controls.

Kevin Westyle, Executive Director of Golden Gate Restaurant Association, November 13, 2007, via e-mail:

Comment: Mr. Westyle stated that he discussed the proposed rule at the November meeting of the Public Affairs Committee of the Board of Directors of the Golden Gate Restaurant Association. He stated, "The proposed rule for existing under fire char broilers seems reasonable. The 800# per week of beef grilled on the char broiler as the trigger mechanism of the requirement for new equipment to limit emissions was viewed as an effort to be reasonable.

The proposed rule for new equipment beginning in 2010 was hotly debated. At the conclusion of the discussion overall agreement was reached that a new restaurant would know in advance if the installed 10 square feet of under fire char broiler they would trigger the need for increased emission filtration. Serious concern exists for the carbon footprint of the catalytic oxidizer, and for the net gain for the environment.

¹ Li, Chun-The; Lin, Yuan-Chung; Lee, Wen-Jhy; and Tsai, Perng-Jy. 2003. *Emissions of Polycyclic Aromatic Hydrocarbons and Their Carcinogenic Potencies from Cooking Sources to the Urban Atmosphere*. Environmental Health Perspectives. Volume 111, Number 4, pp. 483-487. April 2003.

The proposed rule that in 2013 any existing restaurant with 10 square feet of under fire char broiler would need to install new equipment for increased emission filtration was not well received at all. People have designed their kitchen and invested their money under a certain set of rules, and feel changing the rules after the fact is unfair. We strongly encourage you to continue the 800# per week of beef guideline into 2013 and beyond.”

Response: The exemption for under-fired charbroilers grilling less than 800 pounds per week of beef does continue after 2013. The proposed rule would exempt any person who operates an under-fired charbroiler in a restaurant that grills less than 800 pounds of beef per week on the under-fired charbroiler. An analogous exemption exists for persons operating restaurants with chain-driven broilers. The exemptions apply regardless of when the proposed rule would otherwise require installation of an emission control device. Thus, the exemption the commenter refers to would not cease to apply in 2013.

Also, staff notes that all control devices that may be used to comply with the proposed rule will generate carbon either directly by converting organic compounds into carbon dioxide or indirectly through the use of electricity. Overall, however, most of the control devices require minimal electricity to operate. Catalytic oxidizers, required for chain-driven charbroilers, use no additional energy and benefit human health by converting a significant quantity of hazardous compounds into carbon dioxide and water.

Dan Hopkins, President of Crest Distribution and Supply, November 19, 2007, via e-mail:

Comment: We fully support the District’s direction to develop and enforce control of commercial under-fired charbroiler emissions. Areas of the proposal we would like to address are the following: Section 6-2-204 Demand Ventilation Controls: Use of Demand Ventilation Controls should be required in the rule. All restaurants currently operating can use these controls. They are readily available. Almost any electrical engineer is able to design a system using them and the IMC Building codes support their use. The amount of energy reduced and the associated cost is substantial. The return on investment is usually under 12 months. Reducing energy demand and costs is the only way the rule can provide a financial incentive for the owner to keep his equipment operational and continue to reduce emissions. If the rule is too expensive to follow, the operator will find a way around the rule. If reducing emissions is profitable then operators will be enthusiastic about doing it. Using Demand Ventilation Controls is the way to do this. Without the adoption of a Demand Ventilation Controls provision in the rule, successful emission control from this stationary pollution source will be difficult at best.

Response: District staff acknowledges the commenter’s support of this regulation. The purpose of the regulation is to minimize emissions of particulate

matter, which can be achieved by installing controls. Demand ventilation systems do not reduce particulate matter or organic compounds. Staff concurs that properly designed demand ventilation may reduce the volume of air needed for ventilation and would, in turn, reduce energy demand and lower energy bills. In the Bay Area, Pacific, Gas, and Electric (PG&E) offers not only rebates for energy efficient equipment, but also provides energy audits and demand/response programs for the food service industry.

Sally Rump, California Air Resources Board, November 21, 2007, letter sent via e-mail:

Comment: The Air Resources Board has reviewed Rule 6-2, and based on the information available to us at this time, we have no comments. The rule was examined by the Enforcement Division and by the Stationary Source Division.

Response: Comment is acknowledged.



APPENDIX D

REGULATION 6, RULE 2 COMMERCIAL COOKING EQUIPMENT

OCTOBER 2007

Prepared for
Bay Area Air Quality Management District

Prepared by
Applied Development Economics
100 Pringle Avenue, Suite 560 • Walnut Creek, California 94596 • (925) 934-8712
2151 River Plaza Drive, Suite 150 • Sacramento, CA 95833 • (916) 923-1562
www.adeusa.com

TABLE OF CONTENTS

1. Introduction and Summary.....	1
2. Description of Proposed Rule.....	3
3. Impact of Proposed New Rules: Regulation 6, Rule 2: Commercial Cooking Equipment ..	5
Appendix A: Estimating Number of Restaurants By Type	25
Appendix B: Economic Profile of Food Services Industries	26
Appendix C: Amount of Beef Prepared By Select National Chains	27
Appendix D: Aggregate Annual Amount of Prepared Beef.....	28
Appendix E: Revenue-Adjusted After-Tax Net Profit Trends	29
Appendix F: After-Tax Net Profit Trends	30
Appendix G: After-Tax Net Profit Trends: Select Restaurants	31

1. INTRODUCTION AND SUMMARY

The Bay Area Air Quality Management District (“District”) is proposing Regulation 6, Rule 2 to directly regulate emissions from restaurants. In proposing this regulation, the District focuses its efforts on reducing emissions from two types of restaurant equipment generally known as “charbroilers,” which produce over 80 percent of commercial cooking emissions. Proposed Regulation 6, Rule 2 would regulate “chain-driven charbroilers” and “under-fired charbroilers.”

As part of the rule-making process, the District investigated a variety of control options for addressing charbroiler emissions. The District reviewed reports conducted by universities, other air districts, and city-based health departments. As a result of its investigation, the District crafted Regulation 6, Rule 2 to require restaurants with chain-driven charbroilers to install what are called “catalytic oxidizers” to limit emissions of both PM and VOC or to install a certified alternative control, if restaurants purchase at least 500 pounds of beef per week and cook at least 400 lbs of beef per week on the charbroiler. Owners of restaurants with one or more under-fired charbroilers with a total grill surface area of at least 10 square feet that, at the same time, purchase at least 1,000 pounds of beef per week and cook at least 800 pounds of beef per week on the charbroiler will be required to install a control certified to reduce PM emissions. The District anticipates these proposed standards will result in 85 percent reduction in PM emitted by affected charbroilers and an 86 percent reduction in VOC emitted by chain-driven charbroilers.

SUMMARY

The report below shows that there are 13,348 restaurants in the nine-county Bay Area. At 6,228 and 6,484 respectively, the number of “full-service restaurants” and “limited-service eating places” (i.e. fast food restaurants) are roughly equal, with the balance of the eating establishment organized under the “special food services” group, which comprises of cafeterias and venues that prepare and distribute food on special occasions, such as

football stadiums.¹ At 10,192 out of 13,348, the bulk of restaurants in the Bay Area employ less than 20 people. Based on our analysis, particularly with respect to amount of prepared and cooked beef by businesses within various workforce size categories, the report shows that proposed new rule Regulation 6, Rule 2 does not affect restaurants employing less than 20 people, i.e. the bulk of restaurants in the nine-county Bay Area.

The proposed rule will impact fast food establishments and full service establishments, particularly steakhouses. The proposal has different thresholds for applicability based on the type of equipment in use in the restaurant. Chain-driven charbroilers predominately are found in fast food restaurants and under-fired charbroilers are found predominately in full service restaurants, including steakhouses. The analysis concludes that businesses affected by the proposal are *not* significantly impacted by the rule. Moreover, small businesses are *not* disproportionately impacted by the proposed new rule.

¹ Bay Area county health department permits estimate the number of licensed food service establishments at 14,838. 13,348 restaurants, and further categorizations of restaurants by type of food service, are from Dun and Bradstreet.

2. DESCRIPTION OF PROPOSED RULE

Broilers are the central appliance for most restaurant kitchens and are used to cook steak, hamburgers, fish, chicken, and seafood, as well as to brown food and reheat plated food. All broilers are comprised of a grated grill and a heat source, where food resting on the grated grill cooks as the food receives heat either directly from the heat source, or indirectly by way of a radiant surface.

Proposed Regulation 6, Rule 2 would regulate two types of charbroilers: chain-driven and under-fired. A chain-driven (conveyorized) charbroiler is a semi-enclosed broiler designed to move food mechanically on a grated grill through the device as the food cooks. Food cooks quickly because chain-driven charbroilers have burners located both above and below the grill. Chain-driven charbroilers are most common in fast food restaurants.

In an under-fired charbroiler, the heat source is positioned at or below the level of the grated grill. Designs of under-fired charbroilers vary widely. Some under-fired broilers use charcoal or wood for fuel, but usually, the broilers are fueled by gas or electricity. In gas under-fired charbroilers, a radiant surface, such as a bed of ceramic briquettes or a metal shield, placed above the burners diffuses heat from the burners. The heating elements of electric charbroilers are often interwoven with, or sheathed inside, the grill. Under-fired charbroilers are common in fine dining and casual restaurants.

To estimate the number of charbroilers used in Bay Area restaurants, the District consulted a 1997 SCAQMD report called “Staff Recommendations Regarding Controlling Emissions from Restaurant Operations,” which reports findings from a survey of the type of equipment used in restaurant cooking operations in Southern California. According to that report, 33 percent of restaurants operate under-fired charbroilers and 3.7 percent operate chain-driven broilers. The District verified these percentages by conducting its own independent survey of Bay Area restaurants, which also determined under-fired charbroiler grill sizes. Based on these percentages, the District estimates that approximately 4,897 Bay Area restaurants operate under-fired charbroilers and 554 operate chain-driven charbroilers. Of the 4,897 under-fired charbroilers, the District estimates that about

489, or 10 percent, have a grill size of ten square feet or greater. With regard to the amount of cooked beef, the District used several studies to estimate the amount of meat cooked on restaurant charbroilers and the associated emissions. The District presents estimates on the amount of meat cooked per year on an individual charbroiler in the Bay Area in its staff report of November 2007. It is estimated that 443 of the 554 chain-driven charbroilers will be subject to the proposed standards in Regulation 6, Rule 2 based on the amount of beef cooked and approximately 200 of the 489 under-fired charbroilers with large grills will be subject to the standards based on the amount of beef cooked.

3. IMPACT OF PROPOSED NEW REGULATION 6, RULE 2: COMMERCIAL COOKING EQUIPMENT

This section of the socioeconomic analysis describes demographic and economic trends in the San Francisco Bay Area (Bay Area) region. Following an overview of the methodology for the socioeconomic analysis, the first part of this section compares the Bay Area against California and does so to provide a context for understanding demographic and economic changes that have occurred within the Bay Area between 1995 and 2005. For the purposes of this report, the Bay Area region is defined as Alameda, Contra Costa, Marin, Napa, San Francisco, San Mateo, Santa Clara, Solano, and Sonoma Counties.

METHODOLOGY

The socioeconomic analysis of the proposed new rule concerning commercial cooking involves the use of information provided directly by BAAQMD, as well as secondary data used to describe the industries affected by the proposed rule amendments. Based on information provided by BAAQMD staff, ADE determined that the impacts would affect businesses in a narrow set of industries, particularly those in food preparation industries of NAICS 7221 (full-service restaurants), NAICS 7222 (limited-service eating places), and NAICS 7223 (special food services).² With this information ADE prepared an economic descriptions of affected industries and businesses, as well as to analyze data on the number of jobs, sales levels, the typical profit ratios and other economic indicators for the Bay Area businesses. Data for particular types of restaurants that will be affected by the proposed rule more so than others was not readily available from the California Economic Development Department (EDD-LMID), the US Economic Census or US Bureau of Labor Statistics' County Business Patterns. Thus, to determine the number of beef-oriented restaurants such as steakhouses and hamburger restaurants, ADE combined data from EDD-LMID and the County Business Patterns with data from Dun and Bradstreet (see Appendix A).

² NAICS = North American Industrial Classification System

In addition to estimating the number of establishments by specific restaurant types and their respective employment figures, ADE estimated revenues, net profits and profit ratios using data from the US Economic Census and other sources such as US IRS and corporate annual reports. The result of the socioeconomic analysis shows what proportion of profit the compliance costs represent. Based on a given threshold of significance, ADE discusses in the report whether the affected establishments and industries are likely to reduce jobs as a means of recouping the cost of compliance. To the extent that such job losses appear likely and significant, the indirect multiplier effects of the job losses area estimated using a regional IMPLAN input-output model.

It is worth noting that this approach and the District staff approach to estimate that number of restaurants affected by the rule compare favorably considering the differences in approach.

REGIONAL DEMOGRAPHIC TRENDS

The Bay Area experienced moderate population growth from 1996 to 2006. Between 1996 and 2001, the nine-county region increased by nearly 1.4 percent annually, from 6.4 million in 1996 to almost 6.9 million in 2001. From 2001 to 2006, the population again shifted, this time from 6.9 million to 7.1 million for an increase of approximately 1.1 percent per year. California grew at a faster rate between 1996 and 2001 and 2001 and 2006, growing by 1.5 percent per year and 1.6 percent per year respectively. Within the Bay Area, the greatest percentage increase occurred in Contra Costa County. From 1996 to 2006 Contra Costa increased its population by 1.6 percent per year – the only area to grow at an annual faster than California’s growth rate over the same period. Table 1 shows the population changes that occurred in the Bay Area and California from 1996 to 2006.

[This space is blank]

TABLE 1
Population Trends: Nine-County San Francisco Bay Area Region, 1996 - 2006

	Population			Percent Annual Change		
	1996	2001	2006	96-01	01-06	96-06
California	31,962,949	34,441,561	37,195,240	1.5%	1.6%	1.5%
Bay Area	6,406,763	6,872,313	7,135,505	1.4%	0.8%	1.1%
Alameda County	1,345,787	1,465,753	1,509,981	1.7%	0.6%	1.2%
Contra Costa County	883,351	966,845	1,030,732	1.8%	1.3%	1.6%
Marin County	237,880	248,994	253,818	0.9%	0.4%	0.7%
Napa County	118,209	126,093	134,326	1.3%	1.3%	1.3%
San Francisco County	744,072	784,031	800,099	1.1%	0.4%	0.7%
San Mateo County	679,929	712,527	726,336	0.9%	0.4%	0.7%
Santa Clara County	1,599,332	1,701,665	1,780,449	1.2%	0.9%	1.1%
Solano County	368,534	401,662	421,542	1.7%	1.0%	1.4%
Sonoma County	429,669	464,743	478,222	1.6%	0.6%	1.1%

Source: Applied Development Economics, based on household population estimates from The California Department of Finance

REGIONAL ECONOMIC TRENDS

The Bay Area is one of the world's greatest regional economies. It benefits from pre-eminent knowledge-based industries, with competitive strength flowing from an unmatched culture of entrepreneurship, world-leading research institutions, and some of the nation's best educated and most highly skilled workforce. With these remarkable advantages, it has led through innovation in a wide range of research and industrial fields. As a sign of its strength and dynamism, if the nine-county San Francisco Bay Area region was its own country, its economy would rank in the top 15 of the world.

Table 2 below identifies some general trends in the Bay Area's economy between 1996 and 2006. As of 2006, the professional and business services sector was the largest employer in the region, at 554,576 jobs or 17 percent of all private and public sector jobs.³ This is a slight change from 1996 when professional and business services accounted for 16.5 percent of all Bay Area jobs. Between 1996 and 2006, professional and business services increased a slight 0.8 percent per year, a rate slower than growth

³ Table 2 shows "Trade, Transportation and Utilities" as employing 561,357 workers in 2006, or 17 percent of all workers in the Bay Area. We do not identify this broad sector as the "largest employer" in the Bay Area because "Trade, Transportation and Utilities" contains a widely varied set of industries, from retail, to transportation-warehousing, utilities, and wholesale.

exhibited by Information, Financial Activities, Educational and Health, and Leisure and Hospitality. As Table 2 shows, these sectors grew annually by 1.5 percent, 1.0 percent, 2.4 percent, and 1.6 percent respectively between 1996 and 2006. However, it is worth noting that both Financial Activities and Professional-Business Services exhibited reductions in workforce in the last five years between 2001 and 2006, as Table 2 shows. Another important part of the regional economy is the public sector, which altogether employs 442,048 workers, or 13.5 percent of all workers in the nine-county Bay Area. Yet, employment in these segments of the economy declined for the most part between 1996 and 2001 and 2001 and 2006. Table 2 shows Bay Area industry sectors and their trends from 1996 to 2006.

TABLE 2
Economic Profile of the Nine-County San Francisco Bay Area Region, 1996-2006

Industry	----- Employment Trends -----			Regional Employment Distribution, 2006	-- Annual Percent Change --		
	1996	2001	2006		96-01	01-06	96-06
Total Private-Public Sectors	3,077,910	3,180,139	3,275,433	100.00%	0.7%	0.6%	0.6%
Private Sector:							
Goods-Producing	612,552	682,136	567,697		2.2%	-3.6%	-0.8%
Natural Resources and Mining	26,861	29,517	22,760	0.69%	1.9%	-5.1%	-1.6%
Construction	128,937	192,338	192,897	5.89%	8.3%	0.1%	4.1%
Manufacturing	456,754	460,281	352,040	10.75%	0.2%	-5.2%	-2.6%
Service-Providing	2,041,790	2,358,456	2,265,688		2.9%	-0.8%	1.0%
Trade, Transportation, and Utilities	563,672	608,241	561,357	17.14%	1.5%	-1.6%	0.0%
Information	96,876	147,581	112,820	3.44%	8.8%	-5.2%	1.5%
Financial Activities	194,069	208,854	213,378	6.51%	1.5%	0.4%	1.0%
Professional and Business Services	509,591	619,989	554,576	16.93%	4.0%	-2.2%	0.8%
Education and Health Services	285,917	337,874	360,678	11.01%	3.4%	1.3%	2.4%
Leisure and Hospitality	273,778	304,944	320,772	9.79%	2.2%	1.0%	1.6%
Other Services	117,887	130,973	142,107	4.34%	2.1%	1.6%	1.9%
Government Ownership:							
Federal Government	83,162	57,652	53,001	1.62%	-7.1%	-1.7%	-4.4%
State Government	108,771	81,895	87,874	2.68%	-5.5%	1.4%	-2.1%
Local Government	231,635	298,251	301,173	9.19%	5.2%	0.2%	2.7%

Source: Applied Development Economics from data supplied by the Labor Market Information Division of the California Employment Development Department

DESCRIPTION OF AFFECTED INDUSTRIES

As Table 3 below indicates, there are 13,348 restaurants in the nine-county Bay Area. At 6,228 and 6,484 respectively, the number of “full-service restaurants” and “limited-service eating places” (i.e. fast food restaurants) are roughly equal, with the balance of the eating establishment organized under the “special food services” group. Table 3 also identifies the number of eating-places among various types of restaurant establishments that could be affected by the proposed new rule compared to other types of eating establishments, such as full-service “steakhouses” (146 establishments) or fast-food hamburger operations (667 establishments).⁴

⁴The number of fast-food hamburger restaurants and or full-service steakhouses is largely a function of the proportion of these restaurants in the Dun and Bradstreet dataset (see Appendix A). These proportions were applied against the gross number “full-service restaurants,” “limited-service eating places” or “special food services,” as reported by the EDD LMID. Based on the DnB proportions, the consultant initially estimated 241 fast-food hamburger establishments. At 241, the number of hamburger fast-foods amounts to 1.8 percent of all restaurants. In its corporate annual report, McDonalds indicates that this corporation alone represents 2.5 percent of all restaurants in the US. In addition, McDonald’s is 42 percent of the fast-food hamburger market in the United States. With these two metrics, we can adjust the number of fast-food hamburger restaurants in the nine-county Bay Area from 241 to 667. As it is, a cursory review of readily-available sources such as Yahoo® Yellow Pages for fast-food restaurants shows that there are 205 Burger King® and Carls’ Jr. ® restaurants in the region. Combining these restaurants with the number of McDonalds in the nine-county region suggests that the 667 estimate is reasonable.

TABLE 3
Economic Profile of Food Serving Industries Potentially Subject to Rule, 2006

NAICS	Industry Descriptions	Number of Establishments By Employment Size								
		Total Establishments	Total Employment	1-19	20-49	50-99	100-249	250-499	500-999	1000 or more
7221	Full-Service Restaurants	6,228	114,215	4,624	1,030	440	132	2	0	0
	<i>Steakhouse restaurants</i>	146	2,672	108	24	10	3	0	0	0
	<i>Other beef full-service rest.</i>	3,294	60,407	2,446	545	233	70	1	0	0
	<i>Others primarily poultry- fish</i>	209	3,829	155	35	15	4	0	0	0
	<i>All others</i>	2,580	47,306	1,915	427	182	55	1	0	0
7222	Limited-Service Eating Places	6,484	90,853	5,030	1,308	131	12	2	1	0
	<i>Fastfood hamburger estab</i>	667	3,374	518	135	13	1	0	0	0
	<i>Other fastfood establishments</i>	615	14,592	477	124	12	2	0	0	0
	<i>All other limited service</i>	5,202	72,887	4,035	1,050	105	9	2	1	0
7223	Special Food Services	636	11,994	538	62	18	14	1	3	1
		13,348	217,062	10,192	2,400	589	158	5	4	1

Source: Applied Development Economics, based on US BLS County Business Patterns (distribution of establishments by size), California EDD (number of establishments) and Dun and Bradstreet (establishments by type of restaurants [see Appendix A for detail]). Also: see Appendix B for estimated number of workers by employment size categories.

Table 3 also distributes the establishments by size in terms of number of workers per establishment. This information is important because it allows us to estimate the amount of beef that is prepared by restaurants using a pounds of beef per worker average we reached via a variety of other sources (see Appendix C). As Table 3 shows, at 10,192 out of 13,348, the bulk of restaurants employ less than 20 people.⁵ Proposed new rule Regulation 6, Rule 2 does not affect any of these small-sized restaurants, as we show later in this report.

Table 4 below identifies the amount of beef prepared on a weekly basis by the average restaurant in a variety of size categories. The table also identifies in which categories the average restaurant produces an amount of beef that exceeds either the 500- or the 1000-pound thresholds employed in Regulation 6, Rule 2 (see numbers in bold print in Table 4). For example, the average full-service steakhouse that employs between 20 and 49 people purchases and cooks 711 pounds of beef per week (or almost 100 pounds of beef per day). The average steakhouse that employs between 50 and 99 workers purchases and cooks an estimated 1,527 pounds of beef per week. Likewise, the average “other full-service restaurant” that employs between 100 and 249 people and prepares fish, poultry and other main courses along with beef purchases, on average, 1,430 pounds of beef per week. As Table 4 shows, the average fast-food hamburger operation that employs 20 to 49 workers prepares 779 pounds of beef per week, while the hamburger operation employing between 50 and 99 workers prepares 1,672 pounds per week. Based on this analysis of the average restaurants within a certain size in terms of employment, in all likelihood fast-food hamburger restaurants with at least 20 – 49 employees will be subject to provisions of Regulation 6, Rule 2, whereas full-service steakhouse restaurants will not be subject to the rule unless they employ at least 50 – 99 people.⁶

⁵ It is worth noting that typical fast-food eating establishments such as McDonalds and Burger King employ between 25 and 50 workers on average.

⁶ Based on limited data obtained from the District’s survey of area restaurants, District staff estimate that the average amount of beef cooked per week in a Burger King restaurant is 555 pounds and the average for a Carl’s Jr. restaurant is 767 pounds. Staff also calculated the weekly pounds of beef cooked from a high-volume Carls Jr. and found that they cook an estimated average of 1094 pounds per week. These two restaurant chains both use chain-driven charbroilers to cook hamburgers (for more information, see Appendix C).

TABLE 4
Average Weekly Amount of Beef Prepared By Restaurants By Size of Workforce, 2006

---- Average Weekly Pounds of Beef Prepared By Typical Establishment By Size ----										
NAICS	Industry Descriptions	Total Establishments	Total Employment	1-19	20-49	50-99	100-249	250-499	500-999	1000 or more
7221	Full-Service Restaurants	6,228	114,215	61	210	451	1,055	1,917	0	0
	<i>Steakhouse restaurants</i>	146	2,672	206	711	1,527	3,576	0	0	0
	<i>Other beef full-service rest.</i>	3,294	60,407	82	284	611	1,430	3,080	0	0
	<i>Others primarily poultry- fish</i>	209	3,829	52	178	382	894	0	0	0
	<i>All others</i>	2,580	47,306	26	89	191	447	754	0	0
7222	Limited-Service Eating Places	6,484	90,853	124	429	922	2,160	3,372	6,748	12,655
	<i>Fastfood hamburger estab</i>	667	3,374	226	779	1,672	4,965	0	0	0
	<i>Other fastfood establishments</i>	615	14,592	113	389	836	1,142	0	0	0
	<i>All other limited service</i>	5,202	72,887	113	389	836	2,148	3,192	6,388	0
7223	Special Food Services	636	11,994	127	436	938	2,196	3,028	5,400	12,655
		13,348	217,062	202	1,076	2,310	5,411	8,316	12,148	12,655

Source: Applied Development Economics, based on US BLS County Business Patterns (distribution of establishments by size), California EDD (number of establishments) and Dun and Bradstreet (establishments by type of restaurants [see Appendix A for detail]). Also: see Appendix B for estimated number of workers by employment size categories.

ANNUAL COST OF COMPLIANCE: REGULATION 6, RULE 2: COMMERCIAL COOKING EQUIPMENT

Table 5 identifies the various equipment impacted sources can utilize to control their respective emissions. In addition, the table identifies the total annual cost for each equipment. District staff believes that, in all likelihood, impacted sources with “chain-driven charbroilers” will employ a “catalytic oxidizer” to meet the requirements of the proposed new rule. Restaurants with “under-fire charbroilers” will choose either “HEPA filters” or “electrostatic precipitators.” The annual costs of these solutions are compared against estimated revenues and net profits for purposes of analyzing the socioeconomic impacts of Regulation 6, Rule 2.

TABLE 5
Annual Compliance Cost: Proposed Regulation
6, Rule 2: Commercial Cooking Equipment

Chain-driven Charbroiler	Tot. Annual Cost
Catalytic Oxidizer	\$2,028
Wet Scrubber	\$5,838
Electrostatic Precipitators	\$6,734
Fiber Bed Filters	\$11,405
Thermal Incinerator	\$100,111
Under-Fired Charbroilers	
HEPA Filters	\$8,254
Electrostatic Precipitators	\$8,799
Wet Scrubber	\$11,796
Thermal Incinerator	\$100,111

Source: Bay Area Air Quality Management District

It is worth noting that the District reports that 33 percent and almost four percent of all restaurants in the Bay Area employ either “under-fired charbroilers” or “chain-driven broilers,” respectively. However, for purposes of analyzing impacts, this report analyzes only the estimated number of restaurants that will purchase at least 500 pounds of beef per week and cook at least 400 pounds of beef a week on a chain-driven charbroiler, and those with a charbroiler grill surface area that is at least 10 square feet that purchase at least 1000 pounds of beef per week and cook at least 800 pounds per week on an under-fired charbroiler. In addition, this report assumes that chain-driven charbroilers are used in fast food restaurants, subject to the proposed rule at 500

pounds of beef purchased, and that under-fired charbroilers are used in full service restaurants, subject to the proposed rule at 1000 pounds of beef purchased. For example, Table 4 above indicates that, on average, the typical full-service steakhouse restaurant employing between 50 and 99 workers prepares 1,527 pounds of beef per week. Table 3 indicates that there are 10 full-service steakhouse restaurants in the Bay Area employing between 50 and 99 workers. Thus, the analysis assumes that all 10 restaurants will comply with the provisions of Regulation 6, Rule 2 in one of two ways, namely by utilizing either a HEPA filter or an electrostatic precipitator.

Tables 6 and 7 below report findings with respect to revenues and net profits. For the most part, revenues are based on gross and per-worker figures culled from the 2002 Economic Census for the Bay Area, which was then adjusted for inflation. Steakhouse restaurant revenues are based on revenues calculated using data in Appendix C. Revenue and net profit estimates are included only for categories whose respective average purchases exceeds the 500- and 1000-pound thresholds (as indicated in Table 4). Net profits are based on ratios found in Appendix E.⁷

⁷The US IRS issues financial data and ratios including net profits for businesses in certain revenue categories. As a result, analysts are able to distinguish after tax net-profit rates for low-revenue producing businesses from middle- to above-average revenue producing businesses. In issuing its revenue-adjusted data, the US IRS combines “restaurants” with “accommodations,” which includes hotels, motels and other lodgings. For the five-year period between 1999 and 2004, “restaurants and accommodations” after-tax net profit rate was 2.15 percent. Using another US IRS data set that does not adjust for revenue, we arrive at a 3.96 percent net profit rate for “restaurants” between 1999-2004, leading us to conclude that accommodations is dragging down the revenue-adjusted “restaurants and accommodations” net profit rate. We correct for this downward influence in Appendices E and F, and, where appropriate, apply these restaurant-only revenue-adjusted profit rates against Table 6 to obtain Table 7 net profits.

Table 6
Estimated Aggregate Revenue of Industries Subject to Proposed Regulation 6, Rule 2: Commercial Cooking Equipment

NAICS	Industry Descriptions	Establishments	Estimate of the Number of Establishments Subject to Rule Based on Amount of Beef Purchased and Cooked	Revenue Ranges						
				1-19	20-49	50-99	100-249	250-499	500-999	1000 or more
7221	Full-Service	6,228	114			\$23,136,061	\$589,091,373	\$17,689,603		
	Steakhouse	146	37	--- na ---	--- na ---	\$23,136,061	\$16,233,994	--- na ---	--- na ---	--- na ---
	Other beef rest.	3,294	71	--- na ---	--- na ---	--- na ---	\$572,857,378	\$17,689,603	--- na ---	--- na ---
	Oth poultry- fish	209	4	--- na ---	--- na ---	--- na ---	--- na ---	--- na ---	--- na ---	--- na ---
	All others	2,580	1	--- na ---	--- na ---	--- na ---	--- na ---	--- na ---	--- na ---	--- na ---
7222	Limited-Service	6,484	277		\$234,948,852	\$489,260,712	\$107,955,250	\$28,595,500	\$28,614,589	
	Hamburger	667	149	--- na ---	\$234,948,852	\$50,389,982	\$11,118,536	--- na ---	--- na ---	--- na ---
	Other fastfood	615	14	--- na ---	--- na ---	\$46,360,271	\$10,229,382	--- na ---	--- na ---	--- na ---
	All others	5,202	114	--- na ---	--- na ---	\$392,510,459	\$86,607,332	\$28,595,500	\$28,614,589	--- na ---
7223	Special Food Svs	636		--- na ---	--- na ---	--- na ---	--- na ---	--- na ---	--- na ---	--- na ---
		13,348	391		\$234,948,852	\$512,396,772	\$697,046,623	\$46,285,103	\$28,614,589	

Table 7
Estimated Aggregate After-Tax Net Profits of Industries Subject to Proposed Regulation 6, Rule 2: Commercial Cooking Equipment

NAICS	Industry Descriptions	Establishments	Number of Establishments Potentially Subject to Rule	Revenue Ranges						
				1-19	20-49	50-99	100-249	250-499	500-999	1000 or more
7221	Full-Service Restaurants	6,228	114		\$1,193,040	\$1,094,820	\$29,271,307	\$606,048		
	<i>Steakhouse restaurants</i>	146	37	--- na ---	\$1,193,040	\$1,094,820	\$806,649	--- na ---	--- na ---	--- na ---
	<i>Other beef-serving full-service restaurants</i>	3,294	71	--- na ---	--- na ---	--- na ---	\$28,464,657	\$606,048	--- na ---	--- na ---
	<i>Others that primarily serve poultry or fish</i>	209	4	--- na ---	--- na ---	--- na ---	--- na ---	--- na ---	--- na ---	--- na ---
	<i>All others</i>	2,580	1	--- na ---	--- na ---	--- na ---	--- na ---	--- na ---	--- na ---	--- na ---
7222	Limited-Service Eating Places	6,484	277		\$15,306,482	\$29,491,507	\$5,192,633	\$979,685	\$980,339	
	<i>Fastfood hamburger establishments</i>	667	149	--- na ---	\$15,306,482	\$1,726,366	\$380,922	--- na ---	--- na ---	--- na ---
	<i>Other fastfood establishments</i>	615	14	--- na ---	--- na ---	\$2,193,812	\$508,287	--- na ---	--- na ---	--- na ---
	<i>All other limited service</i>	5,202	114	--- na ---	--- na ---	\$25,571,329	\$4,303,424	\$979,685	\$980,339	--- na ---
7223	Special Food Services	636	0	--- na ---	--- na ---	--- na ---	--- na ---	--- na ---	--- na ---	--- na ---
		13,348	391		\$16,499,522	\$30,586,327	\$34,463,939	\$1,585,733	\$980,339	

Source: Applied Development Economics, based on US BLS County Business Patterns (distribution of establishments by size), California EDD (number of establishments), Dun and Bradstreet (establishments by type of restaurants), US Economic Census 2002 (revenue estimates) and US IRS (1999-2004 net profit rates for "food and accommodations" adjusted by revenue amounts [see Appendices E and F]).

The tables below present aggregate costs for those fast food restaurants that are in categories for which the average restaurant purchases more than 500 pounds of beef per week, and for those full service restaurants that are in categories for which the average restaurant purchases more than 1000 pounds of beef per week. The fast food restaurants will employ a chain-driven charbroiler. As an example, the “fast food hamburger” restaurants that employ between 20 and 49 purchase, on average, 779 pounds of beef per week. These 135 restaurants will annually bear costs of \$273,780 to comply with the rule using a catalytic oxidizer. In total, the other limited-service restaurants that employ at least 50 people that would be expected to be subject to the rule and use a catalytic oxidizer to comply with the rule will annually bear costs of \$294,060.

There are 10 steakhouses that employ 50 to 99 workers that, on average, purchase 1,597 pounds of beef per week. These restaurants will annually bear costs of \$82,540 if using a “HEPA filter” and \$87,990 if using an “electrostatic precipitator.” Large restaurants in the “other beef-serving full-service restaurants” category employing between 100 and 249 workers will annually bear \$577,780 in “HEPA filter” costs (see Table 9), or \$615,930 in “electrostatic precipitator” costs, depending on which emissions-control solution is right for these 70 businesses. Restaurants in the “All others” category among full-service restaurants may or may not have to comply with the rule, depending on the size of charbroiler and the amount of beef cooked. Based on this analysis, if all “Steakhouse restaurants,” “Other beef-serving full-service restaurants” and “Special food services” establishments that employ at least 100 people were subject to the rule based on a large under-fired charbroiler and amount of beef cooked, these 92 establishments in total would bear annual costs of \$759,368 to comply using a “HEPA filter” and \$809,508 to comply using an “electrostatic precipitator.”

Table 8
Estimated Aggregate Annual Costs of Industries Subject to Proposed Regulation 6, Rule 2: Commercial Cooking Equipment: Catalytic Oxidizer

NAICS	Industry Descriptions	Establishments	Est. Nos. of Establishments Subject to Rule Based on Beef Cooked	1000 or more						
				1-19	20-49	50-99	100-249	250-499	500-999	1000 or more
7221	Full-Service Restaurants	6,228	114							
	<i>Steakhouse restaurants</i>	146	37	--- na ---	--- na ---	--- na ---	--- na ---	--- na ---	--- na ---	--- na ---
	<i>Other beef-serving full-service restaurants</i>	3,294	71	--- na ---	--- na ---	--- na ---	--- na ---	--- na ---	--- na ---	--- na ---
	<i>Others that primarily serve poultry or fish</i>	209	4	--- na ---	--- na ---	--- na ---	--- na ---	--- na ---	--- na ---	--- na ---
	<i>All others</i>	2,580	1	--- na ---	--- na ---	--- na ---	--- na ---	--- na ---	--- na ---	--- na ---
7222	Limited-Service Eating Places	6,484	277		\$273,780	\$264,949	\$24,336	\$4,056	\$2,028	
	<i>Fastfood hamburger establishments</i>	667	149	--- na ---	\$273,780	\$27,288	\$2,028	--- na ---	--- na ---	--- na ---
	<i>Other fastfood establishments</i>	615	14	--- na ---	--- na ---	\$25,105	\$4,056	--- na ---	--- na ---	--- na ---
	<i>All other limited service</i>	5,202	114	--- na ---	--- na ---	\$212,556	\$18,252	\$4,056	\$2,028	--- na ---
7223	Special Food Services	636	0	--- na ---	--- na ---	--- na ---	--- na ---	--- na ---	--- na ---	--- na ---
		13,348	391		\$273,780	\$264,949	\$24,336	\$4,056	\$2,028	\$0

Source: Applied Development Economics, based on US BLS County Business Patterns (distribution of establishments by size), California EDD (number of establishments), Dun and Bradstreet (establishments by type of restaurants), US Economic Census 2002 (revenue estimates) and US IRS (1999-2004 net profit rates for "food and accommodations" adjusted by revenue amounts [see Appendices E and F]).

Table 9
Estimated Aggregate Annual Costs of Industries Subject to Proposed Regulation 6, Rule 2: Commercial Cooking Equipment: HEPA Filters

NAICS	Industry Descriptions	Establishments	Est. Nos. of Establishments Subject to Rule Based on Beef Cooked	1000 or more						
				1-19	20-49	50-99	100-249	250-499	500-999	1000 or more
7221	Full-Service Restaurants	6,228	114			\$82,254	\$601,021	\$8,254		
	<i>Steakhouse restaurants</i>	146	37	--- na ---	--- na ---	\$82,254	\$25,463	--- na ---	--- na ---	--- na ---
	<i>Other beef-serving full-service restaurants</i>	3,294	71	--- na ---	--- na ---	--- na ---	\$575,558	\$8,254	--- na ---	--- na ---
	<i>Others that primarily serve poultry or fish</i>	209	4	--- na ---	--- na ---	--- na ---	--- na ---	--- na ---	--- na ---	--- na ---
	<i>All others</i>	2,580	1	--- na ---	--- na ---	--- na ---	--- na ---	--- na ---	--- na ---	--- na ---
7222	Limited-Service Eating Places	6,484	277							
	<i>Fastfood hamburger establishments</i>	667	149	--- na ---	--- na ---	--- na ---	--- na ---	--- na ---	--- na ---	--- na ---
	<i>Other fastfood establishments</i>	615	14	--- na ---	--- na ---	--- na ---	--- na ---	--- na ---	--- na ---	--- na ---
	<i>All other limited service</i>	5,202	114	--- na ---	--- na ---	--- na ---	--- na ---	--- na ---	--- na ---	--- na ---
7223	Special Food Services	636	0	--- na ---	--- na ---	--- na ---	--- na ---	--- na ---	--- na ---	--- na ---
		13,348	391			\$82,254	\$601,021	\$8,254		

Source: Applied Development Economics, based on US BLS County Business Patterns (distribution of establishments by size), California EDD (number of establishments), Dun and Bradstreet (establishments by type of restaurants), US Economic Census 2002 (revenue estimates) and US IRS.

Table 10

Estimated Aggregate Annual Costs of Industries Subject to Proposed Regulation 6, Rule 2: Commercial Cooking Equipment: Electrostatic Precipitators

NAICS	Industry Descriptions	Establishments	Est. Nos. of Establishments Subject to Rule Based on Beef Cooked	1000 or more						
				1-19	20-49	50-99	100-249	250-499	500-999	1000 or more
7221	Full-Service Restaurants	6,228	114			\$87,990	\$640,706	\$8,799		
	<i>Steakhouse restaurants</i>	146	37	--- na ---	--- na ---	\$87,990	\$27,144	--- na ---	--- na ---	--- na ---
	<i>Other beef-serving full-service restaurants</i>	3,294	71	--- na ---	--- na ---	--- na ---	\$613,562	\$8,799	--- na ---	--- na ---
	<i>Others that primarily serve poultry or fish</i>	209	4	--- na ---	--- na ---	--- na ---	--- na ---	--- na ---	--- na ---	--- na ---
	<i>All others</i>	2,580	1	--- na ---	--- na ---	--- na ---	--- na ---	--- na ---	--- na ---	--- na ---
7222	Limited-Service Eating Places	6,484	277							
	<i>Fastfood hamburger establishments</i>	667	149	--- na ---	--- na ---	--- na ---	--- na ---	--- na ---	--- na ---	--- na ---
	<i>Other fastfood establishments</i>	615	14	--- na ---	--- na ---	--- na ---	--- na ---	--- na ---	--- na ---	--- na ---
	<i>All other limited service</i>	5,202	114	--- na ---	--- na ---	--- na ---	--- na ---	--- na ---	--- na ---	--- na ---
7223	Special Food Services	636	0	--- na ---	--- na ---	--- na ---	--- na ---	--- na ---	--- na ---	--- na ---
		13,348	391			\$87,990	\$640,706	\$8,799		

Source: Applied Development Economics, based on US BLS County Business Patterns (distribution of establishments by size), California EDD (number of establishments), Dun and Bradstreet (establishments by type of restaurants), US Economic Census 2002 (revenue estimates) and US IRS (1999-2004 net profit rates for "food and accommodations" adjusted by revenue amounts [see Appendices E and F]).

Tables 11 through 13 below express costs identified in the previous three tables as a percent of net profits. For most industries and business that are expected to bear costs, annual costs as a percent of net profits are below the ten-percent threshold used to determine if costs are significant. As Table 11 shows, annual cost of the “catalytic oxidizer” never exceeds the ten-percent threshold for all affected businesses in the various employment size categories. Tables 12 and 13 show that the annual cost of the “HEPA filter” and the “electrostatic precipitator” will also not exceed the ten-percent threshold for affected business in the various employment size categories.⁸

⁸ It is important to note that “catalytic oxidizer,” “HEPA filter” and the “electrostatic precipitator” costs are mutually exclusive, as impacted sources will choose the emission-control solution that is appropriate for their operations. As a result, annual costs and cost-to-net profit ratios expressed in Tables 8 through 10 and Tables 11 through 13 respectively are *not* cumulative.

TABLE 11
Socioeconomic Impact Analysis: Annual Cost to Net Profit Ratio: Industries Subject to Proposed Regulation 6, Rule 2:
Commercial Cooking Equipment: Catalytic Oxidizer

NAICS	Industry Descriptions	Establishments	Est. Nos. of								
			Establishments Subject to Rule Based on Beef Cooked	1-19	20-49	50-99	100-249	250-499	500-999	1000 or more	
7221	Full-Service Restaurants	6,228	114								
	<i>Steakhouse restaurants</i>	146	37	--- na ---	--- na ---	--- na ---	--- na ---	--- na ---	--- na ---	--- na ---	--- na ---
	<i>Other beef-serving full-service restaurants</i>	3,294	71	--- na ---	--- na ---	--- na ---	--- na ---	--- na ---	--- na ---	--- na ---	--- na ---
	<i>Others that primarily serve poultry or fish</i>	209	4	--- na ---	--- na ---	--- na ---	--- na ---	--- na ---	--- na ---	--- na ---	--- na ---
	<i>All others</i>	2,580	1	--- na ---	--- na ---	--- na ---	--- na ---	--- na ---	--- na ---	--- na ---	--- na ---
7222	Limited-Service Eating Places	6,484	277		1.79%	0.90%	0.47%	0.41%	0.21%		
	<i>Fastfood hamburger establishments</i>	667	149	--- na ---	1.79%	1.58%	0.53%	--- na ---	--- na ---	--- na ---	
	<i>Other fastfood establishments</i>	615	14	--- na ---	--- na ---	1.14%	0.80%	--- na ---	--- na ---	--- na ---	
	<i>All other limited service</i>	5,202	114	--- na ---	--- na ---	0.83%	0.42%	0.41%	0.21%	--- na ---	
7223	Special Food Services	636	0	--- na ---	--- na ---	--- na ---	--- na ---	--- na ---	--- na ---	--- na ---	
		13,348	391		1.79%	0.90%	0.47%	0.41%	0.21%		

Source: Applied Development Economics, based on US BLS County Business Patterns (distribution of establishments by size), California EDD (number of establishments), Dun and Bradstreet (establishments by type of restaurants), US Economic Census 2002 (revenue estimates) and US IRS (1999-2004 net profit rates for "food and accommodations" adjusted by revenue amounts).

TABLE 12
Socioeconomic Impact Analysis: Annual Cost to Net Profit Ratio: Industries Subject to Proposed Regulation 6, Rule 2:
Commercial Cooking Equipment: HEPA Filters

NAICS	Industry Descriptions	Establishments	Est. Nos. of								
			Establishments Subject to Rule Based on Beef Cooked	1-19	20-49	50-99	100-249	250-499	500-999	1000 or more	
7221	Full-Service Restaurants	6,228	114				7.51%	2.05%	1.36%		
	<i>Steakhouse restaurants</i>	146	37	--- na ---	--- na ---	7.51%	3.16%	--- na ---	--- na ---	--- na ---	
	<i>Other beef-serving full-service restaurants</i>	3,294	71	--- na ---	--- na ---	--- na ---	2.02%	1.36%	--- na ---	--- na ---	
	<i>Others that primarily serve poultry or fish</i>	209	4	--- na ---	--- na ---	--- na ---	--- na ---	--- na ---	--- na ---	--- na ---	
	<i>All others</i>	2,580	1	--- na ---	--- na ---	--- na ---	--- na ---	--- na ---	--- na ---	--- na ---	
7222	Limited-Service Eating Places	6,484	277								
	<i>Fastfood hamburger establishments</i>	667	149	--- na ---	--- na ---	--- na ---	--- na ---	--- na ---	--- na ---	--- na ---	
	<i>Other fastfood establishments</i>	615	14	--- na ---	--- na ---	--- na ---	--- na ---	--- na ---	--- na ---	--- na ---	
	<i>All other limited service</i>	5,202	114	--- na ---	--- na ---	--- na ---	--- na ---	--- na ---	--- na ---	--- na ---	
7223	Special Food Services	636	0	--- na ---	--- na ---	--- na ---	--- na ---	--- na ---	--- na ---	--- na ---	
		13,348	391				7.51%	2.05%	1.36%		

Source: Applied Development Economics, based on US BLS County Business Patterns (distribution of establishments by size), California EDD (number of establishments), Dun and Bradstreet (establishments by type of restaurants), US Economic Census 2002 (revenue estimates) and US IRS.

Table 13
Socioeconomic Impact Analysis: Annual Cost to Net Profit Ratio: Industries Subject to Proposed Regulation 6, Rule 2:
Commercial Cooking Equipment: Electrostatic Precipitators

NAICS	Industry Descriptions	Establishments	Est. Nos. of	Subject to						
			Rule Based on	1-19	20-49	50-99	100-249	250-499	500-999	1000 or more
7221	Full-Service Restaurants	6,228	114			8.04%	2.19%	1.45%		
	<i>Steakhouse restaurants</i>	146	37	--- na ---	--- na ---	8.04%	3.37%	--- na ---	--- na ---	--- na ---
	<i>Other beef-serving full-service restaurants</i>	3,294	71	--- na ---	--- na ---	--- na ---	2.16%	1.45%	--- na ---	--- na ---
	<i>Others that primarily serve poultry or fish</i>	209	4	--- na ---	--- na ---	--- na ---	--- na ---	--- na ---	--- na ---	--- na ---
	<i>All others</i>	2,580	1	--- na ---	--- na ---	--- na ---	--- na ---	--- na ---	--- na ---	--- na ---
7222	Limited-Service Eating Places	6,484	277							
	<i>Fastfood hamburger establishments</i>	667	149	--- na ---	--- na ---	--- na ---	--- na ---	--- na ---	--- na ---	--- na ---
	<i>Other fastfood establishments</i>	615	14	--- na ---	--- na ---	--- na ---	--- na ---	--- na ---	--- na ---	--- na ---
	<i>All other limited service</i>	5,202	114	--- na ---	--- na ---	--- na ---	--- na ---	--- na ---	--- na ---	--- na ---
7223	Special Food Services	636	0	--- na ---	--- na ---	--- na ---	--- na ---	--- na ---	--- na ---	--- na ---
		13,348	391			8.04%	2.19%	1.45%		

Source: Applied Development Economics, based on US BLS County Business Patterns (distribution of establishments by size), California EDD (number of establishments), Dun and Bradstreet (establishments by type of restaurants), US Economic Census 2002 (revenue estimates) and US IRS (1999-2004 net profit rates for "food and accommodations" adjusted by revenue amounts).

SMALL BUSINESS DISPROPORTIONATE IMPACT ANALYSIS

DEFINITION OF SMALL BUSINESS PER CALIFORNIA STATUTE

For purposes of qualifying small businesses for bid preferences on state contracts and other benefits, the State of California defines small businesses in the following manner:

- Must be independently owned and operated;
- Cannot be dominant in its field of operation;
- Must have its principal office located in California
- Must have its owners (or officers in the case of a corporation) domiciled in California; and,
- Together with its affiliates, be either:
 - A business with 100 or fewer employees, and an average gross receipts of \$10 million or less over the previous tax years, or
 - A manufacturer with 100 or fewer employees

SMALL BUSINESS IMPACT ANALYSIS

The proposed rule is expected to impact some small businesses that are in the category of limited-service restaurants. The compliance costs of the rule will not significantly impact these restaurants. The full-service restaurants that will likely be impacted are not likely to meet the definition of a small business because, as this analysis shows, they will employ more than 100 people. As a result, Regulation 6, Rule 2 does not disproportionately impact small businesses, because small businesses are likely not subject to the rule, or because businesses can bear either the incremental or total annual cost of compliance without any meaningful affects on level of service.

APPENDIX A: ESTIMATING NUMBER OF RESTAURANTS BY TYPE

TABLE A
Estimating Number of Restaurants By Restaurant Types, 2006

NAICS Industry Descriptions	(1) Calif EDD LMID, 2006	(2) Dun and Bradstreet	(3) Est. Nos. Restaurants Based on DD LMID and DnB	(4) Hamburger Fastfood adjustment based on McDonald 2.5 Percent and 42 Percent Metrics
7221 Full-Service Restaurants	6,228		6,228	6,228
<i>Steakhouse restaurants</i>		1.09%	146	146
<i>Other beef-serving full-service restaurants</i>		24.68%	3,294	3,294
<i>Others that primarily serve poultry or fish</i>		1.56%	209	209
<i>All others</i>			2,580	2,580
7222 Limited-Service Eating Places	6,484		6,484	6,484
<i>Fastfood hamburger establishments</i>		1.80%	241	667
<i>Other fastfood establishments</i>		7.80%	1,041	615
<i>All other limited service</i>			5,202	5,202
7223 Special Food Services	636		636	636
	13,348	15,022	13,348	13,348

Source: Applied Development Economics, based on California EDD LMID, Dun and Bradstreet ZAP Data, and McDonalds Corp.

APPENDIX B: ECONOMIC PROFILE OF FOOD SERVICES INDUSTRIES

TABLE B
Economic Profile of Food-Services Industries: Distribution of Establishments By Size of Workforce, 2006

NAICS	Industry Descriptions	Establishments	Employment	1-19	20-49	50-99	100-249	250-499	500-999	1000+
7221	Full-Service	6,228	113,893	28,002	33,287	30,547	21,434	624	0	0
	<i>Steakhouse</i>	146	2,650	655	779	715	502	0	0	0
	<i>Other beef rest.</i>	3,294	60,256	14,810	17,605	16,156	11,336	350	0	0
	<i>Oth poultry- fish</i>	209	3,798	939	1,116	1,024	719	0	0	0
	<i>All others</i>	2,580	47,189	11,598	13,787	12,652	8,878	274	0	0
7222	Limited-Service	6,484	90,784	34,996	43,145	9,253	2,042	674	674	0
	<i>Hamburger</i>	667	9,211	3,604	4,444	953	210			0
	<i>Other fastfood</i>	615	8,475	3,316	4,088	877	193			0
	<i>All others</i>	5,202	73,098	28,076	34,613	7,423	1,638	674	674	0
7223	Special Food Svs	636	12,347	3,308	2,280	1,429	2,629	256	1,372	1,072
		13,348	217,024	66,306	78,712	41,228	26,105	1,529	2,047	1,072

Source: Applied Development Economics, based on US BLS County Business Patterns, California EDD LMID, Dun and Bradstreet ZAP Data

APPENDIX C: AMOUNT OF BEEF PREPARED BY SELECT NATIONAL CHAINS

TABLE C
Estimate of Amount of Beef Prepared By Select National Chain Steakhouse and Hamburger Restaurants

Select Restaurant	Typical Number of Employees Per Restaurant	Typical Revenues	Typical SQFT	Annual Beef (lbs)	Annual Beef (lbs) (pre-cook)	Wkly Beef (lbs)	Daily Beef (lbs)	Annual Beef per worker	Annual Beef per sq ft
Outback	55	\$2,684,121	5,250	46,014	61,351	1,180	169	1,115	12
Sizzler	40	\$1,962,791	5,500	33,648	44,864	863	123	1,133	8
Texas Roadhouse	56	\$2,336,880	6,600	49,529	66,038	1,270	181	1,179	10
Carl's Jr.	26	\$1,345,203	3,250		39,884	767	110	1,530	12
Burger King	30	\$1,272,448	3,100		28,860	555	79	964	9
Steak Group	50	\$2,323,366	5,818	43,431	57,908	1,114	159	1,147	10
Hamburger Group	28	\$1,308,825	3,175		34,372	661	94.5	1,247	10.5

Source: Applied Development Economics, based on corporate annual report of Outback, Sizzler and Texas Roadhouse, Carl's Jr., Burger King (data from various web sources) and BAAQMD

APPENDIX D: AGGREGATE ANNUAL AMOUNT OF PREPARED BEEF

TABLE D
Aggregate Annual Amount of Beef Prepared By Restaurant By Size Category

NAICS	Industry Descriptions	Establishments	1-19	20-49	50-99	100-249	250-499	500-999	1000 or more
7221	Full-Service	6,228	14,618,842	11,235,367	10,310,394	7,234,545	199,342	0	0
	<i>Steakhouse</i>	146	1,159,085	890,819	817,481	573,606	0	0	0
	<i>Other beef rest.</i>	3,294	10,479,825	8,054,310	7,391,223	5,186,236	160,149	0	0
	<i>Oth poultry- fish</i>	209	415,221	319,120	292,848	205,484	0	0	0
	<i>All others</i>	2,580	2,564,711	1,971,118	1,808,842	1,269,219	39,193	0	0
7222	Limited-Service	6,484	32,551,328	29,211,646	6,265,084	1,382,389	331,980	332,202	0
	<i>Hamburger</i>	667	6,078,972	5,455,286	1,170,007	258,162	0	0	0
	<i>Other fastfood</i>	615	2,796,417	2,509,512	538,220	118,758	0	0	0
	<i>All others</i>	5,202	23,675,939	21,246,849	4,556,857	1,005,469	331,980	332,202	0
7223	Special Food Svs	636	3,541,847	1,399,833	876,926	1,613,863	157,435	842,454	658,040
		13,348	50,712,017	41,846,846	17,452,404	10,230,797	688,756	1,174,655	658,040

Source: Applied Development Economics

APPENDIX E: REVENUE-ADJUSTED AFTER-TAX NET PROFIT TRENDS

TABLE E
National Five-Year After Tax Net Profit Trends by Size of Establishments By Revenues:
Food and Accommodations, 1999-2004 Five-Year Average

	\$250,000- \$500,000	\$1,000,000- \$2,500,000	\$2,500,000- \$5,000,000	\$5,000,000- \$10,000,000	\$10,000,000- \$50,000,000	Group Average
Food-Accommodations	0.10%	2.57%	3.54%	2.70%	1.86%	2.15%
Food only (est.)	0.18%	4.73%	6.51%	4.97%	3.43%	3.96%

Source: Applied Development Economics, based on US IRS 1999-2004 for "food and accommodations"

APPENDIX F: AFTER-TAX NET PROFIT TRENDS

TABLE F
National Five-Year After-Tax Net Profit Trends by Eating Establishments Only, 1999-2004

	1999	2000	2001	2002	2003	2004	99-04
Businesses	218,519	222,783	226,206	237,531	242,914	243,964	
Average receipts	\$1,222,284	\$1,261,407	\$1,221,003	\$1,235,098	\$1,220,062	\$1,243,550	\$1,296,791
Net income before taxes rate as percent of receipts	4.83%	4.64%	4.58%	4.10%	4.15%	4.55%	4.07%
Net income after taxes rate as percent of receipts	4.25%	4.07%	3.86%	3.72%	3.74%	4.14%	3.96%

Source: Applied Development Economics, based on US IRS

APPENDIX G: AFTER-TAX NET PROFIT TRENDS: SELECT RESTAURANTS

TABLE G
After-Tax Net Profit Rates Of Select Steakhouse Restaurants

	2003	2004	2005	2006	2003-2006
Outback	6.2%	4.8%	4.1%	2.6%	4.2%
Sizzlers	1.6%	2.3%	1.0%	-6.3%	-0.5%
Texas Roadhouse	8.2%	6.3%	6.7%	5.8%	6.6%

Source: Applied Development Economics, based on corporate annual report of Outback, Sizzler, and Texas Roadhouse

APPENDIX E

Initial Study/Negative Declaration for the Bay Area Air Quality Management District Regulation 6, Rule 2: Commercial Cooking Equipment

Prepared for:

Bay Area Air Quality Management District
939 Ellis Street
San Francisco, CA 94109
Contact: Virginia Lau
(415) 749-4696

Prepared By:

Environmental Audit, Inc.
1000-A Ortega Way
Placentia, CA 92870
Contact: Debra Bright Stevens
(714) 632-8521

October 2007

Chapter 1

Introduction..... 1-1
 Purpose of This Document..... 1-1
 Scope of This Document..... 1-1
 Impact Terminology..... 1-2
 Organization of This Document..... 1-2

Chapter 2

Description of the Proposed Rule 2-1
 Background..... 2-1
 Objectives 2-3
 Proposed Rule 2-3
 Affected Area..... 2-5

Chapter 3

Environmental Checklist Form 3-1
 Environmental Factors Potentially Affected..... 3-2
 Determination 3-2
 I. Aesthetics..... 3-3
 Setting 3-3
 Regulatory Background 3-3
 Discussion of Impacts 3-3
 II. Agriculture Resources..... 3-4
 Setting 3-4
 Regulatory Background 3-5
 Discussion of Impacts 3-5
 III. Air Quality 3-5
 Setting 3-6
 Regulatory Background 3-12
 Discussion of Impacts 3-14
 IV. Biological Resources 3-15
 Setting..... 3-16
 Regulatory Background..... 3-16
 Discussion of Impacts 3-16
 V. Cultural Resources 3-17
 Setting..... 3-17
 Regulatory Background..... 3-18
 Discussion of Impacts 3-18
 VI. Geology and Soils 3-18
 Setting..... 3-19
 Regulatory Background..... 3-20
 Discussion of Impacts 3-20
 VII. Hazard and Hazardous Materials 3-21
 Setting 3-22
 Regulatory Background 3-22
 Discussion of Impacts 3-23

VIII. Hydrology and Water Quality..... 3-24
 Setting 3-25
 Regulatory Background 3-26
 Discussion of Impacts 3-26
 IX. Land Use and Planning 3-28
 Setting 3-28
 Regulatory Background 3-29
 Discussion of Impacts 3-29
 X. Mineral Resources 3-29
 Setting 3-29
 Regulatory Background 3-30
 Discussion of Impacts 3-30
 XI. Noise 3-30
 Setting 3-31
 Regulatory Background 3-31
 Discussion of Impacts 3-31
 XII. Population and Housing 3-31
 Setting 3-32
 Regulatory Background 3-32
 Discussion of Impacts 3-32
 XIII. Public Services 3-33
 Setting 3-33
 Regulatory Background 3-33
 Discussion of Impacts 3-34
 XIV. Recreation 3-34
 Setting 3-34
 Regulatory Background 3-35
 Discussion of Impacts 3-35
 XV. Transportation and Traffic 3-35
 Setting 3-36
 Regulatory Background 3-36
 Discussion of Impacts 3-37
 XVI. Utilities and Service Systems 3-37
 Setting 3-38
 Regulatory Background 3-39
 Discussion of Impacts 3-39
 XVII. Mandatory Findings of Significance 3-40
 Discussion of Impacts 3-40

Chapter 4

References..... 4-1

FIGURES:

Figure 1 – Bay Area Air Quality Management District..... 2-6

TABLES:

Table 2-1	Emissions from Charbroilers in the Bay Area	2-2
Table 3-1	Federal and State Ambient Air Quality Standards.....	3-9
Table 3-2	Bay Area Air Pollution Summary 2006.....	3-10
Table 3-3	Bay Area Air Quality Summary	3-11
Table 3-4	Summary of Bay Area Toxic Air Contaminant Monitoring Data - 2002.....	3-12

HLH\2519-BAAQMD-\2519-R6TOC.doc

Chapter 1

Introduction

Purpose of this Document

This Initial Study/Negative Declaration (IS/ND) assesses the environmental impacts of the proposed adoption of Regulation 6, Rule 2, by the Bay Area Air Quality Management District (BAAQMD or District). This assessment is required by the California Environmental Quality Act (CEQA) and in compliance with the state CEQA Guidelines (Title 14 California Code of Regulations §1400 et seq.). An IS/ND serves as an informational document to be used in the decision-making process for a public agency that intends to carry out a project; it does not recommend approval or denial of the project analyzed in the document. The BAAQMD is the lead agency under CEQA and must consider the impacts of the proposed rule when determining whether to adopt it. The BAAQMD has prepared this IS/ND because no significant adverse impacts would result from the proposed rule.

Scope of this Document

This document evaluates the potential impacts of the proposed amendments on the following resource areas:

- aesthetics,
- agricultural resources,
- air quality,
- biological resources,
- cultural resources,
- geology and soils,
- hazards and hazardous materials
- hydrology and water quality,
- land use planning,
- mineral resources,
- noise,

- population and housing,
- public services,
- recreation,
- transportation and traffic, and
- utilities and service systems.

Impact Terminology

The following terminology is used in this IS/ND to describe the levels of significance of impacts that would result from the proposed rule:

- An impact is considered *beneficial* when the analysis concludes that the project would have a positive effect on a particular resource.
- A conclusion of *no impact* is appropriate when the analysis concludes that there would be no impact on a particular resource from the proposed project.
- An impact is considered *less than significant* if the analysis concludes that an impact on a particular resource topic would not be significant (i.e., would not exceed certain criteria or guidelines established by BAAQMD). Impacts are frequently considered less than significant when the changes are minor relative to the size of the available resource base or would not change an existing resource.
- An impact is considered *less than significant with mitigation incorporated* if the analysis concludes that an impact on a particular resource topic would be significant (i.e., would exceed certain criteria or guidelines established by BAAQMD), but would be reduced to a less than significant level through the implementation of mitigation measures.

Organization of This Document

The content and format of this document, described below, are designed to meet the requirements of CEQA.

- Chapter 1, “Introduction,” identifies the purpose, scope, and terminology of the document.
- Chapter 2, “Description of the Proposed Rule,” provides background information of Regulation 6, Rule 2, describes the proposed rule, and describes the area and facilities that would be affected by the rule.
- Chapter 3, “Environmental Checklist,” presents the checklist responses for each resource topic. This chapter includes a brief setting description for each resource

area and identifies the impact of the proposed rule amendments on the resources topics listed in the checklist.

- Chapter 4, “References Cited,” identifies all printed references and personal communications cited in this report.

DBS:2519:2519-R6R2Ch1NegDec.doc

Chapter 2

Description of the Proposed Rule

Background

The Bay Area Air Quality Management District (District) is proposing adoption of Regulation 6, Rule 2 (Rule 6-2): Commercial Cooking Equipment. This proposed rule would control air pollution from charbroilers used in commercial restaurants. The District proposes adoption of Regulation 6, Rule 2 to fulfill a commitment proposed in its Senate Bill (SB) 656 Particulate Matter Implementation Schedule, and in connection with Further Study Measure (FS) 3 in the District's 2005 Ozone Strategy, which proposes evaluation of a rule to control emissions from commercial charbroilers.

Currently, no District rule directly regulates emissions from restaurants although restaurants vent substantial amounts of particulate matter (PM) and volatile organic compounds (VOCs) into the atmosphere. Restaurants, cafeterias, and other food establishments are exempt from obtaining a permit to operate under the District's Regulation 2, Rule 1. Nevertheless, restaurants must comply with District's regulations of general applicability, such as Regulation 6: *Particular Matter and Visible Emissions*, and Regulation 7: *Odorous Substances*.

Proposed Regulation 6, Rule 2 would regulate two types of charbroilers: chain-driven and under-fired. A chain-driven (conveyorized) charbroiler is a semi-enclosed broiler designed to move food mechanically on a grated grill through the device as the food cooks. Food cooks quickly, because chain-driven charbroilers have burners located both above and below the grill. Chain-driven charbroilers are most common in fast food restaurants.

In an under-fired charbroiler, the heat source is positioned at or below the level of the grated grill. Designs of under-fired charbroilers vary widely. Some under-fired broilers use charcoal or wood for fuel, but usually, the broilers are fueled by gas or electricity. In gas under-fired charbroilers, a radiant surface, such as a bed of ceramic briquettes or a metal shield, placed above the burners diffuses heat from the burners. The heating elements of electric charbroilers are often interwoven with, or sheathed inside, the grill. Under-fired charbroilers are common in fine dining and casual restaurants.

Charbroilers produce air pollutants through incomplete combustion of grease and meat additives, such as tenderizers and marinade. The air contaminants are released when grease and meat additives fall onto the heat source, radiant surface, or hot plate, or when grease flares in the drip tray or bubbles at the surface.

The smoke and vapors generated from the process contain VOC and PM that consist of aldehydes, organic acids, alcohol, nitrogen and sulfur compounds, and polycyclic

aromatic hydrocarbons (PAHs). Every day in the Bay Area, cooking operations collectively (commercial and non-commercial) emit an estimated 6.9 tons of PM and 1.1 tons of VOC. VOC reacts with other compounds in the atmosphere to form ground-level ozone, commonly called smog. PM consists of airborne particles. PM can be emitted directly and also can be formed in the atmosphere through chemical reactions between other pollutants, including VOC. Cooking emissions include fine particles that are equal to or less than 10 microns in diameter, commonly referred to as PM₁₀. PM₁₀ generated by cooking appliances passes through the ventilation system and is exhausted into the atmosphere.

Both VOC and PM₁₀ present public health risks. Ozone produced from chemical reactions involving VOC may damage lung tissues and the respiratory tract. Once inhaled, PM₁₀ may become lodged in the respiratory tract and lead to wheezing, nose and throat irritation, bronchitis, and lung damage.

In order to determine the emissions from restaurant cooking, the District reviewed several studies sponsored by the South Coast Air Quality Management District and the California Air Resources Board (CARB) to determine the percentage of restaurants that use charbroilers, the amount and type of meat cooked on charbroilers, and the amount of PM₁₀ and VOC produced from meat cooked on charbroilers. The District relied on these research studies, and on information provided by the health department of each of the nine Bay Area counties, to estimate the amount of PM₁₀ and VOC emitted from restaurant charbroilers in the Bay Area. The District estimates that there are approximately 14,838 restaurants in the Bay Area, 4,897 of which operate under-fired charbroilers while 554 restaurants operate chain-driven charbroilers. The estimated emissions of VOC and PM₁₀ by type of appliance are shown in Table 2-1.

Table 2-1. Emissions from Charbroilers in the Bay Area

Type of Food	Chain-driven Broiler		Under-Fired Broiler	
	PM10 (tons/day)	VOC (tons/day)	PM10 (tons/day)	VOC (tons/day)
Hamburger	0.23	0.072	0.90	0.37
Steaks	0.069	0.021	0.60	0.25
Poultry with Skin	0.0091	0.0061	0.10	0.092
Poultry without Skin	0.016	0.011	0.12	0.11
Pork	0.0036	0.0024	0.10	0.094
Seafood	0.012	0.010	0.16	0.019
Total Emissions (tons/day)	0.34	0.11	2.0	0.94
Total Emissions (tons/year)	126	41	724	342

In addition to VOC and PM emissions, combustion products from cooking operations include carbon dioxide (CO₂), a gas contributing to climate change. The District estimates that the average CO₂ emissions for cooking activities per restaurant are

approximately 25,000 pounds annually based on operation of the cooking appliances and associated ventilation equipment.

Objectives

The objective of Rule 6-2 is to reduce PM₁₀ and VOC emissions from commercial cooking equipment in order to reduce particulate matter and ozone levels in the Bay Area. The Bay Area is not in attainment with the State particulate matter and ozone standards, so further reductions in emissions of PM and ozone precursors are needed.

The Bay Area attains the federal annual PM₁₀ (particulate matter of 10 microns or less in diameter) and federal annual PM_{2.5} (particulate matter of 2.5 microns or less in diameter) standards, but is not in attainment of the California annual PM₁₀ or PM_{2.5} or the California 24-hour PM₁₀ standard. The Bay Area is unclassified for the federal 24-hour PM₁₀ or new PM_{2.5} standard.

The BAAQMD is not required to produce an attainment plan for particulate matter. However, under the requirements of Senate Bill 656 (SB 656, Sher), adopted in 2003, the District is required to develop a Particulate Matter Implementation Schedule in order to make progress toward attaining state and federal PM standards. The proposed Rule 6-2 was included in the District's PM Implementation Schedule as one of the measures that the BAAQMD could adopt to reduce particulate matter.

The U.S. Environmental Protection Agency (U.S. EPA) has set primary national ambient air quality standards for ozone and other air pollutants to define the levels considered safe for human health. The California Air Resources Board (CARB) has also set California air quality standards. The Bay Area is a non-attainment area for the state one-hour and eight-hour standards and new federal eight-hour standard. Under State law, non-attainment areas must prepare plans showing how they will attain the state standard. The 2005 Ozone Strategy is the most recent planning document for the State one-hour ozone standard. Because the Bay Area is a marginal non-attainment area for the national eight-hour standard, the least severe non-attainment classification, the BAAQMD is not required to prepare an attainment plan for the national standard.

The 2005 Ozone Strategy includes measures to reduce emissions of the pollutants that form ozone, i.e., nitrogen oxides and volatile organic compounds. These measures may be proposals to adopt new regulations or amendments to existing regulations. The 2005 Ozone Strategy also includes further study measures. Further study measures require additional analysis before the District can determine whether to proceed with rulemaking or implementation. Further study measure FS 3 proposed examining potential control of emissions from commercial charbroilers.

Proposed Rule

The District is proposing Regulation 6, Rule 2 to achieve the maximum feasible PM₁₀ and VOC reduction produced from commercial charbroilers to reduce particulate matter and ground level ozone in the Bay Area.

Chain-Driven Charbroilers: Proposed Regulation 6, Rule 2 requires that, within one year of adoption of the rule, chain-driven charbroilers in the District at restaurants that purchase at least 500 lbs. of beef per week be equipped and operated with a District-approved catalytic oxidizer or other certified control, unless the operator can demonstrate that less than 400 lbs. of beef is cooked on the charbroiler per week. The South Coast Air Quality Management District (SCAQMD) has already approved catalytic oxidizers from a variety of manufacturers to meet the same standard that the rule proposes, 1.3 lbs. PM₁₀ and 0.32 lbs. organic compounds per 1,000 lbs. of beef cooked. SCAQMD-approved oxidizers will be approved for use in the Bay Area. New catalytic oxidizers will be required to be certified to meet the emission standard following the SCAQMD protocol. In the alternative, the proposed rule allows a restaurant operator the flexibility to install an alternative control device, provided the device has been approved by the District for use under the rule and certified by the manufacturer to reduce emissions to no more than 0.74 lbs. of PM₁₀ per 1,000 lbs. of meat cooked. Before a restaurant operator may install and operate an alternative control, the manufacturer of the control is required to have an independent laboratory certify the performance of the control equipment in accordance with specific procedures prescribed in the rule, to determine the ability of the control to meet the emission standards the rule requires.

New Under-Fired Charbroilers: The proposed standard calls for any owner or operator who, starting two years after adoption of this rule, installs any under-fired charbroiler in a restaurant such that the restaurant's under-fired charbroilers, taken together, have a total grill surface area of at least 10 square feet, and when the restaurant purchases at least 1000 lbs of beef per week, to exhaust charbroiler emissions through a control device certified by the manufacturer to limit charbroiler emissions to no more than 1.0 lbs. of PM₁₀ per 1,000 lbs. of meat cooked. An exemption is provided if the operator can demonstrate that less than 800 lbs. of the beef is charbroiled per week. Owners of an existing restaurant who choose to install one or more additional under-fired charbroiler(s) in the restaurant and thereby become subject to the rule will have to install an approved control device. Alternatively, the restaurant owner may elect to install cooking equipment other than an under-fired charbroiler, such as a clamshell griddle or over-fired charbroiler, that emits much less PM than an under-fired charbroiler, and consequently, is not subject to the regulation.

Existing Under-Fired Charbroilers: Starting five years after rule adoption, the proposed rule requires all restaurants with under-fired charbroilers with an aggregate grill surface area of at least 10 square feet that purchase at least 1000 lbs of beef per week to install a control technology certified by the control device manufacturer to emit no more than 1.0 lbs. of PM₁₀ per 1,000 lbs. of meat cooked unless the operator can demonstrate that less than 800 lbs of the beef per week is charbroiled.

Administrative Requirements: All operators of chain-driven charbroilers and under-fired charbroilers subject to the control requirements will be required to register their operation with the District, as specified in the proposed regulation. The District will implement a web-based registration system to simplify the registration process. Controls

that have already been approved for use in the District will be listed on the District web site. Restaurant owners will be assessed an initial registration fee of \$360 and recurring annual fee of \$100 to recover the District's costs of administering and enforcing the proposed rule. The proposed rule also has a recordkeeping provision that requires owners and operators to record the date of installation of, and any maintenance and repairs performed on, the control device. The repair logs will contain the date, time, and description of the work that was performed. The owner or operator must keep the records for at least five years. The purpose of these recordkeeping requirements is to ensure that the control is operated in accordance with the manufacturer's specifications. Finally, the owner or operator must be able to verify the amount of beef cooked on charbroiler at the restaurant, if the restaurant operates under an exemption.

Proposed Regulation 6, Rule 2 is intended to be considered by the Bay Area Air Quality Management District Board of Directors in conjunction with proposed amendments to District Regulation 3: Fees, Schedule R: Equipment Registration Fees; and Regulation 6: Particulate Matter and Visible Emissions. Regulation 3 is a fee regulation; fees are exempt from CEQA pursuant to State CEQA Guidelines, Sections 15061, subd. (b)(3) and 15273. The proposed changes to Regulation 6 renumber and rename the rule; they do not have any substantive effect. There is no possibility that the changes to Regulation 3, Schedule R or to Regulation 6 could have any impact on the environment. This analysis only discusses potential impacts of proposed Regulation 6, Rule 2.

Affected Area

The proposed rule amendments would apply to restaurants within the BAAQMD jurisdiction. The BAAQMD jurisdiction includes all of Alameda, Contra Costa, Marin, San Francisco, San Mateo, Santa Clara, and Napa Counties and portions of southwestern Solano and southern Sonoma counties (approximately 5,600 square miles). The San Francisco Bay Area is characterized by a large, shallow basin surrounded by coastal mountain ranges tapering into sheltered inland valleys. The combined climatic and topographic factors result in increased potential for the accumulation of air pollutants in the inland valleys and reduced potential for buildup of air pollutants along the coast. The Basin is bounded by the Pacific Ocean to the west and includes complex terrain consisting of coastal mountain ranges, inland valleys, and bays.

The facilities affected by the proposed rule amendments are located within the jurisdiction of the Bay Area Air Quality Management District (see Figure 1).

M;DBS:2519:2519-R6R2Ch2-ProjDesc.doc

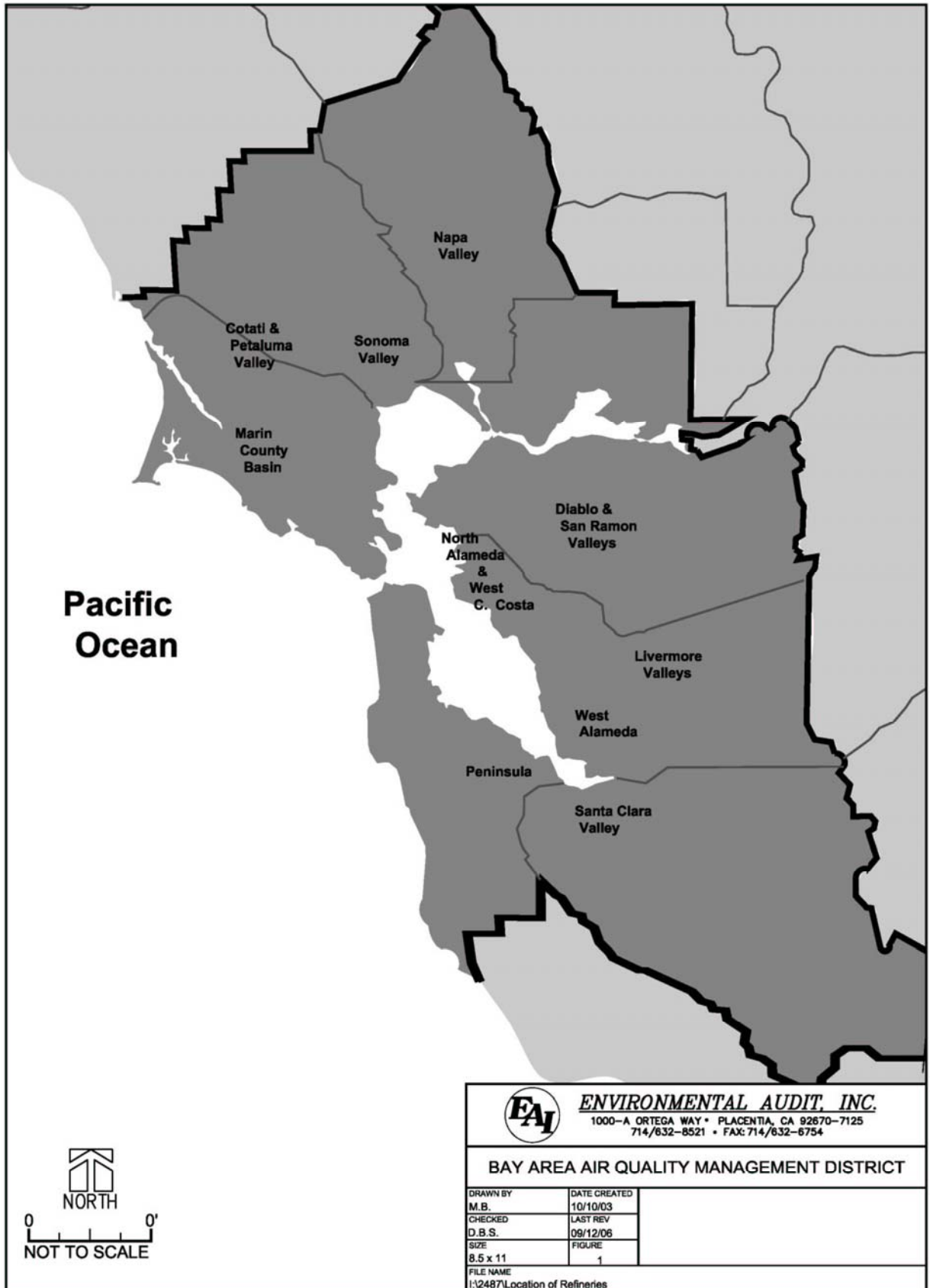

Chapter 3

Environmental Checklist**ENVIRONMENTAL CHECKLIST FORM**

- 1. Project Title:** Bay Area Air Quality Management District (BAAQMD) Proposed Regulation 6, Rule 2: Commercial Cooking Equipment.
- 2. Lead Agency Name and Address:** Bay Area Air Quality Management District
939 Ellis Street
San Francisco, California 94109
- 3. Contact Person and Phone Number:** Virginia Lau, Planning, Rules and Research Division
415/749-4696 or vlau@baaqmd.gov
- 4. Project Location:** The proposed rule applies to the area within the jurisdiction of the Bay Area Air Quality Management District, which encompasses all of Alameda, Contra Costa, Marin, San Francisco, San Mateo, Santa Clara, and Napa Counties and portions of southwestern Solano and southern Sonoma Counties.
- 5. Project Sponsor's Name and Address:** Bay Area Air Quality Management District
939 Ellis Street
San Francisco, California 94109
- 6. General Plan Designation:** The proposed rule applies to facilities with commercial cooking equipment that are usually located in commercial areas.
- 7. Zoning** The proposed rule applies to facilities with commercial cooking equipment that are usually located in commercially zoned areas.
- 8. Description of Project** See "Background" in Chapter 2.
- 9. Surrounding Land Uses and Setting** See "Affected Area" in Chapter 2.
- 10. Other Public Agencies Whose Approval Is Required** None

Environmental Factors Potentially Affected:

The environmental factors checked below would potentially be affected by this Project (i.e., the project would involve one impact that is a “Potentially Significant Impact”), as indicated by the checklist on the following pages.

- | | | |
|--|---|---|
| <input type="checkbox"/> Aesthetics | <input type="checkbox"/> Agriculture Resources | <input type="checkbox"/> Air Quality |
| <input type="checkbox"/> Biological Resources | <input type="checkbox"/> Cultural Resources | <input type="checkbox"/> Geology/Soils |
| <input type="checkbox"/> Hazards & Hazardous Materials | <input type="checkbox"/> Hydrology/Water Quality | <input type="checkbox"/> Land Use/Planning |
| <input type="checkbox"/> Mineral Resources | <input type="checkbox"/> Noise | <input type="checkbox"/> Population/Housing |
| <input type="checkbox"/> Public Services | <input type="checkbox"/> Recreation | <input type="checkbox"/> Transportation/Traffic |
| <input type="checkbox"/> Utilities/Service Systems | <input type="checkbox"/> Mandatory Findings of Significance | |

Determination:

On the basis of this initial evaluation:

- I find the proposed project COULD NOT have a significant effect on the environment, and that a NEGATIVE DECLARATION will be prepared.
- I find that although the proposed project could have a significant effect on the environment, there will not be significant effects in this case because revisions to the project have been made by or agreed to by the project proponent. A MITIGATED NEGATIVE DECLARATION will be prepared.
- I find that the proposed project MAY have a significant effect on the environment, and an ENVIRONMENTAL IMPACT REPORT is required.
- I find that the proposed project MAY have an impact on the environment that is "potentially significant" or "potentially significant unless mitigated" but at least one effect (1) has been adequately analyzed in an earlier document pursuant to applicable legal standards and (2) has been addressed by mitigation measures based on the earlier analysis as described on attached sheets. An ENVIRONMENTAL IMPACT REPORT is required, but it must analyze only the effects that remain to be addressed.
- I find that although the proposed project could have a significant effect on the environment, because all potentially significant effects (a) have been analyzed adequately in an earlier ENVIRONMENTAL IMPACT REPORT or NEGATIVE DECLARATION, pursuant to applicable standards, and (b) have been avoided or mitigated pursuant to that earlier ENVIRONMENTAL IMPACT REPORT or NEGATIVE DECLARATION, including revisions or mitigation measures that are imposed upon the proposed project, nothing further is required.

Signature

Date

Printed Name

For

	Potentially Significant Impact	Less Than Significant Impact With Mitigation Incorporated	Less-than-Significant Impact	No Impact
I. AESTHETICS.				
Would the project:				
a) Have a substantial adverse effect on a scenic vista?	<input type="checkbox"/>	<input type="checkbox"/>	<input type="checkbox"/>	<input checked="" type="checkbox"/>
b) Substantially damage scenic resources, including, but not limited to, trees, rock outcroppings, and historic buildings along a scenic highway?	<input type="checkbox"/>	<input type="checkbox"/>	<input type="checkbox"/>	<input checked="" type="checkbox"/>
c) Substantially degrade the existing visual character or quality of the site and its surroundings?	<input type="checkbox"/>	<input type="checkbox"/>	<input type="checkbox"/>	<input checked="" type="checkbox"/>
d) Create a new source of substantial light or glare that would adversely affect daytime or nighttime views in the area?	<input type="checkbox"/>	<input type="checkbox"/>	<input type="checkbox"/>	<input checked="" type="checkbox"/>

Setting

The BAAQMD covers all of Alameda, Contra Costa, Marin, San Francisco, San Mateo, Santa Clara, and Napa Counties and portions of southwestern Solano and southern Sonoma Counties. The area of coverage is vast (about 5,600 square miles), so that land uses vary greatly and include commercial, industrial, residential, agricultural, and open space uses

Many of the facilities with commercial cooking equipment affected by the proposed rule are located in commercial and areas throughout the Bay Area.

Regulatory Background

Visual resources are generally protected by the City and/or County General Plans through land use and zoning requirements.

Discussion of Impacts

I a-d. The proposed Regulation 6, Rule 2 (Rule 6-2) would further reduce PM and VOC emissions from commercial cooking equipment in order to reduce ozone levels and particulate matter in the Bay Area. The catalytic oxidizer system is semi-enclosed and situated above the restaurant charbroiler which is located inside a facility. The installation of the catalytic oxidizer will not create any noticeable changes in the visual characteristics of commercial cooking facilities. Under-fired charbroilers are expected to be controlled by use of a roof-mounted

control device such as a HEPA filter or electrostatic precipitator. These devices are expected to be integrated into the existing ducting and would not rise significantly above the level of existing ductwork and exhaust fans.

Likewise, additional light or glare would not be created since the proposed rule would not require additional light generating equipment. Therefore, no adverse significant aesthetic impacts are expected due to the proposed project.

	Potentially Significant Impact	Less Than Significant Impact With Mitigation Incorporated	Less Than Significant Impact	No Impact
--	--------------------------------	---	------------------------------	-----------

II. AGRICULTURE RESOURCES.

In determining whether impacts on agricultural resources are significant environmental effects, lead agencies may refer to the California Agricultural Land Evaluation and Site Assessment Model (1997) prepared by the California Department of Conservation. Would the project:

- | | | | | |
|--|--------------------------|--------------------------|--------------------------|-------------------------------------|
| a) Convert Prime Farmland, Unique Farmland, or Farmland of Statewide Importance (Farmland), as shown on the maps prepared pursuant to the Farmland Mapping and Monitoring Program of the California Resources Agency, to non-agricultural use? | <input type="checkbox"/> | <input type="checkbox"/> | <input type="checkbox"/> | <input checked="" type="checkbox"/> |
| b) Conflict with existing zoning for agricultural use or conflict with a Williamson Act contract? | <input type="checkbox"/> | <input type="checkbox"/> | <input type="checkbox"/> | <input checked="" type="checkbox"/> |
| c) Involve other changes in the existing environment that, due to their location or nature, could result in conversion of Farmland, to non-agricultural use? | <input type="checkbox"/> | <input type="checkbox"/> | <input type="checkbox"/> | <input checked="" type="checkbox"/> |

Setting

The BAAQMD covers all of Alameda, Contra Costa, Marin, San Francisco, San Mateo, Santa Clara, and Napa Counties and portions of southwestern Solano and southern Sonoma Counties. The area of coverage is vast (about 5,600 square miles) so that land uses vary greatly and include commercial, industrial, residential, agricultural, and open space uses. Some of these agricultural lands are under Williamson Act contracts.

The facilities with commercial cooking equipment affected by the proposed rule are located in commercial areas throughout the Bay Area. Agricultural resources are generally not located in the vicinity of commercial areas.

Regulatory Background

Agricultural resources are generally protected by the City and/or County General Plans, Community Plans through land use and zoning requirements, as well as any applicable specific plans, ordinances, local coastal plans, and redevelopment plans.

Discussion of Impacts

II a-c. The proposed Rule 6-2 would further reduce PM and VOC emissions from commercial cooking equipment in order to reduce particulate matter and ozone levels in the Bay Area. Installation of catalytic oxidizers or equivalent control devices on chain-driven charboilers or control devices integrated into the ductwork to control under-fired charbroilers would not result in increasing the size of the commercial cooking facilities or result in additional construction activities outside of the confines of the current commercial cooking facility, with the exception of work on the roof to install roof-mounted control devices. Further, commercial cooking facilities are generally located in commercially zone areas, so no impact on agricultural resources is expected. Therefore, no adverse significant impacts to agricultural resources are expected due to the proposed project.

	Potentially Significant Impact	Less Than Significant Impact With Mitigation Incorporated	Less Than Significant Impact	No Impact
--	--------------------------------	---	------------------------------	-----------

III. AIR QUALITY

When available, the significance criteria established by the applicable air quality management or air pollution control district may be relied upon to make the following determinations. Would the project:

a) Conflict with or obstruct implementation of the applicable air quality plan?	<input type="checkbox"/>	<input type="checkbox"/>	<input type="checkbox"/>	<input checked="" type="checkbox"/>
b) Violate any air quality standard or contribute to an existing or projected air quality violation?	<input type="checkbox"/>	<input type="checkbox"/>	<input type="checkbox"/>	<input checked="" type="checkbox"/>
c) Result in a cumulatively considerable net increase of any criteria pollutant for which the project region is a non-attainment area for an applicable federal or state ambient air quality standard (including releasing emissions that exceed quantitative thresholds for ozone precursors)?	<input type="checkbox"/>	<input type="checkbox"/>	<input type="checkbox"/>	<input checked="" type="checkbox"/>
d) Expose sensitive receptors to substantial pollutant concentrations?	<input type="checkbox"/>	<input type="checkbox"/>	<input type="checkbox"/>	<input checked="" type="checkbox"/>

- | | | | | | |
|----|---|--------------------------|--------------------------|--------------------------|-------------------------------------|
| e) | Create objectionable odors affecting a substantial number of people? | <input type="checkbox"/> | <input type="checkbox"/> | <input type="checkbox"/> | <input checked="" type="checkbox"/> |
| f) | Diminish an existing air quality rule or future compliance requirement resulting in a significant increase in air pollutant(s)? | <input type="checkbox"/> | <input type="checkbox"/> | <input type="checkbox"/> | <input checked="" type="checkbox"/> |

Setting

Meteorological Conditions

The summer climate of the West Coast is dominated by a semi-permanent high centered over the northeastern Pacific Ocean. Because this high pressure cell is quite persistent, storms rarely affect the California coast during the summer. Thus the conditions that persist along the coast of California during summer are a northwest air flow and negligible precipitation. A thermal low pressure area from the Sonoran-Mojave Desert also causes air to flow onshore over the San Francisco Bay Area much of the summer.

In winter, the Pacific High weakens and shifts southward, upwelling ceases, and winter storms become frequent. Almost all of the Bay Area’s annual precipitation takes place in the November through April period. During the winter rainy periods, inversions are weak or nonexistent, winds are often moderate and air pollution potential is very low. During winter periods when the Pacific high becomes dominant, inversions become strong and often are surface based; winds are light and pollution potential is high. These periods are characterized by winds that flow out of the Central Valley into the Bay Area and often include fog.

Topography

The San Francisco Bay Area is characterized by complex terrain consisting of coastal mountain ranges, inland valleys and bays. Elevations of 1,500 feet are common in the higher terrain of this area. Normal wind flow over the area becomes distorted in the lower elevations, especially when the wind velocity is not strong. This distortion is reduced when stronger winds and unstable air masses move over the areas. The distortion is greatest when low level inversions are present with the surface air, beneath the inversion, flowing independently of the air above the inversion.

Winds

In summer, the northwest winds to the west of the Pacific coastline are drawn into the interior through the Golden Gate and over the lower portions of the San Francisco Peninsula. Immediately to the south of Mount Tamalpais, the northwesterly winds accelerate considerably and come more nearly from the west as they stream through the Golden Gate. This channeling of the flow through the Golden Gate produces a jet that sweeps eastward but widens downstream producing southwest winds at Berkeley and northwest winds at San Jose; a branch curves eastward through the Carquinez Straits and into the Central Valley. Wind speeds may be locally strong in regions where air is channeled through a narrow opening such as the Carquinez Strait, the Golden Gate, or San Bruno Gap.

In winter, the Bay Area experiences periods of storminess and moderate-to-strong winds and periods of stagnation with very light winds. Winter stagnation episodes are characterized by outflow from the Central Valley, nighttime drainage flows in coastal valleys, weak onshore flows in the afternoon and otherwise light and variable winds.

Temperature

In summer, the distribution of temperature near the surface over the Bay Area is determined in large part by the effect of the differential heating between land and water surfaces. This process produces a large-scale gradient between the coast and the Central Valley as well as small-scale local gradients along the shorelines of the ocean and bays. The winter mean temperature high and lows reverse the summer relationship; daytime variations are small while mean minimum nighttime temperatures show large differences and strong gradients. The moderating effect of the ocean influences warmer minimums along the coast and penetrating the Bay. The coldest temperatures are in the sheltered valleys, implying strong radiation inversions and very limited vertical diffusion.

Inversions

A primary factor in air quality is the mixing depth, i.e., the vertical dimension available for dilution of contaminant sources near the ground. Over the Bay Area the frequent occurrence of temperature inversions limits this mixing depth and consequently limits the availability of air for dilution. A temperature inversion may be described as a layer or layers of warmer air over cooler air.

Precipitation

The San Francisco Bay Area climate is characterized by moderately wet winters and dry summers. Winter rains (December through March) account for about 75 percent of the average annual rainfall; about 90 percent of the annual total rainfall is received in November to April period; and between June and September, normal rainfall is typically less than 0.10 inches. Annual precipitation amounts show greater differences in short distances. Annual totals exceed 40 inches in the mountains and are less than 15 inches in the sheltered valleys.

Pollution Potential

The Bay Area is subject to a combination of physiographic and climatic factors which result in a low potential for pollutant buildups near the coast and a high potential in sheltered inland valleys. In summer, areas with high average maximum temperatures tend to be sheltered inland valleys with abundant sunshine and light winds. Areas with low average maximum temperatures are exposed to the prevailing ocean breeze and experience frequent fog or stratus. Locations with warm summer days have a higher pollution potential than the cooler locations along the coast and bays.

In winter, pollution potential is related to the nighttime minimum temperature. Low minimum temperatures are associated with strong radiation inversions in inland valleys that are protected from the moderating influences of the ocean and bays. Conversely, coastal locations experience higher average nighttime temperatures, weaker inversions, stronger breezes and consequently less air pollution potential.

Air Quality

Criteria Pollutants

It is the responsibility of the BAAQMD to ensure that State and federal ambient air quality standards are achieved and maintained in its geographical jurisdiction. Health-based air quality standards have been established by California and the federal government for the following criteria air pollutants: ozone, carbon monoxide (CO), nitrogen dioxide (NO₂), particulate matter less than 10 microns in diameter (PM₁₀), particulate matter less than 2.5 microns in diameter (PM_{2.5}), sulfur dioxide (SO₂) and lead. These standards were established to protect sensitive receptors with a margin of safety from adverse health impacts due to exposure to air pollution. The California standards are more stringent than the federal standards. California has also established standards for sulfate, visibility, hydrogen sulfide, and vinyl chloride.

The State and national ambient air quality standards for each of these pollutants and their effects on health are summarized in Table 3-1. The BAAQMD monitors levels of various criteria pollutants at 26 monitoring stations. The 2006 air quality data from the BAAQMD's monitoring stations are presented in Table 3-2.

Air quality conditions in the San Francisco Bay Area have improved since the Air District was created in 1955. Ambient concentrations of air pollutants and the number of days on which the region exceeds air quality standards have fallen dramatically (see Table 3-3). The Air District is in attainment of the State and federal ambient air quality standards for CO, nitrogen dioxide (NO₂), and sulfur dioxide (SO₂). The Air District is not considered to be in attainment with the State PM₁₀ and PM_{2.5} standards, and is unclassified for the new federal 24-hour PM_{2.5} standard.

The 2006 air quality data from the BAAQMD monitoring stations are presented in Table 3-2. All monitoring stations were below the standard and federal ambient air quality standards for CO, NO₂, and SO₂. The federal eight-hour standard was exceeded on 12 days in the District in 2006. The Bay Area is designated as a non-attainment area for the California one-hour ozone standard. The State one-hour ozone standard was exceeded in the District on 18 days in 2006; most frequently in the Eastern District (Livermore) (see Table 3-2).

All monitoring stations were in compliance with the federal PM₁₀ standards. The California PM₁₀ standards were exceeded on 15 days in 2006, most frequently in San Jose. The Air District exceeded the federal PM_{2.5} standard on 10 days in 2006, also most frequently in San Jose (see Table 3-2).

**TABLE 3-1
FEDERAL AND STATE AMBIENT AIR QUALITY STANDARDS**

AIR POLLUTANT	STATE STANDARD CONCENTRATION/ AVERAGING TIME	FEDERAL PRIMARY STANDARD CONCENTRATION/ AVERAGING TIME	MOST RELEVANT EFFECTS
Ozone	0.09 ppm, 1-hr. avg. > 0.070 ppm, 8-hr	0.08 ppm, 8-hr avg. >	(a) Short-term exposures: (1) Pulmonary function decrements and localized lung edema in humans and animals (2) Risk to public health implied by alterations in pulmonary morphology and host defense in animals; (b) Long-term exposures: Risk to public health implied by altered connective tissue metabolism and altered pulmonary morphology in animals after long-term exposures and pulmonary function decrements in chronically exposed humans; (c) Vegetation damage; (d) Property damage
Carbon Monoxide	9.0 ppm, 8-hr avg. > 20 ppm, 1-hr avg. >	9 ppm, 8-hr avg.> 35 ppm, 1-hr avg.>	(a) Aggravation of angina pectoris and other aspects of coronary heart disease; (b) Decreased exercise tolerance in persons with peripheral vascular disease and lung disease; (c) Impairment of central nervous system functions; (d) Possible increased risk to fetuses
Nitrogen Dioxide	0.25 ppm, 1-hr avg. >	0.053 ppm, ann. avg.>	(a) Potential to aggravate chronic respiratory disease and respiratory symptoms in sensitive groups; (b) Risk to public health implied by pulmonary and extra-pulmonary biochemical and cellular changes and pulmonary structural changes; (c) Contribution to atmospheric discoloration
Sulfur Dioxide	0.04 ppm, 24-hr avg.> 0.25 ppm, 1-hr. avg. >	0.03 ppm, ann. avg.> 0.14 ppm, 24-hr avg.>	(a) Bronchoconstriction accompanied by symptoms which may include wheezing, shortness of breath and chest tightness, during exercise or physical activity in persons with asthma
Suspended Particulate Matter (PM10)	20 µg/m ³ , annarithmic mean > 50 µg/m ³ , 24-hr average>	50 µg/m ³ , annual arithmetic mean > 150 µg/m ³ , 24-hr avg.>	(a) Excess deaths from short-term exposures and exacerbation of symptoms in sensitive patients with respiratory disease; (b) Excess seasonal declines in pulmonary function, especially in children
Suspended Particulate Matter (PM2.5)	12 µg/m ³ , annual arithmetic mean>	15 µg/m ³ , annual arithmetic mean> 35 µg/m ³ , 24-hour average>	Decreased lung function from exposures and exacerbation of symptoms in sensitive patients with respiratory disease; elderly; children.
Sulfates	25 µg/m ³ , 24-hr avg. >=		(a) Decrease in ventilatory function; (b) Aggravation of asthmatic symptoms; (c) Aggravation of cardio-pulmonary disease; (d) Vegetation damage; (e) Degradation of visibility; (f) Property damage
Lead	1.5 µg/m ³ , 30-day avg. >=	1.5 µg/m ³ , calendar quarter>	(a) Increased body burden; (b) Impairment of blood formation and nerve conduction
Visibility-Reducing Particles	In sufficient amount to give an extinction coefficient >0.23 inverse kilometers (visual range to less than 10 miles) with relative humidity less than 70%, 8-hour average (10am – 6pm PST)		Nephelometry and AISI Tape Sampler; instrumental measurement on days when relative humidity is less than 70 percent

**TABLE 3-2
BAY AREA AIR POLLUTION SUMMARY - 2006**

MONITORING STATIONS	OZONE						CARBON MONOXIDE			NITROGEN DIOXIDE			SULFUR DIOXIDE			PM 10				PM 2.5				
	Max 1-hr	Cal Days	Max 8-hr	Nat Days	Cal Days	3-Yr Avg	Max 1-hr	Max 8-hr	Nat/ Cal Days	Max 24-hr	Ann Avg	Nat/ Cal Days	Max 24-hr	Ann Avg	Nat/ Cal Days	Ann Avg	Max 24-hr	Nat Days	Cal Days	Max 24-hr	Nat Days	3-Yr Avg	Ann Avg	3-Yr Avg
North Counties	(ppb)						(ppm)			(ppb)			(μm^3)				(μm^3)							
Napa	96	1	72	0	2	60	3.5	2.8	0	3.5	11	0	-	-	-	21.9	52	0	1	-	-	-	-	-
San Rafael	89	0	58	0	0	50	2.6	1.5	0	2.6	14	0	-	-	-	18.1	68	0	1	-	-	-	-	-
Santa Rosa	77	0	58	0	0	47	2.4	1.7	0	2.4	11	0	-	-	-	18.8	90	0	2	59.0	1	28.7	9.2	8.3
Vallejo	80	0	69	0	0	57	3.7	2.9	0	3.7	12	0	4	1.0	0	19.8	50	0	0	42.2	1	35.6	9.8	10.2
Coast/Central Bay																								
Richmond	-	-	-	-	-	-	-	-	-	-	-	-	6	1.6	0	-	-	-	-	-	-	-	-	-
San Francisco	53	0	46	0	0	45	2.7	2.1	0	107	16	0	6	1.3	0	22.9	61	0	3	54.3	3	30.9	9.7	9.7
San Pablo	61	0	50	0	0	48	2.5	1.4	0	55	13	0	5	1.6	0	21.3	62	0	2	-	-	-	-	-
Eastern District																								
Bethel Island	116	9	90	1	14	73	1.3	1.0	0	44	8	0	7	2.1	0	19.4	84	0	1	-	-	-	-	-
Concord	117	8	92	4	14	74	1.7	1.3	0	47	11	0	7	0.8	0	18.5	81	0	3	62.1	5	35.0	9.3	9.7
Crockett	-	-	-	-	-	-	-	-	-	-	-	-	8	1.8	0	-	-	-	-	-	-	-	-	-
Fairfield	106	3	87	1	8	69	-	-	-	-	-	-	-	-	-	-	-	-	-	-	-	-	-	-
Livermore	127	13	101	5	15	80	3.3	1.8	0	64	14	0	-	-	-	21.8	69	0	3	50.8	3	33.5	9.8	9.7
Martinez	-	-	-	-	-	-	-	-	-	-	-	-	7	1.9	0	-	-	-	-	-	-	-	-	-
Pittsburg	105	3	93	1	10	70	3.3	1.9	0	52	11	0	9	2.4	0	19.9	59	0	2	-	-	-	-	-
South Central Bay																								
Fremont	102	4	74	0	3	60	2.9	1.8	0	63	15	0	-	-	-	20.0	57	0	1	43.9	2	30.3	10.3	9.6
Hayward	101	2	71	0	1	n/a	-	-	-	-	-	-	-	-	-	-	-	-	-	-	-	-	-	-
Redwood City	85	0	63	0	0	53	5.5	2.4	0	69	14	0	-	-	-	19.8	70	0	2	75.3	1	29.4	9.6	9.2
San Leandro	88	0	66	0	0	53	-	-	-	-	-	-	-	-	-	-	-	-	-	-	-	-	-	-
Santa Clara Valley																								
Gilroy	120	4	101	2	8	70	-	-	-	-	-	-	-	-	-	-	-	-	-	-	-	-	-	-
Los Gatos	116	7	87	4	11	73	-	-	-	-	-	-	-	-	-	-	-	-	-	-	-	-	-	-
San Jose Central	118	5	87	1	5	63	4.1	2.9	0	74	18	0	-	-	-	21.0	73	0	2	64.4	6	38.5	10.8	11.4
San Jose, Tully Rd	-	-	-	-	-	-	-	-	-	-	-	-	-	-	-	35.0	106	0	13	30.6	0	-	-	-
San Martin	123	7	105	5	11	76	-	-	-	-	-	-	-	-	-	-	-	-	-	-	-	-	-	-
Sunnyvale	106	3	78	0	1	63	-	-	-	-	-	-	-	-	-	-	-	-	-	-	-	-	-	-
Total Days over Standard		18		12	22				0			0			0			0	15		10			

(ppm) = parts per million, ($\mu\text{g}/\text{m}^3$) =micrograms per cubic meter, (ppb) = parts per billion

3-10

TABLE 3-3
BAY AREA AIR QUALITY SUMMARY
Days over standards

YEAR	OZONE			CARBON MONOXIDE				NO _x	SULFUR DIOXIDE		PM10		PM2.5
	1-Hr		8-Hr	1-Hr		8-Hr		1-Hr	24-Hr		24-Hr*		24-Hr**
	Nat	Cal	Nat	Nat	Cal	Nat	Cal	Cal	Nat	Cal	Nat	Cal	Nat
1996	8	34	-	0	0	0	0	0	0	0	0	3	-
1997	0	8	-	0	0	0	0	0	0	0	0	4	-
1998	8	29	16	0	0	0	0	0	0	0	0	5	-
1999	3	2	9	0	0	0	0	0	0	0	0	12	-
2000	3	12	4	0	0	0	0	0	0	0	0	7	1
2001	1	15	7	0	0	0	0	0	0	0	0	10	5
2002	2	16	7	0	0	0	0	0	0	0	0	6	5
2003	1	19	7	0	0	0	0	0	0	0	0	6	0
2004	0	7	0	0	0	0	0	0	0	0	0	7	1
2005	0	9	1	0	0	0	0	0	0	0	0	6	0
2006	18	12	0	0	0	0	0	0	0	0	0	15	15

* PM10 is sampled every sixth day – actual days over standard can be estimated to be six times the numbers listed.

** 2000 is the first full year for which the Air District measured PM2.5 levels.

Toxic Air Pollutants

The BAAQMD maintains a network of monitoring stations to monitor certain toxic air contaminants (TACs) in ambient air. In addition, the California Air Resources Board (CARB) maintains several monitoring stations in the Bay Area as part of a statewide toxics monitoring effort. Table 3-4 shows the maximum, minimum and mean concentration of toxic air contaminants at 22 of the 23 separate sites at which samples were collected. Data from the Fort Cronkhite “clean-air” background site were not included.

TABLE 3-4
SUMMARY OF BAY AREA AMBIENT AIR TOXIC AIR CONTAMINANT MONITORING DATA - 2002¹

COMPOUND	Level of Detection (ppb)	% of Samples < LOD	Maximum Conc. (ppf)	Minimum Conc. (ppb)	Mean Conc. (ppb)
Benzene	0.10	0	2.20	<0.10	0.47
Carbon Tetrachloride (CCl4)	0.01	0	0.36	<0.01	0.11
Chloroform (CHCl3)	0.02	65	0.12	<0.02	0.02
Methylene Chloride (DCM)	0.50	85	8.70	<0.50	0.38
Ethylene Dibromide	0.02	100	<0.02	<0.02	0.01
Ethylene Dichloride	0.10	100	<0.10	<0.10	0.05
Methyl Tert-Butyl Ether (MTBE)	0.50	44	4.60	<0.50	0.75
Perchloroethylene	0.01	24	0.30	<0.01	0.05
1,1,1-Trichloroethane (TCA)	0.05	47	2.69	<0.05	0.11
Trichloroethylene	0.08	96	0.84	<0.08	0.04
Toluene	0.10	0	24.9	0.10	1.48
Vinyl Chloride	0.30	100	<0.30	<0.30	0.15

(1) BAAQMD, Toxic Air Contaminant, 2002 Annual Report, June 2004.

Regulatory Background

Criteria Pollutants

At the federal level, the Clean Air Act (CAA) Amendments of 1990 give the U.S. EPA additional authority to require states to reduce emissions of ozone precursors and particulate matter in non-attainment areas. The amendments set attainment deadlines based on the severity of problems. At the state level, CARB has traditionally established state ambient air quality standards, maintained oversight authority in air quality planning, developed programs for reducing emissions from motor vehicles, developed air emission inventories, collected air quality and meteorological data, and approved state implementation plans. At a local level, California’s air districts, including the BAAQMD, are responsible for overseeing stationary source emissions, approving permits, maintaining emission inventories, maintaining air quality stations,

overseeing agricultural burning permits, and reviewing air quality-related sections of environmental documents required by CEQA.

The BAAQMD is governed by a 22-member Board of Directors composed of publicly-elected officials apportioned according to the population of the represented counties. The Board has the authority to develop and enforce regulations for the control of air pollution within its jurisdiction. The BAAQMD is responsible for implementing emissions standards and other requirements of federal and state laws. It is also responsible for developing air quality planning documents required by both federal and state laws.

Toxic Air Contaminants

TACs are regulated in the District through federal, state, and local programs. At the federal level, TACs are regulated primarily under the authority of the CAA. Prior to the amendment of the CAA in 1990, source-specific National Emission Standards for Hazardous Air Pollutants (NESHAPs) were promulgated under Section 112 of the CAA for certain sources of radionuclides and Hazardous Air Pollutants (HAPs).

Title III of the 1990 CAA amendments requires U.S. EPA to promulgate NESHAPs on a specified schedule for certain categories of sources identified by U.S. EPA as emitting one or more of the 189 listed HAPs. Emission standards for major sources must require the maximum achievable control technology (MACT). MACT is defined as the maximum degree of emission reduction achievable considering cost and non-air quality health and environmental impacts and energy requirements. All NESHAPs were to be promulgated by the year 2000. Specific incremental progress in establishing standards must be made by the years 1992 (at least 40 source categories), 1994 (25 percent of the listed categories), 1997 (50 percent of remaining listed categories), and 2000 (remaining balance). The 1992 requirement was met; however, many of the four-year standards were not promulgated as scheduled. Promulgation of those standards has been rescheduled based on court ordered deadlines, or the aim to satisfy all Section 112 requirements in a timely manner.

Many of the sources of TACs that have been identified under the CAA are also subject to the California TAC regulatory programs. CARB developed three regulatory programs for the control of TACs. Each of the programs is discussed in the following subsections.

Control of TACs Under the TAC Identification and Control Program: California's TAC identification and control program, adopted in 1983 as Assembly Bill 1807 (AB 1807) (California Health and Safety Code §39662), is a two-step program in which substances are identified as TACs, and airborne toxic control measures (ATCMs) are adopted to control emissions from specific sources. Since adoption of the program, CARB has identified 18 TACs, and CARB adopted a regulation designating all 189 federal HAPs as TACs.

Control of TACs Under the Air Toxics "Hot Spots" Act: The Air Toxics Hot Spot Information and Assessment Act of 1987 (AB 2588) (California Health and Safety Code §39656) establishes a state-wide program to inventory and assess the risks from facilities that emit TACs and to notify the public about significant health risks associated with those emissions. Inventory reports must be updated every four years under current state law. The BAAQMD uses a maximum individual cancer risk of 10 in one million, or an ambient concentration above a non-cancer reference exposure level, as the threshold for notification.

Senate Bill (SB) 1731, enacted in 1992 (California Health and Safety Code §44390 et seq.), amended AB 2588 to include a requirement for facilities with significant risks to prepare and implement a risk reduction

plan which will reduce the risk below a defined significant risk level within specified time limits. At a minimum, such facilities must, as quickly as feasible, reduce cancer risk levels that exceed 100 per one million. The BAAQMD adopted risk reduction requirements for perchloroethylene dry cleaners to fulfill the requirements of SB 1731.

Targeted Control of TACs Under the Community Air Risk Evaluation Program: In 2004, BAAQMD established the Community Air Risk Evaluation (CARE) program to identify locations with high emissions of toxic air contaminants (TAC) and high exposures of sensitive populations to TAC and to use this information to help establish policies to guide mitigation strategies that obtain the greatest health benefit from TAC emission reductions. For example, BAAQMD will use information derived from the CARE program to develop and implement targeted risk reduction programs, including grant and incentive programs, community outreach efforts, collaboration with other governmental agencies, model ordinances, new regulations for stationary sources and indirect sources, and advocacy for additional legislation.

Discussion of Impacts

III a. The objective of the proposed Rule 6-2 is to reduce PM and VOC emissions from commercial cooking equipment in order to reduce particulate matter and ozone levels in the Bay Area. The District is proposing Regulation 6, Rule 2, in accordance with the District's SB 656 Particulate Matter Implementation Schedule and in connection with FS 3 in the District's 2005 Ozone Strategy, as a means to reduce restaurant emissions of PM and VOCs in the Bay Area. Therefore, the proposed regulation is in compliance with and will implement a portion of local air quality strategies. No significant adverse impacts are expected.

III b, c, d, and f. The District is proposing Regulation 6, Rule 2, in accordance with the District's SB 656 Particulate Matter Implementation Schedule and in connection with FS 3 in the District's 2005 Ozone Strategy, as a means to reduce restaurant emissions of PM and VOCs in the Bay Area. VOCs are ozone precursors, and also contribute to indirect or secondary PM. SB 656 requires that all air districts in California adopt an implementation schedule that prioritizes appropriate measures for reducing PM emissions. The District's Particulate Matter Implementation Schedule proposes to adopt Regulation 6, Rule 2 as a measure to reduce direct and indirect PM emissions in the Bay Area. Implementation of proposed Regulation 6, Rule 2 would require catalytic oxidizers to be installed on high-emitting chain-driven (conveyorized) charbroilers, but allow alternative certified controls to be installed if the control can reduce emissions to no more than 0.74 lbs of PM10 and 0.23 lbs of organic compounds per 1,000 lbs of meat cooked (effective PM10 reduction of 90 percent). The catalytic oxidizers are expected to be fitted to the top of a chain-driven charbroiler, where it will burn grease and gases from the cooking process, turning them into carbon dioxide and water. Heat from the cooking process activates the device such that an external fuel source is not required. Regulation 6, Rule 2 would also require controls on the highest emitting restaurants with under-fired charbroilers, restaurants that purchase 1000 lbs of beef per week and grill at least 800 lbs of beef. Controls for under-fired charbroilers are more likely to be mounted in the exhaust ventilation on the restaurant roof, and are expected to be electrostatic precipitators (ESPs) or HEPA filters. Based on the air quality analysis, proposed Rule 6-2 is expected to result in reductions in PM and VOC emissions and, thus, provide air quality benefits. No significant adverse impacts to air quality are expected.

III e. Proposed Rule 6-2 requires a reduction PM and VOC emissions from some commercial cooking equipment. Facilities are expected to comply with the required installation of control devices. Once

installed, the control devices are not expected to result in any physical changes to the facilities and would not be expected to generate any additional odors. Catalytic oxidizers installed to control emissions from conveyORIZED charbroilers will reduce odors and controls on under-fired charbroilers will also reduce odors to some extent. The rule is not expected to generate any additional odors at the affected facilities.

	Potentially Significant Impact	Less Than Significant Impact With Mitigation Incorporated	Less Than Significant Impact	No Impact
--	--------------------------------	---	------------------------------	-----------

IV. BIOLOGICAL RESOURCES. Would the project:

- | | | | | |
|--|--------------------------|--------------------------|--------------------------|-------------------------------------|
| a) Have a substantial adverse effect, either directly or through habitat modifications, on any species identified as a candidate, sensitive, or special status species in local or regional plans, policies, or regulations, or by the California Department of Fish and Game or U.S. Fish and Wildlife Service? | <input type="checkbox"/> | <input type="checkbox"/> | <input type="checkbox"/> | <input checked="" type="checkbox"/> |
| b) Have a substantial adverse effect on any riparian habitat or other sensitive natural community identified in local or regional plans, policies, or regulations, or by the California Department of Fish and Game or U.S. Fish and Wildlife Service? | <input type="checkbox"/> | <input type="checkbox"/> | <input type="checkbox"/> | <input checked="" type="checkbox"/> |
| c) Have a substantial adverse effect on federally protected wetlands as defined by Section 404 of the Clean Water Act (including, but not limited to, marsh, vernal pool, coastal wetlands, etc.) through direct removal, filling, hydrological interruption, or other means? | <input type="checkbox"/> | <input type="checkbox"/> | <input type="checkbox"/> | <input checked="" type="checkbox"/> |
| d) Interfere substantially with the movement of any native resident or migratory fish or wildlife species or with established native resident or migratory wildlife corridors, or impede the use of native wildlife nursery sites? | <input type="checkbox"/> | <input type="checkbox"/> | <input type="checkbox"/> | <input checked="" type="checkbox"/> |
| e) Conflicting with any local policies or ordinances protecting biological resources, such as a tree preservation policy or ordinance? | <input type="checkbox"/> | <input type="checkbox"/> | <input type="checkbox"/> | <input checked="" type="checkbox"/> |
| f) Conflict with the provisions of an adopted habitat conservation plan, natural community conservation plan, or other approved local, regional, or state habitat conservation plan? | <input type="checkbox"/> | <input type="checkbox"/> | <input type="checkbox"/> | <input checked="" type="checkbox"/> |

Setting

The BAAQMD covers all of Alameda, Contra Costa, Marin, San Francisco, San Mateo, Santa Clara, and Napa Counties and portions of southwestern Solano and southern Sonoma Counties. The area of coverage is vast (about 5,600 square miles) so that land uses vary greatly and include commercial, industrial, residential, agricultural, and open space uses. A wide variety of biological resources are located within the Bay Area.

The facilities affected by the proposed rule are located in the Bay Area-Delta Bioregion (as defined by the State's Natural Communities Conservation Program). This Bioregion is comprised of a variety of natural communities, which range from salt marshes to chaparral to oak woodland. The facilities affected by the proposed rule are located in commercial areas throughout the Bay Area. The affected facilities have been graded to develop the various commercial structures and are typically, surrounded by other commercial facilities. Native vegetation, other than landscape vegetation, has generally been removed from operating portions of the commercial facilities to minimize safety and fire hazards.

Regulatory Background

Biological resources are generally protected by the City and/or County General Plans through land use and zoning requirements which minimize or prohibit development in biologically sensitive areas. Biological resources are also protected by the California Department of Fish and Game, and the U.S. Fish and Wildlife Service. The U.S. Fish and Wildlife Service and National Marine Fisheries Service oversee the federal Endangered Species Act. Development permits may be required from one or both of these agencies if development would impact rare or endangered species. The California Department of Fish and Game administers the California Endangered Species Act which prohibits impacting endangered and threatened species. The U.S. Army Corps of Engineers and the U.S. EPA regulate the discharge of dredge or fill material into waters of the United States, including wetlands.

Discussion of Impacts

IV a – f. No impacts on biological resources are anticipated from the proposed rule which would apply to existing and new facilities with commercial cooking equipment. The restaurants are located within the confines of commercial facilities. The net effect of implementing proposed Rule 6-2 will be improved air quality resulting from reduction of restaurant emissions which is expected to be beneficial for both plant and animal life. Installation of control devices would not result in any physical changes outside of the confines of the existing commercial cooking facilities and would not affect any biological resources in the area. Therefore, no adverse significant impacts to biological resources are expected due to the proposed project.

	Potentially Significant Impact	Less Than Significant Impact With Mitigation Incorporated	Less Than Significant Impact	No Impact
V. CULTURAL RESOURCES. Would the project:				
a) Cause a substantial adverse change in the significance of a historical resource as defined in Section 15064.5?	<input type="checkbox"/>	<input type="checkbox"/>	<input type="checkbox"/>	<input checked="" type="checkbox"/>
b) Cause a substantial adverse change in the significance of an archaeological resource pursuant to Section 15064.5?	<input type="checkbox"/>	<input type="checkbox"/>	<input type="checkbox"/>	<input checked="" type="checkbox"/>
c) Directly or indirectly destroy a unique paleontological resource or site or unique geologic feature?	<input type="checkbox"/>	<input type="checkbox"/>	<input type="checkbox"/>	<input checked="" type="checkbox"/>
d) Disturb any human remains, including those interred outside formal cemeteries?	<input type="checkbox"/>	<input type="checkbox"/>	<input type="checkbox"/>	<input checked="" type="checkbox"/>

Setting

The BAAQMD covers all of Alameda, Contra Costa, Marin, San Francisco, San Mateo, Santa Clara, and Napa Counties and portions of southwestern Solano and southern Sonoma Counties. The area of coverage is vast (about 5,600 square miles) so that land uses vary greatly and include commercial, industrial, residential, agricultural and open space uses. Cultural resources are defined as buildings, sites, structures, or objects which might have historical architectural, archaeological, cultural, or scientific importance.

The Carquinez Strait represents the entry point for the Sacramento and San Joaquin Rivers into the San Francisco Bay. This locality lies within the San Francisco Bay and the west end of the Central Valley archaeological regions, both of which contain a rich array of prehistoric and historical cultural resources. The areas surrounding the Carquinez Strait and Suisun Bay have been occupied for millennia given their abundant combination of littoral and oak woodland resources.

The facilities with commercial cooking equipment affected by the proposed rule generally are located in commercial areas throughout the Bay Area. The sites have been graded to develop the various commercial structures and are typically surrounded by other commercial and industrial facilities. Cultural resources are generally not located within the operating portions of commercial facilities.

Regulatory Background

The State CEQA Guidelines define a significant cultural resource as a “resource listed or eligible for listing on the California Register of Historical Resources” (Public Resources Code Section 5024.1). A project would have a significant impact if it would cause a substantial adverse change in the significance of a historical resource (State CEQA Guidelines Section 15064.5(b)). A substantial adverse change in the significance of a historical resource would result from an action that would demolish or adversely alter the physical characteristics of the historical resource that convey its historical significance and that qualify the resource for inclusion in the California Register of Historical Resources or a local register or survey that meets the requirements of Public Resources Code Sections 50020.1(k) and 5024.1(g).

Discussion of Impacts

V a – d. No impacts on cultural resources are anticipated from the proposed rule that would apply to existing facilities with commercial cooking equipment. The equipment already exists and is located within the confines of existing facilities. Catalytic oxidizers are expected to be fitted to the top of a chain-driven charbroilers, and therefore, would not result in any physical changes outside of the confines of the existing commercial cooking facilities. Also, although buildings that are considered cultural resources may have restaurants, it is unlikely that the restaurants would be fitted with conveyorized charbroilers or under-fired charbroilers large enough to trigger the requirements in the rule. If restaurants did have a charbroiler subject to the proposed rule, alternative lower-emitting cooking equipment could be used in lieu of installation of a control device. Therefore, no adverse significant impacts to cultural resources are expected due to the proposed project.

	Potentially Significant Impact	Less Than Significant Impact With Mitigation Incorporated	Less Than Significant Impact	No Impact
--	--------------------------------	---	------------------------------	-----------

VI. GEOLOGY AND SOILS.

Would the project:

- | | | | | |
|---|--------------------------|--------------------------|--------------------------|-------------------------------------|
| a) Expose people or structures to potential substantial adverse effects, including the risk of loss, injury, or death involving: | <input type="checkbox"/> | <input type="checkbox"/> | <input type="checkbox"/> | <input checked="" type="checkbox"/> |
| • Rupture of a known earthquake fault, as delineated on the most recent Alquist-Priolo Earthquake Fault Zoning Map issued by the State Geologist for the area or based on other substantial evidence of a known fault? Refer to Division of Mines and Geology Special Publication 42. | <input type="checkbox"/> | <input type="checkbox"/> | <input type="checkbox"/> | <input checked="" type="checkbox"/> |
| • Strong seismic ground shaking? | <input type="checkbox"/> | <input type="checkbox"/> | <input type="checkbox"/> | <input checked="" type="checkbox"/> |
| • Seismic-related ground failure, including liquefaction? | <input type="checkbox"/> | <input type="checkbox"/> | <input type="checkbox"/> | <input checked="" type="checkbox"/> |

- Landslides?
- b) Result in substantial soil erosion or the loss of topsoil?
- c) Be located on a geologic unit or soil that is unstable or that would become unstable as a result of the project, and potentially result in onsite or offsite landslide, lateral spreading, subsidence, liquefaction or collapse?
- d) Be located on expansive soil, as defined in Table 18-1-B of the Uniform Building Code (1994), creating substantial risks to life or property?
- e) Have soils incapable of adequately supporting the use of septic tanks or alternative wastewater disposal systems in areas where sewers are not available for the disposal of wastewater?

Setting

The BAAQMD covers all of Alameda, Contra Costa, Marin, San Francisco, San Mateo, Santa Clara, and Napa Counties and portions of southwestern Solano and southern Sonoma Counties. The area of coverage is vast (about 5,600 square miles) so that land uses vary greatly and include commercial, industrial, residential, agricultural, and open space uses. The facilities affected by the proposed rule are located in the commercial areas throughout the Bay Area.

The affected facilities with commercial cooking equipment are located in the natural region of California known as the Coast Ranges geomorphic province. The province is characterized by a series of northwest trending ridges and valleys controlled by tectonic folding and faulting, examples of which include the Suisun Bay, East Bay Hills, Briones Hills, Vaca Mountains, Napa Valley, and Diablo Ranges.

Regional basement rocks consist of the highly deformed Great Valley Sequence, which include massive beds of sandstone inter-fingered with siltstone and shale. Unconsolidated alluvial deposits, artificial fill, and estuarine deposits, (including Bay Mud) underlie the low-lying region along the margins of the Carquinez Straight and Suisun Bay. The estuarine sediments found along the shorelines of Solano County are soft, water-saturated mud, peat and loose sands. The organic, soft, clay-rich sediments along the San Francisco and San Pablo Bays are referred to locally as Bay Mud and can present a variety of engineering challenges due to inherent low strength, compressibility and saturated conditions. Landslides in the region occur in weak, easily weathered bedrock on relatively steep slopes.

The San Francisco Bay Area is a seismically active region, which is situated on a plate boundary marked by the San Andreas Fault System. Several northwest trending active and potentially active faults are included with this fault system. Under the Alquist-Priolo Earthquake Fault Zoning Act, Earthquake Fault Zones were established by the California Division of Mines and Geology along “active” faults, or faults along which surface rupture occurred in Holocene time (the last 11,000 years). In the Bay area, these faults include the

San Andreas, Hayward, Rodgers Creek-Healdsburg, Concord-Green Valley, Greenville-Marsh Creek, Seal Cove/San Gregorio and West Napa faults. Other smaller faults in the region classified as potentially active include the Southampton and Franklin faults.

Ground movement intensity during an earthquake can vary depending on the overall magnitude, distance to the fault, focus of earthquake energy, and type of geological material. Areas that are underlain by bedrock tend to experience less ground shaking than those underlain by unconsolidated sediments such as artificial fill. Earthquake ground shaking may have secondary effects on certain foundation materials, including liquefaction, seismically induced settlement, and lateral spreading.

Regulatory Background

Construction is regulated by the local City or County building codes that provide requirements for construction, grading, excavations, use of fill, and foundation work including type of materials, design, procedures, etc. which are intended to limit the probability of occurrence and the severity of consequences from geological hazards. Necessary permits, plan checks, and inspections are generally required.

The City or County General Plan includes the Seismic Safety Element. The Element serves primarily to identify seismic hazards and their location in order that they may be taken into account in the planning of future development. The Uniform Building Code is the principle mechanism for protection against and relief from the danger of earthquakes and related events.

In addition, the Seismic Hazard Zone Mapping Act (Public Resources Code §§2690 – 2699.6) was passed by the California legislature in 1990 following the Loma Prieta earthquake. The Act required that the California Division of Mines and Geology (DMG) develop maps that identify the areas of the state that require site specific investigation for earthquake-triggered landslides and/or potential liquefaction prior to permitting most urban developments. The act directs cities, counties and state agencies to use the maps in their land use planning and permitting processes.

Local governments are responsible for implementing the requirements of the Seismic Hazards Mapping Act. The maps and guidelines are tools for local governments to use in establishing their land use management policies and in developing ordinances and review procedures that will reduce losses from ground failure during future earthquakes.

Discussion of Impacts

VI a. No impacts on geology and soils are anticipated from the proposed rule that would apply to existing operations at affected facilities. The cooking equipment already exists and is located within the confines of existing facilities. Catalytic oxidizers are expected to be fitted to the top of a chain-driven charbroiler. Installation of HEPA filters or electrostatic precipitators to control under-fired charbroilers would occur in existing exhaust ducting. In some cases, restaurant roof supports may need to be strengthened to accommodate the new equipment, however, alternative lower-emitting cooking equipment could be used that would not be subject to the rule's requirements.. New control equipment may require building permits from the local jurisdiction and compliance with the Uniform Building Codes. The Uniform Building Code is considered to be a standard safeguard against major structural failures and loss of life. The goal of the code

is to provide structures that will: (1) resist minor earthquakes without damage; (2) resist moderate earthquakes without structural damage, but with some non-structural damage; and (3) resist major earthquakes without collapse, but with some structural and non-structural damage. The Uniform Building Code bases seismic design on minimum lateral seismic forces ("ground shaking"). The Uniform Building Code requirements operate on the principle that providing appropriate foundations, among other aspects, helps to protect buildings from failure during earthquakes. The basic formulas used for the Uniform Building Code seismic design require determination of the seismic zone and site coefficient, which represent the foundation conditions at the site.

The new control equipment may be required to obtain building permits, if applicable. The issuance of building permits from the local agency will assure compliance with the Uniform Building Code requirements which include requirements for building within seismic hazard zones. No significant impacts from seismic hazards are expected since the project will be required to comply with the Uniform Building Codes. Therefore no people or structures are expected to be exposed to potential substantial adverse effects, including the risk of loss, injury, or death due to rupture of a known earthquake fault, strong seismic ground shaking or seismic-related ground failure, including liquefaction landslides. Therefore, no adverse significant impacts related to seismic activity are expected due to the proposed rule.

VII b – e. No impacts on geology and soils are anticipated from the proposed rule that would apply to existing operations at affected facilities. Installation of catalytic oxidizers or equivalent control devices on chain-driven charboilers would not result in any physical changes to the facilities. Installation of control equipment for under-fired charbroilers would occur on existing roofs. Therefore, construction activities associated with the proposed rule is not expected to result in substantial soil erosion or the loss of topsoil. The facilities already exist and no construction activities outside the confines of the existing commercial cooking facilities are expected. Likewise, no new structure is expected to be constructed on expansive soil, as defined in Table 18-1-B of the Uniform Building Code (1994), creating substantial risks to life or property. Construction would not affect soils incapable of adequately supporting the use of septic tanks or alternative wastewater disposal systems in areas where sewers are not available for the disposal of wastewater. Therefore, no adverse significant impacts to geology and soils are expected due to the proposed rule.

	Potentially Significant Impact	Less Than Significant Impact With Mitigation Incorporated	Less Than Significant Impact	No Impact
--	--------------------------------------	---	------------------------------------	-----------

VII. HAZARDS AND HAZARDOUS MATERIALS. Would the project:

- a) Create a significant hazard to the public or the environment through the routine transport, use, or disposal of hazardous materials?

- b) Create a significant hazard to the public or the environment through reasonably foreseeable upset and accident conditions involving the release of hazardous materials into the environment?

- | | | | | | |
|----|---|--------------------------|--------------------------|--------------------------|-------------------------------------|
| c) | Emit hazardous emissions or involve handling hazardous or acutely hazardous materials, substances, or waste within one-quarter mile of an existing or proposed school? | <input type="checkbox"/> | <input type="checkbox"/> | <input type="checkbox"/> | <input checked="" type="checkbox"/> |
| d) | Be located on a site that is included on a list of hazardous materials sites compiled pursuant to Government Code Section 65962.5 and, as a result, would it create a significant hazard to the public or the environment? | <input type="checkbox"/> | <input type="checkbox"/> | <input type="checkbox"/> | <input checked="" type="checkbox"/> |
| e) | Be located within an airport land use plan or, where such a plan has not been adopted, be within two miles of a public airport or public use airport, and result in a safety hazard for people residing or working in the project area? | <input type="checkbox"/> | <input type="checkbox"/> | <input type="checkbox"/> | <input checked="" type="checkbox"/> |
| f) | Be located within the vicinity of a private airstrip and result in a safety hazard for people residing or working in the project area? | <input type="checkbox"/> | <input type="checkbox"/> | <input type="checkbox"/> | <input checked="" type="checkbox"/> |
| g) | Impair implementation of or physically interfere with an adopted emergency response plan or emergency evacuation plan? | <input type="checkbox"/> | <input type="checkbox"/> | <input type="checkbox"/> | <input checked="" type="checkbox"/> |
| h) | Expose people or structures to a significant risk of loss, injury or death involving wild land fires, including where wild lands are adjacent to urbanized areas or where residences are intermixed with wild lands? | <input type="checkbox"/> | <input type="checkbox"/> | <input type="checkbox"/> | <input checked="" type="checkbox"/> |

Setting

The risks posed by operations at each facility are unique and determined by a variety of factors. The facilities affected by the proposed amendments tend to be located in commercial areas. For all affected facilities, risks to the public are reduced if there is a buffer zone between industrial processes and residences or other sensitive land uses, or the prevailing wind blows away from residential areas and other sensitive land uses. The hazards associated with commercial cooking operations are generated limited to fire hazards associated with cooking activities.

Regulatory Background

There are many federal and state rules and regulations that affected facilities must comply with which serve to minimize the potential impacts associated with hazards at these facilities.

Under the Occupational Safety and Health Administration (OSHA) regulations [29 Code of Federal Regulations (CFR) Part 1910], facilities which use, store, manufacture, handle, process, or move highly

hazardous materials must prepare a fire prevention plan. In addition, 29 CFR Part 1910.119, Process Safety Management (PSM) of Highly Hazardous Chemicals, and Title 8 of the California Code of Regulations, General Industry Safety Order §5189, specify required prevention program elements to protect workers at facilities that handle toxic, flammable, reactive, or explosive materials. Prevention program elements are aimed at preventing or minimizing the consequences of catastrophic releases of the chemicals and include process hazard analyses, formal training programs for employees and contractors, investigation of equipment mechanical integrity, and an emergency response plan.

Section 112 (r) of the Clean Air Act Amendments of 1990 [42 U.S.C. 7401 et. Seq.] and Article 2, Chapter 6.95 of the California Health and Safety Code require facilities that handle listed regulated substances to develop Risk Management Programs (RMPs) to prevent accidental releases of these substances, U.S. EPA regulations are set forth in 40 CFR Part 68. In California, the California Accidental Release Prevention (CalARP) Program regulation (CCR Title 19, Division 2, Chapter 4.5) was issued by the Governor's Office of Emergency Services (OES). RMPs consist of three main elements: a hazard assessment that includes off-site consequences analyses and a five-year accident history, a prevention program, and an emergency response program. Refineries are also required to comply with the U.S. EPA's Emergency Planning and Community Right-to-Know Act (EPCRA).

California Assembly Bill 2185 requires local agencies to regulate the storage and handling of hazardous materials and requires development of a plan to mitigate the release of hazardous materials. Businesses that handle any of the specified hazardous materials must submit to government agencies (i.e., fire departments), an inventory of the hazardous materials, an emergency response plan, and an employee training program. The business plans must provide a description of the types of hazardous materials/waste on-site and the location of these materials. The information in the business plan can then be used in the event of an emergency to determine the appropriate response action, the need for public notification, and the need for evacuation.

Discussion of Impacts

VII a - c. The proposed rule is expected to reduce emissions from existing commercial cooking equipment at affected facilities thus reducing PM and VOC emissions. The rule will not require or change the use or storage of any hazardous material. The catalytic oxidizer required by the rule will not cause any hazard impacts or introduce any additional fire hazards, as it contains a catalyst bed made up of an inert ceramic material. With open flame equipment, most restaurant kitchens already have a potential for fire hazards. Installation of a catalytic oxidizer is not expected to increase fire hazards because they do not require an additional combustion source. Further, installation of the catalytic oxidizer is expected to reduce natural gas usage by up to seven percent, thus slightly reducing existing fire hazards. Cleaning the catalyst does not generate hazardous wastewater effluent and is not expected to create additional health hazards or result in exposing people to existing sources of potential health hazards. Similarly, cleaning electrostatic precipitator plates does not generate hazardous wastewater effluent and is not expected to create additional health hazards. Therefore, no significant adverse impacts on releases of hazardous materials into the environment are expected.

VII d. No impacts on hazardous material sites are anticipated from the proposed rule that would apply to existing commercial cooking operations. The proposed rule would have no affect on hazardous materials nor would the rule create a significant hazard to the public or environment. The cooking equipment already

exists and is located within the confines of existing commercial facilities. The proposed rule neither requires, nor is likely to result in, activities that would affect hazardous materials or existing site contamination. Therefore, no significant adverse impacts on hazards are expected.

VII e – f. No impacts on airports or airport land use plans are anticipated from the proposed rule, which would apply to operations at existing facilities. The cooking equipment already exists and is located within the confines of existing facilities. Installation of catalytic oxidizers or equivalent control devices on chain-driven charbroilers would not result in any physical changes to the facilities and would not affect the environment outside of affected facilities. Therefore, no significant adverse impacts on hazards at airports are expected.

VII g. No impacts on emergency response plans are anticipated from the proposed rule that would apply to existing facility operations. Installation of catalytic oxidizers or equivalent control devices on chain-driven charbroilers and is not expected to result in any changes to emergency response plans. Therefore, no significant adverse impacts on emergency response plans are expected.

VII h. No increase in hazards related to wildfires is anticipated from implementation of the proposed rule. The cooking equipment already exists and is located within the confines of existing facilities. Installation of catalytic oxidizers or equivalent control devices on chain-driven charbroilers is not expected to result in any physical changes that would increase wildfire hazards. Vegetation surrounding commercial facilities has generally been removed, with the exception of landscape vegetation. Therefore, no significant adverse impacts on fire hazards are expected.

	Potentially Significant Impact	Less Than Significant Impact With Mitigation Incorporated	Less Than Significant Impact	No Impact
--	--------------------------------	---	------------------------------	-----------

VIII. HYDROLOGY AND WATER QUALITY.

Would the project:

- | | | | | | |
|----|--|--------------------------|--------------------------|-------------------------------------|-------------------------------------|
| a) | Violate any water quality standards or waste discharge requirements? | <input type="checkbox"/> | <input type="checkbox"/> | <input type="checkbox"/> | <input checked="" type="checkbox"/> |
| b) | Substantially deplete groundwater supplies or interfere substantially with groundwater recharge such that there would be a net deficit in aquifer volume or a lowering of the local groundwater table level (e.g. the production rate of pre-existing nearby wells would drop to a level that would not support existing land uses or planned uses for which permits have been granted)? | <input type="checkbox"/> | <input type="checkbox"/> | <input checked="" type="checkbox"/> | <input type="checkbox"/> |
| c) | Substantially alter the existing drainage pattern of the site or area, including through alteration of the course of a stream or river, in a manner that would result in substantial erosion or siltation onsite or offsite? | <input type="checkbox"/> | <input type="checkbox"/> | <input type="checkbox"/> | <input checked="" type="checkbox"/> |

- | | | | | |
|--|--------------------------|--------------------------|--------------------------|-------------------------------------|
| d) Substantially alter the existing drainage pattern of the site or area, including through alteration of the course of a stream or river, or substantially increase the rate or amount of surface runoff in a manner that would result in flooding onsite or offsite? | <input type="checkbox"/> | <input type="checkbox"/> | <input type="checkbox"/> | <input checked="" type="checkbox"/> |
| e) Create or contribute runoff water that would exceed the capacity of existing or planned storm water drainage systems or provide substantial additional sources of polluted runoff? | <input type="checkbox"/> | <input type="checkbox"/> | <input type="checkbox"/> | <input checked="" type="checkbox"/> |
| f) Otherwise substantially degrade water quality? | <input type="checkbox"/> | <input type="checkbox"/> | <input type="checkbox"/> | <input checked="" type="checkbox"/> |
| g) Place housing within a 100-year flood hazard area, as mapped on a federal Flood Hazard Boundary or Flood Insurance Rate Map or other flood hazard delineation map? | <input type="checkbox"/> | <input type="checkbox"/> | <input type="checkbox"/> | <input checked="" type="checkbox"/> |
| h) Place within a 100-year flood hazard area structures that would impede or redirect flood flows? | <input type="checkbox"/> | <input type="checkbox"/> | <input type="checkbox"/> | <input checked="" type="checkbox"/> |
| i) Expose people or structures to a significant risk of loss, injury or death involving flooding, including flooding as a result of the failure of a levee or dam? | <input type="checkbox"/> | <input type="checkbox"/> | <input type="checkbox"/> | <input checked="" type="checkbox"/> |
| j) Inundation by seiche, tsunami, or mudflow? | <input type="checkbox"/> | <input type="checkbox"/> | <input type="checkbox"/> | <input checked="" type="checkbox"/> |

Setting

The BAAQMD covers all of Alameda, Contra Costa, Marin, San Francisco, San Mateo, Santa Clara, and Napa Counties and portions of southwestern Solano and southern Sonoma Counties. The area of coverage is vast (about 5,600 square miles) so that land uses and affected environment vary substantially throughout the area and include commercial, industrial, residential, agricultural, and open space uses.

The facilities affected by the proposed rule are located in the commercial areas throughout the Bay Area. Affected facilities are generally surrounded by other commercial. Reservoirs and drainage streams are located throughout the area and discharge into the Bays. Marshlands incised with numerous winding tidal channels containing brackish water are located throughout the Bay Area.

The affected facilities are located within the San Francisco Bay Area Hydrologic Basin. The primary regional groundwater water-bearing formations include the recent and Pleistocene (up to two million years old) alluvial deposits and the Pleistocene Huichica formation. Salinity within the unconfined alluvium appears to increase with depth to at least 300 feet. Water of the Huichica formation tends to be soft and relatively high in bicarbonate, although usable for domestic and irrigation needs.

Regulatory Background

The Federal Clean Water Act of 1972 primarily establishes regulations for pollutant discharges into surface waters in order to protect and maintain the quality and integrity of the nation's waters. This Act requires industries that discharge wastewater to municipal sewer systems to meet pretreatment standards. The regulations authorize the U.S. EPA to set the pretreatment standards. The regulations also allow the local treatment plants to set more stringent wastewater discharge requirements, if necessary, to meet local conditions.

The 1987 amendments to the Clean Water Act enabled the U.S. EPA to regulate, under the National Pollutant Discharge Elimination System (NPDES) program, discharges from industries and large municipal sewer systems. The U.S. EPA set initial permit application requirements in 1990. The State of California, through the State Water Resources Control Board, has authority to issue NPDES permits, which meet U.S. EPA requirements, to specified industries.

The Porter-Cologne Water Quality Act is California's primary water quality control law. It implements the state's responsibilities under the Federal Clean Water Act but also establishes state wastewater discharge requirements. The RWQCB administers the state requirements as specified under the Porter-Cologne Water Quality Act, which include storm water discharge permits. The water quality in the Bay Area is under the jurisdiction of the San Francisco Bay Regional Water Quality Control Board.

In response to the Federal Act, the State Water Resources Control Board prepared two state-wide plans in 1991 and 1995 that address storm water runoff: the California Inland Surface Waters Plan and the California Enclosed Bays and Estuaries Plan. Enclosed bays are indentations along the coast that enclose an area of oceanic water within distinct headlands or harbor works. San Francisco Bay, and its constituent's parts, including Carquinez Strait and Suisun Bay, fall under this category.

The San Francisco Bay Basin Plan identifies the: (1) beneficial water uses that need to be protected; (2) the water quality objectives needed to protect the designated beneficial water uses; and (3) strategies and time schedules for achieving the water quality objectives. The beneficial uses of the Carquinez Strait that must be protected which include water contact and non-contact recreation, navigation, ocean commercial and sport fishing, wildlife habitat, estuarine habitat, fish spawning and migration, industrial process and service supply, and preservation of rare and endangered species. The Carquinez Strait and Suisun Bay are included on the 1998 California list as impaired water bodies due to the presence of chlordane, copper, DDT, diazinon, dieldrin, dioxin and furan compounds, mercury, nickel, PCBs, and selenium.

Discussion of Impacts

VIII a. No significant adverse impacts on hydrology/water quality resources are anticipated from implementation of the proposed rule, which would apply to existing commercial facilities. Owners/operators of facilities affected by the proposed rule would be required to install catalytic oxidizers or other control devices and to maintain the equipment in good working order to effectively reduce PM and VOC emissions. Standard maintenance procedure involves soaking the catalyst in water to remove the residue build-up. The frequency of maintenance to maintain proper working order depends upon the individual usage of the charbroiler. Frequency of clean-up (soaking in soapy water) ranges from every three to six months. This removes residue that has built-up on the catalyst bed. Due to the small size of the catalyst bed and the

frequency of the needed soaking, the amount of salt removed per cleaning is expected to be negligible. The resulting wastewater, which also may contain grease and particles, will require minimal treatment from publicly owned treatment works prior to discharge. Under-fired charbroilers that use ESPs for control may choose to install an automatic wash system. The automatic wash system is individually designed for each unit depending on the amount of meat cooked. Frequency of clean up could be as often as daily, but is more likely twice per week. As with cleaning of catalysts, wastewater would require minimal treatment from publically owned treatment works prior to discharge.

The San Francisco Public Utilities Commission (PUC) is a department of the City and County of San Francisco that provides water, wastewater, and municipal power services to San Francisco. Under contractual agreement with 29 wholesale water agencies, the SFPUC also supplies water to 1.6 million additional customers within three Bay Area counties. The San Francisco PUC treats and discharges approximately 84 million gallons per day of treated wastewater during dry weather to the San Francisco Bay and Pacific Ocean. During wet weather, with additional facilities and increased operations, the plants can treat approximately 465 million gallons of combined flows per day (www.sfwater.org). Since only a small increase in salt is expected due to cleaning activities, no violation of any water quality standards or waste discharge requirements is expected.

VIII b. The cooking equipment affected by the proposed rule already exists and are located within the confines of existing restaurants and facilities. The proposed rule does not require the installation of new large pieces of equipment or require new public services. According to current users of catalytic oxidizers, the frequency of clean-up ranges from every three to six months. If soaked once every three months in 10 gallons of soapy water, the 443 catalysts in the district would increase the district water demand by approximately 49 gallons per day (17,885 gallons per year) [(10 gallons/3 months) x (443 catalysts) x (month/30 day)]. Cleaning electrostatic precipitators would use -a variable amount of water depending on how many systems used an automatic wash system. An automatic wash system uses, on average, 240 gallons of water per cleaning. If all the under-fired broiler restaurants affected installed ESPs and half installed an auto-wash system, and washed the ESP twice per week, the total water used would be 6838 gallons per day (2,496,000 gallons per year) [(2 cleanings/week) x (100 ESPs) x (52 weeks/year)]. The use of catalytic oxidizers, electrostatic precipitators or HEPA filters, however, would tend to keep exhaust fans and downstream ductworks cleaner, requiring less water usage for periodic duct cleaning. The 2005 Ozone Strategy addressed the impacts of the proposed control measures on water demand. Although FS-3 was not part of the control strategy, the analysis did consider water supply impacts of other rules involving similar controls. The potential water demand was determined to be within the capacity of water supplied from various sources in the Bay Area (estimated water demand of about 1.88 trillion gallons per year in 2010) (BAAQMD, 2005) and is not considered significant compared with current and projected future demand and supply. While there are projected drought-year shortages in some regions of California, these shortages would occur regardless of the proposed control measures. The use of other control technologies, such as water scrubbers or HEPA filters, could require more or less water use. The proposed rule is not expected to deplete groundwater supplies or interfere with groundwater recharge. Therefore, no significant impacts on groundwater supplies or are expected due to the proposed implementation of Rule 6-2.

VIII c - f. No significant adverse impacts on hydrology/water quality resources are anticipated from implementation of the proposed rule, which would apply to existing commercial restaurant facilities and only require alternations to the existing cooking facilities. Therefore the proposed rule is not expected to alter the existing drainage or drainage patterns of the site, result in erosion or siltation, alter of the course of a stream

or river, or substantially increase the rate or amount of surface runoff in a manner that would result in flooding onsite or offsite. Nor is the proposed rule expected to create or contribute runoff water that would exceed the capacity of existing or planned storm water drainage systems or provide substantial additional sources of polluted runoff. The proposed rule is not expected to degrade water quality. Therefore, no significant adverse impacts are expected.

VIII g – i. Owners/operators of facilities affected by the proposed rule would be required to install catalytic oxidizers or other emission control devices on conveyORIZED charbroilers and electrostatic precipitators, HEPA filters or some other control devices on large under-fired charbroilers. The proposed rule is not expected to place any additional structures within 100-year flood zones or other areas subject to flooding. Therefore, no significant adverse impacts due to flooding are expected.

VIII j. Owners/operators of facilities affected by the proposed rule would be required to install emission control devices on existing equipment. The rule is not expected to place any additional structures within areas subject to inundation by seiche, tsunami or mudflow. Therefore, no significant adverse impacts on hydrology/water due to seiche, tsunami or mudflow are expected.

	Potentially Significant Impact	Less Than Significant Impact With Mitigation Incorporated	Less Than Significant Impact	No Impact
--	--------------------------------	---	------------------------------	-----------

IX. LAND USE AND PLANNING. Would the project:

- | | | | | |
|--|--------------------------|--------------------------|--------------------------|-------------------------------------|
| a) Physically divide an established community? | <input type="checkbox"/> | <input type="checkbox"/> | <input type="checkbox"/> | <input checked="" type="checkbox"/> |
| b) Conflict with any applicable land use plan, policy, or regulation of an agency with jurisdiction over the project (including, but not limited to a general plan, specific plan, local coastal program or zoning ordinance) adopted for the purpose of avoiding or mitigating an environmental effect? | <input type="checkbox"/> | <input type="checkbox"/> | <input type="checkbox"/> | <input checked="" type="checkbox"/> |
| c) Conflict with any applicable habitat conservation plan or natural community conservation plan? | <input type="checkbox"/> | <input type="checkbox"/> | <input type="checkbox"/> | <input checked="" type="checkbox"/> |

Setting

The BAAQMD covers all of Alameda, Contra Costa, Marin, San Francisco, San Mateo, Santa Clara, and Napa Counties and portions of southwestern Solano and southern Sonoma Counties. The area of coverage is vast (about 5,600 square miles) so that land uses vary greatly and include commercial, industrial, residential, agricultural, and open space uses. The facilities affected by the proposed rule are located in the commercial areas throughout the Bay Area.

Regulatory Background

Land uses are generally protected and regulated by the City and/or County General Plans through land use and zoning requirements.

Discussion of Impacts

IX a-c. Owners/operators of facilities affected by the proposed rule would be required to install emission control devices on existing equipment in commercial areas for restaurants that operate conveyerized charbroilers or large under-fired charbroilers. Installation of the control equipment is not expected to result in any physical changes that would require construction outside of the confines of the existing facilities or alter existing land use. Therefore, no adverse significant land use impacts are expected due to the proposed project.

	Potentially Significant Impact	Less Than Significant Impact With Mitigation Incorporated	Less Than Significant Impact	No Impact
--	--------------------------------	---	------------------------------	-----------

X. MINERAL RESOURCES. Would the project:

- | | | | | |
|--|--------------------------|--------------------------|--------------------------|-------------------------------------|
| a) Result in the loss of availability of a known mineral resource that would be of value to the region and the residents of the state? | <input type="checkbox"/> | <input type="checkbox"/> | <input type="checkbox"/> | <input checked="" type="checkbox"/> |
| b) Result in the loss of availability of a locally important mineral resource recovery site delineated on a local general plan, specific plan, or other land use plan? | <input type="checkbox"/> | <input type="checkbox"/> | <input type="checkbox"/> | <input checked="" type="checkbox"/> |

Setting

The BAAQMD covers all of Alameda, Contra Costa, Marin, San Francisco, San Mateo, Santa Clara, and Napa Counties and portions of southwestern Solano and southern Sonoma Counties. The area of coverage is vast (about 5,600 square miles) so that land uses and the affected environment vary greatly throughout the area. The facilities affected by the proposed rule are located in commercial areas throughout the Bay Area.

Regulatory Background

Mineral resources are generally protected and regulated by the City and/or County General Plans through land use and zoning requirements.

Discussion of Impacts

X a-b. Owners/operators of facilities affected by the proposed rule would be required to install catalytic oxidizers or other emission control devices on coverized charbroilers and electrostatic precipitators, HEPA filters or other emission control devices on under-fired charbroilers in restaurants in commercial areas. Installation of the control equipment is not expected to result in any action that would result in the loss of availability of a known mineral resource that would be of value to the region and the residents of the state, or of a locally important mineral resource recovery site delineated on a local general plan, specific plan or other land use plan. A catalytic oxidizer will generate radiant heat back into the cooking equipment, that in turn will require less natural gas or electricity consumption to operate. The use of a HEPA filter or electrostatic precipitator to control an under-fired charbroiler will require more electricity, however, the District has determined that the additional power usage on a per restaurant basis is not significant compared to the power the restaurant uses to operate cooking, heating, cooling, and ventilation equipment. New installations of under-fired charbroilers will be required to install listed hoods. The use of listed hoods, even with the additional power usage caused by the control device, should result in a net reduction of electrical power usage compared to a new, unabated restaurant without a listed hood. Therefore, no significant impacts on mineral resources are expected.

	Potentially Significant Impact	Less Than Significant Impact With Mitigation Incorporated	Less Than Significant Impact	No Impact
--	--------------------------------	---	------------------------------	-----------

XI. NOISE. Would the project:

a) Expose persons to or generate noise levels in excess of standards established in the local general plan or noise ordinance, or applicable standards of other agencies?	<input type="checkbox"/>	<input type="checkbox"/>	<input type="checkbox"/>	<input checked="" type="checkbox"/>
b) Expose persons to or generate of excessive ground borne vibration or ground borne noise levels?	<input type="checkbox"/>	<input type="checkbox"/>	<input type="checkbox"/>	<input checked="" type="checkbox"/>
c) Result in a substantial permanent increase in ambient noise levels in the project vicinity above levels existing without the project?	<input type="checkbox"/>	<input type="checkbox"/>	<input type="checkbox"/>	<input checked="" type="checkbox"/>
d) Result in a substantial temporary or periodic increase in ambient noise levels in the project vicinity above levels existing without the project?	<input type="checkbox"/>	<input type="checkbox"/>	<input type="checkbox"/>	<input checked="" type="checkbox"/>

- e) Be located within an airport land use plan or, where such a plan has not been adopted, within two miles of a public airport or public use airport and expose people residing or working in the project area to excessive noise levels?
- f) Be located within the vicinity of a private airstrip and expose people residing or working in the project area to excessive noise levels?

Setting

The BAAQMD covers all of Alameda, Contra Costa, Marin, San Francisco, San Mateo, Santa Clara, and Napa Counties and portions of southwestern Solano and southern Sonoma Counties. The area of coverage is vast (about 5,600 square miles) so that land uses and the affected environment vary greatly throughout the area. The facilities affected by the proposed rule are located in commercial areas throughout the Bay Area. Most affected facilities are surrounded by other commercial facilities.

Regulatory Background

Noise issues related to construction and operation activities are addressed in local General Plan policies and local noise ordinance standards. The General Plan and noise ordinances generally establish allowable noise limits within different land uses including residential areas, other sensitive use areas (e.g., schools, churches, hospitals, and libraries), commercial areas, and industrial areas.

Discussion of Impacts

XI a-f. Owners/operators of facilities affected by the proposed rule would be required to install catalytic oxidizers or other emission control devices on existing equipment in commercial areas. Installation of the control equipment, whether atop a cooking device or roof-mounted, is not expected to result in any physical changes to the facilities that would generate additional noise. The control devices are not expected to result in noise increases over the current noise levels of existing commercial cooking facilities. Therefore, no adverse significant impacts to noise are expected due to the proposed project.

	Potentially Significant Impact	Less Than Significant Impact with Mitigation Incorporated	Less Than Significant Impact	No Impact
--	--------------------------------	---	------------------------------	-----------

XII. POPULATION AND HOUSING. Would the project:

- a) Induce substantial population growth in an area

either directly (e.g., by proposing new homes and businesses) or indirectly (e.g. through extension of roads or other infrastructure)?

- b) Displace a substantial number of existing housing units, necessitating the construction of replacement housing elsewhere?
- c) Displace a substantial number of people, necessitating the construction of replacement housing elsewhere?

Setting

The BAAQMD covers all of Alameda, Contra Costa, Marin, San Francisco, San Mateo, Santa Clara, and Napa Counties and portions of southwestern Solano and southern Sonoma Counties. The area of coverage is vast (about 5,600 square miles) so that land uses and the affected environment vary greatly throughout the area. The facilities affected by the proposed rule are located in commercial areas throughout the Bay Area.

Regulatory Background

Population and housing growth and resources are generally protected and regulated by the City and/or County General Plans through land use and zoning requirements.

Discussion of Impacts

XII a. Owners/operators of facilities affected by the proposed rule would be required to install catalytic oxidizers or other emission control devices on conveyORIZED charbroilers and electrostatic precipitators or HEPA filters on certain restaurants in commercial areas. Installation activities would involve minor changes to existing cooking equipment or to roof-mounted exhaust systems. Installation of the control equipment is not expected to result in any physical changes to the facilities and would not affect population or housing. The minor installation activities are expected to be completed by existing workers or contractors. No additional workers are expected to be required at the affected facilities; therefore no adverse significant impacts to population or housing are expected due to the proposed project.

XII b-c. The commercial cooking equipment already exists and is located within the confines of existing facilities within commercial areas. No housing would be impacted or removed by the proposed rule and no displacement of housing would occur. Therefore, no significant adverse impacts on population/housing are expected.

	Potentially Significant Impact	Less Than Significant Impact With Mitigation Incorporated	Less Than Significant Impact	No Impact
--	--------------------------------	---	------------------------------	-----------

XIII. PUBLIC SERVICES. Would the project:

a. Result in substantial adverse physical impacts associated with the provision of new or physically altered governmental facilities or a need for new or physically altered governmental facilities, the construction of which could cause significant environmental impacts, in order to maintain acceptable service ratios, response times, or other performance objectives for any of the following public services:

Fire protection?	<input type="checkbox"/>	<input type="checkbox"/>	<input checked="" type="checkbox"/>	<input type="checkbox"/>
Police protection?	<input type="checkbox"/>	<input type="checkbox"/>	<input type="checkbox"/>	<input checked="" type="checkbox"/>
Schools?	<input type="checkbox"/>	<input type="checkbox"/>	<input type="checkbox"/>	<input checked="" type="checkbox"/>
Parks?	<input type="checkbox"/>	<input type="checkbox"/>	<input type="checkbox"/>	<input checked="" type="checkbox"/>
Other public facilities?	<input type="checkbox"/>	<input type="checkbox"/>	<input type="checkbox"/>	<input checked="" type="checkbox"/>

Setting

The BAAQMD covers all of Alameda, Contra Costa, Marin, San Francisco, San Mateo, Santa Clara, and Napa Counties and portions of southwestern Solano and southern Sonoma Counties. The area of coverage is vast (about 5,600 square miles) so that land uses and the affected environment vary greatly throughout the area. The facilities affected by the proposed rule are located in commercial areas throughout the Bay Area.

Given the large area covered by the BAAQMD, public services are provided by a wide variety of local agencies. Fire protection and police protection/law enforcement services within the BAAQMD are provided by various districts, organizations, and agencies. There are several school districts, private schools, and park departments within the BAAQMD. Public facilities within the BAAQMD are managed by different county, city, and special-use districts.

Regulatory Background

City and/or County General Plans usually contain goals and policies to assure adequate public services are maintained within the local jurisdiction.

Discussion of Impacts

XIII a. Owners/operators of facilities affected by the proposed rule would be required to install catalytic oxidizers or other emission control devices on conveyORIZED charbroilers and electrostatic precipitators or HEPA filters on under-fired charbroilers in certain restaurants in commercial areas. Installation activities would involve minor changes to existing cooking equipment. Catalytic oxidizers used to control conveyORIZED charbroilers would reduce the chance of fire from accumulation of grease in the ductwork and exhaust system, a common source of restaurant fires. Electrostatic precipitators, if not properly maintained, could potentially create a fire hazard that does not currently exist. Building permits to install this equipment would require periodic cleaning and fire suppression systems, and proposed Rule 6-2 also requires that control equipment be cleaned and maintained as per manufacturers' instructions. Proper cleaning and maintenance prevents an increased fire safety risk as well as ensures the control equipment reduces air pollutants as intended. Consequently, no significant impacts on the need for fire or police protection are expected. The proposed rule is not expected to require additional workers at the facilities or result in population growth so no impacts on schools or parks are expected. Therefore, no significant adverse impacts on public services are expected.

	Potentially Significant Impact	Less Than Significant Impact With Mitigation Incorporated	Less Than Significant Impact	No Impact
--	--------------------------------	---	------------------------------	-----------

XIV. RECREATION. Would the project:

- | | | | | |
|--|--------------------------|--------------------------|--------------------------|-------------------------------------|
| a) Increase the use of existing neighborhood and regional parks or other recreational facilities such that substantial physical deterioration of the facility would occur or be accelerated? | <input type="checkbox"/> | <input type="checkbox"/> | <input type="checkbox"/> | <input checked="" type="checkbox"/> |
| b) Include recreational facilities or require the construction or expansion of recreational facilities that might have an adverse physical effect on the environment? | <input type="checkbox"/> | <input type="checkbox"/> | <input type="checkbox"/> | <input checked="" type="checkbox"/> |

Setting

The BAAQMD covers all of Alameda, Contra Costa, Marin, San Francisco, San Mateo, Santa Clara, and Napa Counties and portions of southwestern Solano and southern Sonoma Counties. The area of coverage is vast (about 5,600 square miles) so that there are numerous areas for recreational activities. The facilities affected by the proposed rule are located in commercial areas throughout the Bay Area. Public recreational land uses are generally not located within the confines of commercial facilities.

Regulatory Background

Recreational areas are generally protected and regulated by the City and/or County General Plans at the local level through land use and zoning requirements. Some parks and recreation areas are designated and protected by state and federal regulations.

Discussion of Impacts

XIV a-b. Owners/operators of facilities affected by the proposed rule would be required to install catalytic oxidizers or other emission control devices on conveyORIZED charbroilers and electrostatic precipitators or HEPA filters on under-fired charbroilers in certain restaurants in commercial areas. Installation activities would involve minor changes to existing cooking equipment. Installation of the control equipment is not expected to result in any physical changes to the facilities. The proposed rule is not expected to require additional workers at the facilities or result in population growth so no impacts on recreation are expected. Therefore, no significant adverse impacts on recreation are expected

	Potentially Significant Impact	Less Than Significant Impact With Mitigation Incorporated	Less Than Significant Impact	No Impact
--	--------------------------------	---	------------------------------	-----------

XV. TRANSPORTATION/TRAFFIC. Would the project:

a) Cause an increase in traffic that is substantial in relation to the existing traffic load and capacity of the street system (i.e., result in a substantial increase in the number of vehicle trips, the volume-to-capacity ratio on roads, or congestion at intersections)?	<input type="checkbox"/>	<input type="checkbox"/>	<input type="checkbox"/>	<input checked="" type="checkbox"/>
b) Cause, either individually or cumulatively, exceedance of a level-of-service standard established by the county congestion management agency for designated roads or highways?	<input type="checkbox"/>	<input type="checkbox"/>	<input type="checkbox"/>	<input checked="" type="checkbox"/>
c) Result in a change in air traffic patterns, including either an increase in traffic levels or a change in location that results in substantial safety risks?	<input type="checkbox"/>	<input type="checkbox"/>	<input type="checkbox"/>	<input checked="" type="checkbox"/>
d) Substantially increase hazards because of a design feature (e.g. sharp curves or dangerous intersections) or incompatible uses (e.g. farm equipment)?	<input type="checkbox"/>	<input type="checkbox"/>	<input type="checkbox"/>	<input checked="" type="checkbox"/>
e) Result in inadequate emergency access?	<input type="checkbox"/>	<input type="checkbox"/>	<input type="checkbox"/>	<input checked="" type="checkbox"/>
f) Result in inadequate parking capacity?	<input type="checkbox"/>	<input type="checkbox"/>	<input type="checkbox"/>	<input checked="" type="checkbox"/>

- g) Conflict with adopted policies, plans, or programs supporting alternative transportation (e.g. bus turnouts, bicycle racks)?

Setting

The BAAQMD covers all of Alameda, Contra Costa, Marin, San Francisco, San Mateo, Santa Clara, and Napa Counties and portions of southwestern Solano and southern Sonoma Counties. The area of coverage is vast (about 5,600 square miles). Transportation systems located within the Bay Area include railroads, airports, waterways, and highways. The Port of Oakland and three international airports in the area serve as hubs for commerce and transportation. The transportation infrastructure for vehicles and trucks in the Bay Area ranges from single lane roadways to multilane interstate highways. The Bay Area contains over 19,600 miles of local streets and roads, and over 1,400 miles of state highways. In addition, there are over 9,040 transit route miles of services including rapid rail, light rail, commuter, diesel and electric buses, cable cars, and ferries. The Bay Area also has an extensive local system of bicycle routes and pedestrian paths and sidewalks. At a regional level, the share of workers driving alone was about 68 percent in 2000. The portion of commuters that carpool was about 12.9 percent in 2000. About 3.2 percent of commuters walked to work in 2000. In addition, other modes of travel (bicycle, motorcycle, etc.), account for 2.2 percent of commuters in 2000 (MTC, 2004).

Cars, buses, and commercial vehicles travel about 143 million miles a day (2000) on the Bay Area Freeways and local roads. Transit serves about 1.7 million riders on the average weekday (MTC, 2004).

The region is served by numerous interstate and U.S. freeways. On the west side of San Francisco Bay, Interstate 280 and U.S. 101 run north-south. U.S. 101 continues north of San Francisco into Marin County. Interstates 880 and 660 run north-south on the east side of the Bay. Interstate 80 starts in San Francisco, crosses the Bay Bridge, and runs northeast toward Sacramento. Interstate 80 is a six-lane north-south freeway which connects Contra Costa County to Solano County via the Carquinez Bridge. State Routes 29 and 84, both highways that allow at-grade crossings in certain parts of the region, become freeways that run east-west and across the Bay. Interstate 580 starts in San Rafael, crosses the Richmond-San Rafael Bridge, joins with Interstate 80, runs through Oakland, and then runs eastward toward Livermore. From the Benicia-Martinez Bridge, Interstate 680 extends north to Interstate 80 in Cordelia. Caltrans constructed a second freeway bridge adjacent and east of the existing Benicia-Martinez Bridge. The new bridge consists of five northbound traffic lanes. The existing bridge was re-striped to accommodate four lanes for southbound traffic. Interstate 780 is a four lane, east-west freeway extending from the Benicia-Martinez Bridge west to I-80 in Vallejo.

Regulatory Background

Transportation planning is usually conducted at the county level. Each Bay Area County has a Congestion Management Agency. The Congestion Management Agency is responsible for transportation planning and administration of improvement projects in each county and in some cases, shares these responsibilities with the county departments. County development agencies conduct and oversee the transportation and planning

for new development projects while the Congestion Management Agency implements the transportation programs and projects.

Discussion of Impacts

XV a-b. Owners/operators of facilities affected by the proposed rule would be required to install emission control devices on conveyORIZED charbroilers and large under-fired charbroilers in commercial areas. Installation activities would involve minor changes to existing cooking equipment or roof-mounted equipment in exhaust systems. Installation of the control equipment is not expected to result in any physical changes to the facilities. The proposed rule does not require the installation of pieces of equipment large enough to affect traffic or affect access of any emergency service. No impacts on the need for fire or police protection are expected. The proposed rule is expected to be conducted by existing workers or existing contractors so that no additional vehicle trips are expected to be required. No changes to traffic patterns or levels of service at local intersections are expected. Therefore, no adverse significant impacts to traffic are expected.

XV c. The proposed rule includes minor modifications to the cooking equipment of existing restaurant facilities. The project will not involve the delivery of materials via air so no increase and no adverse impacts in air traffic are expected.

XV d - e. The proposed rule is not expected to increase traffic hazards or create incompatible uses at or adjacent to the site. Emergency access provided at the facilities, will continue to be maintained and will not be impacted by the proposed rule.

XV f. The commercial cooking equipment affected by the proposed rule already exists and is located within the confines of existing facilities within commercial areas. The proposed rule does not require the installation of new pieces of equipment large enough to significantly affect parking capacity, except temporarily during installation, at which time the restaurant would not be operational and would therefore likely have adequate parking onsite. Parking required for installation contractors would be provided onsite. No increase in permanent workers is expected. Therefore, the proposed rule will not result in significant adverse impacts on parking.

XV g. The proposed rule will result in fewer PM and VOC emissions from affected facilities. The proposed rule is not expected to conflict with adopted policies, plans, or programs supporting alternative transportation modes (e.g., bus turnouts, bicycle racks).

	Potentially Significant Impact	Less Than Significant Impact With Mitigation Incorporated	Less-than- Significant Impact	No Impact
--	--------------------------------------	---	-------------------------------------	--------------

XVI. UTILITIES AND SERVICE SYSTEMS.

Would the project:

- a) Exceed wastewater treatment requirements of the applicable Regional Water Quality Control Board?

- | | | | | |
|---|--------------------------|--------------------------|-------------------------------------|-------------------------------------|
| b) Require or result in the construction of new water or wastewater treatment facilities or expansion of existing facilities, the construction of which could cause significant environmental effects? | <input type="checkbox"/> | <input type="checkbox"/> | <input type="checkbox"/> | <input checked="" type="checkbox"/> |
| c) Require or result in the construction of new storm water drainage facilities or expansion of existing facilities, the construction of which could cause significant environmental effects? | <input type="checkbox"/> | <input type="checkbox"/> | <input type="checkbox"/> | <input checked="" type="checkbox"/> |
| d) Have sufficient water supplies available to serve the project from existing entitlements and resources, or would new or expanded entitlements needed? | <input type="checkbox"/> | <input type="checkbox"/> | <input type="checkbox"/> | <input checked="" type="checkbox"/> |
| e) Result in a determination by the wastewater treatment provider which serves or may serve the project that it has adequate capacity to serve the project's projected demand in addition to the provider's existing commitments? | <input type="checkbox"/> | <input type="checkbox"/> | <input type="checkbox"/> | <input checked="" type="checkbox"/> |
| f) Be served by a landfill with sufficient permitted capacity to accommodate the project's solid waste disposal needs? | <input type="checkbox"/> | <input type="checkbox"/> | <input checked="" type="checkbox"/> | <input type="checkbox"/> |
| g) Comply with federal, state, and local statutes and regulations related to solid waste? | <input type="checkbox"/> | <input type="checkbox"/> | <input type="checkbox"/> | <input checked="" type="checkbox"/> |

Setting

The BAAQMD covers all of Alameda, Contra Costa, Marin, San Francisco, San Mateo, Santa Clara, and Napa Counties and portions of southwestern Solano and southern Sonoma Counties. The area of coverage is vast (about 5,600 square miles) so that land uses and the affected environment vary greatly throughout the area.

Given the large area covered by the BAAQMD, public utilities are provided by a wide variety of local agencies. The affected facilities have wastewater and storm water treatment facilities and discharge treated wastewater under the requirements of NPDES permits.

Water is supplied to affected facilities by several water purveyors in the Bay Area. Solid waste is handled through a variety of municipalities, through recycling activities and at disposal sites.

There are no hazardous waste disposal sites within the jurisdiction of the BAAQMD. Hazardous waste generated at area facilities, which is not reused on-site, or recycled off-site, is disposed of at a licensed in-state hazardous waste disposal facility. Two such facilities are the Chemical Waste Management Inc. (CWMI) Kettleman Hills facility in King's County, and the Safety-Kleen facility in Buttonwillow (Kern County). Hazardous waste can also be transported to permitted facilities outside of California. The nearest

out-of-state landfills are U.S. Ecology, Inc., located in Beatty, Nevada; USPCI, Inc., in Murray, Utah; and Envirosafe Services of Idaho, Inc., in Mountain Home, Idaho. Incineration is provided at the following out-of-state facilities: Aptus, located in Aragonite, Utah and Coffeyville, Kansas; Rollins Environmental Services, Inc., located in Deer Park, Texas and Baton Rouge, Louisiana; Chemical Waste Management, Inc., in Port Arthur, Texas; and Waste Research & Reclamation Co., Eau Claire, Wisconsin.

Regulatory Background

City and/or County General Plans usually contain goals and policies to assure adequate utilities and service systems are maintained within the local jurisdiction.

Discussion of Impacts

XVI a, b, d and e. The commercial cooking equipment affected by the proposed rule already exists and is located within the confines of existing facilities within commercial areas. The proposed rule does not require the installation of new large pieces of equipment or require new public services. Facilities are expected to comply by installing control technology consisting of catalytic oxidizers (in the case of conveyORIZED charbroilers) or electrostatic precipitators or HEPA filters (in the case of under-fired charbroilers). Once the equipment is installed, the rule is not expected to result in any physical changes to the facilities. The cleaning of equipment may result in a slight increase in water consumption; however, the wastewater generated will be processed by the restaurants' grease traps and additional grease will not be introduced into existing wastewater treatment facilities. The 2005 Ozone Strategy addressed the impacts of the proposed control measures on water demand. Although FS-3 was not part of the control strategy, the analysis did consider water supply impacts of other rules involving similar controls. The potential water demand was determined to be within the capacity of water supplied from various sources in the Bay Area (estimated water demand of about 1,880 billion gallons per year in 2010) (CARB, 2000) and is not considered significant compared with current and projected future demand and supply. While there are projected drought-year shortages in some regions of California, these shortages would occur regardless of the proposed control measures. Based upon the above considerations, no significant adverse impacts on water demand were expected due to implementation of the control measures within the 2005 Ozone Strategy. Therefore, no significant impacts on water use or wastewater discharges are expected due to proposed Rule 6-2. No significant adverse impacts on utilities and service systems are anticipated from the proposed rule would apply to existing facilities with commercial cooking equipment.

XVI c. Owners/operators of facilities affected by the proposed rule would be required to install catalytic oxidizers or other emission control devices on existing equipment in commercial areas. Installation activities would involve minor changes to existing cooking equipment or roof-mounted exhaust systems. Installation of the control equipment is not expected to result in any physical changes to the facilities. Therefore, no changes to or increases in storm water are expected due to the proposed rule.

XVI f. Restaurants generate grease from cooking operations, that is collected in grease traps and professionally disposed of in landfills or composted. The proposed rule is expected to generate an additional amount of additional grease, due to the capture of the grease within control equipment rather than release onto the restaurant roof or into the environment. The amount generated would be less than significant. Under-fired charbroilers would likely comply by the use of an electrostatic precipitator or HEPA filter. HEPA filters are not likely to be the more popular option; however, the filters themselves would have to be

replaced periodically, and the used filters disposed of. This would generate solid waste that the restaurant would not otherwise generate. HEPA filters would constitute a small addition to the waste that a restaurant already generates. Consequently, any additional increase on waste generation is expected to be less than significant.

XVI g. The proposed rule would not affect the ability of facilities to comply with federal, state, and local statutes and regulations related to solid waste. No significant impacts on waste generation are expected from the proposed rule.

	Potentially Significant Impact	Less Than Significant Impact With Mitigation Incorporated	Less Than Significant Impact	No Impact
--	--------------------------------------	---	------------------------------------	-----------

XVII. MANDATORY FINDINGS OF SIGNIFICANCE.

- | | | | | |
|--|--------------------------|--------------------------|--------------------------|-------------------------------------|
| <p>a) Does the project have the potential to degrade the quality of the environment, substantially reduce the habitat of a fish or wildlife species, cause a fish or wildlife population to drop below self-sustaining levels, threaten to eliminate a plant or animal community, reduce the number or restrict the range of a rare or endangered plant or animal, or eliminate important examples of the major periods of California history or prehistory?</p> | <input type="checkbox"/> | <input type="checkbox"/> | <input type="checkbox"/> | <input checked="" type="checkbox"/> |
| <p>b) Does the project have impacts that are individually limited, but cumulatively considerable? ("Cumulatively considerable" means that the incremental effects of a project are considerable when viewed in connection with the effects of past projects, the effects of other current projects, and the effects of probable future projects)</p> | <input type="checkbox"/> | <input type="checkbox"/> | <input type="checkbox"/> | <input checked="" type="checkbox"/> |
| <p>c) Does the project have environmental effects that will cause substantial adverse effects on human beings, either directly or indirectly?</p> | <input type="checkbox"/> | <input type="checkbox"/> | <input type="checkbox"/> | <input checked="" type="checkbox"/> |

Discussion of Impacts

XVII a. The proposed rule does not have the potential to degrade the quality of the environment, reduce the habitat of a fish or wildlife species, cause a fish or wildlife population to drop below self-sustaining levels, threaten to eliminate a plant or animal community, reduce the number or restrict the range of a rare or endangered plant or animal, or eliminate important examples of the major periods of California history or prehistory, as discussed in the previous sections of the CEQA checklist. The proposed rule is expected to

result in emission reductions from facilities with commercial cooking equipment thus providing a beneficial air quality impact and improvement in air quality. No significant adverse impacts are expected.

XVII b. Proposed Rule 6-2 is expected to result in emission reductions of VOC and PM from affected facilities with commercial cooking equipment, thus providing a beneficial air quality impact and improvement in air quality. The proposed rule is part of a long-term plan to bring the Bay Area into compliance with the state ambient air quality standards for ozone and reduce emissions of particulate matter. The proposed rule does not have adverse environmental impacts that are limited individually, but cumulatively considerable when considered in conjunction with other regulatory control projects. The proposed rule is not expected to have environmental effects that will cause substantial adverse effects on human beings, either directly or indirectly. No significant adverse impacts are expected.

XVII c. The proposed rule is expected to result in emission reductions from affected facilities, thus providing a beneficial air quality impact and improvement in air quality. The proposed rule is part of a long-term plan to bring the Bay Area into compliance with the state ambient air quality standards for ozone and reduce emissions of particulate matter, thus reducing the potential health impacts due to these pollutants. The proposed rule is not expected to have significant adverse effects (either directly or indirectly) to human beings.

HLH\2519-BAAQMD\2519R6R2Ch.3CheckList..doc

Chapter 4**References**

- South Coast Area Air Quality Management District (SCAQMD), 1997. Subsequent Environmental Assessment for Proposed Rule 1138 – Control of Emissions from Restaurant Operations, July 29, 1997.
- Bay Area Air Quality Management District (BAAQMD), 2001. Revised 2001 San Francisco Bay Area Ozone Attainment Plan for the 1-hour National Ozone Standard, adopted October 24, 2001.
- BAAQMD, 2004. Toxic Air Contaminant 2002 Annual Report. June, 2004.
- BAAQMD, 2004. Initial Study/Negative Declaration for the Amendments to Bay Area Air Quality Management District Regulation 8, Rule 8. June 2004.
- BAAQMD, 2005. Draft Staff Report, Proposed Amendments to Regulation 8, Rule 28: Episodic Releases from Pressure Relief Devices at Petroleum Refineries and Chemical Plants, August 12, 2005.
- BAAQMD, 2005. 2005 BAAQMD Ambient Air Quality Data.
- BAAQMD, 2006. Bay Area 2005 Ozone Strategy, January 4, 2006
- BAAQMD, 2006. Initial Study/Negative Declaration for the Amendments to Bay Area Air Quality Management District Regulation 8, Rule 5. September 2006.
- BAAQMD, 2006. Initial Study/Negative Declaration for the Amendments to Bay Area Air Quality Management District Regulation 9, Rule 9. October 2006.
- BAAQMD, 2006. Workshop Report, Proposed Regulation 6, Rule 2: Control of Emissions from Commercial Cooking Equipment, October 2006.
- BAAQMD, 2007. Public Workshop Notice for the proposed Bay Area Air Quality Management District Regulation 6, Rule 2. January 2007.
- BAAQMD, 2007. Public Workshop Notice for the proposed Bay Area Air Quality Management District Regulation 6, Rule 2. October 2007.
- BAAQMD, 2007. Draft Staff Report, Proposed Regulation 6, Rule 2: Commercial Cooking Equipment. October, 2007.