

Document Type: EIS-Administrative Record
Index Field: Environmental Document
Transmitted Public/Agencies
Project Name: Watts Bar Nuclear Plant Unit 2
Completion
Project Number: 2006-124

FINAL SUPPLEMENTAL ENVIRONMENTAL IMPACT STATEMENT

**COMPLETION AND OPERATION OF WATTS BAR
NUCLEAR PLANT UNIT 2**
Rhea County, Tennessee

TENNESSEE VALLEY AUTHORITY

JUNE 2007

Page intentionally blank

Final Supplemental Environmental Impact Statement

June 2007

Proposed project: Completion and Operation of Watts Bar Nuclear Plant Unit 2
Rhea County, Tennessee

Lead agency: Tennessee Valley Authority

**For further information,
contact:** Ruth M. Horton
Senior NEPA Specialist
Tennessee Valley Authority
400 W. Summit Hill Drive, WT 11D-K
Knoxville, TN 37902
Phone: 865/632-3719
Fax: 865/632-3451
TVA web www.tva.gov/environment/reports/wattsbar2/
e-mail: rmhorton@tva.com

Abstract: The Tennessee Valley Authority (TVA) is proposing to meet the need for additional baseload capacity on the TVA system and maximize the use of existing assets by completing and operating Watts Bar Nuclear Plant (WBN) Unit 2. The unit would be completed as originally designed, alongside its sister unit, WBN Unit 1, which has been operating since 1996. Only minimal new construction is proposed, and no expansion of the existing site footprint would be required. TVA has prepared this final supplemental environmental impact statement (FSEIS) to update the extensive previous environmental record pertinent to the proposed action. In addition to this FSEIS, TVA is also conducting a detailed, scoping, estimating and planning (DSEP) study. TVA will use information from the DSEP and the FSEIS to make a decision about whether to complete construction of and to operate WBN Unit 2.

Page intentionally blank

SUMMARY

PURPOSE OF AND NEED FOR ACTION

Demand for electricity in the Tennessee Valley Authority (TVA) power service area has grown at the average rate of 2.4 percent per year for the past 15 years. Although this high level of load growth is expected to slow somewhat, TVA anticipates having to add additional baseload capacity to its system in the next decade to meet growing demand for power. At the same time, TVA is interested in reducing fossil-fuel emissions and lowering the delivered cost of power. The proposal under consideration by TVA is to meet the need for additional baseload capacity on the TVA system and maximize the use of existing assets by completing and operating Watts Bar Nuclear Plant (WBN) Unit 2. The unit would be completed as originally designed, alongside its sister unit, WBN Unit 1, which has been operating since 1996. Producing tritium for the U.S. Department of Energy (DOE) at WBN Unit 2 is not part of this proposed action.

This final supplemental environmental impact statement (FSEIS) will inform decision makers and the public about the potential for environmental impacts associated with a decision to complete and operate WBN Unit 2. It updates the analysis of potential environmental impacts resulting from construction, operation, and maintenance of WBN Unit 2 as a supplement to the original 1972 final environmental statement (FES) titled *Final Environmental Statement, Watts Bar Nuclear Plant Units 1 and 2* (hereafter referred to as 1972 FES) and subsequent WBN-related environmental reviews. It also updates the need for power analysis.

In addition to this environmental review, a detailed, scoping, estimating, and planning (DSEP) study is underway. TVA will use information from the DSEP and the FSEIS to make an informed decision about whether to complete construction of and to operate WBN Unit 2.

NEED FOR POWER

The need for power analysis presented in Chapter 1 shows how completion of WBN Unit 2 would help TVA meet expected demands for increased baseload power, improve the diversity of resources serving its customers, reduce the risks inherent with any particular kind of resource, provide added flexibility to reduce fossil plant emissions, and potentially lower the cost of power to TVA's customers. TVA prepares a range of forecasts of future power demands on its system. Some of those forecasts show a need for additional baseload capacity as early as 2010.

ALTERNATIVES INCLUDING THE PROPOSED ACTION

In the 1972 FES for Watts Bar Units 1 and 2, TVA considered a number of alternatives to constructing and operating WBN, including the No Action Alternative. TVA is proposing to complete WBN Unit 2 as originally designed except for modifications consistent with those made to Unit 1. Consistent with the Council on Environmental Quality's National Environmental Policy Act (NEPA) regulations [§1502.4(D)], this document also tiers off of *Energy Vision 2020 – An Integrated Resource Management Plan and Final Programmatic Environmental Impact Statement* (TVA 1995a), the *Final Environmental Impact Statement for the Production of Tritium in a Commercial Light Water Reactor* (DOE 1999), and the *Reservoir Operations Study Final Programmatic Environmental Impact Statement* (TVA 2004a) and incorporates by reference the balance of the environmental record pertinent to

WBN. As such, this FSEIS identifies no new alternatives to those already addressed in those documents.

CHANGES IN THE AFFECTED ENVIRONMENT AND ENVIRONMENTAL CONSEQUENCES

The environmental consequences of constructing and operating WBN were addressed comprehensively in the 1972 FES for WBN 1 and 2. Subsequent environmental reviews updated that analysis, as described in Section 1.3 of this FSEIS. By 1996 when the construction of Unit 1 was complete, most of the construction effects had already occurred. Unit 2 would use structures that already exist and most of the work required to complete Unit 2 would occur inside of those buildings. All disturbances proposed for the construction of new support facilities would be within the current plant footprint. TVA would use standard construction best management practices (BMPs) to control minor construction impacts to air and water from dust, sedimentation, and noise.

The reviews by TVA (1993a) and the U.S. Nuclear Regulatory Commission (NRC) (1995a) hereafter referred to as the 1995 NRC FES, updated existing environmental information at that time. Some modifications to plant design and operations have occurred since that time. This document summarizes the environmental effects assessed in past WBN-related environmental reviews and assesses the potential for new or additional effects that could result from the completion and operation of Unit 2. Table S-1 summarizes the potential for additional direct, indirect, and cumulative environmental effects.

Table S-1. Summary of Direct, Indirect, and Cumulative Environmental Effects From Completion of WBN Unit 2

Resource	Potential Environmental Effects
Surface Water Quality	Insignificant hydrothermal effects on near-field and far-field temperatures and on the operation of the supplemental condenser cooling water (SCCW), given compliance with National Pollutant Discharge System (NPDES) permit limits. Insignificant effects from raw water chemical treatment. Water intake would increase by 33 percent over present conditions but still would be within the original design basis of the plant for two-unit operation. A corresponding increase of essential raw cooling water and raw cooling water chemical additives of 33 percent would occur. Towerbrom treatment for Condensing Cooling Water (CCW) would increase 100 percent. These increases are not expected to affect compliance with existing NPDES effluent limitations that protect aquatic resources.
Groundwater Quality	No impacts expected.

Table S-1 (continued)

Resource	Potential Environmental Effects
Aquatic Ecology	Since no construction activities would occur within 500 feet of the reservoir, all construction activities would be subject to appropriate BMPs to ensure that there are no impacts to surface water, intake flows would stay within the original design basis for operation of the two-units in closed cycle mode, and discharge changes would remain within existing NPDES limits. Any impacts to aquatic ecology, plankton, or aquatic communities in the vicinity of WBN would be insignificant.
Terrestrial Ecology	Impacts on existing plant and animal communities within or adjacent to the disturbed area footprint would be insignificant. Some minor disturbance of communities may occur during construction. No new infestations of exotic invasive plant species are expected.
Threatened and Endangered Species	<p>All construction work would be conducted using BMPs, no additional discharge-related impacts would occur, and intake flows would not be increased over the original design basis for two-unit operation. There would be no effect on state-listed or federally listed aquatic animals or their habitats.</p> <p>No impacts to threatened or endangered terrestrial plant or animal species are expected. No occurrences of state-listed or federally listed plant species are known on, or adjacent to WBN. No impacts to bald eagles or gray bats are expected.</p>
Wetlands	No impacts to wetlands are expected. No disturbance is planned that would affect the one forested wetland adjacent to the project footprint.
Natural Areas	No impacts would occur to the five natural areas within 5 miles of WBN, including the Chickamauga State Mussel Sanctuary.
Cultural Resources (Archaeological and Historical)	Because new ground disturbance would be minimal and only minimal new construction is planned, historic resources on and adjacent to the site and archaeological resources within the area of potential effect would not be adversely affected.
Socioeconomics, Environmental Justice and Land Use	Some impacts to population, including low income and minority groups due to influx of workers; most impacts would be widespread and minor. A noticeable increase in demand for housing and mobile housing locations would occur during peak construction. Some impacts are expected to schools. Minor impacts are expected on land use. Beneficial effects on employment and income, and local governments' revenues during construction.
Floodplains and Flood Risk	No anticipated adverse flood-related impacts.
Seismic Effects	No adverse seismic effects anticipated.

Table S-1 (continued)

Resource	Potential Environmental Effects
Climatology and Meteorology	A slight change in local meteorology could affect wind dispersion values. Effects expected to be insignificant.
Nuclear Plant Safety and Security	The risks of a beyond-design-basis accident from operation of WBN are small. Increased risk from Unit 2 operation would be extremely low. Risk of and potential impacts from a terrorist attack on WBN are not expected to increase significantly due to completion of WBN Unit 2. Because WBN is an existing, operating nuclear facility, the risks and potential consequences of a terrorist attack already exist, and safeguards have already been taken to protect against such risks.
Radiological Effects	Anticipated effects unchanged since 1995; insignificant.
Radiological Waste	Anticipated effects unchanged since 1995; insignificant.
Spent Fuel Transportation and Storage	Insignificant effects anticipated from the transport or storage of spent fuel.

The cumulative effects of constructing and operating Units 1 and 2 were considered in the 1972 FES and the 1995 NRC FES which TVA adopted. Potential cumulative effects to surface water and aquatic ecology from operating both units in the future would be addressed and controlled by monitoring requirements and NPDES permit limits. Previous reviews also considered the potential for cumulative effects to air from Watts Bar Fossil Plant, which had not operated since 1983 and has since been retired. Cumulative effects are also considered in many of the documents incorporated by reference and/or tiered from for this supplement. Most notably, cumulative effects of transportation and storage of spent fuel were addressed in the DOE 1999 final environmental impact statement; cumulative effects of transportation of radioactive materials were addressed in NRC's *Environmental Survey of Transportation of Radioactive Materials to and from Nuclear Power Plants, Supplement 1* (NUREG-75/038, NRC 1975); and cumulative effects of hydrothermal and water supply were addressed in TVA 2004a.

IDENTIFICATION OF MITIGATION MEASURES

Mitigation of potential or actual environmental impacts includes avoiding, minimizing, rectifying, reducing, or compensating for the impacts. Mitigation measures have been identified in the 1972 FES and subsequent NEPA documents. Those measures are still in effect. This supplemental document identifies mitigation measures to address impacts beyond what were discussed in those earlier reviews. TVA will identify specific mitigations and commitments selected for implementation in the Record of Decision (ROD) for this project.

TVA has identified the following measures that could be implemented during construction or operation of WBN Unit 2 to address those potential impacts.

TVA would designate certain counties as impacted by the construction process. This would make them eligible for a supplemental allocation from TVA's annual tax equivalent payment under Tennessee law. These funds could be used by counties to address impacts on county services.

As part of the DSEP, TVA is conducting a labor study of the potential construction workforce. TVA would provide information from this study to officials in the impacted counties. This information could help with local planning to accommodate the anticipated temporary population growth.

Page intentionally blank

TABLE OF CONTENTS

1.0	PURPOSE OF AND NEED FOR ACTION	1
1.1.	The Decision	1
1.2.	Background	1
1.3.	Other Pertinent Environmental Reviews and Tiering	5
1.4.	Scoping and Draft SEIS Review	9
1.4.1.	Scoping.....	9
1.4.2.	Draft SEIS Review.....	9
1.5.	Environmental Permits and Approvals.....	10
1.6.	Need for Power	11
2.0	ALTERNATIVES INCLUDING THE PROPOSED ACTION	19
2.1.	Proposed Action.....	19
2.2.	Changes in Plant Design and Operational Systems Since 1995.....	21
2.2.1.	Plant Water Use.....	21
2.2.2.	Heat Dissipation System	21
2.3.	Other Activities	27
2.4.	Summary of Environmental Effects.....	29
2.5.	Identification of Mitigation Measures.....	31
2.6.	The Preferred Alternative	32
3.0	CHANGES IN THE AFFECTED ENVIRONMENT AND ENVIRONMENTAL CONSEQUENCES	33
3.1.	Water Quality.....	34
3.1.1.	Surface Water – Hydrothermal Effects.....	34
3.1.2.	Surface Water – Chemical Additives to Raw Water	46
3.1.3.	Groundwater	53
3.2.	Aquatic Ecology.....	54
3.3.	Terrestrial Ecology	56
3.3.1.	Plants.....	56
3.3.2.	Wildlife	57
3.4.	Threatened and Endangered Species	57
3.4.1.	Aquatic Animals.....	57
3.4.2.	Plants.....	59
3.4.3.	Wildlife	60
3.5.	Wetlands	61
3.6.	Natural Areas	61
3.7.	Cultural Resources.....	62
3.8.	Socioeconomic, Environmental Justice, and Land Use	64
3.8.1.	Population.....	64
3.8.2.	Employment and Income.....	65
3.8.3.	Low-Income and Minority Populations.....	65
3.8.4.	Housing and Community Services	66
3.8.5.	Schools	67
3.8.6.	Land Use	67
3.8.7.	Local Government Revenues	68

Completion and Operation of
Watts Bar Nuclear Plant Unit 2

3.8.8. Cumulative Effects.....	68
3.9. Floodplains and Flood Risk.....	69
3.10. Seismic Effects.....	71
3.11. Climatology and Meteorology	72
3.12. Nuclear Plant Safety and Security	73
3.12.1. Severe Accident Analysis.....	73
3.12.2. Terrorism	75
3.13. Radiological Effects.....	76
3.14. Radioactive Waste	91
3.15. Spent Fuel Storage	95
3.15.1. Construction Impacts.....	97
3.15.2. Operational Impacts	98
3.15.3. Postulated Accidents.....	99
3.16. Transportation of Radioactive Materials	99
3.17. Decommissioning.....	101
4.0 LIST OF PREPARERS	103
4.1. NEPA Project Management	103
4.2. Other Contributors.....	103
5.0 DISTRIBUTION OF DRAFT AND FINAL SEIS.....	109
5.1. List of Agencies, Organizations, and Persons to Whom Copies of the Draft or Final SEIS Were Sent and to Whom E-links Were Provided	109
5.2. DSEIS Press Release	115
5.3. Information Open House Paid Advertisement	116
5.4. Information Open House Handout	117
6.0 SUPPORTING INFORMATION	121
6.1. Literature Cited.....	121
6.2. Index.....	126

LIST OF APPENDICES

Appendix A – Summary of Previous Hydrothermal Impact Studies.....	129
Appendix B – NPDES Flow Diagram	135
Appendix C – Aquatic Ecology Supporting Information	139
Appendix D – Response to Comments.....	157

LIST OF TABLES

Table S-1.	Summary of Direct, Indirect, and Cumulative Environmental Effects From Completion of WBN Unit 2	2
Table 1-1.	Environmental Reviews and Documents Pertinent to Watts Bar Nuclear Plant Unit 2	6
Table 1-2.	Effect of WBN Unit 2 on TVA Delivered Cost of Power	17
Table 2-1.	Summary of Direct, Indirect, and Cumulative Environmental Effects From Completion of WBN Unit 2	29
Table 3-1.	NPDES Temperature Limits for WBN Outfalls to the Tennessee River	35
Table 3-2.	Estimated Hydrothermal Conditions for Release From Watts Bar Dam	38
Table 3-3.	Estimated Hydrothermal Conditions for Thermal Effluent From Outfall 101 With Unit 1 Operation	39
Table 3-4.	Estimated Hydrothermal Conditions for Thermal Effluent From Outfall 101 With Unit 1 and Unit 2 Operation	40
Table 3-5.	Estimated Hydrothermal Conditions for Thermal Effluent From Outfall 113 With Unit 1 Operation	41
Table 3-6.	Estimated Hydrothermal Conditions for Thermal Effluent From Outfall 113 With Unit 1 and Unit 2 Operation	42
Table 3-7.	Predicted SCCW Impact on WBN Operation	44
Table 3-8.	History of Betz Chemical Treatment of Raw Water at WBN 1996-Present Chemicals	47
Table 3-9.	History of Nalco Chemical Treatment of Raw Water at WBN 1996-Present	47
Table 3-10.	Potential Chemical Discharge to NPDES Outfalls at WBN	50
Table 3-11.	History of Other Chemical Treatment of Raw Water at WBN 2006-Present	51
Table 3-12.	State-Listed Plant Species Reported From Within 5 Miles of the Proposed Project in Rhea County, Tennessee	60
Table 3-13.	Severe Accident Annual Risks	74
Table 3-14.	Public Water Supplies Within a 50-Mile Radius Downstream of WBN	79
Table 3-15.	Estimated Recreational Use of Tennessee River Within a 50-Mile Radius Downstream of WBN	79
Table 3-16.	WBN Total Annual Discharge-Liquid Waste Processing System for Two-Unit Operation	80
Table 3-17.	Watts Bar Nuclear Plant Doses From Liquid Effluents per Unit for Year 2040	84
Table 3-18.	Comparison of Estimated Annual Liquid Releases and Resulting Doses per Unit at WBN	84
Table 3-19.	Receptors from Actual Land Use Survey Results Used for Potential Gaseous Releases From WBN Unit 2	86
Table 3-20.	WBN Total Annual Gaseous Discharge Per Operating Unit (curies/year/reactor)	87
Table 3-21.	WBN Doses From Gaseous Effluent For Unit 2 Without Tritium Production for Year 2040	89

Completion and Operation of
Watts Bar Nuclear Plant Unit 2

Table 3-22.	Comparison of Estimated Annual Airborne Releases and Resulting Doses	90
Table 3-23.	Estimated Population Doses From Operation of Watts Bar Nuclear Plant.....	90
Table 3-24.	Maximum Anticipated Two-Unit Annual Solid Radwaste to be Processed.....	95
Table 3-25.	Data for Number of ISFSI Casks Determination	96
Table 3-26.	ISFSI Construction for Watts Bar Nuclear Plant Unit 1 as Compared to Construction of Both Units 1 and 2	97
Table 3-27.	ISFSI Operation for Watts Bar Nuclear Plant Unit 1 as Compared to Operation of Both Units 1 and 2.....	99
Table C-1.	Total Numbers and Percent Composition of Fish Eggs and Larvae Collected During 1976-1985, 1996, and 1997 in the Vicinity of Watts Bar Nuclear Plant	141
Table C-2.	Scoring Results for the 12 Metrics and Overall Reservoir Fish Assemblage Index for Chickamauga Reservoir, 2005.....	150
Table C-3.	Recent (1993-2005) RFAI Scores Developed Using the RFAI Metrics Upstream and Downstream of Watts Bar Nuclear Plant	151
Table C-4.	Individual Metric Ratings and the Overall Benthic Community Index Scores for Watts Bar Forebay and Sites Downstream of Watts Bar Nuclear Plant, Watts Bar and Chickamauga Reservoirs, November 2005	152
Table C-5.	Recent (1994-2005) Benthic Index Scores Collected as Part of the Vital Signs Monitoring Program at Watts Bar Reservoir – Transition and Forebay Zone Sites (Upstream) and Chickamauga Reservoir Inflow (Upstream) and Transition (Downstream) Sites.....	153
Table C-6.	Sensitive Aquatic Animal Species Known to Occur in the Watts Bar Dam Tailwaters Within 10 Miles of the Watts Bar Nuclear Plant.....	154
Table C-7.	Results of Recent Mussel Surveys (1983-1997) Within 2 River Miles Downstream From Watts Bar Dam, Tennessee River Mile 529.9 to 527.9	155

LIST OF FIGURES

Figure 1-1.	Location of Watts Bar Nuclear Plant	2
Figure 1-2.	Unit 2 Site Plan.....	3
Figure 1-3.	Actual and Forecast Net System Requirements	13
Figure 1-4.	2008 Estimated Capacity by Fuel Type	13
Figure 1-5.	2013 Estimated Capacity by Fuel Type	14
Figure 1-6.	2008 Estimated Generation by Fuel Type.....	16
Figure 1-7.	2013 Estimated Generation by Fuel Type.....	17
Figure 2-1.	Components of Watts Bar Nuclear Plant Heat Dissipation System	22
Figure 2-2.	Schematic of Current Configuration of Watts Bar Nuclear Plant Supplemental Condenser Cooling Water System.....	25
Figure 3-1.	Mixing Zone for Outfall 101	36
Figure 3-2.	Mixing Zones for Outfall 113	36
Figure 3-3.	Measured Temperatures for Outfall 113 Effluent and Bottom of Mussel Relocation Zone	43
Figure 3-4.	Location of Mussel Sanctuary in Chickamauga Reservoir Below Watts Bar Dam	58
Figure 3-5.	Archaeological Avoidance Area Within the Area of Potential Effect	63
Figure 3-6.	Pathways to Man Due to Releases of Radioactive Material	78
Figure 3-7.	Plant Liquid Effluent Pathways and Release Points	82
Figure 3-8.	Watts Bar Nuclear Plant Liquid Radwaste System	83
Figure 3-9.	Watts Bar Nuclear Plant Gaseous Effluent Release Points.....	88
Figure 3-10.	Liquid Radwaste Processing System – Simplified Flow Diagram for Tritiated Water	92
Figure 3-11.	Liquid Radwaste Processing System – Simplified Flow Diagram for Nontritiated Water	93

Page intentionally blank

ACRONYMS, ABBREVIATIONS, AND SYMBOLS

°C	Degree Celsius
°F	Degree Fahrenheit
±	Plus or Minus
γ	Gamma Radiation
β	Beta Radiation
§	Section
1972 FES	<i>Final Environmental Statement, Watts Bar Nuclear Plant Units 1 and 2 (TVA 1972)</i>
1978 NRC FES	<i>Final Environmental Statement Related to the Operation of Watts Bar Nuclear Plant Units 1 and 2 NUREG-0498 (NRC 1978)</i>
1995 FSER	<i>Final Supplemental Environmental Review, Operation of Watts Bar Nuclear Plant (TVA 1995b)</i>
1995 NRC FES	<i>Final Environmental Statement Related to the Operation of Watts Bar Nuclear Plant Units 1 and 2, NUREG-0498 (NRC 1995a)</i>
AEC	Atomic Energy Commission
APE	Area of Potential Effect
ASME	American Society of Mechanical Engineers
B/CTP	Biocide/Corrosion Treatment Plan
BFN	Browns Ferry Nuclear Plant
BMPs	Best Management Practices
C&I	Commercial and Industrial
CCS	Component Cooling Water System
CCW	condenser cooling water
CD	Compact Disc
CDWE	Condensate Demineralizer Waste Evaporator
CFR	Code of Federal Regulation
cfs	cubic feet per second
Ci	Curies
CLWR	Commercial Light Water Reactor
CLWR FEIS	<i>Final Environmental Impact Statement for the Production of Tritium in a Commercial Light Water Reactor (DOE 1999)</i>
CTBD	Cooling Tower Blow Down
DAW	Dry Active Waste
DMR	Discharge Monitoring Report
DOE	U.S. Department of Energy
DOI	U.S. Department of Interior
DSEP	Detailed Scoping, Estimating, and Planning
EA	Environmental Assessment
e.g.	Latin term, <i>exempli gratia</i> , meaning “for example”
EPRI	Electric Power Research Institute
EPZ	Emergency Planning Zone

ERCW	Essential Raw Cooling Water
et al.	Latin term, <i>et alii</i> (masculine), <i>et aliae</i> (feminine), or <i>et alia</i> (neutral), meaning “and others”
ETA	Monoethanolamine
etc.	Latin term <i>et cetera</i> , meaning “and other things” “and so forth”
FES	Final Environmental Statement
FEIS	Final Environmental Impact Statement
FRP	Flood Risk Profile
FEA	Final Environmental Assessment
FSEIS	Final Supplemental Environmental Impact Statement
FSAR	Final Safety Analysis Report
FSER	Final Supplemental Environmental Review
FONSI	Finding of No Significant Impact
ft²	Square Feet
gpm	Gallons per Minute
GWh	Gigawatt Hour
Hg	mercury
HPA	Habitat Protection Area
HSP	High Stress Polymer
i.e.	Latin term, <i>id est</i> , meaning “that is”
IMP	internal monitoring point
IPEEE	Individual Plant Examination for External Events
IRP FEIS	<i>Energy Vision 2020 - Integrated Resource Management Plan and Final Programmatic Environmental Impact Statement (TVA 1995a)</i>
IPS	Intake Pumping Station
ISFSI	Independent Spent Fuel Storage Installation
kV	Kilovolt
kW	Kilowatt
LP	Lined Pond
LRW	Liquid Radwaste
LVWTP	Low Volume Waste Treatment Pond
Max	Maximum
MIC	Microbiologically Induced Corrosion
Min	Minimum
MPC	Multipurpose Canister
mrem	millirem
mrad	millirad
MRZ	Mussel Relocation Zone
msl	Mean Sea Level
MVA	Megavolts-Ampere
MW	Megawatt
MWh/year	Megawatt Hours per Year
N/A	Not Applicable

NEI	Nuclear Energy Institute
NEPA	National Environmental Policy Act
NHPA	National Historic Preservation Act
No(s).	Number(s)
NO_x	Nitrogen Oxide
NPDES	National Pollutant Discharge Elimination System
NRC	U.S. Nuclear Regulatory Commission
NRHP	National Register of Historic Places
NRI	Nationwide Rivers Inventory
NUREG	U.S. Nuclear Regulatory Commission Regulatory Guidance Document
pCi/L	Picocuries per Liter
PMF	Probable Maximum Flood
PMP	Probable Maximum Precipitation
ppm	parts per million
PSAR	Preliminary Safety Analysis Report
Radwaste	Radioactive Waste
RCS	Reactor Coolant System
RCW	Raw Cooling Water
Region	TVA Power Service Area
RFAI	Reservoir Fish Assemblage Index
RHP	Runoff Holding Pond
ROD	Record of Decision
ROS	Reservoir Operations Study
ROS FEIS	<i>Reservoir Operations Study Final Programmatic Environmental Impact Statement</i> (TVA 2004a)
RV	recreational vehicle
SCCW	Supplemental Condenser Cooling Water
SEIS	Supplement Environmental Impact Statement
SEPA	Southeastern Power Administration
SFP	Spent Fuel Pool
SGB	Steam Generator Blowdown
SQN	Sequoyah Nuclear Plant
SHPO	State Historic Preservation Officer
SRDS	Solid Radwaste Disposal System
SO₂	Sulfur Dioxide
TBD	To Be Determined
TBSS	Turbine Building Station Sump
TCA	Tennessee Code Annotated
Tenn.	Tennessee
TPC	Tritium Production Core
TRM	Tennessee River Mile
TRO	Total Residual Oxidant
TVA	Tennessee Valley Authority

Completion and Operation of
Watts Bar Nuclear Plant Unit 2

ULP	Unlined Holding Pone
U.S.	United States
USEPA	U.S. Environmental Protection Agency
USFWS	U.S. Fish and Wildlife Service
WAW	Wet Active Waste
WET	Whole Effluent Toxicity
WBF	Watts Bar Fossil Plant (also known as Watts Bar Steam Plant)
WBH	Watts Bar Hydro Plant
WBN	Watts Bar Nuclear Plant
WMA	Wildlife Management Area
YHP	Yard Holding Pond

CHAPTER 1

1.0 PURPOSE OF AND NEED FOR ACTION

1.1. The Decision

The Tennessee Valley Authority (TVA) operates the largest public power system in the country. Demand for electricity in the TVA power service area has grown at an average rate of 2.4 percent per year for the past 15 years. In 2005, demand for electricity from the TVA system twice exceeded the previous all-time high demand (peak demand) on the system. Although this high level of load growth is expected to slow somewhat, TVA anticipates having to add additional baseload capacity to its system within the next decade to meet growing demand. At the same time, TVA is interested in reducing fossil-fuel emissions and lowering the delivered cost of power. The proposal under consideration by TVA is to help meet the demand for power resulting in a need for additional baseload capacity on the TVA system and to maximize the use of existing assets by completing and operating Watts Bar Nuclear Plant (WBN) Unit 2 alongside its sister unit, WBN Unit 1, which has been operating since 1996. This proposed action does not include producing tritium for the U.S. Department of Energy (DOE) at WBN Unit 2.

The purpose of this final supplemental environmental impact statement (FSEIS) is to inform decision makers and the public about the potential for environmental impacts that would be associated with a decision to complete and operate WBN Unit 2 concurrently with Unit 1. This document supplements the original 1972 final environmental statement (FES) titled *Final Environmental Statement, Watts Bar Nuclear Plant Units 1 and 2* (hereafter referred to as the 1972 FES) for the plant and updates pertinent information discussed and evaluated in the related documents identified below. In doing so, TVA updates the need for power analysis and information on existing environmental, cultural, recreational, and socioeconomic resources, as appropriate. TVA is also conducting a detailed, scoping, estimating, and planning (DSEP) study to evaluate the cost and schedule for completing WBN Unit 2. TVA will use information from the DSEP and this FSEIS process to make an informed decision about the proposed completion of WBN Unit 2.

1.2. Background

WBN is located in Rhea County on 1700 acres at the northern end of Chickamauga Reservoir about 8 miles from Spring City, Tennessee (see Figure 1-1). It is adjacent to the TVA Watts Bar Dam Reservation at Tennessee River Mile (TRM) 528 on the western shore of Chickamauga Reservoir. The plant currently has one Westinghouse pressurized-water reactor with a capacity of 1167 megawatts (MW)—enough electricity to daily supply about 650,000 homes. With the exception of the completion of Unit 2, the remainder of WBN facilities were developed as planned in the 1972 FES, with the addition of training facilities. Other changes have occurred since the 1995 supplemental environmental review (TVA 1995b). The tentative site plan, with a complete listing of existing and proposed buildings is shown in Figure 1-2. Although the exact location of the new facilities is not firm, the area to be disturbed is not expected to change. The extent of the area that is expected to be disturbed during the completion of WBN Unit 2 is shaded grey.

Completion and Operation of
Watts Bar Nuclear Plant Unit 2

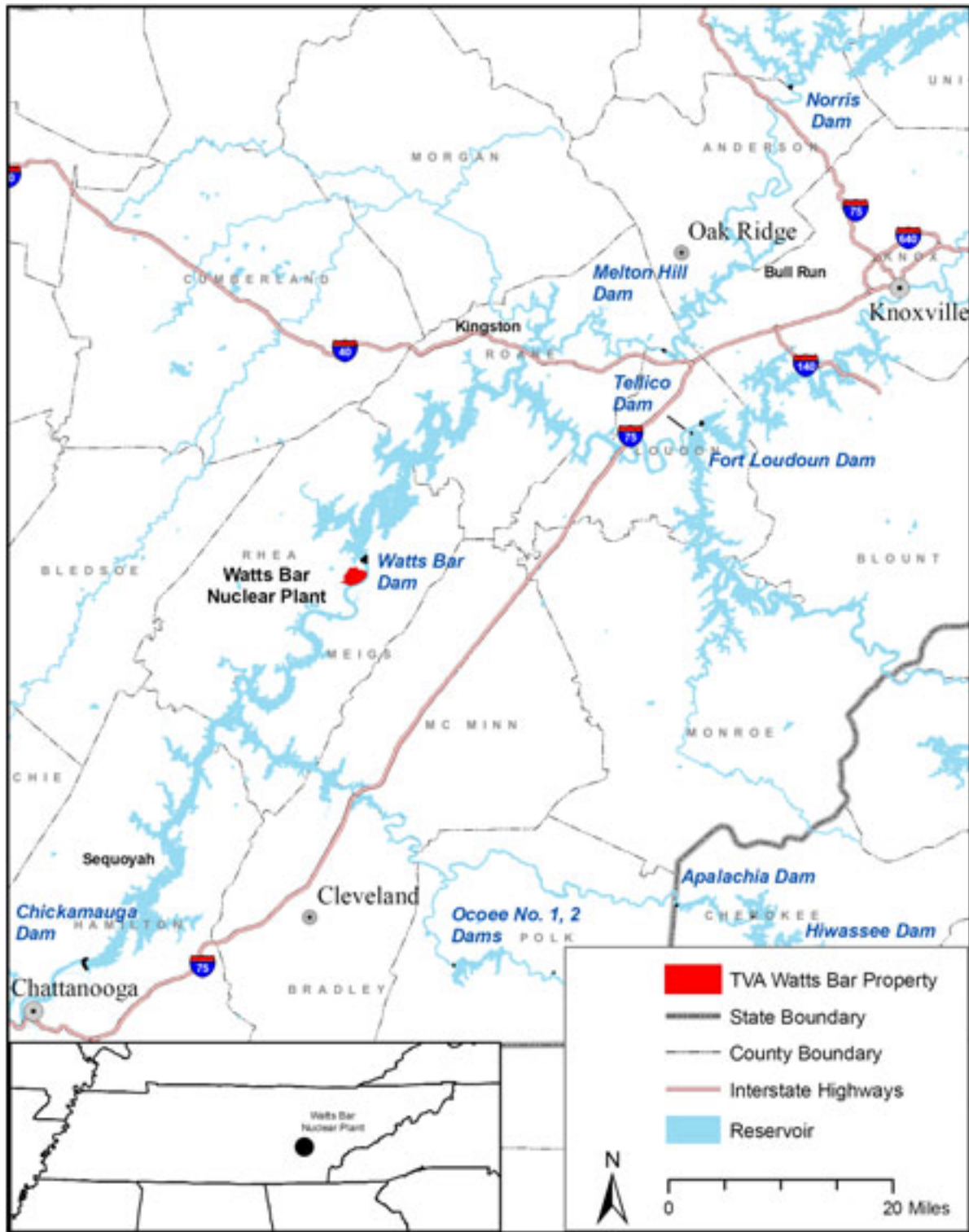

Figure 1-1. Location of Watts Bar Nuclear Plant

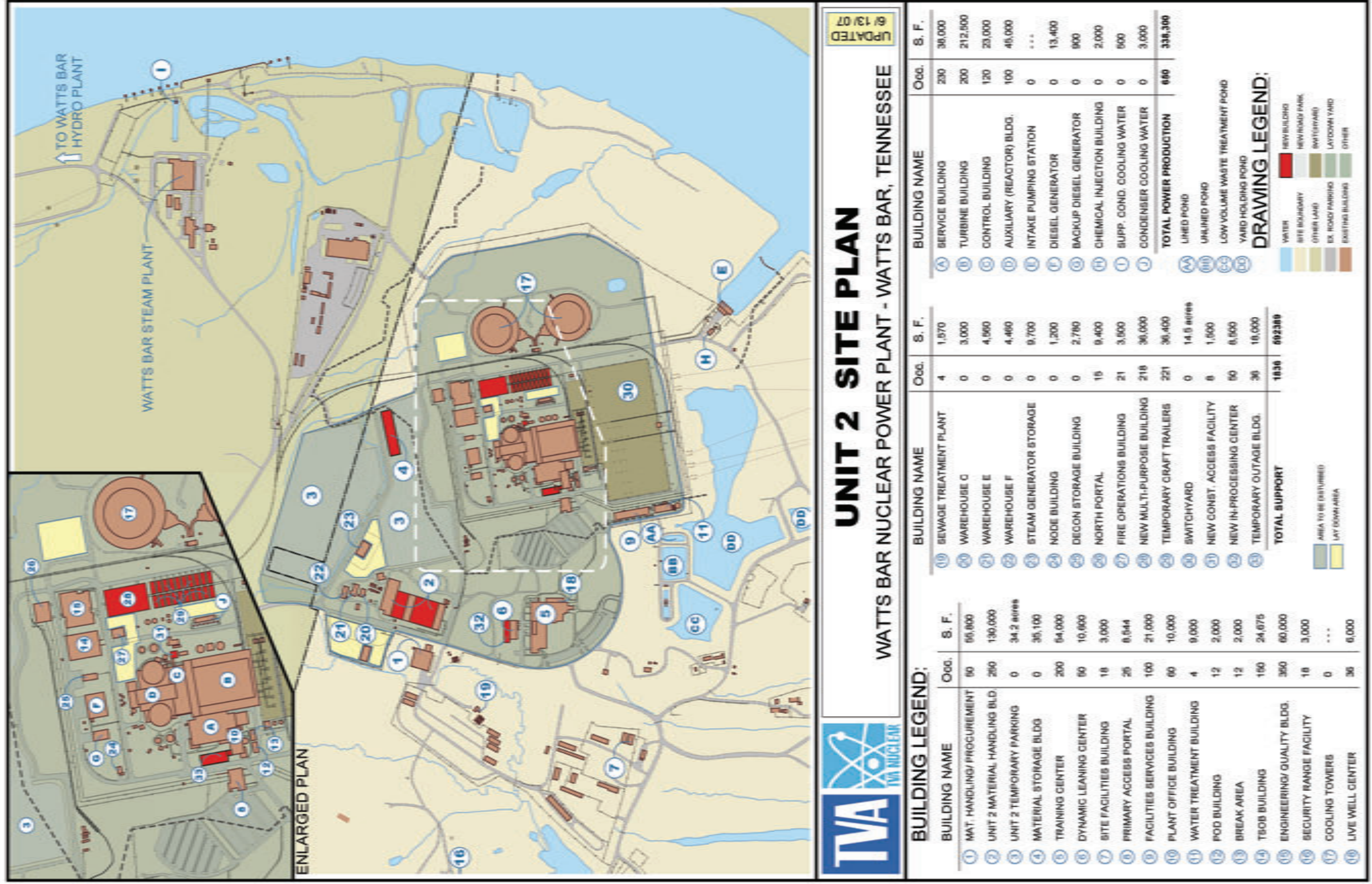

Figure 1-2. Unit 2 Site Plan

The Atomic Energy Commission (AEC) issued construction permits (now the responsibility of the U.S. Nuclear Regulatory Commission [NRC]) for the two-unit, 2540 MW plant in January 1973, and TVA began construction in the spring. TVA applied to the NRC (the agency that superseded the AEC) for operating licenses in 1976. Licensing of the plant was delayed due to new safety requirements following the 1979 accident at Three Mile Island, a number of other site-specific construction concerns, and a decline in the need for power following the Arab oil embargo of the 1970s. During the NRC's operating license application review, construction of WBN Unit 1 was 85 percent complete, and Unit 2 was 80 percent complete. In 1985, TVA halted construction activities for WBN in order to address regulatory concerns. In 1995, TVA decided to defer completion of WBN Unit 2 (see the discussion of TVA 1995a in Section 1.3).

To improve operation of WBN Unit 1, a supplemental condenser cooling water (SCCW) system was installed in the late 1990s. The SCCW enabled generation from Unit 1 to be increased. At the request of DOE, WBN Unit 1 began producing tritium in 2003 to help meet national defense needs. In 2006, four steam generators associated with operation of WBN Unit 1 were replaced to maintain full generation capability. Environmental reviews for these and other actions are listed in Table 1-1. TVA still holds a valid construction permit for the completion of WBN Unit 2. Over time, components from WBN Unit 2 have been used at TVA's WBN Unit 1, Sequoyah, and Browns Ferry Nuclear Plants.

If TVA decides to complete construction of WBN Unit 2, TVA would first notify the NRC of its intention to recommence construction. The next step, expected months later, would be to apply to NRC for an operating license. This would occur while completion of the unit was still ongoing. The application process includes preparation of a Final Safety Analysis Report (FSAR) and an Environmental Report. NRC is expected to conduct its own environmental review prior issuing an operating license.

TVA is the nation's largest public power provider and is completely self-financed. TVA provides power to 62 large industries and federal facilities as well as 158 power distributors that serve approximately 8.7 million consumers in seven southeastern states. TVA currently has about 35,000 MW of dependable generating capacity (winter net) on its system. This capacity consists of 3 nuclear plants, 11 coal-fired plants, eight combustion-turbine plants, 29 hydroelectric dams, one pumped-storage facility, one wind turbine energy site, and one methane-gas co-firing facility. More than 60 percent of TVA's installed generating capacity is from coal, almost 30 percent is from nuclear, and the remainder is produced by hydro, combustion turbines, and renewable energy resources turbines.

1.3. Other Pertinent Environmental Reviews and Tiering

Over 15 environmental reviews, studies, and white papers have been prepared for action related to the construction and operation of WBN. The following describes some of the more pertinent documents, and Table 1-1 provides a more complete listing of relevant environmental documents. As appropriate, TVA incorporates by reference, utilizes, tiers from, and updates information from these earlier plant-specific analyses for the present FSEIS.

The TVA 1972 FES reviewed the potential environmental and socioeconomic impacts of constructing and operating the two-unit plant. TVA updated the 1972 FES in November 1976 and submitted additional environmental information and analyses to NRC in an environmental information supplement in 1977 (TVA 1977a). In December 1978, NRC issued its FES, NUREG-0498, related to the licensing of the two-unit plant.

Table 1-1. Environmental Reviews and Documents Pertinent to Watts Bar Nuclear Plant Unit 2

Document Type	Title	Date
FES	<i>Final Environmental Statement, Watts Bar Nuclear Plant Units 1 and 2 (TVA 1972)</i>	November 1, 1972
Other	<i>Environmental Information, Watts Bar Nuclear Plant Units 1 and 2 (TVA 1976a) [Note: This is a supplement to the 1972 FES]</i>	November 18, 1976
Other	<i>Environmental Information, Supplement No. 1, Responses to NRC Questions for Operating License State Environmental Review, Watts Bar Nuclear Plant Units 1 and 2 (TVA 1977a)</i>	May 1977
FES	<i>Final Environmental Statement Related to the Operation of Watts Bar Nuclear Plant Units 1 and 2 NUREG-0498 (NRC 1978)</i>	December 1, 1978
EA	<i>Environmental Assessment for Low-Level Radwaste Management, Watts Bar Nuclear Plant (TVA 1980a)</i>	July 11, 1980
Draft FEIS	<i>Watts Bar Waste Heat Park, Rhea County, Tennessee, Volumes 1 and 2 (TVA 1980b)</i>	October 20, 1980
EA	<i>Proposed Incinerator for Burning Low-Level Radioactive Waste (TVA 1989)</i>	January 1989
FES Review	<i>Review of Final Environmental Statement, Watts Bar Nuclear Plant, Units 1 & 2 (TVA 1993a)</i>	August 1, 1993
FES	<i>Final Environmental Statement Related to the Operation of Watts Bar Nuclear Plant, Units 1 and 2, Supplement No. 1, NUREG-0498, Docket Nos. 50-390 and 50-391 (NRC 1995b)</i>	April 1, 1995
FSEIS	<i>Final Supplemental Environmental Review, Operation of Watts Bar Nuclear Plant (TVA 1995b)</i>	June 1, 1995
FSEIS Adoption	<i>Adoption of Final Supplemental Environmental Impact Statement, 60 FR 35577 (TVA 1995c)</i>	July 10, 1995
ROD	<i>Record of Decision - Operation of Watts Bar Nuclear Unit 1 (TVA 1995d)</i>	August 9, 1995
FEIS and ROD	<i>Energy Vision 2020 – Integrated Resource Management Plan and Final Programmatic Environmental Impact Statement (TVA 1995a)</i>	December 21, 1995

Table 1-1 (continued)

Document Type	Title	Date
EA Adoption/ FONSI	<i>Lead Test Assembly Irradiation and Analysis, Watts Bar Nuclear Plant, Tennessee, and Hanford Site, Richland, Washington - Adoption of U.S. Department of Energy Environmental Assessment and Finding of No Significant Impact, EA-1210 (TVA 1997)</i>	August 19, 1997
FEA/FONSI	<i>Final Environmental Assessment Related to the Watts Bar Nuclear Plant Supplemental Condenser Cooling Water Project (TVA 1998a)</i>	August 20, 1998
FEA/FONSI	<i>Low Level Radioactive Waste Transport and Storage, Watts Bar and Sequoyah Nuclear Plants (TVA 1999a)</i>	November 22, 1999
FEIS	<i>Final Environmental Impact Statement for the Production of Tritium in a Commercial Light Water Reactor (DOE 1999)</i>	March 1999
ROD/ Adoption	<i>Record of Decision and Adoption of the Department of Energy Final Environmental Impact Statement for the Production of Tritium in a Commercial Light Water Reactor (TVA 2000)</i>	May 5, 2000
FEIS/ROD	<i>Reservoir Operations Study Final Programmatic Environmental Impact Statement and Record of Decision (TVA 2004a)</i>	May 19, 2004
FEA/FONSI	<i>Watts Bar Nuclear Plant Unit 1 Replacement of Steam Generators, Rhea County, Tennessee (TVA 2005a)</i>	April 7, 2005
FEA/FONSI	<i>Watts Bar Nuclear Plant to Spring City Sewer Pipeline Project (TVA 2005b)</i>	May 1, 2005

In 1993, TVA conducted a thorough review of the TVA and NRC documents to determine if additional environmental review was needed to inform decision makers about whether to complete WBN Units 1 and 2. The 1993 TVA review, focusing on 10 sections of the earlier documents, concluded that neither the plant design nor environmental conditions had changed in a manner that materially altered the environmental impact analysis set forth in the earlier FES. In 1994, TVA provided additional analyses and information in support of NRC's preparation of an FES supplementing its 1978 FES related to the operation of WBN Units 1 and 2. That supplemental FES, issued by NRC in 1995, similarly concluded that there were no significant changes in the potential environmental impacts from the proposed completion of WBN Units 1 and 2. In July 1995, following independent review of the adequacy of the analyses and a new analysis of the need for additional power, TVA adopted the 1995 NRC FES supplement. In August 1995, TVA issued a record of decision (ROD) confirming the agency decision to complete WBN Unit 1. In 1998, TVA prepared an environmental assessment (EA) and finding of no significant impact (FONSI) for a project to

provide SCCW to WBN for the purpose of increasing power generation from Unit 1 that was constrained by cooling tower performance.

In the late 1990s, TVA participated as a cooperating agency with DOE on an environmental review evaluating the production of tritium at one or more commercial light water reactors (CLWR) to ensure safe and reliable tritium supply for U.S. defense needs. In March 1999, the Secretary of DOE designated the TVA WBN and Sequoyah Nuclear Plant (SQN) as the preferred alternative for tritium production in the *Final Environmental Impact Statement for the Production of Tritium in a Commercial Light Water Reactor* (DOE 1999), hereafter referred to as the CLWR FEIS. DOE issued a ROD in May 1999. TVA issued its own notice of adoption and ROD for the CLWR FEIS in May 2000, and tritium production began at WBN Unit 1 in 2003. (The proposed action here does not include producing tritium at WBN Unit 2.) The CLWR FEIS also includes pertinent information on spent nuclear fuel management, health and safety, decommissioning, and other topics.

In December 1995, TVA completed a comprehensive environmental review of alternative means of meeting demand for power on the TVA system through the year 2020 (TVA 1995a). This review was in the form of a final environmental impact statement (FEIS) titled *Energy Vision 2020 – Integrated Resource Management Plan and Final Programmatic Environmental Impact Statement* (hereafter referred to as IRP FEIS). Deferral and completion of WBN Unit 2 were embedded among the suite of alternatives evaluated in this FEIS. To address future demand for electricity, TVA decided to rely on a portfolio of energy resource options, including new generation and conservation. Because of uncertainties about performance and cost, however, completion of WBN Unit 2 was not included in the portfolio of resource options selected by TVA for implementation. Keeping open alternatives that would meet the goals and objectives of the IRP FEIS, TVA did, however, reserve for future consideration completing WBN Unit 2. This consideration is now occurring. The present FSEIS updates analyses in the previous environmental reviews and tiers from the IRP FEIS, particularly utilizing the analysis of energy resource options therein.

In the IRP FEIS, TVA made conservative assumptions about the expected performance of its nuclear units (i.e., the capacity factor—roughly how much a unit would be able to run). This capacity factor was used in conducting the economic analyses of nuclear resource options. TVA nuclear units, consistent with nuclear industry performance in the U.S., now routinely exceed this earlier assumed capacity factor, which changes the earlier analyses for WBN Unit 2, and is being taken into account in the current consideration of completing the unit (see Section 1.6, Need for Power). The present environmental review and any resulting decisions will serve to update any pertinent portions of and related decisions made after completing the IRP FEIS.

In February 2004, TVA issued its *Reservoir Operations Study Final Programmatic Environmental Impact Statement* (hereafter referred to as the ROS FEIS) evaluating the potential environmental impacts of alternative ways of operating the agency's reservoir system to produce overall greater public value for the people of the Tennessee Valley (TVA 2004a). That FEIS review addressed the water supply needs of TVA generating facilities, such as WBN, and compliance with limits of their NPDES and other permits. A ROD for the ROS FEIS was subsequently issued in May 2004. The assumptions for reservoir operations resulting from the ROS FEIS review and the cumulative effects analysis as it pertains to the operation of WBN are incorporated by reference in the present evaluation.

1.4. Scoping and Draft SEIS Review

1.4.1. Scoping

As described above, WBN Units 1 and 2 have received extensive environmental review over the past 30 years. Additional public scoping is not required for an SEIS [40 Code of Federal Regulations (CFR) § 1502.9(c)(4)]. However, extensive internal scoping by a TVA interdisciplinary team included compilation and review of the documents listed in Table 1-1, the TVA 2002 FSEIS for operating license renewal of the Browns Ferry Nuclear Plant (BFN), and information about the proposed completion of WBN Unit 2. Based on that review, it was determined that the following topics should be addressed in this update of the environmental record for the completion of WBN Unit 2:

- Surface Water and Groundwater Quality
- Aquatic Ecology
- Terrestrial Ecology
- Threatened and Endangered Species
- Wetlands
- Natural Areas
- Cultural Resources (Archaeological and Historical)
- Socioeconomics
- Environmental Justice
- Land Use
- Floodplains and Flood Risk
- Seismic Effects
- Nuclear Plant Safety and Security
- Radiological Effects
- Radiological Waste
- Spent Fuel Storage
- Transportation of Radioactive Materials
- Decommissioning

Other areas of potential impact were found to have been adequately evaluated in the previous environmental reviews, and no substantive changes to either proposed activities or design, or additional information relevant to the particular environmental concern, were discovered. Impacts from transmission line construction, operation, and maintenance are addressed in the 1972 FES and the *Final Supplemental Environmental Review, Operation of Watts Bar Nuclear Plant*, hereafter referred to as 1995 FSER (final supplemental environmental review). Since no changes in or additions to transmission lines are planned as a result of completion of WBN Unit 2, no further discussion of these impacts are included in this document. Upgrade of the WBN temporary site power distribution system is under consideration. While not a requirement for or part of the proposal to complete and operate WBN Unit 2, the potential impacts associated with upgrading the site power distribution system are discussed in this document.

1.4.2. Draft SEIS Review

The DSEIS for the Completion and Operation of Watts Bar Nuclear Plant Unit 2 was posted on TVA's website on March 29, 2007. A notice of availability was published in the *Federal Register* on March 30. In addition, the document was mailed or e-mailed to the state, local and Federal agencies and organizations list in Section 5.1. A press release describing opportunities for commenting on the DSEIS, including an information open house, was

issued on April 6 (see Section 5.2). Paid advertisements for the open house (see Section 5.3) were run in the following newspapers:

Friday, April 6, 2007 and Monday, April 16, 2007

Chattanooga Times Free Press

Knoxville News-Sentinel

Athens Daily Post Athenian

Cleveland Daily Banner

Monroe County Advocate/Democrat

Wednesday, April 11, 2007

Dayton Herald News

The Bradley News Weekly

An information open house was held in the gymnasium of the Rhea County High School in Evansville, Tennessee from 4:30 to 8:00 pm eastern daylight time. Twenty seven people registered. During the open house, comments on the draft could be made orally to a court reporter, on the internet by computer, or by written comment form. A copy of the open house handout is included in Section 5.4.

TVA accepted comments on the DSEIS from March 30 until May14, 2007. A total of 1258 comments were received. These consisted of 1229 form letters, 22 other comments from the public, and 7 letters from state and federal agencies. Many of the commenters opposed nuclear power and voiced general concerns about the use of nuclear power. Many comments focused on water quality, the safety of nuclear power, spent fuel, radwaste, alternative sources of energy and conservation, and socioeconomic impacts. Some comments raised concerns about, the cost of power and the adjacent mussel sanctuary. A listing of all comments received, by author and TVA's responses to these comments are included in Appendix D. Comments were responded to directly or by revising sections of the SEIS.

1.5. Environmental Permits and Approvals

Existing WBN environmental permits and approvals are described in Table 1-1 in Section 1.3 of TVA's 1995 FSEIS (TVA 1995b). Construction and operation of WBN Unit 2 may require that some of these permits be amended and additional approvals obtained. For example, the air emission operating permit for the plant might have to be amended to add any new emission sources associated with WBN Unit 2 such as emergency diesel generators. Because WBN Unit 1 is already operating and construction activities associated with WBN Unit 2 are expected to occur primarily within existing structures, there should be few additional permits and approvals required. TVA would work with pertinent regulatory agencies to obtain any necessary amendments and approvals. NRC approval to operate the unit would have to be obtained.

Federal and state environmental agencies continue to conduct periodic inspections to verify that WBN Unit 1 complies with all permit and applicable requirements. If WBN Unit 2 is completed, these inspections will include Unit 2.

The 1972 FES describes the initial involvement of other state and federal agencies in consideration of the construction of WBN Units 1 and 2. At that time, state and regional input was coordinated via A-95 clearinghouses. In 1995, TVA consulted with the U.S. Fish and Wildlife Service (USFWS) and jointly with NRC submitted a biological assessment. In

response, USFWS issued a biological opinion. Correspondence with the USFWS was included as Appendix D in NRC 1995b. Further coordination with USFWS occurred in the preparation of the subsequent environmental reviews pertaining to WBN Units 1 and 2 listed in Section 1.3. Based on the updated analysis of potential impacts on federally listed as threatened or endangered species from construction and operation of WBN Unit 2, no effects on listed species are expected. TVA has communicated supporting information about this determination to USFWS and additional information is included in TVA's response to a comment letter received from the Office of Environmental Policy and Compliance, U.S. Department of Interior (DOI).

This FSEIS also documents TVA's compliance with Section 106 of the National Historic Preservation Act (NHPA) (Section 3.7).

1.6. Need for Power

Electricity is a just-in-time commodity. It cannot be stored in meaningful amounts, so the resources needed to produce the amount of electricity demanded from a system must be available when the demand is made. If the demand cannot be met, reductions and curtailments in service—i.e., brownouts or blackouts—result. One of TVA's most important responsibilities is ensuring that it is able to meet the demand for electricity placed on its power system. Thousands of businesses, industries and public facilities, and literally millions of people depend on TVA to get this right.

To meet this responsibility TVA forecasts the future demand and the need for additional generating resources in the region it serves. Today's load forecasting methodologies are superior to those of two decades ago because they recognize that demand for electricity is a derived demand determined by (1) the level of economic activity, (2) the price of electricity, (3) the prices of available alternative fuels, and (4) increased efficiencies from new conservation and technology. Further, today's methodologies utilize an explicit treatment of uncertainty with ranges of inputs to investigate alternative load-growth scenarios.

A need for power exists when future demand exceeds the capabilities of currently available and future planned generating resources. Because planning, permitting, and construction of new generating capacity typically takes many years, TVA must make decisions to build new generating capacity well in advance of the actual need. This section updates the need for power analysis in Section 1 of the 1995 FSER and shows the circumstances when demand exceeds supply and additional baseload generation is needed. TVA's method of forecasting demand and its analysis of a large number of generating and demand-side management resources (options) that could meet forecasted demand are addressed in the IRP FEIS.

In addition to meeting increased power demand, adding to nuclear capacity improves the diversity of resources on the TVA system, thereby reducing the risks inherent with any particular kind of resource; provides added flexibility to reduce emissions from TVA fossil generating plants by reducing generation from those plants; and potentially reduces the cost of power to customers. Future power demand, supply, and capacity for the TVA system and the resulting need for additional power are discussed below.

Description of the TVA Power System

TVA serves an 80,000-square-mile region encompassing almost all of the state of Tennessee and portions of the states of Kentucky, Mississippi, Alabama, Georgia, North Carolina, and Virginia. The major load centers are the cities of Memphis, Nashville, Chattanooga, and Knoxville, Tennessee, and Huntsville, Alabama. The population of the service territory in 2006 is estimated to be 8,836,484. TVA serves 158 municipal and cooperative customers as their sole supplier of electricity, and 61 directly served industries as retail customers. The total number of businesses and residential customers served in 2006 was 4,394,604. TVA supplies almost all electricity needs in Tennessee, 32 percent in Mississippi, 27 percent in Alabama, and 26 percent in Kentucky. Its contribution to the electricity needs in Virginia, North Carolina, and Georgia, respectively, is 3 percent or less.

Power Demand

The primary factor affecting the demand for power in the TVA power service area (Region) is economic growth. Historically, regional economic growth has been more dependent on manufacturing than the U.S. average. This trend is forecast to continue as the Region benefits from its favorable location at the center of the auto industry in the southern U.S., even though job growth in the manufacturing sector is declining in the Region. Population growth is expected to be strong. Most migration to the Region is still due to job opportunities. Some of this population growth results from jobs in retail businesses, serving the existing population, but a growing part is "export" services that are "sold" to areas outside the Region. Notable examples are corporate headquarters such as Nissan in Nashville and Service Master in Memphis, but also include such industries as the still-growing music business centered in Nashville. In addition, the Region has become an attractive locality to retirees looking for a moderate climate and a more affordable area than traditional retirement locations. The increase in retiree population results in additional population growth in service industries and the people needed to work in them.

The expected load forecast for TVA retail customers reflects historical sales and announced plans of customers to use electric power. The actual and forecast net system requirements for TVA, including residential, distributor-served commercial and industrial (C&I), and direct-served industrial customers are shown in Figure 1-3. Net system requirements grew at an average rate of 2.4 percent from 1990 through 2006, driven by distributor-served residential and C&I load growth.

The forecast period is shown for three alternative load-growth scenarios. TVA traditionally plans toward the medium-load forecast, but the low and high forecasts help inform power supply decision-making. Under the medium forecast, it is assumed that demand and energy will grow at a rate based on expected economic growth.

The assumptions underlying the load forecasts for higher or lower loads are the same as for the medium-load forecast except for economic growth: Demand and energy for the high-load forecast grow at a rate based on high economic growth and for the low-load forecast at a rate based on low economic growth.

Net system requirements are projected to grow at an average rate of 2.0 percent through 2010 for the medium-load forecast, but grow at a lower rate in the long term as compared to the recent past. Direct-served industrial growth is to be assumed flat.

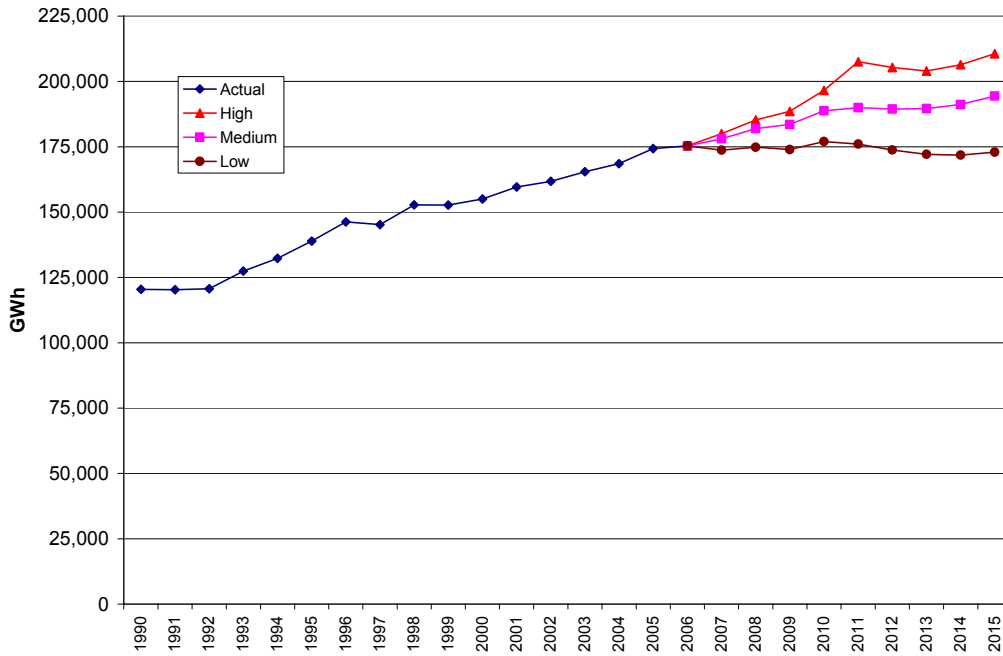

Figure 1-3. Actual and Forecast Net System Requirements

Power Supply

TVA’s existing and planned power supply consists of coal, nuclear, hydro, gas, additional renewable resources, and purchases. Planned power supplies include resources under contract or projects contemplated by TVA as future capacity additions or uprates. The estimated capacity of the TVA portfolio by fuel type in 2008 and 2013 are shown in Figures 1-4 and 1-5, respectively. No long-term fuel availability problems are anticipated that would limit the capability of resources included in the capacity plan. Purchases and interruptible load are considered a type of capacity because they are available to respond to demand.

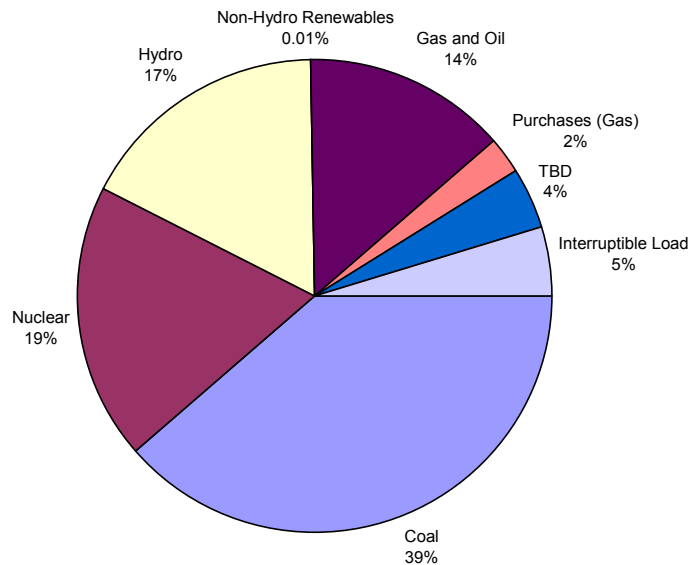

Figure 1-4. 2008 Estimated Capacity by Fuel Type

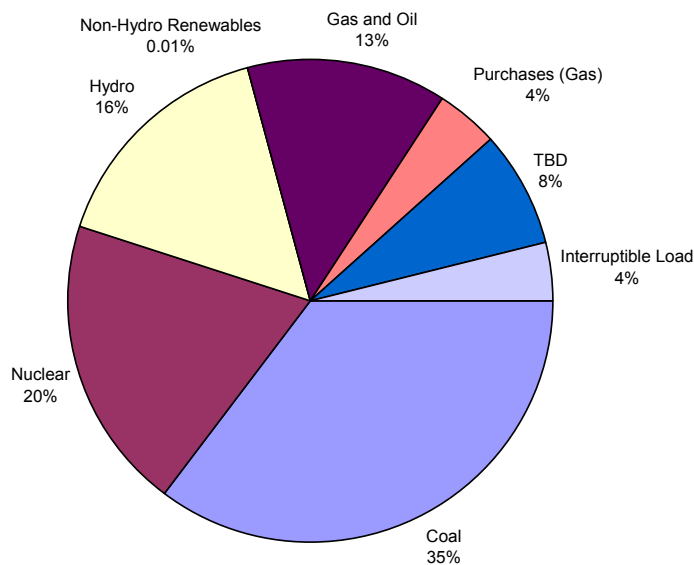

Figure 1-5. 2013 Estimated Capacity by Fuel Type

Capacity additions to TVA-owned resources are also included in Figures 1-4 and 1-5. For analytical purposes, these include additions that are currently being implemented such as the restart of TVA’s BFN Unit 1 and the uprate of all three units at the plant, a mix of energy resource options from the portfolio of options in TVA’s IRP FEIS (TVA 1995a) that could be implemented, and completion of WBN Unit 2. Demand-side management options are also included in this mix. None of TVA’s existing resources are expected to be retired during the period analyzed here. Hydro capacity includes both conventional hydro and pumped storage. Additional renewable resources include solar, wind, and landfill gas resources. Only the portion of these resources that are likely to be generating during the peak period hours are counted toward capacity needs. Small changes in the capacity of coal units are included in the capacity plan to account for changes in TVA’s plan to meet emissions requirements. These changes include changes in fuel source and operation of air pollution control equipment that affect the net generating capability of the units. The TVA nuclear units have an assumed capacity factor of approximately 90 percent going forward—a significant improvement over the assumed capacity factor in the IRP FEIS (67 percent).

The capacity plan shows a long-term baseload capacity purchase (Red Hills Power Plant); long-term intermediate capacity purchase (hydro marketed by the Southeastern Power Administration [SEPA]¹ and hydro owned by Tapoco, a subsidiary of the Aluminum Company of America), and short-term intermediate and peaking capacity purchases from the market. Interruptible load contracts are included and counted toward reserve requirements.

The amount of generating capacity, the source for which is yet to be determined (TBD), increases between 2008 and 2013. During this period, the need for capacity of any type (baseload, intermediate or peaking) increases by 3800 MWs in that five year period; .

¹ A substantial amount of the electricity provided by SEPA comes from the hydroelectric units at Wolf Creek Dam (Lake Cumberland) on the Cumberland River system. Output from these units is expected to be reduced substantially while repairs to the dam are made, an effort that could take 7 to 10 years. This increases the need for additional capacity in the intermediate term.

Completing WBN Unit 2 with its 1150 MWs would only meet part of this projected need.

The TVA Board recently announced in the form of a strategic plan that TVA would place greater emphasis on increasing energy efficiency and energy conservation and more use of renewable energy resources to help meet and reduce future demand. These actions would help address the projected shortfall that remains even if WBN Unit 2 is completed.

Need for New Capacity

TVA is a dual-peaking system with high demand occurring in both the summer and winter months. However, the forecasted peak load or the highest demand placed on the TVA system is always projected to be in the summer months. A need for power exists if TVA has insufficient capacity to meet the peak demand in the summer, or if the resources in the capacity plan cannot provide enough energy to meet the load (Figure 1-3). Baseload capacity is the primary type of capacity used to meet energy needs. This generation is expected to be available and operate during almost all hours. Peaking capacity is generation that is expected to be available and operate during peak demand periods on a system. Baseload generation typically has lower operating costs, such as nuclear generation and larger coal units. Hydro generation has the lowest operating costs and is generally reserved for peak demand periods or to help regulate the system due to the limitations on water supply.

To assure that enough capacity is available to meet the peak demand in the summer, additional resources or planning reserves are required. Planned reserves in the utility industry are typically 12-18 percent, depending on the age of current resources. TVA targets a planned reserve of 15 percent, which includes 10 percent long-term reserves and 5 percent operating reserves.

TVA determines how much of the total capacity need should be baseload generation by comparing the expected generation of available resources to net system requirements (Figure 1-3) to determine whether there is a surplus or deficit of energy². If there is a deficit of energy, then some of the additional capacity needs should be met with new baseload resources. Any additional capacity needs would be intermediate or peaking resources.

Additional baseload generation is needed by 2010 under the medium- and high-load forecasts. Under the low-load forecast, bringing on WBN Unit 2 in 2013 provides additional fuel diversity, operating flexibility, and a lower delivered cost of power. The addition of WBN Unit 2 in 2013 would improve the diversity of resources serving TVA customers and reduce the cost of power. It would provide TVA the flexibility of relying less on its coal-fired generation. TVA has installed and is continuing to install pollution control devices on its coal-fired generating units to reduce the emissions of sulfur dioxide (SO₂), nitrogen oxides (NO_x), and mercury (Hg) to respond to emissions reduction requirements. Increasing nuclear generation beyond what may be needed to meet near-term load growth would give TVA the flexibility to reduce generation from higher-cost coal generation and reduce emissions this way, thereby reducing these emissions depending on actual demand in the future and the performance of TVA's other resources.

² Baseload capacity is needed if baseload demand exceeds baseload capacity. Baseload demand is that portion of forecasted net system requirements occurring at loads equal to or less than average load (U.S. Nuclear Regulatory Commission, Environmental Standard Review Plan, NUREG 1555, October 1999). Baseload capacity consists of all resources with expected capacity factors greater than 65 percent.

The estimated percentage of generation by fuel type for 2008 and 2013, are shown in Figures 1-6 and 1-7, respectively. The capacity mix that would result in this generation was shown previously in Figures 1-4 and 1-6 by fuel type. The capacity percentage by fuel type differs from the generation percentage by fuel type because actual operation of installed capacity (how much is generated from a unit) depends on a number of different variables, including fuel costs, variable operating and maintenance expenses, and the type of demand being met (e.g., peak load, baseload). TVA (and other utilities) employs sophisticated production cost models that consider all of these variables in order to simulate future demands on each type of generation, each plant, and each unit on the TVA system. Coal resources produce 54 percent of the simulated generation in 2008, but only 52 percent of generation in 2013 after WBN Unit 2 begins operation. Nuclear generation increases from 29 percent in 2008 to 33 percent in 2013. Resources that are using or are likely to use gas or oil³ produce 4 percent to 5 percent of generation, depending on the year.

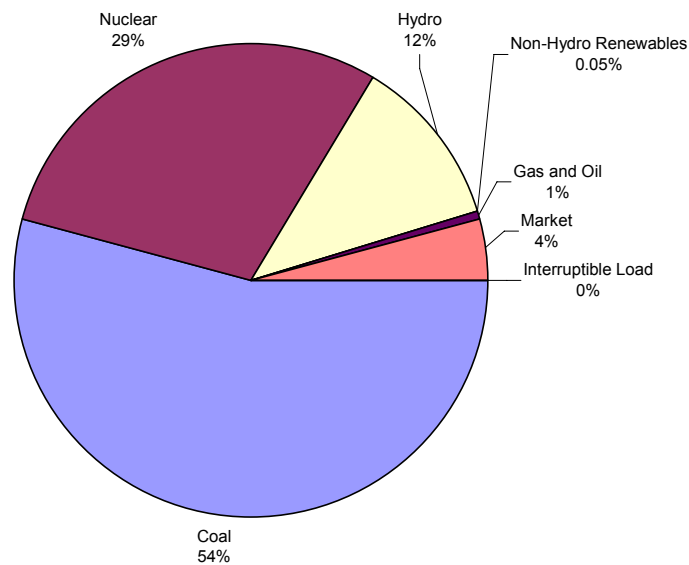

Figure 1-6. 2008 Estimated Generation by Fuel Type

³ Assumed to include gas and oil and market, in Figure 1-3.

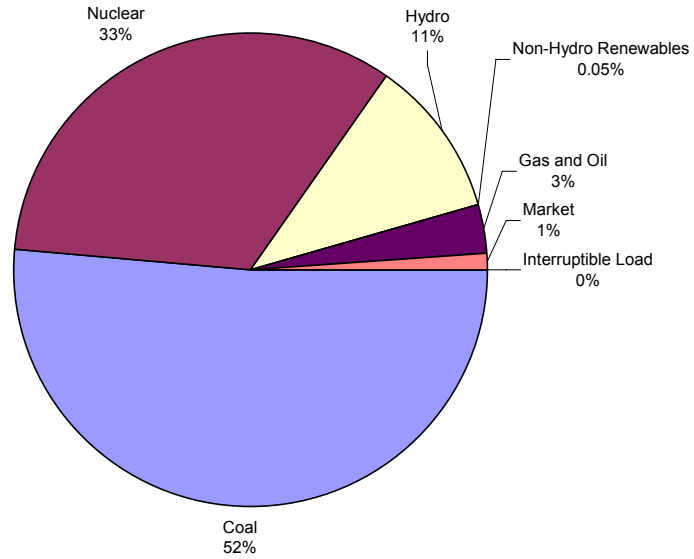

Figure 1-7. 2013 Estimated Generation by Fuel Type

The effect of the addition of WBN Unit 2 on TVA delivered cost of power in 2013-15 is shown in Table 1-2. The addition of WBN Unit 2 is projected to reduce the delivered cost of power an average of 3.7 percent in 2013-15.

Table 1-2. Effect of WBN Unit 2 on TVA Delivered Cost of Power

	2013	2014	2015
Without WBN Unit 2 (cents/kWh)	4.89	4.93	5.08
With WBN Unit 2 (cents/kWh)	4.73	4.74	4.88
Change (cents/kWh)	-0.16	-0.19	-0.20
Percent Change	-3.3%	-3.9%	-3.9%

Page intentionally blank

CHAPTER 2

2.0 ALTERNATIVES INCLUDING THE PROPOSED ACTION

TVA considered a number of alternatives to constructing and operating WBN, including the No Action Alternative, in its 1972 FES. In December 1995, TVA issued the IRP FEIS (TVA 1995a). As described in Section 1.3 of this document, the IRP FEIS analyzed a portfolio of options for meeting TVA's future power needs that were derived from the best strategies identified during a two-year process with extensive public input. The environmental impacts of energy resource options were evaluated as part of the IRP FEIS. Because of uncertainties about performance and cost, however, completion of WBN Unit 2 was not included in the portfolio of resource options selected by TVA for implementation. Keeping open alternatives that would meet the goals and objectives of the IRP FEIS, TVA did, however, reserve for future consideration completing WBN Unit 2. TVA is now, in the context of this SEIS process, reconsidering completion of WBN Unit 2. This is in large part due to the actual operating experience with TVA's nuclear plants which have achieved a capacity factor of 90 percent, a substantial improvement compared to what was projected in the IRP FEIS (67 percent) (see Section 1.3). In tiering off the original 1972 FES, the IRP FEIS, and the balance of the environmental record pertinent to WBN, this FSEIS identifies no new alternatives or resource options beyond those already addressed in those documents.

The need for power analysis presented in Chapter 1 shows how completion of WBN Unit 2 would help TVA meet expected demands for increased baseload power and the need for greater operating reserves. WBN Unit 2 completion would also provide more flexibility to reduce fossil plant emissions and lower the cost of power. To meet the need for additional baseload power and the objective of maximizing the use of exiting assets, TVA is proposing to follow through with its original plans to complete WBN Unit 2.

2.1. Proposed Action

TVA proposes to complete WBN Unit 2 with minimal changes to the original plant design. Unit 2 was about 80 percent complete when construction work halted in 1985. However, a substantial amount of equipment/components—including reactor coolant pump, rotating assemblies, valves, instrumentation—have been removed over the years to support WBN Unit 1 and SQN Units 1 and 2. As a result of this and the corrective actions that must be implemented similar to those performed on Unit 1, WBN Unit 2 is now considered approximately 60 percent complete.

A removed equipment log has been maintained on WBN Unit 2, and limited scope walkdown conducted in 2005 showed good correlation between the removed equipment and the log. The existing equipment in the reviewed systems was found to be in good condition, and the hardware installation appeared to be 75 to 80 percent complete. A limited documentation review of randomly selected records for two systems (chemical and volume control system and main feedwater) demonstrated a high correlation of retrievable records for completed fieldwork, design, and procurement. In 2000, the preventive maintenance program for Unit 2 equipment was reduced in scope when it was determined to be more cost effective to replace or refurbish equipment should Unit 2 be completed. While some equipment continues to be maintained, most Unit 2 mechanical and electrical

systems are not currently in the preventive maintenance program. This equipment may need to be replaced or refurbished if Unit 2 is completed.

The following list of actions required to complete WBN is based on a 2005 cost estimate. The DSEP, which is being prepared concurrently with this environmental review, will provide a more detailed and complete description of what is required to complete Unit 2. If the DSEP results in operational or design changes not reviewed in this document, a supplemental environmental review would be prepared to address potential environmental impacts of those changes.

- Upgrade to incorporate major capital projects implemented on Unit 1 since commercial operation to achieve fidelity between Units 1 and 2, with the exception of modifications made to enable tritium production at WBN Unit 1. Currently, there are no plans for Unit 2 to produce tritium.
- Refurbishment of major nuclear steam supply systems equipment such as reactor coolant pumps and control and instrumentation.
- Replacement of transmission system equipment utilized for Unit 2 operation such as switchyard breakers.
- Upgrade of Unit 2 cooling tower consistent with the upgrades completed on the Unit 1 cooling tower.
- Refurbish major turbine generator equipment such as bearings, rotors, and electrical generator.
- Replacement of equipment that has been removed to support WBN Unit 1 or SQN operations such as feed pump turbine and feedwater flow regulating valves.
- Replacement of various obsolete instrumentation and control systems for both the nuclear steam supply systems and secondary plant operation such as turbine supervisory and core power monitors.
- Construction of minor facilities required to support construction.
- Code inspection, documentation and reconciliation to meet American Society of Mechanical Engineers (ASME) III standards. (WBN is an ASME III designed and constructed plant.)

Since the reactor containment, turbine, control buildings, and cooling towers have already been constructed, no new major construction activities would be required to complete Unit 2. No new water intakes or outfalls are needed. As described above, the majority of work would involve refurbishment or replacement of interior controls and equipment. All new support buildings (the tentative locations of which are shown in red on Figure 1-2) and laydown areas would be constructed inside the existing vehicle barrier wall. Temporary parking areas would be established on the site perimeter on previously disturbed land. Equipment, materials, and supplies for Unit 2 completion would be delivered by truck to the plant site. BMPs for erosion and sedimentation and noise and dust control would be used during construction. A general permit for stormwater associated with construction activity

would be applied for is cumulative disturbances of greater than or equal to 1 acre occurs. All construction waste would be recycled or disposed of in an appropriate, licensed landfill.

Four steam generators dedicated to the operation of WBN Unit 1 were replaced in fall 2006 after 10 years of operation. At this time, there are no plans to replace the installed steam generators for Unit 2 during completion of the unit. Chemistry control and removal of copper tubing from other secondary heat exchangers are expected to maximize the life of the existing WBN Unit 2 steam generators.

Construction activities are expected to last approximately five years. A design and construction workforce of up to 3000 is anticipated, comprised of approximately 1500 manual craft workers, 400 nonmanual craft workers, and 600 engineers. Additionally, TVA will hire approximately 200 staff augmentation contractors and an additional 120 TVA employees dedicated to completion of Unit 2. The workforce peak is expected in years 2 and 3 of construction. Accommodation of the construction workforce is discussed in Section 3.8 of this document.

2.2. Changes in Plant Design and Operational Systems Since 1995

Several changes have been made to plant design and operations since 1995, the most important of which was the addition of an SCCW system. As explained in the SCCW FEA (TVA 1998a), the SCCW system was added to WBN to improve plant performance. The changes to plant operations resulting from installation of the SCCW system are addressed here and in Section 3.1.1. Some changes also have been made to the systems and processes for handling liquid and solid radioactive waste and spent fuel. These changes are addressed in Sections 3.14 and 3.15.

2.2.1. Plant Water Use

In terms of basic sources, water use for WBN has not changed since the 1972 FES. Steam generator makeup water, service water, and condenser cooling water (CCW) are obtained from the Tennessee River. In the original configuration of the plant, all this water was obtained from an intake pumping station (IPS) located at TRM 528.0, about 1.9 miles below Watts Bar Dam. In 1999, the SCCW system was placed into service, which provides additional water by gravity flow from an intake structure located at TRM 529.9, immediately upstream of Watts Bar Dam. The locations of these water intakes are shown in Figure 2-1. Potable water continues to be obtained from groundwater supplies provided by a local utility, Watts Bar Utility District.

2.2.2. Heat Dissipation System

The major components of the WBN heat dissipation system are shown schematically in Figure 2-1. The original arrangement for dissipating waste heat at WBN, described in the 1972 FES, includes a closed-mode cooling system with one natural draft cooling tower per nuclear unit. With this arrangement, all water required for the plant cooling systems inside the reactor buildings and turbine building was to be obtained from the Tennessee River

Completion and Operation of
Watts Bar Nuclear Plant Unit 2

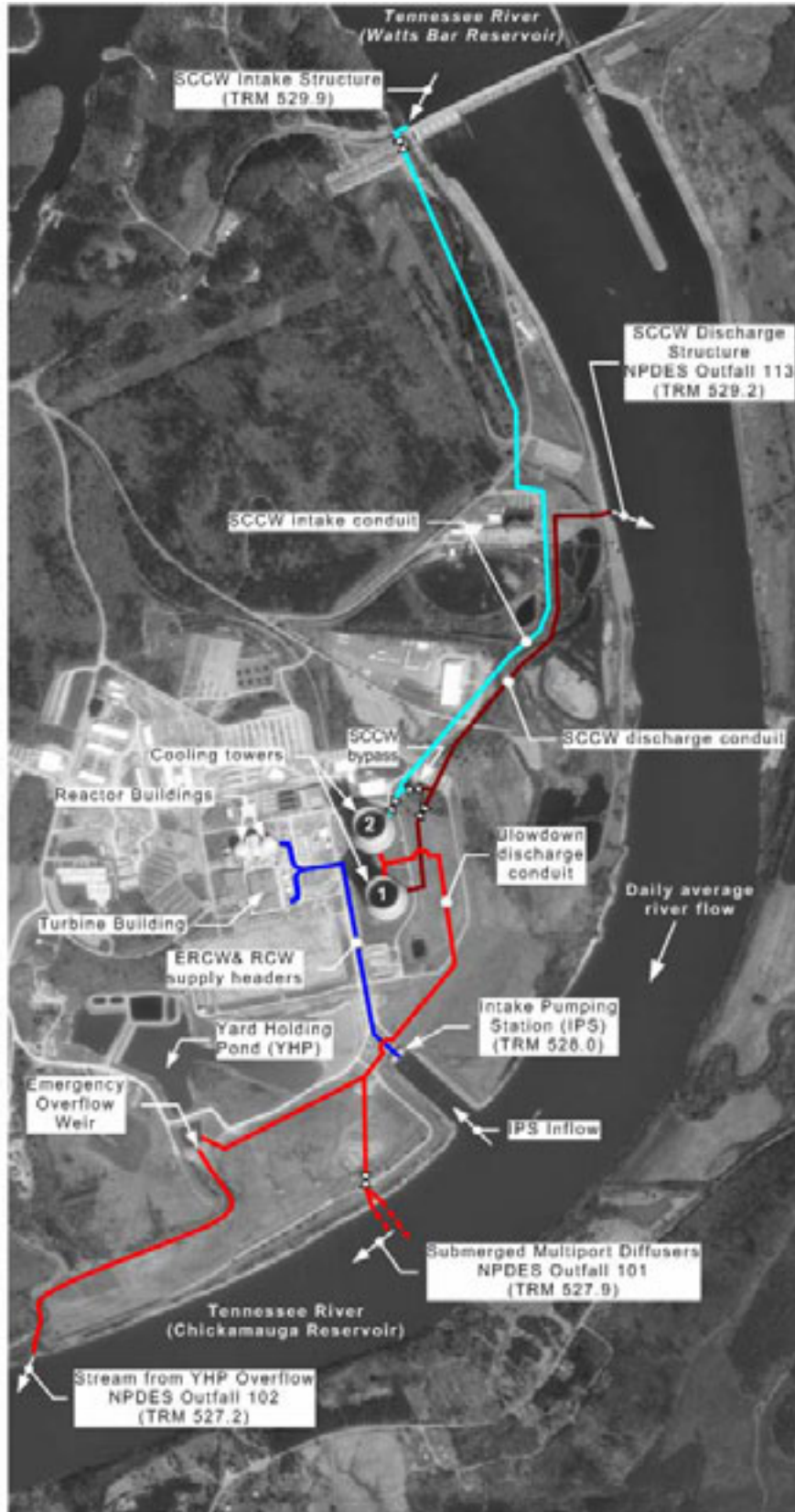

Figure 2-1. Components of Watts Bar Nuclear Plant Heat Dissipation System

by the IPS located at TRM 528.0. In the system, nearly all the waste heat created by the plant is dissipated in the atmosphere by the cooling towers. A small fraction of the waste heat is dissipated in the Tennessee River by the cooling tower blowdown. Cooling tower blowdown includes water that is continuously removed from the CCW system to control the level of dissolved solids in the system. At WBN, blowdown in the original system is returned to the Tennessee River through multiport bottom diffusers, located 2.0 miles below Watts Bar Dam at TRM 527.9. To provide adequate dilution of the plant effluent, discharge from the diffusers is permitted only when the release from Watts Bar Dam is at least 3500 cubic feet per second (cfs). To ensure this happens, an interlock is provided between the dam and WBN that automatically closes the diffusers when the flow from the hydroturbines at Watts Bar Dam drops below 3500 cfs. To provide temporary storage of water during these events, the blowdown discharge conduit also is connected to a yard holding pond. When the flow from Watts Bar Dam drops below 3500 cfs, thereby closing the diffuser valves, the blowdown is automatically routed to the yard holding pond. When hydro operations resume with releases of at least 3500 cfs, the interlock is “released” and the diffuser valves can be opened. When this occurs, the discharge from the diffusers would contain blowdown from the cooling towers and blowdown from the yard holding pond. To protect the site from the consequences of exceeding the capacity of the yard holding pond, an emergency overflow weir is provided for the pond, which delivers the water to a local stream channel that empties into the Tennessee River at TRM 527.2. The operation of Watts Bar Dam and the WBN blowdown system are very carefully coordinated to avoid unexpected overflows from the yard holding pond.

Previous studies estimated the average and maximum inflow for the IPS for the operation of both WBN units are expected to be about 107 (TVA 2007a) and 143 cfs (TVA 1977b), respectively. Experience with one unit operation (i.e., Unit 1) identifies the inflow for the IPS as about 80 cfs (Appendix B). For the original heat dissipation system, the maximum discharge from the plant diffusers due solely from blowdown from the cooling towers was expected to be about 50 cfs for the operation of one unit and 85 cfs for the operation of both units (TVA 1977b). For the case where the diffusers are discharging blowdown from both the cooling towers and the yard holding pond, the maximum flow is expected to be about 135 cfs for the operation of one unit and 170 cfs for the operation of both units (TVA, 1977b). In general, apart from unexpected emergency situations, the discharge from the overflow weir of the yard holding pond would be 0 cfs (for operation of one or both WBN units).

Prior to the startup of the plant, engineering studies predicted that the WBN cooling towers would not remove the desired amount of heat from the steam cycle, resulting in generation losses. This was confirmed by measurements after Unit 1 began commercial operation in 1996. Internal modifications were made to the Unit 1 Cooling Tower and the SCCW system was placed into service in July 1999. The basic components of the SCCW system are shown in Figure 2-1. A more detailed schematic is shown in Figure 2-2. The SCCW system withdraws water from the intake structure located immediately upstream of Watts Bar Dam at TRM 529.9, which formerly served the Watts Bar Fossil Plant (now retired). A new SCCW intake conduit was constructed between the fossil intake and the cooling tower basin for WBN Unit 2. To reach Unit 1, the SCCW flow passes through the Unit 2 cooling tower basin and mixes with the Unit 1 CCW flow through a gated opening added in the wall separating the Unit 1 and Unit 2 CCW intake channels. The temperature of the water in the SCCW system is usually lower than that provided by the Unit 1 cooling tower. In this manner, the SCCW flow reduces the temperature of the Unit 1 condenser flow and

enhances the performance of the steam cycle, reducing generation losses caused by the deficiency in the cooling tower design.

After passing through the condenser and cooling tower, the CCW flow ends up in the basin beneath the Unit 1 cooling tower. The cooling tower basin includes a side-channel weir to remove blowdown from the CCW system. Since the SCCW inflow exceeds the capacity of the Unit 1 blowdown conduits, the SCCW system also includes a separate side-channel weir in the Unit 1 cooling tower basin to deliver heated water back to the Tennessee River. The elevation and length of the SCCW side-channel weir was selected to preserve the design of the original blowdown system. In this manner, the amount of flow withdrawn from the Unit 1 cooling tower basin via the SCCW discharge conduit is roughly the same as that delivered to the plant by the SCCW intake conduit. This SCCW discharge conduit releases the SCCW effluent to the river through a discharge structure located at TRM 529.2, about 0.7 miles below Watts Bar Dam. As with the SCCW intake structure, the SCCW discharge structure formerly served the Watts Bar Fossil Plant. Since the SCCW system is operated by gravity flow, the amount of water entering and exiting the system depends on the elevation of the water surface behind Watts Bar Dam. Based on design computations, the flow through the SCCW system is not expected to exceed about 365 cfs (high pool behind Watts Bar Dam). Experience with one unit operation (i.e., Unit 1) identifies the average SCCW flow to be about 200 cfs (Appendix B).

The SCCW system was designed and constructed as a discretionary system. In this manner, the SCCW system has no significant impact on the original blowdown system, allowing the plant to operate with or without the SCCW system in service. If the SCCW system is in service, the fraction of waste heat dissipated in the Tennessee River can be higher than that of the original full, closed-mode operation. Control valves are provided in both the SCCW intake conduit and the SCCW discharge conduit to allow adjustment of the water level in the cooling tower basins and provide a proper balance of the flows entering and exiting the Unit 1 CCW system. Under certain conditions, releases from the SCCW discharge structure can approach environmental limits for the water temperature in the Tennessee River. To avoid exceeding these limits, the SCCW system includes a conduit with a control valve that allows part of the cool intake flow to bypass the plant and mix directly with the heated effluent in the discharge conduit. When there is a threat of exceeding the temperature limit in the river established by the plant's NPDES permit, the bypass conduit is opened to provide precooling of the effluent before it enters the SCCW discharge structure.

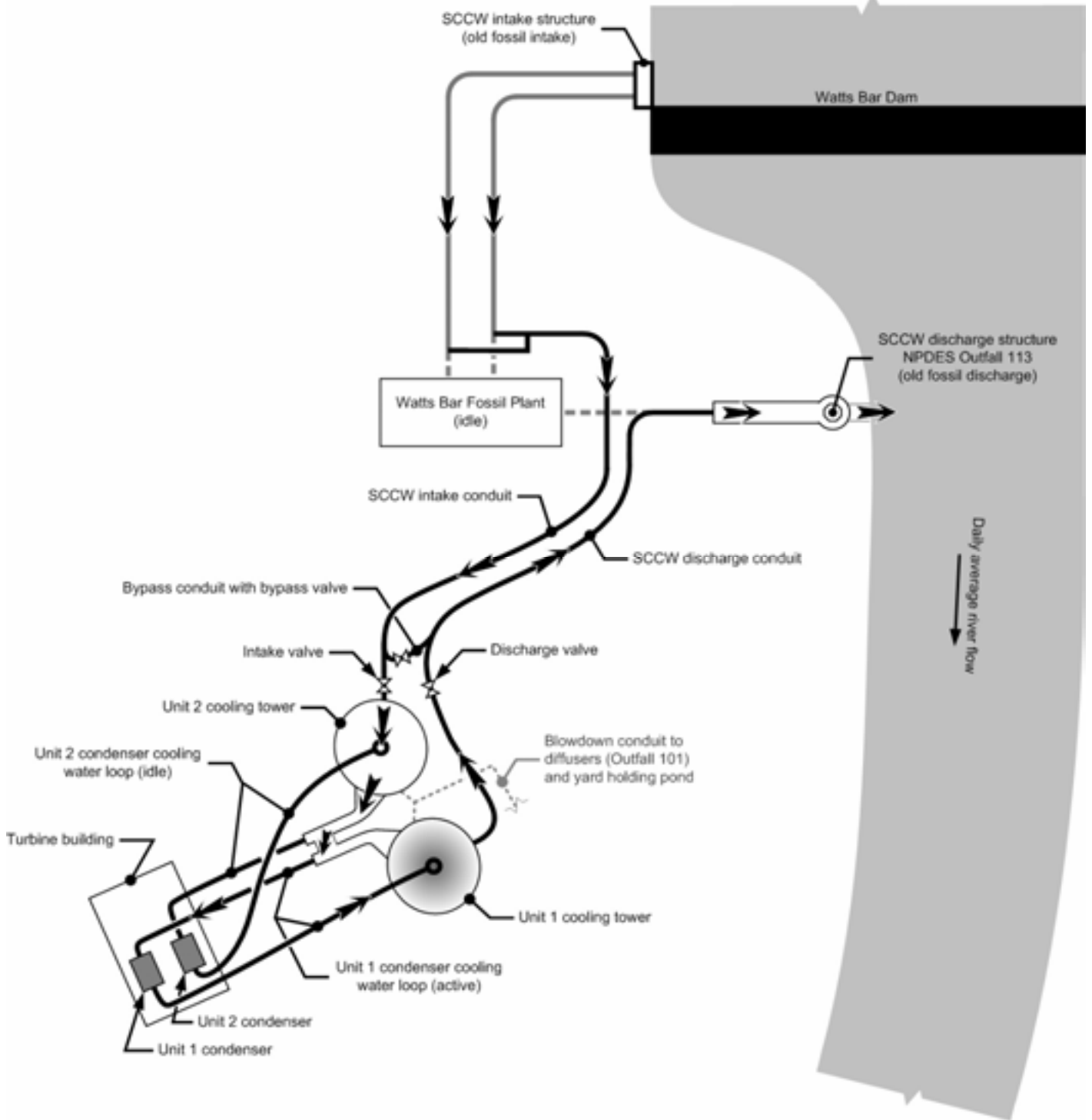

Figure 2-2. Schematic of Current Configuration of Watts Bar Nuclear Plant Supplemental Condenser Cooling Water System

If WBN Unit 2 is completed, the current plan is to supply the SCCW to both the Unit 1 and the Unit 2 CCW systems. In this manner, and with the SCCW system in operation, neither Unit 1 nor Unit 2 would be returned to the original full, closed-mode operation. Thus, Unit 1 and Unit 2 would include heat dissipation primarily to the atmosphere, and if the SCCW system is in service, Unit 1 and Unit 2 could include a sizable amount of heat dissipation to the Tennessee River. The hydrothermal analysis conducted to evaluate heat dissipation is described and potential impacts evaluated in Sections 3.1, 3.2, and 3.4.

The WBN NPDES permit, renewed in November 2004, identifies the diffuser discharge as Outfall 101 (TRM 527.9), the emergency overflow from the yard holding pond as Outfall 102 (TRM 527.2), and the discharge from the SCCW system as Outfall 113 (TRM 529.2). As emphasized above, the permit stipulates that discharge from Outfall 101 can occur only when releases from the Watts Bar Hydro Plant (WBH) are greater than 3500 cfs. When releases drop below 3500 cfs, the diffuser discharge for Outfall 101 is automatically suspended and blowdown flow is diverted to the yard holding pond. The discharge from Outfall 102 is very infrequent; whereas, the discharge from Outfall 113 is common throughout the year. Unlike Outfall 101, the operation of Outfall 102 and Outfall 113 do not require a minimum flow from WBH.

The NPDES permit of 1993 stipulated that TVA conduct temperature modeling studies to determine the appropriate daily average discharge temperature limit from Outfall 101 and Outfall 102. In response, TVA completed studies and reported the results to the state in December 1993. The report, titled *Discharge Temperature Limit Evaluation for Watts Bar Nuclear Plant*, recommended a daily average discharge temperature limit of 35 degrees Celsius (°C) (95 degrees Fahrenheit [°F]) for Outfall 101 (TVA 1993b). A recommendation also was provided for the size of the mixing zone for the discharge diffusers, providing ample space for the movement of fish in the river past the outfall. The studies and recommendations included the operation of one or both nuclear units at WBN. The recommendations were adopted by the permitting authority, as specified in the current NPDES permit, effective November 2004. The temperature for outfall 101 is measured by a continuous monitor in the blowdown conduit before the water enters the river. The current NPDES permit also specifies a discharge temperature limit of 35°C (95°F) for Outfall 102. Since discharge by the emergency overflow is infrequent, the temperature limit for Outfall 102 applies as a daily grab sample rather than a daily average value of continuous measurements. The TVA modeling studies demonstrated that outside of the recommended mixing zone, these discharge limits will ensure compliance with the State of Tennessee water quality standards for the protection of aquatic wildlife. These standards are as follows:

The receiving water shall not exceed (1) a maximum water temperature change of 3°C (5.4°F) relative to an upstream control point, (2) a maximum temperature of 30.5°C (86.9°F), except when upstream (ambient) temperatures approach or exceed this value, and (3) a maximum rate of change of 2°C (3.6°F) per hour outside of a mixing zone.

The same temperature standards also apply to Outfall 113 and are applied to assigned mixing zones for the safe passage of fish in the river. Outfall 113 also contains a temperature limit of 33.5°C (92.3°F) in the receiving stream bottom at the SCCW outlet (see Table 3-1). In contrast to Outfall 101 and Outfall 102, the standards for Outfall 113 are enforced by a combination of continuous instream temperature measurements, field tests, and routine model predictions.

2.3. Other Activities

WBN is the only TVA Nuclear power station that did not convert the temporary site power distribution system to a permanent system when it began operation. This system is old and many parts need upgrading or replacement. The temporary site power system is currently used by WBN Unit 1 to supply power to WBN support non-safety related functions including the wastewater treatment plant, offices and storage buildings and also serves as the power supply during outages. The distribution system consists of the substation in the old Watts Bar Fossil (WBF) switchyard and a 13 kilovolt (kv) line that goes to the Corridor Substation (commonly known as the "Corridor Sub"), located on the north side of WBN. The Corridor Sub includes two substations, the Corridor Substation and a Construction Power Substation.

Various proposal to upgrade to a permanent system have been under consideration for several years, but no decision has been made as to whether to proceed. Although WBN Unit 2 construction could benefit from the upgrade of the temporary site power distribution system, it is not a requirement to go forward with completion and operation of WBN Unit 2.

Currently, two options are currently under consideration for upgrading this distribution system.

Option 1- Under this option, TVA would abandon the existing substation at WBF and build a new 161-kv line and substation adjacent to the Corridor Sub. The new substation would occupy approximately a 100 square foot (ft²) area. Since space is limited in the the existing switchyard, this would entail expanding the substation foot print, possibly to the west. The new single circuit 161-kV transmission line would go from the new substation to the north and then northwest about 0.9 mile until it taps into the existing WBH- Spring City 161-kV Line near Crosby road. The tap point would consist of a tap structure and two 2000 amp sectionalizing switches. The new line would have a 100 to 150-foot right of way, a large portion of which would need clearing. The entire line would be on TVA property.

The new substation would include a new 161-13-kV 10 MVA transformer, two circuit switchers with isolation and bypass switches on the 161-kV side of the transformer, and one 13-kV breaker along with associated isolation and bypass switches. This breaker would attach to the existing 13-kV bus in the "Corridor" substation. Also, relaying protection would be installed for all new equipment in the new substation.

Option 2 – Under Option 2 TVA would build the new substation at the retired WBF, adjacent to the existing switchyard, tapping the existing WBHP-WBF 161-kV line for power supply. The new station would occupy approximately 100 ft². A tap structure or flying tap and a short span of line would be installed to connect to the new substation. No upgrade would be required to the existing 13 kv lines that bring power from WBF to the Corridor Sub.

The new substation would include a 161-13-kV 10 MVA transformer, two circuit switchers with isolation and bypass switches on the 161-kV side of the transformer, and one lowside breaker (13-kV) along with isolation & bypass switches. This breaker would attach to the existing 13-kV line that supplies the Corridor substation. Also, relaying protection would be installed for all the new equipment in the new substation.

The new substations and line connections described in Options 1 & 2 are not part of the proposed action in this SEIS, i.e. completion and operation of WBN Unit 2. However, because upgrade of the distribution system is anticipated some time in the future, the potential for cumulative impacts exists and is discussed below:

Wildlife Resources. Due to the extent of prior disturbance, there is a general lack of wildlife habitat at the project site and neither upgrade option would significantly degrade available wildlife habitat. The state-listed eastern hellbender, the federally listed bald eagle and the state-tracked osprey occur within 3 miles of WBN and the federally listed gray bat is known from Meigs County, Tennessee. As stated in Section 3.3.2, no suitable habitat for these species occurs at the project site. The implementation of either upgrade option in combination with Unit 2 completion would not result in cumulative effects for any of these species. Additionally, three heron colonies, but no caves had previously been located within 3 miles of sites for either power option. All of these heron colonies have moved because of pine beetle infestations, and the nearest colony is 4 miles away.

Plant Resources. Under Option 1, some disturbance of existing plant communities would occur during the construction of a new substation and new 161 kV power line. Even though clearing of vegetation would be necessary on a large portion of the proposed right-of-way, no uncommon terrestrial communities or otherwise unusual vegetation occur on the lands to be disturbed. Less disturbance of existing plant communities would occur under Option 2, which does not entail power line construction. No new infestations of exotic invasive plant species are expected as a result of the either alternative. In addition, no occurrences of federally listed as threatened or endangered or state-listed plant species are known on or immediately adjacent to the two proposed areas. No cumulative impacts to plant communities or to sensitive plant species from either option in combination with completion of Unit 2 are expected.

Aquatic Resources. No impacts to aquatic resources are anticipated under either option. Construction of facilities and associated lines would use BMPs to avoid or reduce potential impacts to streams and the reservoir. These BMP's are used routinely in the construction of TVA transmission line and distribution facilities and provide good protection for aquatic resources. Neither option is expected to affect any sensitive aquatic species or critical habitat.

Natural Area Resources. No Nationwide Rivers Inventory (NRI) streams or Wild and Scenic rivers are in the area. Five natural areas are in the vicinity of the proposed options. Natural areas within 3 miles of the proposed work described in Options 1 and 2 and the approximate mileage from the proposed work areas, respectively, are as follows: Chickamauga Reservoir State Mussel Sanctuary - 0.8 mile (0.4 mile), Chickamauga Shoreline TVA Habitat Protection Area - 1.0 mile (1.3 miles), Chickamauga State Wildlife Management Area Yellow Creek Unit - 1.0 mile (1.5 miles), Meigs County Park - 1.4 miles (1.0 mile), and Yuchi Wildlife Refuge at Smith Bend - 2.3 miles (3.0 miles). Because the distance from each option to natural areas is sufficient for the work proposed, no cumulative impacts from either option in combination with the completion of Unit 2 are anticipated. Additionally, both options are located on TVA property that is designated for power generation and where on-site development of power facilities and structures would be expected to occur.

Historic Resources. Both Options 1 and 2 have the potential to effect prehistoric and/or historic properties listed or eligible for listing in the National Register of Historic Places (NRHP). If TVA selected one of these options—or any other option that would involve construction of new facilities—TVA would comply with Section 106 of the National Historic Preservation Act (NHPA). As appropriate, this would involve consultation with the Tennessee State Historic Preservation Officer (SHPO) and Tribal Historic Preservation Officers. Potential impacts on cultural resources are not expected to be significant. Since no effect on historic resources are expected from the completion of WBN, no cumulative effects to these resources would be expected from section of either upgrade option

Visual Resources. Option 1 involves construction of additional transmission structures, substation components, and lines. The visual impact of such incremental changes may not be individually significant, but when additions are seen in combination with similar existing features, the impact could grow. This could result in a cumulative change in the visible landscape. The structural changes or additions required for Option 2 would be minimal and would not likely create a noticeable visual effect.

Based on this review, the potential for adverse cumulative affects would be small from either of these options in combination with the completion of WBN Unit 2 but more likely from Option 1 than Option 2. If and when TVA decides to upgrade the existing temporary site power distribution system at WBN, a more detailed environmental review will be conducted and further consideration given to the potential for cumulative effects. If adverse effects a identified, appropriate mitigation would be considered.

2.4. Summary of Environmental Effects

Table 2-1 provides a summary of the potential environmental effects from the proposed completion of WBN Unit 2, as updated by the present environmental review.

Table 2-1. Summary of Direct, Indirect, and Cumulative Environmental Effects From Completion of WBN Unit 2

Resource	Potential Environmental Effects
Surface Water Quality	Insignificant hydrothermal effects on near-field and far-field temperatures and on the operation of the supplemental condenser cooling water (SCCW), given compliance with National Pollutant Discharge System (NPDES) permit limits. Insignificant effects from raw water chemical treatment. Water intake would increase by 33 percent over present conditions but still would be within the original design basis of the plant for two-unit operation. A corresponding increase of essential raw cooling water and raw cooling water chemical additives of 33 percent would occur. Towerbrom treatment for Condensing Cooling Water (CCW) would increase 100 percent. These increases are not expected to affect compliance with existing NPDES effluent limitations that protect aquatic resources.

Table 2-1 (continued)

Resource	Potential Environmental Effects
Groundwater Quality	No impacts expected.
Aquatic Ecology	Since no construction activities would occur within 500 feet of the reservoir, all construction activities would be subject to appropriate BMPs to ensure that there are no impacts to surface water, intake flows would stay within the original design basis for operation of the two-units in closed cycle mode, and discharge changes would remain within existing NPDES limits. Any impacts to aquatic ecology, plankton, or aquatic communities in the vicinity of WBN would be insignificant.
Terrestrial Ecology	Impacts on existing plant and animal communities within or adjacent to the disturbed area footprint would be insignificant. Some minor disturbance of communities may occur during construction. No new infestations of exotic invasive plant species are expected.
Threatened and Endangered Species	All construction work would be conducted using BMPs, no additional discharge-related impacts would occur, and intake flows would not be increased over the original design basis for two-unit operation. There would be no effect on state-listed or federally listed aquatic animals or their habitats. No impacts to threatened or endangered terrestrial plant or animal species are expected. No occurrences of state-listed or federally listed plant species are known on, or adjacent to WBN. No impacts to bald eagles or gray bats are expected.
Wetlands	No impacts to wetlands are expected. No disturbance is planned that would affect the one forested wetland adjacent to the project footprint.
Natural Areas	No impacts would occur to the five natural areas within 5 miles of WBN, including the Chickamauga State Mussel Sanctuary.
Cultural Resources (Archaeological and Historical)	Because new ground disturbance would be minimal and only minimal new construction is planned, historic resources on and adjacent to the site and archaeological resources within the area of potential effect would not be adversely affected.

Table 2-1 (continued)

Resource	Potential Environmental Effects
Socioeconomics, Environmental Justice and Land Use	Some impacts to population, including low income and minority groups due to influx of workers; most impacts would be widespread and minor. A noticeable increase in demand for housing and mobile housing locations would occur during peak construction. Some impacts are expected to schools. Minor impacts are expected on land use. Beneficial effects on employment and income, and local governments' revenues during construction.
Floodplains and Flood Risk	No anticipated adverse flood-related impacts.
Seismic Effects	No adverse seismic effects anticipated.
Climatology and Meteorology	A slight change in local meteorology could affect wind dispersion values. Effects expected to be insignificant.
Nuclear Plant Safety and Security	The risks of a beyond-design-basis accident from operation of WBN are small. Increased risk from Unit 2 operation would be extremely low. Risk of and potential impacts from a terrorist attack on WBN are not expected to increase significantly due to completion of WBN Unit 2. Because WBN is an existing, operating nuclear facility, the risks and potential consequences of a terrorist attack already exist, and safeguards have already been taken to protect against such risks.
Radiological Effects	Anticipated effects unchanged since 1995; insignificant.
Radiological Waste	Anticipated effects unchanged since 1995; insignificant.
Spent Fuel Transportation and Storage	Insignificant effects anticipated from the transport or storage of spent fuel.

2.5. Identification of Mitigation Measures

Mitigation of potential environmental impacts includes avoiding, minimizing, rectifying, reducing, or compensating for the impacts. Mitigation measures have been identified in the 1972 FES and subsequent NEPA documents. Those measures are still in effect. This supplemental document identifies mitigation measures to address impacts beyond what were discussed in those earlier reviews. TVA will identify specific mitigations and commitments selected for implementation in the ROD for this project.

TVA has identified the following measures that could be implemented during construction or operation of WBN Unit 2 to address those potential impacts.

TVA will designate certain counties as impacted by the construction process so that they would become eligible for a supplemental allocation from TVA's tax equivalent payments under Tennessee law. . These funds could be used by counties to address impacts on county services.

As part of the DSEP, TVA is conducting a labor study of the potential construction workforce. TVA will provide information from this study to officials in the impacted

counties. This information could help with local planning to accommodate the anticipated temporary population growth.

2.6. The Preferred Alternative

Completion of Unit 2 is TVA's preferred alternative. This alternative addresses the identified need in a cost-effective manner with only limited additional environmental impacts. It permits TVA to make use of an existing asset, the partially completed Unit 2 and potentially helps reduce the cost of TVA power. It also provides TVA flexibility to reduce emissions from its fossil plants by reducing generation from those plants, depending on future events and the demand for energy.

CHAPTER 3

3.0 CHANGES IN THE AFFECTED ENVIRONMENT AND ENVIRONMENTAL CONSEQUENCES

The environmental consequences of constructing and operating WBN were addressed comprehensively in the 1972 FES for WBN Units 1 and 2. Subsequent environmental reviews updated that analysis, as described in Section 1.3 of this FSEIS. By 1996, when the construction of WBN Unit 1 was complete, most of the construction effects had already occurred. As described in Section 2.1, WBN Unit 2 would use structures that already exist and most of the work required to complete Unit 2 would occur inside those buildings. As shown in Figure 1-2, any disturbance proposed for the construction of new support facilities would be within the current plant footprint. Although the facility locations in this tentative site plan are not firm, any relocation would occur within the marked area to be disturbed. TVA would use standard construction BMPs to control minor construction impacts to air and water from dust, sedimentation, and noise.

The reviews by TVA and NRC in 1993 and 1995 focused primarily on the completion of WBN Unit 1. Some modifications to plant design and operations have occurred since that time. Chapter 3 summarizes the environmental effects assessed in past WBN-related environmental reviews, identifies any new or additional effects that could result from the completion and operation of WBN Unit 2, and assesses the potential for impacts. The current review focused on the entire proposed area to be disturbed.

Cumulative Effects

Cumulative effects of constructing and operating WBN Units 1 and 2 were considered in the 1972 FES and the 1995 NRC FES, which TVA adopted. The potential for cumulative effects to surface water and aquatic resources are addressed by the plant's NPDES permit and its monitoring requirements. Concerns over potential cumulative effects to air were tied to emissions from WBF plant, which had not operated since 1983 and has since been retired.

Cumulative effects are also considered in many of the documents incorporated by reference and/or tiered from for this supplement. Most notably, cumulative effects of spent fuel storage and transportation were addressed in the CLWR FEIS; cumulative effects of transportation of radioactive materials were addressed in NUREG-75/038 (NRC 1975); and cumulative effects of hydrothermal and water supply were addressed in the ROS FEIS. In this review, TVA has found that no new or additional cumulative effects beyond those identified in earlier NEPA documents are expected to result from completing the construction of WBN Unit 2. As summarized in Table 2-1, for the most part, only minor, temporary, or insignificant effects are expected for most of the resources considered. As such, these effects are not expected to contribute to cumulative impacts on affected resources. The potential for additional operational cumulative effects are considered in the following assessments.

3.1. Water Quality

3.1.1. Surface Water – Hydrothermal Effects

Hydrothermal effects primarily consist of the impact of the heated effluent from WBN on the Tennessee River. Here, hydrothermal effects are divided into two categories, near-field effects and far-field effects. Near-field effects consist of the impact of the heated effluent on the river water temperature in the immediate vicinity of the plant, as defined by the assigned mixing zones for the outfalls in the NPDES permit. Limits for river water temperature are specified by the State of Tennessee in the NPDES permit for the plant. Far-field effects consist of the impact on the receiving stream on a larger scale, in this case all of Chickamauga Reservoir.

Waste heat created by the operation of WBN is dissipated both in the atmosphere and in the Tennessee River. A description of the heat dissipation system is given in Section 2.2.2. The current configuration of the system includes three outfalls to the river. Outfall 101 includes regulated releases through two multiport diffusers located on the bottom of the river at TRM 527.9. Outfall 102 includes emergency overflow from the plant yard holding pond and consists of a surface discharge from a local stream channel at TRM 527.2. Historically, releases from Outfall 102 have been made only when maintenance is required for Outfall 101. Outfall 113 includes releases from the WBN SCCW system through a discharge structure at TRM 529.2. Outfall 113, originally the outfall for the retired WBF, consists of a shoreline release slightly below the water surface of the river. The current configuration of the SCCW system provides water solely for WBN Unit 1. For the combined operation of Unit 1 and Unit 2, the control structures that regulate the amount SCCW flow between and out of the cooling tower basins would need to be modified to preserve the original design bases for all three outfalls.

An extensive number of previous studies on the hydrothermal characteristics of releases from WBN have been conducted over the years. These studies are described and their results summarized in Appendix A. In general, these studies have basically evaluated and documented:

1. That WBN can be effectively operated without causing violations of water temperature limits in the Tennessee River (near-field effect).
2. The validity of operating assumptions made in previous analyses.
3. The validity of the assigned mixing zones and modeling results for river temperature.
4. Evaluations for changes such as the addition of the SCCW system or the Reservoir Operations Study (ROS).
5. That operation of WBN is not expected to have any noticeable impact on Chickamauga Reservoir (far-field effect).

NPDES River Temperature Limits

The current NPDES permit limits for managing the near-field impact of the thermal effluent from WBN outfalls are summarized in Table 3-1. Those for Outfall 101 and Outfall 102 apply to the temperature of the effluent before it enters the river (i.e., “end-of-pipe” limitations). Those for Outfall 113 are instream limitations and apply relative to the assigned mixing zones. Releases from Outfall 101 can be made only when the flow in the river from WBH is at or above 3500 cfs.

Releases from Outfall 113 do not require a minimum flow in the river, except in events where there is a planned, sudden change in the thermal loading from the SCCW system.

Table 3-1. NPDES Temperature Limits for WBN Outfalls to the Tennessee River

Outfall	Effluent Parameter	Daily Report	Limit
101	Effluent Temperature	Daily Avg	35.0°C (95°F)
102	Effluent Temperature	Grab	35.0°C (95°F)
113	Instream Temperature ¹	Max Hourly Avg	30.5°C (86.9°F)
	Instream Temperature Rise ²	Max Hourly Avg	3.0 C° (5.4°F)
	Instream Temperature Rate-of-Change ¹	Max Hourly Avg	±2 C°/hr (±3.6 F°/hour)
	Instream Temperature Receiving Stream Bottom ³	Max Hourly Avg	33.5°C (92.3°F)

Notes: ¹ Downstream edge of mixing zone
² Upstream ambient to downstream edge of mixing zone
³ Mussel relocation zone at SCCW outlet

Mixing Zones

The mixing zone for Outfall 101 is shown in Figure 3-1. The recommended dimensions of the mixing zone are based on a physical hydrothermal model test of the diffusers (TVA 1977b, 1977c). Measurements from the model indicated that sufficient mixing would be achieved at a distance equivalent to roughly the length of the outflow section of the diffuser ports. The blowdown system includes two diffuser legs, one containing an outflow section 80 feet long (upstream) and one containing an outflow section 160 feet long (downstream). Hence, the assigned mixing zone for Outfall 101 is 240 feet wide and 240 feet downstream. The width of the river at Outfall 101 is about 1100 feet, thus about 80 percent of the river is available for safe passage of fish. The design of the diffusers and mixing zone are based on the operation of both units at WBN, and the extreme river conditions used for the design of the diffuser are still applicable (i.e., minimum river flow of 3500 cfs). For the operation of one unit, the performance of the diffuser was confirmed by field studies after the startup of Unit 1 (TVA 1998b). Similar studies would be performed to confirm the performance of the diffusers with the operation of two units at WBN.

Since releases resulting from the emergency overflow of the yard holding pond are so infrequent, a mixing zone currently is not defined in the NPDES permit for Outfall 102.

For Outfall 113, standards for water temperature are enforced by means of two mixing zones, active and passive, as shown in Figure 3-2. Two mixing zones are used to better align monitoring of Outfall 113 with the behavior of the effluent in the river. Computations and measurements show that spreading of the effluent from Outfall 113 varies substantially between conditions *with* and *without* flow in the river from Watts Bar Dam (TVA 1997b, 2001, 2004b). For conditions *with* flow, the effluent tends to reside in the right-hand-side of the river (facing downstream) and is monitored by the active mixing zone, which includes instream temperature monitors at its downstream edge. For conditions *without* flow, the effluent can spread across the river and is monitored by the passive mixing zone. Since the passive mixing zone encompasses regions of the river that must remain clear for navigation, the adequacy of the passive mixing zone is checked biannually (winter and summer) by special water temperature surveys (i.e., rather than instream monitors). Outfall 113 is a near-surface discharge, and computations and measurements confirm that the heated effluent from Outfall 113 disperses in the surface region of the water column (TVA, 1997b, 2001, 2004b, 2005c, 2006a, 2007b, 2007c), providing ample room beneath for the safe passage of fish, particularly in the deep

navigation channel on the right-hand-side of the river. TVA would not change the dimensions of the Outfall 113 mixing zones with the completion and startup of Unit 2.

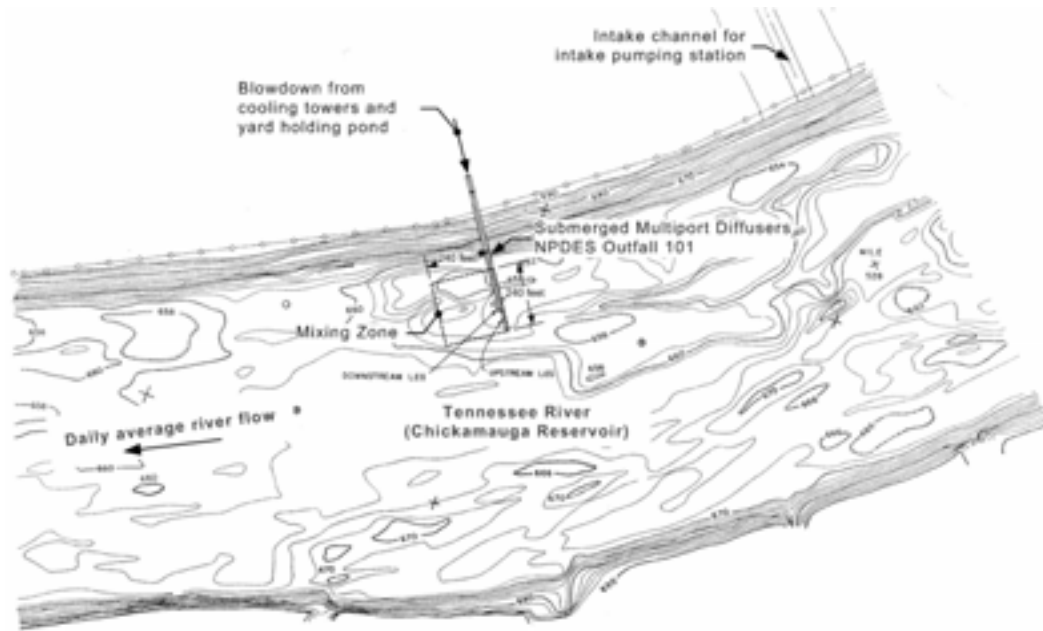

Figure 3-1. Mixing Zone for Outfall 101



Figure 3-2. Mixing Zones for Outfall 113

It is important to note that since the startup of WBN Unit 1, the plant has operated successfully through a wide range of river flow conditions, without any exceedences of the NPDES limits for the near-field impact of thermal effluent on the Tennessee River. Concurrently, no significant

adverse impacts have been reported on the ecological health of the river as a result of releases from any of the WBN discharge structures—Outfall 101, Outfall 102, or Outfall 113.

Updated Hydrothermal Analyses

In depth near-field hydrothermal analyses of the heat dissipation system have been updated for the proposed completion and operation of WBN Unit 2 (Dynamic Solutions 2007). This was necessary for several reasons. First, although the SCCW system has proven to be an effective method to boost generation of the plant, the combined operation of Unit 1 and Unit 2 with the SCCW system had not been examined. Second, detailed multiyear simulations with the dual mixing zone for Outfall 113, as depicted in Figure 3-2, had not been performed. Third, previous model evaluations had not considered the combined operation of Unit 1 and Unit 2 coupled with the river operating policy of the ROS FEIS or the characteristics of new steam generators recently installed for WBN Unit 1. Appendix A includes more detail about previous model evaluations and the modifications to the Outfall 113 mixing zone.

The updated analyses began with the model used for the 1998 EA of the SCCW system (TVA 1998a). For the updated analyses, modifications were made in the model for: (1) combined operation of Unit 1 and Unit 2, (2) discharges from Outfall 113 with dual mixing zones, (3) ambient river conditions based on the river operations policies of the ROS, and (4) performance characteristics of the new steam generators for WBN Unit 1. In this process, the following modeling assumptions are emphasized:

The cooling tower for WBN Unit 2 would be upgraded to provide the same level of performance as that of the cooling tower for Unit 1.

WBN Unit 2 would operate with the original steam generators.

The SCCW system currently serves Unit 1. With the combined operation of Unit 1 and Unit 2, the SCCW system would serve both units. While some modifications to the SCCW system would be required for combined operation (see above), these modifications would be limited to installed plant systems and would not change the volume of water delivered and removed by the SCCW system. The following analysis assumes that the SCCW system would be changed to provide service solely to Unit 2. This assumption provides a suitable bounding estimate of the potential order of magnitude of the hydrothermal impact on the Tennessee River from the operation of Unit 2 while both Units are in operation. Although other options are possible, none would result in a substantial change in volume and/or temperature of flow released to the river through Outfalls 101, 102, and 113.

Mixing of thermal effluent from Outfall 101 is adequately described by the observed behaviour in the physical model study of the discharge diffusers (TVA 1977b; TVA 1997c), and in a field study conducted after the startup of Unit 1 (TVA 1998c).

Mixing of thermal effluent from Outfall 113 is adequately described by an analysis tool recommended by the U.S. EPA known as CORMIX (Jirka, et al. 1996).

Model simulations were performed for a 30-year period based on observed hydrology and meteorology in the upper Tennessee River watershed for years 1976 through 2005. The model input requires the flow and ambient temperature of the river at WBN. To incorporate the impact of the ROS operating policy, a reservoir scheduling model was used to help estimate the hourly river flow at WBN. Hourly values of the ambient water temperature were estimated using SysTemp, a collection of linked water quality models of the key water

bodies in the Tennessee River reservoir system. The reservoir scheduling model and SysTemp were both previously calibrated as a part of the ROS FEIS (TVA 2004a).

An important aspect common to all the above assumptions is that with the addition of Unit 2, the blowdown and SCCW systems would be adapted, if needed, to ensure no substantial change in the design bases for Outfalls 101, 102, and 113. That is, the maximum volume of flow and heat from the outfalls would not change substantially from their original design. For Outfalls 101 and 102, this includes the operation of both WBN units, and for Outfall 113, this includes a maximum flow of about 365 cfs, whether from Unit 1, Unit 2, or both Unit 1 and Unit 2. In this manner, the updated hydrothermal analyses would primarily ascertain the expected impact of recent changes in river operations, and provide assurance that with both WBN units, the current mixing zones and methods of operating the plant and river would effectively satisfy state standards for instream water temperature and provide safe passage for aquatic species in Chickamauga Reservoir.

Two operating cases for WBN were considered as part of the updated hydrothermal analyses—Unit 1 only (i.e., current, base case conditions) and combined operation of Unit 1 and Unit 2, with the SCCW system serving only Unit 2. For both cases, the key statistical properties of flow and temperature of water released from Watts Bar Dam are summarized in Table 3-2. As shown, daily average releases ranged from a minimum of 3300 cfs in May to a maximum of over 150,000 cfs in both March and April. Flows over about 45,000 cfs would be due to spill operations in support of flood control. On an hourly basis, releases can be 0 cfs, due to peaking operations of the hydro units. The overall average release for the entire 30-year period was about 27,000 cfs. The hourly release temperature varied between a minimum of 36.3°F in February and a maximum of 84.6°F in August. Thus, based on historical hydrology and meteorology, the ambient river temperature is not expected to exceed the state standard of 86.9°F.

Table 3-2. Estimated Hydrothermal Conditions for Release From Watts Bar Dam

Month	Daily Average Release (cfs)			Hourly Release (cfs)			Hourly Release Temperature (°F)		
	Min	Mean	Max	Min	Mean	Max	Min	Mean	Max
Jan	5,600	36,900	122,400	0	36,900	122,400	36.6	44.0	52.0
Feb	6,300	43,000	115,300	0	43,000	115,300	36.3	43.8	52.2
Mar	5,000	36,600	156,600	0	36,600	156,600	38.9	48.9	60.0
Apr	3,600	21,000	156,600	0	21,000	156,600	47.8	56.3	65.4
May	3,300	17,300	119,300	0	17,300	119,300	54.4	63.9	73.2
Jun	5,200	21,600	81,300	0	21,600	81,300	61.6	71.3	79.1
Jul	5,900	19,300	60,200	0	19,300	60,200	68.7	76.4	83.9
Aug	5,600	22,600	41,200	0	22,600	49,100	72.4	78.0	84.6
Sep	4,300	22,400	81,300	0	22,400	81,300	69.6	76.2	82.7
Oct	4,000	21,000	70,600	0	21,000	70,600	57.5	68.3	79.2
Nov	6,500	29,700	85,000	0	29,700	85,000	47.1	58.5	68.1
Dec	4,400	32,300	102,300	0	32,300	102,300	37.7	49.3	59.5

Notes:

1. Results per SysTemp hydrothermal model simulation
2. Reservoir operating policy per the ROS FEIS
3. Historical hydrology and meteorology for 1976 through 2005

The following summaries are provided for the results of the updated hydrothermal analyses.

Outfall 101

The estimated hydrothermal conditions for the thermal effluent from Outfall 101 are given in Table 3-3 for sole operation of Unit 1 (base case) and Table 3-4 for the combined operation of both Unit 1 and Unit 2. For the sole operation of Unit 1, the hourly discharge through Outfall 101 varied between 0 cfs and about 108 cfs. Discharges of 0 cfs occur for periods when the release from WBH is less than 3500 cfs. With both WBN units in service, the hourly discharge from Outfall 101 can be as large as 175 cfs, as shown in Table 3-4. This is about 3 percent larger than the maximum value cited in previous design studies (TVA 1977b), but is not considered significant with respect to the as-built size of the blowdown system. For both cases, the estimated maximum daily average effluent temperature was 89.8°F, well below the NPDES limit of 95°F. For the purpose of judging the impact on instream river temperatures, the statistical properties of the resulting hourly river temperature and river temperature rise also are given in Tables 3-3 and 3-4. As shown, the maximum values are well below the state standards of 86.9°F for maximum river temperature and 5.4 F° for maximum river temperature rise. For the latter, the estimated maximum temperature rise is 1.3 F° for the sole operation of Unit 1 and 1.6 F° for the combined operation of both Unit 1 and Unit 2. At these levels, the maximum instream temperature rate-of-change would be well below the state standard of ±3.6 F° per hour.

Table 3-3. Estimated Hydrothermal Conditions for Thermal Effluent From Outfall 101 With Unit 1 Operation

Month	Hourly Discharge (cfs)			Daily Average Effluent Temperature (°F)			Hourly Temperature at Downstream Edge of Mixing Zone (°F)			Hourly Temperature Rise at Downstream Edge of Mixing Zone (F°)		
	Min	Mean	Max	Min	Mean	Max	Min	Mean	Max	Min	Mean	Max
Jan	0	44	102	49.0	64.0	79.4	38.2	45.8	53.8	0.0	0.1	1.1
Feb	0	44	102	49.2	65.9	78.4	37.9	45.6	55.7	0.0	0.1	1.1
Mar	0	43	102	53.2	69.6	82.1	40.3	50.5	61.0	0.0	0.1	1.1
Apr	0	43	108	62.5	74.2	84.6	48.9	58.2	66.9	0.0	0.2	1.3
May	0	43	108	70.7	78.9	85.8	57.3	66.1	73.8	0.0	0.2	0.9
Jun	0	43	108	75.3	83.6	89.0	62.7	72.8	79.6	0.0	0.1	0.8
Jul	0	43	108	80.2	85.6	89.1	70.2	77.5	84.6	-0.2	0.1	0.5
Aug	0	43	108	77.4	85.6	89.8	73.8	78.8	84.7	-0.1	0.0	0.5
Sep	0	43	108	71.6	81.8	88.2	69.9	76.8	83.0	-0.3	0.0	0.5
Oct	0	43	102	63.7	75.3	83.9	58.3	68.8	79.3	-0.3	0.0	0.6
Nov	0	43	102	56.2	69.5	83.3	47.9	59.3	69.7	-0.1	0.0	1.0
Dec	0	43	102	49.4	65.2	81.2	38.2	50.7	61.7	-0.1	0.1	1.2

Notes:

1. Results per WBN hydrothermal model simulation
2. WBN Unit 1 with new steam generators of 2006
3. WBN Unit 2 idle
4. SCCW serving Unit 1
5. Reservoir operating policy per the ROS FEIS
6. Historical hydrology and meteorology for 1976 through 2005

Table 3-4. Estimated Hydrothermal Conditions for Thermal Effluent From Outfall 101 With Unit 1 and Unit 2 Operation

Month	Hourly Discharge (cfs)			Daily Average Effluent Temperature (°F)			Hourly Temperature at Downstream Edge of Mixing Zone (°F)			Hourly Temperature Rise at Downstream Edge of Mixing Zone (F°)		
	Min	Mean	Max	Min	Mean	Max	Min	Mean	Max	Min	Mean	Max
Jan	0	80	165	48.9	64.0	79.3	38.3	45.9	53.9	0.0	0.2	1.4
Feb	0	80	165	49.1	65.9	78.3	38.0	45.7	56.0	0.0	0.2	1.6
Mar	0	79	166	53.1	69.6	82.1	40.3	50.6	61.2	0.0	0.2	1.5
Apr	0	79	171	62.5	74.2	84.5	48.9	58.3	67.3	0.0	0.3	1.6
May	0	80	170	70.6	78.9	85.8	57.4	66.2	73.9	0.0	0.3	1.0
Jun	0	80	171	75.3	83.6	88.9	62.7	72.8	79.6	0.0	0.2	0.9
Jul	0	81	175	80.1	85.5	89.0	70.2	77.6	84.6	-0.2	0.2	0.6
Aug	0	81	172	77.3	85.5	89.8	73.9	78.8	84.7	-0.2	0.1	0.6
Sep	0	80	170	71.6	81.7	88.2	69.9	76.8	83.1	-0.4	0.1	0.6
Oct	0	80	166	63.6	75.2	83.8	58.4	68.9	79.3	-0.4	0.1	0.9
Nov	0	80	166	56.1	69.4	83.2	47.9	59.4	69.8	-0.2	0.1	1.1
Dec	0	79	166	49.3	65.1	81.1	38.4	50.8	61.8	-0.2	0.2	1.5

Notes:

1. Results per WBN hydrothermal model simulation
2. WBN Unit 1 with new steam generators of 2006
3. WBN Unit 2 with original steam generators
4. SCCW serving Unit 2
5. Unit 2 cooling tower performance the same as Unit 1 cooling tower performance
6. Reservoir operating policy per the ROS FEIS
7. Historical hydrology and meteorology for 1976 through 2005

Outfall 102

For both the sole operation of Unit 1 (base case) and the combined operation of both Unit 1 and Unit 2, there were no events with overflow from the plant yard holding pond. As a result, under normal operating conditions, releases from Outfall 102 are not expected.

Outfall 113

The estimated hydrothermal conditions for the thermal effluent from Outfall 113 are given in Table 3-5 for sole operation of Unit 1 (base case) and Table 3-6 for the combined operation of both Unit 1 and Unit 2. For both cases, the hourly discharge through Outfall 113 varied between about 222 cfs and about 294 cfs. This demonstrates that the flow from the SCCW system is independent of the unit served by the system (i.e., Unit 1 for the base case and Unit 2 for the case with both units in operation). In a similar fashion, for both cases, the hourly effluent temperature through Outfall 113 varied between about 39.5°F and 97.3°F. Since the flow and temperature of the SCCW effluent are essentially the same for both cases, similar conditions are found for instream temperature conditions. The estimated maximum hourly instream river temperature for both cases is 84.7°F, well below the NPDES limit of 86.9°F. The estimated maximum hourly instream river temperature rise for both cases is 5.4 F°, which is the same as the current NPDES limit. The estimated largest hourly instream river temperature rate-of-change (up/+ or down/-) for both cases is -3.6 F° per hour, which is the same as the current NPDES limit. The extreme values for the temperature rise and temperature rate-of-change occur in the cooler “winter months” of the year, when the buoyancy-related mixing of the thermal effluent is reduced. In practice, TVA would not risk operation of the SCCW system with the effluent parameters so close to the NPDES limits. In extreme temperature events, the SCCW system would be operated in a more conservative manner than what has been assumed in the hydrothermal model. In particular, the temperature of the Outfall 113 effluent would be reduced

Table 3-5. Estimated Hydrothermal Conditions for Thermal Effluent From Outfall 113 With Unit 1 Operation

Month	Hourly Discharge (cfs)			Hourly Effluent Temperature (°F)			Hourly Temperature at Downstream Edge of Mixing Zone (°F)			Hourly Temperature Rise at Downstream Edge of Mixing Zone (°F)			Hourly Temperature Rate-of-Change at Downstream Edge of Mixing Zone (°F/hr) ¹		
	Min	Mean	Max	Min	Mean	Max	Min	Mean	Max	Min	Mean	Max	Min	Mean	Max
Jan	222	222	223	39.5	62.7	82.7	38.1	45.8	53.7	0.0	1.8	5.4	-3.4	0.0	2.7
Feb	222	222	223	40.7	64.8	82.8	37.8	45.6	55.3	0.3	1.8	5.4	-3.6	0.0	2.4
Mar	222	223	227	45.9	68.3	86.1	40.2	50.9	62.0	0.0	1.9	5.4	-3.6	0.0	2.5
Apr	226	256	277	57.5	72.7	90.2	48.9	58.6	68.5	0.0	2.3	5.4	-3.6	0.0	2.4
May	240	286	292	63.6	79.3	90.9	56.8	66.3	74.6	0.0	2.4	5.4	-3.0	0.0	1.8
Jun	257	291	292	68.6	83.8	94.2	62.7	73.1	79.8	0.0	1.8	5.2	-2.8	0.0	1.7
Jul	275	292	293	71.6	86.1	97.3	70.2	77.8	84.5	0.0	1.4	4.3	-2.2	0.0	1.7
Aug	284	292	293	73.2	85.5	94.9	73.6	78.9	84.7	0.0	0.9	3.5	-2.0	0.0	1.5
	291	292	293	65.7	81.7	92.6	69.6	76.9	83.0	0.0	0.7	2.9	-1.7	0.0	1.3
Oct	287	291	292	57.7	75.0	89.7	58.3	69.3	80.4	0.0	1.0	4.8	-2.8	0.0	2.0
Nov	226	258	288	52.7	69.7	85.7	47.9	59.8	70.9	0.0	1.3	5.4	-3.4	0.0	2.1
Dec	222	222	226	44.5	64.7	84.4	39.1	51.0	63.2	0.0	1.7	5.4	-3.5	0.0	2.1

¹Amount of change in reiver temperature, up or down, in one hour.

Additional Notes:

1. Results per WBN hydrothermal model simulation
2. WBN Unit 1 with new steam generators of 2006
3. WBN Unit 2 idle
4. SCCW serving Unit 1
5. Reservoir operating policy per the ROS FEIS
6. Historical hydrology and meteorology for 1976 through 2005

Table 3-6. Estimated Hydrothermal Conditions for Thermal Effluent From Outfall 113 With Unit 1 and Unit 2 Operation

Month	Hourly Discharge (cfs)			Hourly Effluent Temperature (°F)			Hourly Temperature at Downstream Edge of Mixing Zone (°F)			Hourly Temperature Rise at Downstream Edge of Mixing Zone (F°)			Hourly Temperature Rate-Of-Change at Downstream Edge of Mixing Zone (F°/hr)		
	Min	Mean	Max	Min	Mean	Max	Min	Mean	Max	Min	Mean	Max	Min	Mean	Max
Jan	222	222	222	39.5	62.6	82.6	38.1	45.8	53.7	0.0	1.8	5.4	-3.6	0.0	2.7
Feb	222	222	222	40.7	64.7	82.7	37.8	45.6	55.3	0.3	1.8	5.4	-3.5	0.0	2.4
Mar	222	222	227	45.9	68.2	86.0	40.2	50.9	62.0	0.0	1.9	5.4	-3.5	0.0	2.5
Apr	226	256	277	57.3	72.6	90.2	48.9	58.6	68.4	0.0	2.3	5.4	-3.5	0.0	2.6
May	240	285	292	63.5	79.2	90.8	56.7	66.2	74.6	0.0	2.3	5.3	-3.0	0.0	1.8
Jun	257	291	292	68.5	83.7	94.1	62.7	73.0	79.8	0.0	1.7	5.2	-2.8	0.0	1.7
Jul	275	291	294	71.5	86.0	97.2	70.2	77.8	84.5	0.0	1.4	4.3	-2.2	0.0	1.7
Aug	284	292	292	73.1	85.4	94.8	73.6	78.9	84.7	0.0	0.9	3.4	-2.0	0.0	1.5
Sep	291	292	292	65.5	81.6	92.5	69.6	76.8	83.0	0.0	0.7	2.9	-1.7	0.0	1.3
Oct	287	291	292	57.5	74.8	89.6	58.3	69.3	80.4	0.0	0.9	4.8	-2.7	0.0	2.0
Nov	226	258	288	52.6	69.6	85.7	47.9	59.8	70.9	0.0	1.3	5.4	-3.4	0.0	2.1
Dec	222	222	226	44.3	64.6	84.3	39.1	51.0	63.3	0.0	1.7	5.4	-3.5	0.0	2.1

Notes:

1. Results per WBN hydrothermal model simulation
2. WBN Unit 1 with new steam generators of 2006
3. WBN Unit 2 with original steam generators
4. SCCW serving Unit 2
5. Unit 2 cooling tower performance the same as Unit 1 cooling tower performance
6. Reservoir operating policy per the ROS FEIS
7. Historical hydrology and meteorology for 1976 through 2005

by passing additional water through the SCCW bypass conduit or perhaps by removing the SCCW system from operation.

For Outfall 113 the NPDES permit also includes a limitation on the maximum temperature of the receiving stream bottom (mussel relocation zone). This temperature is not estimated by the WBN hydrothermal model. However, historical data can be examined to demonstrate that the Outfall 113 effluent would not create a significant impact on river bottom temperature. Measured temperatures for the Outfall 113 effluent and river bottom in the mussel relocation zone (MRZ) are shown in Figure 3-3. Data are shown for 1999, when the SCCW system first began operation, through mid-2004. In this span, 2002 was among the warmest years since TVA began monitoring water temperature below Watts Bar Dam. As shown, even in a warm year, the maximum MRZ bottom temperature is only about 84°F, well below the NPDES limit of 92.3°F. It is important to note that the maximum allowable temperature of essential raw cooling water (ERCW) for continued operation of WBN Unit 1 currently is 85°F, which is needed to guarantee a safe shutdown of the reactor in the event of an emergency. Efforts currently are underway to increase this limit to 88°F (TVA, 2004c, 2006b). The completion of Unit 2 is expected to include an ERCW limit of 88°F. If the water temperature at the plant pumping station located 1.3 miles downstream of Outfall 113 approaches 88°F, the operation of WBN would be suspended, and thus the heat load from the SCCW system would be dramatically reduced. Therefore, in terms of protecting bottom-dwelling species and fish passage, the impact to the river from Outfall 113 would by necessity be reduced by WBN suspension of operations should the ambient bottom temperature ever reach 88°F, still well below the MRZ temperature limit of 92.3°F.

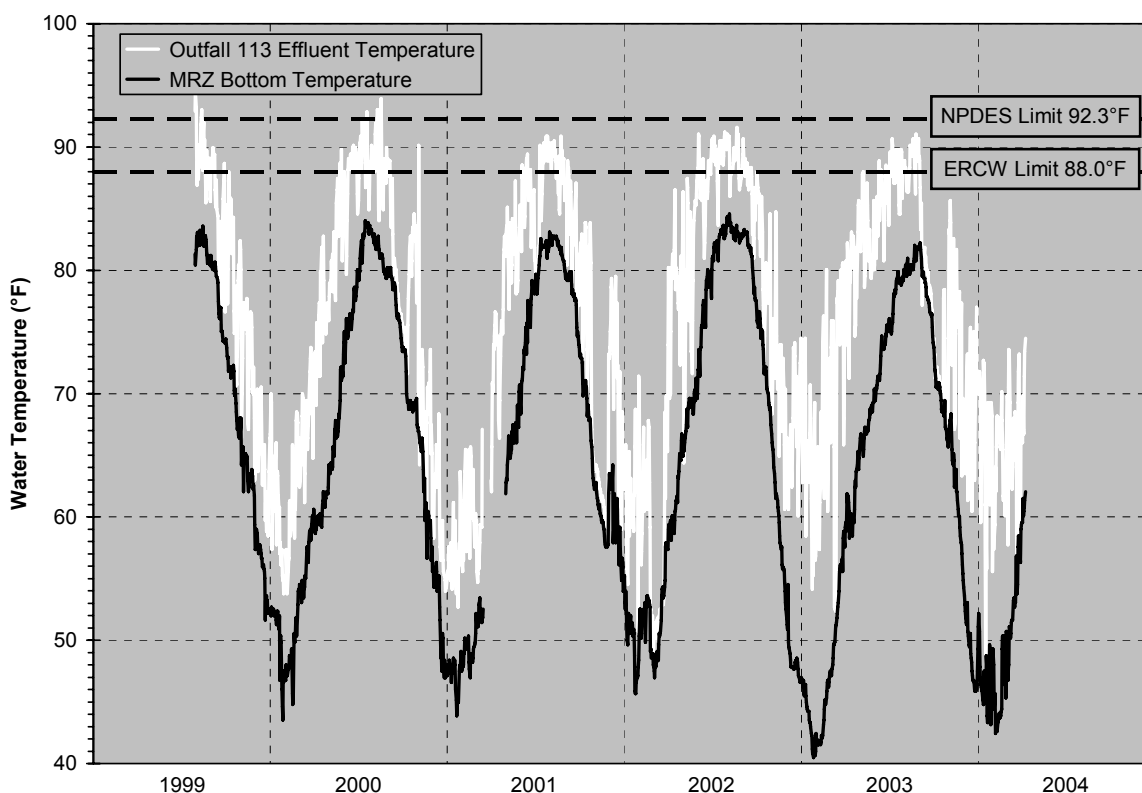

Figure 3-3. Measured Temperatures for Outfall 113 Effluent and Bottom of Mussel Relocation Zone

Impact on WBN Operation

As emphasized in Section 2.2.1, the purpose of the WBN SCCW is to enhance the performance of the unit(s) that it serves. When TVA anticipates that one or more of the NPDES temperature limits are threatened for Outfall 113, part of the SCCW inflow is diverted via the bypass to the discharge conduit to reduce the temperature of the SCCW effluent (e.g., see Figure 2-2). If the temperature of the Outfall 113 effluent cannot be sufficiently reduced by this process, the SCCW system is removed from service. In this manner, the impact of the SCCW system on WBN operation can be evaluated based on the length of time the SCCW system is placed in bypass and the length of time the SCCW system is removed from service. Provided in Table 3-7 is a summary of these impacts for the two cases examined herein. As noted, compared to current conditions with the SCCW system supporting Unit 1, combined operation of both units with the SCCW system supporting Unit 2 provides a slight reduction in the hours of required bypass operation, and no change in the number of hours the system must be removed from service. For all practical purposes, given modeling uncertainties, the results in Table 3-7 suggest that the completion and operation of Unit 2 as assumed herein would not create a substantive change in the operation of the SCCW system. The average annual generation for base-case conditions with Unit 1 obtained by the updated analyses was about 10,602,000 megawatt hours per year (MWh/year). For the combined operation of Unit 1 and Unit 2, the average annual generation obtained by the analyses was about 21,182,000 MWh/year, which is less than 0.01 percent less than twice the amount of generation for the base-case (Unit 1) conditions. This slight difference is due to the minor change in performance characteristics of the new steam generators for Unit 1 verses the original steam generators for Unit 2.

Table 3-7. Predicted SCCW Impact on WBN Operation

Case	Average Hours per Year SCCW in Bypass	Average Hours per Year SCCW Removed From Service
Unit 1 only with SCCW serving Unit 1 (base case)	525	10
Unit 1 and Unit 2 with SCCW serving Unit 2	515	10

Low River Flow

It is important to note that the simulation period from 1976 through 2005 contains four of the five driest years ever recorded in East Tennessee, 1988, 1986, 2000, and 2005 (1st, 3rd, 4th, and 5th driest for period of record from 1875 to present). Thus, the simulations summarized herein encompass perhaps near the most extreme conditions expected for the impact of WBN thermal effluent on the river. For Outfall 101, the extent of dry conditions is of little significance because the thermal effluent can be released from Outfall 101 only when the discharge from Watts Bar Dam is at least 3500 cfs. That is, even in the driest years, there will be at least 3500 cfs of flow in the river for the assimilation of waste heat from WBN. The minimum daily average release in Table 3-2, 3300 cfs, would allow a release of 3500 cfs for at least 22 hours in a single day. In practice, hydro releases from Watts Bar Dam are usually made at levels above 3500 cfs (e.g., 6000 cfs). Under these conditions, the impact of a dry year is to reduce the number of hours per day that a flow of 3500 cfs can be provided for Outfall 101, thereby forcing a greater volume of water to be stored in the WBN yard holding pond. This would increase the probability of an overflow from the yard holding pond and unwanted releases from Outfall 102. But as presented earlier, in the 30-year

simulations, there were no events where it was found necessary to provide releases from the yard holding pond via the emergency overflow (i.e., including years such as 1988).

For Outfall 113, the impact of a low flow year would be to increase the duration of events where hourly releases from the SCCW system are made in the absence of hourly releases from Watts Bar Dam. In general, for such events, if there is a threat to one or more of the hourly instream water temperature limits, the amount of heat released from Outfall 113 would be reduced by passing water through the SCCW bypass conduit or perhaps by removing the SCCW system from operation. Since the plant can be operated without the SCCW system in service, such action poses no threat to the overall integrity of WBN generation. Overall, because WBN in closed mode uses such a small amount of flow compared to the potential minimum daily average flow in the river, the plant thermal effluent under extreme low flow conditions would not have an adverse impact on water temperature in the Tennessee River.

Overall Near-Field Effects

Overall, with the recent changes that have been made at the plant (e.g., SCCW system and new steam generators for Unit 1) and for the operation of the Tennessee River (i.e., ROS), the updated hydrothermal analyses reconfirm, as concluded in the 1972 FES, that the operation of two units at WBN will not have a significant impact on near-field hydrothermal conditions in the Tennessee River. Effects on water temperatures in the river can be effectively maintained within the current NPDES limits for all the plant discharge outfalls without significant adverse effects on plant generation. Additionally, data from recent field studies (Appendix A) support the methods of modeling the dissipation of waste heat in the river, and the patterns of mixing from the outfalls provide ample space for fish passage and protection of bottom habitat.

Far-Field Effects

By virtue of the fact that the heated effluent is expected to have an insignificant impact on near-field conditions in river, far-field impacts on Chickamauga Reservoir also are expected to be insignificant, for both the operation of one or two units at WBN. This is supported by the WBN discharge temperature limit evaluation conducted in 1993 (TVA 1993b), by water quality modeling performed as part of the ROS FEIS (TVA 2004a), and by operating experience since the startup of Unit 1 in 1996. Ongoing activities under the TVA Reservoir Releases Improvement Program and the TVA Vital Signs Monitoring Program would continue to provide close scrutiny of any potential far-field impacts from the heated effluent from WBN.

The near-field and far-field effects summarized above are based on the hydrothermal analyses described herein, and are judged to have no significant impact on temperatures in Chickamauga Reservoir. That conclusion, however, is limited to the impacts of discharge to the Tennessee River from Outfalls 101, 102, and 113 associated with the presumed simultaneous operation of Watts Bar Units 1 and 2. The potential for cumulative effects of the completion of WBN Unit 2 in conjunction with other factors that could impact Tennessee River temperatures was also considered.

In June 2004, following completion of a detailed ROS, TVA implemented a new reservoir operating policy (TVA 2004a). This policy specified changes in the operating guide curves at Chickamauga and other reservoirs. Potential changes in reservoir and water quality characteristics were studied in detail as a part of the ROS FEIS. These characteristics included turbine discharges and associated temperatures, residence times, thermal

stratification, both cold and warm water volumes, dissolved oxygen, and algae. The impacts of the adoption of the ROS preferred operating policy for all of these characteristics, relative to the previous operating policy, were determined to be insignificant in Chickamauga Reservoir. There is no evidence to suggest that the adoption of the new operating policy has had or will have any contribution to cumulative effects in Chickamauga Reservoir. Whereas the ROS studies included only the operation of WBN Unit 1, the updated hydrothermal analyses summarized above show that the impact to the near-field river temperature of adding WBN Unit 2 would be insignificant. As such, the startup of WBN Unit 2 would not change this conclusion regarding the potential for cumulative effects.

3.1.2. Surface Water – Chemical Additives to Raw Water

The referenced earlier environmental reviews analyzed potential impacts to surface water and water quality. A primary area of concern for surface water and water quality relates to the chemicals added to treat raw water. These earlier analyses continue to adequately depict the kinds of chemicals used at the plant and associated environmental impacts.

Proposed chemical additives and their respective toxicological data are presented to the state for approval prior to plant use in the facility's Biocide and Corrosion Treatment Plan (B/CTP) required by the WBN Unit NPDES permit. To ensure the water quality criteria in the receiving stream is maintained, the state reviews the chemical usage request and evaluates the reasonable potential environmental impacts of a specific chemical discharge to determine the plant NPDES permit monitoring requirements and discharge limits. Upon start of operation in May 1996, WBN was issued NPDES permit number TN0020168 (TVA 2005d). WBN is authorized to discharge process and non-process wastewater, cooling water and storm water runoff from Outfall 101 and Outfall 102 turbine building sump water, alum sludge supernate, reverse osmosis reject water, drum dewatering water, water purification plant water, and storm water runoff from internal monitoring point (IMP) 103; metal cleaning wastewater, turbine building station sump water, diesel generator coolant, and storm water through IMP 107; treated sanitary wastewater through IMP 111; HVAC cooling water, storm water, and fire protection wastewater through Outfall 112; and SCCW from Outfall 113 to the Tennessee River (refer to Figure 1-2, Unit 2 Site Plan and Appendix B, NPDES Flow Diagram). In addition to revisions to the B/CTP, the potential sources of chemicals and chemical quantities are reviewed and updated in connection with the application for NPDES Permit renewal. Compliance with the State Water Quality criteria is also confirmed by routine semi-annual Whole Effluent Toxicity (WET) testing at Outfall 101, Outfall 112, and Outfall 113.

TVA applied to renew the WBN permit in May 2006. To support the application for this permit reissuance, a detailed walkdown of the plant was conducted to ensure that previously identified discharge point sources remain valid. A comprehensive sampling and analysis event was also conducted to characterize waste water discharges from the authorized discharge points.

As a component of the NPDES Permit, Part III, Section G, B/CTP, WBN is authorized to conduct treatments of intake or process waters with biocides, dispersants, surfactants, corrosion inhibiting chemicals, and detoxification chemicals. To ensure protection of the receiving stream, water treatment processes are controlled to comply with State Water Quality criteria and applicable NPDES permit conditions. WBN monitors effluent discharges and reports to the state the specific chemicals injected along with the respective active ingredient discharged on the monthly Discharge Monitoring Report (DMR) and the Annual B/CTP Report. In addition, WBN performs semi-annual WET testing at Outfall 101, Outfall 112, and Outfall 113. Most of the chemicals used in these treatment programs are added at

the IPS to ensure all raw water systems are protected. Several of these systems, the High Pressure Fire Protection and the ERCW systems in particular, are essential for the safe operation of the plant.

While WBN has requested modifications to the B/CTP over the years, the approach and active ingredients for the various water treatment programs at WBN have not fundamentally changed. Proposed chemicals undergo an extensive toxicological review and comparison with maximum instream wastewater concentrations to ensure water quality standards are met. The products used have changed over the years to slightly different formulations of the same active ingredients or constituents and the processes or frequencies of applying those products occasionally have been changed. These B/CTP modifications continue to provide the same high level of protection for aquatic life in the Tennessee River while increasing the flexibility of plant equipment treatment options. Most recently, WBN submitted a B/CTP modification request to the state in December 2006. TVA sought approval (1) to replace the dispersant PCL-401 with 73200, (2) for continuous use of oxidizing biocides, and (3) to chlorinate using sodium hypochlorite. In addition, TVA requested to add the non-oxidizing biocide H150M to the B/CTP approval list. This request was approved by the state on April 30, 2007. The history of the use of chemicals for treatment during the same time period is shown in Table 3-8 and Table 3-9.

Table 3-8. History of Betz Chemical Treatment of Raw Water at WBN 1996-Present Chemicals

Chemical	Start Year	End Year	System
Clamtrol CT1300*	1996	1998	ERCW/RCW
Spectrus NX1104*	1998	Present	ERCW/RCW
CopperTrol CU-1	1996	1998	ERCW/RCW
Biotrol 88P	1996	1998	ERCW/RCW

*Vendor global chemical name change from Clamtrol CT1300 to Spectrus NX1104 in 1998

**ERCW = Essential Raw Cooling Water; RCW = Raw Cooling Water

Table 3-9. History of Nalco Chemical Treatment of Raw Water at WBN 1996-Present¹

Chemical	Start Year	End Year	System
H-901G	1996	Present	ERCW ³ /RCW ⁴
Coppertrol	1996	1999	ERCW/RCW
PCL-10Z	1996	2002	ERCW/RCW
PCL-60K	1996	2002	ERCW/RCW
PCL-401	1996	2006	ERCW/RCW
Towerbrom 960	1999	Present	Cooling Tower
H-130M ²	2002	2002	ERCW/RCW
MSW-109	2003	Present	ERCW/RCW
H-130M	2004	2004	ERCW/RCW
Coagulant Aid-35	2004	Present	ERCW/RCW
H150M	2005	Present	ERCW/RCW

¹ Known as Calgon Corporation, 1996-2001; Ondeo-Nalco, 2001-2003; Nalco, 2003-present

² H-130M used with no detoxification in 2002

³ ERCW = Essential Raw Cooling Water

⁴ RCW = Raw Cooling Water

Raw Water Chemical Treatment Summary for the WBN Unit 1 B/CTP

The following summarizes chemical treatment programs currently in use or available for future use at WBN Unit 1 and/or Unit 2 for corrosion, deposit, microbiological, and macrofouling control in the raw water systems in accordance with the current B/CTP.

Protection of the raw water cooling water pipe systems requires oxidizing biocide (chlorination) and non-oxidizing biocide treatments to control macro invertebrates and microbiologically induced corrosion (MIC). WBN currently uses products from Nalco, a major industrial water treatment company.

Raw Water Corrosion and Deposit Treatment

Mild Steel Corrosion and Deposit Control. WBN uses a zinc/orthophosphate-based program (MSW-109) for mild steel corrosion control of the ERCW and raw cooling water (RCW) systems. MSW-109 contains 12.6 percent zinc chloride and 36 percent orthophosphate. A seasonal feed program is used where MSW-109 is fed to the raw water system when river water temperature is above 60° F. The concentration of zinc and phosphorous is not to exceed 0.2 parts per million (ppm) at effluent discharges Outfall 101 and Outfall 113.

WBN has the option to feed a dispersant (73200) to the ERCW and RCW systems that controls deposits of calcium phosphate, zinc, iron, manganese, and suspended solids. Dispersant 73200 contains 36 percent high stress polymer (HSP). The active HSP level will not exceed 0.2 ppm at effluent discharges Outfall 101 and Outfall 113.

Copper Corrosion Control. WBN has the option to feed tolytriazole (Nalco 1336) on a continuous basis to small portions of the ERCW and RCW systems for copper corrosion control. Nalco 1336 contains 42.8 percent tolytriazole. Tolytriazole level will not exceed 0.25 ppm at effluent discharges Outfall 101 and Outfall 113.

Raw Water Microbiological/Macrofouling Treatment

Microbiological Control. Microbiological and macrofouling refers to the undesirable accumulation of microorganisms, plants, algae, and aquatic animals on submerged structures and piping systems. WBN currently injects on a continuous basis the oxidizing biocide BCDMH (H-901G) for microbiological and macrofouling control in the ERCW and RCW systems. Continuous oxidation is necessary to ensure plant safety as TVA has recently observed year-round veliger (mussel larvae) infestations. H-901G puts 57 percent of its active halogen ingredient into solution as bromine and chlorine. Chlorine, or Total Residual Oxidant (TRO) is monitored five (5) days per week at Outfall 101 and Outfall 113 in accordance with permit requirements to ensure discharge limits of 0.10 ppm or 0.158 mg/l daily maximum (respectively) are met.

As an alternative to H-901G, WBN has the option to feed liquid bleach in the form of sodium hypochlorite. Liquid bleach, containing 10.2 percent available chlorine, can also be fed on a continuous basis. Monitoring for chlorine levels in the effluent would remain the same as for H-901G.

An option to feed a biodetergent (73551) to increase the efficacy of either H-901G or liquid bleach with microbiological control has been retained by WBN. The 73551 biodetergent consists of a 20 percent blend of non-ionic surfactants and is fed for 30 minutes one to three times per week to the ERCW and RCW systems. The active surfactant level will not exceed 2.0 ppm to the effluent discharges Outfall 101 and Outfall 113.

WBN de-chlorinates as required using sodium bisulfite (Nalco 7408) to ensure the current discharge limit of 0.1 ppm TRO is not exceeded at effluent discharges Outfall 101 or 0.158 mg/l daily maximum at Outfall 113. Nalco 7408 consists of 45 percent sodium bisulfite and is fed at a ratio of approximately 4 ppm product for every 1.0 ppm of TRO. The sodium bisulfite level will not exceed 10 ppm at effluent discharges Outfall 101 and Outfall 113.

Macrofouling Control.

When river temperatures are greater than or equal to 60°F, WBN terminates oxidizing biocides treatment and performs a periodic (minimum of 4 times per train per year) non-oxidizing biocide treatment of the raw water systems. A train is the cluster of equipment which must be operational to perform a certain function.

WBN uses a non-oxidizing biocide (H150M, Clamtrol) to limit Asiatic clam and zebra mussel populations in the raw water system, the presence of which can significantly affect ERCW and RCW system performance. H150M is a quaternary amine (quat) which consists of 25 percent dimethyl benzyl ammonium chloride and 25 percent dimethyl ethylbenzyl ammonium chloride. H150M is used to treat the A and B trains of ERCW and the RCW systems a minimum of four times per year. Spectrus NX1104 (quat), and Clamtrol are used for short-term (4-6 hour), low concentration applications for cross-tie (piping which joins the A train to the B train) treatments.

In order to limit the active H150M residual to no more than 0.05 ppm at effluent discharges Outfall 101 and Outfall 113, bentonite clay (Coagulant Aid-35) is fed into the Unit 1 cooling tower basin prior to effluent discharge to the river via NPDES outfalls Outfall 101 or Outfall 113. Coagulant Aid-35 is fed at a ratio of 5 parts to 1 part H150M during each mollusk treatment. Total clay level is not to exceed 10 ppm at effluent discharges Outfall 101 and Outfall 113. The effectiveness of detoxification is confirmed with twice daily sampling for the active ingredient in the discharge during the treatment period.

Cooling Tower Treatments

WBN currently adds Towerbrom 960 to the cooling tower basin on a periodic basis for microbiological control for CCW. Towerbrom 960 is an oxidizing biocide, containing 57 percent available halogen, and generates bromine and chlorine solutions when dissolved in water. WBN also has the option to feed liquid bleach in place of Towerbrom 960. This treatment is performed with the diffusers and the SCCW system isolated (closed). To ensure the current discharge limit of 0.1 ppm TRO is not exceeded at effluent discharges Outfall 101 or 0.158 mg/l daily maximum at Outfall 113, the chemically treated water is not released to the river until the discharge concentration of chlorine is below the NPDES permit limit. To enhance the effectiveness of this program, WBN has requested the option to feed Biodetergent 73551 with Towerbrom 960. WBN de-chlorinates as needed using sodium bisulfite (Nalco 7408) to ensure the current discharge limit of 0.1 ppm TRO is not exceeded at effluent discharges Outfall 101 or 0.158 mg/l daily maximum at Outfall 113. Nalco 7408 is ratio-fed at a rate of 4 ppm product for every 1.0 ppm of chlorine.

Additional Chemicals Used in WBN Processes

In addition to the raw water additives for biocide and corrosion treatment chemicals discussed above, other chemical additives are used in plant processes. These chemicals may be found in trace quantities at the various NPDES discharge points (Outfall 101, Outfall 102, IMP 103, IMP 107, Outfall 112) due to cooling tower blowdown (CTBD) to the Yard Holding Pond (YHP) or Outfall 101, leakage, and system maintenance activities (see Figure 2.1). Since the potential discharge of these chemicals is through the CTBD line,

Outfall 113 does not receive these discharges. The summary of potential chemicals discharged by NPDES outfall number is shown in Table 3-10.

Table 3-10. Potential Chemical Discharge to NPDES Outfalls at WBN

Outfall Number	Outfall Description	Chemical
101	Diffuser Discharge	Ammonium Hydroxide, Ammonium Chloride, Alpha Cellulose, Boric Acid, Sodium Tetraborate, Bromine, Chlorine, Copolymer Dispersant, Ethylene Glycol, Hydrazine, Laboratory Chemical Wastes, Lithium, Molybdate, Monoethanolamine, Molluscicide H150M, Oil and Grease, Phosphates, Phosphate Cleaning Agents, Paint Compounds, Sodium Hydroxide, Surfactant - Dimethylamide and Alcohol, Tolyltriazole, Zinc Sulfate, Zinc Acetate Dihydrate, LCS-60
102	YHP Overflow Weir	Alternate discharge path for Outfall 101
103	LWTP	Ammonium Hydroxide, Ammonium Chloride, Boric Acid, Sodium Tetraborate, Bromine, Chlorine, Copolymer Dispersant, Ethylene Glycol, Hydrazine, Laboratory Chemical Wastes, Molybdate, Monoethanolamine, Molluscicide H150M, Oil and Grease, Phosphates, Phosphate Cleaning Agents, Paint Compounds, Sodium Hydroxide, Surfactant - Dimethylamide and Alcohol, Tolyltriazole, Zinc Sulfate
107	LP and ULP	Metals - Iron and Copper, Acids and Caustics, Ammonium Hydroxide, Ammonium Chloride, Boric Acid, Sodium Tetraborate, Bromine, Chlorine, Copolymer Dispersant, Hydrazine, Laboratory Chemical Wastes, Molybdate, Monoethanolamine, Molluscicide H150M, Oil and Grease, Phosphates, Phosphate Cleaning Agents, Sodium, Sodium Hydroxide, Surfactant - Dimethylamide and Alcohol, Tolyltriazole, Zinc Sulfate
111	Sewage Treatment Plant	Chlorine, Organic Matter, Laboratory Chemical Wastes, Paint Compounds
112	Runoff Holding Pond	Chlorine, Organic Matter, Paint Compounds, Potable Water (Cooling Tower at Training Center), High Pressure Fire Protection flushes, Superior SWS 4550

Primary System Chemical Additions

The Primary Systems are generally located in the radiologically controlled areas of the plant and support the Reactor Cooling System (RCS). These systems include the Component Cooling Water System (CCS) and the Ice Condenser.

RCS Corrosion and pH Control. At plant startup lithium hydroxide is added to the RCS via components in the Auxiliary Building to establish the initial pH and corrosion control. After

the reactor becomes critical, lithium is a byproduct of a neutron-boron reaction and no further lithium hydroxide additions are required. A boric acid concentration is established in the RCS at startup to control neutron flux and is limited based upon core design. This concentration is reduced for approximately one month after restart from a refueling outage. For approximately the next month the concentration is increased and then over the course of the operating cycle the concentration steadily decreases. Hydrogen peroxide is added during a refueling outage to enhance primary system cleanup to reduce radiation exposure to maintenance personnel and ensure water clarity. Hydrazine is added stoichiometrically prior to heat-up from a refueling outage to scavenge oxygen and minimize system corrosion. The RCS is a closed system, therefore any leakage or letdown from the RCS system would be processed through the liquid radiological waste system.

RCS Corrosion Control and Radioactive Dose Reduction. WBN received state approval in October 2006 to add low concentrations of Zinc Acetate Dihydrate to the RCS. Industry experience has shown zinc additions yield a 20 to 30 percent reduction in plant dose rates and reduce primary water stress corrosion cracking in plant materials. Zinc would also reduce the corrosion rate and release of corrosion products to the coolant from the metal surfaces of replacement or new steam generators. WBN initiated injection at 20 grams per day via components in the Auxiliary Building and maintained this feed rate until a zinc residual was observed in RCS samples. As the residual built in and the crud layer absorption of zinc slowed, WBN lowered the feed rate to maintain 5 ppb zinc in the RCS. Since the RCS is a closed system, any leakage or letdown from the RCS system would be processed through the liquid radiological waste system. A history of Zinc Acetate Dihydrate and other chemical treatment are shown in Table 3-11.

Table 3-11. History of Other Chemical Treatment of Raw Water at WBN 2006-Present

Chemical	Start Year	End Year	System
Zinc Acetate Dihydrate	2006	Present	RCS ¹
Superior SWS 4550	2006	Present	Training Center Cooling Tower

¹ RCS = Reactor Coolant System

Component Cooling Water Corrosion and pH control. Sodium molybdate, tolyltriazole, sodium hydroxide are added to this system in the Auxiliary Building to control pH and corrosion. Leakage from this system would be processed through the radwaste system while complete system draining is routed to the Turbine Building Station Sump (TBSS). The TBSS is normally routed to the discharge to the Low Volume Waste Treatment Pond (LVWTP), but can be routed to the Lined Pond (LP), the Unlined Pond (ULP), or the YHP.

Ice Condenser. Sodium tetraborate is used in the Ice Condenser for emergency boration. The Ice Condenser is located in the Reactor Building and the components to mix and initially freeze the tetraborate solution are located in the Additional Equipment Building. Ice melt bypasses the radwaste demineralizer beds, is routed to a radwaste discharge tank, and is discharged through the radwaste system. Ethylene glycol is used in the ice condenser chiller packages. Leakage with concentrations less than 10 percent is discharged to the ULP for degradation, while greater than or equal to 10 percent is collected in drums and shipped to a vendor to be recycled.

Secondary System Chemical Additions

The main Secondary Systems are the Condensate System, the Main Feedwater System and the Main Steam System. The purpose of the Secondary Systems is to heat and pressurize cooler water to produce feed water for the steam generators. The Main Steam System then routes steam from the steam generators to the plant turbines for power generation. The Condensate System receives exhausted steam from the turbine discharge to repeat the cycle.

Corrosion and Deposit Treatment. Hydrazine, ammonia, ammonia chloride, boric acid, and monoethanolamine (ETA) are injected into the Condensate System at the turbine building for secondary chemistry control. Hydrazine functions as a dissolved oxygen scavenger while ammonia and ETA are added for pH control and corrosion control. Ammonia chloride is injected as necessary for molar ratio control to aid in reduction of stress corrosion cracking in the steam generators. Boric acid is also injected at the turbine building for reduction or prevention of stress corrosion cracking in the steam generators. The reduction of stress corrosion cracking assists in the maintenance of steam generator integrity thereby realizing their design lifespan. Up to 300 pounds of modified alpha cellulose may be added to the condenser intake channel to temporarily plug pinhole tube leaks in the condenser.

Other Plant Systems

Chemicals are also added to other plant systems and include Chilled Water Systems, Turbine Building Heating System, Auxiliary Boilers, and Diesel Jacket Cooling Systems.

- Hydrazine and ammonia are added to the Chilled Water Systems, Turbine Building Heating System, and Auxiliary Boilers for pH and corrosion control:
- LCS-60 is added to the diesel jacket cooling water for corrosion control and consists of sodium nitrite, sodium tetraborate and tolytriazole.

These chemicals are incidental discharges that are controlled via BMPs. Discharges occur via leakage or maintenance activities and are discharged to the LP, ULP, LVWTP, or YHP.

Superior SWS 4550 is added to the Training Center Cooling Tower Water System to neutralize the chemical deposits in the Training Center Cooling Tower and inhibit corrosion. Any blowdown discharge is routed to the Runoff Holding Pond (RHP) and Outfall 112.

Environmental Consequences of Chemical Additions to Raw Water

Under the preferred alternative, TVA would complete the construction of WBN Unit 2 and the plant would operate at its full capacity as originally designed. Prior to construction activity, WBN would develop an erosion and sedimentation control plan as part of an application for a General NPDES Permit for Storm Water Discharges Associated with Construction Activity although it is expected that most of the construction work would occur inside constructed buildings, and all of the work is expected to occur within the existing plant site footprint. Operation of Unit 2 along with Unit 1 would result in an increase of raw water intake usage at the IPS by an estimated 33 percent compared to sole operation of Unit 1, with a corresponding increase of ERCW and RCW raw water chemical additives by an estimated 33 percent. This increase is within original design basis for operation of Units 1 and 2. Since an additional existing cooling tower would be placed in service, Towerbrom 960 treatment for CCW treatment would increase by an estimated 100 percent.

The current NPDES permit contains provisions requiring authorization of the B/CTP and the use of the water treatment chemicals described above are expected to continue in use if and when WBN Unit 2 starts up. TVA would use the same protocols for Unit 2 as used with Unit 1 to show permit compliance with the treatment plans using mass balance calculations where possible. In addition, detoxification of non-oxidizing biocides would be confirmed with twice-daily sampling for the active ingredient in the effluent during the treatment period.

The state retains the authority to require WBN to conduct additional monitoring to ensure that Unit 2 operation does not have an adverse affect on NPDES effluent limitations or other permit conditions. In the event the state determines that additional monitoring should be conducted, the results would need to be evaluated and submitted to the state per the conditions set forth. Potential changes in plant discharges are not expected to be significant as compliance with applicable regulatory safeguards and internal assessments would ensure that resulting effects to water quality are insignificant.

3.1.3. Groundwater

The 1995 FSER updated the groundwater information in the 1972 FES, and the descriptive information about groundwater systems in the vicinity of WBN provided in that update is still accurate. In August 2002, tritium was detected in one of the on-site environmental monitoring locations at levels that were just at the detectable level. At that time, TVA notified the NRC and State of Tennessee environmental and radiological representatives. To address this issue, in December 2002, TVA installed four new environmental monitoring locations on the plant site as a modification to the Radiological Environmental Monitoring Program. Since that time TVA has been closely monitoring in-ground tritium and reporting these results in the WBN Annual Radiological Environmental Operating Reports to NRC and the state of Tennessee.

Samples taken January 2003 through December 2004 indicated the presence of low levels of tritium in three of the four monitoring locations, which are maintained for environmental monitoring purposes only. The sources of this tritium were leakage from an underground radioactive effluent piping and leakage from a bellows for the Unit 2 fuel transfer tube. In order to stop the tritium ingress into the groundwater, the radioactive effluent piping was replaced with a new 4-inch pipe. In addition, the Unit 2 fuel transfer tube was sealed, and the fuel transfer canal was coated. These activities were completed by November 2005.

Results from two of the new individual sample locations, taken in February 2005 and June 2005, were greater than the NRC 30-day reporting level of 30,000 picocuries per liter (pCi/L). Further inspections revealed no leakage in underground radioactive effluent piping. TVA's investigation determined that the source of the increased tritium levels was a result of the previous effluent piping leak, which had been repaired. The highest amount of tritium detected was approximately 550,000 pCi/L.

Some residual tritium will remain in the groundwater until the tritium either decays or is diluted. Eventually, this groundwater will migrate into the river where these degraded tritium levels will be even further reduced and therefore pose no public health hazard. TVA continues to monitor wells monthly to verify past repairs and detect any new sources of contaminated groundwater. Routine reports are made to the NRC and the state.

Completion of WBN Unit 2 would not impact groundwater resources in the vicinity of WBN.

3.2. Aquatic Ecology

The characteristics of the WBN site's aquatic environment and biota were described in the 1972 FES (TVA 1972) with updated information described in the NRC 1995 FES (NRC 1995a) and the TVA 1998 FEA for the WBN SCCW Project (TVA 1998a). This information was based on site-specific data combined with general knowledge of Tennessee River tailwater habitats and associated aquatic biota. Extensive supplemental information specific to WBN is available from reports detailing results of the TVA Vital Signs Monitoring Program (TVA, unpublished data). These cited reports and data were examined and determined to continue to represent current environmental conditions adequately in the Watts Bar Dam tailwaters and upper Chickamauga Reservoir. They were used for the present FSEIS as a basis for a review of the aquatic ecology in the vicinity of the WBN site.

Plankton

Recent studies indicate that the majority of planktonic organisms (including fish eggs, larval fish, microinvertebrates, algae, etc.) in the vicinity of WBN originate in the Watts Bar Reservoir and pass through the turbines at Watts Bar Dam. Plankton density varies greatly from day to day. Sampling surveys (1973-1985) indicate that plankton populations decreased rapidly as distance from Watts Bar Dam increased due to the swift-flowing, riverine nature of the upper portions of Chickamauga Reservoir. As water enters the reservoir pool of Chickamauga Reservoir (25-30 miles downstream of WBN), velocities decrease and plankton densities gradually increase to levels comparable to those in the Watts Bar Dam forebay (TVA 1986).

Though there are no data on phytoplankton densities in the vicinity of the WBN site, comparisons between preoperational (1976-1985) and operational (1996-1997) densities of fish eggs and larval fish show similar patterns (Appendix C, Table C-1) (TVA 1998d). An entrainment study conducted during the spring and summer of 1975 estimated the average loss of fish larvae in the vicinity of WBF as a result of water diversion to the plant was 0.24 percent of the total population (TVA 1976b).

In the TVA FEA for the SSCW, TVA evaluated one-unit operation and concluded that the proposed project would result in loss of fish eggs and larvae through entrainment at approximately the same rate as previously studied in 1976 (TVA 1998a). Similar results were reported in the 2001 fish monitoring program for the SCCW and it was concluded that no significant impact to ichthyoplankton populations from WBN SCCW operation would occur (Baxter et al. 2001). These entrainment rates indicate the operation of both WBN Unit 1 and Unit 2 would have little or no effect on larval fish and egg populations in Chickamauga Reservoir because the WBN condenser cooling water system (CCW) is commensurate with a closed cycle cooling system.

Invasive and Noninvasive Aquatic Plants

Aquatic plants present in Chickamauga Reservoir include the invasive species Eurasian water milfoil (*Myriophyllum spicatum*), spinyleaf naiad (*Najas minor*), and the native southern naiad (*Najas guadalupensis*) (TVA 1994a). Excessive aquatic plant coverage can cause reservoir-use conflicts in areas around industrial water intakes, public access and recreation sites, and lakeshore developments. These effects have not been seen in the vicinity of WBN because the WBN site is located in the riverine tailwater area of the reservoir downstream of Watts Bar Dam. Aquatic plants have difficulty establishing dense growths in this area even during years of peak coverage due to current velocity. As a result, aquatic plant densities in the reservoir near WBN have not reached nuisance levels, and no control measures have been taken in the vicinity of the plant. Peak aquatic plant

coverage in Chickamauga Reservoir occurs in shallow, overbank lakelike habitat far downstream of WBN. Combined operation of WBN Units 1 and 2 would not have effects on the occurrence of invasive or noninvasive aquatic plants.

Aquatic Communities

Before 1978, fisheries biologists thought the tailwaters of Watts Bar Dam contained favorable spawning habitat for several species including sauger (*Stizostedion canadense*), smallmouth bass (*Micropterus dolomieu*), white bass (*Morone chrysops*) and possibly yellow perch (*Perca flavescens*). However, the evaluation of information in the 1978 NRC FES discounted this theory. Since 1978, additional studies have confirmed that the reach between the Watts Bar Dam and the WBN site is a staging area, not an area of significant spawning activity for these species (NRC 1995a).

TVA began a program to systematically monitor the ecological conditions of its reservoirs in 1990, though no samples were taken on the Watts Bar or Chickamauga Reservoirs until 1993. Previously, reservoir studies had been confined to assessments to meet specific needs as they arose. Reservoir (and stream) monitoring programs were combined with TVA's fish tissue and bacteriological studies to form an integrated Vital Signs Monitoring Program. Part of the monitoring consisted of the reservoir fish assemblage index (RFAI), a method of assessing the quality of the fish community. Since the institution of the Vital Signs Monitoring Program, the quality of the fish community in the vicinity of the WBN site has remained relatively constant with an average rating of "good" (see Appendix C, Tables C-2 and C-3).

Another aspect of the Vital Signs Monitoring Program is the benthic index, which assesses the quality of benthic communities in the reservoirs (including upstream inflow areas such as that around WBN). The tailwaters of Watts Bar Dam support a variety of benthic organisms including several large mussel beds. One of these beds has been documented along the right-descending shoreline immediately downstream from the mouth of Yellow Creek. To protect these beds, the state has established a mussel sanctuary extending 10 miles from TRM 520 to TRM 529.9. Since the institution of the Vital Signs Monitoring Program, the quality of the benthic community in the vicinity of the WBN site has remained relatively constant. The riverine tailwater reach downstream of Watts Bar Dam and WBN rated "good" in 2001 and the rating has increased to "excellent" in 2003-2005 (Appendix C, Tables C-4 and C-5).

Under the proposed action, no construction activities would occur within 500 feet of the reservoir, and all construction activities would be subject to appropriate BMPs to ensure that there are no impacts to surface water quality. NPDES discharge limits as outlined in the 1995 NRC FES and in this document would not be revised. No discharges exceeding current NPDES limits would occur during operation of WBN Units 1 and 2. The amount of cooling water required for operation of both WBN Unit 1 and WBN Unit 2 would result in increases in cooling water intake and discharge volumes, but thermal discharge rates would remain below maximum allowed levels outlined in the 1978 NRC FES (see section 3.1).

Because all construction work would be conducted using appropriate BMPs, and no additional discharge-related impacts would occur, there would be no effect on aquatic animals or their habitats in the vicinity of WBN. Because intake flows would not be increased above levels outlined in the 1978 NRC FES, fish entrainment rates would not exceed maximum levels previously evaluated in that FES for operation of both WBN Units 1 and 2.

Invasive and Exotic Aquatic Animals

At the time the 1972 FES was issued, the Asiatic clam (*Corbicula fluminea*) was the only benthic nuisance species known to occur in Chickamauga Reservoir. Subsequently, the zebra mussel (*Dreissena polymorpha*) has become established in the Watts Bar Dam tailwater area. The planktonic larvae of zebra mussels can be drawn into raw-water piping systems, and attach to pipe surfaces. Multiple layers of adult zebra mussels can accumulate resulting in partial to total blockage of pipes and grates. This can cause damage to pipes and facilities requiring facility outage time to remove the blockage. Currently, WBN has implemented the use of Clamtrol (WBN uses H150M), a nonoxidizing molluscicide, within the facility to inhibit biofouling by Asiatic clams and zebra mussels. However, this control method is restricted to the facility itself and concentrations of molluscicide released into the reservoir are too low to have any effect on native mussel beds (NRC 1995a).

3.3. Terrestrial Ecology

3.3.1. Plants

The terrestrial plant communities were assessed during the initial environmental review for the construction of WBN Units 1 and 2 (TVA 1972). Major plant community types are described and statistical values were calculated from data obtained from vegetation plot analyses from each terrestrial community. In addition, importance values along with frequency, density, basal area and volume for all tree species occurring on the Watts Bar reservation are presented. In the 1976 Environmental Information Report for WBN Units 1 and 2, the major community types are listed as oak-hickory forest, oak-gum forest, yellow pine-hardwood forest, Virginia pine forest, sumac shrub community, early old-field community, horseweed-type community, fescue meadow community, and a marsh community (TVA 1976a). Of the 967 acres identified for building WBN, 210 wooded acres were to remain undisturbed (approximately 80 percent of the existing woodlands). More than 70 percent of the plant area was already disturbed in the form of cultivated or old fields.

The terrestrial plant communities of the WBN site have changed very little over the past 34 years. The majority of the project area (over 70 percent) is composed of herbaceous vegetation types found in old fields, gravel parking areas, roadside rights-of-way and various other disturbed sites. Approximately 30 percent of the site is still forested with the following forested vegetation classes: deciduous forest and evergreen-deciduous forest. The deciduous forest can be characterized as two separate community types, oak-hickory forest and bottomland hardwood forest. Invasive species including Japanese stilt grass, Japanese honeysuckle, multiflora rose, and Russian olive occur on WBN Reservation.

Some disturbance of existing plant communities may occur if construction of WBN Unit 2 recommences although most construction activities are expected to occur in already constructed buildings or within the previously disturbed plant footprint. Because no uncommon terrestrial communities or otherwise unusual vegetation occurs on the lands to be disturbed under the proposed action, impacts to the terrestrial ecology of the region are expected to be insignificant as a result of the proposed actions. No new infestations of exotic invasive plant species are expected as a result of the Action Alternative.

3.3.2. Wildlife

The terrestrial ecology at the WBN facility has changed little from those described in earlier environmental reviews. Habitats surrounding the facilities consist of mowed grass, fields of short vegetation, and ditches that are intermittently wet. The project site, which is highly developed, includes parking areas and ball fields in addition to these habitats.

Wildlife using these areas, primarily adjacent to the disturbed area footprint, include locally abundant species that are tolerant of human activity and highly modified habitats. Species such as eastern meadowlark, American goldfinch, eastern bluebird, and song sparrow were observed at or adjacent to the proposed project site. Spotted sandpiper and killdeer were observed in or near the settling ponds at the facility; most of these ponds are lined with riprap and provide poor habitat for shorebirds. However, species including double-crested cormorants, mallards, Canada geese, black vultures, rock pigeons, and white-tailed deer were noted near the ponds. An osprey nest was also observed on a nearby structure.

Due to the overall lack of wildlife habitat at the project site and the limited amount of additional habitat disturbance anticipated, the proposed project is not expected to result in adverse impacts to terrestrial animal resources within the disturbed area footprint (Figure 1-2) or in the adjacent areas. Wildlife in the project area is locally abundant and no rare or uncommon habitats exist at the site.

3.4. Threatened and Endangered Species

As discussed in Sections 3.2 and 3.3, most of the aquatic and site disturbance required for completion of WBN Unit 2 has already occurred. The following sections provide an update of the federally listed and state-listed species found in the vicinity of the WBN site and the potential for impacts from the proposed action.

3.4.1. Aquatic Animals

Four mussel species federally listed as endangered, dromedary pearlymussel, pink mucket, rough pigtoe, and fanshell, are known to occur in mussel beds in the vicinity of WBN (Appendix C, Table C-6). To protect these beds, the state has established a mussel sanctuary extending 10 miles from TRM 520 to TRM 529.9 (Appendix C, Table C-7) (TVA 1998b). Figure 3-4 shows the location of the mussel sanctuary relative to WBN.

The snail darter, federally listed as threatened, is also known to occur occasionally in this reach of the Tennessee River. The majority of the snail darter population in the area is confined to Sewee Creek, a tributary to the Tennessee River, which enters the river at TRM 524.6.

The larvae of snail darters are pelagic and can drift substantial distances (miles) during early life stages. Spawning of snail darters has not been documented in the main stem of the Tennessee River downstream of Watts Bar Dam, and no snail darter larvae have been collected during entrainment sampling.

Two mussel species considered sensitive by the State of Tennessee; pyramid pigtoe and Tennessee clubshell, and one state-listed threatened fish species; blue sucker, are also known from this reach of the Tennessee River (Appendix C, Table C-6).

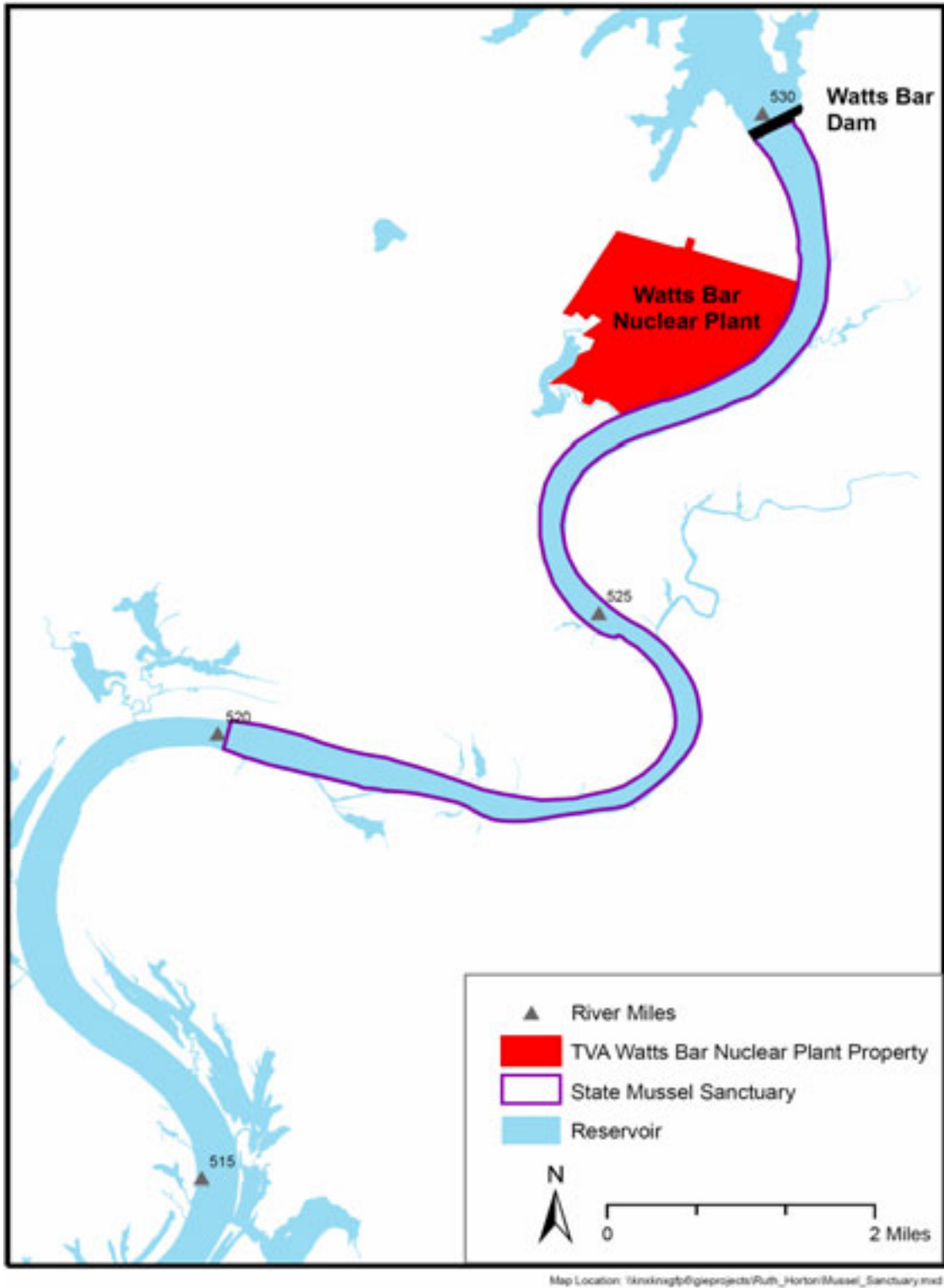

Figure 3-4. Location of Mussel Sanctuary in Chickamauga Reservoir Below Watts Bar Dam

Under the proposed action, work would be conducted on WBN Unit 2 in order to bring it to full operational capacity. No construction activities would occur within 500 feet of the reservoir, and all construction activities would be subject to appropriate BMPs to ensure that there are no impacts to surface water quality. NPDES discharge limits as outlined in the 1995 NRC FES would not be revised. No discharges exceeding current NPDES limits would occur during operation of WBN Units 1 and 2. The amount of cooling water required for operation of both WBN Unit 1 and WBN Unit 2 would result in increases in cooling water intake and discharge volumes up to the original two-unit design. Thermal discharge rates would remain below maximum allowed levels outlined in the 1978 NRC FES.

The steam generator blowdown (SGDB) contains low levels of ammonia, which is injected in the turbine building to control corrosion. The highest concentration of ammonia measured in the SGDB during the past four years was 4.2 mg/l (or 4.2 ppm). The maximum SGDB discharge for Units 1 and 2 would be 524 gallons per minute (gpm) through the diffusers at outfall 101 and would require 3500 cfs of minimum riverflow. Based on the hydrothermal analysis in Section 3.1 and previous diffuser studies (Hadjerioua, et.al. 2003), in the worst case conditions, ammonia concentrations would be fully mixed prior to reaching the stream bottom in the 240-foot wide by 240-foot-long assigned mixing zone. SGDB is diverted to the yard holding pond with cooling tower blowdown when the minimum river flow of 3500 cfs is not available, unless it has already been diverted to the condensate system. When the minimum riverflow of 3500 cfs is available, the YHP discharges through outfall 101. The YHP has an emergency overflow that discharges through outfall 102. In general, the operation of Watts Bar Dam and the WBN blowdown system are very carefully coordinated so that there are no unexpected overflows from the yard holding pond. (see Section 2.2.2). No events with overflow from the YHP occurred during the hydrothermal analysis described in Section 3.1, therefore under operating conditions, releases from Outfall 102 are not expected. Therefore, there would be no effect to any federally listed as endangered or threatened mussels.

Because all construction work would be conducted using appropriate BMPs, and no additional discharge-related impacts would occur, there would be no effect on state-listed or federally listed aquatic animals or their habitats in the vicinity of WBN. Because intake flows would not be increased above levels outlined in the 1978 NRC FES, fish entrainment rates would not exceed maximum levels previously evaluated in that FES for operation of both WBN Units 1 and 2. Because snail darter larvae have not been encountered in entrainment sampling at WBN, there is no potential for snail darter larvae to be entrained at the cooling water intake for WBN even under the increased withdrawal rates required to support operation of both WBN Units 1 and 2.

3.4.2. Plants

Historically, one plant species, spider lily, *Hymenocallis occidentalis* (now *H. carolinensis*), was identified as being a proposed rare and endangered species by the USFWS in the original FES (TVA 1972). This designation was made prior to the Endangered Species Act of 1973, and the species was not listed as threatened or endangered under this act nor is it given any special status within the state of Tennessee. In addition, field surveys in 1994 failed to find any populations of spider lilies in the vicinity of WBN (TVA 1995a; 1995b). The FEA for the WBN Unit 1 Replacement of Steam Generators documents six Tennessee state-listed plant species known from within 5 miles of WBN, and no sensitive plant species or habitat to support these species were found during field reviews (TVA 2005a).

The six Tennessee state-listed plant species known from within 5 miles of WBN are shown in Table 3-12. There are no known federally listed as threatened or endangered plant species within Rhea County, Tennessee. No designated critical habitat for plant species are known from within 5 miles of WBN or Rhea County.

Table 3-12. State-Listed Plant Species Reported From Within 5 Miles of the Proposed Project in Rhea County, Tennessee

Common Name	Scientific Name	State Status/Rank
Appalachian bugbane	<i>Cimicifuga rubrifolia</i>	THR (S3)
Heavy sedge	<i>Carex gravida</i>	SPCO (S1)
Northern bush honeysuckle	<i>Diervilla lonicera</i>	THR (S2)
Prairie goldenrod	<i>Solidago ptarmicoides</i>	END (S1S2)
Slender blazing star	<i>Liatris cylindracea</i>	THR (S2)
Spreading false foxglove	<i>Aureolaria patula</i>	THR (S3)

Status abbreviations: END=Endangered, SPCO=Species of special concern, THR = Threatened, S1 = critically imperiled with 5 or fewer occurrences; S2 = imperiled with 6 to 20 occurrences, S3 = Rare or uncommon with 21 to 100 occurrences

No occurrences of state-listed or federally listed plant species are known on or immediately adjacent to the area to be disturbed under the proposed Action Alternative. Therefore, no impacts to sensitive plant species are expected.

3.4.3. **Wildlife**

Earlier reviews indicated that federally listed as threatened or endangered gray bats (*Myotis grisescens*) and bald eagles (*Haliaeetus leucocephalus*) were reported within 5 miles of the project. Small numbers (less than 500) of gray bats continue to roost in a cave approximately 3.3 miles from the project. Bald eagles nest on Chickamauga and Watts Bar Reservoirs approximately 1.8 and 4.7 miles, respectively, from the project site. Gray bats and bald eagles forage over the Tennessee River in the vicinity.

Several heron colonies have been reported from the vicinity since the late 1980s. Many of these colonies were destroyed during recent pine beetle infestations. The closest active colony is located 4 miles north of WBN.

Hellbenders (*Cryptobranchus alleganiensis*), listed as in need of management by the State of Tennessee, have been reported from the upper reaches of Sewee Creek, approximately 2.5 miles from the project site. The species may continue to inhabit streams in the vicinity.

Completion of WBN Unit 2 is not expected to result in impacts to any federally listed or state-listed as threatened or endangered species of terrestrial animals or their habitats. No suitable habitat for gray bats or bald eagles exists on or adjacent to the project site. Construction and operation of WBN Unit 2 would not result in impacts to bald eagles and gray bats in the region.

3.5. Wetlands

Wetland communities were assessed during the initial environmental review for the construction of WBN Units 1 and 2 (TVA 1972), and were also assessed for the construction of various other operational components of the site (TVA 1995a; TVA 1995b; TVA 2005a). Forested wetlands are present on the southwest portion of the site, and emergent wetlands have developed within ash disposal sites and in containment ponds located in the southwest portion of the site. Scattered areas of fringe emergent wetlands are present along the shoreline of the WBN site, and there are small areas of forested, scrub-shrub, emergent wetlands associated with streams on the plant site.

A field survey for wetlands conducted on October 30, 2006, indicated a forested wetland is present adjacent to the project footprint. This wetland is associated with an unnamed stream between the road and the rail line just outside of the northeast corner of the project footprint. The area is approximately 1 acre in size; dominant vegetation includes tag alder, sycamore, and black willow. The remainder of the site is composed of upland plant communities, gravel parking areas, and developed areas.

Since there are no plans to disturb the above-mentioned forested wetland, no impacts to wetlands would occur as the result of construction activities related to the completion of WBN Unit 2. If project plans are modified and impacts to this wetland are unavoidable, mitigation may be required as a condition of state and/or federal wetland protection regulations (Section 404, Clean Water Act, and Aquatic Resources Alterations Permit). Mitigation may consist of off-site mitigation in the form of wetland creation or purchase of credits in a wetland mitigation bank. Overall impacts to wetlands in the project area would be insignificant due to the small size and limited ecological function of the wetland.

3.6. Natural Areas

Changes (since the 1978 NRC FES; NRC 1995b; and TVA 1998a) in natural areas and the environmental impact on natural areas within 3 miles of WBN are assessed below for the purpose of updating previous documentation to current conditions.

Three of five natural areas currently listed in the Natural Heritage database and within 3 miles of WBN were reviewed in previous documents. These areas are Yellow Creek unit of the Chickamauga State Wildlife Management Area (WMA), the Chickamauga Reservoir State Mussel Sanctuary, and the Chickamauga Shoreline TVA Habitat Protection Area (HPA). TVA 1998a found no direct or indirect effects to Yellow Creek WMA or the TVA HPA. NRC 1995b, which reviewed the 1978 NRC FES, noted no significant changes in, and therefore no significant impacts to, the aquatic environment in the vicinity of WBN. Additionally, no impacts to the mussel sanctuary (an area designated by the State of Tennessee to be a biological preserve for mussel species) are anticipated from the proposed action (Stephanie Chance, TVA, personal communication, November 14, 2006). No significant changes in area or management objectives of the WMA and TVA HPA have occurred since they were last reviewed, and therefore, no direct or indirect impacts to these areas are anticipated from the proposed action.

Two additional natural areas within 3 miles of WBN include Meigs County Park, a 240-acre public recreation area approximately 1.5 miles north of the site, and Yuchi Wildlife Refuge at Smith Bend, a 2600-acre haven for migratory waterfowl and shorebirds. This refuge, managed by the Tennessee Wildlife Resources Agency, is approximately 2.2 miles south of the site. The

distance from the site to these two areas is sufficient such that no direct or indirect impacts are anticipated.

3.7. Cultural Resources

As part of the extensive history of environmental review of constructing and operating WBN, TVA has considered the potential impact on historic and archaeological resources associated with each undertaking. It was determined during the initial environmental review that two archaeological sites (40RH6 and 40RH7) would be adversely affected by construction of the plant. Based on this finding, TVA proceeded with data recovery of these sites (Calabrese 1976; Schroedl 1978). One historic cemetery (Leuty Cemetery) was located on the property prior to plant construction. Two graves were removed in 1974 and placed in Ewing Cemetery. Subsequent environmental reviews conducted resulted in a "no-effect finding" for archaeological resources. In the 1998 review of the WBN SCCW project (TVA 1998a), TVA determined that WBF was eligible for listing on the National Register of Historic Places (NRHP). However, it was determined that this property would not be adversely affected.

Four archaeological sites are located within the WBN property (40RH6, 40RH7, 40RH8, and 40RH64). The first three sites were recorded as part of the Watts Bar Basin survey in 1936. The latter was recorded later during a post-inundation Chickamauga Reservoir shoreline survey. While a portion of these sites was excavated, the sites remain eligible for listing on the NRHP with a potential for significant archaeological deposits and features to be present. Sites 40RH8 and 40RH64 are both considered potentially eligible for listing on the NRHP. While a reconnaissance survey was conducted on the plant property prior to its construction, archaeological survey techniques have significantly improved since that time. Based on what we already know, undisturbed areas outside the current project's area of potential effect (APE) have a high potential for archaeological resources to be present. Any future ground-disturbing activity in these areas would have to be reviewed.

A majority of the APE for this project has been extensively disturbed. Completing WBN Unit 2 would result in some additional ground-disturbing activities but largely would be restricted to the existing disturbed portion of the plant property. A field visit conducted confirmed the prior disturbance in these areas. Project plans submitted include a larger footprint surrounding the plant that has been identified as the "disturbance area." A portion of this footprint east of the cooling towers (the avoidance area shown on Figure 3-5) includes parts of archaeological site 40RH6 and it is unknown if this site contains significant archaeological deposits. Although this site is within the area identified as potentially to be disturbed, current plans actually would not disturb it. If those plans change and this area would be disturbed, an archaeological survey of the affected area would be conducted to determine the significance of the site and if determined to be archaeologically significant, appropriate measures would be taken to avoid adversely impacting identified resources. This would include coordination with the SHPO.

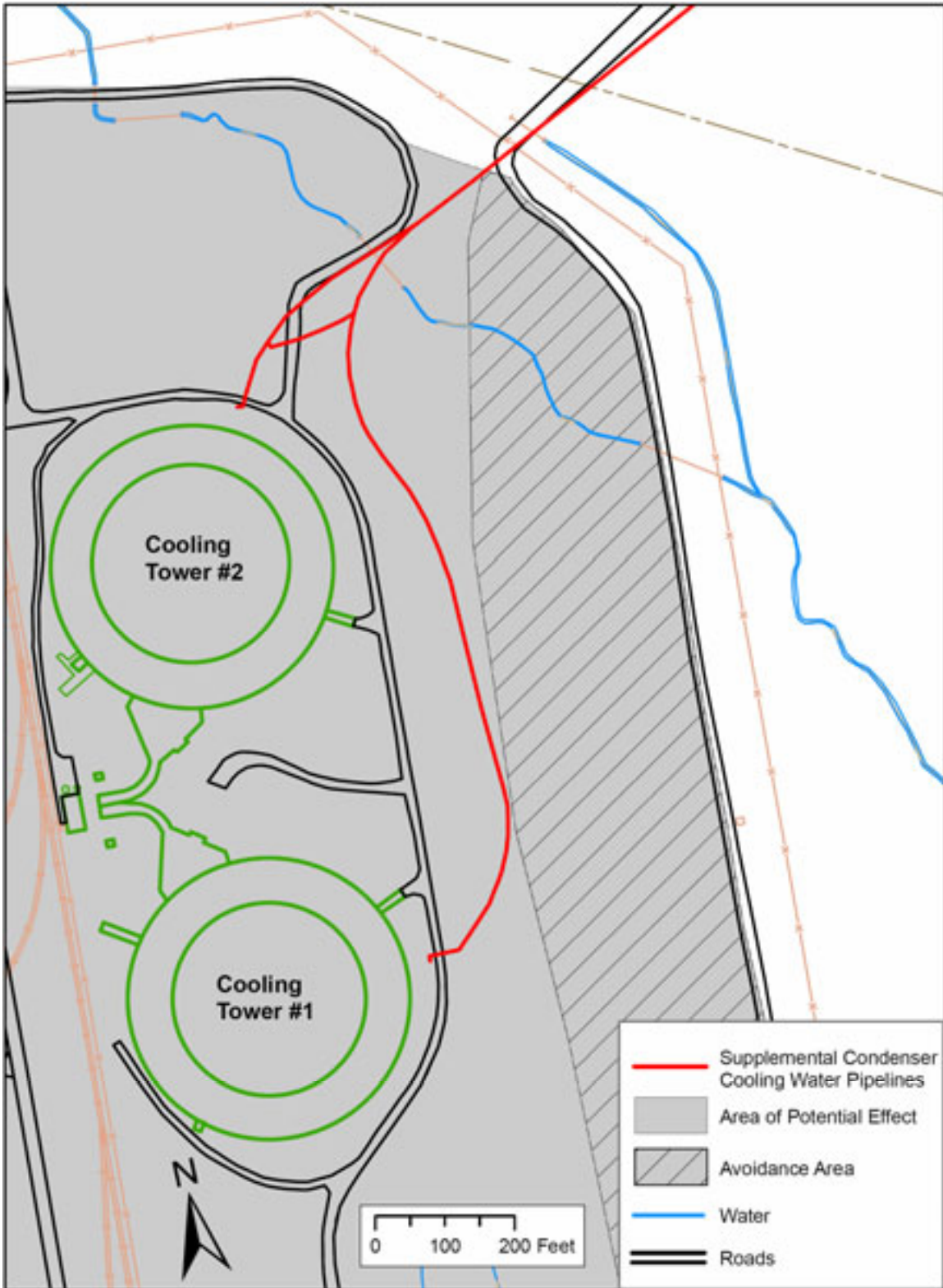

Figure 3-5. Archaeological Avoidance Area Within the Area of Potential Effect

As planned, archaeological resources within the APE at WBN should not be adversely affected by this action. TVA is coordinating with the SHPO for concurrence with this finding.

3.8. Socioeconomic, Environmental Justice, and Land Use

3.8.1. Population

The 1972 FES on WBN Units 1 and 2 estimated the 1970 population within 10 miles of the site to be 10,515. Rhea County, in which the plant is located, and Meigs County which is located just east of the site across the river, were both slow growing, with a total net population growth of 400 between 1960 and 1970. This information was updated and expanded for the 1978 NRC FES. While the 1972 FES projected population by the year 2000 to be 11,995 within 10 miles of the site and 1,028,345 within 50 miles, the 1978 NRC FES had slightly lower projections of 10,770 within 10 miles and 950,461 within 50 miles. In 1995, NRC and TVA provided estimates for 1990 and projections for 2040 (1995 NRC FES, and 1995 FSER). For 1990, population within 10 miles was estimated to be 15,842, and within 50 miles, 862,465. Projections for 2040 were a total population of 17,854 within 10 miles and 1,066,580 within 50 miles.

Based on the 2000 Census of Population, the population for 2000 is estimated to be 16,392 within 10 miles and 1,064,513 within 50 miles, indicating that the area around the site has been growing faster than projected. Based on these trends, the population in 2040 is projected to be about 29,300 within 10 miles and 1,519,000 within 50 miles, a much higher growth rate than in earlier projections.

Since the earlier reports were prepared both Rhea and Meigs Counties, as well as most of the surrounding counties, have seen a substantial increase in population growth rates. Rhea County increased by only about 0.4 percent from 1980 to 1990, but by 16.7 percent from 1990 to 2000. Meigs County experienced a similar increase in growth rate, from 8.1 percent between 1980 and 1990 to 38.0 percent between 1990 and 2000. Fast-growing areas in Meigs and Rhea Counties include much of the area near the Tennessee River, on both sides, and the area to the east toward Athens, Tennessee. Increases from 1990 to 2000 in surrounding counties within the 50-mile range varied from 4.5 percent in Anderson County to 34.7 percent in Cumberland County. Population estimates for 2005 show continuing growth in the area and specifically in Rhea and Meigs Counties, but at a somewhat slower rate than during the 1990s.

During construction, population would increase due to the influx of workers. At peak construction employment, the total construction and design employment could be as high as 3000; however, many of these are engineers, nonmanual craft, and other workers who likely would not relocate to the site. TVA is conducting a more detailed study of construction requirements, which will provide a more precise estimate. For this analysis, a conservative estimate is made by assuming that the peak on-site workforce would be 2200. Based on previous experience at the site, it is assumed that 40 percent of these would move into the area. Given this assumption, the total number of movers would be 880. The remaining 60 percent or more of the workers would either be local residents or would commute from the surrounding area, including the Chattanooga and Knoxville areas. Impacts of this increase in population should be similar to those described in the earlier documents referenced above.

Based on experience during construction at Unit 1 from 1982 to 1986, about two-thirds of the in-moving workers would move into Rhea and Meigs Counties due to their proximity to the site. Most of the others would locate in readily accessible locations such as McMinn and Roane Counties, and a small number to Knox or Hamilton Counties and other nearby areas. Actual locations would, of course, depend on the availability of housing or of sites for recreational vehicles (RVs) and trailers. The widespread distribution of the residential location of workers, including those who move into the area, would lessen the impacts. Overall, this influx should be similar to what occurred during the mid-1980s with earlier construction at the site, except that the number of workers is expected to be slightly lower than during much of the earlier construction.

3.8.2. *Employment and Income*

The earlier studies noted that the immediate vicinity of the plant, Rhea and Meigs Counties, had been experiencing employment growth, in particular industrialization. The latest employment data suggest that these counties have been able to retain their industrial competitive edge. While the nation, the state, and almost all of the counties within the 50 mile area around the plant experienced substantial decreases in manufacturing employment between 1995 and 2005, Meigs County had a small increase (from 697 to 741) and Rhea County a very small increase (from 4701 to 4711). The average decrease for all the counties within the 50-mile area was 20.7 percent, while the state decreased by 23.3 percent and the nation by 22.5 percent. Private employment other than farm and manufacturing generally had significant increases throughout the area, as in the state and in the nation.

The 1995 NRC FES noted that real income in Meigs and Rhea Counties continued to grow. This trend has continued since that time, with per capita personal income in 2005 in Meigs County, 51.3 percent higher than in 1995, and in Rhea County, 40.2 percent higher. In contrast, the Consumer Price Index increased by 28.1 percent during this time. The growth rate of income in the 50-mile area was 44.4 percent. Most of these rates, however, are lower than the state and national averages of 46.3 and 49.4 percent, respectively.

Much of the income received by these workers on the WBN Unit 2 project would be spent in the area, especially by those who move families into the area and those who are already residents. This would increase income of businesses in the area, especially those oriented directly to consumers, and could lead to a small temporary increase in employment. After construction is completed, there would still be some increase in income and employment in the area from operation of Unit 2, although the size of the increase would be much smaller.

3.8.3. *Low-Income and Minority Populations*

In Rhea and Meigs Counties in 2000, the minority population was 5.4 and 2.7 percent, respectively, of the total population. Within 10 miles of the site, the average was 3.5 percent and within 50 miles, 11.5 percent. Minority population in the area of Rhea County immediately around the site in 2000 was 2.7 percent of total population (Census Tract 9751, Block Group 2) and was 4.5 percent in the area of Meigs County immediately across the Tennessee River (Census Tract 9601, Block Group 2). In both block groups, the minority population is somewhat geographically distributed, not highly concentrated in one location. All of these averages are well below the state average of 20.8 percent and the national average of 30.9 percent.

According to the 2000 Census of Population, the poverty level in Rhea County is 14.7 percent and in Meigs County, 18.3 percent. These rates are higher than both the statewide rate of 13.5 and the national rate of 12.4 percent. The county rates show decreases from rates 10 years earlier of 19.0 and 22.3 percent; the total of persons below the poverty level decreased from 4476 to 4042 in Rhea County and increased from 1761 to 2000 in Meigs County. The most recent estimates, for the year 2004, show a poverty level in Rhea County of 16.2 percent and in Meigs County, 17.5 percent; given the confidence levels of the estimates, little or no change seems to be indicated since the 2000 Census. Poverty levels within the 10-mile area around the plant are slightly higher than both the state and national levels, with a poverty rate estimated to be about 15.1 percent among those who live within 10 miles of the site and 11.8 percent within 50 miles. Based on the 2000 Census of Population, the poverty level in the area immediately around the site (Rhea County, Census Tract 9751, Block Group 2) is 18.1. This was a decrease from 19.0 percent 10 years earlier, although the number of persons below the poverty level increased from 237 to 282. In the area immediately across the river (Meigs County, Census Tract 9601, Block Group 2) the poverty level is 21.7 percent. This was an increase from 19.2 percent 10 years earlier and an increase in the number of persons below poverty from 184 to 333. Within the 10-mile area around the site, the poverty level decreased from 16.2 percent in 1989 to 15.1 percent in 1999, increasing from about 3300 persons to about 3800. This decrease (1.1 percentage points) was greater than the national decrease of 0.7 percentage points, but less than the statewide decrease of 2.2 percentage points. Thus, the poverty levels in the area around the site have been declining, as have the rates statewide and nationally, while the number of persons in poverty has continued to increase in some of the areas around the site as it has statewide and nationally. However, the overall poverty level in the area is still above the state and national averages and also above the level for the 50-mile area around the site.

The low minority population share, along with the diffused nature of potential negative impacts, makes it unlikely that there would be disproportionate impacts to minority or low-income populations. However, such impacts are possible, particularly impacts arising from housing needs and increased traffic during the construction period. TVA would work with local representatives and officials to help reduce impacts from these sources by providing more detailed information about the anticipated workforce. A mitigating action could be identification of the area as an impact area under the existing state tax code (see Section 3.8.7). This would allow more of the tax equivalent payments that TVA annually makes to Tennessee to be allocated to these counties.

3.8.4. *Housing and Community Services*

Both Rhea and Meigs Counties have experienced notable increases in the number of housing units in recent years. This increase from 1990 to 2000 was 2204 housing units, 21.3 percent, in Rhea County and 1499 units, 40.6 percent, in Meigs County. Both counties experienced a higher rate of increase than the state as a whole, which increased by 20.4 percent. This growth may result in more difficulty in finding sites for temporary housing, such as RVs and trailers. However, the temporary influx of workers during construction would be spread out among not only Rhea and Meigs Counties, but nearby counties also, especially those within 30 to 35 miles away. In addition, many of the workers would be commuting from their existing homes in this area or slightly farther away, especially the Chattanooga and Knoxville areas. The result would be some increase in temporary housing needs, including apartments and facilities for trailers and RVs. To the extent that the pattern from construction in the 1980s is followed, Rhea and Meigs likely would see

close to 600 temporary workers locating in those two counties; of these, about three-fourths would bring families with them. At that time, families on the average had about 1.3 children, making an average family size of 3.3. Families, especially those with children, would be more likely to look for houses or apartments while workers moving alone may be more likely to bring trailers or RVs with them or to rent trailers or small apartments. Many, especially those whose work is likely to continue through most of the construction period, are likely to look for houses to purchase. The result of this increased demand for temporary housing and for locations for RVs and trailers would be noticeable, especially in Rhea and Meigs Counties. TVA would work with local representatives and officials to help reduce impacts by providing more detailed information about the anticipated workforce. A mitigating action could be identification of the area as an impact area under the existing state tax code (see Section 3.8.7).

Community services such as health services, water and sewer, and fire and police protection would also be impacted. While Rhea and Meigs Counties likely would feel the greatest impact, nearby counties would also be impacted. These impacts should be similar to those that occurred earlier with construction of Unit 1 at the site, which were projected to have no adverse effects. After construction is completed, there would be an increase of approximately 150 in permanent employment at the site; this increase would be small enough that the community could accommodate it with no noticeable impacts.

3.8.5. Schools

As noted above, Rhea and Meigs Counties most likely would be the residential location of roughly two-thirds of the workers who move into the general area to work at the site. If the location patterns and mover characteristics of workers during construction of Unit 1 in the 1980s is followed, there would be an increase of approximately 660 school-age children in the broader area around the site, of which an estimated 434 likely would reside in Rhea and Meigs Counties. Total public school enrollment in these two counties is approximately 6800. There is some capacity for certain grade levels in some of the schools. However, the systems overall are at or near capacity, and in some cases over capacity, such as at Rhea County High School and in some lower grade levels in Rhea County. The schools in these counties have been experiencing a steady growth in enrollment for several years, and this growth is expected to continue. Additional growth due to an influx of construction workers would increase the overcrowding already being experienced. TVA would work with local representatives and officials to help reduce impacts by providing more detailed information about the anticipated workforce. A mitigating action could be identification of the area as an impact area under the existing state tax code (see Section 3.8.7).

3.8.6. Land Use

Land use in the area around the site was discussed in earlier studies, particularly in the TVA 1972 FES. Since that time, the same general pattern of land use and land use change has continued, with significant increases in land used for housing and for commercial purposes, along with ongoing decreases in open space and land used for farming. Completion and operation of Unit 2 are not likely to have a major impact on this trend, although it might accelerate it slightly. As discussed above, the number of construction workers and their families that would locate in the area during the construction period is expected to be less than 2000.

3.8.7. Local Government Revenues

Under Section 13 of the TVA Act, TVA makes tax equivalent payments to the State of Tennessee, with the amount determined 50 percent by the book value of TVA property in the state and 50 percent by the value of TVA power sales in the state. In turn, the state redistributes 48.5 percent of the increase in payments to local governments. Payments to counties are based on relative population (30 percent of the total), total acreage in the county (30 percent), and TVA-owned acreage in the county (10 percent). The remaining 30 percent is paid to cities, distributed on the basis of population. In 2006, tax equivalent payments to Rhea County were \$724,050 and to Meigs County, \$484,465. Completion of WBN Unit 2 would increase book value of TVA property in the state and would, therefore, increase tax equivalent payments to the state. This increase would be distributed in part to local governments as described above, resulting in a small increase in payments to Rhea and Meigs Counties.

During construction, Tennessee law (Tennessee Code Annotated [TCA], §67-9-101) provides for allocation of additional payments to impacted local governments from the TVA tax equivalent payments. These additional payments would be made to the local governments, upon designation by TVA of these areas as impacted areas, and would continue throughout the construction period. Payments would continue to be made in decreasing amounts for three years afterward. The actual amount paid would be determined by the state comptroller of the treasury, based on the provisions of TCA §67-9-102(b). The additional payments from state allocation of TVA tax equivalent payments to these local governments during construction could be used to address some of the impacts on public services discussed above.

In addition, there would be additional tax revenue associated with expenditures made in the area for materials associated with the proposed plant completion as well as sales tax revenue associated with purchases by individuals employed during construction and subsequently during operation. The magnitude of these increases could vary greatly, depending on the amount of local purchases for construction and on the relocation and buying decisions of workers employed at the site.

3.8.8. Cumulative Effects

No cumulative socioeconomic effects were identified in earlier WBN-related environmental reviews. The major change in the area's socioeconomic environment since those earlier documents were prepared is the more rapid population growth the area has seen and is expected to continue to experience, especially in the areas along the Tennessee River in Rhea and Meigs Counties (Section 3.8.1). Much of this area is sparsely populated and capable of supporting additional growth. Along with this population growth, the area economy is diverse and growing; however, this growth has resulted in some impact to community services, most notably in increased overcrowding in certain public schools. The increase from the influx of workers during construction of WBN Unit 2 would temporarily add to these impacts, especially to the school systems in Rhea and Meigs Counties.

TVA is currently updating the draft land plan and draft environmental impact statement (TVA 2005d) for Watts Bar Reservoir. TVA plans to issue an amended DEIS for the Watts Bar Reservoir Land Management Plan in the summer of 2007. In the event that nearby TVA land is allocated for industrial or recreational development in the revised land plan, potential cumulative effects from subsequent development in conjunction with construction

or operation of WBN Unit 2 would be addressed when proposals for development are reviewed.

The extent of the impact overall and on individual school systems and schools is largely dependent on where in-moving workers locate their residences. The recent growth that has occurred, along with the expected continuation of this growth, could result in location patterns different in some ways from the patterns associated with earlier construction at the site. For example, some of the in-coming workers might locate farther away from the site than they would prefer. This could have the effect of decreasing the number locating in Rhea and Meigs Counties, or parts of these counties, and increasing the number in some nearby counties. Improved roadways in the area, as contrasted to earlier construction periods, may also make location at greater distances relatively more attractive, increasing the tendency to locate farther from the site. In addition to schools, other community services could be impacted by the temporary influx of construction workers in conjunction with the current growth pattern. These impacts are likely to be less noticeable than the school impacts. Additional road traffic at peak times, given the combination of construction workers and the growth of permanent population, could cause a noticeable impact at some locations. There could also be noticeable impacts to other community services such as medical facilities and public safety. The extent of all these cumulative impacts would depend greatly on the residential locations of the in-moving workers. As noted above, TVA is conducting a labor study, the results of which will be provided to officials in the impacted counties to help with local planning to accommodate the anticipated impacts. In addition, TVA would work with the local communities to facilitate planning for these potential impacts.

3.9. Floodplains and Flood Risk

In the TVA 1972 FES for WBN Units 1 and 2, a letter was included to Mr. Gartrell, with the U.S. Department of the Interior, regarding siting of these units. The letter states: “Plant Siting--The Geological Survey is reviewing geologic and hydrologic data relevant to WBN Units 1 and 2, as supplied by TVA in a preliminary safety analysis report (PSAR) to the AEC. This review pertains to geologic and hydrologic aspects of the site such as earthquake effects, foundation conditions, and flooding potential.” The PSAR became the FSAR on June 30, 1976, with the submittal of amendment 23 (TVA 1976c). The FSAR contains information related to potential flooding of the Watts Bar site from the Tennessee River and local probable maximum precipitation⁴ (PMP) site drainage and is still current. Section 3.7 Floodplains and Flood Risk of the FEA for the WBN Unit 1 Replacement of the Steam Generators describes the current conditions at WBN (TVA 2005a).

WBN is located on the right bank of Chickamauga Reservoir between TRM 528.0 and 528.6 in Rhea County, Tennessee. The area potentially impacted by this project would extend from about TRM 528.4 to 529.0. The proposed project area could possibly be flooded from the Tennessee River and local PMP site drainage.

⁴ The Probable Maximum Precipitation is defined as the theoretically greatest depth of precipitation for a given duration that is physically possible over a particular drainage area at a certain time of year (American Meteorological Society, 1959). In consideration of the limited knowledge of the complicated processes and interrelationships in storms, PMP values are identified as estimates.

The 100-year floodplain for the Tennessee River would be the area below elevation 697.3 feet above mean sea level (msl) at TRM 528.4 and elevation 697.6-feet msl at TRM 529.0. The Tennessee River TVA flood risk profile (FRP) elevation would be elevation 701.1-feet msl at TRM 528.4 and 701.4 at TRM 529.0. The FRP is used to control residential and commercial development on TVA lands and flood damageable development for TVA projects. In this area, the FRP elevations are equal to the 500-year flood elevations.

Under current conditions, the estimated Tennessee River Probable Maximum Flood⁵ (PMF) level would be elevation 734.9-feet msl at WBN. Consequent wave run-up above the flood level would be 2.0 feet, which would produce a maximum flood level of elevation 736.9-feet msl (TVA 2004d). Based on site topography, much of the proposed project area would be inundated at this elevation. It has previously been determined that the critical elevation for PMP site drainage should be no higher than elevation 729.0-feet msl.

The floodplains and flood risk assessment involves ensuring that facilities would be sited to provide a reasonable level of protection from flooding. In doing this, the requirements of Executive Order 11988 (Floodplain Management) would be fulfilled. Due to the fact that the proposed project could potentially impact flood elevations at several buildings at a nuclear generating facility, the NRC requires a flood risk evaluation of possible impacts from the PMF and PMP site drainage for all alternatives.

The following proposed activities could be impacted by flood conditions: material handling buildings, materials storage building, a multipurpose building, a new construction access facility, temporary outage building, and an in-processing center would be constructed; temporary craft trailers would be added; and temporary parking and laydown areas would be developed. All proposed facilities would be located outside the limits of the Tennessee River 100- and 500-year floodplains, but many of the proposed structures would be located on ground below the Tennessee River PMF elevation of 734.9-feet msl. For those structures located below the Tennessee River PMF, an acceptable level of flood risk would be provided because the probability of flooding would be extremely low, and flooding of these structures would not impact the safe operation of the plant. None of the proposed activities would result in changes to the Tennessee River PMF elevation.

All existing safety-related facilities, systems, and equipment are housed in structures that would provide protection from flooding for all flood conditions up to plant grade at elevation 728-feet msl. Other rainfall floods would exceed plant grade elevation 728-feet msl and require plant shutdown. However, flood warning criteria and forecasting techniques have been developed to assure that there will always be adequate time to shut the plant down and be ready for floodwaters above plant grade (TVA 2004d).

The placement of temporary and permanent structures both inside and outside the security fence would be required to complete Unit 2. The tentative locations of the proposed new structures are shown on the site plan (Figure 1-2). The building numbers in the following analysis correspond to the legend of Figure 1-2. The material handling buildings (2), materials storage building (4), and in-processing center (32) would be located outside of the

⁵ The Probable Maximum Flood is defined as the most severe flood that can reasonably be predicted to occur at a site as result of hydrometeorological conditions. It assumes an occurrence of PMP critically centered on the watershed and a sequence of related meteorologic and hydrologic factors typical of extreme storms.

security fence. These structures would not be located within critical areas for PMP site drainage and would not adversely impact PMP site drainage elevations.

The new multipurpose building (28) and temporary craft trailers (29) are both within the area defined as “Area East of Main Plant” in the site drainage calculation that were developed for the Watts Bar FSAR (TVA 2004d). The original site analysis determined the elevation resulting from the site PMP would be less than the critical elevation of 729.0. This was based on a flow path from north to south along the east side the turbines and turbine building and through the switchyard. The new multipurpose building (28) and temporary craft trailers (29) are being designed not to exceed the footprint of the buildings that have been removed from this area (Richard King, TVA, personal communication, December 2006). Therefore, the new structures would not impact previously determined PMP elevations. The proposed new construction access facility (31) would be located adjacent to the existing control building and auxiliary (reactor) building and would not impact flood elevations. The temporary outage building (33) would not be an obstruction as shown on the current site plan.

Construction of the temporary parking areas (3) could result in minor changes to the existing topography, but PMP drainage from these areas does not flow toward the plant and, therefore, no adverse impacts would be expected. An area on the west side of the plant south of the Unit 2 material handling building that has in the past been used for temporary parking should be designated as a no parking area. This area is located within the PMP drainage “ditch” and any cars parked in the area could adversely impact PMP drainage elevations. Although there is no indication that development would take place in the switchyard area (30), this area has been identified as critical for PMP drainage. Therefore, any structural modifications that are proposed in the switchyard should be reviewed prior to construction to ensure they would not adversely impact PMP drainage elevations.

Based on the current design and site plan, the proposed project would be consistent with Executive Order 11988, and there would be no anticipated adverse flood-related impacts. Any changes to the tentative site plan would be reviewed to determine the potential for flood related impacts.

3.10. Seismic Effects

The 1972 FES described the maximum historical Modified Mercalli Intensity (a scale of earthquake effects that ranges from Roman numeral I through XII) experienced at WBN from local quakes and the origins of this ground motion. The 1995 FSER described the safe shutdown earthquake for WBN and its basis and discussed seismic analyses of WBN using a site-specific earthquake model and a review level earthquake (TVA 1995b). The WBN FSAR (TVA 2004d) provides a thorough description of the geology and seismicity in the vicinity of WBN in Section 2.5. The basic conclusions of the 1995 FSER and the 1972 FES with respect to the regional seismology of WBN and its seismic design remain valid. There are two items that require updating. First, the largest earthquake in the southern Appalachians since the 1972 FES is now the April 29, 2003, Fort Payne, Alabama, earthquake, which had a moment magnitude of 4.6 and Nuttli body wave magnitude of 4.9. The Fort Payne earthquake’s magnitude is still lower than the design basis earthquake, which has a body wave magnitude of 5.8; therefore, the occurrence of the 2003 Fort Payne earthquake has no significant impact on previous findings.

Second, preliminary results of the Individual Plant Examination for External Events (IPEEE) for WBN were discussed in the 1995 FSER. The final results of this study were completed and transmitted to NRC in February 1998 (TVA 1998e). The study included an examination of seismic effects and concluded that the seismic capacity of WBN for a Review Level Earthquake exceeds $0.3g^6$, the minimum level required by NRC. Therefore, no seismic design change recommendations resulted from the IPEEE seismic evaluation.

3.11. Climatology and Meteorology

The 1972 FES contains a discussion of the climatology and meteorology for the Watts Bar site. The 1995 FSER provides a description of the Watts Bar on-site meteorological program and a review of the previous discussion. The conclusion was that the regional climate description in the 1972 FES remained valid. Some of the information was updated based on more recent data. It also concluded that the 20-year data period update (1974-1993) in local meteorology was more representative than the one year of data used previously. The severe weather information in the 1972 FES was judged to be valid except for an update to the tornado data.

Regional Climatology

The regional climate description in the 1972 FES remains accurate as discussed in this section. This conclusion is based on information contained in the *Local Climatological Data Annual Summary Comparative Data for Chattanooga, Tennessee, for 2005* (U.S. Department of Commerce 2005) and in the *Climatography of the United States No. 81* (U.S. Department of Commerce 2003).

Temperature data for the 1971-2000 period of record for Chattanooga, Tennessee, indicate an average annual temperature of 60.0°F , with monthly averages ranging from 39.4°F in January to 79.6°F in July. These temperatures are slightly warmer than data for the 1961-1990 period of record used in the 1995 FSER. The extreme temperatures, maximum rainfall in 24 hours, and maximum snowfall in 24 hours at Chattanooga are the same for the 1971-2000 period as for the 1961-1990 period. Wind speed data from Chattanooga for the 1971-2000 period of record indicate an average wind speed of 5.9 miles per hour. This is slightly lower than data for the 1961-1990 period of record.

Local Meteorology

The one year of data collected from the temporary WBN meteorological facility is supplemented with more representative data from the 20-year period from 1986-2005. These data were collected from the permanent meteorological facility. On an annual basis, the most frequent wind directions at 10 meters are south-southwest and southwest at 16.0 percent and 8.4 percent, respectively. This reflects a small shift from easterly to westerly directions from the on-site data from 1974-1993 used in the 1995 FSER. The annual average wind speed decreased from 4.1 miles per hour to 3.7 miles per hour at the 10-meter level in the more recent 20-year data period. In addition, the annual frequency of calms, defined as wind speeds less than 0.6 mi/h, increased from 3.0 percent to 3.4 percent. The impact of these changes on dispersion values is discussed below under the heading dispersion.

⁶ Percent "g" is the force of gravity (an acceleration of $9.78 \text{ meters/second}^2$). When there is an earthquake, the forces caused by the shaking can be measured as a percentage of the force of gravity, or percent g.

Severe Weather

Based on Section 2.3.1.3 of the WBN FSAR (TVA 2004d), the severe weather information in the 1972 FES remains accurate, except for the following update. During the period from 1916-2005, only one tornado has been reported in Rhea County. The FSAR estimate of the probability of a tornado striking the site is $1.48E-4$ with a recurrence interval of 6755 years. This is based on tornado data from 1950 through 1986. Extension of the tornado database end date from 1986 to 2005 increases the estimate of the probability of a tornado striking the site to $2.7 E-4$ with a recurrence interval of 3703 years. During the period from 1950-2005, 44 tornadoes were identified within a 30-nautical-mile radius of Watts Bar (approximately 2827 square miles). The mean tornado path was 0.96 square miles, and the annual tornado frequency was 0.80.

Dispersion

Section 5.10 of the 1995 FESER presents the estimated annual airborne doses as calculated by the *Watts Bar Off-Site Dose Calculation Manual* (TVA 1994b). It uses the 20-year period of meteorological data from 1974-1993. Use of the later 20-year data period discussed in under local meteorology, above, results in an increase of the maximum dispersion value from $1.09E-5$ to $1.43E-5$ second/cubic meters and shifts the critical downwind sector from southeast to east-southeast. The impact of this increase is discussed in Section 3.13.

Air Quality

Two oil-fired boilers used for building heat and startup steam emit small amounts of air pollutants as addressed in the 1972 FES. These emissions are controlled to meet applicable regulatory requirements, and resulting impacts are insignificant.

3.12. Nuclear Plant Safety and Security

3.12.1. Severe Accident Analysis

TVA maintains a probabilistic safety assessment model to use in evaluating the most significant risks of radiological release from WBN fuel into the reactor and from the reactor into the containment structure. In 1995, both TVA and NRC concluded that, except for a few procedural changes implemented as part of the WBN operation, none of the severe accident mitigation design alternatives were beneficial to mitigating the risk of severe accidents further. The term "accident" refers to any unintentional event (i.e., outside the normal or expected plant operation envelope) that results in a release or a potential for a release of radioactive material to the environment. The NRC categorizes accidents as either design basis or severe. Design basis accidents are those for which the risk is great enough that NRC requires plant design and construction to prevent unacceptable accident consequences. Severe accidents are those that NRC considers too unlikely to warrant normal design controls.

Since 1995, TVA has implemented the industry-required design and corresponding design and corresponding mitigating action changes as required by NRC for continued operation of WBN Unit 1 and would implement them for operation of Unit 2. The design changes have already been implemented in the WBN Unit 1 probabilistic safety assessment model. The analysis is based on the WBN Unit 1 probabilistic safety assessment model, which is considered applicable for Unit 2 operations because of its similarity to Unit 1.

An analysis was performed for this FSEIS to estimate the human health impacts from potential accidents at WBN in the event that Unit 2 became operational (Karimi 2007). Only severe reactor accident scenarios leading to core damage and containment bypass or containment failure are presented here. Accident scenarios that do not lead to containment bypass or containment failure are not presented because the public and environmental consequences would be significantly less.

The MACCS2 computer code (Version 1.13.1) was used to perform probabilistic analyses of radiological impacts. The generic input parameters given with the MACCS2 computer code that were used in NRC's severe accident analysis (NUREG-1150) formed the basis for the analysis. These generic data values were supplemented with parameters specific to WBN and the surrounding area. Site-specific data included population distribution, economic parameters, and agricultural product. Plant-specific release data included nuclide release, release duration, release energy (thermal content), release frequency, and release category (i.e., early release, late release). The behavior of the population during a release (evacuation parameters) was based on declaration of a general emergency and the emergency planning zone (EPZ) evacuation time. These data in combination with site-specific meteorology were used to simulate the probability distribution of impact risks (exposure and fatalities) to the surrounding 80-kilometer (within 50 miles) population.

The consequences of a beyond-design-basis accident, with mean meteorological conditions, to the maximally exposed off-site individual, an average individual, and the population residing within an 80-kilometer (50-mile) radius of the reactor site are summarized in Table 3-13. The analysis assumed that a site emergency would have been declared early in the accident sequence and that all nonessential site personnel would have evacuated the site in accordance with site emergency procedures before any radiological releases to the environment occurred. In addition, emergency action guidelines would have been implemented to initiate evacuation of 99.5 percent of the public within 16 kilometers (10 miles) of the plant. The location of the maximally exposed off-site individual may or may not be at the site boundary for these accident sequences because emergency action guidelines would have been implemented and the population would be evacuating from the path of the radiological plume released by the accident.

Table 3-13. Severe Accident Annual Risks

Release Category (frequency per reactor year)	Maximally Exposed Off-Site Individual		Average Individual Member of Population Within 80 Kilometers (50 miles)	
	Dose Risk ^a (rem/year)	Cancer Fatality ^b	Dose Risk ^a (rem/year)	Cancer Fatality ^b
I - Early Containment failure (3.4×10^{-7})	2.2×10^{-5}	2.6×10^{-8}	1.8×10^{-7}	1.1×10^{-10}
II - Containment Bypass (1.4×10^{-6})	2.2×10^{-5}	1.3×10^{-8}	8.2×10^{-7}	4.9×10^{-10}
III - Late Containment Failure (3.0×10^{-6})	4.6×10^{-7}	2.8×10^{-10}	1.3×10^{-7}	7.8×10^{-11}

^a Includes the likelihood of occurrence of each release category

^b Increased likelihood of cancer fatality per year

The results presented in this table indicate that the highest risk to the maximally exposed off-site individual is one fatality every 38 million years (or 2.6×10^{-8} per year) and the

highest risk to an average individual member of the public is one fatality every 2 billion years (or 4.9×10^{-10} per year). Overall, the risk results presented above are small. Completion and operation of WBN Unit 2 would not change the risks evaluated here because the likelihood of an accident that could affect both units and lead to radioactive releases beyond those analyzed here would be extremely low. This is consistent with the conclusions of NRC's Generic Environmental Impact Statement for License Renewal of Nuclear Plants (GEIS) (NRC 1996a). Accidents that could affect multi-unit sites are initiated by external events. Severe accidents initiated by external events as tornadoes, floods, earthquakes, and fires traditionally have not been discussed in quantitative terms in final environmental statements and were not considered in the GEIS. In the GEIS, however, NRC staff did evaluate existing impact assessments performed by NRC and the industry at 44 nuclear plants in the United States and concluded that the risk from beyond-design-basis earthquakes at existing nuclear power plants is small. Additionally, the staff concluded that the risks from other external events are adequately addressed by a generic consideration of internally initiated severe accidents.

3.12.2. Terrorism

Some nongovernmental entities and members of the public have expressed concern about the risks posed by nuclear generating facilities in light of the threat of terrorism. Because WBN is already an active nuclear generating facility, the risks posed by adding a second generating unit are not the same as the risks that may be associated with locating a nuclear generating facility at a new location. The risk posed by a terrorist attack already exists at this site. Regardless, TVA believes that the possibility of a terrorist attack affecting operation of WBN Unit 2 or the combined operation of both WBN units is very remote and that postulating potential health and environmental impacts from a terrorist attack involves substantial speculation.

TVA has in place detailed, sophisticated security measures to prevent physical intrusion into its nuclear plant sites, including WBN, by hostile forces seeking to gain access to plant nuclear reactors or other sensitive facilities or materials. TVA contract security personnel are trained and retrained to react to and repel hostile forces threatening TVA nuclear facilities. TVA's security measures and personnel are inspected and tested by the NRC. It is highly unlikely that a hostile force could successfully overcome these security measures and gain entry into sensitive facilities, and even less likely that they could do this quickly enough to prevent operators from putting plant reactors into safe shutdown mode. However, the security threat that is more frequently identified by members of the public or in the media are not hostile forces invading nuclear plant sites but attacks using hijacked jet airliners, the method used on September 11, 2001, against the World Trade Center and the Pentagon. The likelihood of this now occurring is equally remote in light of today's heightened security awareness, but this threat has been carefully studied.

The Nuclear Energy Institute (NEI) commissioned the Electric Power Research Institute (EPRI) to conduct an impact analysis of a large jet airline being purposefully crashed into sensitive nuclear facilities or containers including nuclear reactor containment buildings, used fuel storage ponds, used fuel dry storage facilities, and used fuel transportation containers. The EPRI analysis was peer reviewed when it was finished. Using conservative analyses, EPRI concluded that there would be no release of radionuclides from any of these facilities or containers. They are already designed to withstand potentially destructive events. Nuclear reactor containment buildings, for example, have thick concrete walls with heavy reinforcing steel and are designed to withstand large

earthquakes, extreme overpressures, and hurricane force winds. Using computer models, a Boeing 767-400 was crashed into containment structures that were representative of all U.S. nuclear power containment types. The containment structures suffered some crushing and chipping at the maximum impact point but were not breached. The results of this analysis are summarized in an NEI paper titled "Aircraft Crash Impact Analyses Demonstrate Nuclear Power Plant's Structural Strength" (NEI 2002). (For security reasons, the EPRI analysis has not been publicly released.)

The EPRI analysis is fully consistent with research conducted by NRC. When NRC recently considered such threats, NRC Commissioner McGaffigan observed:

Today the NRC has in place measures to prevent public health and safety impacts of a terrorist attack using aircraft that go beyond any other area of our critical infrastructure. In addition to all the measures the Department of Homeland Security and other agencies have put in place to make such attacks extremely improbable (air marshals, hardened cockpit doors, passenger searches, etc.), NRC has entered into a Memorandum of Understanding with NORAD/NORTHCOM to provide real-time information to potentially impacted sites by any aircraft diversion.

As NRC has said repeatedly, our research showed that in most (the vast majority of) cases an aircraft attack would not result in anything more than a very expensive industrial accident in which no radiation release would occur. In those few cases where a radiation release might occur, there would be no challenge to the emergency planning basis currently in effect to deal with all beyond-design-basis events, whether generated by mother nature, or equipment failure, or terrorists (NRC 2007).

Notwithstanding the very remote risk of a terrorist attack affecting WBN operations, TVA increased the level of security readiness, improved physical security measures, and increased its security arrangements with local and federal law enforcement agencies at all of its nuclear generating facilities after the events of September 11, 2001. These additional security measures were taken in response to advisories issued by NRC. TVA continues to enhance security at its plants in response to NRC guidance. The security measures TVA has taken at WBN are complemented by the measures taken throughout the United States to improve security and reduce the risk of successful terrorist attacks. This includes measures designed to respond to and reduce the threats posed by hijacking large jet airliners.

In the very remote likelihood that a terrorist attack did successfully breach the physical and other safeguards at WBN resulting in the release of radionuclides, the consequences of such a release are reasonably captured by the discussion of the impacts of severe accidents discussed above in this section.

3.13. Radiological Effects

This section discusses the potential expected radiological dose exposure of the public during normal operations of WBN Units 1 and 2. Based on operational data from WBN Unit 1, TVA expects WBN Unit 2 dose data to be of the same magnitude as those projected in its 1972 FES for a single unit. TVA has determined that the doses to the public resulting from the discharge of radioactive effluents from WBN would likely be less than two percent of the NRC guidelines given in 10 CFR 50 Appendix I, and that there would be no new or

different effects on the surrounding environment due to these releases than from those discussed in the FES. NRC addressed potential radiological effects in detail in its SEIS, at pp. 5-11 to 5-21 (NRC 1995b). TVA's assessment of potential impact agrees with NRCs. The dose values used in the Draft SEIS assessment were based on calculations that used meteorological data from January 1974 to December 1993. TVA has recalculated the dose values using meteorological data from January 1986 to December 2005 for the FSEIS. The revised values do not differ materially from those presented in the DSEIS.

Radiological Impacts on Humans

Radionuclides in Liquid Effluents

The exposure pathways to humans that were used in the 1972 FES analysis remain valid. The pathways considered are illustrated in Figure 3-6. Several of the pathways included in the 1972 FES analysis are not considered in the current analysis of the impact of the release of radioactivity in liquid effluents in the area around WBN site. These pathways are doses received from swimming in and boating on the Tennessee River. These pathways are no longer considered because they have been found to be several orders of magnitude lower than the dose received from shoreline recreation. The exclusion of these external dose pathways for the analysis does not significantly change the calculated dose commitments to individuals or populations since essentially all of the total body dose due to the release of radioactive material is accounted for by fish and water ingestion. Doses to terrestrial vertebrates from the consumption of aquatic plants, and doses to aquatic plants, aquatic invertebrates, and fish have not been reassessed in the current analysis of the impact of radioactivity in liquid effluents because doses to these organisms are less than or equal to the doses to humans (TVA 1972).

Current analyses of potential doses to members of the public due to releases of radioactivity in liquid effluents are calculated using the models presented in NUREG-0133 (NRC 1996b) and *Regulatory Guide 1.109, Revision 1* (NRC 1977). These models are essentially those used in the 1972 FES, and are based on the *International Commission of Radiological Protection Publication 2*. Changes in the model assumptions since the release of the 1972 FES include:

The calculation of doses to additional organs (kidney and lung).

River water use (ingestion, fish harvest), and recreational use data have been updated using more recent information (Tables 3-14 and 3-15).

Decay time between the source and consumption is handled as describe in *Regulatory Guide 1.109* (NRC 1977).

Only those doses within a 50-mile radius of WBN are considered in the population dose.

The population data are updated and projected through the year 2040.

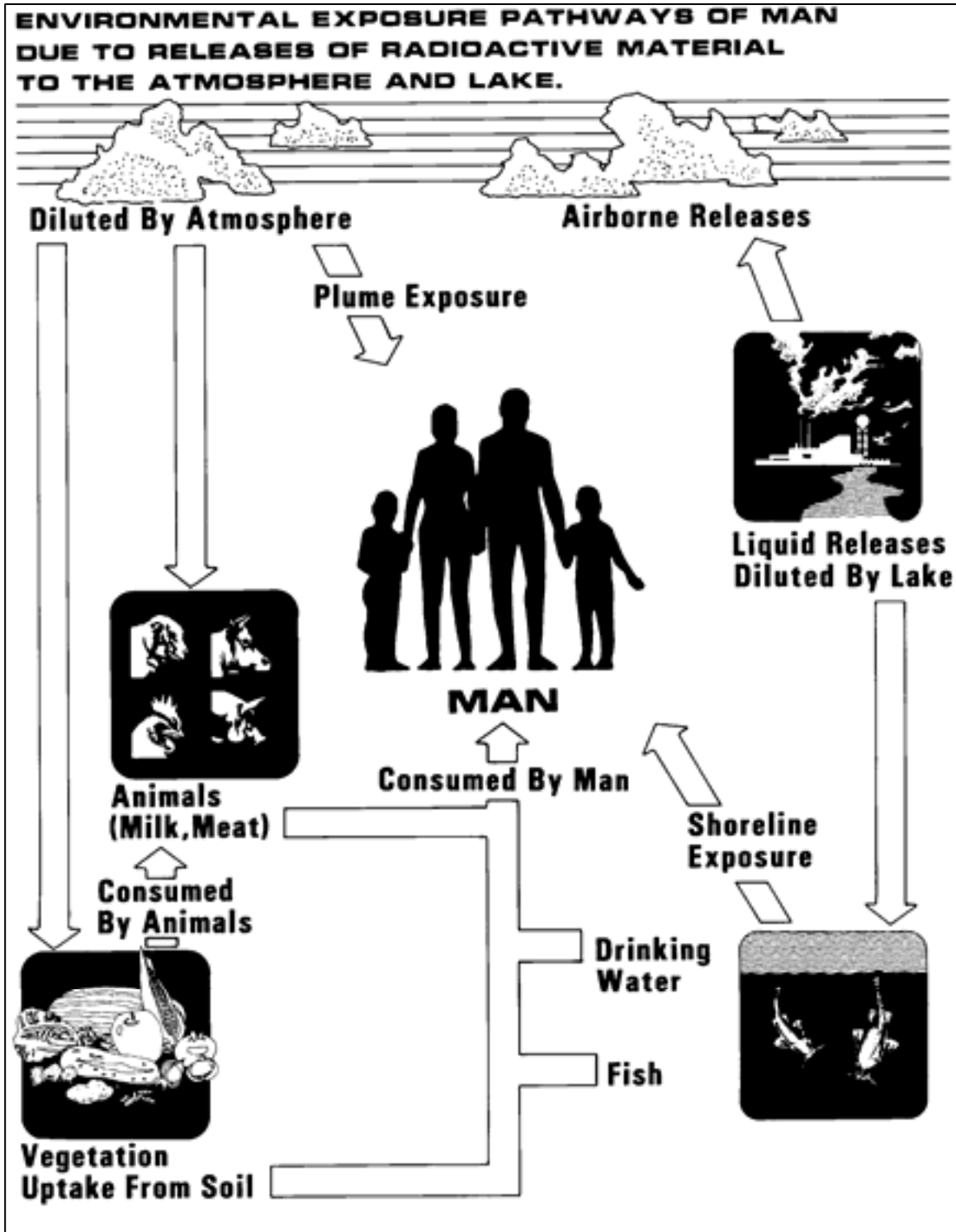

Figure 3-6. Pathways to Man Due to Releases of Radioactive Material

Table 3-14. Public Water Supplies Within a 50-Mile Radius Downstream of WBN

Name	Tennessee River Mile	Estimated 2040 Population
Dayton, Tennessee	504	19,170
Soddy-Daisy/Falling Water Utility District	487	11,452
East Side Utility, Tennessee	473	49,700
Chattanooga, Tennessee	465	237,048

Table 3-15. Estimated Recreational Use of Tennessee River Within a 50-Mile Radius Downstream of WBN

Name	Beginning TRM ¹	Ending TRM	Size (acres)	Estimated 2040 Recreational visits/year
Chickamauga Reservoir (from WBN to 100 percent mixing point)	528	510	4,799	120,986
Chickamauga Reservoir (from 100 percent mixing point to SQN)	510	484	22,101	1,297,880
Chickamauga Reservoir (from SQN to Chickamauga Dam)	484	471	9,889	7,421,905
Nickajack Reservoir (from Chickamauga Dam to WBN 50-mile radius)	471	460	1,799	284,000

¹Tennessee River Mile

Transfer coefficients, consumption rates, and bioaccumulation factors used are those presented in the documents listed above, or more recent data, if available. The models and input variable used are those presented in the *Watts Bar Off-Site Dose Calculation Manual* (TVA 1994b), which was approved by the NRC on July 26, 1994. The estimated liquid radioactive releases used in the analysis are given in Table 3-16.

Table 3-16. WBN Total Annual Discharge-Liquid Waste Processing System for Two-Unit Operation

Nuclide	1 Unit LRW ¹	1 Unit SGB ²	1 Unit Totals	2 Unit Totals
Br-84	1.65E-04	5.23E-04	6.88E-04	1.38E-03
I-131	2.63E-02	1.14E+00	1.16E+00	2.33E+00
I-132	1.32E-02	1.08E-01	1.21E-01	2.43E-01
I-133	5.29E-02	8.57E-01	9.10E-01	1.82E+00
I-134	6.26E-03	2.65E-02	3.28E-02	6.55E-02
I-135	4.75E-02	4.22E-01	4.70E-01	9.39E-01
Rb-88	6.89E-03	7.84E-04	7.68E-03	1.54E-02
Cs-134	2.93E-02	1.68E-01	1.98E-01	3.95E-01
Cs-136	2.55E-03	1.72E-02	1.98E-02	3.96E-02
Cs-137	4.03E-02	2.21E-01	2.61E-01	5.23E-01
Na-24	1.86E-02	0.0E+00	1.86E-02	3.72E-02
Cr-51	7.03E-03	9.27E-02	9.98E-02	2.00E-01
Mn-54	4.99E-03	5.10E-02	5.59E-02	1.12E-01
Fe-55	8.09E-03	0.0E+00	8.09E-03	1.62E-02
Fe-59	2.42E-03	9.05E-03	1.15E-02	2.29E-02
Co-58	2.20E-02	1.44E-01	1.66E-01	3.31E-01
Co-60	1.44E-02	1.72E-02	3.16E-02	6.32E-02
Zn-65	3.82E-04	0.0E+00	3.82E-04	7.65E-04
Sr-89	1.92E-04	4.33E-03	4.52E-03	9.03E-03
Sr-90	2.20E-05	3.88E-04	4.10E-04	8.19E-04
Sr-91	2.84E-04	2.18E-03	2.47E-03	4.94E-03
Y-91m	1.68E-04	0.0E+00	1.68E-04	3.37E-04
Y-91	9.00E-05	3.00E-04	3.90E-04	7.80E-04
Y-93	1.27E-03	0.0E+00	1.27E-03	2.54E-03
Zr-95	1.39E-03	1.20E-02	1.34E-02	2.68E-02
Nb-95	2.10E-03	8.98E-03	1.11E-02	2.22E-02
Mo-99	4.20E-03	9.95E-02	1.04E-01	2.07E-01
Tc-99m	3.35E-03	0.0E+00	3.35E-03	6.70E-03
Ru-103	5.88E-03	0.0E+00	5.88E-03	1.18E-02
Ru-106	7.63E-02	0.0E+00	7.63E-02	1.53E-01
Te-129m	1.41E-04	0.0E+00	1.41E-04	2.82E-04
Te-129	7.30E-04	0.0E+00	7.30E-04	1.46E-03
Te-131m	8.05E-04	0.0E+00	8.05E-04	1.61E-03
Te-131	2.03E-04	0.0E+00	2.03E-04	4.06E-04
Te-132	1.11E-03	2.93E-02	3.05E-02	6.09E-02
Ba-140	1.02E-02	3.48E-01	3.58E-01	7.16E-01
La-140	1.62E-02	4.98E-01	5.14E-01	1.03E+00
Ce-141	3.41E-04	0.0E+00	3.41E-04	6.81E-04
Ce-143	1.53E-03	0.0E+00	1.53E-03	3.05E-03

Table 3-16 (continued)

Nuclide	1 Unit LRW ¹	1 Unit SGB ²	1 Unit Totals	2 Unit Totals
Ce-144	6.84E-03	1.26E-01	1.33E-01	2.66E-01
Np-239	1.37E-03	0.0E+00	1.37E-03	2.75E-03
H-3	1.25E+03	0.0E+00	1.25E+03	2.51E+03
H-3 (TPC)	3.33E+03	0.0E+00	3.33E+03	4.58E+03
Totals w/o H-3	4.38E-01		4.84E+00	9.68E+00
Totals w H-3	1.25E+03		1.26E+03	2.52E+03
Total w H-3 (TPC³)	3.33E+03		3.33E+03	4.59E+03

¹ Liquid Radwaste

² Steam Generator Blowdown

³ Tritium Production Core (single unit)

A companion figure, illustrating the release points for radioactive plant liquid effluents from WBN is presented in Figure 3-7. A simplified diagram of the WBN radioactive liquid waste (radwaste) system is shown in Figure 3-8. The liquid radwaste system is designed to control and minimize release of the subject radionuclides.

A tabulation of the resulting calculated doses for Unit 2 without TPC is given in Table 3-17. Doses for adults, teens, children, and infants are in millirem (mrem). Population doses are in man-rem.

The estimated annual liquid releases and resulting doses as presented by the TVA 1972 FES, the WBN Unit 1 FSAR, Unit 2, Unit 1 and 2 totals, and recent historical data from WBN Unit 1 (as submitted in the Annual Radioactive Effluent Reports to the NRC) with the guidelines given by NRC in 10 CFR 50, Appendix I are compared in Table 3-18. These guidelines are designed to assure that releases of radioactive material from nuclear power reactors to unrestricted areas during normal conditions, including expected occurrences, are kept as low as practicable.

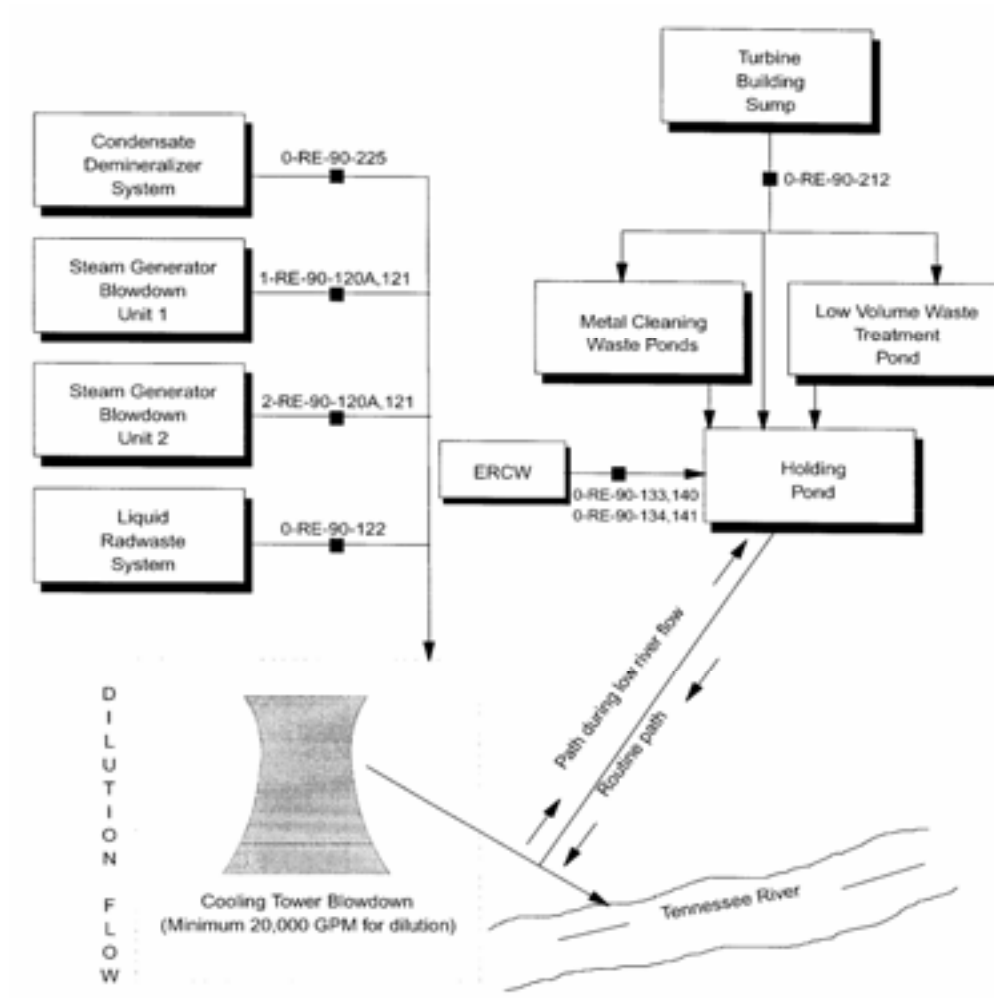

GPM = Gallons per Minute

Figure 3-7. Plant Liquid Effluent Pathways and Release Points

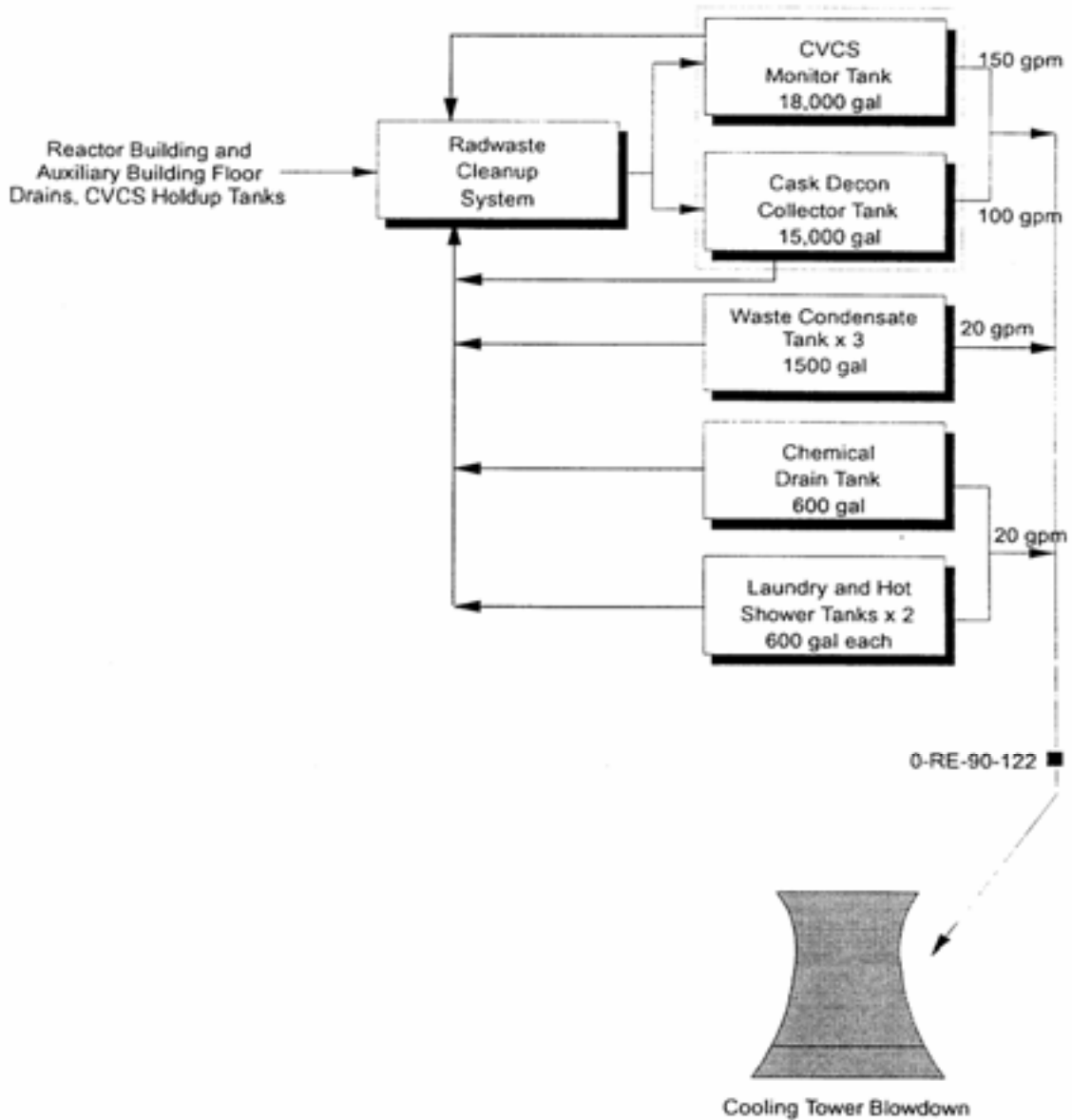

Figure 3-8. Watts Bar Nuclear Plant Liquid Radwaste System

Table 3-17. Watts Bar Nuclear Plant Doses From Liquid Effluents per Unit for Year 2040

(mrem)								
ADULT	TB ¹	Bone	GIT ²	Thyroid	Liver	Kidney	Lung	Skin
	0.72	0.56	0.132	0.88	0.96	0.352	0.136	0.031
TEEN	TB	Bone	GIT	Thyroid	Liver	Kidney	Lung	Skin
	0.44	0.6	0.104	0.8	1	0.356	0.152	0.031
CHILD	TB	Bone	GIT	Thyroid	Liver	Kidney	Lung	Skin
	0.188	0.76	0.06	0.92	0.88	0.312	0.128	0.031
INFANT	TB	Bone	GIT	Thyroid	Liver	Kidney	Lung	Skin
	0.032	0.036	0.033	0.264	0.036	0.034	0.032	0.031
(man-rem)								
POP³ DOSE	TB	Bone	GIT	Thyroid	Liver	Kidney	Lung	Skin
	1.14	1.24	1	10.8	1.5	0.98	0.73	0.222
POP DOSE 2040	TB	Bone	GIT	Thyroid	Liver	Kidney	Lung	Skin
	1.619	1.761	1.420	15.336	2.130	1.392	1.037	0.315

¹Total body

²Gastro intestinal tract

³Population

Table 3-18. Comparison of Estimated Annual Liquid Releases and Resulting Doses per Unit at WBN

	1972 FES (Table 2.4-2)	Unit 1 FSAR	Unit 2 Evaluation	Units 1 & 2 Combined	Unit 1 10 year Operational Average	10 CFR 50 Appendix I Guidelines per Unit
Tritium Released (Ci)¹	1.46E+02	3.33E+03	1.25E+03	4.58E+03	707	N/A ²
Activity Released (Ci)¹	3.2E-01	4.84	4.84	9.68	2.2E-01	10
Total Body Dose (mrem)³	1.7E-02	7.2E-01	7.2E-01	1.44E+00	3.1E-02	3
Maximum Organ Dose (mrem)³	5.5E-02	1.0 E+00	1.0E+00	2.0E+00	4.25E-02	10

¹ Ci = Curies

² N/A = Not Applicable

³ mrem = millirem

Several conclusions can be drawn from the data in Table 3-18:

- The Unit 2 estimates, even though based on very conservative (worst-case) assumptions, indicate that estimated doses would continue to meet the per unit dose guideline given in 10 CFR Part 50, Appendix I.
- Recent WBN operational data for liquid effluents indicated that actual releases and resulting dose estimates to the public are a small fraction of the Appendix I guidelines (averaging about two percent or less). Based on these conclusions, the analyses of radiological impact to humans from liquid releases in the TVA FES continue to be valid, and operation of WBN Unit 2 would not materially change the result.

Radionuclides in Gaseous Effluents

The exposure pathways used in the current analyses of the impact of radioactive material released in gaseous effluents are expanded from those used in the 1972 FES. The pathways considered are illustrated in Figure 3-6. These pathways include external doses due to noble gases, and internal doses from particulates due to inhalation, and the ingestion of milk, meat, and vegetables from the area around WBN. Changes in the model assumptions since the publication of the TVA FES include: the calculation of internal doses to additional organs (bone, liver, total body, gastrointestinal tract, kidney, and lung); actual land use survey results are used (shown in Table 3-19); and the population data are projected through the year 2040. Current analyses of potential doses to members of the public due to releases of radioactivity in gaseous effluents are calculated using the models presented in NUREG-0133 (NRC 1996b) and *Regulatory Guide 1.109, Revision 1* (NRC 1977). These models are those used in the TVA FES, and are based on the *International Commission of Radiological Protection Publication 2*. Transfer coefficients, consumption rates, and bioaccumulation factors used are those presented in the documents listed above, or more recent data, if available. The models and input variable used are those presented in the *WBN Off-Site Dose Calculation Manual*, which was approved by the NRC on July 26, 1994. The estimated gaseous radioactive releases used in the analysis are given in Table 3-20.

Table 3-19. Receptors from Actual Land Use Survey Results Used for Potential Gaseous Releases From WBN Unit 2

Receptor Number	Receptor Type	Sector	Distance (meters)
1	Nearest Residence	N	2134
2	Nearest Residence	NNE	3600
3	Nearest Residence	NE	3353
4	Nearest Residence	ENE	2414
5	Nearest Residence	E	3139
6	Nearest Residence	ESE	4416
7	Nearest Residence	SE	1372
8	Nearest Residence	SSE	1524
9	Nearest Residence	S	1585
10	Nearest Residence	SSW	1979
11	Nearest Residence	SW	4230
12	Nearest Residence	WSW	1829
13	Nearest Residence	W	2896
14	Nearest Residence	WNW	1646
15	Nearest Residence	NW	3048
16	Nearest Residence	NNW	4389
17	Nearest Garden	N	7644
18	Nearest Garden	NNE	6173
19	Nearest Garden	NE	3829
20	Nearest Garden	ENE	4831
21	Nearest Garden	E	8005
22	Nearest Garden	ESE	4758
23	Nearest Garden	SE	4633
24	Nearest Garden	SSE	2043
25	Nearest Garden	S	4973
26	Nearest Garden	SSW	2286
27	Nearest Garden	SW	8100
28	Nearest Garden	WSW	4667
29	Nearest Garden	W	5150
30	Nearest Garden	WNW	5793
31	Nearest Garden	NW	3170
32	Nearest Garden	NNW	4698
33	Milk Cow	ESE	6096
34	Milk Cow	ESE	6706
35	Milk Cow	SSW	2286
36	Milk Cow	SSW	3353
37	Milk Cow	NW	8100

Table 3-20. WBN Total Annual Gaseous Discharge Per Operating Unit (curies/year/reactor)

Nuclide	Containment Building	Auxiliary Building	Turbine Building	Total per Unit
Kr-85m	1.99E+01	4.53E+00	1.23E+00	2.57E+01
Kr-85	6.90E+02	7.05E+00	1.86E+00	6.99E+02
Kr-87	1.09E+01	4.27E+00	1.09E+00	1.63E+01
Kr-88	2.83E+01	7.95E+00	2.13E+00	3.84E+01
Xe-131m	1.17E+03	1.73E+01	4.53E+00	1.19E+03
Xe-133m	4.63E+01	1.90E+00	5.21E-01	4.87E+01
Xe-133	3.12E+03	6.70E+01	1.77E+01	3.20E+03
Xe-135m	3.85E+00	3.68E+00	9.80E-01	8.51E+00
xXe-135	1.55E+02	2.40E+01	6.46E+00	1.85E+02
Xe-137	3.18E-01	9.67E-01	2.58E-01	1.54E+00
Xe-138	3.32E+00	3.42E+00	9.06E-01	7.65E+00
Ar-41	3.40E+01	0.00E+00	0.00E+00	3.40E+01
Br-84	6.00E-05	5.01E-02	4.81E-04	5.06E-02
I-131	7.29E-03	1.39E-01	7.08E-03	1.53E-01
I-132	1.60E-03	6.56E-01	1.70E-02	6.75E-01
I-133	3.55E-03	4.35E-01	2.03E-02	4.59E-01
I-134	1.66E-03	1.06E+00	1.47E-02	1.08E+00
I-135	3.16E-03	8.10E-01	3.13E-02	8.44E-01
H-3	1.37E+02	0.00E+00	0.00E+00	1.37E+02
H-3 (TPC)	3.70E+02	0.00E+00	0.00E+00	3.70E+02
Cr-51	9.21E-05	5.00E-04	0.00E+00	5.92E-04
Mn-54	5.30E-05	3.78E-04	0.00E+00	4.31E-04
Co-57	8.20E-06	0.00E+00	0.00E+00	8.20E-06
Co-58	2.50E-04	2.29E-02	0.00E+00	2.32E-02
Co-60	2.61E-05	8.71E-03	0.00E+00	8.74E-03
Fe-59	2.70E-05	5.00E-05	0.00E+00	7.70E-05
Sr-89	1.30E-04	2.85E-03	0.00E+00	2.98E-03
Sr-90	5.22E-05	1.09E-03	0.00E+00	1.14E-03
Zr-95	4.80E-08	1.00E-03	0.00E+00	1.00E-03
Nb-95	1.80E-05	2.43E-03	0.00E+00	2.45E-03
Ru103	1.60E-05	6.10E-05	0.00E+00	7.70E-05
Ru-106	2.70E-08	7.50E-05	0.00E+00	7.50E-05
Sb-125	0.00E+00	6.09E-05	0.00E+00	6.09E-05
Cs-134	2.53E-05	2.24E-03	0.00E+00	2.27E-03
Cs-136	3.21E-05	4.80E-05	0.00E+00	8.01E-05
Cs-137	5.58E-05	3.42E-03	0.00E+00	3.48E-03
Ba-140	2.30E-07	4.00E-04	0.00E+00	4.00E-04
Ce-141	1.30E-05	2.64E-05	0.00E+00	3.94E-05
C-14	2.80E+00	4.50E+00	0.00E+00	7.30E+00

A companion figure, illustrating the release points for radioactive gaseous effluents from WBN is presented in Figure 3-9.

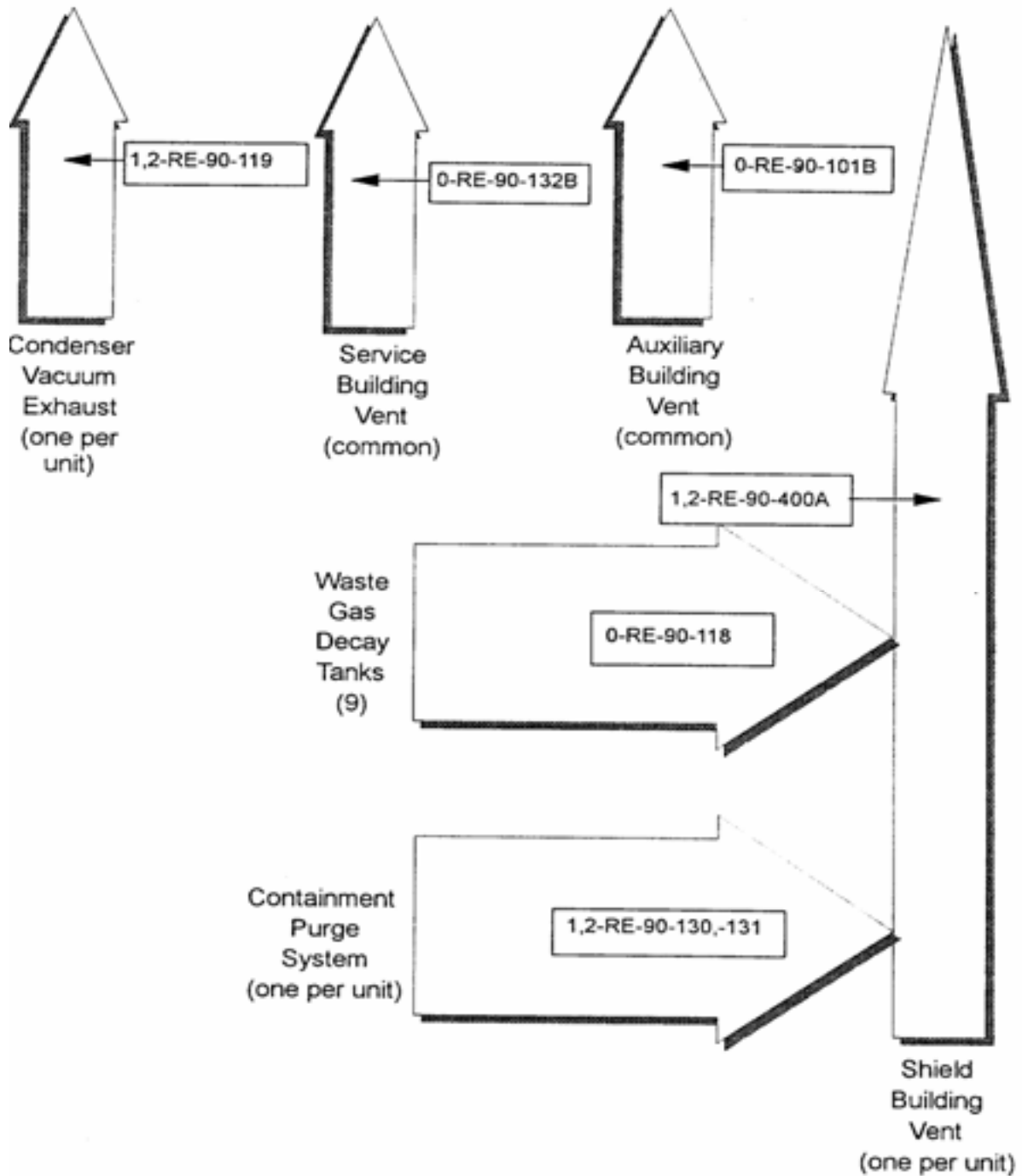

Figure 3-9. Watts Bar Nuclear Plant Gaseous Effluent Release Points

A tabulation of the resulting calculated gaseous doses to individuals per operational unit is given in Table 3-21.

Table 3-21. WBN Doses From Gaseous Effluent For Unit 2 Without Tritium Production for Year 2040

Effluent	Pathway	Guideline ¹	Location	Dose
Noble Gases	γ Air dose	10 mrad	Maximum Exposed Individual ²	0.801 mrad/year
	β Air dose	20 mrad	Maximum Exposed Individual ²	2.710 mrad/year
	Total body	5 mrem	Maximum Residence ^{3,4}	0.571 mrem/year
Iodines/ Particulate	Skin	10 mrem	Maximum Residence ^{3,4}	1.540 mrem/year
	Thyroid (critical organ)	15 mrem	Maximum Real Pathway ⁵	2.715 mrem/year

Breakdown of Iodine/Particulate Doses (mrem/yr)

Cow Milk with Feeding Factor of 0.65	2.44
Inhalation	0.174
Ground Contamination	0.0405
Submersion	0.0603
Beef Ingestion ²	0.00
Total	2.7148

¹Guidelines are defined in Appendix I to 10 CFR Part 50.

²Maximum exposure point is at 1250 meters in the ESE sector.

³Dose from air submersion.

⁴Maximum exposed residence is at 1372 meters in the SE sector.

⁵Maximum exposed individual is an infant at 3353 meters in the SSW sector.

The estimated annual airborne releases and resulting doses as presented by the 1972 FES, the WBN Unit 1 FSAR, Unit 2, Unit 1 and 2 totals, and recent historical data from WBN Unit 1 (as submitted in the Annual Radioactive Effluent Reports to the NRC) with NRC guidelines given in 10 CFR 50 Appendix I are compared in Table 3-22. These guidelines are designed to assure that releases of radioactive material from nuclear power reactors to unrestricted areas during normal conditions, including expected occurrences, are kept as low as practicable.

Table 3-22. Comparison of Estimated Annual Airborne Releases and Resulting Doses

	1972 FES (Table 2.4-2)	Unit 1 FSAR	Unit 2 Evaluation	Units 1 & 2 Combined	Unit 1 10-year Operational Average	10 CFR 50 Appendix I Guidelines per Unit
Particulate Activity (Ci ¹)	3.0E-01	7.6E+00	4.70E-02	7.6E+00	9.29E-05	10
Noble Gas Activity (Ci ¹)	7.0E+03	1.4E+04	4.84E+03	4.84E+03	2.7E-03	N/A ²
External Dose (mrad ³)	6.6E+00	6.2E+00	3.5E+00	9.7E+00	3.69E-01	10
Organ Dose (mrem ⁴)	3.5E+00 (inhalation and milk only)	1.1E+01 (all pathways)	2.82E+00 (all pathways)	1.38E+01 (all pathways)	8.3E-02 (all pathways)	15

¹ Ci = Curies

² N/A = Not Applicable

³ mrad = millirad

⁴ mrem = millirem

Two conclusions can be drawn from the data in Table 3-20:

- The Unit 2 FSAR estimates, even though based on very conservative (worst-case) assumptions, indicate that estimated doses continue to meet the per unit dose guidelines given in 10 CFR Part 50, Appendix I.
- Historical WBN operational data for airborne effluents indicate that actual releases and resulting dose estimates (external and organ) to the public are a small fraction of the Appendix I guideline (averaging about 1 percent or less).

Based on these conclusions, the analyses of radiological impact from airborne release in the 1972 FES continue to be valid, and operation of WBN Unit 2 would not materially change the results.

Population Doses

TVA has estimated the radiological impact from the normal operation of WBN Unit 2 using a 50-mile regional population projection for the year 2040 of 1,523,385. The estimated population doses as presented by the 1972 FES, the WBN Unit 1 FSAR, Unit 2, Unit 1 and Unit 2 totals, and recent historical data from WBN (as submitted in the Annual Radioactive Effluent Reports to the NRC) are presented in Table 3-23.

Table 3-23. Estimated Population Doses From Operation of Watts Bar Nuclear Plant

1972 FES (Table 2.4-4)	Unit 1 FSAR	Unit 2 Evaluation	Units 1 & 2 Combined	Unit 1 10-year Operational Average	10 CFR 50 Appendix I Guidelines
3.1E+01	12.8E+00	2.362E+01	3.64E+01	3.38E-01	N/A

Releases to Sanitary Sewers

Releases to sanitary sewage systems from WBN would continue to be sampled for radioactivity. Any identified radioactivity will be evaluated for its source. If the source of the radioactivity is determined to be from plant operation, the sewage would not be released to the sewer system, but will be treated as radioactive waste.

3.14. Radioactive Waste

The 1995 FSER described changes in plans for the radioactive water treatment systems, which had occurred since the 1970s (TVA 1995b). Many of the systems described in that document were based on TVA's experience from SQN, which are comparable to the systems in use at WBN Unit 1. The updates in this section are based on TVA's operating experience at WBN Unit 1. Since hazardous waste handling equipment is either shared between units or would be similar, the processing of radioactive waste produced by the operation of Unit 2 would be performed in the same manner as Unit 1. Only minor changes have been made to the radioactive waste treatment system at WBN Unit 1 since 1995, and these changes do not alter the conclusions previously reached.

Liquid Radioactive Waste Treatment Systems

The 1995 FSER discussed attributes such as separation and processing of tritiated and nontritiated liquids, laboratory sample processing, and processing of waste from regeneration of condensate polishing demineralizer and spent resin. Since 1995, the boric acid evaporators and condensate demineralizer waste evaporator (CDWE) system have been deactivated and the functions have been replaced with the mobile waste demineralizer system described in the 1995 FSER. These changes are shown in Figure 3-10 for tritiated water and Figure 3-11 for nontritiated water (revised from Figure 4-1, TVA 1995b). The conclusion in the FSER that any releases from these systems would meet the requirements of the NPDES permit, 10 CFR 20, Appendix B; 10 CFR 50, Appendix I; and 40 CFR 190, as applicable, remain valid, and operation of WBN Unit 2 would not change this conclusion.

Gaseous Radioactive Waste Treatment Systems

The gaseous waste processing system is designed to remove fission product gases from the nuclear steam supply system and to permit operation with periodic discharges of small quantities of fission gasses through the monitored plant vent. No changes to equipment or operation have occurred and, therefore, the conclusions remain valid.

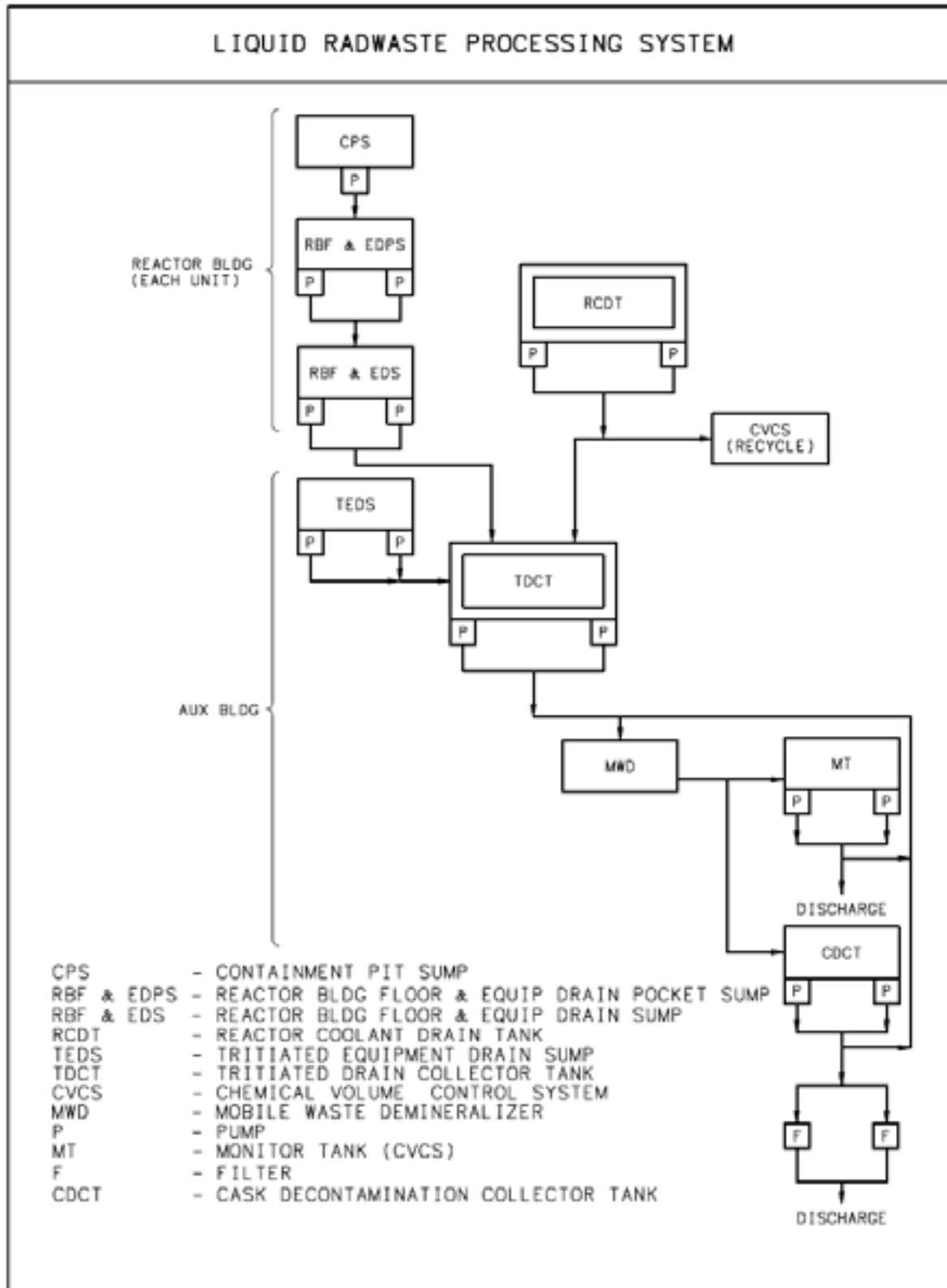

Figure 3-10. Liquid Radwaste Processing System – Simplified Flow Diagram for Tritiated Water

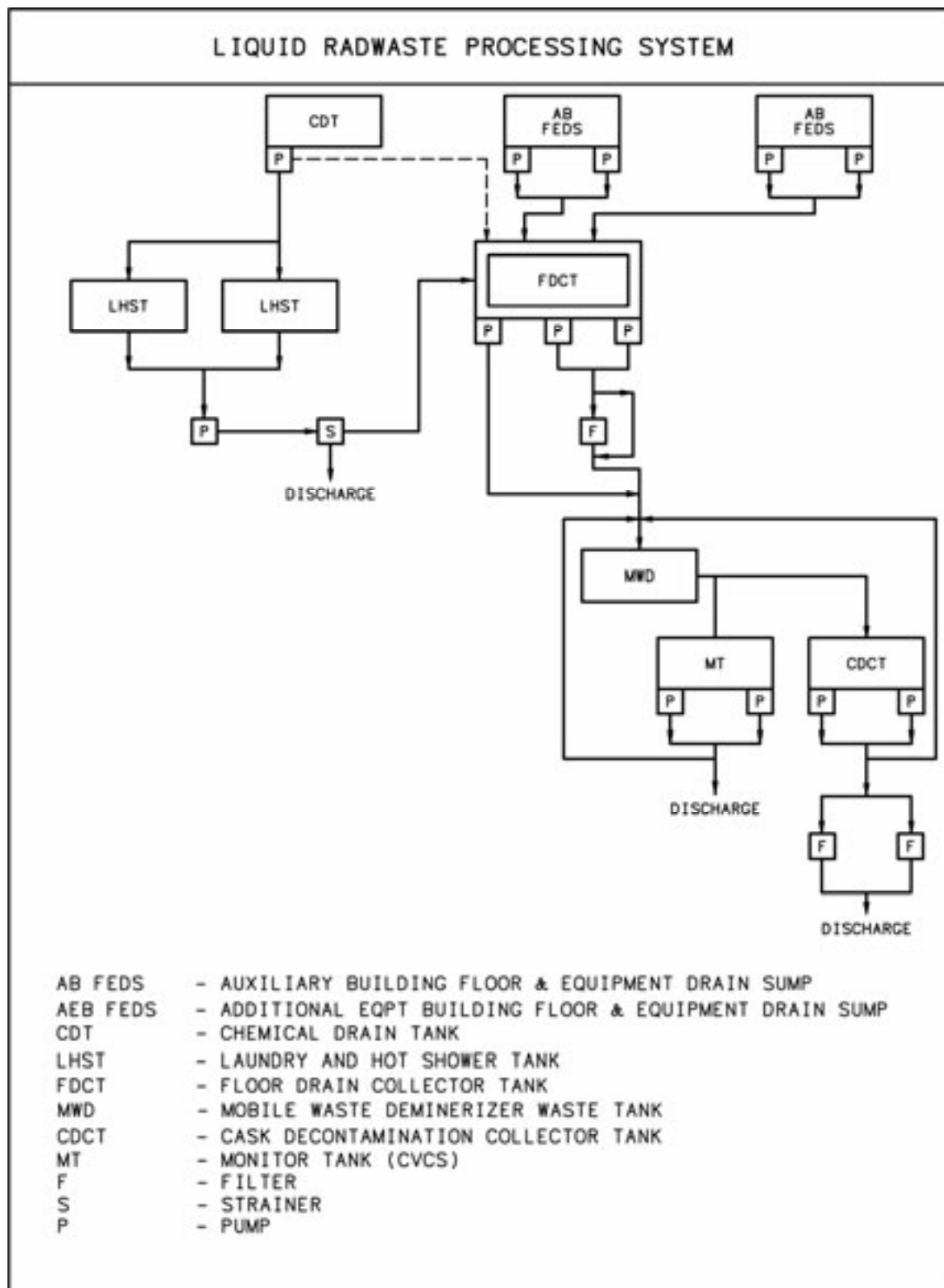

Figure 3-11. Liquid Radwaste Processing System – Simplified Flow Diagram for Nontritiated Water

Solid Radioactive Wastes

Radioactive waste (radwaste) generated from the operation of WBN Unit 2 would be handled in the same manner as radwaste from Unit 1. The solid radwaste disposal system (SRDS) processes and packages the dry and wet solid radioactive waste produced through power generation for off site shipment and disposal. The dry active waste (DAW) consists of compactable and noncompactable material. Compactable material includes paper, rags, plastic, mop heads, discarded clothing, and rubber boots. Noncompactable wastes include tools, pumps, motors, valves, piping, and other large radioactive components. The wet active wastes (WAW) consist of spent resins and filters. Radwaste is classified as either A, B, or C, with Class A being the least hazardous and Class C being the most hazardous. Class A includes both DAW and WAW. Classes B and C are normally WAW. The SRDS is a shared system between Units 1 and 2. The sharing does not inhibit the safe shutdown of one unit while the other unit is experiencing an accident. Some minor changes to the SRDS have occurred since 1995.

The 1995 FSER discusses solidification of resins and evaporator concentrates using cement and vermiculite. Evaporator concentrates are no longer generated at WBN due to the deactivation of the CDWE (see Liquid Radioactive Waste Treatment Systems, above). Handling of resins has not changed.

In 1995, TVA planned to send low-level radwaste to Barnwell, South Carolina, until a new disposal facility at Wake County, North Carolina, opened in mid-1998. This facility was not constructed. TVA has continued to ship all WAW (Classes A, B, and C) to the Barnwell facility and will do so through 2008 when that facility is scheduled to close. All DAW is currently shipped to a processor in Oak Ridge, Tennessee, for compaction and then by the processor to Clive, Utah, for disposal. Following 2008, Class A WAW will also be shipped to Clive, Utah. Class B and C waste will be shipped either to SQN, which is licensed to receive and store low-level radwaste from WBN, or to another licensed Class B and C radwaste disposal facility. WBN also has the option of compacting DAW on site. The shipping distances to these facilities are comparable or shorter than those analyzed in previous environmental reviews.

Transportation of Solid Waste

In the 1995 FSER, TVA used records documenting radioactive effluents and the results of off-site radiological monitoring at SQN to confirm the 1972 FES conclusion that insignificant environmental risk would result from the transportation of low-level waste to off-site disposal grounds is still valid. The exposures in Table 4-1 of the 1972 FSER were calculated from an estimated 43 shipments and 15,119 cubic feet of waste from SQN. WBN now has over 10 years of radwaste shipment records. During a one-year period ranging from May 2005-May 2006, there were eight shipments from WBN, for a total of 5120 cubic feet of waste. The addition of a second unit at WBN would result in a total of 16 shipments per year and 11,060 cubic feet of waste (Table 3-24). These figures represent 37.2 percent and 73.1 percent of the values presented in the 1995 FSER, and therefore, it can be expected that exposures to the truck driver and to the public would also range from 37.2 percent and 73.1 percent of the exposure estimated in the 1995 FSER. The 1995 FSER confirmed the conclusion in the 1972 FES that the environmental risk from transportation of low-level waste to off-site disposal grounds would be insignificant. Given that the number and size of shipments per year are less than previously projected, this conclusion is not changed.

Table 3-24. Maximum Anticipated Two-Unit Annual Solid Radwaste to be Processed

Waste Type	Volume (cubic feet)
Spent Resins and Filter Sludges	720
Filter Cartridges	240
Compactable and Noncompactable Trash	10,000
Contaminated Oil	100
Total	11,060

3.15. Spent Fuel Storage

The 1972 FES assumed that spent fuel would be shipped to the reprocessing plant in Barnwell, South Carolina. The 1993 review of the FES noted that reprocessing was no longer likely, and that TVA then “expected to store spent fuel on-site until the DOE completed the construction of storage or permanent disposal facilities in accordance with the Nuclear Waste Policy Act of 1982” (TVA 1993a). The revised plan was for TVA to provide additional storage capacity on site, if needed, until a licensed DOE facility became available. On-site storage of spent fuel was mentioned in the 1995 FES, but not in the 1995 FSEIS.

The need to expand on-site spent fuel storage at TVA nuclear plants was addressed when DOE prepared the CLWR FEIS (DOE 1999). This FEIS analyzed spent fuel storage needs at BFN Units 1, 2, and 3, SQN Units 1 and 2, and WBN Unit 1 and included a thorough review of the environmental effects of constructing and operating an on-site independent spent fuels storage installation (ISFSI). The present FSEIS incorporates by reference the spent fuel storage impact analysis in the CLWR FEIS and updates the analysis to include operation of WBN Unit 2.

Operation of a second unit at Watts Bar would increase the number of spent fuel assemblies generated at the site. For the purpose of this FSEIS, it is assumed that the additional spent fuel generated by the operation of a second unit would be accommodated at the site in a dry cask ISFSI. This generic ISFSI would be designed to store the number of additional spent nuclear fuel assemblies required for 40-year, two-unit operation at the reactor site. The additional fuel generated by the operation of Unit 2 would accelerate the schedule for on-site dry cask spent fuel storage expansion at WBN. To date, no ISFSI has been constructed at WBN. Under the current schedule for Unit 1, an ISFSI would be needed by 2018. Assuming WBN Unit 2 would begin operation in 2012, the ISFSI would be needed by 2015.

The CLWR FEIS assessed the number of dry storage casks needed to accommodate tritium production at WBN Unit 1 based on 24-pressurized water reactor spent nuclear fuel assembly capacity of four of the ISFSI cask designs in the United States at the time. Table 3-25 below updates Table 5-48 in the CLWR FEIS for WBN Unit 1 and adds data for Unit 2 to provide an estimated total number of casks that would be needed for 40 years of operation if WBN Unit 2 were completed. Although SQN has received licensing approval to use casks that can contain 32 spent fuel assemblies, this evaluation uses the more conservative 24-fuel assembly cask design capacity. Note that the data for WBN Unit 2 reflects the difference between a unit producing tritium (Unit 1) and one that would not produce tritium (Unit 2).

Table 3-25. Data for Number of ISFSI Casks Determination

Data Parameter	WBN Unit 1	WBN Unit 2
Operating cycle length	18 months	18 months
Fresh fuel assemblies per cycle – no tritium	80	80
Fresh fuel assemblies per cycle – maximum tritium	136	N/A
Increase in fresh fuel assemblies due to tritium	56	N/A
Number of operating cycles in 40 years ¹	27	27
Number of additional fuel assemblies for tritium	1512	N/A
Number of ISFSI dry casks needed to store fuel assemblies due to tritium production activities	63	0
Number of fuel assemblies for 40 year operation	2160	2160
Number of ISFSI dry casks needed to store fuel assemblies for spent fuel pool (SFP) capacity shortfall, ^{2,3}	27	90
Number of ISFSI dry casks needed to store fuel for each unit. ^b	90	90
Total number of ISFSI dry casks required for WBN site, two-unit operation	180	

¹ Forty years of operation covers 26 refueling outages and 27 operating cycles. Spent fuel is discharged 27 times from each unit.

² Number is based on 24 fuel assembly cask designs.

³ SFP capacity shortfall is based on existing SFP usable capacity of 1363 storage cells. The number of casks tabulated above for Unit 1 SFP capacity shortfall has been reduced from level projected in the CLWR FEIS to reflect actual tritium generation rates of fuel assemblies being less than originally estimated (56).

A number of ISFSI dry storage designs have been licensed by the NRC and are in operation in the United States, including facilities at TVA's SQN and BFN. Licensed designs include the metal casks and concrete casks. The majority of these operating ISFSIs use concrete casks. Concrete casks consist of either a vertical or a horizontal concrete structure housing a basket and metal cask that confines the spent nuclear fuel. Currently, there are three vendors with concrete pressurized water reactor spent nuclear fuel dry cask designs licensed in the United States, Holtec International, NAC International, and Transnuclear Inc. The Holtec International and NAC International designs are vertical concrete cylinders; whereas, the Transnuclear design is a rectangular concrete block. These designs store varying numbers of spent nuclear fuel assemblies, ranging from 24 to 37. However, since the Holtec design is currently being used at TVA's SQN and is representative of all other designs, the environmental impact of using the Holtec concrete dry storage ISFSI design has been addressed. As stated above, although the multipurpose canister (MPC)-32 is being used at SQN, this update has taken a more conservative approach using the MPC-24, since it would require more casks and correspondingly more concrete and steel.

The environmental analysis of spent fuel storage in the CLWR FEIS, which focused on dry storage casks, is still valid. The following sections update information about the equipment

vendors and processes currently used at WBN and provide analysis of the effects of completing WBN Unit 2 on spent fuel storage construction and operation.

3.15.1. Construction Impacts

The CLWR FEIS describes a NUHOMS-24P horizontal spent fuel storage module. Currently, HI-STORM vertical storage modules are used at SQN. For the purposes of this analysis, it is assumed that the same type of storage modules would be used at WBN. The modules used at SQN consist of cylindrical structure with inner and outer steel shells filled with concrete. The stainless steel MPC that contains the spent fuel assemblies is placed inside the vertical storage module. The MPC is fabricated off site.

The spent fuel storage site described for WBN Unit 1 in the CLWR FEIS was proposed to contain 63 spent nuclear fuel casks (see Table 3-25). Using the SQN ISFSI as a basis for calculating an appropriately sized pad, an area of approximately 55,800 square feet would be needed to store the 180 casks required to support a two-unit operation at WBN for 40 years. Assuming a proportionate ratio of area required for construction disturbance, nuisance fencing, and transport activities, a projected net disturbed area of approximately 2.2 acres would be required. The differences between constructions of an ISFSI for Unit 1 alone as compared to an ISFSI that would serve two units are shown in Table 3-26. Construction and installation of the HI-STORM modules would be similar to that described in the CLWR FEIS for the NUHOMS-24P, as would be the environmental effects. There is ample room at the WBN site to locate a storage facility.

Table 3-26. ISFSI Construction for Watts Bar Nuclear Plant Unit 1 as Compared to Construction of Both Units 1 and 2

Environmental Parameter	Unit 1 (from 1999 CLWR FEIS)	Units 1 & 2
External appearance	63 Horizontal storage modules Rectangular cubes 19 x 9.7 feet constructed on three concrete cask foundation pads approximately 116.4 x 38 feet	180 Vertical cylindrical storage modules (casks) placed on a concrete cask foundation pad of an approximate area of 55,800 square feet and 2 feet thick. Each cask would be a nominal 12 feet in diameter and 21 feet tall.
Health and safety (only construction work performed subsequent to the loading of any storage modules with spent fuel may result in worker exposures from direct and skyshine radiation in the vicinity of the loaded horizontal storage modules)	Dose rate: 0.5 mrem per hour ¹ Total dose during construction: 47.25 person-rem	Dose Rate: 0.5 mrem per hour ¹ Total dose during construction: 135 person-rem
Size of disturbed area	ISFSI footprint: 1.3 acres Disturbed: 5.3 acres	ISFSI footprint: 1.3 acres Disturbed: 2.2 acres
Materials (approximate)	Concrete: 10,618 tons Steel: 1,208 tons	Concrete: 27,675 tons Steel: 3150 tons

¹DOE 1999

3.15.2. Operational Impacts

The NUHOMS horizontal storage module dry cask system described in the CLWR FEIS was designed and licensed to remove up to 24 kilowatts (kW) of decay heat safely from spent fuel by natural air convection. The Holtec HI-STORM dry cask storage system currently in use at SQN is licensed to remove up to 28 kW of decay heat safely. Conservative calculations have shown that, for 24 kW of decay heat, air entering the cask at a temperature of 70°F would be heated to a temperature of 161°F. For a 28-kW maximum heat load, and assuming similar air mass flow rate through the cooling vents, the resulting temperature would be approximately 176°F. The environmental impact of the discharge of this amount of heat can be compared to the heat (336 kW) emitted to the atmosphere by an automobile with a 150-brake horsepower engine (Bosch 1976). The heat released by an average automobile is the equivalent of as few as 12 ISFSI casks at their design maximum heat load of 28 kW. Therefore, the decay heat released to the atmosphere from the spent nuclear fuel ISFSI is equivalent to the heat released to the atmosphere from approximately 15 average cars.

SQN has proposed and the NRC is reviewing the use of storage casks with a licensed maximum heat load of up to 40 kW. The use of this higher allowable maximum heat load cask would result in an increase from the values reported in the paragraph above. For example, for a 40 kW maximum heat load, and assuming similar air mass flow rate through the cooling vents results in a projected temperature of approximately 221°F. The heat released by an average automobile is the equivalent of as few as nine ISFSI casks at their proposed higher design maximum heat load of 40 kW. The decay heat released to the atmosphere from the spent nuclear fuel ISFSI would be equivalent to the heat released to the atmosphere from approximately 20 average cars. If approved, this type of cask could be used at WBN.

The CLWR FEIS concluded that the heat emitted from the WBN ISFSI would have no effect on the environment or climate because of its small magnitude. Although an ISFSI large enough to accommodate two-unit spent fuel storage would emit somewhat more heat, the amount is still negligible. The heat emitted by the fully loaded, largest projected ISFSI, even at the maximum design-licensed decay heat level for each cask of 28 kW, would be approximately 5000 kW (i.e., 180 casks × 28 kW = 5040 kW or 5.04 MW), as compared to 2000 kW for the system analyzed in 1999. This increase of 3000 kW of heat added to the atmosphere is not large enough to change the conclusion that this amount of heat is about 0.1 percent the heat released to the environment from any of the proposed nuclear power plants—on the order of 2,400,000 kW for each operating nuclear reactor. The actual decay heat from spent nuclear fuel in the ISFSI should be lower than 5000 kW and would decay with time due to the natural decay of fission products in the spent nuclear fuel. As stated in the CLWR FEIS, the incremental loading of the ISFSI over a 40-year period would not generate the full ISFSI heat until 40 years after the initial operation.

The proposed use of casks with higher allowable maximum heat load (40 kW) would result in an increase from the values reported above. For example, for a 40-kW maximum heat load, a site total of 7200 kW would represent about 0.15 percent of the heat released to the environment from any of the proposed nuclear power plants. Therefore, for the proposed 40-kW cask design, no noticeable effects on the environment or climate would be expected.

The differences between the operation of an ISFSI for Unit 1 alone as compared to an ISFSI that would serve two units are shown in Table 3-27. TVA has concluded that due to the small magnitude of the total potential dose, the radiation dose to workers from ISFSI

operation would be minor. In general, the operational effects of the HI-STORM modules would be similar to that described in the CLWR FEIS for the NUHOMS-24P, as would be the environmental effects.

Table 3-27. ISFSI Operation for Watts Bar Nuclear Plant Unit 1 as Compared to Operation of Both Units 1 and 2

Environmental Parameter	Unit 1 (from CLWR FEIS)	Units 1 and 2
Effects of operation of the heat dissipation system	Equivalent to heat emitted into the atmosphere by approximately 2-6 averaged-sized cars.	Equivalent to heat emitted into the atmosphere by approximately 15 average size cars, or 20 cars if the higher maximum heat load cask proposed at SQN is used.
Facility water use	Transfer cask decontamination water consumption of less than 946 cubic feet.	Transfer cask decontamination water consumption of less than 2703 cubic feet.
Radiological impact from routine operation	Worker exposure: As the result of daily inspection of casks, during a 40-year life cycle, workers would be exposed to 58.8 person-rem. Public exposure: The regulatory limit for public exposure is 25 mrem per year. Doses received by a member of the public living in the vicinity of the ISFSI would be well below the regulatory requirements.	Worker exposure: As the result of daily inspection of casks, during a 40-year life cycle, workers would be exposed to 168 person-rem. Public exposure: The regulatory limit for public exposure is 25 mrem per year. Doses received by a member of the public living in the vicinity of the ISFSI would be well below the regulatory requirements.
Radwaste and source terms	Cask loading and decontamination operation generates less than 126 cubic feet of low-level radioactive waste.	Cask loading and decontamination operation generates less than 360 cubic feet of low-level radioactive waste.
Climatological impact	Small (less than 0.1 percent of the nuclear power plant's heat emission to the atmosphere)	Small (approximately 0.1 percent of the nuclear power plant's heat emission to the atmosphere, or approximately .15 percent if 40 kW cask are used)
Impact of runoff from operation	The horizontal storage module surface is not contaminated. No contaminated runoff is expected.	The storage cask surface is not contaminated. No contaminated runoff is expected.

3.15.3. *Postulated Accidents*

The CLWR FEIS analyzed the postulated accidents that could occur at an ISFSI and concluded that the potential radiological releases would all be well within regulatory limits. The impact of the calculated doses, which were approximately 50 mrem or less for different scenarios, were compared with the natural radiation dose of about 300 mrem annually received by each person in the United States (DOE 1999). The storage casks proposed for use at WBN for a two-unit operation would be of similar or better design than those analyzed in the mid-1990s, and any accident doses resulting from such a postulated event would be consistent with doses previously determined.

3.16. **Transportation of Radioactive Materials**

The effects of transporting nuclear fuels and radioactive wastes are addressed in the 1972 FES. The 1995 FSER addressed the transportation of spent fuels and radioactive waste. The transportation of radioactive waste and spent fuel are addressed briefly in Section 3.14 and 3.15 of this document. The 1972 FES analysis was based on the annual shipment of about 100 tons of natural uranium. Analysis was based on 30 years of plant operation with annual refueling. As the FES explained, relatively low levels of radiation are emitted from

unirradiated new fuel assemblies. Therefore, the only exposure to people from the routine shipment of new fuel would be in direct view and to the individual truck drivers assigned. The exposure in the cab of the fuel transport truck was estimated to be 0.1 mrem per hour, and exposure to transportation personnel was estimated to be less than 1 mrem per shipment. This level would not cause any adverse effects. The FES also discussed accident potential, concluding that there would be no significant environmental risks from radiation resulting from an accident involving a shipment of new fuel (TVA 1972).

In the review of the FES, TVA concluded that the analysis of new fuel shipments in the 1972 FES was still valid at that time (TVA 1993a). When TVA applied for an operating license for WBN Unit 1, plans were for 40 years of operations, with refueling to occur every 18 months. The 1995 NRC FES stated that the proposed changes would result in a slight reduction in fuel usage as compared to the original application and that the changes would not alter the conclusion that the dose and potential health effects would be small compared to the effects of natural radiation doses (NRC 1995a).

Currently, 54 tons of new fuel is shipped annually to WBN Unit 1. If WBN Unit 2 were completed, for two-unit operation, there would be four reloads in three years, which would work out to 107 tons shipped annually. The 1972 FES indicated that fuel would most likely be shipped by truck, although transport by barge or rail was also considered. An estimated 10 shipments per year were expected, with up to seven shipping containers per load, each containing two fuel assemblies or a maximum of 14 assemblies per truck shipment. The FES discussed six shipping routes. Currently, TVA receives seven shipments per reload with a maximum number of assemblies per truck of 12, packed in six shipping containers. Westinghouse is developing new shipping containers and will only be able to ship 10 assemblies per truck in 10 shipping containers. They expect to be required to start using the new containers in 2009.

The *Environmental Survey of Transportation of Radioactive Materials to and from Nuclear Plants* (AEC 1972) and *Supplement 1* (NRC 1975) evaluated the environmental effects of transportation of fuel and waste for light water reactors and found the impacts to be small. These analyses provided the basis for Table S-4 in 10 CFR 51.52, which summarizes the environmental impacts of transportation of fuel and radioactive wastes to and from a reference reactor. Both normal conditions of transport and accidents are addressed in the table.

Subparagraph 10 CFR 51.52(a)(5) requires that unirradiated fuel be shipped to the reactor site by truck. A condition that the truck shipments not exceed 73,000 pounds as governed by federal or state gross vehicle weight restrictions is included in Table S-4. New fuel assemblies would be transported to WBN Units 1 and 2 by truck from a fuel fabrication facility, in accordance with U.S. Department of Transportation and NRC regulations. The initial fuel loading for Unit 2 would consist of 193 fuel assemblies. Every 18 months, refueling would require an average of 80 fuel assemblies. The fuel assemblies, which are fabricated at a fuel fabrication plant, would be shipped by truck to WBN shortly before they are required. Truck shipments would not exceed the applicable federal or state gross vehicle weight.

If WBN Unit 2 were completed, TVA would comply with all NRC, state, and federal requirements for transport of unirradiated fuel, as it does with fuel deliveries for Unit 1. The impacts of such deliveries on human health and the environment are expected to be minimal.

3.17. Decommissioning

Post-operational impact considerations were addressed in the 1972 FES (TVA 1972) under short-term versus long-term productivity and irreversible and irretrievable commitment of resources. Decommissioning is also addressed in the 1995 NRC FES (NRC 1995a) and TVA's 1995 FSER (TVA 1995b). As these documents explain, at the end of the operating life of the WBN units, TVA would seek the termination of its operating license from NRC. Termination requires that the units be decommissioned, a process that ensures the units are safely removed from service and the site made safe for unrestricted use. Consistent with the 1995 FSER, TVA is not proposing a decommissioning plan now. A decommissioning plan would be developed for approval by NRC, with appropriate environmental reviews, when TVA applies for decommissioning of these units in the future.

Methods

The three NRC-approved methods of decommissioning nuclear power facilities described in the 1995 FSER are still viable alternatives. These are:

1. **DECON.** The DECON option calls for the prompt removal of radioactive material at the end of the plant life. Under DECON, all fuel assemblies, nuclear source material, radioactive fission and corrosion products, and all other radioactive and contaminated materials above NRC-restricted release levels are removed from the plant. The reactor pressure vessel and internals would be removed along with removal and demolition of the remaining systems, structures, and components with contamination control employed as required. This is the most expensive of the three options.
2. **SAFSTOR.** SAFSTOR is a deferred decontamination strategy that takes advantage of the natural dissipation of almost all of the radiation. After all fuel assemblies, nuclear source material, radioactive liquid, and solid wastes are removed from the plant, the remaining physical structure would then be secured and mothballed. Monitoring systems would be used throughout the dormancy period and a full-time security force would be maintained. The facility would be decontaminated to NRC-unrestricted release levels after a period of up to 60 years, and the site would be released for unrestricted use. Although this option makes the site unavailable for alternate uses for an extended period, worker and public doses would be much smaller than under DECON, as would the need for radioactive waste disposal.
3. **ENTOMB.** As the name implies, this method involves encasing all radioactive materials on site rather than removing them. Under ENTOMB, radioactive structures, systems, and components are encased in a structurally long-lived substance, such as concrete. The entombed structure is appropriately maintained and monitored until radioactivity decays to a level that permits termination of the license. This option reduces worker and public doses, but because most power reactors will have radionuclides in concentrations exceeding the limits for unrestricted use even after 100 years, this option may not be feasible under current regulation.

It is expected that by the time WBN is decommissioned, new, improved technologies, including use of robotics, will have been developed and approved by NRC.

Cost

In 1995, NRC estimated that it would cost up to \$200 million to decommission a pressurized water reactor like WBN Units 1 and 2. NRC currently estimates that decommissioning

would cost up to \$366 million in today's dollars. TVA maintains a nuclear decommissioning trust to provide money for the ultimate decommissioning of its nuclear power plants. The fund is invested in securities generally designed to achieve a return in line with overall equity market performance. In June 1994, this fund had accumulated \$50 million. Since then, funds have been accumulated to cover the cost of decommissioning TVA's operating nuclear units. The assets of the decommissioning trust fund as of December 31, 2006, totaled \$1004 million. This balance is greater than the present value of the estimated future nuclear decommissioning costs for TVA's operating nuclear units. The present value is calculated by escalating the decommissioning cost in today's dollars by 4 percent per year through decommissioning. This liability is then discounted at a 5 percent real rate of return. This equates into an estimated decommissioning liability present value of \$699 million at calendar year end 2006. TVA monitors the assets of its nuclear decommissioning trust versus the present value of its liabilities and believes that, over the long term and before cessation of nuclear plant operations and commencement of decommissioning activities, adequate funds from investments will be available to support decommissioning.

At the time WBN Unit 2 commences operation, TVA would create a separate trust account for the unit within the decommissioning trust fund and would make any necessary contributions to the fund to cover the costs of future decommissioning.

Potential Impacts to the Environment

Environmental issues associated with decommissioning were analyzed in the *Generic Environmental Impact Statement for Licensing of Nuclear Power Plants*, NUREG-1437 (NRC 1996a; 1999). The generic environmental impact statement included a determination of whether the analysis of the environmental issue could be applied to all plants and whether additional mitigation measures would be warranted. Issues were sorted into two categories. For those issues meeting Category 1 criteria, no additional plant-specific analysis is required by NRC, unless new and significant information is identified. Category 2 issues are those that do not meet one or more of the criteria of Category 1 and therefore require additional plant-specific review. Environmental analysis of the future decommissioning plan for WBN would tier from this or the appropriate NRC document in effect at the time.

TVA has not identified any significant new information during this environmental review that would indicate the potential for decommissioning impacts not previously reviewed. Therefore, TVA does not at this time anticipate any adverse effects from the decommissioning process. As stated earlier, further environmental reviews would be conducted at the time a decommissioning plan for WBN is proposed.

CHAPTER 4

4.0 LIST OF PREPARERS

4.1. NEPA Project Management

Ruth M. Horton

Position: Senior NEPA Specialist, NEPA Services, TVA Environmental Stewardship and Policy, Knoxville, Tennessee
 Education: B.S., History
 Experience: 28 years in Public Policy and Planning, including 10 years in Environmental Impact Assessment
 Involvement: NEPA Compliance and Document Preparation

Bruce L. Yeager

Position: NEPA Program Manager, NEPA Policy, TVA Environmental Stewardship and Policy, Knoxville, Tennessee
 Education: M.S., Zoology (Ecology); B.S., Zoology (Aquatic Ecology)
 Experience: 31 years in Environmental Compliance for Water, Air, and Land Use Planning; Environmental Business Services
 Involvement: NEPA Policy Compliance and Document Preparation

4.2. Other Contributors

Steven F. Amick

Position: Specialist Engineer, Flood Risk and Data Management, River Operations
 Education/Experience: B.S., Civil Engineering with 30 years experience in the development floodplain data; Registered Professional Engineer
 Involvement: Floodplains and Flood Risk

John (Bo) T. Baxter

Position: Senior Aquatic Biologist, TVA Environmental Stewardship and Policy, Knoxville, Tennessee
 Education: M.S. and B.S., Zoology
 Experience: 17 years in Protected Aquatic Species Monitoring, Habitat Assessment, and Recovery; 7 years in Environmental Review
 Involvement: Aquatic Ecology/Threatened and Endangered Species

Stephanie A. Chance

Position: Biologist, Aquatic Endangered Species, TVA Environmental Stewardship and Policy, Knoxville, Tennessee
 Education: M.S., Environmental Biology; B.S., Fisheries Biology
 Experience: 7 years in Aquatic Biology; 3 years in Environmental Reviews
 Involvement: Aquatic Threatened and Endangered Species

Completion and Operation of
Watts Bar Nuclear Plant Unit 2

Jim Chardos

Position: Program Manager, Tritium Production, TVA Nuclear, Watts Bar Nuclear Plant, Spring City, Tennessee
Education: B.S., Rensselaer Polytechnic Institute; Executive MBA, Rutgers University
Experience: 6 years in the U.S. Nuclear Submarine Service; 37 years in Nuclear Plant Project Management
Involvement: Project Manager

Patricia B. Cox

Position: Senior Botanist, TVA Environmental Stewardship and Policy, Knoxville, Tennessee
Education: Ph.D., Botany (Plant Taxonomy and Anatomy); M.S. and B.S., Biology
Experience: 30 years in Plant Taxonomy at the Academic Level; 3 years with TVA Heritage Project
Involvement: Terrestrial Ecology, Invasive Plant Species, and Threatened and Endangered Species

Eric J. Davis

Position: Senior Financial Analyst, TVA Treasury - Finance, Knoxville, Tennessee
Education: A.S., Business Administration, B.S., Economics and Finance, M.B.A., General Management, C.F.A., Chartered Financial Analyst
Experience: 7 years in Treasury - Finance
Involvement: Decommissioning

James H. Eblen

Position: Contract Economist, TVA Environmental Stewardship and Policy, Knoxville, Tennessee
Education: Ph.D., Economics; B.S., Business Administration
Experience: 39 years in Economic Analysis and Research
Involvement: Socioeconomics and Environmental Justice

Michael A. Eiffe

Position: Specialist, TVA River Operations, Knoxville, Tennessee
Education: B.S., M.E., Civil and Environmental Engineering
Experience: 27 years in water resource systems analysis
Involvement: Surface Water Hydrothermal Analysis

Herbert V. Garrett Jr.

Position: Project Manager, TVAN - Nuclear Generation Development and Business Support
Education: B.S.M.E.
Experience: 27 years in Nuclear Engineering Design
Involvement: Radioactive Waste Treatment Systems

Travis Hill Henry

Position: Terrestrial Zoologist Specialist, TVA Environmental Stewardship and Policy, Knoxville, Tennessee
 Education: M.S., Zoology; B.S., Wildlife Biology
 Experience: 17 years in Zoology, Endangered Species, and NEPA Compliance
 Involvement: Terrestrial Ecology, Threatened and Endangered Species

Paul N. Hopping

Position: Technical Specialist, Reservoir Operations, Knoxville, Tennessee
 Education: Ph.D. Civil and Environmental Engineering; M.S. and B.S., Civil Engineering
 Experience: 23 years in Hydrothermal and Surface Water Analysis
 Involvement: Hydrothermal and Surface Water Analysis

Clinton E. Jones

Position: Aquatic Community Ecologist, TVA Environmental Stewardship and Policy, Knoxville, Tennessee
 Education: B.S., Wildlife and Fisheries Science
 Experience: 15 years in Environmental Consultation and Fisheries Management
 Involvement: Aquatic Ecology and Aquatic Threatened and Endangered Species

William Keeler

Position: Geographic Information System Specialist, TVA Environmental Stewardship and Policy, Knoxville, Tennessee
 Education: B.S., Communications, Geographic Information and Technology Certification
 Experience: 16 years experience in Geographic Information Systems
 Involvement: Mapping

W. Richard King

Position: Senior Project manager, TVA Facilities Management, Knoxville, Tennessee
 Education: Architectural design
 Experience: 39 years in Facilities Management and Master Planning
 Involvement: Site planning

Perry D. Maddux

Position: Project Manager, Nuclear Generation Development, Chattanooga, Tennessee
 Education: Bachelor of Chemical Engineering
 Experience: 24 years in Nuclear Design Activities
 Involvement: Spent Fuel Storage

Completion and Operation of
Watts Bar Nuclear Plant Unit 2

Zita I. Martin

Position: Spent Fuel Program Manager, Nuclear Fuel Supply and Disposal, Chattanooga, Tennessee
Education: B. S., Nuclear Engineering
Experience: 27 years in Nuclear Fuel, including 15 years dealing with Spent Fuel Storage
Involvement: Spent Fuel Storage

Roger A. Milstead

Position: Manager, TVA Flood Risk and Data Management, Knoxville, Tennessee
Education: B.S., Civil Engineering; Registered Professional Engineer
Experience: 30 years in Floodplain and Environmental Evaluations
Involvement: Floodplains and Flood Risk

Jason M. Mitchell

Position: Natural Areas Biologist, TVA Environmental Stewardship and Policy, Knoxville, Tennessee
Education: M.P.A. (Environmental Policy); B.S., Wildlife and Fisheries Science
Experience: 13 years in Natural Resource Planning and Ecological Assessment with Emphasis on Sensitive Resources
Involvement: Natural Areas

Jeffrey W. Munsey

Position: Civil Engineer (Dam Safety), TVA River Operations, Knoxville, Tennessee
Education: M.S. and B.S., Geophysics
Experience: 21 years in Geophysical and Geological Studies and Investigations, including Applications to Environmental Assessments
Involvement: Seismology

Jerri L. Phillips

Position: Chemistry/Environmental Technical Support, Watts Bar Nuclear Plant, Spring City, Tennessee
Education: M.S., Environmental Science
Experience: 9 years of Environmental Science experience, including Fresh/Salt Water Studies/Fieldwork Continentally and Abroad
Involvement: Raw Water Chemical Additives

Kim Pilarski

Position: Wetlands Biologist Specialist, TVA Environmental Stewardship and Policy, Knoxville, Tennessee
Education: M.S., Geography
Experience: 12 years in Watershed Assessment and Wetland Regulation and Assessment
Involvement: Wetlands

Doyle E. Pittman

Position: Program Manager, TVA Nuclear, Chattanooga, Tennessee
 Education: B.S., Atmospheric Science
 Experience: 30 years in Meteorological Support for Nuclear Power Plants
 Involvement: Climatology and Meteorology

Christopher D. Ungate

Position: Senior Consultant, Sargent & Lundy, Chattanooga, Tennessee
 Education: M.S. and B.S., Civil Engineering; M.B.A.
 Experience: 32 years in Engineering, Planning, and Management
 Involvement: Need for Power Analysis

Edward (Ted) W. Wells III

Position: Contract Archaeologist, TVA Environmental Stewardship and Policy, Knoxville, Tennessee
 Education: M.A. and B.S., Anthropology
 Experience: 8 years Cultural Resource Management
 Involvement: Cultural Resources

Cheryl K. Whitaker

Position: Health Physicist Radwaste, Watts Bar Nuclear Plant, Spring City, Tennessee
 Education: B.S., Radiation Protection
 Experience: 24 years in Radiation Protection, including 7 years in Radwaste
 Involvement: Radwaste

Eddie Woods

Position: Nuclear Chemist, Watts Bar Nuclear Plant, Spring City, Tennessee
 Education: B.S., Chemistry, M.B.A.
 Experience: 26 years in Nuclear Power Chemistry and Radiation Assessment
 Involvement: Radiological Effects

Page intentionally blank

CHAPTER 5

5.0 DISTRIBUTION OF DRAFT AND FINAL SEIS

5.1. List of Agencies, Organizations, and Persons to Whom Copies of the Draft or Final SEIS Were Sent and to Whom E-links Were Provided

Following is a list of agencies, organizations, officials, libraries and individuals to whom either published copies (bound or compact disc [CD]) of the DSEIS were provided, or Web links to an active TVA Web site from which the document can be accessed were sent. Those names with an asterix (*) received copies of both the FSEIS and DSEIS. Names of those who received only the FSEIS are listed at the end of this section.

Agencies/Individuals Receiving the DSEIS (Hard Copy or CD) and E-mail Notification of FSEIS Availability Including Active E-Link to TVA Web Site Address for the Document

Dr. Richard Allen
History and Culture Office
Cherokee Nation
Tahlequah, OK

Mr. Tyler Howe
Historic Preservation Specialist
Eastern Band of the Cherokee
Indians
Cherokee, NC

Mr. Russ Townsend
Tribal Historic Preservation Officer
Eastern Band of the Cherokee
Indians
Cherokee, NC

Ms. Lisa Stopp
Acting Tribal Historic Preservation
Officer
United Keetoowah Band of
Cherokee Indians in Oklahoma
Tahlequah, OK

Ms. Virginia (Gingy) Nail
Tribal Historic Preservation Officer
The Chickasaw Nation
Cultural Resources Department
Ada, OK

Mr. Terry Cole
Cultural Resources Director
Choctaw Nation of Oklahoma
Durant, OK

Chief Gregory E. Pyle
Choctaw Nation of Oklahoma
Durant, OK

Ms. Lillie Strange
Environmental Director
Jena Band of Choctaw Indians
Jena, LA

Ms. Joyce Bear
Historic Preservation Officer
Muscogee (Creek) Nation of
Oklahoma
Okmulgee, OK

Ms. Beryl Battise
Acting Tribal Historic Preservation
Officer
Alabama-Coushatta Tribe of
Texas
Livingston, TX

Ms. Augustine Asbury
Cultural Preservation Coordinator
Alabama-Quassarte Tribal Town
Wetumka, OK

Completion and Operation of
Watts Bar Nuclear Plant Unit 2

Ms. Evelyn Bucktrot
Mr. Gary Bucktrot
Tribal Historic Preservation Officer
Kialegee Tribal Town
Wetumka, OK

Ms. Robin DuShane
Cultural Preservation Director
Eastern Shawnee Tribe of
Oklahoma
Seneca, MO

Mr. Charles Coleman
NAGPRA Representative
Thlopthlocco Tribal Town
Weleetka, OK

Chief Charles Enyart
Eastern Shawnee Tribe of
Oklahoma
Seneca, MO

Ms. Karen Kaniatobe
Tribal Historic Preservation Officer
Absentee Shawnee Tribe of
Oklahoma
Shawnee OK

Mr. Ron Sparkman
Chairman
Shawnee Tribe
Miami, OK

Ms. Rebecca Hawkins
Tribal Historic Preservation Officer
Shawnee Tribe
Miami, OK

Agencies/Individuals Receiving the DSEIS and/or FSEIS (Hard Copy or CD)

U.S. Congressional Staff

Senator Lamar Alexander (Jeff Lewis - Staff)*

Senator Bob Corker (Betsy Renalli - Staff)*

Congressman Zach Wamp (Leigh McClure - Staff)*

U.S. (Federal) Officials

Dr. Lee Barclay, Field Supervisor*
U.S. Fish and Wildlife Service
Cookeville, Tenn.

Director, Office of Environmental Policy and Compliance*
Department of the Interior
Washington, D.C.

Mr. Ron Gatlin, Chief*
Regulatory Branch
U.S. Army Corps of Engineers
Nashville, Tenn.

Mr. Heinz Mueller, Chief*
Office of Environmental Assessment
U.S. Environmental Protection Agency, Region 4
Atlanta, GA

State and Local Agencies

Mr. Mike Apple, Director*
 Division of Solid Waste
 Tennessee Department of
 Environment and Conservation
 Nashville, Tenn.

Ms. Jennifer Bartlett*
 Tennessee Division of Archeology
 Nashville, Tenn.

Mr. Wilton Burnette*
 Tennessee Department of
 Economic and Community
 Development
 Nashville, Tenn.

Mr. Ed Cole, Chief,*
 Environment and Planning
 Tennessee Department of
 Transportation
 Nashville, Tenn.

Mr. Paul Davis, Director*
 Division of Water Pollution Control
 TDEC
 Nashville, Tenn.

Mr. Robert Foster, Director*
 Division of Water Supply
 TDEC
 Nashville, Tenn.

Commissioner James Fyke*
 TDEC
 Nashville, Tenn.

Pamala Myers*
 Environmental Protection
 Specialist
 TDEC-Water Pollution Control
 Nashville, Tenn.

Edward M. Polk, Jr., P.E*,
 Manager
 TDEC DWPC, Permit Section
 Nashville, Tenn.

Mr. Reggie Reeves, Director*
 Division of Natural Areas
 TDEC
 Nashville, Tenn.

Mr. Barry Stephens, Director*
 Division of Air Pollution Control
 TDEC
 Nashville, Tenn.

Mr. Robert Todd *
 Tennessee Wildlife Resources
 Agency
 Nashville, Tenn.

Mr. Richard Tune*
 Tennessee Historical Commission
 Nashville, Tenn.

State and Local Legislators and Officials

State Senator Dewayne Bunch (Meigs, McMinn, and Bradley Counties, Tenn.)*

State Senator Tom Kilby (Rhea County, Tenn.)*

State Representative Eric Watson (Meigs and Bradley Counties, Tenn.)*

State Representative Jim Cobb (Rhea and Hamilton County, Tenn.)*

Mayor Ken Jones, (Meigs County, Tenn.)*

Completion and Operation of
Watts Bar Nuclear Plant Unit 2

Mayor Billy Ray Patton (Rhea County, Tenn.)*

Mayor Kelly Reed (Spring City, Tenn.)*

Libraries

Chattanooga- Hamilton County Bicentennial Library
Chattanooga, Tenn. 37402

Knoxville Public Library / Lawson McGhee Library
Knoxville, TN 37902

Lenoir City Public Library
Lenoir City, Tenn.

Loudon Public Library
Loudon, Tenn.

Meigs - Decatur Public Library
Decatur, Tenn.

Clyde W. Roddy Public Library
Dayton, Tenn.

Audrey Pack Memorial Library
Spring City, Tenn.

E. G. Fisher Public Library
Athens, Tenn.

Cleveland Public Library
Cleveland, Tenn.

Persons Receiving E-mail Notification of DSEIS and FSEIS Document Availability Including Active E-Link to TVA Web Site Address for the Document

U.S. Congressional Staff

Mr. Todd Womack, staff of Senator Bob Corker

Mr. Patrick Jaynes, staff of Senator Lamar Alexander

Mr. David Leaverton, staff of Senator Lamar Alexander

Mr. Jonathan Griswold, staff of Congressman Jimmy Duncan

Ms. Beth Hickman, staff of Congressman Lincoln Davis

State and Local Legislators and Officials

State Senator Randy McNally (Loudon and Monroe Counties, Tenn.)

State Senator Bo Watson (Hamilton County, Tenn.)

State Senator Ward Crutchfield (Hamilton County, Tenn.)

State Representative Kevin Brooks (Bradley County, Tenn.)

State Representative Richard Floyd (Hamilton County, Tenn.)

State Representative Gerald McCormick (Hamilton County, Tenn.)

State Representative JoAnne Favors (Hamilton, County)

State Representative Tommie Brown (Hamilton, County)

State Representative Vince Dean (Hamilton, County)

State Representative Mike Bell (McMinn and Monroe Counties)

State Representative Jimmy Matlock (Loudon and Monroe, Counties)

State Representative Dennis Ferguson (Loudon County)

Bradley County Mayor Gary Davis

Hamilton County Mayor Claude Ramsey

Loudon County Mayor Doyle Arp

Knox County Mayor Mike Ragsdale

McMinn County Mayor John Gentry

Completion and Operation of
Watts Bar Nuclear Plant Unit 2

Monroe County Mayor Allan Watson
Roane County Mayor Mike Farmer
Chattanooga City Mayor Ron Littlefield
Knoxville City Mayor Bill Haslam

Additional Persons Receiving the FSEIS

Hard Copies or CDs

Dennis Beissel
Washington, DC

Joe McCarthy
Spring City, TN

Cathy Benog
Graysville, TN

Linda Modica
Jonesborough, TN

Howard Cohen
Knoxville, TN

Jerry Miller
Sale Creek, TN

Ken Jones
Decatur, TN

Bob Nordyke
Dayton, TN

Frances Lambert
Jonesborough, TN

E-mail Notification of Document Availability Including Active E-Link to TVA Web Site
Address for the Document

Terry Broyles
Spring City, TN

Thomas Markham
Lookout Mountain, GA

Andrew Eder
Knoxville, TN

Mac McMillan
Spring City, TN

Max Hackett
Dayton, TN

Zackery Rad
Soddy Daisy, TN

Cliff Hightower
Chattanooga, TN

Post Card

See Attachment A, Appendix D Response to Comments for a listing of those who sent
TVA a copy of a form letter by e-mail.

Ben McDonald
Spring City, TN

5.2. DSEIS Press Release

TVA Seeks Comments on Watts Bar Nuclear Plant Environmental Statement

April 6, 2007

SPRING CITY, Tenn. TVA is reviewing potential environmental impacts of the possible completion and operation of Unit 2 at Watts Bar Nuclear Plant near Spring City and has made a draft supplemental environmental impact statement available for public comment.

An open house on the draft supplemental environmental impact statement will be held April 17. The open house is scheduled from 4:30 p.m. to 8 p.m. at Rhea County High School in Evensville.

TVA is currently conducting a detailed cost and scheduling study on the feasibility of completing Unit 2 to help meet growing demand for power and to maximize the use of an existing asset. Unit 2 was more than half complete when construction was halted in 1985.

Under provisions of the National Environmental Policy Act, TVA prepared the draft supplemental environmental impact statement to update environmental reports previously prepared for the construction of the unit. Along with the detailed engineering and feasibility study currently under way, the environmental review will help TVA decide whether to complete the second unit at the plant. Unit 1 at Watts Bar began commercial operation in 1996.





The [draft supplemental environmental impact statement is available here](#) and also in many local libraries. It will be available at the open house April 17.

All written comments must be received by May 14. Comments may be submitted by mail to Ruth Horton, 400 Summit Hill Drive (WT-11D), Knoxville, TN 37902; on the [internet](#); or fax to (865) 632-3451.

Any comments received, including names and addresses, will become part of the administrative record and will be available for public inspection.

TVA is the nation's largest public power provider and is completely self financing. TVA provides power to large industries and 158 power distributors that serve approximately 8.7 million consumers in seven southeastern states. TVA also manages the Tennessee River and its tributaries to provide multiple benefits, including flood damage reduction, navigation, water quality and recreation.

5.3. Information Open House Paid Advertisement

		<i>fyi</i> from <i>tva</i>
		

**TVA Will Hold an Open House on the
Draft Supplemental Environmental Impact Statement
for the Completion of Unit 2 at Watts Bar Nuclear Plant**

TVA will hold an information open house at the Rhea County High School in Evensville, Tenn. about the draft Supplemental Environmental Impact statement (SEIS) for the possible completion of Unit 2 at Watts Bar Nuclear Plant. You are invited to stop by anytime from 4:30 p.m. to 8 p.m. EDT on April 17, 2007, during the open house to talk with TVA staff and submit comments about the draft document.

TVA is proposing to complete Unit 2 as a means to meet growing demand for power and to maximize the use of an existing asset. Unit 2 was more than half complete when construction was halted by TVA in 1985. The plant would be completed as designed using the existing buildings and infrastructure. Under provisions of the National Environmental Policy Act, TVA prepared the draft SEIS to update the environmental reports previously prepared for the construction of the unit. Along with the detailed engineering and feasibility study currently underway, this environmental review will help TVA decide whether or not to complete Unit 2.

The draft SEIS was prepared and made available for public review on March 30, 2007. Persons with Internet access can review it and submit comments at www.tva.gov/environment/reports/wattsbar2/. You can also request a copy by e-mailing trawattsbar2@tva.com or calling (423) 632-3719. Copies of the draft SEIS will be available at the open house and are also available at the following public libraries:

Chattanooga-Hamilton County Bicentennial Library
Knoxville Public Library / Lawson McGhee Library
Lenoir City Public Library
Loudon Public Library
Decatur Public Library
Clyde W. Roddy Public Library, Dayton
Audrey Pack Memorial Library, Spring City
E.G. Fisher Public Library, Athens
Cleveland Public Library

TVA is interested in receiving comments on the draft SEIS for consideration in completing the final SEIS. All comments need to be received by TVA no later than May 14, 2007. Any comments received, including names and addresses, will become part of the administrative record and will be available for public inspection.

Open house will be held in the gymnasium at Rhea County High School. The school is located north of Dayton, Tenn. in Evensville at 405 Pierce Road, about four-tenths of a mile west of Highway 27.

If any member of the public has special needs, please call the person listed below at least five days prior to the open house meeting.

Comments can be submitted online at www.tva.gov/environment/reports/wattsbar2/, e-mailed to trawattsbar2@tva.com, or mailed to:

Ruth Horton, Senior NEPA Specialist
400 Summit Hill Drive (WT-11D)
Knoxville, TN 37902
(865) 632-3719



5.4. Information Open House Handout
Information Open House
Draft Supplemental Environmental Impact Statement
Completion and Operation of Watts Bar Nuclear Plant Unit 2
Rhea County High School
April 17, 2007

Thank you for attending our information open house. The purpose of this meeting is to provide the opportunity for you to ask questions about the draft supplemental environmental impact statement (SEIS) and to make comments on TVA's analysis of the potential for environmental effects from completing Watts Bar Nuclear Plant Unit 2.

TVA is reviewing potential environmental impacts of the proposed completion and operation of Unit 2 at Watts Bar Nuclear Plant (WBN) near Spring City, Tennessee, and has made a draft SEIS available for public comment. Under provisions of the National Environmental Policy Act, TVA prepared the draft SEIS to update environmental reports previously prepared for the construction and operation of the unit. TVA will use information from both a detailed engineering and feasibility study currently underway and the SEIS to make an informed decision about whether or not to complete and operate Unit 2.

TVA encourages your comments on the draft SEIS. Please note that to be included in the official project record, comments must be received by TVA during the 45-day comment period. For ease of commenting, comments can be made today either orally to the court reporter or in writing on the attached mail-back comment form. Comments can also be submitted through TVA's web site, www.tva.gov/environment/reports/wattsbar2/, by e-mail tvawattsbar2@tva.com, by fax to 865-632-3451, or by surface mail to the address below. **Comments must be received no later than May 14, 2007.**

Ruth Horton
TVA NEPA Services
400 West Summit Hill Drive (WT-11D)
Knoxville, TN 37902.

Proposed Action

TVA is proposing completion and operation of WBN Unit 2 to meet the need for additional baseload capacity on the TVA system and to maximize the use of an existing assets. The unit would be completed as originally designed, alongside its twin, Unit 1, which began commercial operation in 1996. Only minimal new construction is proposed, and no expansion of the existing site footprint would be required.

Previous environmental reviews and studies have been completed to evaluate the potential environmental impacts associated with completion and operation of WBN Unit 2. This draft document supplements, verifies, and updates the information and analyses in those reviews. No effects beyond those discussed in previous environmental reviews were identified.

Fact Sheet

Watts Bar Nuclear Plant (WBN) is one of three licensed TVA nuclear power plant sites, and is located on 1700 acres at the northern end of Chickamauga Reservoir near Spring City, Tennessee.

Unit 1 on the plant site currently operates a Westinghouse pressurized-water reactor with a capacity of 1167 megawatts—enough electricity to supply about 650,000 homes. Unit 2 could provide more than 1150 megawatts of electricity in 2013.

Construction on Unit 2 was halted in 1985 and TVA subsequently focused its efforts on completing Unit 1. Currently in construction deferred status, Unit 2 is estimated to be about 60 percent complete.

Unit 2 is designed as a twin plant to the operating Unit 1 and would be completed and operated the same as Unit 1.

TVA holds a valid construction permit from the Nuclear Regulatory Commission for the completion of WBN Unit 2.

Completing Unit 2 would make use of existing buildings located on an operating nuclear plant site and would therefore would have less impact on the environment compared to new plant construction on a new site. No additional land would be needed to complete Unit 2.

TVA estimates completion of Unit 2 would cost between \$2 and \$3 billion dollars. This dollar amount will be refined in the Detailed Scoping, Estimating, and Planning (DSEP) study currently underway.

The draft SEIS estimates the peak construction and engineering workforce needed to complete Unit 2 would be roughly 2600, of which approximately 2200 would be on-site workers. Of these only 40 percent (900) workers would be expected to move into the area. The DSEP will provide a more complete workforce estimate.

Demand for electricity in the TVA power service area has grown at the average rate of 2.4 percent per year for the past 15 years. Future growth in demand is estimated to be around 2 percent annually.

TVA anticipates having to add baseload capacity to its system in the next decade to meet continued growth in demand for power.

No decision has been made to build any new base-load generation beyond completing Browns Ferry Unit 1.

Supplemental EIS Completion Schedule

Public Comment Period	March 30 – May 14, 2007
Public Scoping Meeting	April 17, 2007
Issue Final SEIS	June 22, 2007
Anticipated TVA Decision	August 2007

CHAPTER 6

6.0 SUPPORTING INFORMATION

6.1. Literature Cited

- Atomic Energy Commission. 1972. *The Environmental Survey of Transportation of Radioactive Materials to and from Nuclear Plants*. WASH-1238.
- Bosch, R. 1976. *Automotive Handbook*. Stuttgart, Germany: Robert Bosch GmbH Automotive Equipment Division, Department for Technical Publications.
- Baxter, D. S., K. D. Gardner, and G. D. Hickman. 2001. *Watts Bar Nuclear Plant Supplemental Condenser Cooling Water System Fish Monitoring Program*. Norris: Tennessee Valley Authority, Resource Stewardship.
- Calabrese, F.A. 1976. *Excavations at 40RH6 Watts Bar Area, Rhea County, Tennessee*. Chattanooga: University of Tennessee, Department of Sociology and Anthropology.
- Dynamic Solutions. 2007. *RFP 103006 Report Rev1 Watts Bar Unit 2 Thermal Effluent Study, prepared for TVA by Dynamic solutions, LLC. February 9, 2007*.
- Hadjerioua, B. and Lindquist, K. F. 2003. "Diffuser Design to Maximize Instantaneous Mixing of Elevated Ammonia Levels Discharged from KIF Ash Pond into the Intake Channel." Norris: Tennessee Valley Authority, Engineering Laboratory, WR2003-1-36-128.
- Jirka, Gerhard, H., R. L. Doneker, and S. W. Hinton. *User's Manual for CORMIX: A Hydrodynamic Mixing Zone Model and Decision Support System for Pollutant Discharges into Surface Waters*. Office of Science and Technology, U.S. Environmental Protection Agency. Washington, D.C.. September 1996.
- Karimi, R. 2007. *Watts Bar Nuclear Plant Severe Reactor Accident Analysis*. Germantown, Maryland: Science Applications International Corporation. Prepared by Science Applications International Corporation for TVA.
- Nuclear Energy Institute. 2002. *Aircraft Crash Impact Analyses Demonstrate Nuclear Power Plant's Structural Strength*.
- Schroedl, G. F. 1978. *Excavations of the Leuty and McDonald Site Mounds*. University of Tennessee Department of Anthropology, Knoxville Report of Investigations Number 22 and Tennessee Valley Authority Publications in Anthropology Number 15.
- Tennessee Valley Authority. 1972. *Final Environmental Statement, Watts Bar Nuclear Plant Units 1 and 2*. Chattanooga: Office of Health and Environmental Science.
- . 1976a. *Environmental Information, Watts Bar Nuclear Plant Units 1 and 2*. Supplement to Final Environmental Statement, Watts Bar Nuclear Plant Units 1 and 2 (TVA 1972). .

Completion and Operation of
Watts Bar Nuclear Plant Unit 2

- . 1976b. *Estimates of Entrainment of Fish Eggs and Larvae by Watts Bar Steam Plant, and Assessment of the Impact on the Fisheries Resources of Watts Bar Reservoir.*
- . 1976c. *Watts Bar Nuclear Plant, Final Safety Analysis Report, Amendment 23.*
- . 1977a. *Environmental Information, Supplement No. 1, Responses to NRC Questions for Operating License State Environmental Review, Watts Bar Nuclear Plant Units 1 and 2.*
- . 1977b. *Effects of Watts Bar Nuclear Plant and Watts Bar Steam Plant Discharges on Chickamauga Lake Water Temperatures, Tennessee Valley Authority, Division of Water Management, Water Systems Development Branch, Report No. WM28-1-85-100, February 1977.*
- . 1977c. *Results of Hydrothermal Model Test of the Multiport Diffuser System Watts Bar Nuclear Plant, Tennessee Valley Authority, Division of Water Management, Water Systems Development Branch, Report No. 9-2013, May 1977.*
- . 1980a. *Environmental Assessment for Low-Level Radwaste Management, Watts Bar Nuclear Plant.*
- . 1980b. *Watts Bar Waste Heat Park, Rhea County Tennessee, Volumes 1 and 2.*
- . 1986. *Preoperational Assessment of Water Quality and Biological Resources of Chickamauga Reservoir, Watts Bar Nuclear Plant, 1973-1985.* Chattanooga: Office of Natural Resources and Economic Development, Division of Air and Water Resources.
- . 1989. *Proposed Incinerator for Burning Low-Level Radioactive Waste.*
- . 1993a. *Review of Final Environmental Statement, Watts Bar Nuclear Plant, Units 1 & 2.*
- . 1993b. *Discharge Temperature Limit Evaluation For Watts Bar Nuclear Plant.* Report No. WR28-1-85-137. .
- . 1994a. *Tennessee Valley Reservoir and Stream Quality – 1993. Summary of Vital Signs and Use Suitability Monitoring.* Norris: Office of Water Management.
- . 1994b. *Watta Bar Off-Site Dose Calculation Manual. A 20-year Period of Meteorological Data From 1974-1993.* Approved by the U.S. Nuclear Regulatory Agency July 26, 1994.
- . 1995a. *Energy Vision 2020 - Integrated Resource Management Plan and Final Programmatic Environmental Impact Statement.*
- . 1995b. *Final Supplemental Environmental Review, Operation of Watts Bar Nuclear Plant.* Chattanooga: Tennessee Valley Authority.

- . 1995c. *Adoption of Final Supplemental Environmental Impact Statement*, 60 FR 35577. Adoption of NRC 1995a.
- . 1995d. *Record of Decision – Operation of Watts Bar Nuclear Unit 1*.
- . 1997a. *Lead Test Assembly Irradiation and Analysis, Watts Bar Nuclear Plant, Tennessee, and Hanford Site, Richland, Washington - Adoption of U.S. Department of Energy Environmental Assessment and Finding of No Significant Impact*. EA-1210.
- . 1997b. *Watts Bar Nuclear Plant Supplemental Condenser Cooling Water Project Thermal Plume Modeling, Tennessee Valley Authority, Engineering Laboratory, December, 1997*.
- . 1998a. *Final Environmental Assessment Related to the Watts Bar Nuclear Plant Supplemental Condenser Cooling Water Project*. Knoxville: Office of Environmental Policy and Planning.
- . 1998b. *Aquatic Environmental Conditions in the Vicinity of Watts Bar Nuclear Plant During Two Years of Operation*. Norris: Office of Water Management.
- . 1998c. *Individual Plant Examination of External Events (IPEE) Final Report*.
- . 1998d. *1997 Verification of Thermal Discharge For Watts Bar Nuclear Plant*. Report No. WR98-2-85-141.
- . 1998e. *Hydrodynamics and Water Temperature Modeling at Watts Bar SCCW Discharge Structure, Report No. WR98-1-85-142, Tennessee Valley Authority, Engineering Laboratory, November, 1998*.
- . 1999a. *Low Level Radioactive Waste Transport and Storage, Watts Bar and Sequoyah Nuclear Plants*.
- . 1999b. *July 1999 Verification Study of Thermal Discharge for Watts Bar Nuclear Plant Supplemental Condenser Cooling Water System*. Report No. WR99-2-85-143.
- . 2000. *Record of Decision and Adoption of the Department of Energy Final Environmental Impact Statement for the Production of Tritium in a Commercial Light Water Reactor*.
- . 2001. *Hydrothermal Data For Watts Bar Nuclear Plant SCCW Outfall*. Report No. WR2001-4-85-145.
- . 2002. *Final Supplemental Environmental Impact Statement for Operating License Renewal of the Browns Ferry Nuclear Plant*.
- . 2004a. *Reservoir Operations Study Final Programmatic Environmental Impact Statement*.

Completion and Operation of
Watts Bar Nuclear Plant Unit 2

- . 2004b. *Proposed Modifications to Water Temperature Effluent Requirements for Watts Bar Nuclear Plant Outfall 113*. Report No. WR2004-3-85-149.
 - . 2004c. *Increase in Allowable UHS Temperature to 88°F, TVA Categorical Exclusion Checklist No. 4569, Closed February 20, 2004*.
 - . 2004d. *Watts Bar Nuclear Plant, Final Safety Analysis Report, Amendment 5*.
 - . 2005a. *Final Environmental Assessment, Watts Bar Nuclear Plant Unit 1, Replacement of Steam Generators, Rhea County, Tennessee*.
 - . 2005b. *Watts Bar Nuclear Plant to Spring City Sewer Pipeline Project Final Environmental Assessment and Finding of No Significant Impact*.
 - . 2005c. *Watts Bar Nuclear Plant National Pollutant Discharge Elimination System (NPDES) Permit TN0020168*. Effective February 15, 2005, expires November 4, 2006.
 - . 2005d. *Draft Environmental Impact Statement for Watts Bar Reservoir Land Management Plan, Loudon, Meigs, Rhea, and Roane Counties, Tennessee*. May 2005. ..
 - . 2005e. *Winter 2005 Compliance Survey for Watts Bar Nuclear Plant Outfall 113 Passive Mixing Zone*. Report No. WR2005-2-85-151.
 - . 2006a. *Summer 2005 Compliance Survey for Watts Bar Nuclear Plant Outfall 113 Passive Mixing Zone*. Report No. WR2005-2-85-152.
 - . 2006b. *Watts Bar Nuclear Plant (WBN) - Unit 1 - Technical Specification (TS) Change TS-06-09, "Revision Of Ultimate Heat Sink (Uhs) Temperature", TVA letter to U.S. Nuclear Regulatory Commission, May 8, 2006*.
 - . 2007a. Discussions about WBN operation with two units, wherein TVA engineers indicated that the average operation of the IPS is expected to be equivalent to about 4 ERCW pumps and 2 RCW pumps. J.S. Chardos, F.A. Koontz, P.N. Hopping, R.M. Horton, S.E. Woods, J.S. Thompson, and J.L. Phillips. June 7, 2007.
 - . 2007b. *Winter 2006 Compliance Survey for Watts Bar Nuclear Plant Outfall 113 Passive Mixing Zone*.
 - . 2007c. *Summer 2006 Compliance Survey for Watts Bar Nuclear Plant Outfall 113 Passive Mixing Zone*.
- U.S. Department of Commerce. 2003. *Climatology of the U.S., No. 81, Monthly Station Normals*. National Climatic Data Center, CLIM 81, September 8, 2003.
- . 2005. *Local Climatological Data Annual Summary Comparative Data for Chattanooga, Tennessee*. National Climatic Data Center.
- U.S. Department of Energy. 1999. *Final Environmental Impact Statement for the Production of Tritium in a Commercial Light Water Reactor*.

- U.S. Nuclear Regulatory Commission. 1975. *Environmental Survey of Transportation of Radioactive Materials to and from Nuclear Power Plants, Supplement 1*. NUREG-75/038.
- . 1977. *Calculation of Annual Doses to Man From Routine Releases of Reactor Effluents for the Purpose of Evaluating Compliance with 10 CFR Part 50, Appendix I*. NRC Regulatory Guide 1.109, October 1977.
- . 1978. *Final Environmental Statement Related to the Operation of Watts Bar Nuclear Plant Units 1 and 2*. NUREG-0498. Washington, D.C.: Office of Nuclear Reactor Regulation.
- . 1995a. *Final Environmental Statement Related to the Operation of Watts Bar Nuclear Plant Units 1 and 2*. NUREG-0498. Washington, D.C.: Office of Nuclear Reactor Regulation.
- . 1995b. *Final Environmental Statement Related to the Operation of Watts Bar Nuclear Plant, Units 1 and 2, Supplement No. 1*. NUREG-0498, Docket Nos. 50-390 and 50-391. Washington, D.C.: Office of Nuclear Reactor Regulation.
- . 1996a. *Generic Environmental Impact Statement for License Renewal of Nuclear Plants*. NUREG-1437, Washington, D.C.
- . 1996b. *Preparation of Radiological Effluent Technical Specifications for Nuclear Power Plants*. NRC Report Number: NUREG-0133, Rev. 2. Prepared for Office of Public Affairs U.S. Nuclear Regulatory Commission Washington, DC 20555-0001. Date Published: February 1996.
- . 1999. *Generic Environmental Impact Statement for License Renewal of Nuclear Plants*. Main Report, Section 6.3 – Transportation, Table 9.1, Summary of Findings on NEPA Issues for License Renewal of Nuclear Power Plants. NUREG-1437, Volume 1. Washington, D.C.
- . 2007. *Additional Comments on SECY-06-0219, Final Rulemaking to Revise 10 C.F.R. 73.1, Design Basis Threat Requirements*, Commissioner McGaffigan. January 29, 2007.

6.2. Index

accident	S-4, ii, iii, 5, 31, 73, 74, 75, 76, 94, 99, 100, 121, 168, 171, 187, 189
airborne effluent	90
airborne release	89, 90
airborne releases	89
bald eagle	3, 28, 30, 60
bald eagles	3, 30, 60
baseload capacity	S-3, 1, 14, 15, 117, 118, 180
biocides	46, 47, 49, 53
blowdown	ix, 23, 24, 26, 35, 38, 39, 49, 52, 59, 81, 131, 202, 210
Browns Ferry Nuclear Plant (BFN)	vii, 5, 9, 14, 95, 96, 123, 188
capacity	S-3, S-1, v, 1, 5, 8, 11, 13, 14, 15, 16, 19, 23, 24, 52, 59, 67, 72, 95, 96, 118, 162, 163, 165, 177, 188, 190, 192, 205, 211
capacity factor	8, 14, 15, 19, 162
cask	iv, 95, 96, 97, 98, 99, 205, 206
Chickamauga Reservoir	iv, v, 1, 28, 34, 38, 45, 46, 54, 55, 56, 58, 61, 62, 69, 79, 118, 122, 131, 150, 152, 153, 202
Commercial Light Water Reactor (CLWR)	S-1, vii, 7, 8, 33, 95, 96, 97, 98, 99, 123, 124, 163, 180, 187
condenser cooling water (CCW)	S-2, vii, 5, 21, 23, 24, 26, 29, 49, 52, 54, 187, 202, 209
construction employment	64
cooling tower	8, 20, 21, 23, 24, 34, 37, 40, 42, 49, 52, 59, 62, 131, 174, 210
cost of power	1, 10, 11, 15, 17, 19, 179, 187, 193
cumulative effect	4, 8, 28, 29, 33, 45, 46, 68
decommissioning plan	101, 102
Department of Energy	S-1, vii, 1, 7, 123, 124
Department of Energy (DOE)	S-1, S-4, vii, 1, 5, 7, 8, 95, 99, 123, 124, 177, 180, 187, 191
design basis	2, 3, 29, 30, 52, 71, 73, 163, 177, 211
Detailed Scoping, Estimating, and Planning (DSEP)	S-3, 1, 5, vii, 1, 20, 31, 118, 176, 178, 187
diffuser	23, 26, 34, 35, 37, 49, 50, 59, 121, 122, 131, 132, 202, 203
discharge	S-2, S-3, iii, vii, ix, 23, 24, 26, 29, 30, 34, 35, 37, 39, 40, 41, 42, 44, 45, 46, 48, 49, 50, 51, 52, 53, 55, 59, 76, 80, 87, 91, 98, 121, 122, 123, 124, 131, 132, 133, 134, 163, 196, 202, 209, 210
discharge limit	26, 46, 48, 49, 55, 59
discharges	37, 45, 55, 59, 91
distributor	5, 12, 115, 178
distributors	5
dose	iii, iv, 51, 73, 74, 76, 77, 79, 81, 84, 85, 89, 90, 97, 98, 99, 100, 101, 122, 125, 211
doses	73, 76, 77, 81, 85, 89, 90, 98, 99, 100, 101
dry storage	75, 95, 96
earthquake	69, 71, 72, 75, 76, 177
economic growth	12
effluent	S-2, iii, v, x, 23, 24, 29, 34, 35, 36, 39, 40, 41, 42, 43, 44, 45, 46, 48, 49, 53, 76, 77, 81, 82, 84, 85, 88, 89, 90, 94, 121, 124, 125, 131, 132, 133, 134, 202, 210
emission	1, 10, 11, 14, 15, 19, 32, 33, 73, 99, 189, 191, 192
emissions	1, 19, 33, 73
entrainment	54, 55, 57, 59, 122, 179, 202
essential raw cooling water (ERCW)	S-2, viii, 29, 43, 47, 48, 49, 52, 124
far-field effect	34, 45, 131, 132
far-field effects	34, 45, 131, 132
federally listed	3, 11, 28, 30, 57, 59, 60, 202
federally listed species	11
Final Safety Analysis Report (FSAR)	viii, 5, 69, 71, 73, 81, 84, 89, 90, 122, 124, 177
Fish and Wildlife Service	x, 10

fish passage	43, 45, 132, 133
flood risk	70
fuel type	13, 16
gaseous	iii, v, 85, 86, 87, 88, 89, 91
gaseous effluent	85, 87
generating capacity	5, 11, 14, 190
gray bats	3, 28, 30, 60
groundwater	S-2, i, 9, 21, 30, 53
hazardous waste	91
heat dissipation	21, 23, 26, 34, 37, 99, 131, 132, 134
heat load	43, 98, 99
herons	28, 60
housing	3, i, 31, 65, 66, 67, 96, 162, 176
human health	74, 100
hydrothermal	S-2, S-4, i, ii, iii, 26, 29, 33, 34, 35, 37, 38, 39, 40, 41, 42, 43, 45, 46, 59, 104, 105, 122, 123, 129, 131, 133, 134, 163, 209
impingement	202
inake flows	3, 24, 30, 55, 59
income	S-3, i, 31, 65, 66, 162, 176
instream temperatures	26, 35, 39, 40, 132, 134
Integrated Resource Management Plan	S-1, viii, 6, 8, 122
Integrated Resource Management Plan (IRP)	S-1, viii, 6, 8, 122
IRP	viii, 8, 11, 14, 19, 162, 169, 170, 176, 178, 188
liquid effluents	77, 81, 85
liquid radwaste	81
load forecast	11, 12, 15
low-level radwaste	94
macrofouling	48, 49
maximum flow	23, 38, 203
Meigs County	28, 61, 64, 65, 66, 68, 111
microbiological	48, 49
minimum flow	26, 35, 202, 203
mixing zone	26, 34, 35, 37, 38, 59, 131, 132, 133, 134, 187, 210, 211
mussel sanctuary	10, 55, 57, 61
mussels	S-3, iv, v, viii, 10, 28, 30, 35, 43, 48, 49, 55, 56, 57, 58, 59, 61, 154, 155, 156, 202, 203, 210
near-field effects	34, 131
nontritiated	v, 91, 93
NPDES permit	2, 4, 24, 26, 29, 33, 34, 35, 43, 46, 49, 53, 91, 131, 132, 133, 134, 175, 202, 210, 211
peak load	15, 16
permit limits	2, 4, 29, 34
plume	74, 123, 132, 133, 134
population growth	5, 12, 32, 64, 68
poverty level	66
pressurized water reactor	95, 96, 101
probabilistic safety assessment	73
radioactive waste treatment	91
radiological effect	77, 182, 211
radiological effects	77
radiological impact	74, 85, 90, 99
radiological impacts	74
radiological plume	74
radiological release	73, 74, 99
radiological releases	74
radiological waste	51

Completion and Operation of
Watts Bar Nuclear Plant Unit 2

radionuclides	75, 76, 77, 81, 85, 101
radwaste	iv, v, viii, ix, 6, 10, 51, 81, 83, 92, 93, 94, 95, 99, 107, 122, 173
raw water	2, 29, 46, 47, 48, 49, 52, 202, 210
raw water chemical additives	52
reactor coolant system (RCS)	ix, 50, 51
reprocessing plant	95
Reservoir Operations Study (ROS)	S-1, ix, 7, 8, 33, 34, 37, 38, 39, 40, 41, 42, 45, 123, 134
Rhea County	S-1, S-3, iii, 1, 6, 7, 10, 60, 64, 65, 66, 67, 68, 69, 73, 111, 112, 115, 117, 121, 122, 124, 178
safety	S-4, ii, ix, 5, 8, 9, 10, 27, 31, 48, 69, 70, 73, 76, 97, 106, 162, 167, 169, 170, 171, 176, 177, 179, 181, 187
schools	S-3, i, 10, 31, 67, 68, 69, 115, 117, 162, 176, 178
security	S-4, ii, 9, 31, 70, 73, 75, 76, 101, 161, 162, 163, 169, 170, 180, 181, 187
seismic	3, ii, 9, 31, 71, 72, 177
Sequoyah Nuclear Plant (SQN)	ix, 7, 8, 19, 20, 79, 91, 94, 95, 96, 97, 98, 99, 123, 132
severe accident	73, 74, 75, 76
shipment	94, 99, 100, 206
shipments	94, 100
spent fuel	4, 10, 21, 31, 33, 95, 96, 97, 98, 99, 162, 163, 169, 170, 171, 173, 180, 181, 182, 187, 192, 205, 206
state-listed	3, 28, 30, 57, 59, 60
state-listed species	57
steam generator	5, 21, 37, 39, 40, 41, 42, 44, 45, 51, 52, 59, 202
storage module	97, 98, 99
storage modules	97
Supplemental Condensor Cooling Water (SCCW) ..	S-2, iii, ix, 5, 8, 21, 23, 24, 26, 29, 34, 35, 37, 38, 39, 40, 41, 42, 43, 44, 45, 46, 49, 54, 62, 123, 131, 132, 133, 134, 163, 187, 202, 209, 210
surface water	3, 4, 30, 33, 46, 55, 59, 182
surfactants	46, 48
tailwater	54, 55, 56, 202
tax equivalent payments	31, 66, 68, 163, 176
tax revenue	68, 163, 176
temperature limits	34, 44, 45, 131, 132, 133, 134
terrorist	4, 31, 75, 76, 162, 163, 168, 170, 180, 189
thermal discharge	55, 59, 131, 132, 133
thermal effluent	34, 36, 37, 39, 40, 44, 45, 131, 132, 133
threatened and endangered	S-3, i, 9, 30, 57, 103, 104, 105, 203
tiering	i, 5, 19
transmission	9, 20, 27, 28, 29
transportation	S-4, ii, 9, 31, 33, 75, 94, 99, 100, 111, 121, 125, 163, 173, 181, 191
tritiated	v, 91, 92
turbine building	21, 46, 52, 59, 71
U.S. Fish and Wildlife Service (USFWS)	x, 10, 59, 110, 202
Vital Signs Monitoring Program	iv, 45, 54, 55, 153, 211
waste heat	21, 23, 24, 34, 44, 45, 174
water intake	2, 20, 21, 29, 54, 55, 59
Watts Bar Reservoir	iv, 54, 60, 68, 122, 124, 153, 202
workforce	5, 21, 31, 64, 66, 67, 118, 176

**APPENDIX A – SUMMARY OF PREVIOUS HYDROTHERMAL
IMPACT STUDIES**

Page intentionally blank

Summary of Previous Hydrothermal Impact Studies

Numerous studies have been performed over the years to evaluate the impact of WBN heated effluent on the Tennessee River. The following provides a summary of key findings.

1972 Final Environmental Statement (FES)

The 1972 FES contains an analysis of the WBN heat dissipation system with operation of both Unit 1 and Unit 2. The analysis focused on the discharge from the Outfall 101 diffusers, since Outfall 102 releases are infrequent and the SCCW system (Outfall 113) was not an option at that time. TVA determined that the controlling criterion for the discharge of the plant thermal effluent would be the limit for the maximum temperature rise in the receiving waters. A simple mass balance calculation under assumed worst-case conditions was presented to show that this criterion would not be violated. The analysis did not consider any specific reservoir operating policy for the river other than to assume that no thermal effluent would be released to the receiving waters when the discharge from WBN is less than 3500 cubic feet per second (cfs). The primary conclusions reached in the 1972 FES were that the operation of WBN Unit 1 and Unit 2 would not cause violations of the receiving water temperature limits for Outfall 101 (i.e., near-field effects) and that the operation of WBN Unit 1 and Unit 2 are not expected to have any noticeable impact on Chickamauga Reservoir (i.e., far-field effects).

1993 TVA Review of Final Environmental Statement

The identification of potential impacts that changed or were likely to change from the original 1972 FES was addressed by TVA's 1993 review. In the review, none of the "changed or potentially changing" impacts were found to be related to the heat dissipation system. In fact, the 1993 review specifically stated that the original analysis and assumptions for cooling tower blowdown and heat dissipation were still valid for preserving the NPDES effluent limits for Outfall 101. The review, however, did provide preliminary information about the Outfall 101 mixing zone, describing it as extending less than 100 meters downstream from the diffusers and influencing less than 40 percent of the cross-sectional area of the river at normal summer elevations.

1993 Discharge Temperature Limit Evaluation for Watts Bar Nuclear Plant

The plant NPDES permit of 1993 required TVA to conduct a study to determine appropriate daily average temperature limits for releases from Outfall 101 and Outfall 102. The report was completed and submitted to the State of Tennessee in December 1993 (TVA 1993b). In contrast to previous evaluations, the study included detailed model simulations of the combined hourly operation of the plant and the Tennessee River. Evaluations were performed for the operation of both units at WBN and considered cases with and without the operation of WBF, located 1.5 miles upstream. At that time, WBF was in a "mothballed" status, and given the uncertainty of its future, it was considered worthwhile to examine a worst-case scenario including thermal discharges from both WBF and WBN. (Note: Since 1993, WBF has been retired.) The simulations were performed for historical river conditions and historical meteorology for a 17-year period from January 1976 through October 1993.

Based on the model simulations, a flow-weighted daily average temperature limit of 95°F (35°C) was recommended by TVA for Outfall 101. For Outfall 102, a limit of 104°F (40°C) was recommended for any single grab sample. The recommendations were based on preserving instream water quality standards specified by the State of Tennessee (see

Section 2.2.2). In the study, the instream temperatures were computed at the downstream end of mixing zones for each outfall. For Outfall 101, the assumed mixing zone was 240 feet wide and extends downstream 240 feet. For Outfall 102, the recommended mixing zone was 1000 feet wide and 3000 feet downstream.

Due to the length of the diffusers for Outfall 101 (e.g., less than one-fourth the width of the river), and the small effect from surface discharge for Outfall 102 (e.g., heated effluent resides in the surface layer of the river), the 1993 study concluded that ample space exists for fish passage during all operating conditions of WBN.

For far-field effects, the study examined the impact of the combined operation of WBF and WBN on water temperature at SQN, located 43 miles downstream of WBN. Using hydrology and meteorology corresponding to 1986 (a hot, dry year), the average increase in bottom river temperature was estimated to be of magnitude 0.4 F° (0.2 C°), which was considered not to be a significant impact.

As a result of the 1993 study, the recommended temperature limits for Outfall 101 and Outfall 102 were incorporated in the plant NPDES permit, but were contingent upon verification studies by instream field measurements when the plant begins operation.

1997 Verification Studies of Thermal Discharge for Watts Bar Nuclear Plant

Verification studies of the thermal discharge from Outfall 101 were conducted in 1997, after WBN Unit 1 first began operation (TVA 1998d). The NPDES permit identified three goals of the studies: to determine the three-dimensional configuration of the outfall plumes, to substantiate the dispersion modeling of the thermal effluent, and to assure conformance with the assigned mixing zones. To achieve these goals, two field surveys were performed, one to examine extreme springtime conditions for the maximum river temperature rise and one to examine extreme summer conditions for the maximum river temperature. In both surveys, the measured configuration of the plumes demonstrated that for the conditions tested, the thermal effluent is effectively mixed with the ambient river water. The computed values of the river temperature and river temperature rise at the downstream end of the mixing zone were in good agreement with the measured values, substantiating the method of dispersion modeling. The measurements indicated that the size of the mixing zone (240 feet wide and 240 feet downstream) is sufficient to reduce the temperature of the thermal effluent below the NPDES limits, but recognized that the outfall plume may shift laterally from side to side due to random mixing processes in the river.

No studies were performed for Outfall 102 because there were no occasions where the emergency overflow from the yard holding pond was used. In the years since 1997, there have been occasions to do so. However, on these occasions, the overflow has not been thermally loaded, thus field studies have not been conducted. If and when releases from Outfall 102 occur with one or both WBN units in service, TVA will be responsible for performing thermal surveys of the effluent behavior in the river. As of this writing, such an event has not occurred.

1998 Supplemental Condenser Cooling Water Project Environmental Assessment (EA)

The 1998 EA for the SCCW system (TVA 1998a) included rigorous computer modeling of the WBN heat dissipation system. In this process, the model developed for the discharge temperature limit evaluation of 1993 (TVA 1993b) was expanded to include the SCCW

system servicing Unit 1, as depicted in Section 2.2.2 (Figure 2-2). The primary conclusion from the modeling was that with the SCCW system, Unit 1 could operate in compliance with the river temperature limits for all the NPDES outfalls, 101, 102, and 113. Whereas this is true for normal operating conditions, the 1998 EA recognized that in one situation, exceeding the NPDES limit for the river temperature rate-of-change for Outfall 113 would be unavoidable. This situation includes the unexpected, abrupt loss of heat at Outfall 113 due to a trip of the Unit 1 reactor occurring simultaneously with conditions yielding a river temperature rise near, but yet below, the NPDES limit. Such an event would be extremely infrequent and has not occurred since the startup of the SCCW system in 1999.

The modeling analyses for the 1998 EA were based on the operation of WBN Unit 1 only and again used historical river conditions and historical meteorology for a 17-year period from January 1976 through October 1993. As a result of the analyses, a mixing zone spanning the full width of the river and extending downstream 1000 feet was adopted for Outfall 113. The modeling also indicated that the thermal effluent from Outfall 113 would spread and mix primarily in the upper portion of the water column, protecting bottom habitat and again providing ample space for fish passage in the river. To ensure protection of the bottom habitat, a requirement was provided in the NPDES permit to restrict the maximum river bottom temperature outside a 150-foot square MRZ defined in the immediate vicinity of Outfall 113.

July 1999 Verification Study of Thermal Discharge for Watts Bar Nuclear Plant Supplemental Condenser Cooling Water System

A verification study of the thermal discharge from Outfall 113 was conducted concurrently with the startup of the SCCW system in 1999 (TVA 1999b). The goals of the 1999 verification study were similar to those conducted in 1997: to determine the three-dimensional configuration of the outfall plume, to substantiate the dispersion modeling of the thermal effluent, and to assure conformance with assigned mixing zones. In addition, evaluations also were required to determine the best location for monitoring the upstream ambient river temperature. Moreover, in a manner similar to 1997, data from the 1999 survey demonstrated that for the conditions tested, the thermal effluent from Outfall 113 is effectively mixed with the ambient river water, and that computed values of the river temperature and river temperature rise were in good agreement with the measured values. The measurements indicated that the size of the mixing zone (full width of river and extending 1000 feet downstream) is sufficient to reduce the temperature of the SCCW thermal effluent below the NPDES limits. Temperatures at the boundary of the MRZ also were well below the NPDES limit. Based on the 1999 survey, it was decided to measure the ambient river temperature for Outfall 113 at the discharge of the hydro plant at Watts Bar Dam.

Hydrothermal Data for Watts Bar Nuclear Plant Outfall 113

In addition to the 1999 verification study at startup, five other temperature surveys were conducted for Outfall 113 during the first year of operation of the SCCW system (TVA, 2001). The surveys provided data to better define the configuration of the outfall plume, particularly relative to the effect of water releases from WBH. The surveys were performed for conditions typical of the winter, spring, summer, and fall. The results revealed that for all the conditions, the thermal effluent from Outfall 113 is effectively mixed in the river. Temperatures at the downstream end of the mixing zone were all contained within the NPDES limits and provided ample space for fish passage and protection of bottom habitat. For conditions where no flow is released from WBH, the plume from Outfall 113 tends to

spread across the river and move primarily in the downstream direction. For conditions when there are one or more units in operation at WBH, the plume tends to reside largely in the side of the river containing the SCCW discharge structure (i.e., right side of the river, facing downstream).

**Final Programmatic Environmental Impact Statement –
Tennessee Valley Authority Reservoir Operations Study (ROS)**

In May 2004, the TVA adopted the preferred alternative of the ROS (TVA 2004a). As a part of ROS, rigorous computer modeling of the WBN heat dissipation system was performed to examine the impact of the preferred alternative on water temperatures in the Tennessee River at WBN. The modeling examined the reservoir operating policy of the preferred alternative for an eight-year period spanning 1987 to 1994, which encompassed a broad range of hydrologic conditions in the Tennessee Valley. The studies considered only Unit 1 at WBN, and found that the NPDES water temperature limits could be maintained via appropriate operation of the plant, such as curtailment of the SCCW system. By adopting the preferred alternative, TVA considers any resulting reductions in generation as a necessary and acceptable cost for protecting water quality in the Tennessee River.

**Proposed Modifications to Water Temperature Effluent
Requirements for Watts Bar Nuclear Plant Outfall 113**

To better align the method of monitoring with the behavior of the effluent plume and to alleviate problems related to instream monitoring of the SCCW discharge, TVA proposed in 2004 that the shape of the Outfall 113 mixing zone vary for conditions *with* and *without* flow in the river (TVA 2004d). The modifications were incorporated in the plant NPDES permit, and as of this writing, are still in effect. The mixing zone for conditions *with* flow in the river is identified as the active mixing zone; whereas, that for conditions *without* flow in the river is identified as the passive mixing zone. For cases with flow in the river, tracking of the plume is provided by two instream temperature monitors at the downstream end of the active mixing zone. For cases without flow in the river, biannual instream temperature surveys, one in the summer and one in the winter, are performed to confirm the adequacy of the passive mixing zone and check the accuracy of a hydrothermal model that is used to determine mode of operation of the SCCW system. The configurations of the mixing zones for Outfall 113 are illustrated in Figure 3-2.

Compliance Surveys for Watts Bar Nuclear Plant Outfall 113 Passive Mixing Zone

Beginning in 2005, two compliance surveys have been performed each year, summer and winter, for the Outfall 113 passive mixing zone (TVA 2005e, 2006, 2007b, 2007c). All the surveys have confirmed the adequacy of both the passive mixing zone and the SCCW hydrothermal model.

APPENDIX B – NPDES FLOW DIAGRAM

Page intentionally blank

Abbreviations

- "A" – Alternate Flow Path
- CCW – Condenser Cooling Water
- CRHP – Construction Runoff Holding Pond
- CT – Cooling Tower
- ERCW – Emergency Raw Cooling Water
- HPFP – High Pressure Fire Protection System
- RCW – Raw Cooling Water
- RSW – Raw Service Water
- SCCW – Supplemental CCW
- SGBD – Steam Generator Blow Down
- TC – Training Center
- VW TP – Vendor Water Treatment Plant
- W TP – Water Treatment Plant

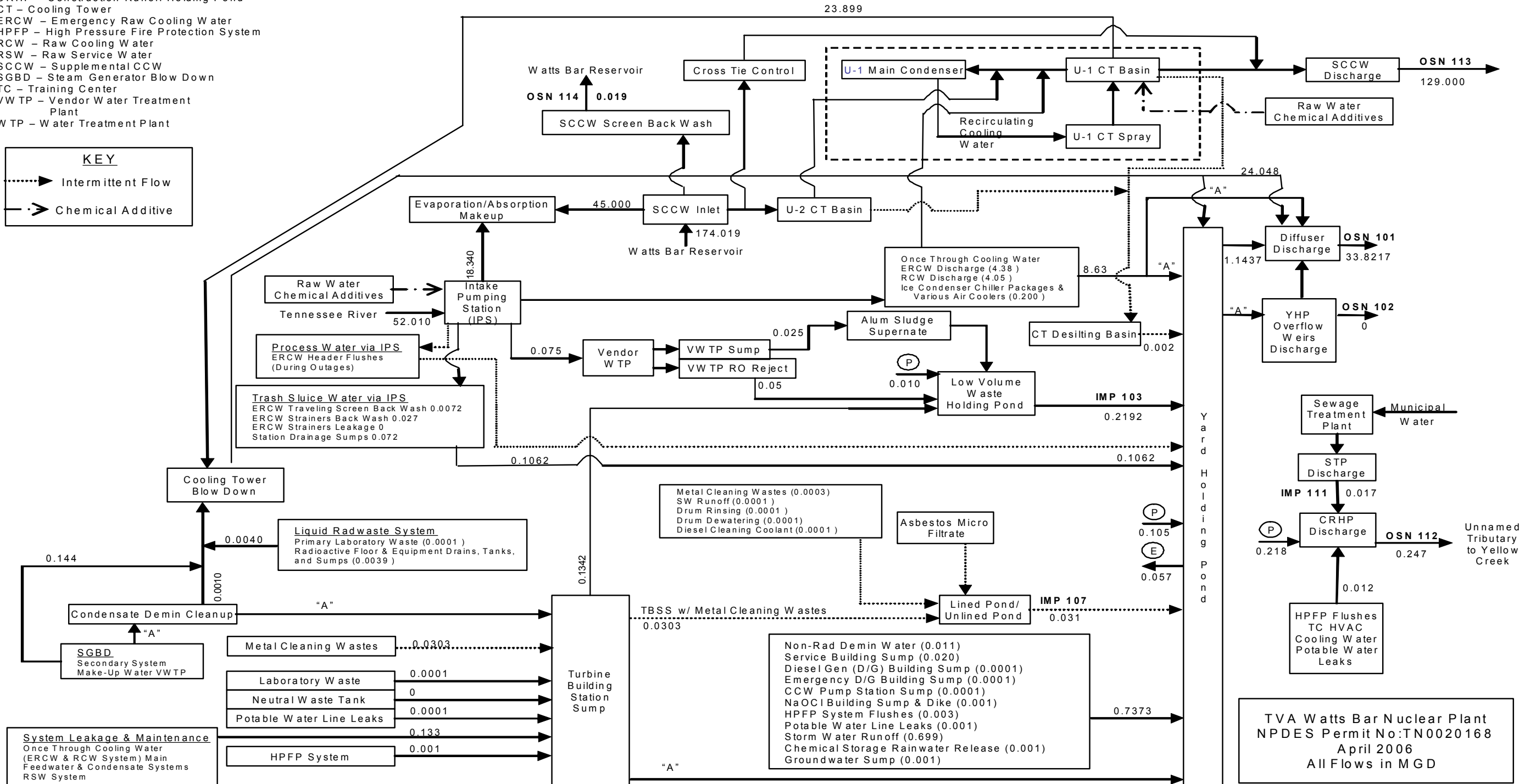
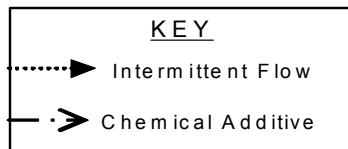

Appendix C – Aquatic Ecology Supporting Information

Page intentionally blank

Table C-1. Total Numbers and Percent Composition of Fish Eggs and Larvae Collected During 1976-1985, 1996, and 1997 in the Vicinity of Watts Bar Nuclear Plant

Taxon	Preoperational											
	1976		1977		1978		1979		1982			
	Total Collected	% Comp	Total Collected	% Comp	Total Collected	% Comp	Total Collected	% Comp	Total Collected	% Comp	Total Collected	% Comp
EGGS												
Unidentifiable fish eggs	5	2.00	40	23.39	722	81.58	4	5.63	8	4.17		
<u>Hiodon</u> spp. eggs	0	0.00	0	0.00	0	0.00	0	0.00	0	0.00		
<u>Aplo</u> dinotus <u>grunniens</u> eggs	245	98.00	131	76.61	162	18.31	67	94.37	184	95.83		
TOTAL	250	100.00	171	100.00	885	100.0	71	100.0	192	100.00		
LARVAE												
Unidentified fish	1	0.01	8	0.02	7	0.19	0	0.00	0	0.00		

Table C-1 (continued)

Clupeidae												
Unspecifiable clupeids	9913	91.17	31679	92.94	1569	42.44	1976	77.04	1259	38.86		
<u>Alosa chrysochloris</u>	0	0.00	6	0.02	0	0.00	0	0.00	0	0.00		0.00
<u>Dorosoma sp.</u>	0	0.00	68	0.20	73	1.97	0	0.00	0	0.00		0.00
<u>Dorosoma cepedianum</u>	2	0.02	637	1.87	334	9.03	0	0.00	324	10.00		
<u>Dorosoma petenense</u>	32	0.29	1	T	0	0.00	0	0.00	20	0.62		
Hiodontidae												
<u>Hiodon tergisus</u>	0	0.00	4	0.01	0	0.00	1	0.04	0	0.00		
Cyprinidae												
Cyprinidae	8*	0.07	14	0.04	28	0.76	5	0.19	5	0.15		
<u>Cyprinus carpio</u>	27	0.25	16	0.05	0	0.00	8	0.31	1	0.03		
<u>Macrhybopsis storeriana**</u>	0	0.00	1	T	0	0.00	0	0.00	0	0.00		
<u>Notropis sp.</u>	0	0.00	1	T	0	0.00	0	0.00	0	0.00		
<u>Notropis atherinoides</u>	0	0.00	4	0.01	5	0.14	0	0.00	0	0.00		

Table C-1 (continued)

Catostomidae												
Unspecifiable catostomids	0	0.00	0	0.00	1	0.03	1	0.04	0	0.00		
<u>Ictiobinae</u>	0	0.00	82	0.24	0	0.00	0	0.00	0	0.00		
<u>Minytrema melanops</u>	2	0.02	1	T	0	0.00	0	0.00	0	0.00		
Ictaluridae												
<u>Ictalurus furcatus</u>	1	0.01	0	0.00	1	0.03	1	0.04	1	0.03		0.03
<u>Ictalurus punctatus</u>	45	0.41	27	0.08	38	1.03	8	0.31	9	0.28		
<u>Pylodictis olivaris</u>	1	0.01	2	0.01	0	0.00	0	0.00	0	0.00		0.00
Percichthyidae												
<u>Morone sp.</u>	1	0.01	62	0.18	73	1.97	13	0.51	16	0.49		
<u>Morone chrysops</u>	0	0.00	0	0.00	1	0.03	0	0.00	0	0.00		
<u>Morone mississippiensis</u>	0	0.00	0	0.00	0	0.00	0	0.00	0	0.00		
<u>Morone (not saxatilis)</u>	5	0.05	50	0.15	7	0.19	31	1.21	199	6.14		

Table C-1 (continued)

Centrarchidae												
<u>Lepomis</u> or <u>pomoxis</u>	0	0.00	0	0.00	0	0.00	0	0.00	0	0.00	0	0.00
<u>Lepomis</u> sp.	209	1.92	428	1.26	873	23.61	57	2.22	857	26.45		
<u>Micropterus</u> <u>dolomieu</u>	0	0.00	0	0.00	0	0.00	0	0.00	1	0.03		
<u>Pomoxis</u> sp.	24	0.22	281	0.82	334	9.03	9	0.35	328	10.12		
<u>Pomoxis</u> <u>annularis</u>	0	0.00	1	T	0	0.00	0	0.00	0	0.00		
Percidae												
Unidentifiable darter	0	0.00	4	0.01	5	0.14	1	0.04	4	0.12		
<u>Perca</u> <u>flavescens</u>	0	0.00	0	0.00	5	0.14	0	0.00	3	0.09		
<u>Stizostedion</u> sp.	1	1.01	5	0.01								
<u>Stizostedion</u> <u>canadense</u>	0	0.00	0	0.00	1	0.03	0	0.00	0	0.00		

Table C-1 (continued)

Sciaenidae										
<u>Aplo</u> <u>dinotus</u> <u>grunniens</u>	601	5.53	704	2.07	310	8.39	454	17.70	205	6.33
Atherinidae										
<u>Labidesthes</u> <u>sicculus</u>	0	0.00	0	0.00	32	0.87	0	0.00	8	0.25
TOTAL	10873	100.00	34086	100.00	3697	100.00	2565	100.00	3240	100.00

Taxon	Preoperational						Operational					
	1983		1984		1985		1986		1987		Total Collected	% Comp
	Total Collected	% Comp	Total Collected	% Comp	Total Collected	% Comp	Total Collected	% Comp				
EGGS												
Unidentifiable fish eggs	1143	87.12	26	27.66	16	51.61	2908	99.28	1591	99.13		
<u>Hiodon</u> spp. eggs	0	0.00	0	0.00	1	3.23	0	0.00	0	0.00		
<u>Aplo</u> <u>dinotus</u> <u>grunniens</u> eggs	169	12.88	68	72.34	14	45.16	21	0.72	14	0.87		
TOTAL	1312	100.00	94	100.00	31	100.00	2929	100.00	1605	100.00		

Table C-1 (continued)

LARVAE										
Unidentified fish	38	0.49	0	0.00	0	0.00	0	0.00	0	0.00
Clupeidae										
Unspecifiable clupeids	5658	73.01	22435	93.33	5890	68.63	4135	83.89	8086	82.08
<u>Alosa chrysochloris</u>	0	0.00	0	0.00	0	0.00	0	0.00	8	0.08
<u>Dorosoma</u> sp.	0	0.00	1	T	0	0.00	0	0.00	0	0.00
<u>Dorosoma cepedianum</u>	1	0.01	114	0.47	0	0.00	74	1.50	1	0.01
<u>Dorosoma petenense</u>	2	0.03	0	0.00	8	0.09	50	1.01	2	0.02
Hiodontidae										
<u>Hiodon tergisus</u>	0	0.00	7	0.03	0	0.00	0	0.00	0	0.00

Table C-1 (continued)

Cyprinidae										
Unspecifiable cyprinids	110	1.42	1*	T	9*	0.10	2	0.04	6	0.06
<u>Cyprinus carpio</u>	15	0.19	7	0.03	0	0.00	2	0.04	2	0.02
<u>Machyropsis storeriana</u> **	0	0.00	0	0.00	0	0.00	0	0.00	0	0.00
<u>Notropis</u> sp.	0	0.00	0	0.00	0	0.00	0	0.00	0	0.00
<u>Notropis atherinoides</u>	0	0.00	0	0.00	0	0.00	0	0.00	0	0.00
<u>Notropis volucellus</u>	0	0.00	0	0.00	0	0.00	0	0.00	2	0.02
Catostomidae										
Unspecifiable catostomids	0	0.00	0	0.00	0	0.00	0	0.00	0	0.00
<u>Ictiobinae</u>	0	0.00	0	0.00	0	0.00	0	0.00	0	0.00
<u>Minytrema melanops</u>	0	0.00	0	0.00	0	0.00	3	0.06	0	0.00
Ictaluridae										
<u>Ictalurus furcatus</u>	0	0.00	0	0.00	0	0.00	0	0.00	0	0.00
<u>Ictalurus punctatus</u>	11	0.14	0	0.00	2	0.02	2	0.04	0	0.00
<u>Pylodictis olivaris</u>	0	0.00	0	0.00	0	0.00	0	0.00	0	0.00

Table C-1 (continued)

Percichthyidae												
<u>Morone</u> sp.	50	0.65	108	0.45	24	0.28	41	0.83	820	8.32		
<u>Morone chrysops</u>	0	0.00	0	0.00	0	0.00	5	0.10	2	0.02		
<u>Morone mississippiensis</u>	0	0.00	0	0.00	0	0.00	16	0.3	6	0.06		
<u>Morone</u> (not <u>saxatilis</u>)	244	3.15	283	1.18	29	0.34	161	3.27	382	3.88		
Centrarchidae												
<u>Lepomis</u> or <u>pomoxis</u>	20	0.26	0	0.00	0	0.00	0	0.00	0	0.00		0.00
<u>Lepomis</u> sp.	309	3.99	247	1.03	2427	28.28	95	1.93	129	1.31		
<u>Micropterus</u> sp.	0	0.00	0	0.00	0	0.00	0	0.00	3	0.03		
<u>Micropterus dolomieu</u>	0	0.00	0	0.00	0	0.00	0	0.00	0	0.00		
<u>Pomoxis</u> sp.	220	2.84	90	0.37	158	1.84	8	0.16	125	1.27		
<u>Pomoxis annularis</u>	0	0.00	0	0.00	0	0.00	0	0.00	0	0.00		

Table C-1 (continued)

Percidae												
Unidentifiable darter	4	0.05	0	0.00	0	0.00	0	0.00	0	0.00	8	0.08
<u>Perca flavescens</u>	12	0.15	9	0.04	9	0.10	6	0.12	0	0.00	0	0.00
<u>Stizostedion sp.</u>	0	0.00	0	0.00	0	0.00	0	0.00	0	0.00	2	0.02
<u>Stizostedion canadense</u>	0	0.00	0	0.00	0	0.00	0	0.00	0	0.00	0	0.00
Sciaenidae												
<u>Aplodinotus grunniens</u>	1056	13.63	737	3.07	25	0.29	324	6.57	267	2.71		
Atherinidae												
<u>Labidesthes sicculus</u>	0	0.00	0	0.00	1	0.01	0	0.00	0	0.00	0	0.00
TOTAL	7750	100.00	24039	100.00	8582	100.00	4929	100.00	9851	100.00	100.00	100.00

T = Less than 0.01 percent composition.
 Preoperational = 1976-1985; Operational = 1996-1997
 * Number collected changed or was previously missing.
 ** Scientific name changed.

Table C-2. Scoring Results for the 12 Metrics and Overall Reservoir Fish Assemblage Index for Chickamauga Reservoir, 2005

Metric	Collection Method	Forebay TRM 472.3		Transition TRM 490.5		Inflow TRM 529.0		Sequoiah TRM 482.0	
		Obs	Score	Obs	Score	Obs	Score	Obs	Score
A. Species richness and composition									
1. Number of species		30	5	30	5	27	3	27	3
2. Number of centrarchid species		7	5	7	5	6	5	7	5
3. Number of benthic invertivores		4	3	4	3	6	3	3	1
4. Number of intolerant species		6	5	7	5	6	5	5	5
5. Percent tolerant individuals	electrofishing	71	0.5	76.2	0.5	58.6	1.0	70.2	0.5
	gill netting	32.2	0.5	23	1.5	0	0	43.4	0.5
6. Percent dominance by one species	electrofishing	42.2	1.5	39.4	1.5	30.5	3	25.1	1.5
	gill netting	30.5	0.5	19.8	1.5	0	0	41	0.5
7. Number nonnative species	electrofishing	0	2.5	0.2	2.5	1	5	0.2	2.5
	gill netting	0.4	2.5	0	2.5	0	0	0	2.5
8. Number of top carnivore species		12	5	9	5	7	5	9	5
B. Trophic composition									
9. Percent top carnivores	electrofishing	6.4	1.5	14.2	2.5	16.7	3	7.3	1.5
	gill netting	51.7	2.5	45.2	1.5	0	0	34	1.5
10. Percent omnivores	electrofishing	11.3	2.5	19.9	2.5	33.3	3	26	1.5
	gill netting	40.5	0.5	37.3	1.5	0	0	58	0.5

Table C-2 (continued)

Metric	Collection Method	Forebay TRM 472.3		Transition TRM 490.5		Inflow TRM 529.0		Sequoayah TRM 482.0		
		Obs	Score	Obs	Score	Obs	Score	Obs	Score	
C. Fish abundance and health										
		11. Average number per run	electrofishing	37.3	0.5	41.8	0.5	67	3	58.5
12. Percent anomalies	gill netting	26.9	2.5	12.6	1.5	0	0	21.5	1.5	
	electrofishing	0.5	2.5	0.8	2.5	2.2	3	0.9	2.5	
	gill netting	0	2.5	0	2.5	0	0	0	2.5	
RFAI		46		48		42		39		
		Good		Good		Good		Fair		

*Percent composition of the most abundant species

Table C-3. Recent (1993-2005) RFAI Scores Developed Using the RFAI Metrics Upstream and Downstream of Watts Bar Nuclear Plant

Station	Location	1993	1994	1995	1996	1997	1998	1999	2000	2001	2002*	2003*	2004	2005	1993-2005 Average
Downstream	TRM 529	52	52	46	--	44	--	42	44	46	48	48	42	42	46
Upstream	TRM 531	43	48		44		41	36	44	39	39	45	43	47	43

Table C-4. Individual Metric Ratings and the Overall Benthic Community Index Scores for Watts Bar Forebay and Sites Downstream of Watts Bar Nuclear Plant, Watts Bar and Chickamauga Reservoirs, November 2005

Metric	TRM 532.5		TRM 527.4		TRM 518	
	Observed	Rating	Observed	Rating	Observed	Rating
1. Average number of taxa	2.9	3	6.8	5	6.4	5
2. Proportion of samples with long-lived organisms	20%	1	100%	5	90%	5
3. Average number of EPT taxa	0.1	1	0.9	5	0.3	1
4. Average proportion of oligochaete individuals	10.2%	5	0.8%	5	1.9%	5
5. Average proportion of total abundance comprised by the two most abundant taxa DOM	95.41%	1	72.01%	5	74.41%	5
6. Average density excluding chironomids and oligochaetes TOTNONCT	21.7	1	480.0	1	610.0	3
7. Zero-samples - proportion of samples containing no organisms	0.1	3	0	5	0	5
Benthic Index Score		15 Poor		31 Excellent		29 Good

TRM 532.5 scored with forebay criteria, TRM 527.4 and 518 scored with inflow criteria.
 Benthic Index Scores: Very Poor 7-12, Poor 13-18, Fair 19-23, Good 24-29, Excellent 30-35
 EPT = Ephemeroptera + Plecoptera + Trichoptera
 DOM = Dissolved Organic Matter
 TOTNONCT = **TOTAL NON-Chironomid Taxa**, i.e., the average number of organisms excluding chironomids and tubificids/sample.

Table C-5. Recent (1994-2005) Benthic Index Scores Collected as Part of the Vital Signs Monitoring Program at Watts Bar Reservoir – Transition and Forebay Zone Sites (Upstream) and Chickamauga Reservoir Inflow (Upstream) and Transition (Downstream) Sites

Site	Reservoir	Location	1994	1995	1996	1997	1998	1999	2000	2001	2002	2003	2004	2005	Average
Upstream	Watts Bar	TRM 532.5	13		11		13		15	13	9	15	17	15	13
Downstream	Chickamauga	TRM 527.4								29	27	33	33	31	30

Table C-6. Sensitive Aquatic Animal Species Known to Occur in the Watts Bar Dam Tailwaters Within 10 Miles of the Watts Bar Nuclear Plant

Common Name	Scientific Name	Status ¹	
		Federal	State
Fish			
Blue Sucker	<i>Cycleptus elongatus</i>	--	THR
Snail Darter	<i>Percina tanasi</i>	THR	THR
Mussels			
Dromedary Pearlymussel	<i>Dromus dromas</i>	END	END (S1)
Pink Mucket	<i>Lampsilis abrupta</i>	END	END
Pyramid Pigtoe	<i>Pleurobema rubrum</i>	--	NOST
Rough Pigtoe	<i>Pleurobema plenum</i>	END	END
Tennessee Clubshell	<i>Pleurobema oviforme</i>	--	NOST
Fanshell	<i>Cyprogenia stegaria</i>	END	END

¹ Status Codes: END = Endangered; NOST = No Status but tracked by the (State) Natural Heritage Project; THR = Threatened.

State Ranking: S1 = Critically Imperiled

Table C-7. Results of Recent Mussel Surveys (1983-1997) Within 2 River Miles Downstream From Watts Bar Dam, Tennessee River Mile 529.9 to 527.9

Common Name	Scientific Name	529.4R* (1990)	529.4L (1990)	527.9- 528.6R (1990)	527.9- 528.6R (1990)	529.0L (1983- 1994)	528.2- 529.0L (1996)	529.2R (1997)	Total
Elephant Ear	<i>Elliptio crassidens</i>	21	2	32	204	2921	268	62	3510
Ohio Pigtoe	<i>Pleurobema cordatum</i>	17	--	4	34	530	47	7	639
Pimpleback	<i>Quadrula pustulosa</i>	1	4	52	4	241	20	10	332
Purple Wartyback	<i>Cyclonaias tuberculata</i>	4	--	8	5	142	13	3	175
Pink Heelsplitter	<i>Potamilus alatus</i>	1	--	6	1	50	4	12	74
Butterfly	<i>Ellipsaria lineolata</i>	--	--	3	--	43	9	2	57
Threehorn wartyback	<i>Obliquaria reflexa</i>	4	1	20	--	7	--	1	33
Pink mucket	<i>Lampsilis abrupta</i>	2	--	--	1	26	1	1	31
Giant Floater	<i>Pyganodon (=anodonta) grandis</i>	--	1	2	--	20	1	3	27
Monkeyface	<i>Quadrula metanevra</i>	1	--	--	--	18	1	3	23
Black Sandshell	<i>Ligumia recta</i>	--	--	1	--	18	1	1	21
Fragile papershell	<i>Leptodea fragilis</i>	--	--	3	2	8	1	2	16
Pistolgrip Pearlymussel	<i>Tritagonia verucosa</i>	--	2	4	--	7	1		14
Pocketbook	<i>Lampsilis ovata</i>	--	--	--	--	8	--	1	9
Mucket	<i>Actinonaias ligamentina</i>	--	--	--	--	--	8		8
Spike	<i>Elliptio dilatata</i>	--	--	1	1	6	--		8

* L = along left descending bank; R = along right descending bank

Table C-7 (continued)

Common Name	Scientific Name	529.4R* (1990)	529.4L (1990)	527.9- 528.6R (1990)	527.9- 528.6R (1990)	527.9- 528.6R (1990)	528.2- 529.0L (1983- 1994)	528.2- 529.0L (1996)	529.2R (1997)	Total
Washboard	<i>Megaloniaias nervosa</i>	--	--	--	--	--	7	--		7
Tennessee Clubshell	<i>Pleurobema oviforme</i>	--	--	--	--	--	6	--		6
Fanshell	<i>Cyrogenia stegaria</i>	--	--	--	--	--	1	--		1
Flat floater	<i>Anodonta sborbiculata</i>	--	--	--	--	--	1	--		1
Fluted Shell	<i>Lasmigona costata</i>	--	--	--	--	--	--	1		1
Kidneyshell	<i>Ptychobranchus fasciolaris</i>	--	--	--	--	--	1	--		1
Longsolid	<i>Fusconaia subrotunda</i> (= <i>maculata</i>)	--	--	--	--	--	1	--		1
Rough Pigtoe	<i>Pleurobema plenum</i>	--	--	--	--	--	1	--		1
White Heelsplitter	<i>Lasmigona complanata</i>	--	--	--	--	--	1	--		1
	Total Specimens	53	14	139	253	4111	253	108		
	Total Species	9	6	13	9	25	9	13		
	Sample Area (square mile)	100	100	250	200	nd**	nd	310		
	Mussels/square mile	0.53	0.14	0.56	1.26	--	--	0.35		

* L = along left descending bank; R = along right descending bank

**nd = not determined (survey conducted using timed intervals, not area)