



EERC

EERC Technology... Putting Research into Practice

Field Testing of Activated Carbon Injection Options for Mercury Control at TXU's Big Brown Station

John Pavlish

Energy & Environmental Research Center

DOE NETL Mercury Control Technology Conference

December 11–13, 2007

Pittsburgh, Pennsylvania

Project Participants



Luminant



Acid Gas Solutions

A Lhoist Group Company



EERC

Energy & Environmental Research Center

Overall Project Objective



Investigate the long-term feasibility of cost-effective mercury removal from Texas lignite–subbituminous blends at TXU's Big Brown Station using activated carbon injection (ACI), with and without additives or enhancements.

- ACI only
- ACI and SEA4
- Enhanced ACI

Big Brown Unit 2 Information

- **600 MW** nominal capacity.
- **Fuel:** typically 70–30 mix of Texas lignite and Powder River Basin (PRB); 100% PRB was also fired.
- **COHPAC™** configuration, high-air-to-cloth baghouse following cold-side electrostatic precipitators (ESPs).



Unit 2 Configuration

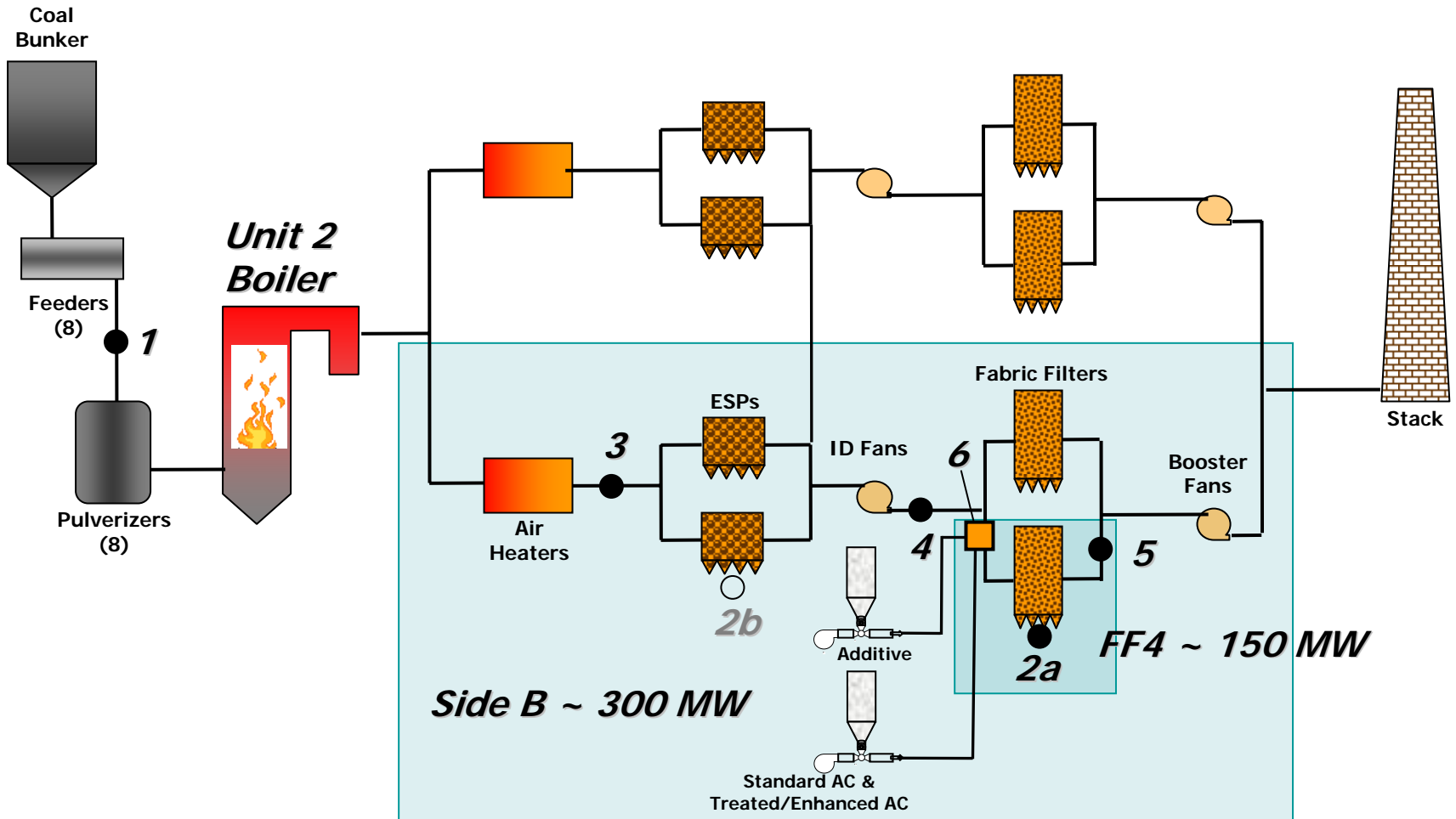

Field Test Summary

Field testing consisted of three phases:

- **Baseline sampling**

- No significant native Hg capture, <5%–10%.

- **Parametric evaluation of sorbent injection options**

- All options achieved greater than the minimum removal target of 55%.

- **One-month evaluation of a single sorbent injection option**

- Enhanced ACI was injected at a rate of 1.5 lb/Macf with an average mercury removal of 74%. BOP issues were observed.

Monthlong Average Compared to Parametric Data, 70–30 Blend

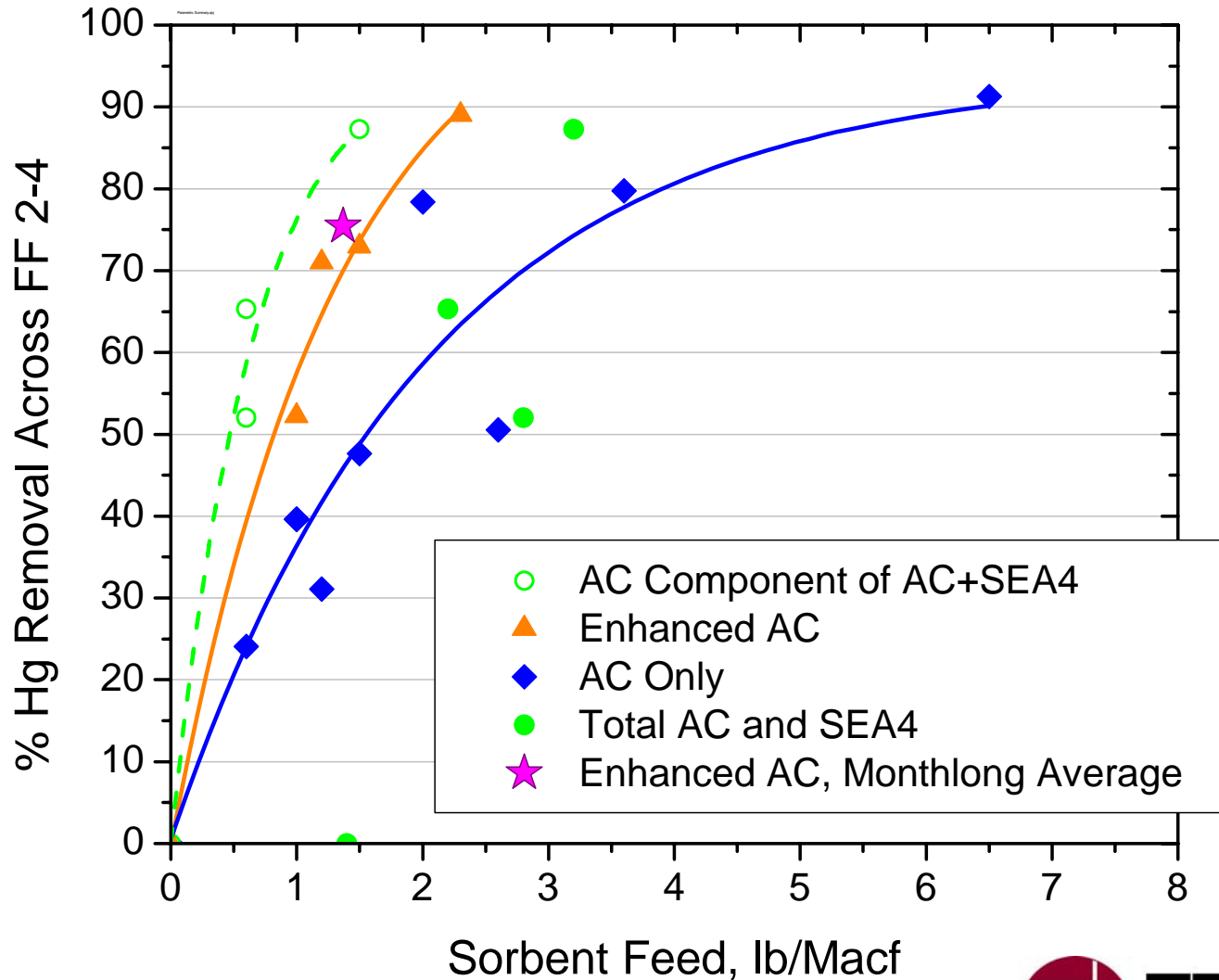

Big Brown Field Testing

Balance-of-Plant (BOP) Issues

- **Bag blinding**—following Hg field testing, the residual drag across FF 2-4 had reached a point where TXU was not confident in its performance for the upcoming summer season; therefore, the plant initiated a full bag replacement of FF 2-4 in May 2006 (approximately 8 months ahead of schedule).
- **Plugged Hoppers/AC Self-Heating**—During the bag change, it was discovered that two of the eight hoppers (Hoppers C and H) on FF 2-4 were plugged and filled with ash. In these two hoppers, unusual deposits were found mixed with the loose ash, which was reported to be very hot and smoldering.
- Further investigations were conducted which included analysis of balance-of-plant issues resulting from the Hg control technology.

Bag Samples Received for Analysis

FF 2-3C
Nov 2005

FF 2-4C
Nov 2005

FF 2-3C
Mar 2006

FF 2-4C
Mar 2006



Carbon Content of Residual Dust

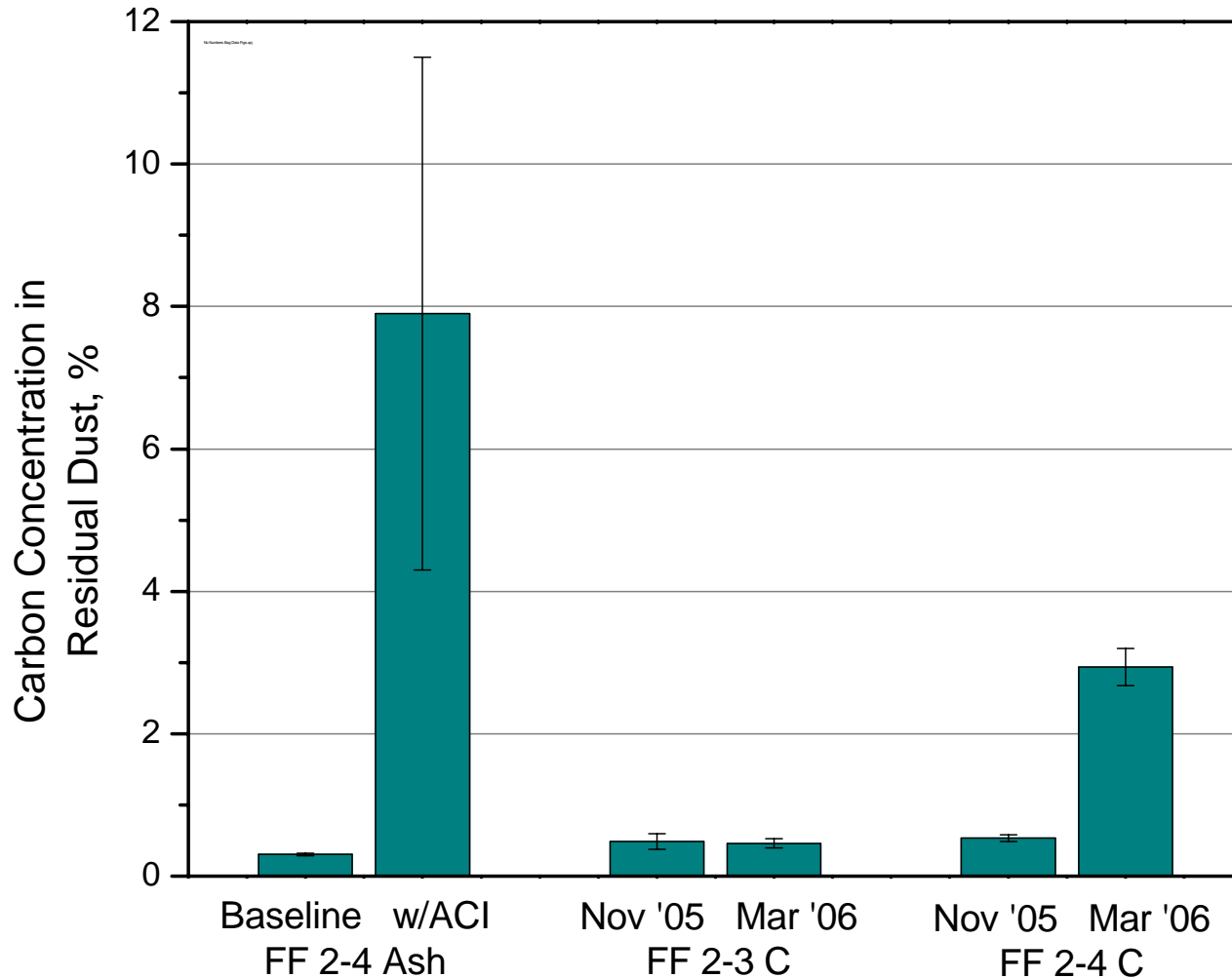

SO₄-NH₃ Accumulation Trend

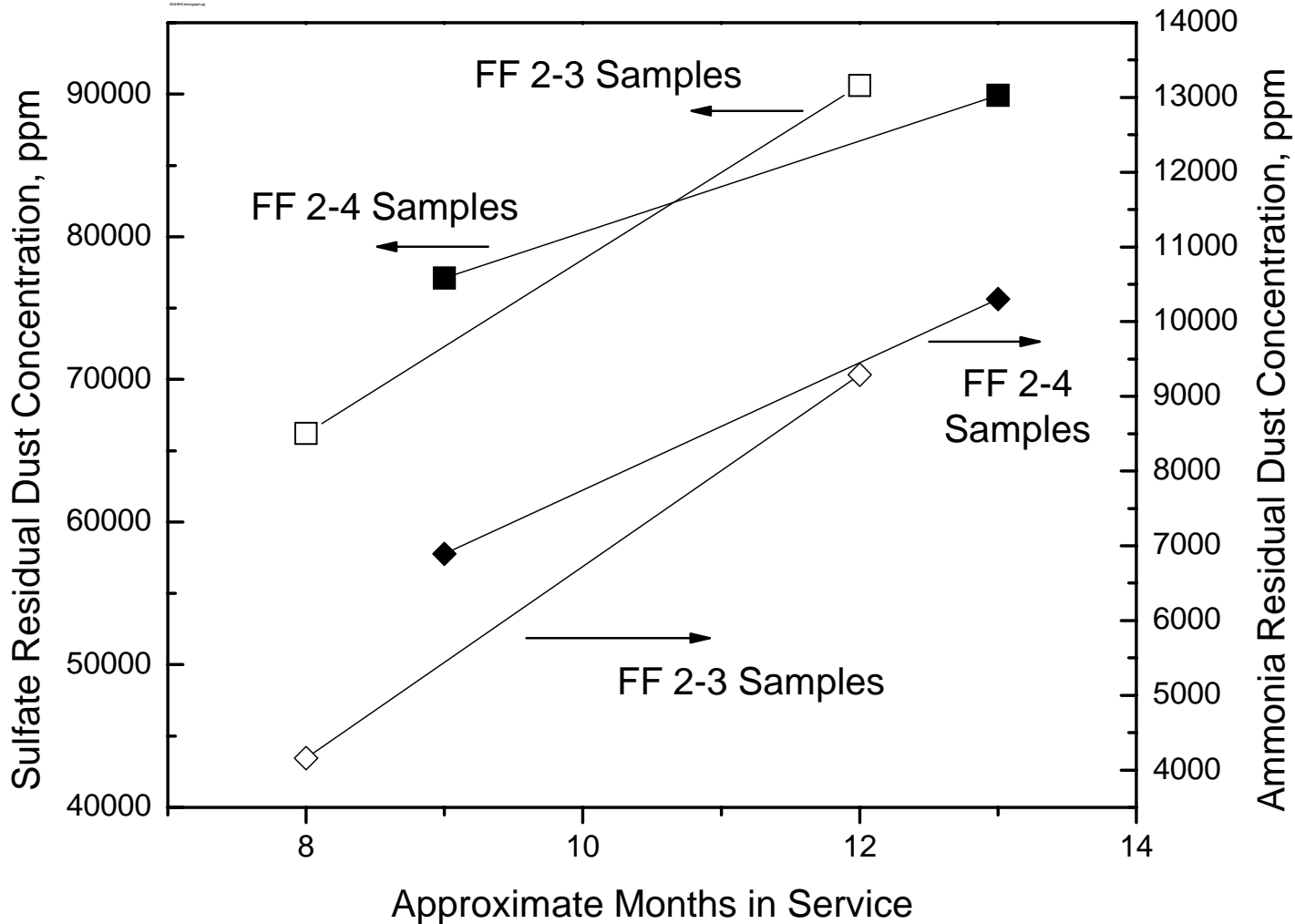

Historic ΔP Trend for 2-3 and 2-4 November 2005 to March 2006

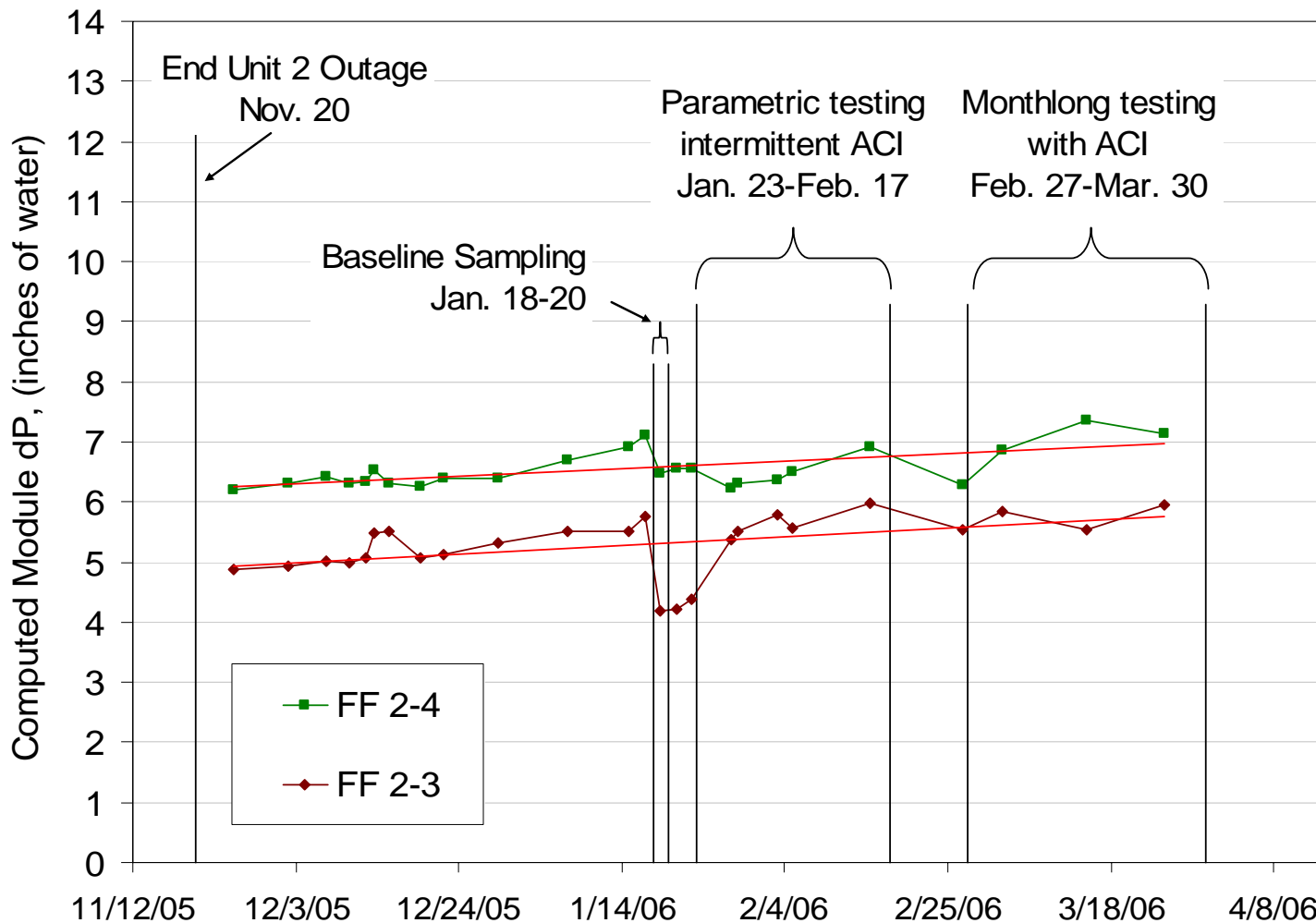

A/C ratio = 11 ft/min

Trends of FF 2-4 ΔP

Air-to-Cloth Ratio, Dust Loading, and AC Content of the Dust

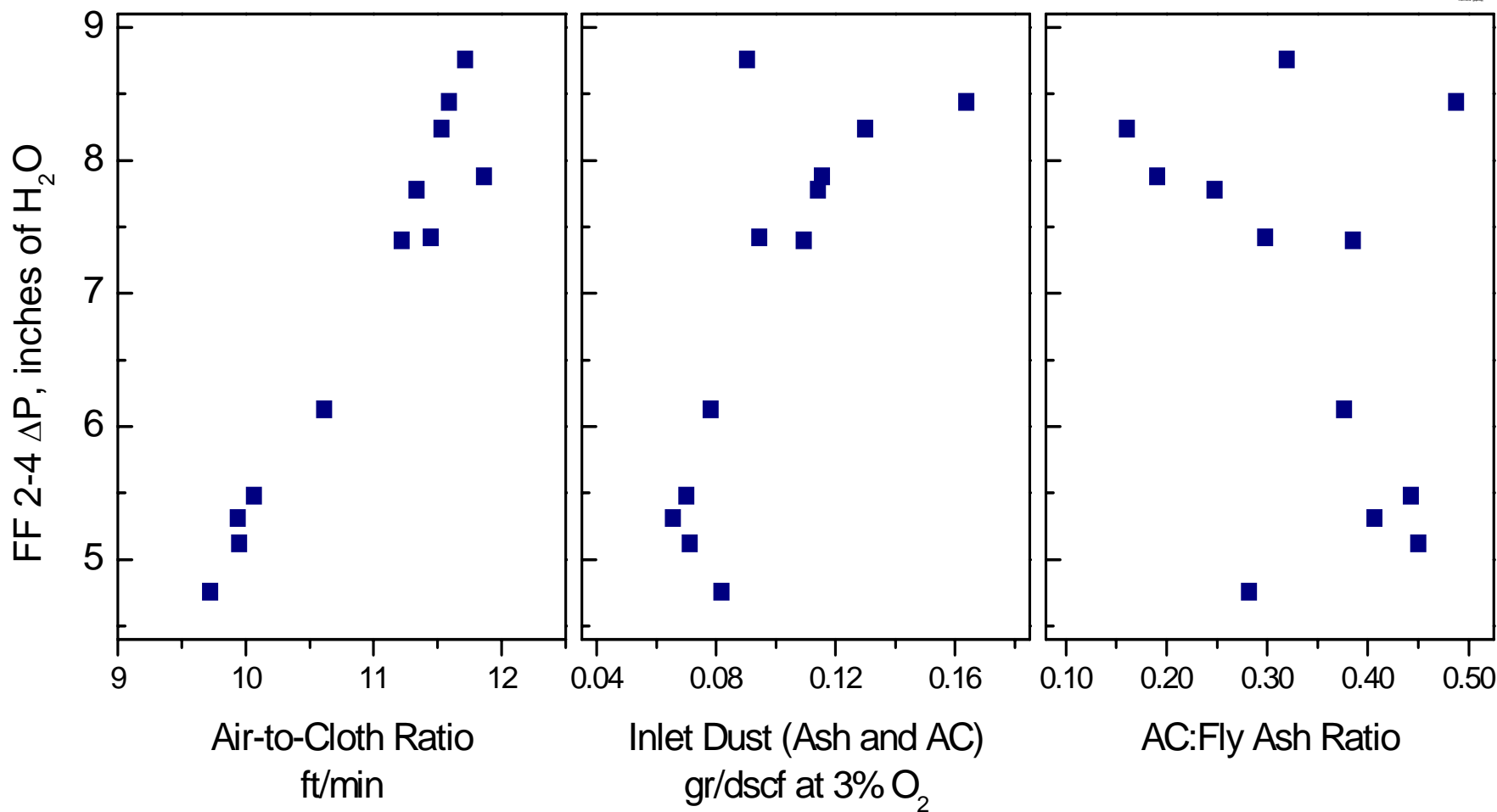

FF 2-4 ΔP Trends Prior to and During ACI

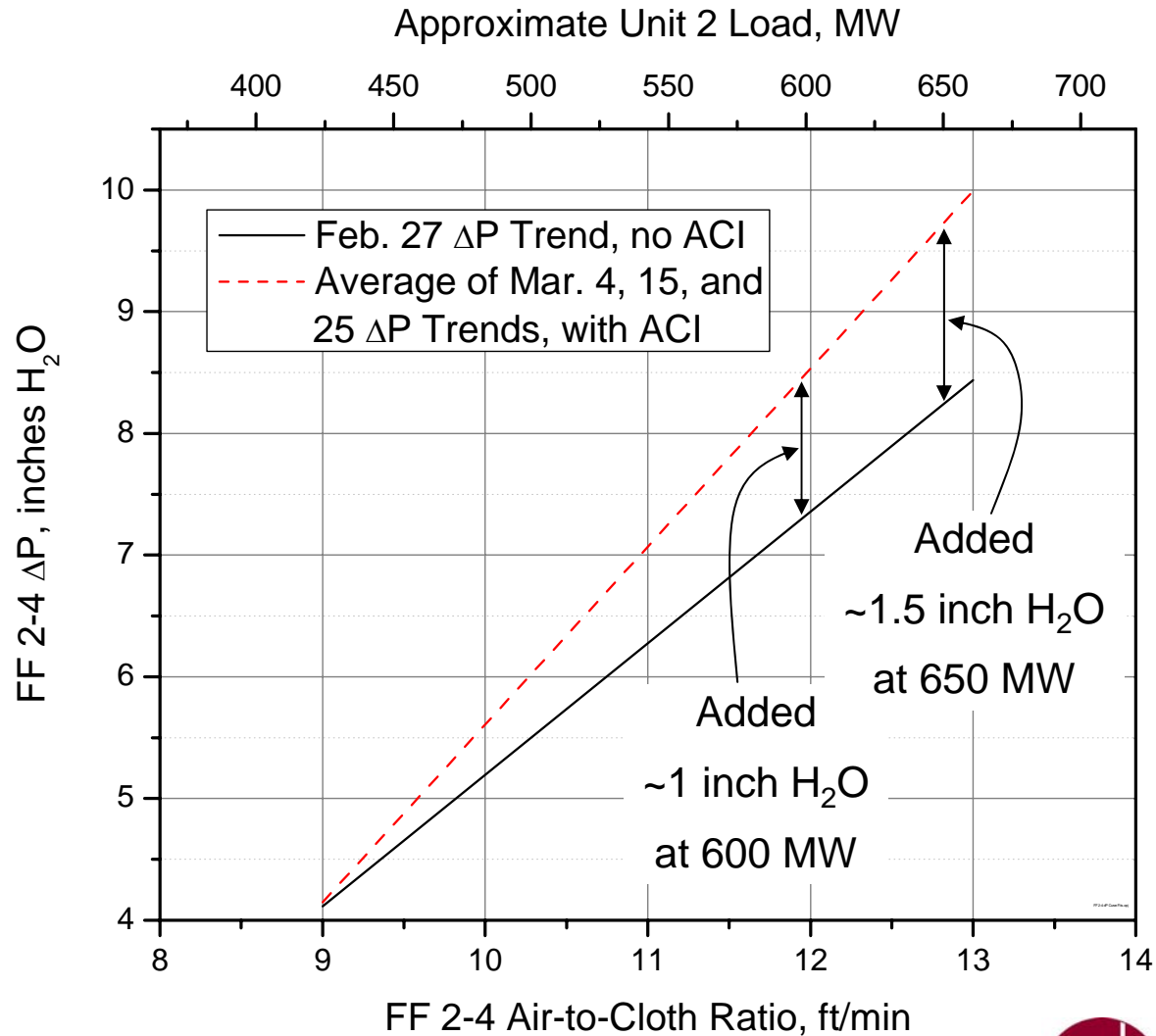

Plugged Hoppers – Ash Level

- When opened for the bag change, both C and H were completely full of ash to a height above the access door.
- The operators did note that ash had collected in the inlet duct and was probably at least to that level and, therefore, completely filling the bottom cone.



Deposits, Hopper C



- According to plant operators, these deposits were extensive. A large mass was centrally located in the bottom cone of the hopper and surrounded completely by ash.
- Ash was hot, burning, and white-gray in color.

Deposits – Hopper H



- Described as having a layering similar to that in Hopper C, with the stronger deposits in the central core and the softer ones above.
- Ash was again very hot/burning and continued to generate heat when dumped from the hopper.

FF 2-4 Hopper Temperature Comparison

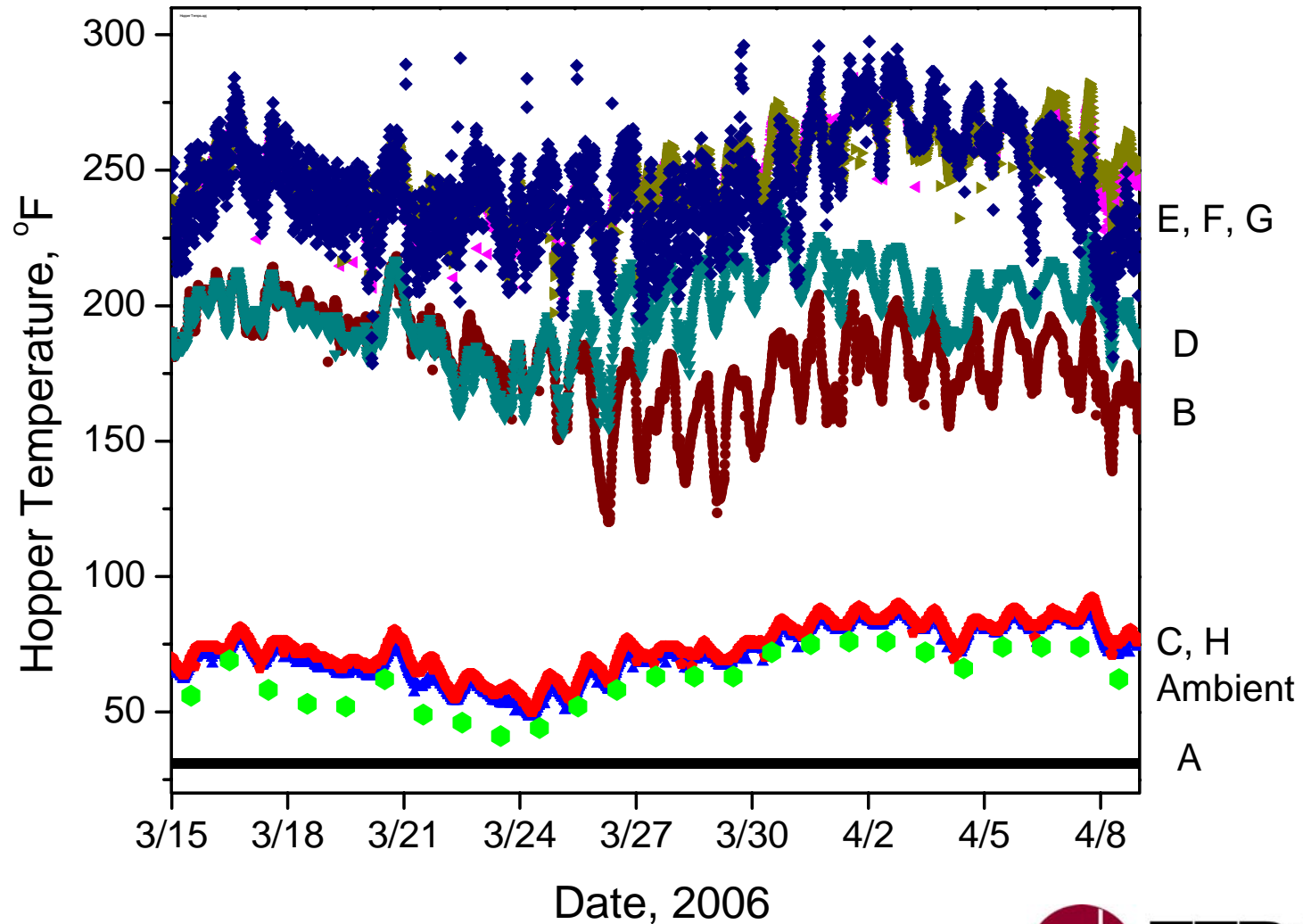

Deposit Analysis

From analysis of the deposits, they can be grouped into two general categories regarding their formation:

- **Molten ash**—The first group appears to have been exposed to extreme heat and comprises the remnants of a molten mixture of ash.
- **Sintered ash agglomerations**—The second group appears to have started as agglomerations of ash, possibly bonded with moisture, that have been “baked” (sintered) to varying degrees.

Self-Heating of Ash-AC Mixtures

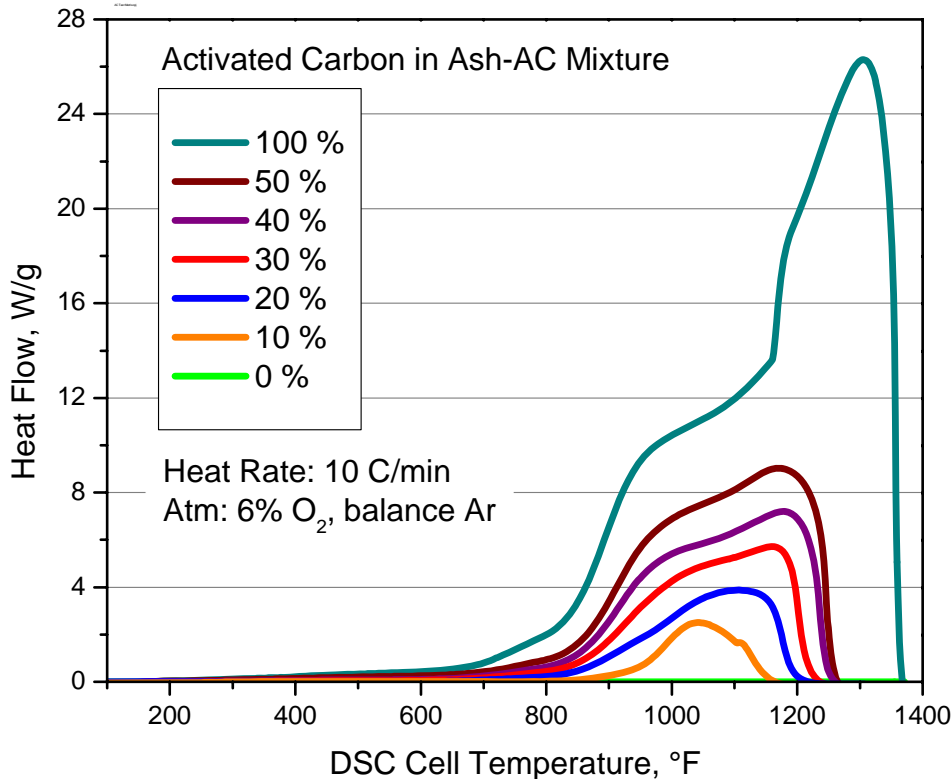

- Thermal analysis of AC-ash mixtures confirms an exothermic heat release at flue gas temperatures.
- In a related CATM[®]-supported effort, a simulation of AC self-heating has been created using these thermal data. The simulation suggests that conditions at Big Brown during the 100% PRB run may have been suitable for self-ignition of the mixture to occur.

Preliminary Estimate of Unstable Ash-AC Mixtures and TOXECON Data Points

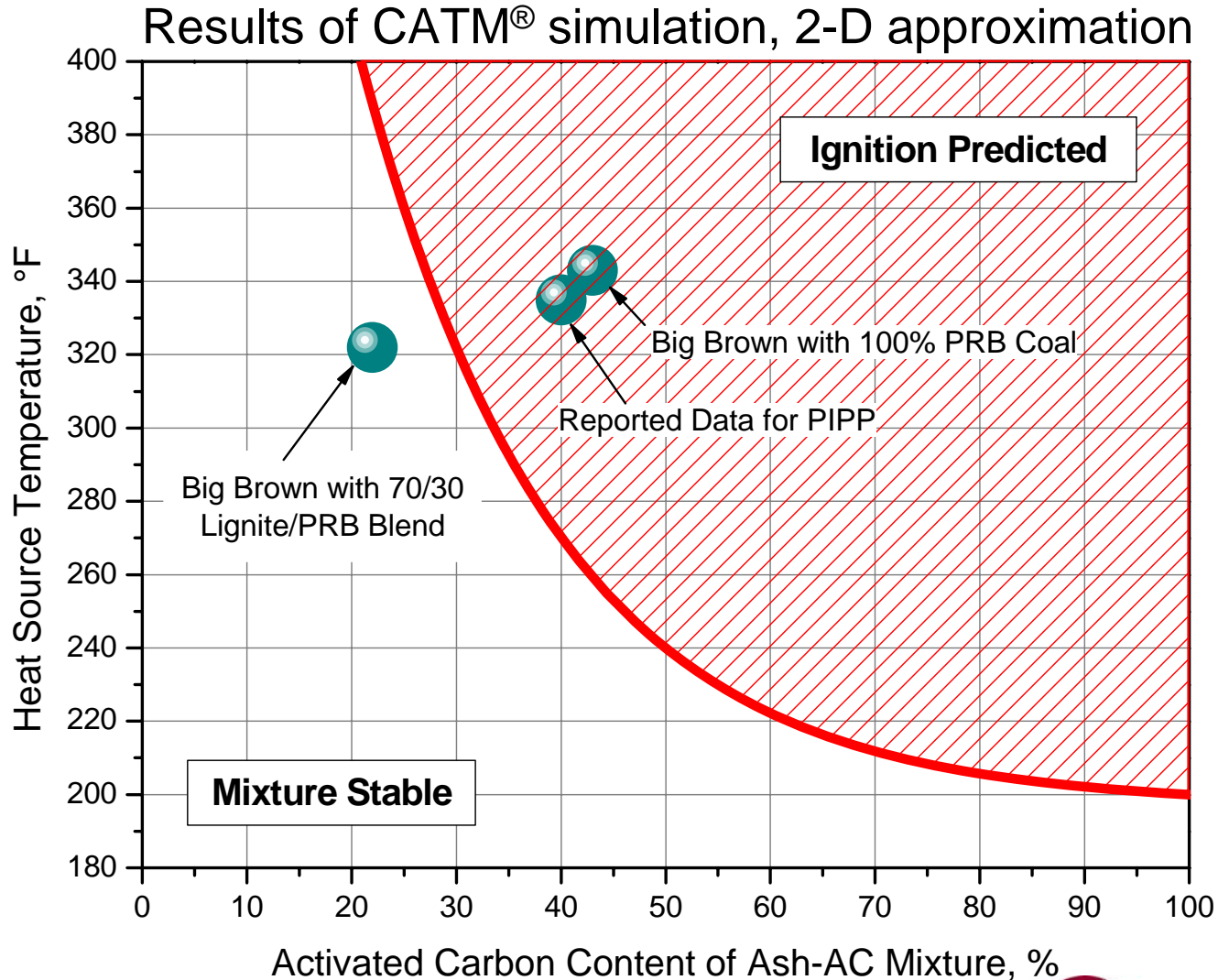

Economic Analysis Scenarios

Estimates of the economics of mercury control at Big Brown were computed for three different scenarios.

Scenario 1: Three sorbent injection options, as tested

- Includes the cost of mercury monitoring
- Balance-of-plant effects (BOP) (ΔP and bag life) not included

Scenario 2: Enhanced ACI option, BOP effects included

- Incremental ΔP increase
- Increased maintenance
- System upgrades to improve reliability and safe operation
 - Improved temperature monitoring, addition of carbon monoxide monitoring, improved hopper fly ash level detection and discharge, and addition of a hopper fire protection system.
- Potential impact on bag life (addressed by sensitivity analysis)

Scenario 3: Scenario 2 with addition of fabric filter capacity

- Evaluate to lower air-to-cloth of 10, 8, and 6 ft/min
- Assumed to lower average ΔP and improve bag life

Comparison of Economic Scenarios

(assumes 90% Hg removal with enhanced ACI)

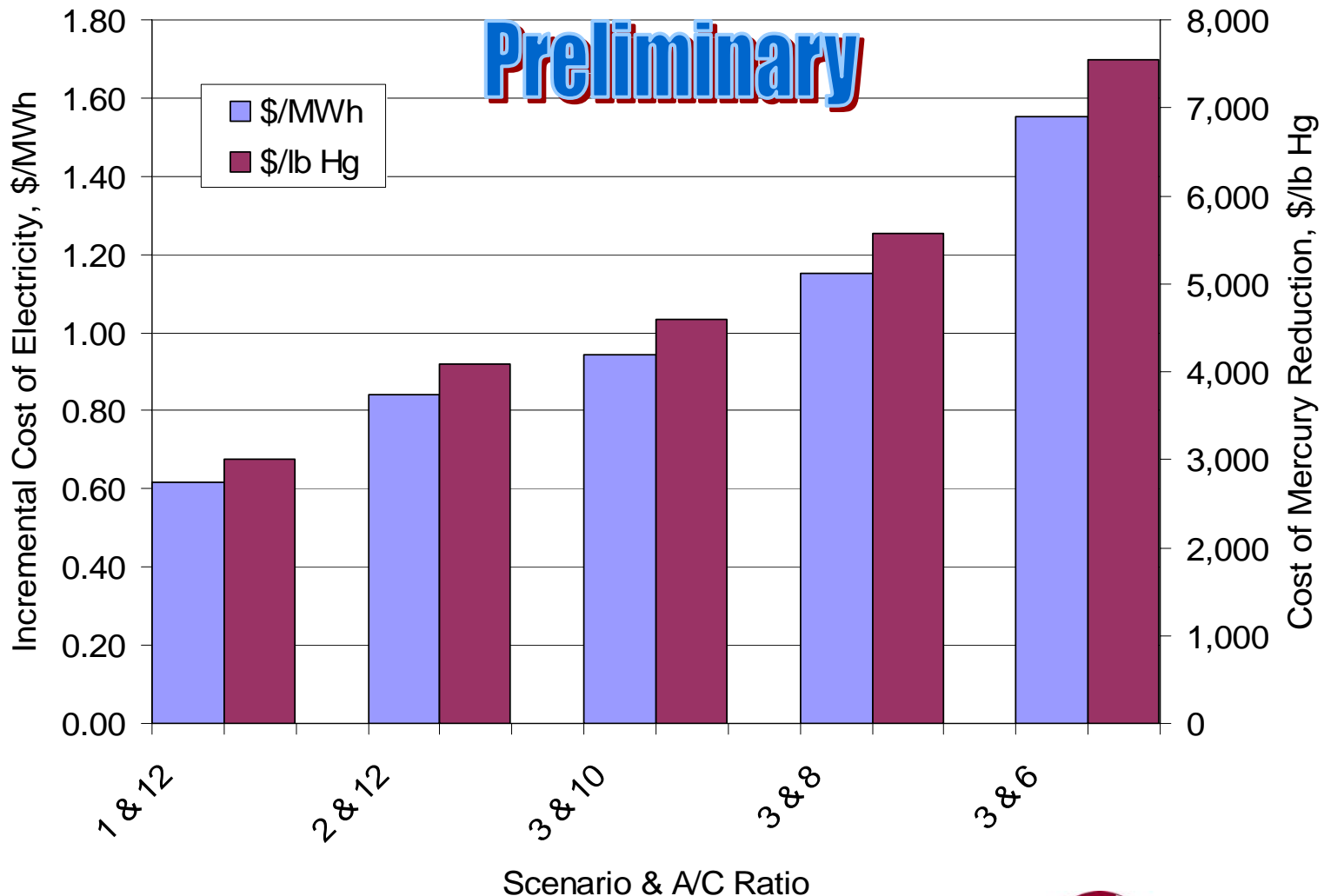

Conclusions

- Mercury removal testing at Big Brown was successful in that significant Hg removal was achieved. All options achieved the minimum targeted value of 55%, and up to 90% removal was possible with increased rates. A removal of 74% was achieved across FF 2-4 during the monthlong test.
- However, because of the limited ΔP margin across the baghouse, ACI in the TOXECON configuration is not sustainable at Big Brown. It is estimated that ACI at the monthlong injection rate (nominally 1.5 lb/Macf) added approximately 1 inch H₂O at 600-MW load to FF 2-4 ΔP . Pressure drop across FF2-4 increased more significantly as the unit operated above 600 MW.
- IF the mercury control could be applied with BOP modifications as described in Scenario 2, the cost would be approximately \$4000/lb-Hg removed (90% removal). By adding additional fabric filter capacity and lowering the A/C ratio to current design levels (6 ft/min), the cost of removal would approximately double.

Conclusions

- Bag blinding was caused by a gradual increase in residual ΔP across the FF bags, resulting from the accumulation of dust on the bags that is not cleaned away by the low-pressure pulse cleaning system. The injected AC did not appear to have significantly affected this rate of residual buildup.
- Essentially no conclusions can be drawn about the effect of ACI on bag life since the duration of testing was limited.
- Malfunctioning instrumentation and equipment led to hopper plugging and storage of stagnant ash-AC mixtures under flue gas conditions during unit operation. This situation eventually led to self-ignition of the ash-AC mixture. In the hoppers that worked properly, no such problems were reported. Therefore, it appears that proper monitoring of ash levels and emptying will be essential to avoid self-heating issues.

Contact Information

Energy & Environmental Research Center

University of North Dakota
15 North 23rd Street, Stop 9018
Grand Forks, North Dakota 58202-9018

World Wide Web: **www.undeerc.org**

Telephone No. (701) 777-5000

Fax No. (701) 777-5181

Project Manager:

John Pavlish

EERC Senior Research Advisor

(701) 777-5268

jpavlish@undeerc.org