

Biomass
**Multi-Year
Program Plan**

March 2008

Office of the Biomass Program
Energy Efficiency and Renewable Energy
U.S. Department of Energy



This page was intentionally left blank

EXECUTIVE SUMMARY

In his 2007 State of the Union address, President Bush challenged the nation to support a goal of reducing gasoline consumption by 20 percent in the next 10 years (“20 in 10”) to “reduce our addiction to oil.” This challenge arises from our continued and growing dependence on imported oil, which exposes the country to critical disruptions in fuel supply, creates economic and social uncertainties for businesses and individuals, and impacts our national security.

Program Goals

The U.S. Department of Energy (DOE) recognizes the importance of a diverse energy portfolio in meeting the nation’s energy security challenges. DOE has, therefore, set a goal in its Strategic Plan to promote energy security through a diverse energy supply that is reliable, clean, and affordable. As a key strategy for attaining both Presidential and Department goals, the DOE Office of Energy Efficiency and Renewable Energy’s (EERE’s) Biomass Program is focused on developing biofuel, bioproduct and biopower technologies in partnership with other government agencies, industry and academia.

The Biomass Program supports four key priorities of the EERE Strategic Plan:

- Dramatically reduce dependence on foreign oil
- Promote the use of diverse, domestic and sustainable energy resources
- Reduce carbon emissions from energy production and consumption
- Establish a domestic bioindustry

Biomass is the single renewable resource that has the potential to supplant our use of liquid transportation fuels now and help create a more stable energy future. Using our indigenous biomass resources, we can potentially fuel our cars and provide new economic opportunities across the nation.

National efforts to meet the President’s goals include the entire biomass-to-biofuels supply chain—from the farmer’s field to the consumer’s vehicle (see Figure A). This Multi-Year RD&D Plan (MYP) details the strategic and performance goals, targets, activities and milestones across the supply chain designed to help achieve the President’s 20 in 10 goal and support EERE’s national priorities for energy.

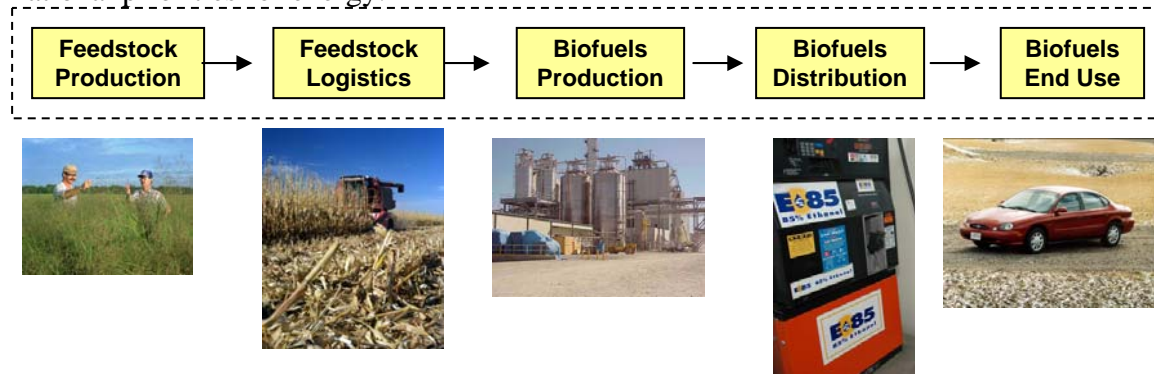

Figure A: Biomass-to-Biofuels Supply Chain

The MYPP also establishes the framework for longer-term goals that will help the nation to achieve sustainable energy security. The Biomass Program vision, mission and strategic goals are in direct alignment with the DOE Strategic Plan and EERE's strategic goals. The overall performance goals set for the Program reflect the current strategy of focusing on cellulosic ethanol as the most immediate path to meeting the President's goals and address both the technology advances required to enable production of cost-competitive cellulosic ethanol and the increase in biofuels production volume needed to meet the petroleum fuel displacement goals. The Program will continue to update its strategy and evaluate the contribution of other biofuels, products and power toward the petroleum displacement goals for future plans. The Program vision, mission and goals are shown below in Figure B.

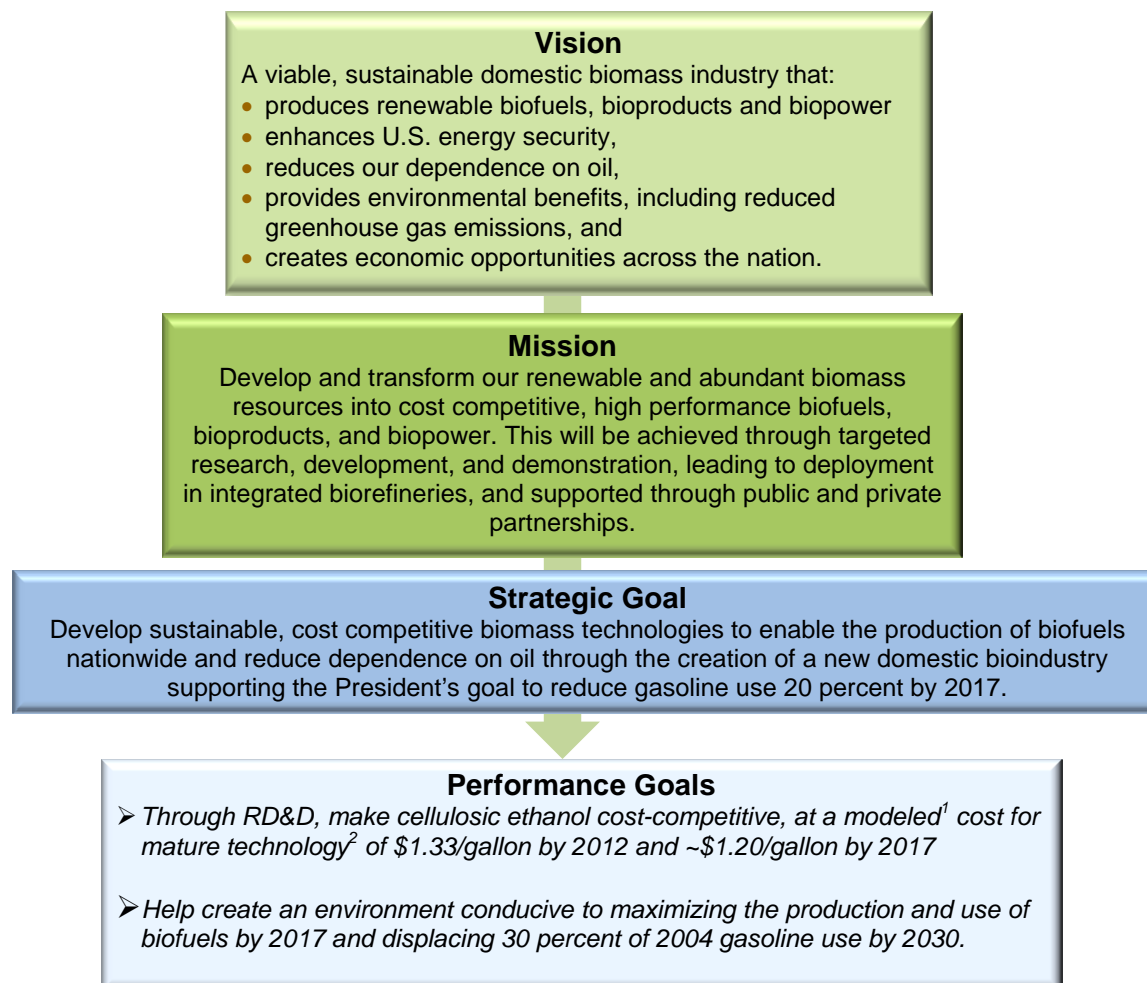

Figure B: Strategic Framework for the Biomass Program

¹ The modeled cost refers to the use of models to project the cost such as those defined in the NREL design reports:

- “Lignocellulosic Biomass to Ethanol Process Design and Economics Utilizing Co-Current Dilute Acid Prehydrolysis and Enzymatic Hydrolysis for Corn Stover,” NREL TP-510-32438, June 2002.
- “Thermochemical Ethanol via Indirect Gasification and Mixed Alcohol Synthesis of Lignocellulosic Biomass,” NREL/TP-510-41168, April 2007.
- Feedstock Logistics Design Report (final editing in progress as of 09/27/07).

² Mature technology processing costs indicate to when several plants have been built and are operating successfully so that additional costs for risk financing, longer startups, under performance, and other costs associated with pioneer plants are not included.

Program Strategy

Meeting the President's goal will require the concerted efforts of federal and state policy and decision-makers, the industrial and agricultural communities, and finance and business entrepreneurs. Coordination of multidisciplinary scientific and engineering expertise of academia and the national laboratories will be critical to building a strong technology foundation. The Biomass Program is accordingly forging new partnerships and strategic alliances to leverage efforts in meeting the technological and economic challenges of establishing integrated biorefineries.

The Biomass Program's work break down structure is organized into three broad categories: core research and development of biomass feedstocks and conversion technologies; industrial-scale demonstration and validation of integrated biorefineries; and crosscutting market transformation activities to accelerate market deployment of cellulosic technologies. Since the wide diversity of biomass feedstocks, conversion technologies, integration options, and potential products together create a multitude of scenarios possible for biorefinery options, the Biomass Program has developed a framework of seven plausible biorefinery pathways that integrate the first three elements of the biomass-to-biofuels supply chain (feedstock production, feedstock logistics and conversion) for specific feedstock classes. This approach streamlines the evaluation of opportunities, establishment of RD&D priorities, and measurement of progress toward commercialization.

A summary of technology development timeline is shown in Figure C, presenting the key activities of the Biomass Program through completion of critical path technology development. The Program is projected to continue beyond this point to support basic science and RD&D on advanced technologies. Detailed analysis of life-cycle costs and benefits, sustainability and environmental impacts, while not specifically detailed as milestones, will continue to inform decisions regarding future biomass activities.

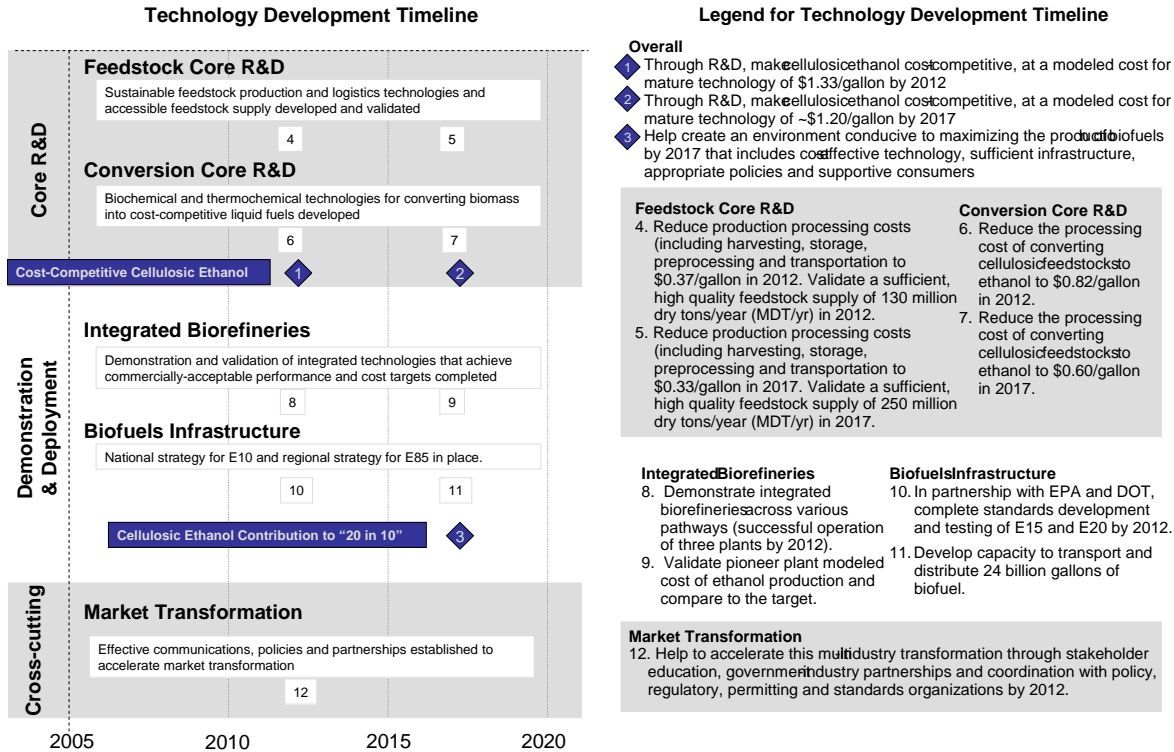

Figure C: Biomass Program Strategy for Technology Development

This approach ensures development of required technological foundation, leaves room for pursuing solutions to technical barriers as they emerge, enables demonstration activities that are critical to proof of performance and lays the groundwork for future commercialization without competing with or duplicating work in the private sector. The plan addresses important technological advances to produce biofuels, as well as the underlying infrastructure needed to ensure that feedstocks are available and the products can be distributed safely with the quality and performance demanded by end consumers.

The Biomass Program’s MYPP is designed to allow the program to progressively enable increasing amounts of biofuels, bioproducts and biopower to be deployed across the nation from a widening array of feedstocks. This approach will not only have a significant impact on oil displacement at the earliest opportunity, but will also facilitate the paradigm shift to renewable, sustainable energy in the long-term.

Contents

Executive Summary	i
Section 1: Program Overview	1-1
1.1 Market Overview and Federal Role of the Program	1-7
1.2 Program Design.....	1-20
1.3 Program Goals, Schedule and Multiyear Targets.....	1-26
Section 2: Program Portfolio Management	2-1
2.1 Program Portfolio Management Process.....	2-1
2.2 Program Analysis	2-6
2.3 Performance Assessment	2-12
Section 3: Technology Research, Development & Deployment Plan.....	3-1
3.1 Feedstocks Platform.....	3-8
3.1.1 Feedstock Support of Biomass Program Strategic Goals.....	3-9
3.1.2 Feedstock Support of Biomass Program Performance Goals.....	3-10
3.1.3 Feedstock Technical Challenges and Barriers.....	3-10
3.1.4 Feedstocks Platform Approach for Overcoming Challenges and Barriers....	3-13
3.1.5 Prioritizing Feedstocks Platform Barriers	3-19
3.1.6 Feedstock Platform Milestones and Decision Points	3-23
3.2 Conversion Platform	3-30
3.2.1 Biochemical Conversion Platform	3-30
3.2.1.1 Biochemical Platform Support of Program Strategic Goals.....	3-32
3.2.1.2 Biochemical Platform Support of Program Performance Goals	3-33
3.2.1.3 Biochemical Platform Technical Challenges and Barriers.....	3-33
3.2.1.4 Biochemical Platform Approach for Overcoming Challenges and Barriers.....	3-35
3.2.1.5 Prioritizing Biochemical Platform Barriers.....	3-41
3.2.1.6 Biochemical Platform Milestones and Decision Points	3-42
3.2.2 Thermochemical Conversion Platform.....	3-47
3.2.2.1 Thermochemical Platform Support of Program Strategic Goals.....	3-50
3.2.2.2 Thermochemical Platform Support of Program Performance Goals.....	3-50
3.2.2.3 Thermochemical Platform Technical Challenges and Barriers	3-51
3.2.2.4 Thermochemical Platform Approach for Overcoming Challenges and Barriers.....	3-52
3.2.2.5 Prioritizing Thermochemical Conversion Platform Barriers.....	3-58
3.2.2.6 Thermochemical Platform Milestones and Decision Points.....	3-59
3.3 Integrated Biorefineries Platform.....	3-65
3.3.1 Integrated Biorefineries Platform Support of Program Strategic Goals.....	3-67
3.3.2 Integrated Biorefineries Platform Support of Program Performance Goals..	3-67
3.3.3 Integrated Biorefineries Challenges and Barriers.....	3-68
3.3.4 Integrated Biorefineries Platform Approach for Overcoming Challenges and Barriers.....	3-70
3.3.5 Prioritizing Integrated Biorefinery Platform Barriers	3-77
3.3.6 Integrated Biorefinery Platform Milestones and Decision Points	3-77

3.4	Biofuels Infrastructure and End Use	3-80
3.4.1	Biofuels Infrastructure Support of Program Strategic Goals.....	3-82
3.4.2	Biofuels Infrastructure Support of Program Performance Goals	3-82
3.4.3	Biofuels Distribution Infrastructure Challenges and Barriers	3-82
3.4.4	Biofuels Infrastructure Approach for Overcoming Challenges and Barriers	3-84
3.4.5	Biofuels Distribution Infrastructure and End Use Milestones and Decision Points	3-85
3.5	Crosscutting Market Transformation Activities.....	3-87
3.5.1	Crosscutting Market Transformation Support of Program Strategic Goals ..	3-88
3.5.2	Crosscutting Market Transformation Support of Program Performance Goals	3-88
3.5.3	Crosscutting Market Transformation Challenges and Barriers	3-89
3.5.4	Crosscutting Market Transformation Approach for Overcoming Challenges and Barriers.....	3-89
3.5.5	Crosscutting Market Transformation Milestones and Decision Points	3-93
Appendix A: OBP Biorefinery Pathways Framework		A-1
Appendix B: Technical Target Tables.....		B-1
Appendix C: Calculation Methodology for Ethanol Cost of Production Targets		C-1
Appendix D: Matrix of Revisions		D-1

BIOMASS PROGRAM VISION AND MISSION



Vision – A viable, sustainable domestic biomass industry that produces renewable biofuels, bioproducts and biopower, enhances U.S. energy security, reduces our dependence on oil, provides environmental benefits including reduced greenhouse gas emissions, and creates economic opportunities across the nation.



Mission – Develop and transform our renewable and abundant biomass resources into cost competitive, high performance biofuels, bioproducts, and biopower. This will be achieved through targeted research, development, and demonstration, leading to deployment in integrated biorefineries, and supported through public and private partnerships.

SECTION 1: PROGRAM OVERVIEW

Growing concerns over climate change and national energy security signal a new urgency for the development of clean biofuels from abundant, domestic biomass. In 2005, President Bush laid

Biomass

Biomass includes agricultural and forestry residues, perennial grasses, woody energy crops, and wastes (municipal solid waste, urban wood waste, and food waste). It is unique among renewable energy resources in that it can be converted to carbon-based fuels and chemicals, in addition to electric power.

out aggressive goals for moving biofuels into the marketplace to reduce the nation's dependence on foreign sources of energy and reduce greenhouse gas emissions from the transportation sector. Specifically, the President's goals are to achieve the following:

- Foster breakthrough technologies needed to make cellulosic ethanol cost competitive with corn-based ethanol by 2012¹
- Increase the supply of renewable fuels to 36 billion gallons by 2022²

Meeting these goals will require significant and rapid advances in biomass feedstock and conversion technologies; availability of large volumes of sustainable biomass feedstock; demonstration and deployment of large-scale, integrated biofuels production facilities; and development of an adequate biofuels infrastructure. In addition, the existing agricultural, forestry, waste management, and automotive industries will need to invest in biomass systems based on economic viability, food security, environmental sustainability, and the needs of the marketplace. These investments will help to shift land use, build capital-intensive biorefineries, and establish the infrastructure and public vehicle fleet required for biofuels distribution and end use.



Ethanol plant under construction in Albert City, Iowa (~100 million gallons of ethanol per year).

The Biomass Program under the DOE Office of Energy Efficiency and Renewable Energy is leading federal efforts to meet these technical and market challenges through the following activities:

- Collaborative R&D to advance feedstock and conversion technologies;
- Public-private partnerships to demonstrate large-scale, integrated biomass technologies and systems; and
- Market transformation activities to accelerate deployment and commercialization of biofuels systems.

¹ Advanced Energy Initiative. (February 2006) The White House National Economic Council
http://www.whitehouse.gov/stateoftheunion/2006/energy/energy_booklet.pdf

² Energy Independence and Security Act, <http://www.whitehouse.gov/news/releases/2007/12/20071219-1.html>; 2007 State of the Union Address, 20 in 10: Strengthening America's Energy Security, <http://www.whitehouse.gov/stateoftheunion/2007/initiatives/energy.html>

Recent national publicity about biofuels as a viable, near-term alternative to conventional transportation fuels places unprecedented pressure on the Biomass Program to produce measurable results.

Scope of Effort/Framework for Success

National efforts to meet the President’s goals include the entire biomass-to-biofuels supply chain—from the farmer’s field to the consumer’s vehicle (see Figure 1-1). This scope represents a significant expansion of the Biomass Program’s historical activities. In the past, the U.S. Department of Agriculture (USDA) took the lead on research, development, and demonstration (RD&D) in feedstock production, while DOE focused on feedstock logistics and cellulosic biomass conversion (through the Biomass Program and Office of Science) and on biofuels distribution and end use (through its FreedomCAR and Vehicle Technologies Program). Contributing to the President’s goals will now require coordination among a broad range of stakeholders across the supply chain.

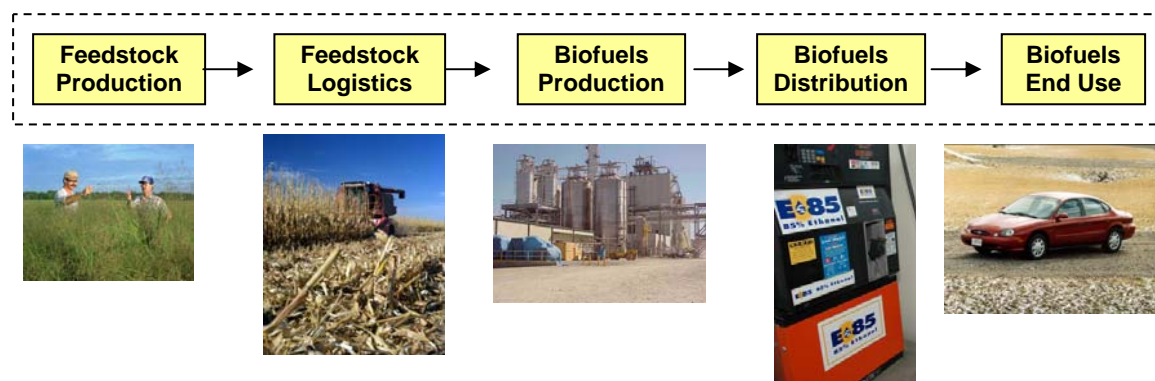

Figure 1-1: Biomass-to-Biofuels Supply Chain

Each element of the supply chain must be engaged to produce the desired set of outcomes, as summarized below:

- **Feedstock Production:** Produce large, sustainable supplies of regionally available biomass.
- **Feedstock Logistics:** Implement cost-effective biomass feedstock infrastructure, equipment, and systems (biomass harvesting, collection, storage, preprocessing and transportation).
- **Biofuels Production:** Deploy cost-effective, integrated, biomass-to-biofuels conversion facilities.
- **Biofuels Distribution:** Implement biofuels distribution infrastructure (storage, blending, transportation (before and after blending), and dispensing).
- **Biofuels End Use:** Expand public availability of biofuels-compatible vehicles offering the same performance as vehicles using traditional fuels.

This supply chain consists of diverse groups of stakeholders who will play a critical role in realizing the President’s challenging biofuels goals. They include members of the general public, scientific/research community, trade and professional associations, environmental organizations, the investment and financial community, existing industries (including the corn ethanol, fuel

distribution, biotechnology, engineering and construction, agriculture, forestry, waste management, and automobile sectors), and government policy and regulating organizations or agencies (federal, state/local, and international). These stakeholders possess valuable insight and perspectives that can help to identify the most critical RD&D challenges and better define optimum strategies for deploying biofuels into the market.

Biomass Program’s Biorefinery Pathways Framework

A critical measure of the Biomass Program’s success is the development, deployment, and market penetration of integrated biorefineries. By producing multiple products, biorefineries can take advantage of the diverse biomass components and processing intermediates to maximize the value and decrease the waste derived from the biomass feedstock.³ However, the wide diversity of biomass feedstocks, conversion technologies, integration options, and potential products together create a multitude of scenarios possible for biorefinery options. As biomass technologies get closer to commercialization, understanding specific biorefinery contexts is critical to successful development and demonstration.

Consequently, the Program developed an approach for defining a family of generic biorefinery pathways that integrate the first three elements of the biomass supply chain (feedstock production, feedstock logistics and conversion) for specific feedstock classes; this approach streamlines the evaluation of opportunities, establishment of research, development, demonstration and deployment (RDD&D) priorities, and measurement of progress toward commercialization. The biorefinery pathways are defined to include technical options to produce a broad slate of fuels, chemicals and materials, heat and power. Figure 1-2 outlines the seven pathways currently under consideration: Corn Wet Mill Improvements, Corn Dry Mill Improvements, Natural Oils Processing, Agricultural Residue Processing, Energy Crops Processing, Forest Resources Processing, and Waste Processing.

Each pathway is linked to a portion of the U.S. biomass resource base identified in the “Billion Ton Study”⁴ and a processing configuration that either exists within the current bio-industry or is envisioned in a future market (see section 3). Appendix A provides detailed flow diagrams and prioritized technical milestones for each pathway. The highest priority pathway milestones provide the basis for the program performance goals.

Biorefinery

A biorefinery is a facility that converts biomass into fuels, power, and chemicals. The biorefinery concept is analogous to today's petroleum refineries, which produce multiple fuels and products from petroleum.

³ (National Renewable Energy Laboratory Website (6-12-07) <http://www.nrel.gov/biomass/biorefinery.html>)

⁴ Biomass as a Feedstock for Bioenergy and Bioproducts Industry: The Technical Feasibility of a Billion-Ton Annual Supply, Robert D. Perlack, et al., USDA/DOE, DOE/GO-102005-2135, April 2005.

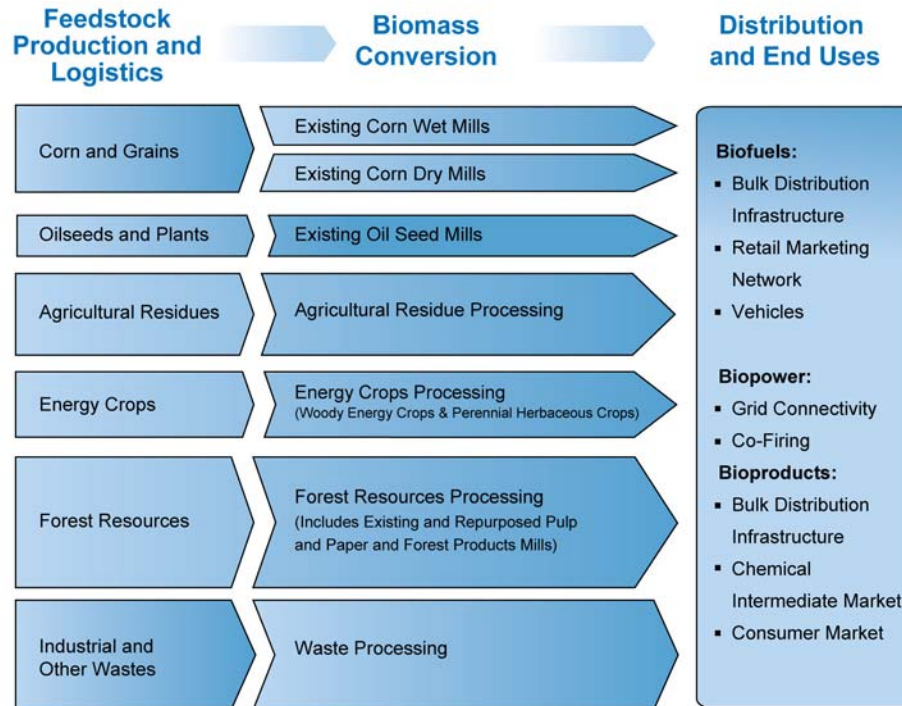

Figure 1-2: Resource-Based Biorefinery Pathway Framework

The pathway approach has several distinct advantages. First, it assures that the Program will examine diverse feedstocks and conversion technologies for producing biofuels, bioproducts and biopower. Second, it effectively links resources with segments of the market, both existing and future. Third, it is adequately flexible to accommodate new ideas and approaches as well as various combinations of pathways or pathway segments in real biorefineries.

Program Focus on Cellulosic Ethanol

Although biorefineries can produce a variety of biofuels, biopower, and bio-based chemicals, the Biomass Program is currently focused on developing, demonstrating, and deploying cellulosic ethanol. The key factor in shaping this focus was the 2012 goal to make cellulosic ethanol cost-competitive with corn-based ethanol; however, more recent national goals require the Program to evaluate and develop other biofuels that could contribute to the Renewable Fuels Standard. Thus, while this plan includes the technical strategy for commercially viable cellulosic ethanol, future Biomass Program plans will expand its focus to other potential biofuels.

The driving factors behind the Program’s current focus on cellulosic ethanol are as follows:

Presidential Initiatives

- The Energy Independence and Security Act (EISA) of 2007 responds to the bold challenge of the President’s "Twenty in Ten" plan. It represents a major step forward in expanding the production of renewable fuels by setting a mandatory Renewable Fuel Standard (RFS) requiring the use of at least 36 billion gallons of biofuel in 2022. Although the President proposed a more ambitious alternative fuels standard in his 2007

State of the Union Address, the RFS in the EISA represents a nearly five-fold increase over current levels.

- In his 2007 State of the Union Address, President Bush challenged the nation to support a goal to reduce gasoline consumption by 20 percent in the next 10 years (20 in 10) to “reduce our addiction to oil.” The President’s 20 in 10 plan calls for an increase in the supply of alternative fuels and more energy-efficient motor vehicles to address energy security and reduce greenhouse gas emissions from motor vehicles and off-road engines and equipment.
- The President’s near-term goal for biomass, as stated in the Advanced Energy Initiative, is “to foster the breakthrough technologies needed to make cellulosic ethanol cost-competitive with corn-based ethanol by 2012, enabling greater use of this alternative fuel to help reduce future U.S. oil consumption.”⁵

Technology Readiness

- Over the last two decades, DOE-funded R&D has led to significant progress in the biochemical processes used to convert cellulosic biomass to ethanol. First-generation technology for cellulosic ethanol production is now in the demonstration phase.
- DOE-funded R&D on alternative transportation fuels and vehicles has led to a well-developed body of work regarding the performance of ethanol as both a low-volume percentage (E10) gasoline blend in conventional vehicles and at higher blends (E85) in flexible-fuel vehicles (FFVs).

Market Acceptance

- Ethanol, from grain-based wet and dry mills, is a well-established commodity fuel with wide market acceptance. Continued success and growth of the ethanol industry can help pave the way for the future introduction of cellulosic ethanol into the marketplace.
- FFV technology is commercially available from a number of U.S. automakers, and several have plans to significantly increase FFV production volumes and expand FFV marketing efforts in the coming years.

Other advanced biofuels, such as biobutanol, hydrocarbons from algae and Fischer-Tropsch gasoline, are still in the early stages of investigation in terms of production technologies, cost-effectiveness, and performance characteristics, while biodiesel from fats or oils via a transesterification process is already commercially viable. As biomass conversion technologies advance and the transportation fuel market evolves, the Program will expand its scope to incorporate additional biofuels that can contribute to the RFS. Efforts to develop these biofuels will be able to build on the technological advances and lessons learned from the cellulosic ethanol RDD&D experience.

⁵ Advanced Energy Initiative. (February 2006) The White House National Economic Council
http://www.whitehouse.gov/stateoftheunion/2006/energy/energy_booklet.pdf

1.1 Market Overview and Federal Role of the Program

Established markets for bioenergy exist today both in the United States and around the world, yet the untapped potential is enormous. Growth of this industry is currently constrained by limited infrastructure, high production costs, competing energy technologies, and other market barriers. Market incentives and legislative mandates are helping to overcome some of these barriers.

1.1.1 Current and Potential Markets

The major end-use markets for biomass-derived products include transportation fuels, products and power. Today biomass is used as a feedstock in all three categories, but the contribution is relatively small compared to oil and other fossil energy forms. Most bio-derived products are now produced in facilities dedicated to a single primary product, e.g., ethanol, biodiesel, plastics, paper, power (corn wet mills are an exception). The primary feedstock sources for these facilities are conventional grains (corn, wheat), oils (including oil seeds like soybeans) and wood. To meet goals for increased production, it will be necessary to use a more diverse feedstock supply that includes cellulosic biomass from agricultural and forest residues and dedicated energy crops. Ultimately the industry is expected to move toward large integrated biorefineries cost-effectively producing biofuels, high-value bioproducts and potentially cogenerating heat and/or power for onsite use.

Transportation Fuels: America's transportation sector relies almost exclusively on refined petroleum products, accounting for over two-thirds of the oil used. With about two-thirds of the transportation fuel used each day in light duty vehicles, over 9 million barrels of oil are required to fuel over 225 million vehicles that constitute the U.S. light-duty transportation fleet. Oil

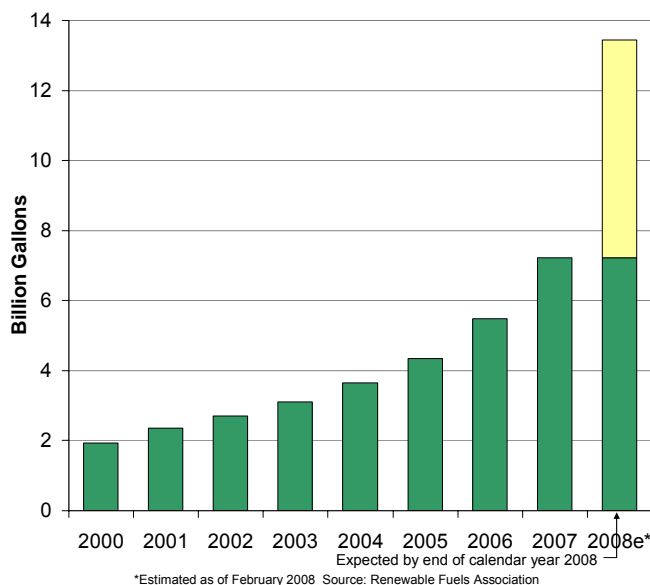

Figure 1-3: U.S. Ethanol Production Capacity

accounts for 97 percent of transportation fuel use with bioenergy, natural gas, and electricity accounting for the remainder. Biomass is a direct, near-term alternative to oil for supplying liquid transportation fuels to the nation. In the U.S., nearly all ethanol is blended into gasoline at up to 10 percent by volume, and cars produced since the late 1970s can run on E10. Automakers also produce a limited number of FlexFuel Vehicles (FFVs) that can run on any blend of gasoline and up to 85 percent ethanol (E85).

High world oil prices, supportive government policies, growing environmental and energy security concerns, and the availability of low-cost corn and soybean feedstocks have provided favorable market conditions for biofuels in recent years. Ethanol, in

particular, has been buoyed by the need to replace the octane and clean-burning properties of MTBE, which has been removed from gasoline because of concerns about groundwater contamination. As a result, demand for fuel ethanol increased by 13.5 percent in 2005 and was

up an additional 29 percent in 2006.⁶ As shown in Figure 1-3, current production of ethanol from grains is nearly 8 billion gallons per year, with annual capacity planned or under construction expected to reach nearly 13 billion gallons by the end of 2008.

The business case for ethanol investment is shaped by fluctuations in prices for two key commodities: gasoline and feedstocks. Commodity prices can fluctuate dramatically, creating market risks for producers and the supply chain. Blender's tax credits for ethanol and biodiesel have helped to ensure biofuels can compete with gasoline. The national RFS legislated by Energy Policy Act of 2005 (EPAct 2005) provides a reliable market for biofuels of at least 7.5 billion gallons by 2012. Historically, when the blender's tax credit is subtracted from wholesale prices, biofuels are price competitive with petroleum fuels on a volumetric basis [EIA AEO 2007]. Figure 1-4 compares the rack price of ethanol (with blender's tax credit) with the price of unleaded gasoline.

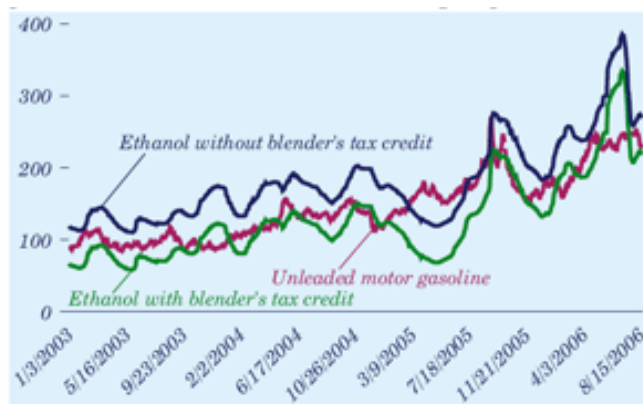

Figure 1-4: Average U.S. Prices for Ethanol and Gasoline, 2003-2006

Profitability in the biofuels industry depends heavily on the cost of feedstocks, which can have a dramatic impact on production costs. The industry assumes considerable market risk when only limited feedstock types are available. The heightened demand for corn – which comprises 70% of the cost of ethanol – has driven the price of that commodity from \$2.32/bu⁷ in 2002 to over \$4.25/bu⁸ 2007. The differential between the cost of the corn feedstock and the open market value of ethanol, known as the crush spread, has declined precipitously. For ethanol producers, this

has put pressure on profit margins and created uncertainty as to the pace of further expansion, particularly once blend mandates currently in force have been met.

The feedstocks used to produce biofuels currently make up only 15 percent of available crop resources and are located at the end of a long agricultural supply chain. The markets for biofuels, biofuel co-products (e.g., animal feed, corn oil and meal), and crop commodities are linked and susceptible to changes in the prices and availability of crops. Surging demand for biofuel feedstocks is likely to continue to exert upward price pressure on corn and soybean commodities and influence export, food, and industrial feedstock markets, particularly in the short term [EIA AEO 2007].

These trends further emphasize the need for production of biofuels from more diverse sources such as cellulosic biomass. To successfully penetrate the market, however, the minimum profitable cellulosic ethanol price must be cost-competitive with corn ethanol and low enough to

⁶ DOE/EIA, October 2006 Monthly Energy Review, Table 2.5 <http://www.eia.doe.gov/emeu/mer/pdf/mer.pdf>

⁷ U.S. Average corn price as reported by the NASS Quick States.

⁸ Price is for open auction corn futures traded on the Chicago Board of Trade.

compete with gasoline. A minimum profitable ethanol selling price of \$2.50/gallon can compete on an energy-adjusted basis with gasoline derived from oil costing \$75-\$80/barrel. At the lower oil prices (\$45 - \$50/bbl) predicted by EIA through 2017 [EIA Annual Energy Outlook 2007], cellulosic technology may not be as competitive and could require policy supports and regulatory mandates to drive the market. The cellulosic ethanol conversion market is currently pre-commercial, with no stand-alone plants in operation. A number of large and small firms, both public and private, are competing to commercialize cellulosic technologies based on a variety of feedstocks.

The current grain ethanol industry, which accounts for most biofuels sales, is comprised generally of smaller firms. The two largest companies, Archer Daniels Midland and Poet, together control about 2.2 billion gallon of current capacity, about 30% of the market. Ten additional companies control the next 30%, and the remainder is comprised of small companies with less than 100 mgy capacity.⁹ Rising costs of feedstock inputs are generally expected to drive consolidation in the industry, favoring firms with strong balance sheets.

The perceived high growth potential of ethanol has benefited ethanol producers as well as other companies which have announced plans to produce ethanol in the future or are related to corn in some way. Farm equipment, seed, agriculture suppliers and rail stocks may be beneficiaries of future increased ethanol and biofuels investment. Ethanol investment has spilled over to corn commodity trading, as some brokers believe that ethanol will help corn futures.

Limited rail and truck capacity has complicated the delivery of ethanol, contributing to regional ethanol supply shortages and price spikes. Feedstock and product transportation costs and concerns remain problematic for the biofuel industry and have led many biofuel producers to explore the prospect of locating near a dedicated feedstock supply or large demand center to minimize transportation costs and susceptibility to bottlenecks.

Retail distribution continues to be an issue as well. Although E10 is readily obtainable across the U.S., there are limited numbers of fueling stations for biodiesel and E85. In 2006, stations equipped for dispensing these fuels only accounted for about 1 percent of fueling stations. Further, some station owners may be averse to carrying B20 or E85, because the unique physical properties of the blends may require costly retrofits to storage and dispensing equipment. Recent EIA estimates for replacing one gasoline dispenser and retrofitting existing equipment to carry E85 at an existing fueling station range from \$22,000 to \$80,000 (2005 dollars), depending on the scale of the retrofit. [EIA AEO 2007]

Independent station owners may also be uncomfortable with novel biofuels and the regulatory environment that surrounds their use and distribution at retail locations. For gasoline outlets operated by major distributors, owners are more likely to be aware of the environmental regulations and more willing to seek appropriate permits when confronted with favorable biofuel economics.

Consumer behavior will play an increasingly important role in determining demand for biofuels. Consumer attitudes about fuel prices, relative fuel performance, biofuel-capable vehicles, and the

⁹ Renewable Fuels Association, Ethanol Biorefinery locations. Viewed 10/4/07 at <http://www.ethanolrfa.org/industry/locations/>

environment will affect the volume and type of biofuels sold. Price, availability, and familiarity are the primary attributes by which many consumers judge the value of biofuels. E85 and B20, for example, are much less common in the United States than are petroleum-rich blends (E10). Consumers who are generally unfamiliar with biofuels have been hesitant to use them, even where they are available.

Products: Approximately 13 percent of the oil consumed in the U.S. is used to make products such as plastics for industrial and consumer goods.¹⁰ Of the 100 million metric tons of chemicals produced annually in the U.S., only 10 percent are biobased.¹¹ U.S. plastics manufacturing, for example, consumes approximately 2 million barrels of oil a day, about 10 percent of the nation's overall consumption, and its products are not biodegradable.¹²

Many products derived from petrochemicals could be replaced with biobased materials. Organic chemicals, such as plastics, solvents and alcohols represent the largest and most direct market for bioproducts.¹³ The market for specialty chemicals is much smaller, but is growing at a rate of 10 to 20 percent annually and offers opportunities for high-value bioproducts.¹⁴ These higher-value products could be used to increase the product slate and subsequently profitability of large integrated biorefineries. The price of bioproducts remains relatively high compared to petroleum-based products largely due to the high cost of converting biomass to chemicals and materials.

With the price of oil reaching record levels, U.S. chemical manufacturers are increasing their exploration into bio-derived plastics and chemicals. Some traditional chemical companies are forming alliances with food processors and other firms to develop new chemical products that are derived from biomass, such as natural plastics, fibers, cosmetics, liquid detergents and a natural replacement for petroleum-based antifreeze.

Co-products of biofuels production, such as corn gluten feed and meal, corn oil, glycerin, and other feed products, also increase with biofuel production. At higher levels of biofuel production in the future, co-products may be oversupplied, resulting in depressed prices for the co-products and lower revenues from their sale to offset fuel production costs. Finding new, high-value uses for co-products could help to ensure that market prices for co-products remain stable. [EIA AEO 2007]

Power: Less than 2 percent of the oil consumed in the U.S. is used for power generation.¹⁵ Fossil fuels dominate U.S. power production and account for about 77 percent of generation, with coal comprising 51 percent, natural gas 16 percent, and oil 3 percent. Biomass accounts for less than 1 percent. New natural gas-fired, combined cycle plants are expected to increase the natural gas contribution to 24 percent by 2025, with coal-fired power maintaining a dominant role (~50 percent). Even so, there are opportunities for biorefineries using cellulosic biomass and

¹⁰ Winning the Oil Endgame: Innovation for Profits, Jobs, and Security, Amory B. Lovins, et al., Rocky Mountain Institute, 2004.

¹¹ Biobased Industrial Products: Research and Commercialization Priorities, NATIONAL ACADEMY PRESS, Washington, D.C. (2000) <http://www.nap.edu/books/0309053927/html>

¹² Site Selection Magazine, Plastics & Chemicals. "Material Facts." July 2007. <http://www.siteselection.com/features/2007/jul/plasticsChemicals/>

¹³ Winning the Oil Endgame: Innovation for Profits, Jobs, and Security, Amory B. Lovins, et al., Rocky Mountain Institute, 2004.

¹⁴ Biobased Industrial Products: Research and Commercialization Priorities, NATIONAL ACADEMY PRESS, Washington, D.C. (2000) <http://www.nap.edu/books/0309053927/html>

¹⁵ EIA Annual Energy Review, 2006 data, <http://www.eia.doe.gov/oiaf/aeo/index.html>

bioconversion routes to use the lignin byproduct for onsite generation of power and/or heat to help meet processing energy demands. Excess electricity produced from cogeneration could be sold back to the local electricity grid.

1.1.2 State, Local, and International Political Climate

State and Local Political Climate

States exercise a critical role in developing energy policies by regulating utility rates and by siting and permitting of energy facilities. Over the last two decades, states have collectively implemented hundreds of policies promoting the adoption of renewable energy. Some of the mechanisms used by states include subsidies, tax credits, rebates, tax incentives, and various other monetary rewards and incentives for producing and using renewable energy. To encourage alternatives to petroleum in the transportation sector, states offer financial incentives for producing alternative fuels, purchasing fuel-flexible vehicles, and developing alternative fuels infrastructure. In some cases, states mandate the use of ethanol and/or biodiesel.

States encourage biomass-based industries as a way to stimulate local economic growth, particularly in rural communities that are facing challenges related to demographic changes, job creation, capital access, infrastructure, land use, and environment. Growth in the ethanol and biodiesel industry creates jobs through plant construction, operation, maintenance, and support. An ethanol facility producing 40 million gallons per year is estimated to expand the local economic base by \$110.2 million each year—through direct spending of \$56 million and \$1.2 million in increased state and local tax receipts.¹⁶ States have also recently begun to develop policies to reduce greenhouse gas emissions and are looking to biomass and biofuels as a way to achieve the targeted reductions.

International Political Climate

Oil is expected to remain the dominant energy source for transportation worldwide through 2030, with consumption expected to increase from 83 million barrels per day in 2004 to 118 million barrels per day in 2030.¹⁷ However, the use of renewable fuels is rising. Many nations are seeking to reduce petroleum imports, boost rural economies, and improve air quality through increased use of biomass. Some countries are pursuing biofuels as a means to reduce greenhouse gas (GHG) emissions in compliance with the Kyoto Protocol. Brazil and the United States lead the world in production of biofuels for transportation, primarily ethanol (see Figure 1-5). Brazil produces ethanol from sugar cane, while most U.S. production comes from corn. There is significant potential for Brazil to export ethanol into the global liquid transportation market if conditions remain favorable and if Brazil can attract sufficient capital to develop its infrastructure. Favorable market conditions include sustained high oil prices and the existence of policy mechanisms such as mandates and tax credits in consuming countries. Brazilian ethanol could meet demand in the U.S., European Union, China, and Japan. Proximity to the U.S. market will reduce transportation cost to the U.S. compared to EU, China, or Japan.

¹⁶ RFA Ethanol Outlook 2005 <http://www.ethanolrfa.org/outlook2005.pdf>

¹⁷ International Energy Outlook 2006, DOE/EIA, [http://www.eia.doe.gov/oiaf/ieo/pdf/0484\(2005\).pdf](http://www.eia.doe.gov/oiaf/ieo/pdf/0484(2005).pdf)

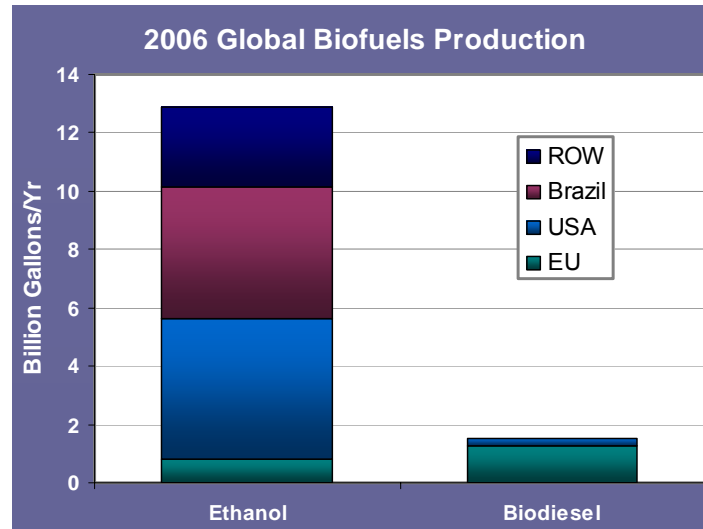

Figure 1-5: Global Production of Biofuels

Today, most biofuels in commercial production in Europe are based on sugar beets, wheat, and rapeseed, which are converted to bioethanol, bio-derived ethyl-tertiary-butyl-ether (ETBE), or biodiesel. In 2003, the European Union (EU) adopted a biofuels directive promoting the substitution of conventional petroleum-based transport fuels with biofuels derived from agricultural crops. The biofuels directive set targets for the biofuel share of all transportation fuels at 2 percent by 2005 and 5.75 percent by 2010.¹⁸ A recent progress report showed that the biofuels share in the EU doubled between 2003 and 2005, reaching 1 percent of consumption. The report also indicates that the EU goal of 5.75 percent may not be attainable by 2010 without expanding the feedstock supply, developing second-generation biofuels (cellulosic), implementing new standards, and increasing the availability of vehicles capable of running on biofuels.¹⁹

Several other countries have developed ethanol programs. China, the third largest producer of ethanol, has selected several provinces to use trial blends of 10-percent ethanol to meet growing demand for gasoline. India, the fourth largest ethanol producer, requires oil companies in some parts of the country to sell gasoline blended with 5-percent ethanol.²⁰ Canada, Thailand, Argentina, and Colombia are also developing regulations to increase ethanol use.²¹

1.1.3 Competing Alternative Fuel Technologies

The principal technologies that compete with biomass today rely on continued use of fossil energy sources to produce transportation fuels, products, and power in conventional petroleum refineries, petrochemical plants, and power plants. In the future, as oil demand and prices

¹⁸ Promoting Biofuels in Europe: Securing a Cleaner Future for Transport, European Commission, Directorate-General for Energy and Transport, 2004 http://europa.eu.int/comm/energy/res/publications/doc/2004_brochure_biofuels_en.pdf

¹⁹ Biofuels Progress Report, Commission of the European Communities COM (2006) 845, 1/10/07. http://eur-lex.europa.eu/LexUriServ/site/en/com/2006/com2006_0845en01.pdf

²⁰ <http://www.planetark.com/dailynewsstory.cfm/newsid/31182/story.htm>

²¹ Homegrown for the Homeland: Ethanol Industry Outlook 2006, Renewable Fuels Association, http://www.ethanolrfa.org/objects/pdf/outlook/outlook_2006.pdf

continue to rise, non-traditional technologies will likely compete with biofuels in meeting some of the transportation fuel needs of the United States. Competing technologies include:

- **Hydrogen:** Hydrogen can be produced via water electrolysis, reforming renewable liquids or natural gas; coal gasification; or nuclear synthesis routes. DOE's Hydrogen Program is currently funding R&D to develop and evaluate these options.
- **Oil Shale-Derived Fuels:** Oil shale is a rock formation that contains large concentrations of combustible organic matter, called kerogen, and can yield significant quantities of shale oil. Various methods of processing oil shale to remove the oil have been developed. DOE's Office of Fossil Energy (FE) has a small program in oil shale focused on reviewing the potential of oil shale as a strategic resource for liquid fuels.
- **Tar Sands-Derived Fuels:** Tar sands (also called oil sands) contain bitumen or other highly viscous forms of petroleum, which is not recoverable by conventional means. The petroleum is obtained either as raw bitumen or as a synthetic crude oil. The United States has significant tar sands resources—about 58.1 billion barrels.²²
- **Coal-to-Liquids:** During the early 1990s, FE funded a number of projects investigating the production of coal-derived liquids under its Clean Coal Technology Demonstration program, and it recently issued a feasibility study for a conceptual coal-to-liquids facility. In terms of cost, coal-derived liquid fuels have traditionally been non-competitive with fuels derived from crude oil. As oil prices continue to rise, however, domestic sources of transportation fuels are becoming more competitive. The report finds promising economic benefits, depending on the price of crude oil. At crude prices of over \$60 per barrel, the commercial-scale coal-to-liquids plant configuration used in the study projects a nearly 20-percent return on investment. FE is also currently sponsoring research on coal-to-hydrogen technologies.²³
- **Electricity:** Electricity can be used to power electric vehicles (EVs). EVs store electricity in an energy storage device, such as a battery. The electricity powers the vehicle's wheels via an electric motor. Plug-in hybrid electric vehicles (PHEVs) combine the benefits of pure electric vehicles and hybrid electric vehicles. Like electric vehicles, they plug into the electric grid and can be powered by the stored electricity alone. Like hybrid electric vehicles, they have engines that enable greater driving range and battery recharging. While factory-made PHEVs are not yet available to the public, EERE's FreedomCAR program is carrying out PHEV R&D²⁴

1.1.4 Market Barriers

Biorefineries using cellulosic biomass as a feedstock face market barriers at the local, state, and federal levels. Production costs, investment risks, cultural perspectives, and infrastructure limitations continue to pose significant challenges for the emerging bioindustry. Widespread deployment of integrated biorefineries will require both demonstration of cost-effective biorefinery systems and establishment of sustainable, cost-effective feedstock supply infrastructures.

²² World Energy Council Survey of Energy Resources 2001

<http://www.worldenergy.org/wec-geis/publications/reports/ser/bitumen/bitumen.asp>

²³ <http://www.fossil.energy.gov/programs/fuels/index.html>

²⁴ http://www.eere.energy.gov/afdc/vehicles/plugin_hybrids_research.html

Cost of Production: An overarching market barrier for biomass technologies is the inability to compete, in most applications, with fossil energy supplies and their established supporting facilities and infrastructure. Uncertainties in fossil energy price and supply continue to exert upward pressure on the price of petroleum-derived fuels and products. Nevertheless, reductions in production costs along the biomass supply chain are needed to make bio-based fuels and products competitive in these markets.

High Risk of Large Capital Investments: Once emerging biomass technologies have been developed and tested, they must be commercially deployed. Financial barriers are the most challenging aspect of technology deployment. Capital costs for commercially viable facilities are relatively high, and securing capital for unproven technology can be extremely difficult. For private investors to confidently finance biomass technology, the technology must be fully demonstrated as technically and commercially viable. Government assistance at the demonstration stage to accelerate proof of performance is critical to successful deployment.

Agricultural Sector-Wide Paradigm Shift: Energy production from biomass on a large scale will require careful evaluation of U.S. agricultural resources and logistics, as these will likely require a series of major system changes that will take time to implement. Current harvesting, storage, and transportation systems are inadequate for processing and distributing biomass on the scale needed to support dramatically larger volumes of biofuels production.

Inadequate Supply Chain Infrastructure: The uncertainty of a sustainable supply chain and the associated risk are major barriers to procuring capital for start-up biorefineries. The lack of operating biorefineries to create the demand for biomass exacerbates the problem. Once demand is established, the infrastructure will grow. Producing and delivering bioenergy products in large volumes will require dramatic capital investments throughout the supply chain—from feedstock production and transport through conversion processing and product delivery.

Lack of Industry Standards and Regulations: The lack of local, state, and federal regulations and inconsistency among existing regulations constrain development of biomass. The long lead times associated with developing and understanding new and revised regulations for technology can delay or stifle commercialization and deployment. Consistent standards are lacking for feedstock supply and infrastructure, as well as for biofuels and the associated distribution infrastructure. Current inconsistencies among federal, state, and local agencies in permitting and regulations for construction of new biofuels production facilities also create a restrictive environment for industry growth.

Industry and Consumer Acceptance and Awareness: To be successful in the marketplace, biomass-derived products must perform as well or better than the fossil-energy-based products. Industry partners and consumers must believe in the quality, value, and safety of biomass-derived products and their benefits.

Lack of Biofuels Distribution Infrastructure: The current lack of infrastructure to transport, store and dispense biofuels puts biofuels at a significant disadvantage compared to conventional liquid transportation fuels that already have mature infrastructure. Today's biofuels distribution

infrastructure, which includes over 1,200 E85 fueling stations, is concentrated in the Midwest, close to the production facilities and feedstocks (corn and soybeans). To contribute significantly to the 20-in-10 volumetric goal, expansion beyond this region of the country will be required.

Availability of Biofuels-Compatible Vehicles: About six million ethanol FFVs have been manufactured for the U.S. market, at a price competitive with conventional vehicles. At this time, however, few vehicle model/fuel type combinations are available. In addition, most FFVs on the road today use less than 4 gallons of E85 per year because of the limited number of E85 pumps across the United States.

Lack of understanding of environmental/ energy tradeoffs: A systematic evaluation of the impact of expanded biofuels production and use on the environment and food supply for humans and animals is lacking. Analytical tools to facilitate consistent evaluation of energy benefit and greenhouse gas emissions impacts of all potential biofuels feedstock and production processes is needed.

1.1.5 History of Public Efforts in Biomass RD&D

Efforts in bioenergy were initiated by the National Science Foundation (NSF) and subsequently transferred to DOE in the late 1970s. Early projects focused on biofuels and biomass energy systems. In 2002, the Biomass Program was formed to consolidate the biofuels, bioproducts, and biopower research efforts across DOE into one comprehensive RD&D effort. From the 1970s to the present, approximately \$2.3 billion has been invested in a variety of RD&D programs covering biofuels (particularly ethanol), biopower, feedstocks, municipal wastes, and a variety of biobased products, including ones from forest products and agricultural processing industries. Key policy shifts, major new legislation, and federal funding levels are shown in Figure 1-6. While steady progress has been achieved in many technical areas, considerably more progress is required before biomass technologies will be broadly competitive in the marketplace.

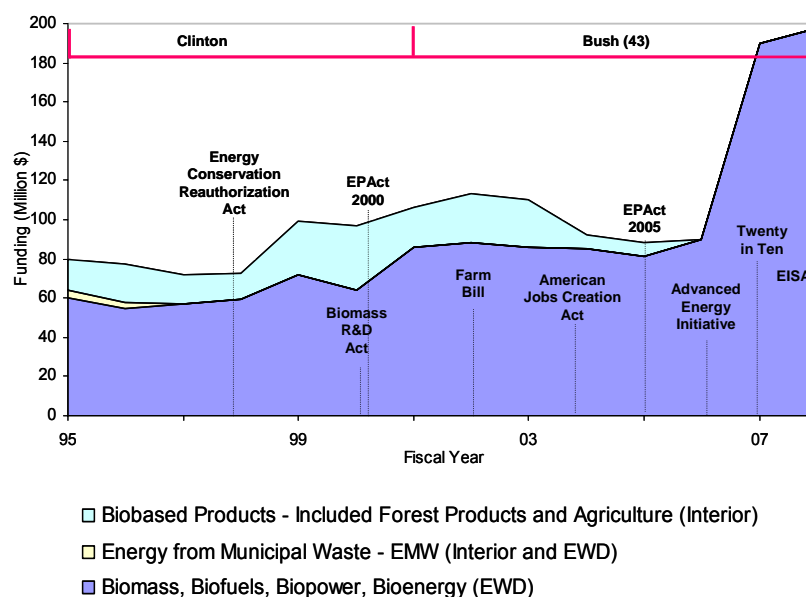

Figure 1-6: Major Policy Shifts, Key Legislation, and Federal Funding Levels for Biomass-Related RD&D, 1995-2007

The current federal and state government policies, regulations, and initiatives that promote biofuels are summarized here.

Federal Executive Branch Actions

Executive Order 13423: In January 2007, President Bush signed Executive Order (E.O.) 13423: “Strengthening Federal Environmental, Energy, and Transportation Management.” This E.O. includes a mandate requiring U.S. agencies with 20 or more vehicles to decrease petroleum consumption by 2% per year relative to their fiscal year 2005 baseline through fiscal year 2015. The order also requires agencies to increase alternative fuel use by 10 percent per year relative to the previous year.

Executive Order 13432: In May 2007, President Bush signed E.O. 13432, “Cooperation Among Agencies in Protecting the Environment with Respect to Greenhouse Gas Emissions from Motor Vehicles, Non-road Vehicles and Nonroad Engines,” which orders the Department of Transportation, the Department of Energy, and the Environmental Protection Agency to coordinate efforts “to protect the environment with respect to greenhouse gas emissions from motor vehicles, non-road vehicles, and non-road engines, in a manner consistent with sound science, analysis of benefits and costs, public safety, and economic growth.”²⁵

“20 in 10” Plan: In the 2007 State of the Union Address, the President recognized our “addiction to oil” and asked that America reduce its gasoline use by 20 percent over the next 10 years (20 in 10).²⁶ A major part of that commitment is to increase the supply of renewable and alternative fuels to 35 billion gallons per year (bgy) by 2017. The remaining 5 percent reduction in gasoline use will be through vehicle efficiency improvements. EISA includes a Renewable Fuels Standard (RFS) requiring 36 bgy of renewable fuel by 2022. The President continues to back this commitment by increasing RD&D funding for the Biomass Program in the Budget Request. DOE, EPA and DOT are evaluating intermediate ethanol blends, e.g. E15 and E20, as a means to displace gasoline while addressing the challenges of building a new biofuels infrastructure in a sustainable manner.

Advanced Energy Initiative (AEI): The AEI proposed in the 2006 State of the Union address calls for measures to reduce our dependence on foreign sources of energy, improve energy efficiency, and enhance energy security.²⁷ Specifically, the President committed to making cellulosic ethanol cost competitive by 2012.

Federal Legislative Branch Actions

Energy Independence and Security Act of 2007: The Energy Independence and Security Act of 2007 (EISA) codifies the President’s “20 in 10” plan with provisions that support the continued development and use of biofuels, including a RFS requiring 36 bgy renewable fuels by

²⁵ [Federal Register: May 16, 2007 (Volume 72, Number 94)] [Presidential Documents] [Page 27715-27719] From the Federal Register Online via GPO Access [wais.access.gpo.gov] [DOCID:fr16my07-138] <http://edocket.access.gpo.gov/2007/07-2462.htm>

²⁶ 2007 State of the Union Address, 20 in 10: Strengthening America’s Energy Security, <http://www.whitehouse.gov/stateoftheunion/2007/initiatives/energy.html>

²⁷ <http://www.whitehouse.gov/stateoftheunion/2006/energy/>

2022 with annual requirements for advanced biofuels, cellulosic biofuels and biobased diesel. See side text box for a description of selected provisions related to biofuels.

EPAct 2005: While federal policies fostering ethanol production have been in place for more than two decades,²⁸ these were renewed and strengthened by the EPAct 2005, which provides incentives for the production and purchase of biobased products.²⁹ These diverse incentives range from authorization for demonstrations to tax credits and loan guarantees (see text box on next page).

American Jobs Creation Act of 2004: The American Jobs Creation Act of 2004 (Public Law 108-357) created tax incentives for biodiesel fuels and extended the tax credit for fuel ethanol. The biodiesel credit was made available to blenders/retailers beginning in January 2005. The Act also established the Volumetric Ethanol Excise Tax Credit (VEETC), which provides ethanol blenders/retailers with \$.51 per pure gallon of ethanol blended or \$.0051 per percentage point of ethanol blended (i.e., E10 is eligible for \$.051/gal; E85 is eligible for \$.4335/gal). This incentive is available until 2010.

2002 Farm Bill: The 2002 Farm Bill promoted development of biobased renewables through federal procurement, grants, and loans for renewable energy projects (Section 9006) and provided R&D funding (Section 9008) as authorized under the Biomass R&D Act of 2000. The Farm Bill is due for re-authorization in 2007 and represents an important opportunity to strengthen the biomass supply chain and ensure the availability of biomass for both first- and second-generation biorefineries. Recommendations for the new Energy Title IX

Energy Independence and Security Act of 2007 Biofuels Provisions

Section 202 establishes an RFS calling for transportation fuel in the U.S. to contain, on an annual average basis, at least the applicable volume of renewable fuel, reaching a total of 36 bgy renewable fuels by 2022.

Section 203 requires a study of the impacts of RFS on each industry relating to production of feed grains, livestock, food, forest products, and energy by June 2009.

Section 207 establishes technology development grants for advanced fuels with 80 percent greenhouse gas reduction from 2008-2015.

Section 209 requires a study to evaluate RFS vehicle emissions impact on air quality including analysis of multiple blend levels, renewable fuel types, and vehicle technologies by June 2009.

Section 223 creates grants for biofuels production R&D in low ethanol-producing states in 2008-2010.

Section 225 requires a study to determine whether optimizing FFVs for E85 would increase fuel efficiency by June 2009.

Section 226 requires a study to determine the effects of engine system performance and durability when using biodiesel and biodiesel blends by December 2010.

Section 231 authorizes additional funding for commercial-scale biorefineries in 2010 (also authorized in EPAct 2005). Section 233 increases the number of Bioenergy Centers to seven.

Section 243 requires a study to assess market, technical, regulatory, financial, and other factors associated with ethanol pipelines by March 2009.

Section 244 creates renewable fuel infrastructure development grants including infrastructure development, technical and marketing assistance, and promoting the construction of refueling infrastructure corridors by December 2009.

Section 245 requires a study of adequacy of existing biofuels infrastructure to transport domestically produced renewable fuels by rail and other modes by June 2008.

Section 246 requires one renewable fuel pump be installed at each Federal refueling center in the US by January 1, 2010.

Section 248 establishes program for RD&D relating to current infrastructure for transportation fuel distribution and new alternative methods.

²⁸ *Biofuels – At What Cost? Government support for ethanol and biodiesel in the United States.* Earth Track, Inc. for Global Subsidies Initiative of the International Institute for Sustainable Development. October 2006. www.globalsubsidies.org

²⁹ Energy Policy Act of 2005. http://frwebgate.access.gpo.gov/cgi-bin/getdoc.cgi?dbname=109_cong_public_laws&docid=f:publ058.109

include an expansion in federal research focused on renewable fuels and bioenergy as well as reauthorization and expansion of existing renewable energy programs. Included are recommendations to fund basic and applied research, as well as loan and loan guarantee programs to help improve the economic, technical, and commercial viability of renewable technologies. Energy Title IX also recommends a new program to provide \$100 million in direct support for producers of cellulosic ethanol, modeled after the Commodity Credit Corporation's (CCC) Bioenergy Program, which expired in 2006.

Sun Grant Research Initiative Act of 2003:

Another example of enabling legislative action is the Sun Grant Research Initiative Act of 2003,³⁰ which was enacted to help solve America's energy needs and revitalize rural communities through land-grant university research, education, and extension programs on biobased energy technologies and products. The Sun Grant Initiative is now a national network of land-grant universities and U.S. DOE laboratories partnering to advance technologies important to bioindustries.

Biomass R&D Act of 2000: In 2000, the Biomass Research and Development Act created the Biomass R&D Initiative

(<http://www.brdisolutions.com/>), a multi-agency effort to coordinate and accelerate all Federal biomass R&D. It also created a Biomass R&D Board and a Biomass R&D Technical Advisory Committee. The Board's role is to coordinate interagency R&D and minimize any duplicative efforts. The Technical Advisory Committee, comprised of industry and academia representatives, ensures that the Federal effort does not duplicate industry's efforts by reviewing the two agencies' annual progress and making recommendations for future activities.

1.1.6 Biomass Program Justification

Over the next 20 years, U.S. energy consumption is projected to rise by 30 percent while domestic energy production increases by 25 percent, intensifying the potential for energy imports. Petroleum imports now serve for more than 55 percent of U.S. energy needs and that

Energy Policy Act of 2005 Selected Provisions

Section 932 d authorizes funds for biorefinery demonstrations that will help to reduce the risk of private investment through validation of technology performance.

Section 941 expands the Biomass R&D Act of 2000, increases authorization, and includes grants to state research agencies.

Section 942 authorizes incentives (e.g., reverse auction) to ensure annual production of one billion gallons of cellulosic biofuels by 2015.

Section 1341 provides tax credit for purchasers of new alternative fuel vehicles.

Section 1342 provides 30% tax credit for installation of alternative fuel stations.

Section 1344 extends the tax credit of \$0.51 per gallon of ethanol, \$1.00 per gallon of agri-biodiesel, and \$.50 per gallon of waste-grease biodiesel through 2008.

Section 1345-1347 creates production incentives for small ethanol producers (\$0.10 per gallon on the first 5 million gallons).

Section 1501 creates a renewable fuel phase-in (ethanol or biodiesel) with mandated 7.5 billion gallons by 2012; provides renewable fuel credit trading to ensure optimal economic/geographic use; and provides for 250 million gallons of cellulosic ethanol in the fuel mix.

Title 17 authorizes loan guarantees for projects that avoid or reduce greenhouse gases and employ new or significantly improved technologies compared to commercial technologies now in use; renewable energy systems such as biofuels are included.

³⁰ <http://www.sungrant.org/authorization.cfm>

share could increase to more than 68 percent by 2025.³¹ This increased reliance on imported energy threatens our national security, economic health, and future global competitiveness. In addition, the U.S. transportation sector is responsible for one-third of our country's carbon dioxide (CO₂) emissions, the principal greenhouse gas contributing to global warming.

Combustion of biofuels also releases some CO₂, but because biofuels are made from plants that just recently captured that CO₂ from the atmosphere, rather than billions of years ago, that release is largely balanced by CO₂ uptake for the plants' growth. Depending upon how much fossil energy is used to grow and process the biomass feedstock, use of biofuels can substantially reduce net greenhouse gas emissions. Biomass is the only renewable energy resource that can be converted to liquid transportation fuels, and according to the Pew Center on Global Climate Change³², increased use of renewable fuels such as ethanol provides the best option for reducing GHG emissions from the transportation sector.

The overarching federal role is to ensure the availability of a reliable, affordable, and environmentally sound domestic energy supply. Billions of dollars have been spent over the last century to construct the nation's energy infrastructure for fossil fuels. The production of alternative transportation fuels from new primary energy supplies, like biomass, is no small undertaking. The federal role is to invest in the high-risk, high-value biomass technology RDD&D that is critical to the nation's future, but that industry would not pursue independently. States, associations, and industry will be key participants in deploying biomass technologies once risks have been sufficiently reduced by federal programs.

³¹ US Department of Energy, Energy Information Agency, Annual Energy Outlook 2006, With Projections to 2030 (February 2006) DOE/EIA 0383-2006

³² <http://www.pewclimate.org/global-warming-basics>, accessed

1.2 Program Design

1.2.1 Program Structure

The Biomass Program’s work breakdown structure is organized around three broad categories of effort: core R&D, demonstration and deployment, and crosscutting activities for market transformation. The first two categories are comprised of four technical elements: Feedstock R&D, Conversion R&D, Integrated Biorefineries, and Biofuels Infrastructure (Figure 1-7).

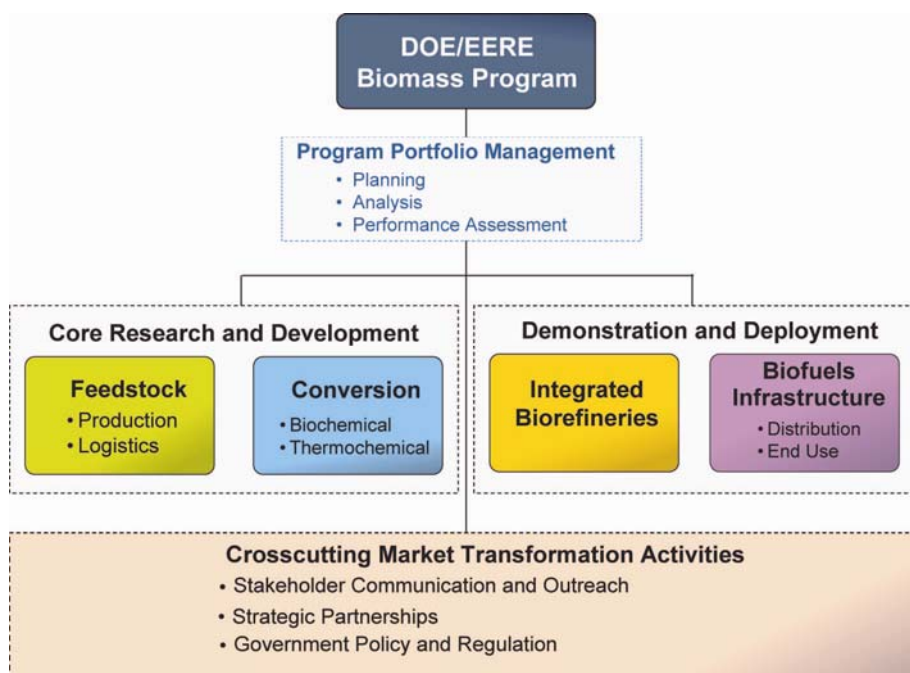

Figure 1-7: Elements of the Biomass Program

This approach provides for the development of pre-commercial, enabling technology as well as the integration and demonstration activities critical to proof of performance. It also accommodates the market transformation activities needed to help the Program overcome market barriers and accelerate deployment.

Core Research and Development: Core R&D activities on feedstock production, logistics, and biomass conversion technologies are building the scientific and technical foundations for the new bioindustry. The Program is looking to advance science in these areas through important collaborations with the DOE Office of Science Bioenergy Centers and USDA. R&D is also directed to address technical challenges and improve the operation of integrated biorefinery demonstrations as needed. The Program has developed Regional Feedstock Partnerships to begin to realize the resource potential outlined in the “Billion Ton Study.”³³ This approach facilitates collaboration by industry, the agricultural community, state and local governments, and USDA and is expected to accelerate resource readiness as the cellulosic fuels industry emerges.

³³ Biomass as a Feedstock for Bioenergy and Bioproducts Industry: The Technical Feasibility of a Billion-Ton Annual Supply, Robert D. Perlack, et al., USDA/DOE, DOE/GO-102005-2135, April 2005.

Demonstration and Deployment: Government cost sharing of pilot-scale, demonstration-scale, and pioneering commercial-scale integrated biorefineries is needed to reduce investment risks and provide the reliability and performance data required to foster rapid commercialization. The Biomass Program has increased its emphasis on industrial-scale demonstration and validation of cellulosic technologies to help “buy down” risk and accelerate deployment. The Program is also working to address the critical challenges associated with establishing an infrastructure capable of handling dramatically increased volumes of biofuels.

Crosscutting Market Transformation: The Biomass Program recently created a new program element to overcome the non-technical market barriers that could slow or even prevent full market penetration of biomass technologies. The Program is developing a sophisticated understanding of market issues to improve the development and implementation of market transformation activities. These activities include stakeholder communications and outreach, strategic partnerships, and government policies and regulations.

1.2.2 Program Logic

The Program logic diagram shown in Figure 1-8 identifies inputs that guide the Program strategy and external factors that require continuous monitoring to determine the need for any programmatic adjustments. The diagram shows Program activities and their outputs, leading to outcomes that support the Program mission and vision. This progression of linkages provides a framework for the Program strategy and this multiyear plan.

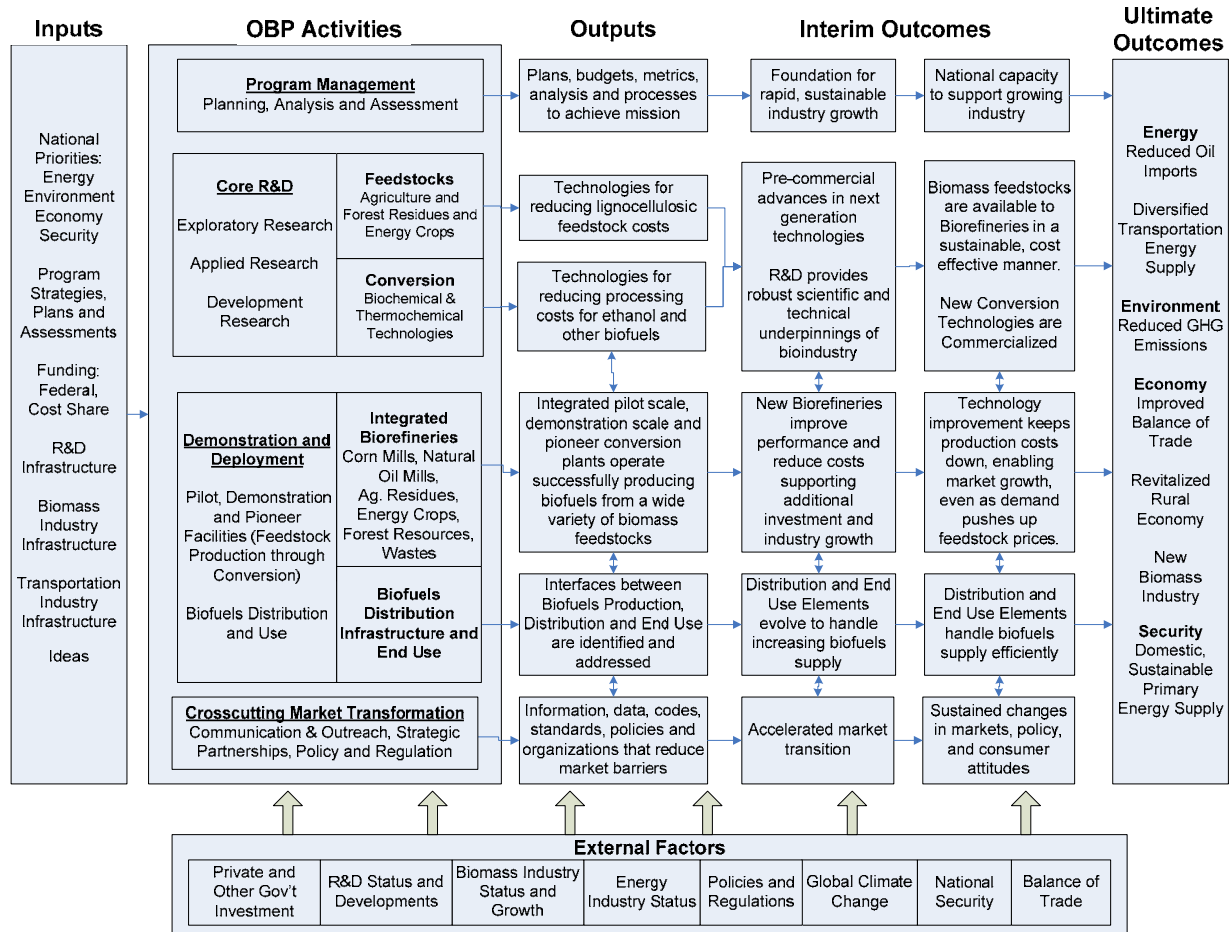

Figure 1-8: Biomass Program Logic Diagram

1.2.3 Coordination of Federal Activities

Coordination with other government offices involved in bioenergy is essential to avoid duplication, leverage limited resources, optimize the federal investment, ensure a consistent message to all of its stakeholders, and meet the national energy goals. The Biomass Program ensures coordination with programs within DOE and with other federal agencies through the Biomass Research and Development Board and Biomass R&D Technical Advisory Committee.

Biomass R&D Board: The Biomass R&D Act of 2000 authorized the creation of the Biomass R&D Board, which coordinates R&D across federal agencies to promote the use of biobased fuels and products, maximize benefits from federal grants and assistance, and bring coherence to federal strategic planning. Co-chaired by DOE and USDA, the Board is comprised of senior-level representatives from the Environmental Protection Agency; the National Science Foundation; the Departments of Interior, Commerce, Defense, Transportation and Treasury; the Office of Science and Technology Policy; the Office of Management and Budget; and the Office of the Federal Environmental Executive.

Federal coordination of current and planned biofuels activities recently took a major step forward with the National Biofuels Action Plan Workshop hosted by the Biomass Program and USDA.

The *National Biofuels Action Plan Workshop Summary Report*³⁴ describes the current and future federal agency and program roles and activities, and identifies gaps and opportunities to collaborate in all areas across the biomass-to-biofuels supply chain. Each federal agency’s current role in this collaborative effort is summarized in Table 1-1. The Biomass R&D Board will continue to lead coordination of efforts across federal agencies to bring coherence to federal biomass/biofuels strategic planning in support of the President’s AEI, “20 in 10” plan and EISA.

Biomass R&D Technical Advisory Committee: The Biomass R&D Act of 2000 also created the Biomass R&D Technical Advisory Committee to advise the Secretaries of Energy and Agriculture on the technical direction of proposed research. The Committee also facilitates partnerships among federal and state agencies, agricultural producers, industry, consumers, the research community, and other interested groups; carries out program activities; and conducts strategic planning related to the Biomass R&D Initiative. The Committee is comprised of about 30 participants from industry, academia, trade associations, non-profit environmental and conservation organizations, and state governments.

Biomass R&D Initiative: The Biomass R&D Act of 2000 directed DOE and USDA to integrate technology R&D programs through the Biomass R&D Initiative to foster a domestic bioindustry producing fuels, products, and power. Since then, the Biomass Program and USDA have co-funded a variety of projects that involve industry, agriculture and forestry, small businesses, and DOE and USDA national laboratories to address key issues for developing the bioindustry and producing biobased fuels, products, and power. The joint Biomass/USDA “Billion Ton Vision” study, which quantified the nation’s biomass resource potential, established biomass as a viable contributor to the President’s “20 in 10” plan. Since FY 2002, a joint solicitation has been issued every fiscal year under the Biomass R&D Initiative. EPAct 2005 identifies the joint solicitation topics as feedstock production through development of crops and cropping systems, overcoming recalcitrance of cellulosic biomass, product diversification through production technologies for a range of biobased products, and analysis that provides strategic guidance for the application of biomass technologies. Prior to EPAct 2005, other topics were solicited. Hundreds of proposals are received annually. Table 1-2 indicates the number of proposals funded by topic. The federal share of these projects is over \$150 million. More details on the projects can be found on the Initiative website at www.brdisolutions.com/default.aspx.

Table 1-2: DOE R&D Topics Requested in the USDA/DOE Joint Solicitations

Year	FY02	FY03	FY04	FY05	FY06
Feedstock		1	2	3	3
Conversion	6	16	7		8
Products	2	1	5	5	4
Policy/Analysis			6	3	2
Crosscut			1		

³⁴ The workshop results are available at <http://www.biofuelspostureplan.govtools.us/documents/NationalBiofuelsActionPlanWorkshopSummaryReportFinal-5-30-07.pdf>

Table 1-1: Summary of Federal Agency Roles across the Biomass-to-Biofuels Supply Chain³⁵

Federal Agency	Feedstock Production	Feedstock Logistics	Biomass Conversion	Biofuels Distribution	Biofuels End Use
Department of Energy	Sustainable land and crop management; plant science; genetics and breeding	Sustainable harvesting of biomass; sustainable crop residue removal	Biochemical conversion (pretreatment/ enzyme cost reductions); recalcitrance of biomass; thermo-chemical conversion to fuels (gasification and pyrolysis); integrated biorefineries	Safe, adequate and cost-effective biofuels transportation/ distribution systems development	Engine optimization/ certification; vehicle emissions impact; market awareness/ impact of biofueled vehicles
Department of Agriculture	Sustainable land, crop, and forest management; plant science; genetics and breeding	Sustainable harvesting of biomass; sustainable crop and forest residue removal	Biochemical conversion (pretreatment/ enzyme cost reductions); recalcitrance of forest resources; thermo-chemical conversion to fuels and power; on-farm biofuels systems; integrated biorefineries for forest feedstocks		
Environmental Protection Agency	Health/environmental impacts of biofuels supply chain lifecycle; feasibility of sustainable volumes of biofuels; feedstock improvement	Health/environmental impacts of biofuels supply chain lifecycle; permitting	Health/environmental impacts of biofuels supply chain lifecycle; biowaste-to-energy; permitting; testing protocols and performance verification; market impact of biofuels production	Health/environmental impacts of biofuels supply chain lifecycle; permitting	Health/environmental impacts of biofuels supply chain lifecycle; engine optimization/ certification; vehicle emissions impact; market awareness/ impact of biofueled vehicles
Department of Commerce / National Institute for Standards and Technology			Catalyst design, biocatalytic processing, biomass characterization, and standardization; standards development, measurement, and modeling	Materials reliability for storage containers, pipelines, and fuel delivery systems	Standard reference materials, data, and specifications for biofuels
Department of Transportation		Feedstock transport infrastructure development		Safe, adequate and cost-effective biofuels transportation/ distribution systems development	
National Science Foundation	Basic research to improve biofuels feedstocks and wastes as energy sources	Basic research to improve feedstock preprocessing	Basic research on biochemical and thermochemical conversion technologies		
Department of the Interior	Forest management	Forest management / fire prevention (recovery of forest thinnings)	Biorefinery permitting on DOI-managed lands		
Department of Defense	Basic R&D on feedstock processing (MSW/waste biomass)		Solid waste gasification		Biofuels testing

³⁵ Excerpted from National Biofuels Action Plan Workshop Summary Report (May 2007) <http://www.biofuelspostureplan.govtools.us/documents/NationalBiofuelsActionPlanWorkshopSummaryReportFinal-5-30-07.pdf>

Coordination among DOE Programs and Offices

Office of Science (SC): The Biomass Program works with SC to coordinate fundamental biomass research activities and share information about new partnerships, major research efforts, conversion and feedstock related activities, and possible joint funding requests. For example, in December 2005, SC-EERE jointly developed the research roadmap *Breaking the Biological Barriers to Cellulosic Ethanol: A Joint Research Agenda*, which outlines the basic science research needed to accelerate advances in cellulosic ethanol. The document is now guiding multiyear technical planning for both EERE and SC.³⁶

Office of Energy Efficiency and Renewable Energy (EERE): The following EERE programs are involved in working toward the vision of bioenergy.

- **Hydrogen, Fuel Cells & Infrastructure Technologies Program (HFCIT):** The production of hydrogen from biomass is pursued through two main pathways – distributed reforming of bio-derived liquids and gasification. Research efforts on bio-derived liquids and gasification are coordinated. Coordination efforts are focusing on fuels development and gas clean up. The HFCIT program is using a systems analysis approach that includes the production of hydrogen from many sources, including bio-derived hydrogen.
- **FreedomCAR and Vehicle Technologies Program (FCVT):** Research on the use of non-petroleum fuels, particularly ethanol and diesel replacements, are coordinated with FCVT. This coordination focuses on infrastructure and end use of biofuels. The Program also interfaces with EERE’s Clean Cities Program, which develops public/private partnerships to promote alternative fuels and vehicles and is currently supporting the deployment of E85 stations. The Program is participating in an Infrastructure Working Group with FCVT and the Clean Cities programs to identify barriers to the distribution and end-use of ethanol including intermediate ethanol blends.
- **Industrial Technologies Program (ITP):** Biomass-based technologies for gasification and the production of biobased fuels, chemicals, materials, heat, and electricity are of interest to ITP chemicals and forest products subprograms.
- **Federal Energy Management Program (FEMP):** FEMP works with the federal fleet to increase the use of renewable and alternative fuels and FFVs.
- **EERE Communications Office:** Program outreach efforts are supportive of and coordinated with the broader corporate efforts managed by the EERE Office of Technology Advancement and Outreach.
- **EERE Business Administration, Planning, Budget Formulation, and Analysis (PBFA):** Program analysis activities support PBFA in carrying out EERE crosscutting corporate analysis.

³⁶ <http://genomicsgtl.energy.gov/biofuels/2005workshop/b2blowres63006.pdf>

1.3 Program Goals, Schedule and Multiyear Targets

1.3.1 Program Strategic Goals

The Program’s overarching strategic goal is as follows:

Develop cost-competitive biomass technologies to enable the production of biofuels nationwide and reduce dependence on oil through the creation of a new domestic bioindustry supporting the President’s goal to reduce gasoline use 20 percent by 2017.

This strategic goal supports the *DOE Strategic Plan*³⁷ and EERE’s strategic goals³⁸ as well as the President’s AEI, “20 in 10” plan, and EISA as shown in Figure 1-9. It directly supports the Energy Security theme of the *DOE Strategic Plan* by developing a clean, domestic source of energy to diversify the U.S. energy portfolio. It also aligns with the amended Biomass R&D Act of 2000 and EAct 2005.

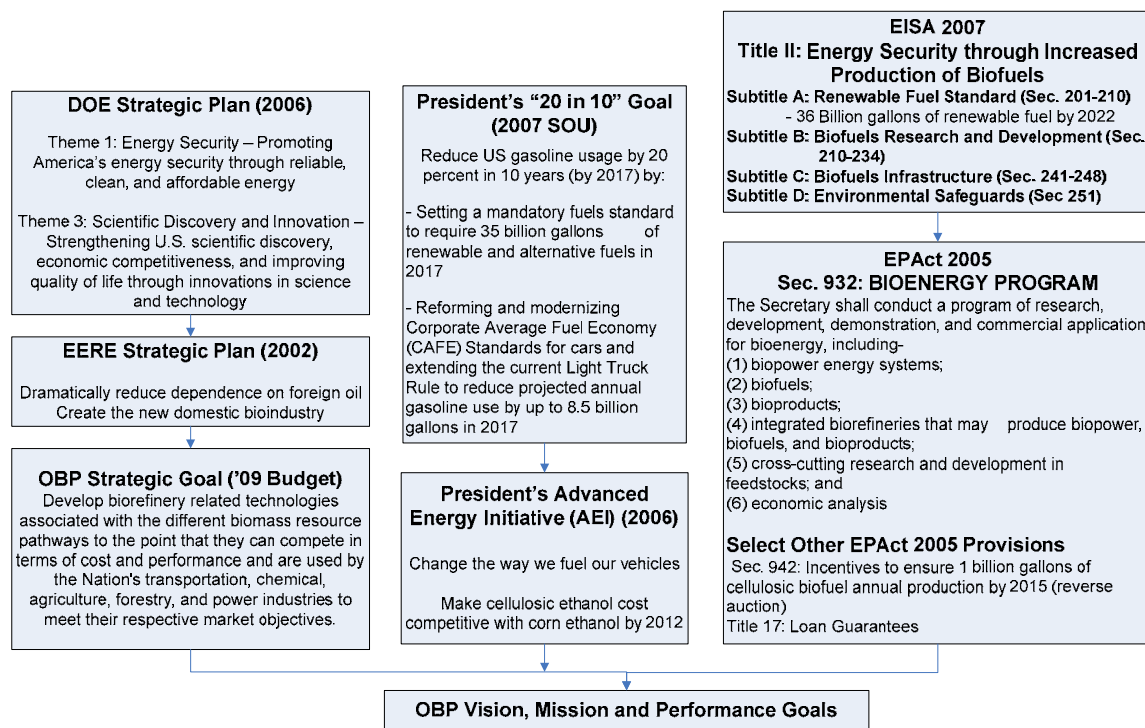

Figure 1-9: Biomass Program Strategic Goal Hierarchy

The Program’s high-level schedule aims for cost-competitive cellulosic ethanol by 2012 and supports the President’s “20 in 10” plan (Figure 1-10).

³⁷ USDOE Office of the Chief Financial Officer. *U.S. Department of Energy Strategic Plan 2006*. DOE/CF-0010, Washington, DC. (2006). Available at www.energy.gov.

³⁸ DOE Office of Energy Efficiency and Renewable Energy Strategic Plan, http://www.eere.energy.gov/office_eere/pdfs/fy02_strategic_plan.pdf

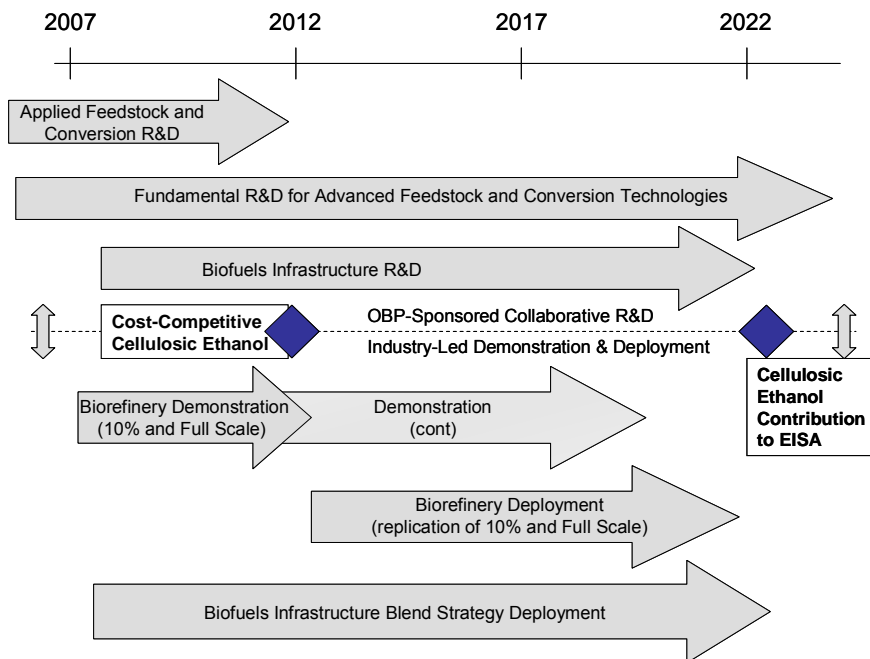

Figure 1-10: Biomass Program High-Level Schedule

The strategic goals for each program element support the overarching Biomass Program strategic goal, as shown in Figure 1-11. These goals are integrally linked—demonstration and validation activities, for example, will depend upon an available, sustainable feedstock supply, cost-effective conversion technologies, adequate distribution infrastructure, and strategic alliances and outreach to catalyze market transformation.

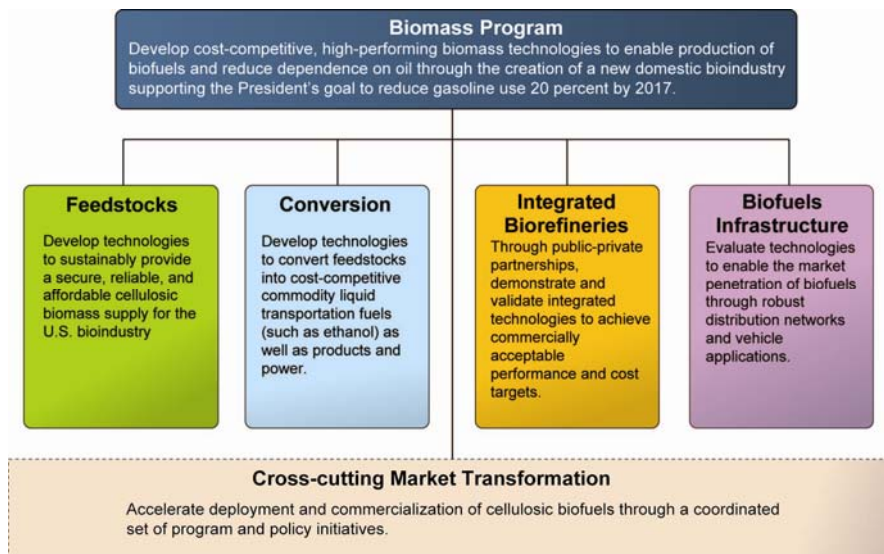

Figure 1-11: Strategic Goals for the Biomass Program

1.3.2 Program Performance Goals

The overall performance goals set for the Program reflect the current strategy of focusing on cellulosic ethanol as the most immediate path for meeting the President's goals. They address the technology advances required to reduce the cost of cellulosic ethanol and the biofuels production increases required to meet the gasoline displacement goals:

- Through RD&D, make cellulosic ethanol cost-competitive, at a modeled³⁹ cost for mature technology⁴⁰ of \$1.33/gallon by 2012 and ~\$1.20/gallon by 2017
- Help create an environment conducive to
 - maximizing the sustainable production of biofuels by 2017, including cost-effective technology, sufficient infrastructure, appropriate policies, and supportive consumers
 - displacing 30 percent of 2004 gasoline use (light duty vehicles)⁴¹ by 2030

The performance goals for each of the technical program elements are summarized below. All cost targets are in 2007 dollars of ethanol; 2017 targets are estimated and currently undergoing validation. The 2012 cellulosic ethanol cost target was established on the basis of being competitive with corn ethanol and the 2002 NREL Design Report.⁴² The 2017 cellulosic ethanol cost target was established on the basis of the Energy Information Administration's (EIA's) projected high gasoline retail price estimate adjusted to 2007 dollars, discounted to account for taxes, distribution, and marketing costs and adjusted to account for the lower energy density of ethanol. The 2017 ethanol cost target of \$1.20 per gallon of ethanol at the plant gate is highlighted in Figure 1-12.

- **Feedstock Core R&D**
 - Reduce logistics costs (including harvesting, storage, preprocessing, and transportation) to \$0.37/gallon in 2012 and \$0.33/gallon in 2017. Validate a sufficient, high-quality feedstock supply of 130 million dry tons/year (MDT/yr) by 2012 and 250 MDT/yr by 2017.
- **Conversion Core R&D**
 - Reduce the processing cost of converting cellulosic feedstocks to ethanol to \$0.82/gallon by 2012 and \$0.60/gallon by 2017.
- **Integrated Biorefineries**
 - Demonstrate integrated biorefineries across various pathways (three successful plants) by 2012. Validate mature plant modeled cost of ethanol production based on pioneer plant performance and compare to the target of \$1.33/gallon by 2017.
- **Biofuels Infrastructure**

³⁹ The modeled cost refers to the use of models to project the cost such as those defined in the NREL design reports:

- 1) "Lignocellulosic Biomass to Ethanol Process Design and Economics Utilizing Co-Current Dilute Acid Prehydrolysis and Enzymatic Hydrolysis for Corn Stover," NREL TP-510-32438, June 2002.
- 2) "Thermochemical Ethanol via Indirect Gasification and Mixed Alcohol Synthesis of Lignocellulosic Biomass," NREL/TP-510-41168, April 2007.
- 3) Feedstock Logistics Design Report (final editing in progress as of 09/27/07).

⁴⁰ The ethanol production cost targets are estimated mature technology processing costs which means that the capital and operating costs are assumed to be for an "nth plant" where several plants have been built and are operating successfully so that additional costs for risk financing, longer startups, under performance, and other costs associated with pioneer plants are not included.

⁴¹ 30% of 2004 gasoline use (light duty vehicles) is equivalent to ~60 billion gallons of ethanol.

⁴² Lignocellulosic Biomass to Ethanol Process Design and Economics Utilizing Co-Current Dilute Acid Prehydrolysis and Enzymatic Hydrolysis for Corn Stover," NREL TP-510-32438, June 2002.

- In partnership with EPA and DOT, complete standards development and testing of E15 and E20 distribution systems and vehicles. Develop capacity to transport and distribute 36 billion gallons of biofuel by 2022.

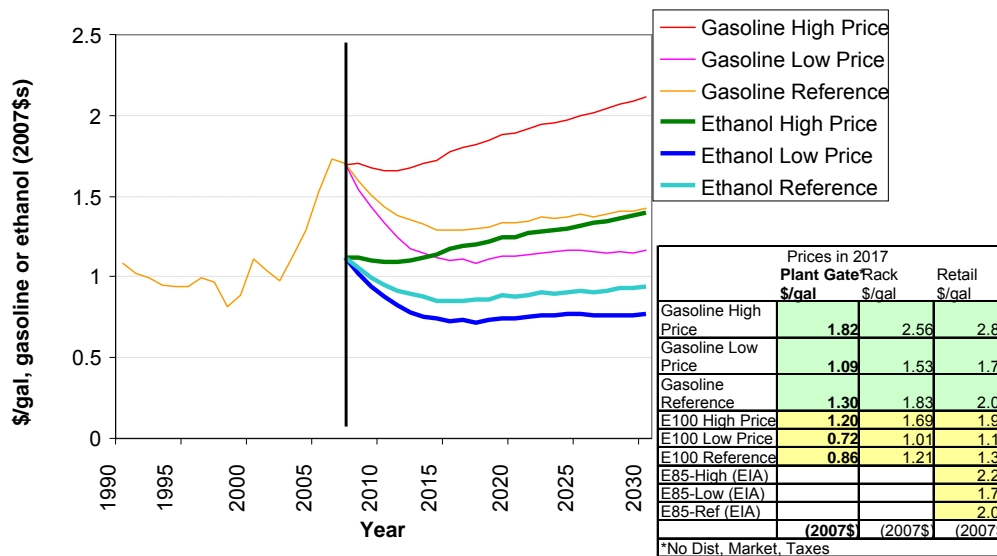

Figure 1-12: Average Plant Gate Motor Gasoline Price and Equivalent Ethanol Price (\$/gal)⁴³

The individual cost targets for feedstock production, feedstock logistics, and conversion roll up to the total Biomass Program’s 2012 and 2017 goals, as shown in Figure 1-13. Also included in Figure 1-13 is the 2007 ethanol cost status of \$2.43/gallon based on biochemical conversion as discussed in section 3.2.1.5 (it comprises of \$0.18 per gallon for feedstock production, \$0.65 per gallon for feedstock logistics and \$1.60 per gallon for conversion). The \$1.33-per-gallon ethanol cost target for 2012 is comprised of \$0.14 per gallon for feedstock production (equivalent to \$13 per ton of biomass payment, the so-called “grower payment”), \$0.37 per gallon for feedstock logistics, and \$0.82 per gallon for conversion. Technology advances reduce feedstock logistical and conversion costs to \$0.33 per gallon and \$0.60 per gallon by 2017. As the biorefinery industry matures, feedstock prices will likely increase (as is the case for most commodity feedstocks) due to the use of higher-cost biomass and natural market dynamics. The cost of feedstock production is projected to increase to \$0.27 per gallon (equivalent to a \$26 per ton grower payment) by 2017. Specific details and assumptions are provided in Section 3 and Appendices B and C.

⁴³ Data from Gasoline: AEO 2007, Table 12, Petroleum Product Prices; Ethanol: Fraction of gasoline based on volumetric LHV ratio; Plant Gate Estimate: Subtract from Retail - Taxes at 25% and Dist. & Marketing at 12% based on gasoline average 2000-2007)

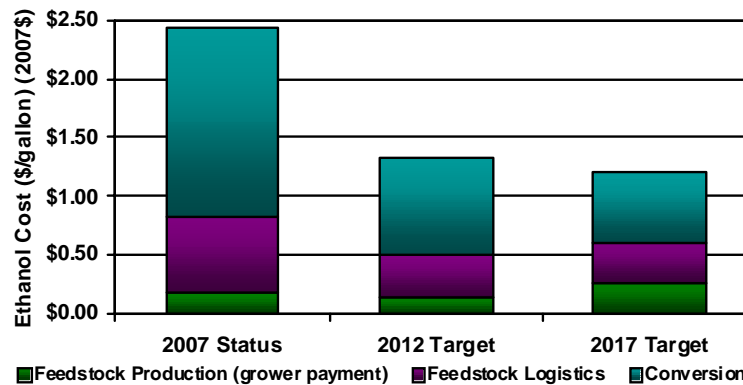

Figure 1-13: Biomass Program Feedstock and Conversion Cost Targets

1.3.3 Program Multi-Year Targets

The Program’s multi-year targets focus on the highest priority biorefinery pathway milestones. Currently, the highest priority milestones mark the routes to ethanol via corn dry mill improvements, agricultural residues processing, and energy crop processing pathways (see Appendix A for the complete list of priority milestones). Targets for the forest resources processing pathway will be determined as forest biomass R&D priorities are identified in consultation with stakeholders. The targets for 2007-2012 are summarized in Table 1-3. Only a few targets have been defined beyond 2012. As research progresses and demonstration data is collected, additional multi-year targets for 2013-2017 will be identified to track progress toward the “20 in 10” plan.

The Program’s detailed multi-year targets, technical element performance goals and milestones are presented in Section 3.

Core R&D Multi-Year Targets. For each element of core R&D, the program multi-year targets represent the culmination of work from bench scale through pilot operations to integrated pilot-scale operations. Table 1-3 shows the targets/milestones for successfully operating the integrated pilot or prototype systems and validating achievement of the defined performance metrics. Each specific design concept currently has its own set of performance metrics. The Program is working to define higher-level performance metrics that will apply to all designs for the next revision of the MYPP.

To illustrate with a specific example, Figure 1-14 shows the program-level milestones for the biochemical conversion of corn stover to ethanol. The milestones cover the progression from bench-scale demonstration to integrated pilot-scale demonstration and are aligned with the conversion platform tasks, as defined by the work breakdown structure (WBS).

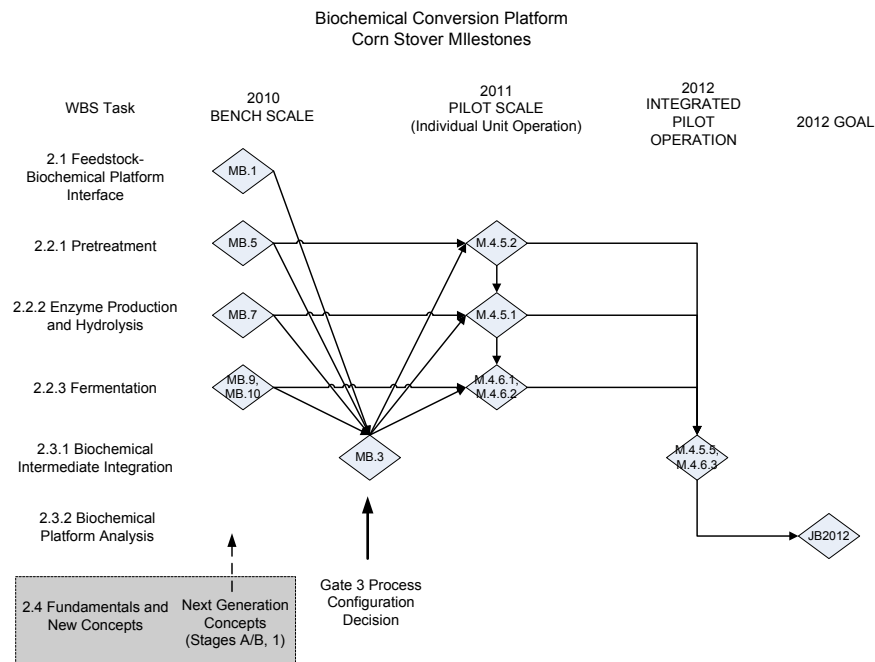

Figure 1-14: Biochemical Conversion Platform Corn Stover Milestones

The figure above shows how process development and scale-up for a particular route are planned and tracked. The process may be summarized as follows:

- Bench Scale
 - Column 1: Successful completion of bench-scale work leads to down-selection of unit operations design and configuration for corn stover (in the context of integrated process applicability)
- Gate 3 Stage Gate Review
 - Column 2: By 2010, a formal decision (via Stage 3 Gate Review⁴⁴) will be made to move to pilot-plant scale with a defined integrated process configuration for corn stover (based on bench scale data)
- Pilot Scale
 - Column 3: By 2011, individual unit operation performance for corn stover will be validated at pilot scale
 - Column 4: By 2012, integrated pretreatment, enzymatic hydrolysis, and ethanol production from corn stover will be validated at pilot scale (this is the Program’s multi-year target)
 - Column 5: By 2012, the modeled ethanol cost will be determined based on data from integrated pilot-scale operations (supports the 2012 Joule milestone)

The milestones and decision points (represented by diamonds in the diagram) are detailed in Figure 3.16 in Section 3.2 and are tied to a specific biochemical conversion route to ethanol: dry corn stover feedstock, dilute acid pretreatment, enzymatic hydrolysis and co-fermentation, and lignin combustion for heat and power. At each scale, the unit operations must meet the set of

⁴⁴ Stage Gate Management in the Biomass Program (Rev. 2, February 2005). <http://devafdc.nrel.gov/pdfs/9276.pdf>

performance metrics defined for the route, as detailed in Appendix B, Table B-4. The core R&D work on a particular process route is complete when an integrated pilot or prototype system has been successfully demonstrated and validated.

Demonstration and Deployment Multi-Year Targets. For the demonstration and deployment elements of the Program, the multi-year targets represent the first steps toward commercialization for specific routes through the priority pathways. These demonstration- and commercial-scale efforts are conducted via competitively awarded, cost-shared agreements with industry. The targets and milestones listed in Table 1-3 denote the timeline for successful operation of the full-scale system and validation of performance for each specific design. Underlying these high-level targets are milestones tracking the progression from contract award, to construction, start-up, and operation of each demonstration or commercial-scale biorefinery.

The following definitions are provided for terminology used in the programmatic milestones (including the targets in Table 1-3) presented throughout this document.

- **Downselect:** Based on bench-scale evaluation of viable processes/technologies, select the process design configuration that will move forward for demonstration in an integrated pilot plant or prototype system.
- **Demonstrate:** At pilot scale and beyond, verify that the unit operations operate as designed and meet the complete set of performance metrics (individually and as an integrated system).
- **Validate:** At pilot scale and beyond, ensure the process/system meets desired expectations/original intent. Validation goes beyond just meeting all of the performance metrics; this determines whether the system actually fulfills/completes a portion of the program effort so that the Program can move on to the next priority.

Table 1-3: Program Multi-Year Targets 2007-2022

Program Multi-Year Targets	2007	2008	2009	2010	2011	2012
Core R&D						
Feedstock						
Agricultural Residues Processing Pathway						
By 2009, validate integrated feedstock logistics for dry corn stover and dry wheat straw in prototype equipment			X			
By 2012, validate integrated feedstock logistics for wet corn stover in prototype equipment						X
Energy Crops Processing Pathway						
By 2009, validate integrated feedstock logistics for dry switchgrass in prototype equipment.			X			
By 2011, validate integrated feedstock logistics for woody energy crops in prototype equipment					X	
By 2012, validate integrated feedstock logistics for wet switchgrass in prototype equipment.						X
Conversion						
Agricultural Residues Processing Pathway						
By 2012, validate integrated pretreatment, enzymatic hydrolysis and ethanol production from corn stover (dry and wet) at pilot scale.						X
By 2009, validate integrated gasification of corn stover- and wheat straw-derived lignin to produce clean syngas at pilot-scale.			X			
By 2010, validate integrated gasification of corn stover and wheat straw to produce clean syngas at pilot-scale.				X		
By 2012, validate integrated production of ethanol from mixed alcohols produced from corn stover- and wheat straw-based (lignin or biomass) syngas at pilot scale.						X
Energy Crops Processing Pathway						
By 2017, validate integrated pretreatment, enzymatic hydrolysis and ethanol production from switchgrass (wet and dry) at pilot scale.						2017
By 2009, validate integrated gasification of hybrid poplar- and switchgrass-derived lignin to produce clean syngas at pilot-scale.			X			
By 2010, validate integrated gasification of hybrid poplar and switchgrass to produce clean syngas at pilot-scale.				X		
By 2012, validate integrated production of ethanol from mixed alcohols produced from hybrid poplar- and switchgrass-based (lignin or biomass) syngas at pilot scale.						X
Demonstration and Deployment						
Integrated Biorefineries						
Corn Dry Mill Improvements Pathway						
By 2012, demonstrate and validate economical corn fiber-to-ethanol in a corn dry grind mill.						X
Agricultural Residues Processing Pathway						
By 2012, demonstrate and validate integrated agricultural residues-to-ethanol process at demonstration or commercial scale.						X
By 2012, demonstrate and validate production of ethanol from agricultural residues (lignin- or biomass-derived) syngas at demonstration or commercial scale.						X
Energy Crops Processing Pathway						
By 2017, demonstrate and validate integrated energy crop-to-ethanol process at demonstration or commercial scale.						2017
By 2017, demonstrate and validate production of ethanol from mixed alcohols produced from energy crops (lignin- or biomass-derived) syngas at demonstration or commercial scale.						2017
Biofuels Infrastructure						
All Biorefinery Pathways to Ethanol						
By 2012, in partnership with EPA and DOT, complete standards development and testing of E15 and E20 distribution systems and vehicles.						X
Develop capacity to transport and distribute 36 billion gallons of biofuels.						2022
<p>Demonstration: At pilot scale and beyond, verify that the unit operations operate as designed and meet the complete set of performance metrics (individually and as an integrated system).</p> <p>Validation: At pilot scale and beyond, ensure the process/system meets desired expectations/original intent. Validation goes beyond just meeting all of the performance metrics; it is an assessment of whether the system actually fulfills/completes a portion of the program effort so that the Program can move on to the next priority.</p>						

SECTION 2: PROGRAM PORTFOLIO MANAGEMENT

This section describes how the Biomass Program develops and manages its portfolio of RD&D activities. It identifies and relates many different types of planned portfolio management activities including portfolio decision making, analysis (described in Section 2.2), and performance assessment (described in Section 2.3).

2.1 Program Portfolio Management Process

The Biomass Program manages its portfolio based on the approach recommended under the EERE Program Management Initiative,¹ improved upon by new processes derived from classical systems engineering approaches for managing technically complex programs. The five major steps in the Program portfolio management process are shown in Figure 2-1 and described below.

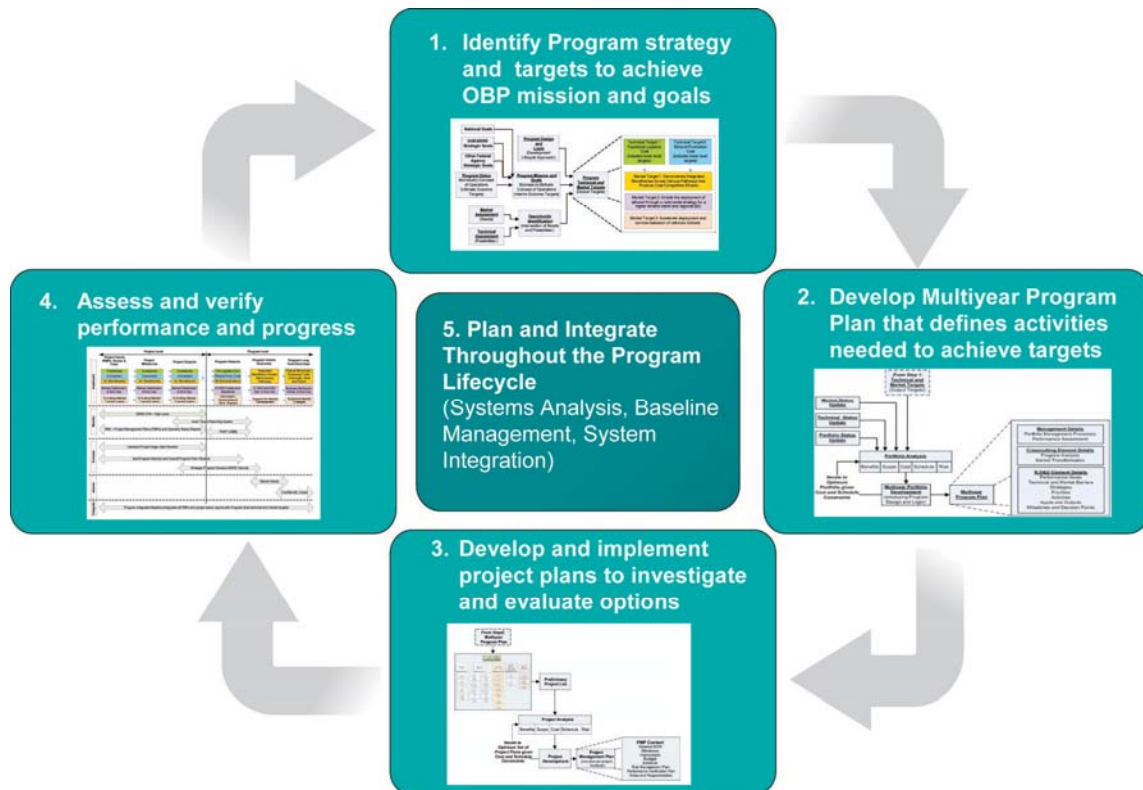

Figure 2-1: Program Portfolio Management Process

Step 1: Identify Program Strategy and Targets to Achieve Program Mission and Goals

This step, illustrated in Figure 2-2, summarizes the process of developing the Program mission and goals (outlined in Section 1), both of which were derived from a combination of the Program's strategic goal hierarchy (Figure 1-9) and the Program vision.

¹ The EERE Program Management Initiative was launched in 2003 to address stakeholder expectations, the President's Management Agenda, DOE and EERE strategic plans, findings and recommendations by the National Academy of Public Administration, and the Government Performance and Results Act. Complete information is available at http://www1.eere.energy.gov/ba/prog_mgmt_initiative.html.

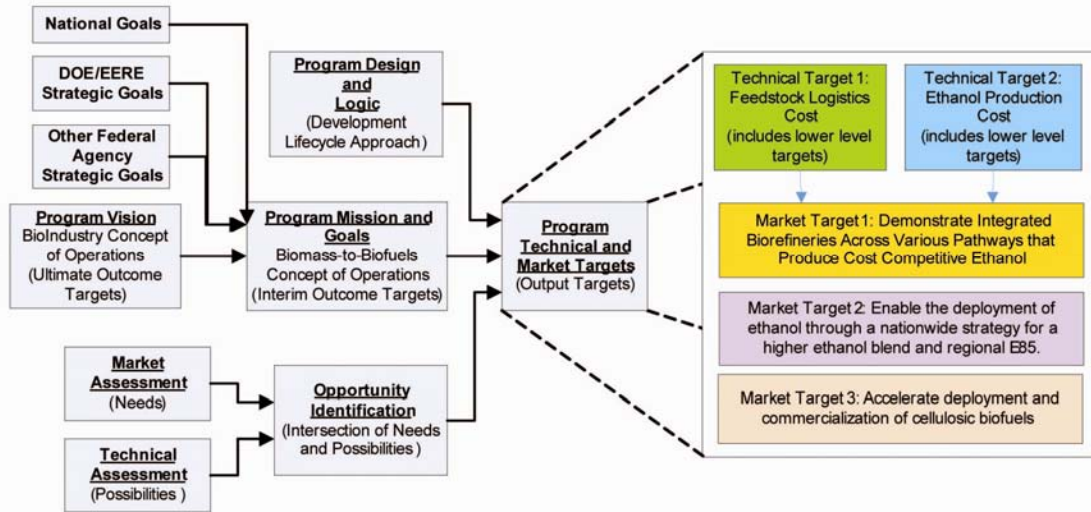

Figure 2-2: Step 1. Identify Program Strategy and Targets to Achieve Program Mission and Goals

The Program design and logic (Figure 1-8) detail how the mission and goals fit within the planning and budgetary framework of the Program. Combining the Program design and logic with an understanding of market needs and technical scenarios leads to the definition of Program targets that are consistent with government objectives. Targets are allocated to the Program elements responsible for managing and funding research related to the targets.

Portfolio decision making at the strategic level is based on three main criteria:

- Does the portfolio conduct RD&D that meets the technical and/or market targets designed to achieve Program goals?
- Does the portfolio develop technology that can contribute to producing competitively priced biobased fuels for the transportation sector of the United States?
- Does the portfolio lead to establishing the biofuels industry in the United States?

As coordination of federal agencies increases under the guidance of the Biomass R&D Board, the strategic goals and scope of the other agencies' efforts should become clearer. The Program will use this input to reassess the Program's mission, goals and targets in the future.

Step 2: Develop MYPP That Defines Activities Needed to Achieve Targets

As shown in Figure 2-3, Step 2 guides how the Program develops its Multiyear Plan to outline the path to achieving the high-level Program technical and market targets defined in Step 1.

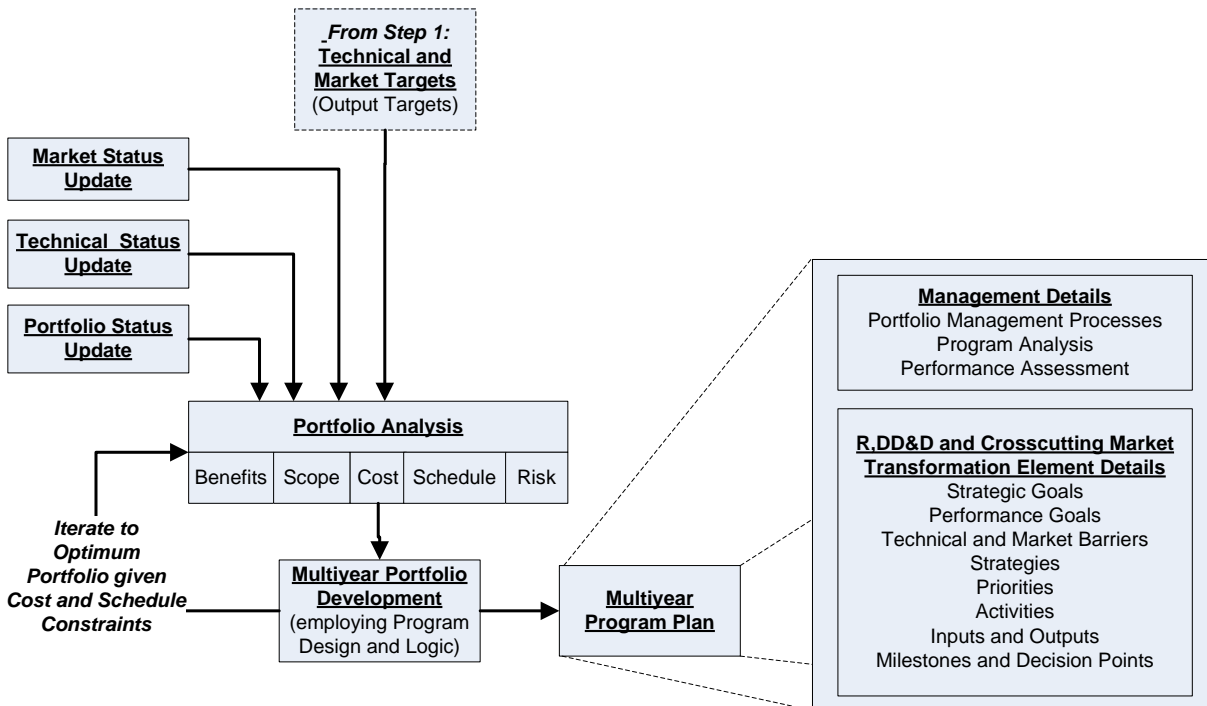

Figure 2-3: Step 2. Develop Multiyear Program Plan that Defines Activities Needed to Achieve Targets

Portfolio analysis is carried out to determine the optimum portfolio to achieve the targets. Factors considered include the level of benefits expected, scope, cost, schedule, and risk to realizing the program benefits. This is an iterative process that weighs benefits against costs and risks while taking into account the latest external information regarding market, technical status, and barriers as well as the updated status of the portfolio efforts based on verified, externally reviewed progress. Each RD&D element has performance goals and barriers identified through evaluation and public-private collaborative meetings. Programmatic priorities to address the barriers are determined by balancing the needs and driving forces behind the emerging industry within the context of inherently governmental activities. Gaps that are identified are addressed, while recognizing and maintaining the interfaces between the elements so that all parts of the supply chain are developed in parallel to comparable levels of maturity over time. Analytical methodologies and tools employed to inform the portfolio analysis and decision-making process are described in Section 2.2. The Multiyear Program Plan (MYPP) is designed to undergo review and be updated on a regular basis.

Step 3: Develop and Implement Project Plans to Investigate and Evaluate Options

Step 3 is illustrated in Figure 2-4 and involves developing individual project management plans (PMPs) that are aligned with the Multiyear Plan. The PMPs define the work required to investigate and evaluate the selected approaches for achieving the Program level technical and market targets, and milestones in the MYPP.

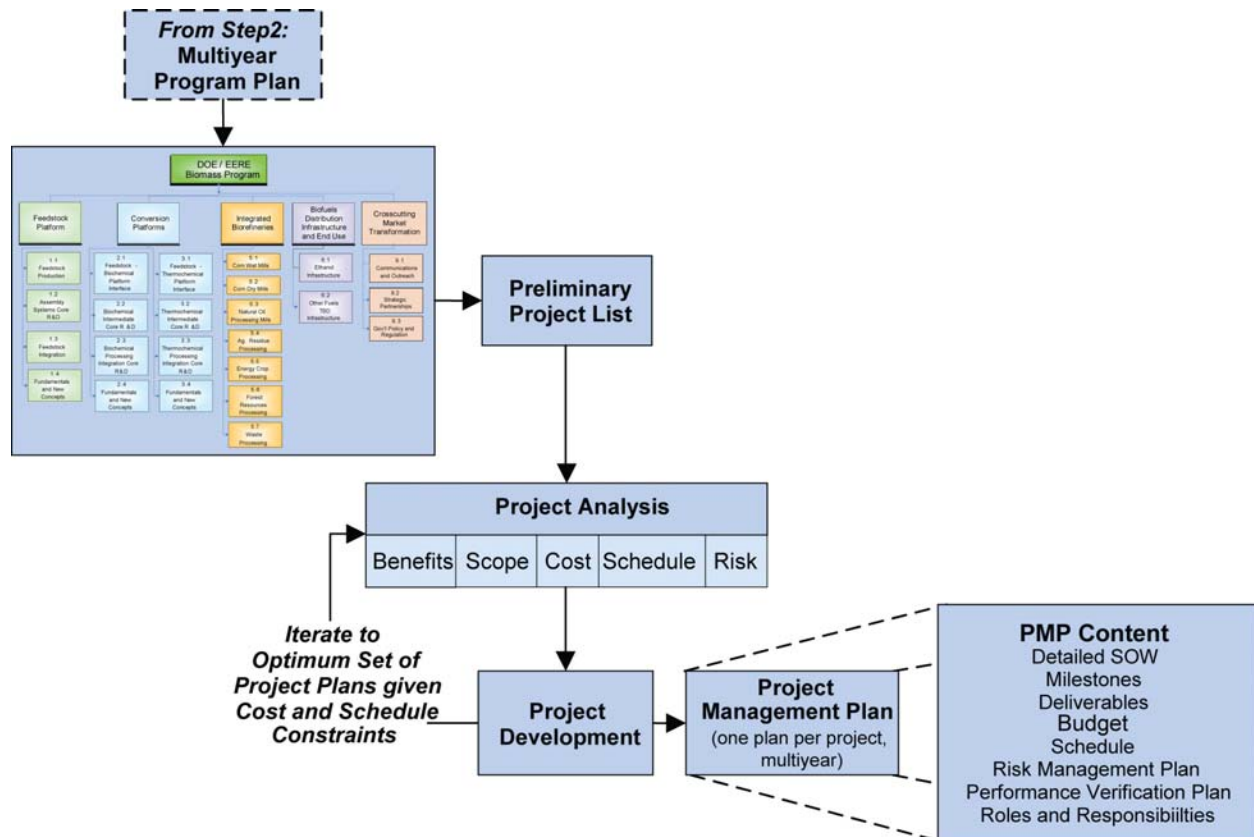

Figure 2-4: Step 3. Develop and Implement Project Plans to Investigate and Evaluate Options

Project development and analysis are used to define a portfolio of effective projects that when combined will most efficiently achieve the Program targets. Factors considered at the project level are similar to those considered at the portfolio level in Step 2 and include potential benefits, scope, cost, schedule, and risk. Also like Step 2, this is an iterative process that weighs benefits against costs and risks, however the emphasis is on the specific projects under consideration and how they compare to each other as well as their relevance to the Program. At the initiation of a project, its PMP is prepared to describe the entire project duration. PMPs are updated at least annually based on actual progress, results of interim stage gate reviews, and updates to the Program Multiyear Plan.

Step 4: Assess and Verify Performance and Progress

Step 4, as shown in Figure 2-5, involves a system of performance assessments held on multiple levels to monitor and evaluate performance and progress as the Program is implemented (described in detail in section 2.3). The Project Management Center (PMC) evaluates project performance to schedule, scope and cost on a quarterly basis using the PMPs as the baseline. The Program’s subprogram element peer reviews and an overall Program peer review are conducted biennially to inform decision making on future funding and direction. Stage gate reviews are conducted at the individual project level to assess technical, economic and market potential and risk and to identify environmental and regulatory issues. In large-scale demonstrations and pioneer conversion facilities involving public-private partnerships, independent expert analysis, stage gate decision making, and evaluation by the PMC contribute to project risk assessments and go no/go decisions. This is a significantly more rigorous approach than employed in the

Program’s R&D performance assessment efforts, but is consistent with the significantly higher level of investment.

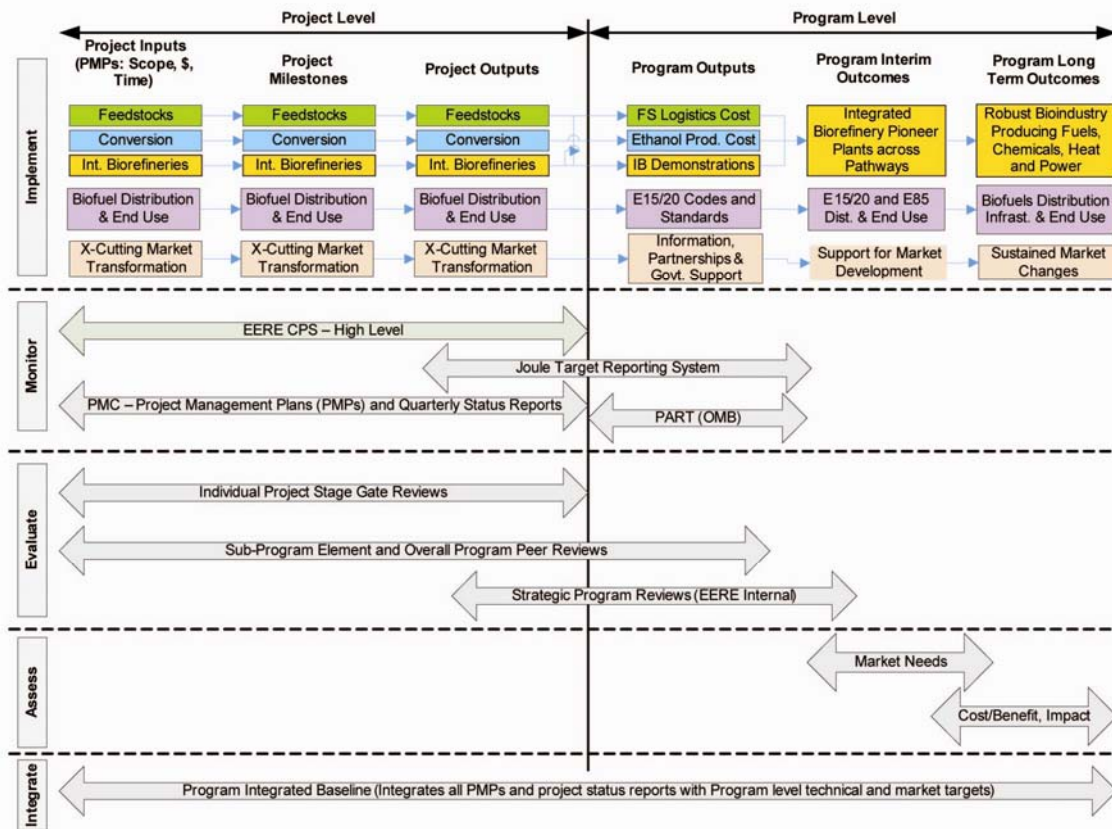

Figure 2-5: Step 4. Assess and Verify Performance and Progress

Step 5: Plan and Integrate Throughout the Program Lifecycle

Step 5 includes crosscutting technical integration efforts designed to help Program and Project Managers strengthen their management approaches to ensure a coordinated research and development effort, in addition to a well-integrated approach to technology demonstration and deployment. The diversity of technology options in each supply chain element, and the distribution from applied science to demonstrations leads to significant decision-making challenges. The Biomass Program’s efforts to improve its management, analysis, and assessment efforts are supported by the Biomass Systems Integration Office. The focus of systems analysis is to understand the complex interactions between new technologies, system costs, environmental impacts, societal impacts, system trade offs, and penetration into existing systems and markets. The goals of integrated baseline management are to provide and maintain the links between the program areas. Top-down technical baseline management evaluates the links between the mission, strategies, and performance and the goals, milestones and decision points of the Program. Bottom-up programmatic baseline management evaluates the links of the scope, budgets and schedules of the individual projects and activities of the Program.

2.2 Program Analysis

The Biomass Program conducts a broad spectrum of analyses—resource and infrastructure assessment, technical and economic feasibility analysis, integrated biorefinery analysis, deployment analysis, environmental analysis, risk assessment, and benefits analysis—to support decision-making, demonstrate progress toward goals, and direct research activities.

Programmatic analysis (or strategic analysis) helps frame the overall program goals and priorities and covers issues that impact all platforms such as lifecycle assessment of greenhouse gas emissions from ethanol. Platform-level analysis helps to monitor and check the program accomplishments in each platform. Maintaining these capabilities at the cutting edge is essential to ensure that the analysis provides the most efficient and complete answers to technology developers and the Program Management. The analytical methodologies and tools used by the Biomass Program are outlined below.

2.2.1 Description of Analytical Methodologies and Tools

Resource and Infrastructure Assessment: Resource assessment determines the quantity and location of biomass resources at regional, state, and county levels. Additionally, resource analysis quantifies the cost of the resources as a function of the amount available on a sustainable basis for utilization.^{2,3} A variety of integrated modeling tools (i.e., Policy Analysis System or POLYSYS⁴), dynamic production models (i.e., EXTEND⁵), and databases are used for estimating current and forecasted sustainable feedstock supplies. Geographic Information Systems (GIS) modeling tools⁶ can be used to portray and analyze resource data. Optimal methods for collection, transportation, and storage of biomass feedstocks are identified and can be simulated in the Integrated Biomass Supply Analysis and Logistics (IBSAL⁷) model.

Technical and Economic Feasibility Analysis: The majority of technical and economic analyses is performed as part of each platform element. Feasibility analysis determines the potential viability of a process or technology and helps to identify the most significant opportunities for cost reduction. Results from the feasibility analysis provide input to decisions regarding portfolio development and technology validation plans. The economic competitiveness of a technology is assessed by evaluating its implementation costs for a given process compared with the costs of either current technology or other future options. These analyses are useful in determining which projects have the highest potential for near-, mid-, and long-term success. Parameters studied include production volume benefits, economies of scale, process configuration, materials, and resource requirements. Tools used for technology feasibility analysis include unit operation design flow and information models, process design and

² *Biomass as Feedstock for a Bioenergy and Bioproducts Industry: The Technical Feasibility of a Billion-Ton Annual Supply*, DOE/GO-102005-2135, DOE/USDA, April 2005 (<http://feedstockreview.ornl.gov>).

³ *Roadmap for Agriculture Biomass Feedstock Supply in the United States*, DOE/NE-ID-11129 Rev 0, 2003 (<http://devafdc.nrel.gov/pdfs/8245.pdf>).

⁴ For information, see <http://apacweb.ag.utk.edu/polysys.html>.

⁵ For information, see <http://www.imaginethatinc.com/>.

⁶ For information, see <http://www.esri.com/>.

⁷ For information, see <http://bioenergy.ornl.gov/main.aspx> (click on 'models').

modeling (e.g., Aspen Plus⁸), capital costs (e.g., Aspen ICARUS⁹) and operating cost¹⁰ determination, discounted cash flow analysis, and Monte Carlo sensitivity analysis/risk assessment (e.g., Crystal Ball¹¹).

Integrated Biorefinery Analysis: Integrated biorefinery analysis is an application of technical and economic feasibility analysis that will examine specific technologies and products (i.e., fuels, products and power) being implemented by joint projects with industrial partners. Methodologies will be required that allow comparisons of the potential benefits of integrated biorefineries as they approach commercial reality, and as the Program will need to make important funding decisions regarding high-cost projects such as pilot-scale integration, large-scale demonstration, and loan guarantees.

Deployment Analysis: Analyses exploring how rapidly cellulosic ethanol technologies might be deployed to make a significant contribution to the country's transportation energy needs to be conducted. Modeling of this transition will accomplish the following:

- Identify and evaluate paths by which biomass can make a large contribution to meeting future demand for energy services. This will help answer questions such as:
 - Which technologies are most likely to be a part of the biobased future?
 - What are the interactions between these technologies and other established technologies?
 - What are the scenarios for biomass use in energy, transportation, and chemical markets?
 - What market penetration pathways are likely?
- Determine what can be done to accelerate biomass energy use and once deployed, when associated benefits can be realized, by understanding:
 - What external economic factors are most important?
 - What are the most likely bottlenecks or limiting factors?
 - What are the effects of government policy?

Detailed models of the complete supply chain from production of fuels from biomass feedstock through utilization of the fuel in vehicles have been developed using a commercially available dynamic systems model such as STELLATM.¹² The overall general structure of this model is shown conceptually in Figure 2-6. The dynamics of the growth of each component in the supply chain are determined by the timing of the build-up of the infrastructure associated with each step. The build-up of the infrastructure is determined by the dynamics of investor decisions, which in turn is driven by the performance and cost competitiveness of the fuels and the potential demand for them in the marketplace. Finally, government policy and external economic factors are evaluated for their impact on attracting investment in biofuels technology.

⁸ Aspen Plus[®] is a process modeling tool for steady state simulation, design, performance monitoring, optimization and business planning widely used in the chemicals, specialty chemicals, petrochemicals and metallurgy industries. Information is available at <http://www.aspentech.com/>.

⁹ For information, see <http://www.aspentech.com/>.

¹⁰ As an example, chemical supply costs are taken from The Chemical Marketing Report and labor costs from related industries such as corn ethanol production

¹¹ For information, see <http://www.decisioneering.com/>.

¹² For information, see <http://www.iseesystems.com/>.

Other types of infrastructure assessments identify the existing infrastructure throughout the supply chain that could be leveraged by the emerging bioindustry, as well as the developments needed to support industry growth in the future. Examples include infrastructure assessments of the U.S. liquid transportation fuel distribution network or the characteristics and expected changes in national vehicle stocks and the implications for acceptance of alternative fuels.¹³

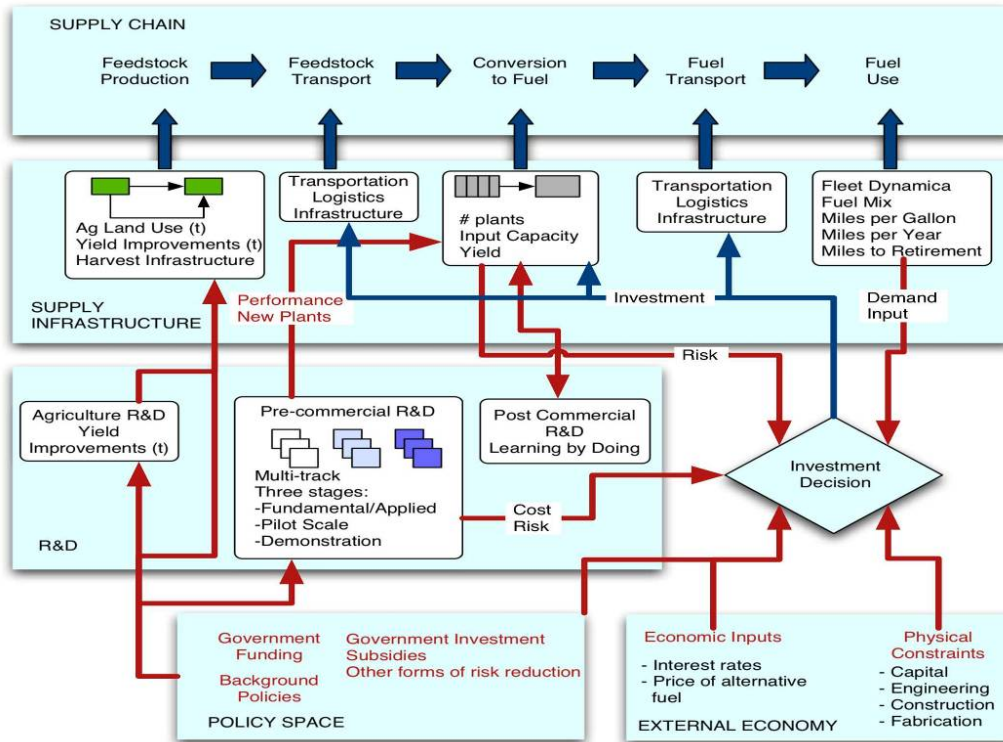

Figure 2-6: Conceptual Schematic of Bioindustry Transition Model

Environmental Analysis: The Program uses analysis to quantify the environmental impacts of biomass production and utilization technologies. Specifically, life cycle assessment (LCA) is used to identify and evaluate the emissions, resource consumption, and energy use in all steps of the process of interest, including raw material extraction, transportation, processing, and final disposal of all products and byproducts.^{14,15,16,17,18,19} Also known as cradle-to-grave or well-to-

¹³ Bob Reynolds, “Infrastructure Requirements for an Expanded Fuel Ethanol Industry”, available at <http://www.ethanolrfa.org/resource/reports/>, January 2002.

¹⁴ *Mobility Chains Analysis of Technologies for Passenger Cars and Light-Duty Vehicles Fueled with Biofuels: Application of the GREET Model to the Role of Biomass in America’s Energy Future (RBAEF) Project* (July 2005), <http://www.transportation.anl.gov/pdfs/TA/344.pdf>.

¹⁵ *Well-to-Wheels Analysis of Advanced Fuel/Vehicle Systems – A North American Study of Energy Use, Greenhouse Gas Emissions, and Criteria Pollutant Emissions* (May 2005), <http://www.transportation.anl.gov/pdfs/TA/339.pdf>.

¹⁶ *Energy and Environmental Aspects of Using Corn Stover for Fuel Ethanol*, Journal of Industrial Ecology Special Issue on Biobased Products, Vol.7, Sheehan, John; Andy Aden, Keith Paustian, Kendrick Killian, John Brenner, Marie Walsh, Richard Nelson, (June 2004), <http://devafdc.nrel.gov/pdfs/8427.pdf>.

¹⁷ *Fuel-Cycle Energy and Emission Impacts of Ethanol-Diesel Blends in Urban Buses and Farming Tractors*, (July 2003), <http://www.transportation.anl.gov/pdfs/TA/280.pdf>.

¹⁸ *The Energy Balance of Corn Ethanol: An Update* (July 2002), Shapouri, H., <http://www.transportation.anl.gov/pdfs/AF/265.pdf>.

¹⁹ *Life Cycle Inventory of Biodiesel and Petroleum Diesel for Use in an Urban Bus*, Sheehan, J.; Camobreco, V.; Duffield, J.; Graboski, M.; Shapouri, H, NREL/SR-580-24089, (May 1998), <http://devafdc.nrel.gov/pdfs/3813.pdf>.

wheels analysis, this methodology helps users understand the full impacts of existing and developing technologies, such that efforts can be focused on mitigating negative effects. Standardized LCA methodologies and established databases of material and energy flow inventories for common chemical and energy processes (e.g., Tool for Environmental Analysis and Management – TEAM²⁰ and its supporting database, Data for Environmental Analysis and Management – DEAM) are used to evaluate the impact of complete processes on the environment. The Greenhouse Gases, Regulated Emissions, and Energy Use in Transportation²¹ (GREET) model is used to estimate fuel-cycle energy use and emissions associated with alternative transportation fuels and advanced vehicle technologies. Transportation infrastructure investment tradeoff and implications of scaled production on land use, transportation, global carbon budget, and indirect economic impacts (such as food prices) in geographical context need to be analyzed in cooperation with DOE.

Benefits Analysis: Benefits analysis helps the program quantify and communicate the overarching outcomes from biomass research, development, and deployment—such as imported oil displacement and greenhouse gas mitigation—using integrating models such as National Energy Modeling System (NEMS) and Market Allocation (MARKAL). The scenarios that are developed and the costs and benefits that are quantified are used to develop a broad understanding of the most viable routes for achieving biomass utilization. Results are useful in crosscutting benefits analysis and are one of the key inputs to decision-making across all renewable technologies in the EERE portfolio.

Using the program-provided outputs and assumptions, the Office of Planning, Budget, and Analysis (PBA) works with the Program to prepare the technical assumptions needed to run the NEMS and MARKAL models. These models estimate the economic, energy, and environmental outcomes that would occur over the next 20 to 50 years if the program is successful and the future unfolds according to the business-as-usual scenario. PBA also coordinates the assessment of Government Performance and Results Act (GPRA)²² benefits, which estimate some of the economic, environmental, and security benefits or outcomes from achieving Program goals.

2.2.2 Analytical Activities in the Biomass Program

The analysis work planned for the next 5 to 10 years builds on past efforts to understand the economic factors and key uncertainties related to biomass technologies and systems. Continued public-private partnerships with the biomass scientific community and multi-lab coordination efforts will help ensure that the analysis results from the program are transparent, transferable, and comparable. Analysis activities are conducted mainly through the technology elements (platforms) and are focused as follows.

Feedstocks Analysis: Feedstocks analysis evaluates biomass collection, transport, and storage options. The supply chain is assumed to be optimized to provide the lowest delivered cost of biomass. Analytical models and tools are regularly updated and validated with stakeholder input,

²⁰ TEAM™ enables the user to describe any industrial system and to calculate the associated life cycle inventories and potential environmental impacts according to the current ISO 14040 series (for LCA) of standards. Information is available at http://www.ecobalance.com/index_uk.html.

²¹ For information, see <http://www.transportation.anl.gov/software/GREET/index.html>.

²² <http://www.whitehouse.gov/omb/mgmt-gpra/gplaw2m.html>

emerging feedstock field data from DOE/USDA projects and supply data from biorefinery projects. The goal is to define minimum cost options for biomass collection and handling.

Conversion Analysis: Biochemical and Thermochemical platform analyses support the ongoing research in conversion of lignocellulosic biomass for an integrated biochemical/thermochemical biorefinery.²³ Specifically, these analyses have three goals: (1) Track research improvements and determine their contribution to reducing the cost of converting cellulosic feedstocks to ethanol; (2) Identify areas of largest potential for cost reduction to guide research; and (3) Provide biorefinery (biochemical and thermochemical) analysis to support deployment and transition analyses.

Integrated Biorefineries: Integrated biorefineries analysis supports the advancement of biomass-based technologies into integrated systems. Specific objectives include continued development of biorefinery pathway models based on near-term existing grain and wood industries, mid-term pathway models based on agricultural residues, and long-term pathways based on energy crops.

Risk Assessment: The identification, quantification, and evaluation of risk are used to better focus resources where they are most critical and thus help manage risks. Clearly identifying the critical path technologies and addressing the potential showstoppers will encourage greater private sector investment by increasing confidence in the likelihood of technical success. The systematic delineation of the risks in multiple pathways will identify key bottlenecks to commercial deployment and assist the Program in prioritizing investment among pathways. Risk analysis will be conducted across the program activities along with benefits analysis.

The major objective of risk assessment is evaluating the technology development underway for biomass conversion to fuel ethanol and combining that assessment with knowledge of industry deployment requirements and best practices to maintain focus toward meeting the Program goals. This assessment will include all R&D efforts that DOE has sponsored and, to the extent possible, non-DOE efforts. Projects making good progress toward the goals will be identified, as well as those that are making little progress or are not contributing. The gaps remaining in technology development will be identified. Finally, commercialization pathways will be identified with an estimate of effort (financial and time). The risk assessment tools must however be credible for industry, researchers, and managers to realize these opportunities.

2.2.3 Impact on Program R&D and Deployment Decision Processes

Analysis activities give the Biomass Program context and justification for decisions at all levels by providing the basis for quantitative metrics. Benefits analysis tracks progress toward DOE and EERE goals, while technical analysis directs R&D projects on a daily basis. Overall, analysis quantifies goals, targets, and results, and provides potential alternative directions.

Analysis plays three main roles in the Biomass Program decision-making process:

- Defines and validates performance targets for biomass technologies and systems;

²³ Recent examples of this type of supporting analyses are *** Thermochem **** and *Lignocellulosic Biomass to Ethanol Process Design and Economics Utilizing Co-Current Dilute Acid Prehydrolysis and Enzymatic Hydrolysis for Corn Stover*, A. Aden, M. Ruth, K. Ibsen, J. Jechura, K. Neeves, J. Sheehan, and B. Wallace, NREL/TP-510-32438, National Renewable Energy Laboratory, Golden, CO, 2002, <http://www.nrel.gov/docs/fy02osti/32438.pdf>.

- Guides program planning functions, R&D project selection, and assessment of progress; and
- Provides engineering knowledge for biorefinery development.

Performance Targets: The information and assessment functions in analysis define the performance targets that must be met to overcome barriers and achieve commercial success. As noted, design analysis studies have yielded specific conversion cost targets. These cost targets are defined in section 1.3.2. Progress toward these targets is monitored and the resulting data is then used in the models to improve the analyses, allowing the program to better define targets and continually shape the Program's portfolio.

Guidance for Project and Program Planning: Analysis directs and guides the Program in planning by providing a basis for setting priorities, considering options, and selecting projects that collectively will result in the program meeting its goals. Engineering and analysis are used in the stage gate management process²⁴ to determine the technical feasibility and competitive advantage of projects. The level of rigor of the analysis depends on the stage of project development, the level of maturity of the technology, and the intended application. As the projects move along the development pathway, the technical and economic assessments become more robust and accurate because they are based on data from larger-scale integrated tests. For research and development projects, simply developing a process design may identify barriers that must be overcome before the project concept can become commercially viable. Demonstration projects require material and energy balance closures, capital cost quotes, and site-specific designs.

The projects in the Biomass Program portfolio undergo stage gate reviews to assess development status and readiness to move into further stages of development. This and other Program assessments are described in section 2.3.

Engineering Knowledge for Biorefinery Development: Engineering knowledge is necessary to design, construct, and operate the plants that will comprise a successful commercial bioindustry, and develop the feedstock infrastructure to support it. Conceptual engineering design and analysis provides interested parties with the information they need to evaluate the commercial potential of biomass technologies. The dissemination of biomass conceptual design information is necessary to enable widespread investigation of biomass processes. A better understanding of the potential commercialization processes can help reduce the technical and financial risk associated with pioneer plants. Scaleable kinetic models, improved physical property data, and uncertainty analysis can all help to reduce the risks associated with the commercialization of bio-based technologies. The Biomass Program disseminates engineering knowledge through the publication of comprehensive design reports. These reports establish the credibility and transparency of the program's work and enable integration across biomass research areas, both in the program and in the biomass community at large.

²⁴ Stage gate management is described in more detail in section 2.3.

2.2.4 Key Assumptions

The program is heavily involved in assessing various processes and systems directed toward the production of bio-based fuels, products and power. Each process or system has its own set of specific assumptions. However, a general set of assumptions can be applied to all efforts:

- Fuels – All near- and mid-term biofuels must be fungible with existing liquid fuels and the existing distribution infrastructure. This does not apply to fuels produced and consumed within a biorefinery.
- Products – Bioderived co-products that are able to replace an existing chemical or material within the market must have competitive performance parameters and list price. For co-products providing new functionality or applications, the performance and costs must be competitive within the market application.
- Power – Biopower includes fungible energy products.
- Integrated Biorefineries – An integrated biorefinery is defined as an operation using biomass feedstocks that produces a fungible biofuel and other products (including heat and power).

2.3 Performance Assessment

Performance assessment includes performance monitoring and program and project evaluation. It provides the means to measure relevant outputs and outcomes that aid the Program in re-evaluating its decisions, goals, and approaches and tracks the actual progress being made. By design, the assessment processes provide the Program with input on Program progress and effectiveness from other government, stakeholders and independent expert reviewers.

Table 2-1: Program and Project-Level Assessments that Support Decision-Making

Assessment Type		Assessment Synopsis	Documentation
Performance monitoring	External monitoring	DOE's Joule performance measurement tracking system	Joule System Reports
		Office of Management and Budget's (OMB) Program Assessment Rating Tool (PART) ²⁵	PART Report
	Internal monitoring	EERE's Corporate Planning System (CPS)	CPS Database/Website
		Project Monitoring with PMC Quarterly Reports	PMC Project Management Database
	Program Monitoring with Integrated Baseline Update	CORE ²⁶ Integrated Baseline Reports	
Program evaluation	Peer reviews	Conducted by independent experts outside of the program portfolio to assess quality, productivity, and accomplishments; relevance of program success to EERE strategic and programmatic goals; and management. ²⁷	Public summary documents including Program response
	General program evaluation studies	Conducted by independent outside experts to examine process, quantify outcomes or impacts, identify market needs and baselines, or quantify cost-benefit measures as appropriate. ²⁸	Public Reports and Documentation

²⁵ PART guidance is provided by OMB. FY2007 instructions available at http://www.whitehouse.gov/omb/part/fy2007/2007_guidance_final.pdf

²⁶ CORE is a systems engineering software package.

²⁷ EERE Peer Review Guide. U.S. Department of Energy, Office of Energy Efficiency and Renewable Energy, August 2004. <http://www1.eere.energy.gov/ba/pdfs/2004peerreviewguide.pdf>, accessed 10/6/06.

²⁸ "EERE Guide for Managing General Program Evaluation Studies: Getting the Information You Need," DOE/EERE. February 2006.

Performance monitoring and Program evaluation	<i>Technical Program Reviews</i>	EERE Senior Management	EERE Internal
		Biomass R&D Technical Advisory Committee	Report to Congress, including Program response
	<i>Technical Project Reviews</i>	Stage Gate Reviews conducted by DOE only for public-private demonstration projects, DOE plus independent industry, academia, other government for pre-competitive R&D projects.	Internal reports for public private demonstration projects, public information for pre-competitive R&D projects

External Performance Monitoring

The Office of Management and Budget (OMB) requires the use of two systems to monitor program performance. The first is the Joule System, a quarterly and annual assessment of performance-based program and management results. Each program is responsible for establishing and monitoring quarterly milestones and ultimately the yearly Joule target. Joule milestones are reported to the OMB quarterly to evaluate progress toward targets as outlined in Congressional Budget Request. The second system, the Program Assessment Rating Tool (PART), also managed by OMB, was developed to assess and improve program performance so that the federal government can achieve better results. The PART looks at all factors that affect and reflect program performance including program purpose and design; evaluations and strategic planning; program management; and program results. Since the PART includes a consistent series of analytical questions, it allows programs to show improvements over time, and allows comparisons between similar programs. For R&D programs, the PART also incorporates the R&D investment criteria developed under the President’s Management Agenda. The R&D criteria include relevance, quality, performance, as well as additional specific criteria for programs developing technologies that address industry needs.²⁹ The Biomass Program has designed its peer review and stage gate management processes to address these R&D investment criteria.

Internal Performance Monitoring

The Program utilizes the Corporate Planning System (CPS) to help formulate, justify, manage and execute Congressional Budget Requests. CPS also serves as a management tool to enable prospective spend planning, project data collection, and portfolio performance assessment. The system stores project-level management data, such as scope, schedule and cost and tracks progress against technical milestones.

The performance of the projects (“agreements” in CPS) is monitored and managed by the PMC. Standardized processes used include:

- PMPs are developed to provide details of work planned over the entire project duration and to establish measures for evaluating performance. The plans include multi-year descriptions, milestones, schedules, and cost projections. The PMPs are updated annually.
- Quarterly project progress reports are submitted by the funded organizations outlining financial and technical status, identifying problem areas and highlighting achievements. Site reviews are conducted by the PMC annually (at a minimum) for technology validation, assessment of obstacles, and to review the work in progress. The PMC performs an assessment of project progress against the planned scope and schedule and

²⁹ See Appendix C of the 2007 PART Guidance for additional information on R&D investment criteria.

financial performance against the cost projection on a quarterly basis, and documents the assessment in a quarterly management report.

With well over 100 projects in the portfolio, the project plan and progress information must be summarized and synthesized in order to evaluate overall program performance in a meaningful way. One of the benefits of instituting the pathway approach (described in Section 1.0) is that projects can be grouped logically, according to the type of feedstock and/or biorefinery configuration to which they contribute. Evaluation of the overall technical progress on a pathway can be determined by the collective progress of the contributing projects. The Program has implemented a systems engineering approach and established integrated technical plans across the Program elements to achieve the Program goals. The Program has also developed its integrated baseline which links the platform-based project activities with the resource-based pathway milestones, illuminating gaps/issues in the current project portfolio and pathway approach, and providing the foundation for data-driven decision-making by the Program management.

The Program uses additional systems engineering approaches including interface management, independent performance verification and robust information management tools to monitor overall progress on the pathways toward achieving technical goals. The integrated baseline is updated annually at a minimum, using project data and information. The updates monitor risks to delivering pathway goals and identify critical technical gaps, cost overruns and schedule slippages.

Peer Reviews

The Biomass Program implements the peer review process through a combination of subprogram element peer reviews and a program peer review conducted at least biennially. The emphasis of the program peer review is on the plan and the portfolio as a whole to determine whether or not it is balanced, organized, and performing appropriately. In contrast, the emphasis of the subprogram element reviews is on the projects in the element and whether or not projects are performing appropriately and contributing to element goals.

The Program peer review evaluates the RD&D subprogram element contribution toward the overall program goals as well as the processes, organization, management, and effectiveness of the Biomass Program. The review is led by an independent steering committee that selects independent experts to review both the Program and technical element portfolios. The results of the review provide the feedback on the Program performance and its portfolio, identifying opportunities for improved program management and gaps or imbalances in funding that need to be addressed. By addressing these gaps and imbalances, the Program will continue to stay focused on the highest priorities.

Subprogram element peer reviews are conducted prior to the Program review. Information and findings from the element peer reviews are incorporated into the Program peer review. The objectives of the subprogram element peer review meetings are as follows:

- Review and evaluate RD&D accomplishments and future plans of Program projects in a subprogram element following the process guidelines of the EERE Peer Review Guide,

and incorporating the project evaluation criteria used in the Program Stage Gate Management Process.³⁰

- Define and communicate Program strategic and performance goals applicable to the projects in the element.
- Provide an opportunity for stakeholders and participants to learn about and provide feedback on the projects in the Program portfolio and help shape the future efforts so that the highest priority work is identified and addressed.
- Foster interactions among industry, universities, and national laboratories conducting the RD&D, thereby facilitating technology transfer.

Technical experts from industry and academia are selected as reviewers based on their experience in various aspects of biomass technologies under review. The reviewers score and provide qualitative comments on the R&D based on the presentations given at the meeting and the background information provided. They are also asked to identify the specific strengths, weaknesses, technology transfer opportunities and recommendations for modifying project scope.

The Program analyzes all the information gathered at the review and develops appropriate responses to the findings for each project. All of the information, including the Program response, is documented and published in a review report that is made available to the public through the Program website.³¹

General Program Evaluation Studies

The Biomass Program sponsors several activities and processes that are aligned with the program evaluation studies described in the EERE Guide for Managing General Program Evaluation Studies. The Program is conducting general program evaluations based on this guide, including those listed below.

- Needs/Market Assessment Evaluations
- Outcome Evaluations
- Impact Evaluations
- Cost-Benefit Evaluations

Needs/Market Assessment Evaluations: The Biomass Program has held a number of workshops over the last few years that have brought together stakeholders from federal and state government agencies, industry, universities, trade associations, and environmental organizations to identify the key needs and opportunities for bio-based fuels and products in the U.S. including:

- *30 x 30 Industry Workshop (August 2006):* Invited industry, academic and other external experts in feedstock, conversion technologies, policy, environmental and infrastructure topics to provide independent input regarding key needs to meet the BFI goals.
<http://30x30workshop.biomass.govtools.us/default.aspx>

³⁰ Stage Gate Management in the Biomass Program, (Revision 2, February 2005). <http://devafdc.nrel.gov/pdfs/9276.pdf>, accessed 10/11/06.

³¹ Recent element review websites include: Products: <http://www.productstagegate.biomass.govtools.us/>, Sugar (Pretreatment/Hydrolysis): http://www.eere.energy.gov/biomass/progs/biogeneral/obp_gate/pehindex.html, Thermochemical Conversion: http://www.eere.energy.gov/biomass/progs/biogeneral/obp_gate/tcindex.html, Feedstocks: <http://feedstockreview.ornl.gov/>.

- *Regional Feedstock Partnership Workshop (2006)*: Participants from universities, State organizations, trade associations, DOE and USDA discussed opportunities for collaborative research that will facilitate the development of regional biomass resources.
- *Biomass R&D Technical Advisory Committee Roadmap Meetings (2006)*: Series of meetings across the country to collect input regarding biomass research and policy needs for consideration in revision of 2002 R&D Roadmap for Biomass Technologies in the United States. <http://brdisolutions.com>
- *DOE's Office of Science Biomass to Biofuels Workshop (December 2005)*: Joint DOE Planning Workshop brought together the DOE Offices of Science, Biological & Environmental Research, and EERE, along with EERE's Biomass Program to define how work at the frontiers of science can enable the lignocellulose biorefinery industry, identify technology opportunities and barriers. <http://genomicsgtl.energy.gov/biofuels/b2bworkshop.shtml>
- *DOE – The Biomass Program Permitting Meeting (2006)* <http://biofuelsstandards.biomass.govtools.us>
- *DOE – The Biomass Program Deployment Meeting (2005)*: The Biomass Program meeting with representatives from the private and public sectors, including finance, policy, industry, and engineering, to identify governmental actions that could effectively overcome the non-technical barriers and bridge the gaps between R&D and the deployment of new technology.

Additionally, the Program initiated an independent assessment of all R&D efforts (both DOE and non-DOE) to understand current technology development for biomass conversion to fuel ethanol. The assessment will identify projects that are making good progress toward the goals, those that need help, and those that are not contributing. Phase II will include analysis on the data collected and identify technology development gaps. Finally, the path to commercialization will be developed. The task final report will combine that assessment with deployment requirements and best practices to identify what needs to be done to meet the Program's goals for biofuels deployment.

Outcome, Impact and Cost/Benefit Evaluations: These types of evaluations are carried out by PBA and are described in the Benefits Analysis portion of section 2.2.1.

Technical Program Reviews

The Biomass Program uses several forms of technical review to assess progress and promote Program and project improvement: Biomass R&D Technical Advisory Committee program reviews; EERE strategic program reviews; and technical project reviews according to the Biomass Program Stage Gate management process.

The Biomass Technical Advisory Committee reviews the joint USDA and DOE/Biomass R&D portfolio annually and provides advice to the Secretaries of Energy and Agriculture concerning the technical focus and direction of the portfolios. The most recent report to Congress by the Committee³² includes a summary of their FY 05 review. Internally, DOE-EERE senior management holds periodic strategic program review meetings with the Biomass Program

³² Annual Report to Congress on the Biomass Research and Development Initiative for 2005, <http://www.biomass.govtools.us/pdfs/BiomassInitiativeReporttoCongressFY05063006.pdf>. downloaded 10/11/06.

Manager for various purposes, including preparation for Congressional budget submission and evaluation of strategic direction.

Technical Project Reviews

The Program also holds stage gate reviews at the project level. The stage gate process, as depicted in Figure 2.7, is an approach for making disciplined decisions about research and development that lead to focused process and/or product development efforts.³³ Specifically, the Program uses it to guide decisions on which projects to include in the Program's portfolio; align R&D project objectives with Program objectives and industry needs; provide guidance on project definition including scope, quality, outputs and integration; and review projects to evaluate progress and alignment with the Program portfolio.

Stage Gate Reviews: Each stage is preceded by a decision point or gate which must be passed through before work on the next stage can begin. Gate reviews are conducted by a combination of internal management and outside experts or the gate-keepers. The purpose of each gate is two fold: first the project must demonstrate that it met the objectives identified in the previous gate and stage plan and second that it satisfies the criteria for the current gate. A set of seven types of criteria are used to judge a project at each gate:

- Strategic Fit
- Market/Customer
- Technical Feasibility and Risks
- Competitive Advantage
- Legal/Regulatory Compliance
- Critical Success Factors and Show Stoppers
- Plan to Proceed

Specific criteria are different for each gate and become more rigorous as the project moves along the development pathway.

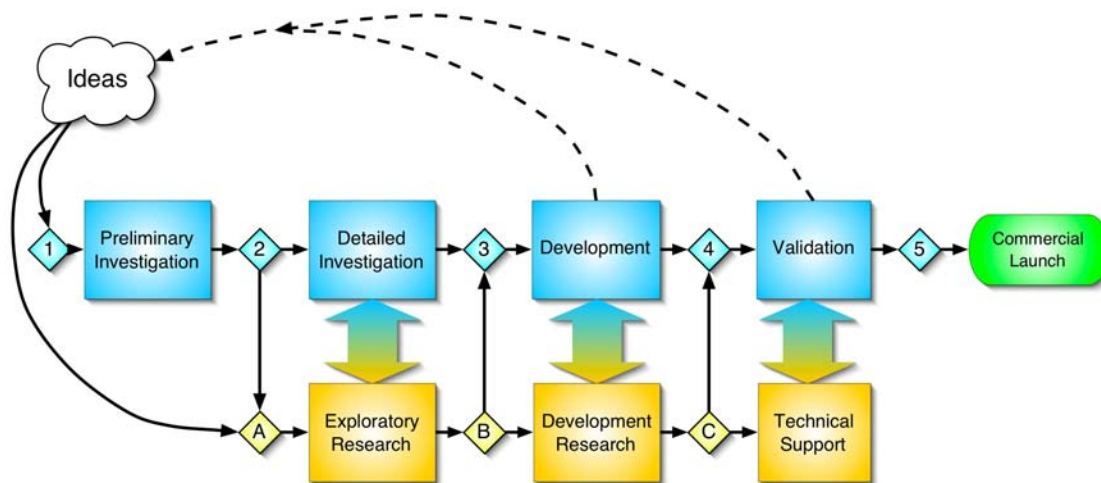

Figure 2-7: Biomass Program Stage Gate Process

³³ Stage Gate Management in the Biomass Program, (Revision 2, February 2005) is a guide to the process used by the Program., <http://devafdc.nrel.gov/pdfs/9276.pdf>, accessed 10/11/06.

The possible outcomes of this portion of the review could be pass, recycle, hold, or stop. Passing implies that the goals for the previous stage were met and everything looks good, including the market and customers and the projected economics. Recycling indicates that working longer in the current stage is justified; all goals have not been accomplished, but the project still has a high priority and potential looks promising. Hold suspends a project because the need for it may have diminished or disappeared. There is an implication that the market demand could come back and the project could be resumed later. Stopping a project might occur because the technology development is not progressing as it should, the market appears to have shifted permanently, the technology has become obsolete or the economic advantage is no longer there. In this case, the best ideas from the project are salvaged, but the project is permanently halted.

The second half of the gate review takes place if the decision is made that project "passes" the gate. The project leader must propose a project definition and preliminary plan for the next stage, including objectives, major milestones, high-level work breakdown structure, schedule, and resource requirements. The plan must be presented in sufficient detail for the reviewers to comment on the accomplishments necessary for the next stage and goals for completion of the next gate. Once the plan is accepted, the project can move to the next stage. Since the stakes get higher with each passing stage, the decision process becomes more complex and demanding. If the decision is made to "recycle" the project, the review panel will provide suggestions to the project leader on work that needs to be completed satisfactorily before the next gate review is held. In case of "hold" or "stop" decision, the plan to proceed is not needed.

An overview of the Biomass Program stage gate process is available online at <http://devafdc.nrel.gov/pdfs/9276.pdf>. The stage gate process is a key portfolio management tool because it integrates a number of key decision areas, all of which are challenging: project selection and prioritization, resource allocation across projects, and implementation of business strategy. The gates and gate reviews allow the Program to filter poor performing or off the target projects and reallocate resources to the best projects and/or open way for new projects to begin.

Section 3: Program Technology Research, Development & Deployment Plan

The Biomass Program’s research, development and deployment (RD&D) efforts are organized around four key technical elements – feedstock core R&D, conversion core R&D, integrated biorefineries, and biofuels infrastructure (Figure 3-1), and one non-technical element – crosscutting market transformation. The first two technical Program elements focus on core R&D activities, while the remaining two focus on demonstration and deployment activities. The non-technical element focuses on overcoming market barriers that could slow or even prevent full market penetration of biomass technologies. This organization of the work allows the Program to allocate resources for pre-commercial, enabling technology development, as well as for demonstration and deployment of technologies across the biomass to biofuels supply chain.

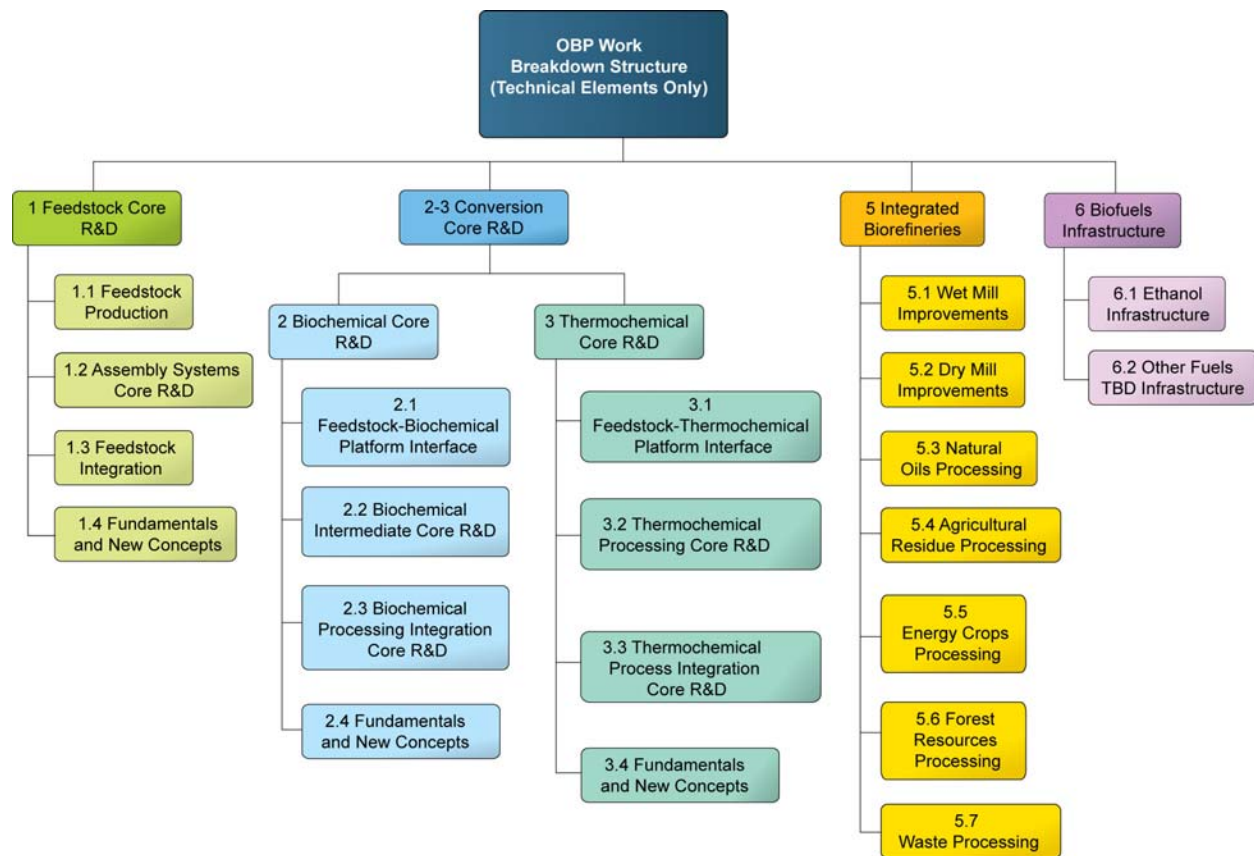

Figure 3-1: Biomass Program Work Breakdown Structure (Technical Elements Only)

Program Work Breakdown Structure

Core Research and Development

The core R&D sponsored by the Program is focused on understanding the technical barriers, providing engineering solutions and developing the scientific and engineering underpinnings of a bioindustry. Near- to mid-term applied R&D is focused on moving current feedstock and conversion technologies from concept to bench to integrated pilot scale. The goal of longer-term fundamental R&D is to develop basic knowledge of biomass, biological systems and

biochemical and thermochemical processes that can ultimately be used to develop new or improved technologies that increase the conversion efficiency and/or reduce the conversion cost. Core R&D is performed by national laboratories, industry and universities.

The Program core R&D includes two technical elements:

- **Feedstock Core R&D** is focused on developing sustainable technologies to provide a reliable, affordable and sustainable cellulosic biomass supply, in partnership with the U.S. Department of Agriculture (USDA) and DOE’s Office of Science (SC). The Program’s primary focus is on feedstock logistics – harvesting, storage and transportation. (For details, see section 3.1)
- **Conversion Core R&D** is focused on developing technologies to convert lignocellulosic feedstocks into cost-competitive liquid transportation fuels as well as bioproducts and biopower. Biochemical conversion efforts focus on producing sugars from biomass and fermenting those sugars to fuels or chemicals. Thermochemical conversion work is focused on producing intermediates via gasification, pyrolysis and other chemical means from biomass and organic biorefinery residues, and converting these intermediates into fuels, chemicals, or power. (For details, see section 3.2)

Technology Demonstration and Deployment

The Biomass Program’s demonstration and deployment activities focus on moving technologies beyond bench scale to pre-commercial demonstration and pioneer biofuels production plants, and facilitating introduction and expansion of biofuels distribution infrastructure and biofuels-compatible vehicles across the U.S. into the marketplace. These demonstration and deployment efforts directly align with the biomass-to-biofuels supply chain, as illustrated in Figure 3-2.

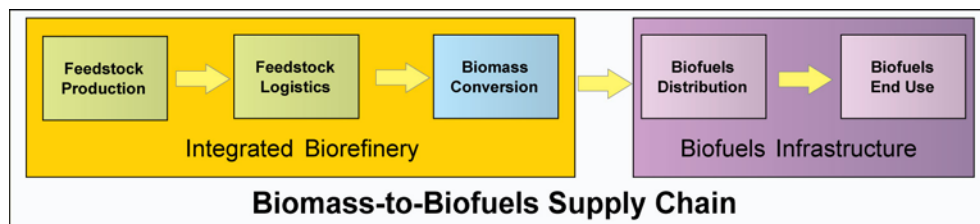

Figure 3-2: Scope of Program’s Demonstration and Deployment Efforts

The ultimate goal is to develop the supporting infrastructure needed to enable a fully developed and operational biomass-to-biofuels supply chain, in support of the Program’s 2030 goal.

Demonstration and deployment is conducted via Program partnerships with industry and other key stakeholders and includes two technical elements:

- **Integrated Biorefinery** activities focus on demonstration and deployment of large-scale integrated feedstock production, feedstock logistics and conversion processes that demonstrate and validate achievement of commercially acceptable cost and performance targets. These are industry-led, cost-shared, competitively awarded projects. Intellectual property and geographic and market factors will determine the feedstock and conversion technology options that industry will choose to demonstrate and commercialize. Government cost share of the final integrated stages of biorefinery development is essential due to the high technical risk and capital investment. Additionally, the Program will fund a number of pre-commercial (10 percent scale) demonstration- and commercial-

scale pioneer biofuels production facilities over the next few years (see section 3.3).

- **Biofuels Distribution Infrastructure and End Use** activities focus on coordinating with other federal agencies to develop the required biofuels distribution and end use infrastructure. This will include evaluating the performance and materials, environmental, and health and safety impacts of intermediate ethanol blends (e.g. E15 and E20) and supporting growth of E85, where regionally appropriate (see section 3.4).

Market Transformation

Dramatic increase in the supply of renewable biofuels by 2017 will require significant and rapid changes in various sectors of our economy. The Program is facilitating these changes by engaging in a range of non-RD&D activities that aim to reduce market barriers across the supply chain and at each stage of development—from research and development through major market penetration.

Crosscutting market transformation activities can be grouped into three general categories: stakeholder communications and outreach, strategic partnerships, and government policy and regulation. Recognizing that a myriad of conditions and players affect both the supply and demand sides of the market, the Program focuses its efforts on those market elements that it can most readily influence.

The Program’s Biorefinery Pathways Framework Approach

The Program’s biorefinery pathways framework integrates efforts among the technical elements and aligns with the major existing and envisioned future bioindustry market segments. Figure 3-3 shows the relationships between the biorefinery pathways and the Program Work Breakdown Structure (WBS), highlighting the Program’s current priority pathways to cellulosic ethanol production: Corn Wet and Dry Grind Mill Improvements, Agricultural Residue Processing, Energy Crops, Forest Resources, and Waste Materials pathways.

The Program examines the biorefinery pathways and prioritizes and balances research, development and deployment activities to emphasize those pathways that are expected to have the greatest impact on achieving Program goals. Figure 3-3 shows the Program integration of core R&D and demonstration and deployment of integrated biorefineries that will use the broad range of biomass feedstocks and leverage the know-how, capabilities and infrastructure of the existing bioindustry.

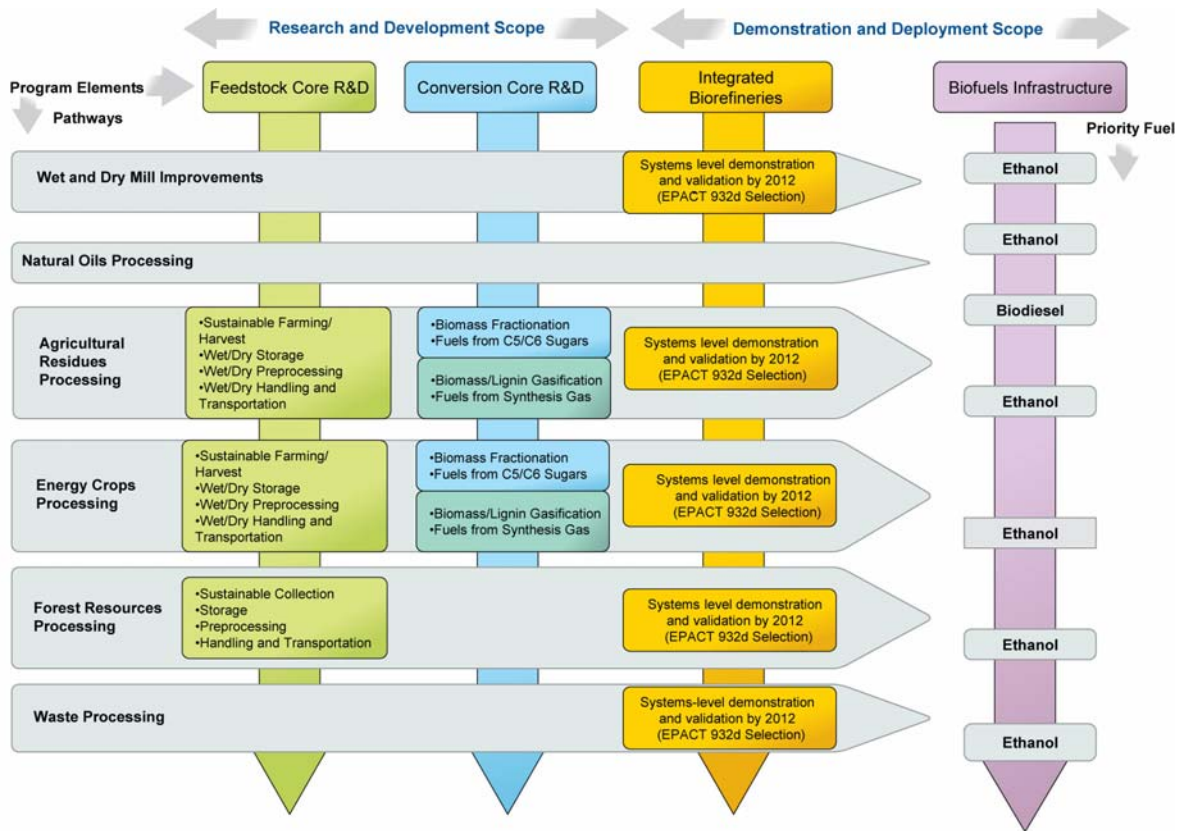

Figure 3-3: Program Technical Element Links to Biorefinery Pathway Framework

Premises for Program’s Biorefinery Pathway Framework

The Program biorefinery pathway framework was evolved to support the following needs:

- Recognize the diversity of feedstocks and their specific associated issues from production through conversion.
- Highlight the need for integration between the feedstock production, feedstock logistics and conversion elements of the overall biomass supply chain.
- Identify the complete set of technologies required up to and including those in the biorefinery and the connections, or interfaces, between the individual technology parts, especially those from fundamentally different technical areas or disciplines.
- Clarify how new technologies could fit into the existing bioindustry market segments.
- Identify current and future synergies within existing bioindustry market segments.
- Envision the transition from today’s bioindustry to the future.

The biorefinery pathways were charted in a manner so that they would

- link to specific portions of the resource base identified in the joint DOE/USDA Billion Ton Vision study;¹ and either

¹ Biomass as a Feedstock for a Bioenergy and Bioproducts Industry: The Technical Feasibility of a Billion-Ton Annual Supply, Robert D. Perlack, et al., USDA/DOE, DOE/GO-102005-2135, April 2005

- represent existing segments of today’s bio-industry where possible, or
- describe potential major future bio-industry market segments where envisioned.

Additionally, the pathways were designed keeping the following factors in mind:

- Specific enough to enable
 - creation of detailed RDD&D plans by giving technical context to performance metrics and cost targets, and
 - tracking of technological status and progress toward commercialization
- Flexible enough to be able to include new ideas and approaches as they are identified
- Generic enough such that combinations of pathways or pathway segments could be used to describe biorefineries
- Multiple levels of detail so that information could be rolled up or drilled down into depending on the need

Pathway Links to the Biomass Resource Base

Linking the biorefinery pathways to a biomass resource base bounds the total bioenergy potential from each source and helps to clearly identify the necessary R&D associated with feedstock production and logistics. It also guides prioritization so that the Program can focus on the feedstocks with the greatest impact on its goals.

The Billion Ton study describes the potential biomass supply that could be generated from U.S. agricultural and forestlands, as well as secondary and tertiary residues. The majority of the types of biomass resources described in the study are included as feedstocks to one of the seven pathways, as shown in Table 3-1. Figure 3-4 shows categories of feedstocks that led to the pathway definitions. However, there are some portions of the biomass resource base, such as animal manures, which do not currently have corresponding pathways defined in detail as they do not currently represent a significant portion of the overall Program investment and are covered by other federal efforts (most notably USDA and EPA).

Table 3-1: Feedstock Resources Allocated to Biorefinery Pathways

Pathway	Major Primary Feedstocks	Process Intermediates	Other Potential Primary Feedstocks	Other Waste Feedstocks
Wet Mill Improvements	Corn	Corn Fiber (Corn Gluten Feed)		
Dry Mill Improvements	Corn	DDGS	Sorghum Barley Wheat	
Natural Oils Processing	Soybeans	Glycerol	Other oil seed crops	Fats & Grease
Agricultural Residues Processing	Corn Stover Wheat Straw Rice Straw		Cereal Straws Soybean Residues Sugarcane Bagasse	
Energy Crop Processing	Switchgrass (as a model) Hybrid Poplar (as a model)		Other grasses Other trees	
Forest Resource Processing	Logging Residue Fuel Treatments Unutilized Conventional Wood	Bark/Hog Fuel Black Liquor Wood Resources		Wood Fiber
Waste Processing	Municipal Solid Waste Urban Wood Waste		Yard Waste Food Processing Waste	

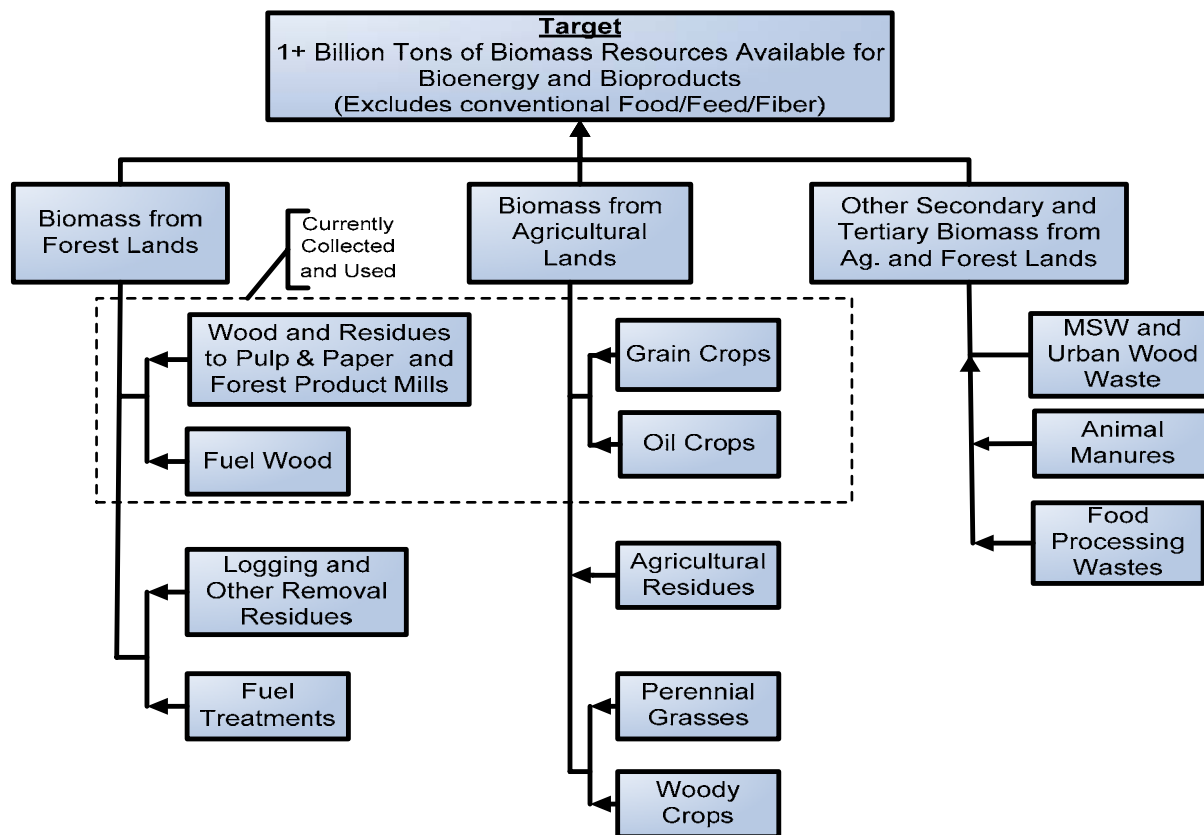

Figure 3-4: Biomass Resource Categories

Pathway Links to Bioindustry Market Segments – Current and Future

The existing bio-industry provides opportunities for public-private partnerships to integrate and demonstrate new technologies in commercial plants where the feedstock and infrastructure exists that could support incremental addition of new technologies (e.g., corn wet and dry grind mills, pulp and paper mills). These biorefinery pathways provide nearer-term opportunities to help achieve program goals. Efforts along these types of pathways serve a two-fold purpose, the first being the acceleration of technology deployment since deploying the technology into an existing infrastructure with a readily available feedstock lowers the cost and associated risk. The second benefit is reducing the time to build stand-alone plants. Integrating new technology into existing plants improves yield, efficiency and profitability, increasing the likelihood of finding commercial financing to enable the expansion of the domestic biofuels industry.

Agricultural residue and energy crop pathways require significant research and development in the areas of feedstock production, feedstock logistics and conversion technologies. While development time is longer for these options, their potential impact on displacing imported oil by producing biofuels is significantly larger.

Even though the Program has relatively limited effort in the existing corn wet mill and natural

oils processing pathways, the Program closely monitors industry growth of these market segments because they contribute to meeting the President’s “20 in 10” goal and use the same biofuels distribution and end use infrastructure that the other pathways will employ.

Program Element Discussion

The remainder of Section 3 details plans for each Program element:

FeedstockSection 3.1
ConversionSection 3.2
Integrated BiorefineriesSection 3.3
Biofuels InfrastructureSection 3.4
Crosscutting Market TransformationSection 3.5

Each element discussion is organized as follows:

- Brief overview of the element process concept and its interfaces with other elements of the program (in the context of biomass-to-biofuels supply chain)
- Element strategic goal, as derived from the Program strategic goals
- Element performance goals, as derived from the Program performance goals and biorefinery pathway milestones
- Technical and market challenges and barriers. Demonstration and deployment elements discussions include market barriers and are addressed in the Market Transformation element.
- Strategies for overcoming barriers, the basis for element work breakdown structures (tasks and activities with links to barriers)
- Milestones and decision-points

3.1 FEEDSTOCKS PLATFORM

The size of the U.S. bioindustry will, to a large degree, be determined by the quantity and quality of biomass available. As the starting material in the biomass-to-biofuels supply chain, sufficient and secure supply of affordable feedstocks is a critical step in accomplishing the Program goals. The Feedstock platform therefore relates strongly to all other facets of the program portfolio; it is, however, specifically linked to the Conversion platform as feedstock is the substrate for conversion technologies.

The Feedstock platform core R&D supports the first two elements of the biomass supply chain (Figure 1-1): feedstock production and feedstock logistics. Feedstock production includes all the steps required to sustainably produce biomass feedstocks to the point they are ready to be collected or harvested from the field or forest. Focusing on optimizing feedstock production regionally, the Biomass Program has implemented the Regional Feedstock Partnership with the USDA and land grant universities. The Partnership is dedicated to improving the assessment and sustainable development of feedstocks in each region. The Program is also coordinating with DOE laboratories, USDA land grant universities, and others to develop a fully integrated, national scale, geographic information system based framework to assist in the analysis, planning, and development of the nation's feedstock resources and biofuels infrastructure.

The Program coordinates with the DOE Office of Science (SC) on advanced feedstock production R&D. The SC Joint Genomes Institute under the Genomes-to-Life Program sequences plant species of interest to the Program, USDA, and the Regional Feedstock Partnership. SC and USDA Cooperative State Research Education and Extension Service (CSREES) also conduct an annual solicitation on feedstock genomics. SC supports basic research through its Bioenergy Centers to accelerate basic research in the development of cellulosic ethanol and other biofuels. The Biomass R&D Board has also commissioned an interagency feedstock working group to improve coordination between DOE (EERE and SC), USDA (multiple agencies), EPA, and other agencies. Currently, feedstock sub-groups have been organized for feedstock economics, sustainability, and greenhouse gases.

Feedstock logistics encompasses all the unit operations necessary to move biomass feedstocks from land to the biorefinery and to ensure that the delivered feedstock meets the specifications of the biorefinery conversion process. The Program's feedstock logistics R&D is focused on developing and optimizing cost-effective integrated systems for collecting, storing, preprocessing and transporting a range of potential lignocellulosic feedstocks, including agricultural residues, forest resources and dedicated energy crops.

As shown in Figure 3-5, Feedstock platform emphasis is on the feedstock logistics portion of the supply chain. Details of the process steps and associated issues are available in a recent roadmap document.²

² Hess, J.R.; Cushman, J.H.; Easterly, J.L.; Erbach, D.C.; Foust, T.D.; Graham, R.; Hettenhaus, J.R.; Hoskinson, R.L.; Perlack, R.D.; Sheehan, J.J.; Sokhansanj, S.; Tagore, S.; Thompson, D.N.; Turhollow, A.; Wright, L.L. (2003). Roadmap for Agricultural Biomass Feedstock

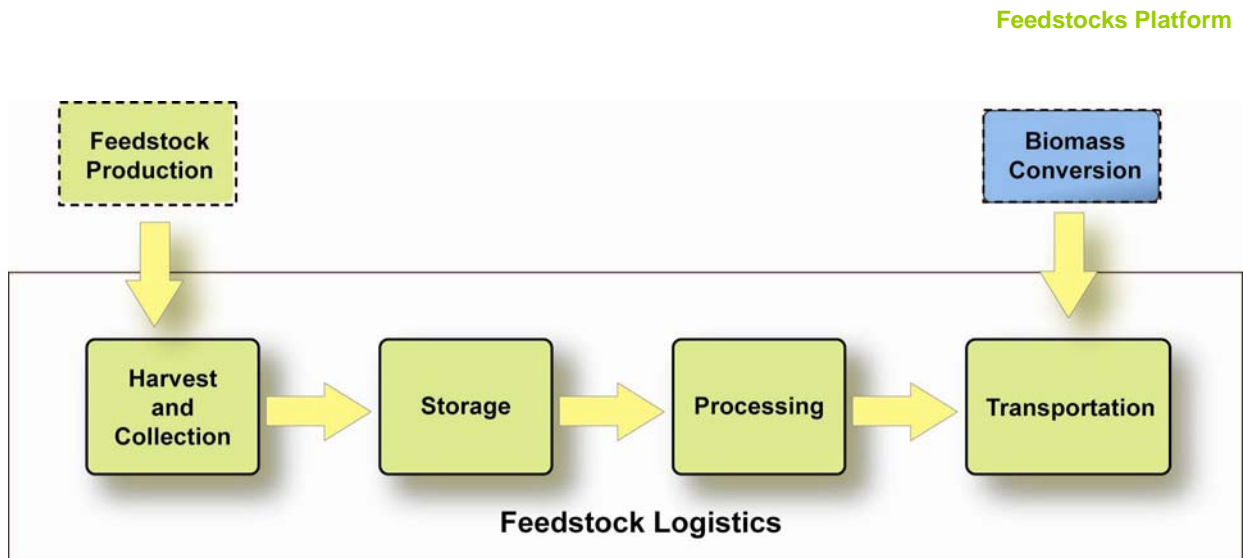

Figure 3-5: Feedstocks Platform Flow Chart

In order to accommodate the significant differences in feedstock characteristics, logistics systems will be designed and validated for four feedstock sub-classes:

- Dry herbaceous (<20% moisture content and includes cereal straw and switchgrass),
- Wet herbaceous (>40% moisture and includes corn stover and sorghum stover),
- Woody (about 50% moisture and includes logging residues, forest thinnings and plantation tree crops), and
- Emerging high tonnage, non-conventional energy crops (includes sugar cane, miscanthus, and high-yield switchgrass stands)

3.1.1 FEEDSTOCK SUPPORT OF BIOMASS PROGRAM STRATEGIC GOALS

The Biomass Program’s overarching strategic goal is to *develop sustainable, cost-competitive biomass technologies to enable the production of biofuels nationwide and reduce dependence on oil through creation of a new domestic bioindustry supporting the President’s goal to reduce gasoline use 20 percent by 2017.*

Biomass feedstocks are essential to achieving this goal as they are the basis on which all other program platforms rely. The cost, quantity and quality of feedstock available will determine the amount of biofuels that can be produced. The Feedstock platform strategic goal is to *develop sustainable technologies to provide a secure, reliable and affordable cellulosic and sustainable biomass feedstock supply for the U.S. bioindustry in partnership with USDA and other key stakeholders.* The ultimate outcome (2030 and beyond) of the Feedstock platform is technology and methods that can supply over 1 billion tons per year of biomass feedstocks in a sustainable and cost-effective manner.

The Feedstock platform directly addresses and supports production and harvesting of feedstocks in the Agricultural Residues, the Energy Crops, and the Forest Resources pathways.

3.1.2 FEEDSTOCK SUPPORT OF BIOMASS PROGRAM PERFORMANCE GOALS

The Feedstock platform has two high-level performance goals, one for production and another for logistics. The feedstock production goal is to validate that a sustainable high-quality accessible feedstock supply of 130 million dry tons per year would be available by 2012, growing to 250 million dry tons per year by 2017. This goal is necessary to spatially quantify the accessible resource and validate the percentage of the resource that could be recovered cost effectively. The platform's strategy for meeting this goal is described in section 3.1.4.

The feedstock logistics goal is to reduce the feedstock logistics cost to \$0.37 per gallon of ethanol (equivalent to approximately \$33/dry ton in 2007 \$) by 2012, with further reduction to \$0.33 per gallon of ethanol by 2017. Cost saving and process improving technologies will be developed within each stage of the feedstock supply chain (Figure 3-4). The logistics goal applies to the dry herbaceous, wet herbaceous and woody feedstock types. The platform's strategy for meeting this goal is described in sections 3.1.4 and 3.1.5.

The specific pathway goals under investigation are:

Agricultural Residues Processing Pathway

- By 2009, validate integrated feedstock logistics for dry corn stover in prototype equipment
- By 2009, validate integrated feedstock logistics for dry wheat straw in prototype equipment
- By 2012, validate integrated feedstock logistics for wet corn stover in prototype equipment

Energy Crops Processing Pathway

- By 2009, validate integrated feedstock logistics for dry switchgrass in prototype equipment
- By 2011, validate integrated feedstock logistics for woody energy crops in prototype equipment
- By 2012, validate integrated feedstock logistics for wet switchgrass silage in prototype equipment

Forest Resources Pathway

To be determined as forest biomass R&D priorities are identified in consultation with stakeholders.

3.1.3 FEEDSTOCK TECHNICAL CHALLENGES AND BARRIERS

Feedstock Production Technical Barriers

Ft-A. Resource Availability and Cost: The lack of credible data on price, location, quality and quantity of biomass creates uncertainty for investors and developers of emerging biorefinery technologies. In addition to a lack of information regarding national cellulosic biomass production, current estimates of feedstock resources are limited in scope, and do not consider how major technological advantages in production technologies will impact biomass availability.

Due to the diversity and wide distribution of biomass feedstock resources, a regional approach is required to complete a more detailed assessment of the resources initially identified in the Billion Ton study. Feedstock supply is a significant cost component of bio-based fuels, products, and power.

Ft-B. Sustainable Production: Existing data on the environmental effects of feedstock production and residue collection are not adequate to support lifecycle analysis of biorefinery systems. The lack of information and decision support tools to predict effects of residue removal as a function of soil type, and the lack of a selective harvest technology that can evenly remove only desired portions of the residue make it difficult to assure that residue biomass will be collected in a sustainable manner. Until the residue issue is addressed, particularly with regard to corn stover, deployment of the Agricultural Residue pathway will be severely constrained. The production and use of energy crops also raise a number of sustainability questions (such as water and fertilizer inputs, establishment and harvesting impacts on soil, etc.) that have not been comprehensively addressed.

Ft-C. Crop Genetics: Current crops and potential new crops require improvement to achieve the production potential estimates of the billion ton vision. There is inadequate information on plant biochemistry as well as insufficient genomic and metabolic data on many potential biomass crops. Genetic modification of energy crops for improved characteristics may create risks to native populations of related species, and any modification of commodity crops to improve residue characteristics may affect grain values.

The Feedstock Platform's strategy for addressing feedstock production technical barriers is described in Section 3.1.4.

Feedstock Logistics Technical Barriers

Ft-D.³ Sustainable Harvest: Current crop harvesting machinery is unable to selectively harvest desired components of biomass and address the soil carbon and erosion sustainability constraints. Biomass variability places high demand and functional requirements on biomass harvesting equipment. Current systems cannot meet the capacity, efficiency, or delivered price requirements of large cellulosic biorefineries, nor can they effectively deal with the large biomass yields per acre of potential new biomass feedstock crops. In addition, feedstock specifications and standards against which to engineer harvest equipment, technologies, and methods, do not currently exist.

Ft-G. Feedstock Quality and Monitoring: Physical, chemical, microbiological, and post-harvest physiological variations in feedstocks arising from differences in variety, geographical location, and harvest methods are not well understood. Passive, noninvasive analytical tools and sensors for rapid and/or real-time compositional and conversion efficiency measurements for cellulosic feedstocks are needed. In addition, processor standards and specifications for feedstocks are not currently available.

³ Barrier Ft-E. Engineering Systems from previous MYPP was combined into Ft-D.

Ft-H.⁴ Storage Systems: Engineering analysis of unconventional storage methods, including centralized versus distributed systems, is needed to define storage requirements. Key elements requiring better understanding include in storage biomass losses, infrastructure for packaged (i.e., bale, silage wrap, etc.) and bulk stored biomass, storage bulk density, and post-harvest physiology of storage systems. These storage elements need to be understood as a function of feedstock source, biomass moisture, climate, storage time, and cost. Stored biomass that is or becomes wet is susceptible to spoilage, rotting, spontaneous combustion, and odor problems, therefore, the impact of these post-harvest physiological processes must be controlled to the benefit of biorefining processes.

Ft-J. Biomass Material Properties: Data on biomass quality and physical property characteristics for optimum conversion are limited. Information on functional moisture relations on quality and physical properties of biomass as affected by crop variability and climatic conditions during harvest and post-harvest operations is incomplete. Methods and instruments for measuring physical and biomechanical properties of biomass are lacking.

Ft-K. Biomass Physical State Alteration (i.e., grinding, densification, and blending): The initial sizing and grinding of biomass affects efficiencies and quality of all the downstream operations, yet little information exists on these operations with respect to the multiplicity of cellulosic biomass resources and biomass format requirements for biorefining. New technologies and equipment are required to process biomass between the field and conversion facilities. The harvest season for most crop-based cellulosic biomass is short, especially in northern climates, thus requiring preprocessing systems that facilitate stable biomass storage, densification, and blending for year-round feedstock delivery to the biorefinery.

Ft-L.⁵ Biomass Material Handling and Transportation: The capital and operating costs for the existing package-based (i.e., bales, modules, pellets, etc.) equipment and facilities do not meet cost targets. The low density and fibrous nature of cellulosic biomass make it difficult and costly to collect, handle and transport. Present methodologies for collecting, storage handling, transport, and in-biorefinery handling of the biomass are too costly and inefficient for handling million ton quantities of biomass in a manner compliant with the efficiency and permitting requirements of cellulosic biorefineries.

Ft-M. Overall Integration: Existing biomass collection, handling, and transport systems are not designed for the large-scale needs of integrated biorefineries. Feedstock logistics infrastructure has not been defined for various locations, climates, feedstocks, storage methods, etc. The lack of experience with integrating time-sensitive collection, storage, transportation and delivery operations to ensure year-round supply of large amounts of biorefinery feedstock is a barrier to widespread implementation of biorefinery technology. The lack of data on variability of biomass resources and how this variability affects shelf life and processing yields are further barriers. In addition, it may be possible to better integrate one or more aspect of the feedstock supply system

⁴ Barriers Ft-I. Wet Storage Systems and Ft-H Dry Storage Systems from previous MYPP were combined and renamed “Storage Systems”

⁵ Barrier Ft-F. Bulk Handling Equipment Limitations from previous MYPP was combined into Ft-L.

either alone or in combination with biorefinery operations. The lack of a quantitative analysis that assesses the benefits and drawbacks of these potential integration options is a potential barrier to cost savings and biorefinery efficiency improvement.

The Feedstock platform’s strategy for addressing feedstock logistics technical barriers is described in section 3.1.4, while their prioritization is explained in section 3.1.5.

3.1.4 FEEDSTOCKS PLATFORM APPROACH FOR OVERCOMING CHALLENGES AND BARRIERS

The Feedstock platform approach for overcoming feedstock supply challenges and barriers is outlined in its work breakdown structure (WBS). Organized around four key tasks as shown in Figure 3-6, the approach includes partnerships with USDA, DOE Office of Science, Sun Grant Initiative universities, a variety of regional partners, industry, and national laboratories. National laboratories, industry and universities perform core research projects which address the key technical barriers and are targeted to accomplish specific technical objectives.

The current feedstock production efforts are focused on 1) establishing regional partnerships for leveraging funding support for resource assessment and sustainability issues, and 2) establishing a GIS atlas to serve as a tool in resource assessment and biofuels production facility siting.

The current feedstock logistics efforts are focused on 1) feedstock quality, consistency, and processing costs associated with harvesting and collection, preprocessing, and storage, and 2) fundamental research on improving feedstocks for biofuels production.

Analysis is used to focus efforts on overcoming technical barriers that have the greatest impact on achieving strategic and performance goals.

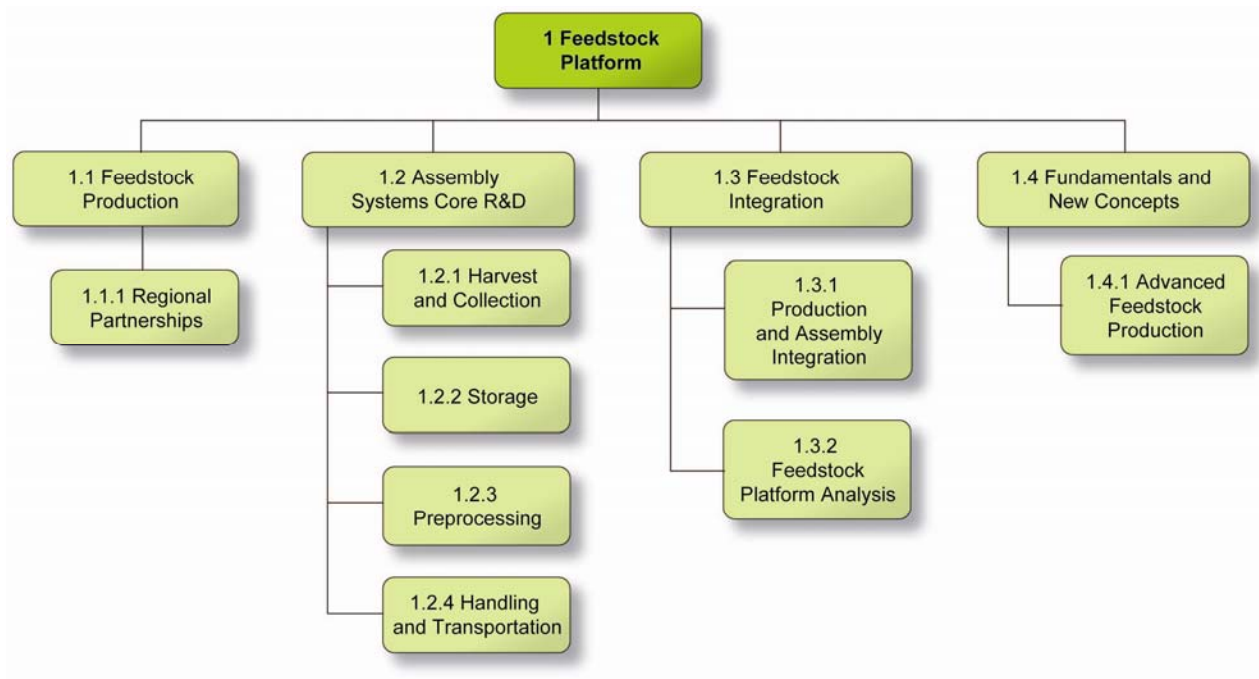

Figure 3-6: Feedstocks Platform WBS

The R&D approach of each WBS task element is described below, while Table 3-2 summarizes each task element's work as it relates to specific barriers and biorefinery pathways.

WBS 1.1 Feedstock Production

[Barriers: Resource Availability and Cost (Ft-A), Sustainable Production (Ft-B), and Crop Genetics (Ft-C)]

Efforts to overcome feedstock production barriers to enable an adequate, sustainable, and cost-effective supply of feedstocks to biorefineries are implemented through the establishment of Regional Biomass Feedstock Partnerships (RBFP) in conjunction with the Sun Grant Initiative, and collaboration among the RBFP, national laboratories, DOE, and USDA.

To address the Resource Availability and Cost barrier, ORNL is revising the Billion Ton study and developing supply curves. ORNL, INL, and the RBFP are compiling a GIS database ("GIS Atlas") that can be used in biorefinery siting studies and will be used to refine regional supply curves.

To address the Sustainable Production barrier, data in the GIS Atlas can be used to examine issues related to sustainable biomass feedstock production, such as soil erosion, soil organic matter, and water quality. As part of the RBFP effort, a tool is being developed in conjunction with INL and USDA/ARS to estimate soil erosion from corn residue removal. Replicated field trials are being established to determine the impact of residue removal and validate the residue removal tool. While residues are a significant source of feedstock, a larger potential source is dedicated herbaceous and woody energy crops grown on cropland and biomass harvested from CRP and existing pastures.

The primary focus of the RBFP is crop development, primarily perennial herbaceous and woody crops, although some annual crops such as sorghum will also be developed. This will address the Crop Genetics barrier. Crop development is a multi-year effort, focusing on increasing yields and improving growth and conversion characteristics. Replicated field trials are necessary to evaluate and demonstrate improved energy crops. Trials are regionalized because of the varying growing conditions among regions and their suitability to different feedstocks.

WBS 1.2 Assembly Systems Core R&D

[Barriers: Sustainable Harvest (Ft-D), Feedstock Quality and Monitoring (Ft-G), Storage Systems (Ft-H), Biomass Material Properties (Ft-J), Biomass Physical State Alteration (Ft-K), and Biomass Material Handling and Transportation (Ft-L)]

Efficient linkage between feedstock production and conversion processes is critical. In agriculture, traditional technologies used for feedstock assembly have typically served the smaller distributed livestock and forage industry. The forest products industry operates pulp and paper mills the size of envisioned biorefineries. The feedstock assembly core R&D tasks focus on migrating feedstock assembly from the traditional systems to those specifically designed for the biorefinery industry and improving on the pulp and paper model.

New and improved concepts are being sought to consider as cost-effective alternatives to

traditional activities such as harvest, collection, preprocessing (e.g. size reduction, densification, fractionation), storage, and bulk handling. Optimal handling strategies vary by crop, geographic location, and conversion process. Bulk handling should migrate from discrete units (e.g. bales, modules) to semi-continuous or continuous flow of materials (e.g. granules). Storage options can range from centralized to distributed and multiple feedstock biomass streams that minimize storage. The systems will be developed to optimize transport weights and determine where preprocessing should take place. Noninvasive and nondestructive tools and sensors are needed.

Specifically, work will focus on: 1) In the nearer term, increasing the tonnage of readily available biomass feedstock at a lower cost through advances in supply system technologies to balance relatively high biomass conversion costs; 2) In a sustained longer term effort, increasing the quantity of more inherently costly biomass feedstocks, such as energy crops, which will generally demand a higher price that can be afforded due to a reduction in biomass conversion costs; and 3) Forming partnerships with competitively selected equipment manufacturers.

WBS 1.3 Feedstock Integration

[Barrier: Overall Integration (Ft-M)]

This WBS task closely relates to WBS 1.2. While individual modules of feedstock assembly can be optimized, feedstock integration efforts will ensure that it is the overall process leading to conversion that is optimized. This can partly be done through modeling efforts, but also requires larger-scale field trials from feedstock production through assembly and ultimately through conversion. Feedstock integration activities focus on ensuring that each of the operations in the feedstock portions of the overall biomass supply chain can work together seamlessly to optimally provide biomass to a biorefinery. The new feedstock system design concept effectively makes feedstock assembly an extension of the biorefinery, since the feedstock can now be formatted and fractionated to optimize conversion efficiencies as part of the assembly process.

WBS 1.4 Fundamentals and New Concepts

[Barrier: Crop Genetics (Ft-C)]

In order to achieve the large quantities of biomass needed in the long term, genomics and agronomics strategies are needed to maximize the biomass yield and to improve the quality of energy crops. Also design and manipulation of plant cell wall composition and structure is needed to maximize the yield of biofuels. In the near term, this work is expected to be funded by the DOE Office of Science (SC), however the Program will monitor and coordinate its activities with the DOE SC efforts.

Table 3-2: Feedstocks Platform Core R&D Task Summary

Platform Goal: <i>Develop new sustainable and cost-effective feedstock production and logistics technologies and methods to supply lignocellulosic feedstocks to future commercial-scale biorefineries.</i>			
Feedstocks Platform WBS Element	Description	Barriers Addressed⁶	Pathway(s) Addressed
1.1 Feedstock Production			
1.1.1 Regional Partnerships	<p>Establish regional feedstock partnerships to identify local opportunities for feedstock production and biofuels production, including ethanol.</p> <p>2007-2012</p> <ul style="list-style-type: none"> Assess cost and availability of feedstock resource on local basis. Identify regional tonnages of each feedstock resource. Define and validate sustainable agronomic activities specific to feedstock type and region. Develop GIS resource assessment tools to store, share and analyze information about the U.S. biomass resource base. <p>2013-2017</p> <ul style="list-style-type: none"> Develop region-specific perennial crop programs. 	<p>Ft-A: Resource Availability and Cost</p> <p>Ft-B: Sustainable Production</p> <p>Ft-C: Crop Genetics</p>	<ul style="list-style-type: none"> Corn Wet Mill Corn Dry Mill Natural Oils Processing Agricultural Residue Processing Energy Crops Processing Forest Resources Processing Waste Processing
1.2 Assembly Systems Core R&D			
1.2.1 Harvest and Collection	<p>Improve efficiency of feedstock harvesting and collection systems to reduce costs and increase available tonnages of biomass feedstock.</p> <p>2007-2012</p> <ul style="list-style-type: none"> Develop innovative harvest and collection methods that reduce unit operations and agronomic/operational impact for all feedstock types. Quantify and validate harvesting-specific quality requirements (e.g., composition, pretreatment, contaminants, and bulk handling). Develop and test innovative equipment specific to the recovery of wood resources for each class and condition in which existing equipment is too costly and inefficient. <p>2013-2017</p> <ul style="list-style-type: none"> Develop harvesting systems for new high yielding energy crops. 	<p>Ft-D: Sustainable Harvest</p> <p>Ft-G: Feedstock Quality and Monitoring</p> <p>Ft-J: Biomass Material Properties</p> <p>Ft-M: Overall Integration</p>	<ul style="list-style-type: none"> Agricultural Residue Processing Energy Crops Processing Forest Resources Processing
1.2.2 Storage	<p>Minimize negative impacts of feedstock storage systems.</p> <p>2007-2012</p> <ul style="list-style-type: none"> Assess storage options and impacts on dry matter losses, compositional changes, and functional biomass changes specific to resource type and region. Identify key cost, safety and infrastructure issues and develop paths to minimize industrial-scale storage costs. Understand soluble sugar and carbohydrate loss and evaluate the feasibility of preventing or reclaiming those soluble sugars and carbohydrates from the feedstock during storage. <p>2013-2017</p> <ul style="list-style-type: none"> Develop storage systems compatible advanced conversion systems (e.g. with in situ plant enzymes). 	<p>Ft-G: Feedstock Quality and Monitoring</p> <p>Ft-H: Storage Systems</p> <p>Ft-M: Overall Integration</p>	<ul style="list-style-type: none"> Agricultural Residue Processing Energy Crops Processing

⁶ see section 3.1.3 for description

<p>1.2.3 Preprocessing</p>	<p>Optimize/tailor preprocessing systems with respect to equipment capacity, bulk density and quality for each feedstock type and biorefinery configuration combination. 2007-2012</p> <ul style="list-style-type: none"> • Develop preprocessing requirements, based on biorefinery feedstock quality requirements, for each feedstock type. • Develop equipment and methods to meet preprocessing requirements for each resource type. • Optimize grinder configuration for fractionation, capacity, and efficiency. • Develop innovative bulk compaction methods that control biomass deconstruction and produce desired rheological properties. • Understand and control pre-processed feedstock rheological properties to provide a product that minimizes problems in transportation, handling, and queuing operations. <p>2013-2017</p> <ul style="list-style-type: none"> • Develop preprocessing and advanced biomass fractionation blending systems to maximize biomass market value and product uniformity to biorefineries. 	<p>Ft-G: Feedstock Quality and Monitoring; Ft-J: Biomass Material Properties Ft-K: Biomass Physical State Alteration (grinding, densification, etc.) Ft-M: Overall Integration</p>	<ul style="list-style-type: none"> • Agricultural Residue Processing • Energy Crops Processing
<p>1.2.4 Handling and Transportation</p>	<p>Optimize feedstock properties to minimize transportation costs. 2007-2012</p> <ul style="list-style-type: none"> • Optimize feedstock physical and rheological properties with respect to handling and transportation requirement. • Develop innovative handling methods to optimize transportation capacities. <p>2013-2017</p> <ul style="list-style-type: none"> • Develop advance handling and transport concepts, including slurry systems. 	<p>Ft-J: Biomass Material Properties Ft-L: Biomass Material Handling and Transportation Ft-M: Overall Integration</p>	<ul style="list-style-type: none"> • Agricultural Residue Processing • Energy Crops Processing
<p>1.3 Feedstock Integration</p>			
<p>1.3.1 Production and Assembly Integration</p>	<p>Define/coordinate/consolidate the interfaces between and within feedstock production and feedstock logistics. 2007-2012</p> <ul style="list-style-type: none"> • Validate integrated feedstock assembly system that meets capacity, bulk density, rheological properties, composition and quality requirements for dry agricultural feedstocks. <p>2013-2017</p> <ul style="list-style-type: none"> • Validate integrated feedstock assembly system that meets capacity, bulk density, rheological properties, composition and quality requirements for wet agricultural feedstocks. 	<p>Ft-M: Overall Integration</p>	<ul style="list-style-type: none"> • Agricultural Residue Processing • Energy Crops Processing
<p>1.3.2 Feedstock Platform Analysis</p>	<p>Develop and employ standard analysis tools to estimate current and future biomass feedstock supplies, cost and quality parameters with input from stakeholders. 2007-2012</p> <ul style="list-style-type: none"> • Develop credible, industry-accessible data on current and future feedstock supplies (type, price, quantity and location). • Develop optimized process and cost models for feedstock supply systems to analytically develop and validate technical targets. <p>2013-2017</p> <ul style="list-style-type: none"> • Develop credible analyses of the fraction of the total biomass resource that can be sustainably accessed and recovered for biorefining. 	<p>Ft-A: Resource Availability and Cost Ft-H: Storage Systems</p>	<ul style="list-style-type: none"> • Corn Wet Mill • Corn Dry Mill • Natural Oils Processing • Agricultural Residue Processing • Energy Crops Processing • Forest Resources Processing • Waste Processing

1.4 Fundamentals and New Concepts			
<p>1.4.1 Advanced Feedstock Production</p>	<p>Develop tools and strategies to improve biomass feedstocks for bioenergy production.</p> <p>2007-2012</p> <ul style="list-style-type: none"> • Develop genomics and agronomic strategies related to increasing the yield and improving the quality of developing energy crops to not only increase the total biomass resource base, but increase the fraction of that total resource base sustainably accessible for bioenergy. • Design and manipulate plant cell wall composition and structure to maximize the yield of fermentable sugars, including enzyme expression systems in plant cells. <p>2013-2017</p> <ul style="list-style-type: none"> • Demonstrate increased yield in selected energy crops. • Demonstrate cellulase expression in feedstocks. 	<p>Ft-B: Sustainable Production Ft-C: Crop Genetics Ft-M: Overall Integration</p>	<ul style="list-style-type: none"> • Agricultural Residue Processing • Energy Crops Processing • Forest Resources Processing

3.1.5 PRIORITIZING FEEDSTOCKS PLATFORM BARRIERS

Figures 3-7, 3-8, and 3-9 illustrate how the Feedstock platform utilizes analysis to prioritize efforts in overcoming technical barriers. Figure 3-7 shows the quantities of different feedstock types expected to be accessible at specific grower payments (see Appendix B, Table B-1 for details).⁷ Grower payments are those made to crop producers over and above those for harvest, collection, storage, preprocessing, and transport. For crop residues, these cover the value of the residue removed (e.g. nutrients, organic matter, hassle factor, and profit). These residue removal values in corn stover rise as fertilizer prices increase. Valuation of residue can be adjusted due to: 1) crop rotation (e.g. if nitrogen fixing soybeans follow corn and no value is given to the stover nitrogen content, then the nutrient value is approximately \$11/dry ton); 2) soil characteristics (e.g. stover removal in the fall on a heavier wet soil allows earlier planting in the spring and a higher yield the next year); and 3) field nutrient status (residue/nutrient removal may be desired by the producer if the grower is considering amending the soil with manure).

For dedicated energy crops, grower payments must cover land rents, pre-harvest machine costs, variable inputs such as fertilizers, and amortized establishment costs for perennial crops; the payments must reflect what profit the land could produce if planted with other crops. Other aspects affect grower payments, such as profits to growers for investment returns and risk taking, alternative financial arrangements (e.g., cooperatives), fixed pricing mechanisms, shared-equity arrangements between growers and processors, and other competitive uses. Growers and processors (biorefinery) may have conflicting objectives – growers trying to maximize price received and processors trying to minimize their cost of acquiring crops and residues. Greater understanding of alternative financial arrangements and ways that growers and processors can work cooperatively can lead to a greater sharing of risks and profits to the mutual satisfaction of all in the feedstock supply chain. Estimates for the grower payment for dedicated energy crops may range from \$10 to \$30 per dry ton.

The solid bars in Figure 3-7 represent the quantities of feedstock available without any improved agronomic or environmental factors or new crop enhancements. The bars in the chart with patterns show the additional quantities of feedstock that are expected to be available with improvements. Cereal straw is available today, but not currently used at the tonnages listed in biorefineries. Corn stover, cereal straw, woody biomass from logging residues, and fuel thinning operations on private lands are the three major feedstock categories in 2012. Additional corn stover and cereal straw, and some switchgrass could be available with improvements. By 2017, with improvements, the corn stover and woody biomass residues could nearly double, and switchgrass would overtake cereal straw as the third largest segment.

⁷ Corn stover, cereal straw and switchgrass quantities is based on preliminary updated information from R. Perlack on feedstock supply curve analysis in progress and scheduled for completion in Fall 2007. Forest residue information is consistent with assumptions from the Billion Ton study and may be a conservative estimate.

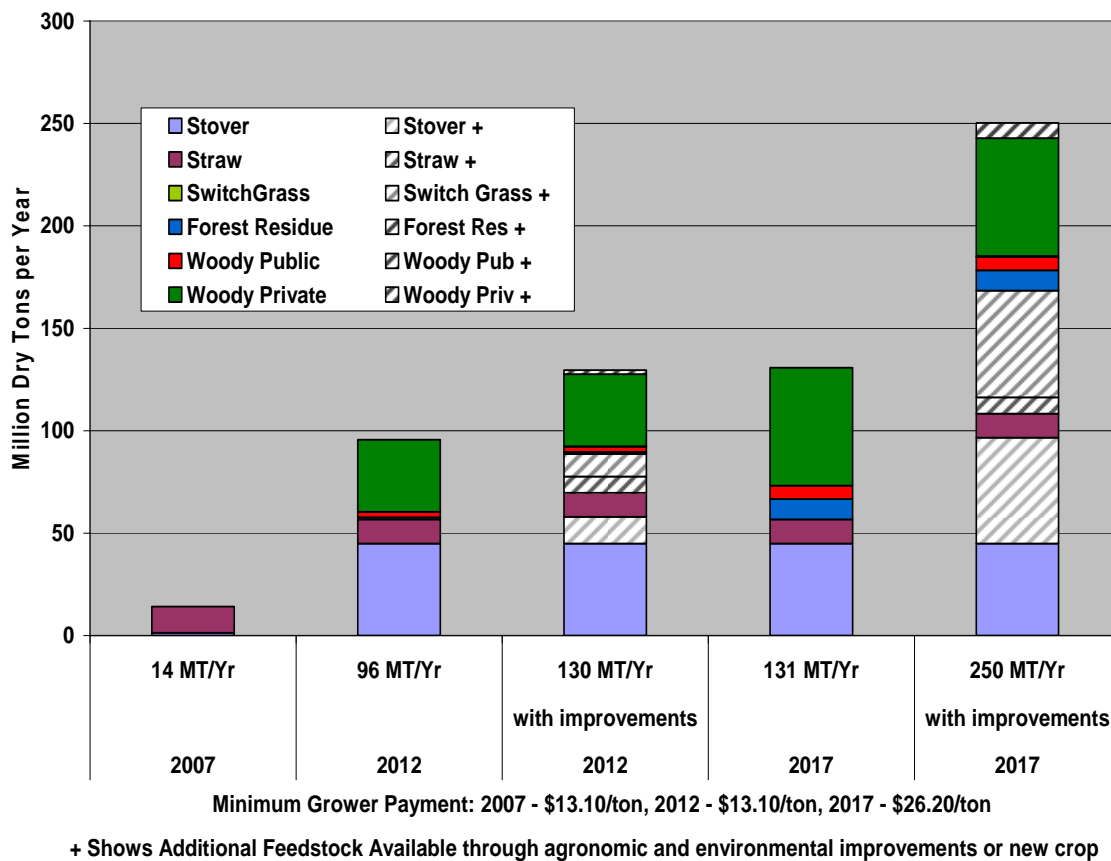

Figure 3-7: Feedstock Available at Specified Minimum Grower Payments

Feedstocks must be classified as wet or dry primarily to address storage quality issues (feedstock degradation). Moisture content also becomes an issue in weight-limited transportation modes (e.g. transport by trucks). A feedstock is considered dry if its moisture content is less than 20% and wet if its moisture content is greater than 40%.

Herbaceous feedstocks are typically greater than 50% moisture at time of harvest, and some feedstocks (e.g. switchgrass), under some climate conditions, will field dry to less than 20% moisture and be considered dry feedstocks. Thick-stemmed herbaceous feedstocks (e.g. sweet sorghum, energy cane) are typically 70% moisture at harvest and must be handled and stored as wet feedstocks. Woody feedstocks are typically about 50% moisture following harvest, and can be stored at this moisture content without degradation. Wet feedstocks can be artificially dried, but this is typically not cost effective unless an inexpensive energy source is available (e.g. waste heat from a conversion facility). The most convenient way of managing feedstocks between 20% and 40% moisture is to use them immediately upon harvest, thereby avoiding storage all together, or adding moisture until they behave as wet feedstocks (above 40% moisture content).

Figure 3-8 shows the magnitude of the potential reduction in the logistics costs for dry herbaceous feedstocks that can be obtained with technology development. Cereal straw, an estimated 10 percent of corn stover, and switchgrass, are expected to fall into this category. Table 3-3 provides detailed cost breakdown in both dollars per dry ton of feedstock delivered to

a biorefinery, as well as dollars per gallon of ethanol produced at a biorefinery, based on a specific ethanol yield.⁸ Figure 3-9 and Table 3-4 show similar information for wet herbaceous feedstocks (model feedstock: remaining 90 percent of corn stover). See Appendix B, Tables B-2 and B-3, for details on dry and wet herbaceous logistics costs and technical targets.

Figure 3-8: Dry Herbaceous Feedstock Logistics Costs

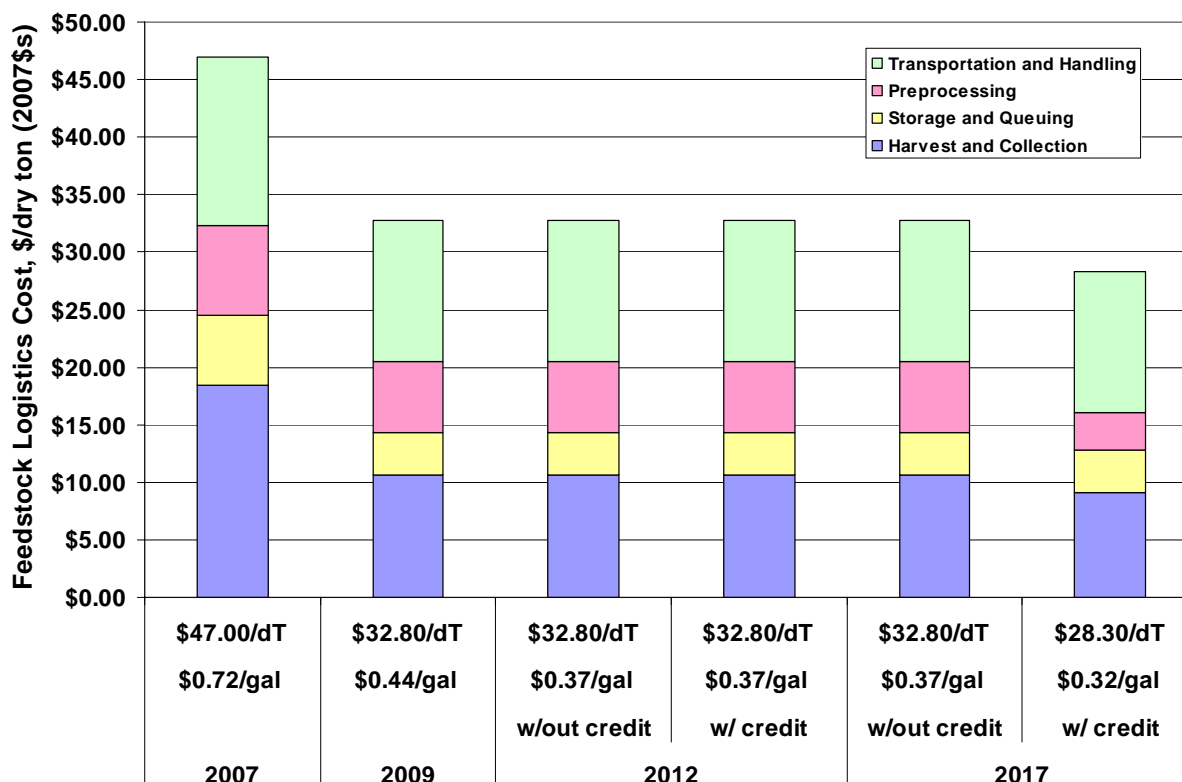

Table 3-3: Dry Herbaceous Feedstock Logistics Costs (2007\$)

Year	2007	2009	2012		2017	
Quality Improvement Credit Status			Without Credit	With Credit	Without Credit	With Credit
Total, \$/Dry Ton	\$47.00	\$32.80	\$32.80	\$32.80	\$32.80	\$28.30
Harvest and Collection	\$18.40	\$10.60	\$10.60	\$10.60	\$10.60	\$9.10
Storage and Queuing	\$6.10	\$3.70	\$3.70	\$3.70	\$3.70	\$3.70
Preprocessing	\$7.80	\$6.20	\$6.20	\$6.20	\$6.20	\$3.20
Transportation and Handling	\$14.70	\$12.30	\$12.30	\$12.30	\$12.30	\$12.30
Total, \$/gal Ethanol*	\$0.72	\$0.44	\$0.37	\$0.37	\$0.37	\$0.32
Harvest and Collection	\$0.28	\$0.14	\$0.12	\$0.12	\$0.12	\$0.10
Storage and Queuing	\$0.09	\$0.05	\$0.04	\$0.04	\$0.04	\$0.04
Preprocessing	\$0.12	\$0.08	\$0.07	\$0.07	\$0.07	\$0.04
Transportation and Handling	\$0.23	\$0.17	\$0.14	\$0.14	\$0.14	\$0.14
*Gallons Ethanol/Dry Ton	65.3	74.3	89.8	89.8	89.8	89.8

⁸ The ethanol yields were based on the baseline biochemical conversion process concept for dry corn stover described in more detail in Section 3.2.

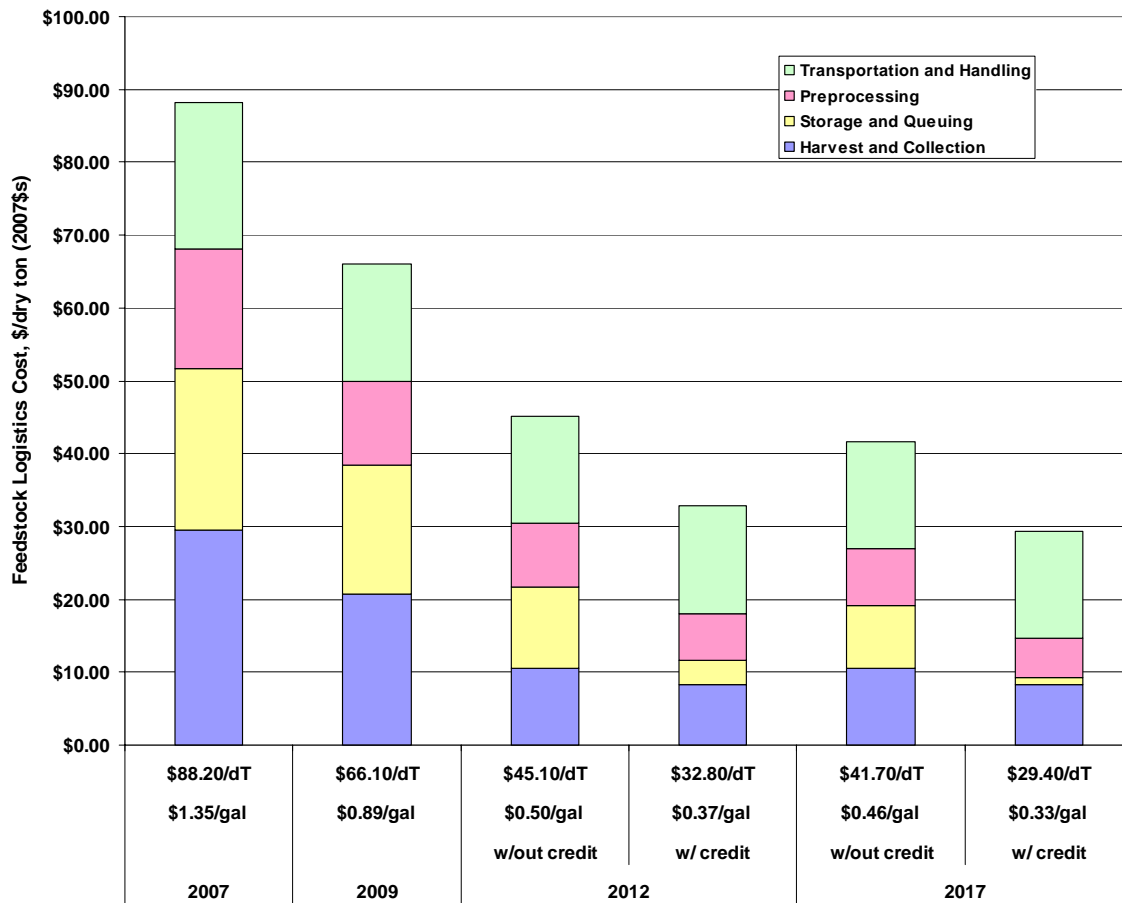

Figure 3-9: Wet Herbaceous Feedstock Logistics Costs

Table 3-4: Wet Herbaceous Feedstock Logistics Costs (2007\$)

Year	2007	2009	2012		2017	
Quality Improvement Credit Status			Without Credit	With Credit	Without Credit	With Credit
Total, \$/Dry Ton	\$88.20	\$66.10	\$45.10	\$32.80	\$41.70	\$29.40
Harvest and Collection	\$29.50	\$20.70	\$10.60	\$8.30	\$10.60	\$8.30
Storage and Queuing	\$22.20	\$17.80	\$11.10	\$3.40	\$8.60	\$0.90
Preprocessing	\$16.40	\$11.50	\$8.70	\$6.40	\$7.80	\$5.50
Transportation and Handling	\$20.10	\$16.10	\$14.70	\$14.70	\$14.70	\$14.70
Total, \$/gal Ethanol*	\$1.35	\$0.89	\$0.50	\$0.37	\$0.46	\$0.33
Harvest and Collection	\$0.45	\$0.28	\$0.12	\$0.09	\$0.12	\$0.09
Storage and Queuing	\$0.34	\$0.24	\$0.12	\$0.04	\$0.10	\$0.01
Preprocessing	\$0.25	\$0.15	\$0.10	\$0.07	\$0.09	\$0.06
Transportation and Handling	\$0.31	\$0.22	\$0.16	\$0.16	\$0.16	\$0.16
*Gallons Ethanol/Dry Ton	65.3	74.3	89.8	89.8	89.8	89.8

The cases with the credits were developed to identify compositional improvements that could be

made as a result of the logistics activities. These figures show that the largest cost reduction opportunities exist in the wet herbaceous feedstocks. Additionally, it is expected that wet herbaceous feedstocks will supply a majority of the future biorefineries. Therefore, while the Program funds research and development in wet and dry herbaceous and woody feedstocks, priority is given to the wet herbaceous feedstock R&D. Current costs and the potential for cost reduction for woody biomass logistics will be estimated in the near future. This information will help identify the highest priorities for woody feedstock logistics R&D.

Detailed information on the technical performance targets that form the basis for the conceptual logistics systems designs and cost estimates are provided in Appendix B, Tables B-2 and B-3 for the dry and wet herbaceous systems respectively. These targets are for the current baseline concept for collection, storage, preprocessing, transportation and delivery to conversion reactor inlet.⁹

3.1.6 FEEDSTOCK PLATFORM MILESTONES AND DECISION POINTS

The key Feedstock platform milestones, inputs/outputs and decision points to complete the tasks described in section 3.1.4 are summarized in the chart in Figure 3-10.

The highest-level milestones serve as the performance goals (listed in section 3.1.2) for the feedstock platform. These performance goals represent the culmination of work that has progressed from bench studies to prototype equipment operation to integrated prototype equipment operation. Figure 3-10a lays out the full set of program-level milestones for dry corn stover logistics to show the progression from bench to integrated prototype operation and the alignment with the feedstock platform tasks as defined by the WBS.

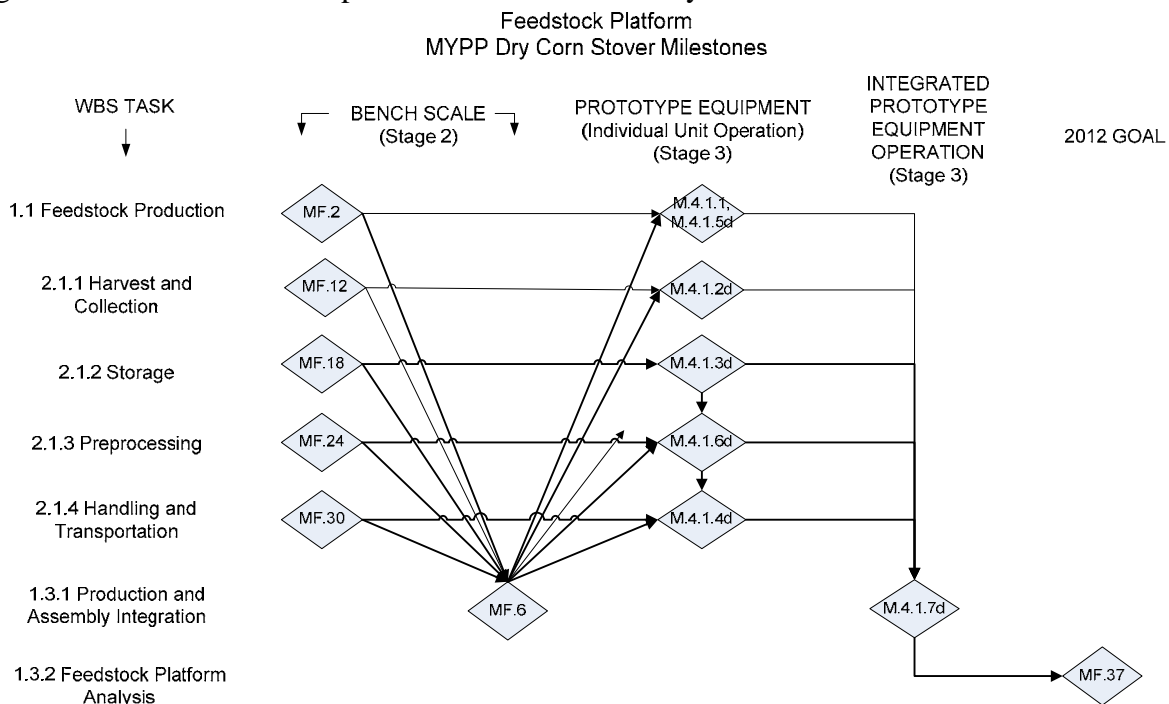

⁹ A report describing the detailed design of the baseline logistics concept is in progress and is scheduled to be completed by the end of FY 2007.

Figure 3-10a. Feedstock Conversion Platform Dry Corn Stover Milestones

The milestones and decision points, represented by diamonds in the diagram, are detailed in Figure 3-10. At each scale, the unit operations must meet the set of feedstock performance metrics defined for the route, as detailed in Appendix B, Tables B-1, B-2 and B-3. The core R&D work on a particular process route is complete when an integrated pilot or prototype system has been successfully demonstrated and validated.

The figure above shows how process development and scale-up for a particular route are planned and tracked as follows:

- Bench Scale
 - Column 1: Successful completion of bench-scale work leads to down-selection of unit operation design and configuration for dry corn stover (in context of integrated process applicability)
- Gate 3 Stage Gate Review
 - Column 2: Formal decision (via Stage 3 Gate Review¹⁰) to move to prototype equipment with defined integrated process configuration for dry corn stover (based on bench scale data)
- Pilot Scale
 - Column 3: Validate individual unit operation performance for dry corn stover in prototype equipment
 - Column 4: By 2009, validate integrated feedstock logistics for dry corn stover in prototype equipment (this is the feedstock performance goal listed in Section 3.1.2)
 - Column 5: Determine modeled dry corn stover logistics cost based on data from integrated prototype equipment operation (this supports the 2012 Joule milestone-JF.2012)

The following definitions apply to the programmatic milestones in Figure 3-10.

- **Downselect:** Based on bench-scale evaluation of viable processes/technologies, select the process design configuration that will move forward for demonstration in an integrated pilot plant or prototype system.
- **Demonstrate:** At pilot scale and beyond, verify that the unit operations operate as designed and meet the complete set of performance metrics (individually and as an integrated system).
- **Validate:** At pilot scale and beyond, ensure the process/system meets desired expectations/original intent. Validation goes beyond just meeting all of the performance metrics; it is an assessment of whether the system actually fulfills/completes a portion of the program effort.

¹⁰ Stage Gate Management in the Biomass Program (Rev. 2. February 2005).
<http://devafdc.nrel.gov/pdfs/9276.pdf>

Figure 3-10: Feedstock Platform Gantt Chart

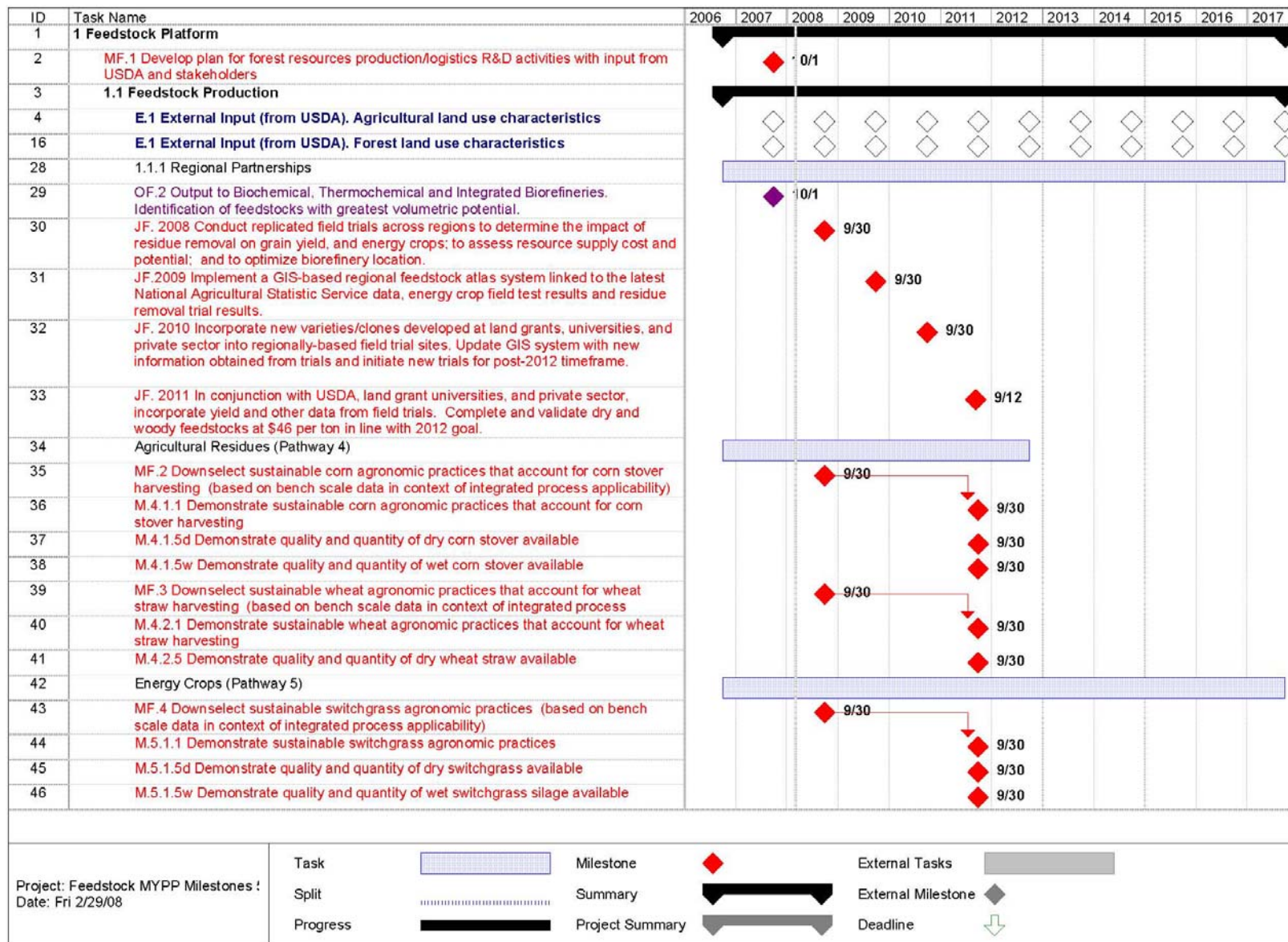

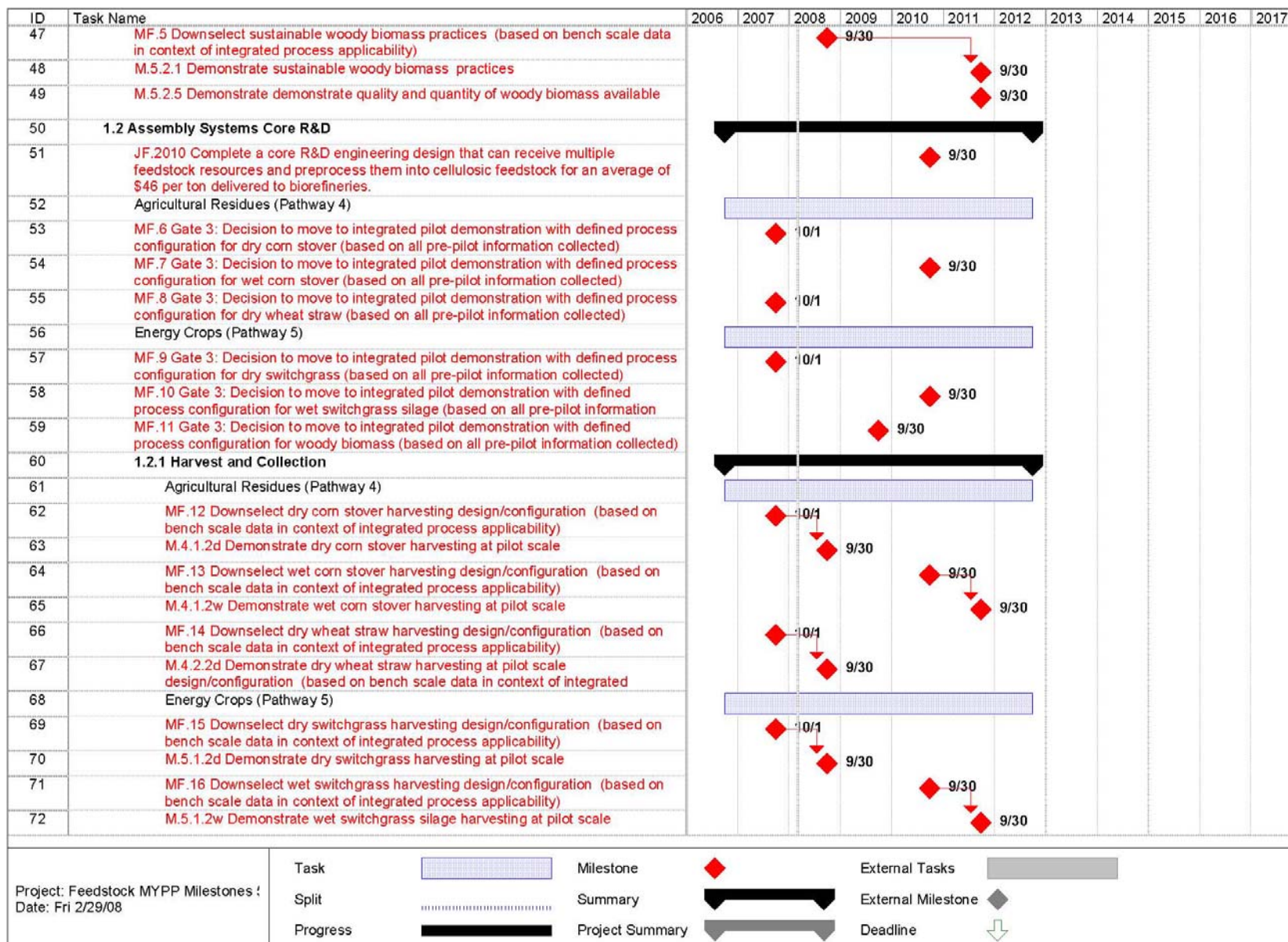

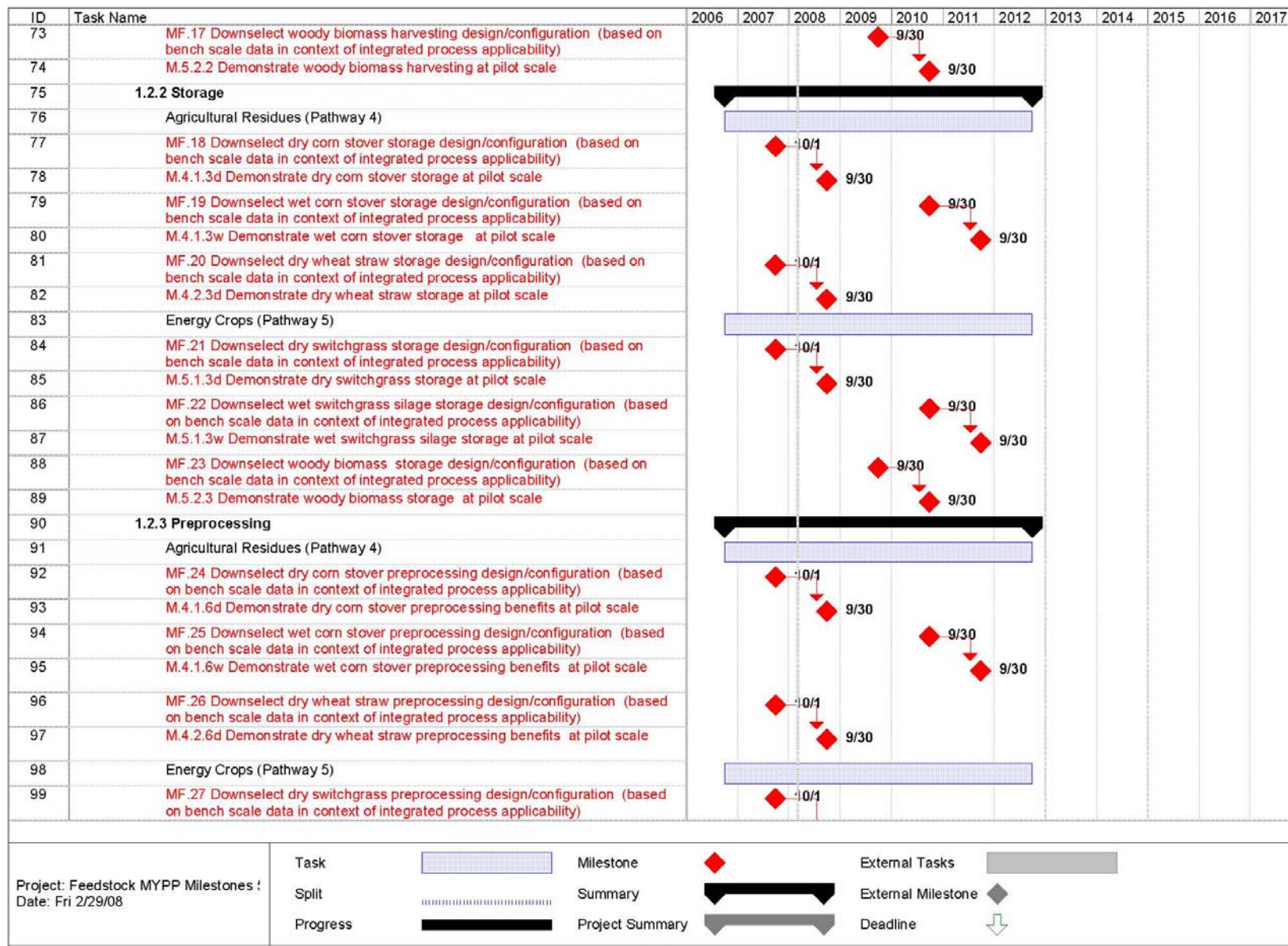

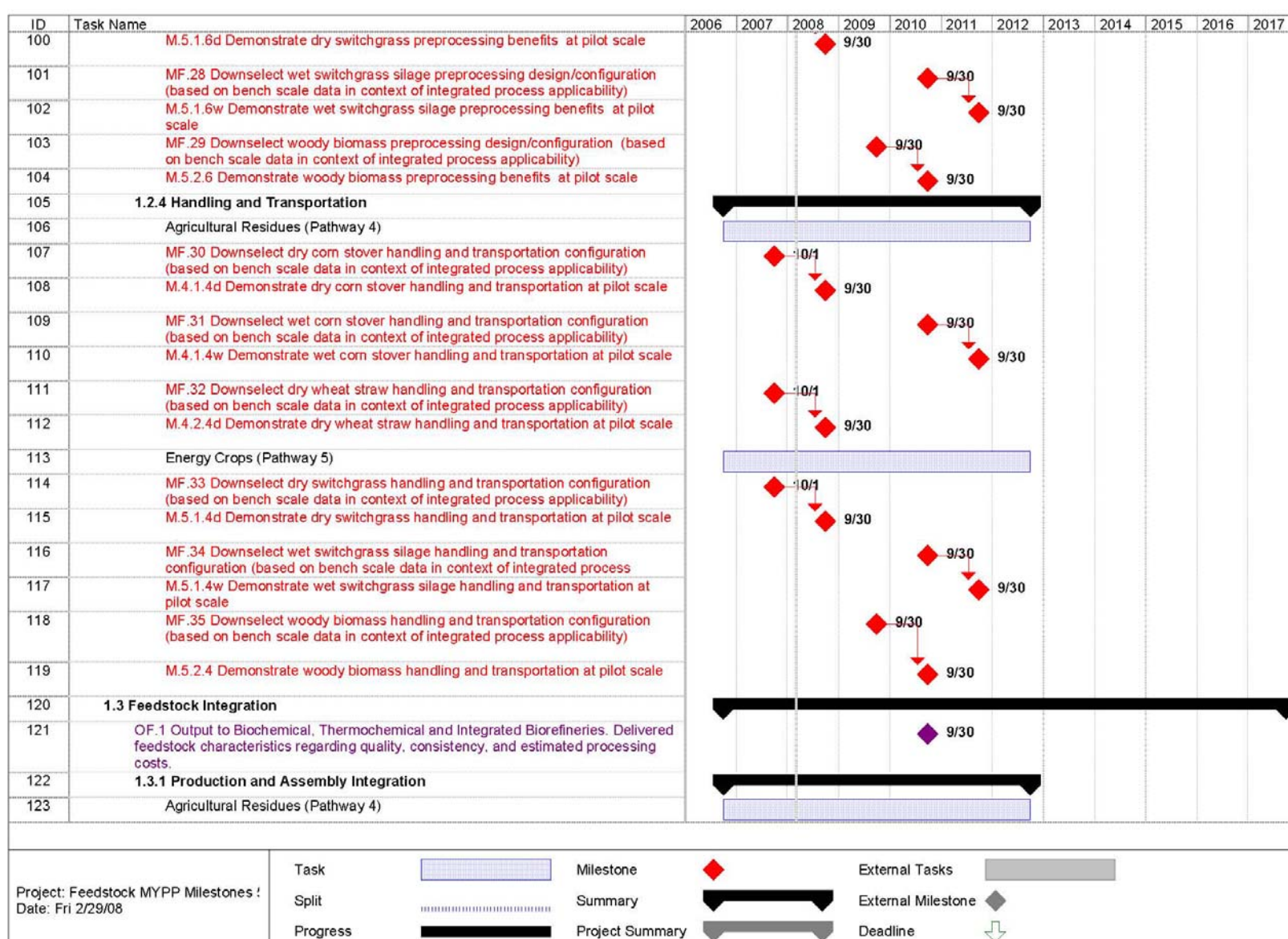

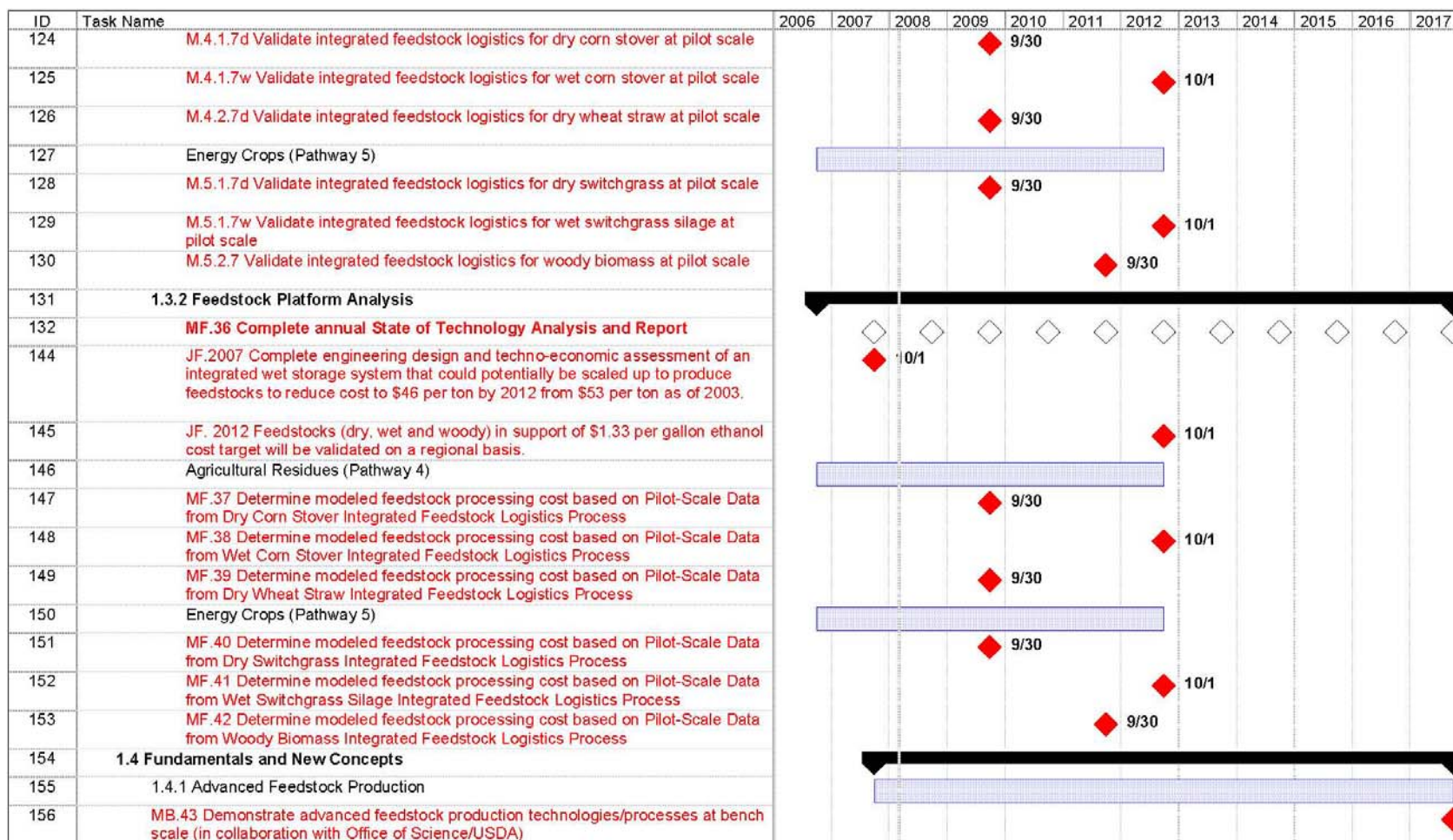

Project: Feedstock MYPP Milestones !
Date: Fri 2/29/08

Task		Milestone		External Tasks	
Split		Summary		External Milestone	
Progress		Project Summary		Deadline	

3.2 CONVERSION PLATFORM

The strategic goal of the conversion element is to *develop technologies for converting feedstocks into cost-competitive liquid transportation fuels, such as ethanol, as well as bioproducts and biopower*. The diversity of the biomass resource leads to the need to develop multiple conversion technologies that can efficiently deal with the broad range of feedstock physical and chemical characteristics. The Program is focusing on two primary conversion routes – biochemical and thermochemical conversion, each being pursued along their respective platforms within the Conversion platform (Figure 3-11). Within both the conversion platforms, there are many possible variations, but the main differences are in the primary catalytic system employed and the intermediate building blocks produced.

While the two platforms are described separately, it is envisioned that the combined use of technologies from both conversion platforms offers the greatest opportunity for optimizing biomass conversion into a variety of different fuels, chemicals and energy products. The early years of the industry may not see such complex biorefineries, but some complexity may be added as technologies evolve with time.

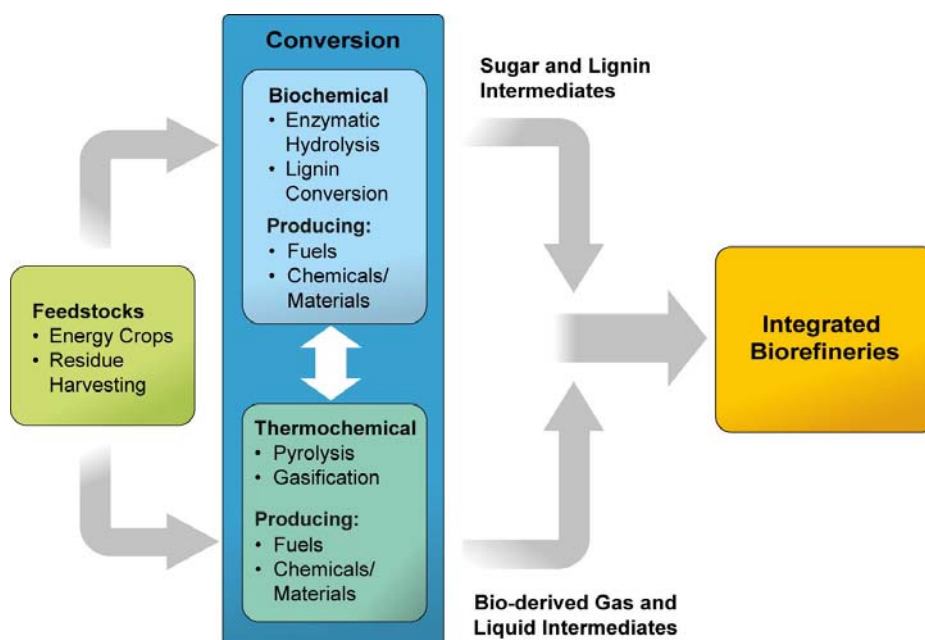

Figure 3-11: Conversion Routes for Biomass to Biofuels

3.2.1 BIOCHEMICAL CONVERSION PLATFORM

The Biochemical platform is focused on reducing the cost of converting lignocellulosic biomass to mixed, dilute sugars and their further conversion to liquid transportation fuels, such as ethanol, to enable successful integrated biorefineries. Biochemical conversion uses biocatalysts, such as enzymes and microorganisms, in addition to heat and chemical catalysts, to convert the carbohydrate portion of the biomass (hemicellulose and cellulose) into an intermediate sugar

stream. The biomass sugars act as intermediate building blocks which are then fermented to ethanol and other products. The remaining lignin portion of the biomass can be used for heat and power, or alternatively used to produce additional fuels and chemicals via thermochemical processing.

Biochemical platform R&D will make further improvements to feedstock interface, pretreatment and conditioning, enzymes and fermentation processes, in addition to process integration in order to reduce sugar costs; these economically viable technologies will act as the springboard to launching the next generation technology to produce ethanol and other products from a wide range of cellulosic feedstocks.

Biochemical Platform Unit Operations

The conceptual block flow diagram in Figure 3-12 outlines the main technologies/unit operations of the baseline biochemical biomass-to-ethanol process. Process details are available in the most recent design report.¹¹

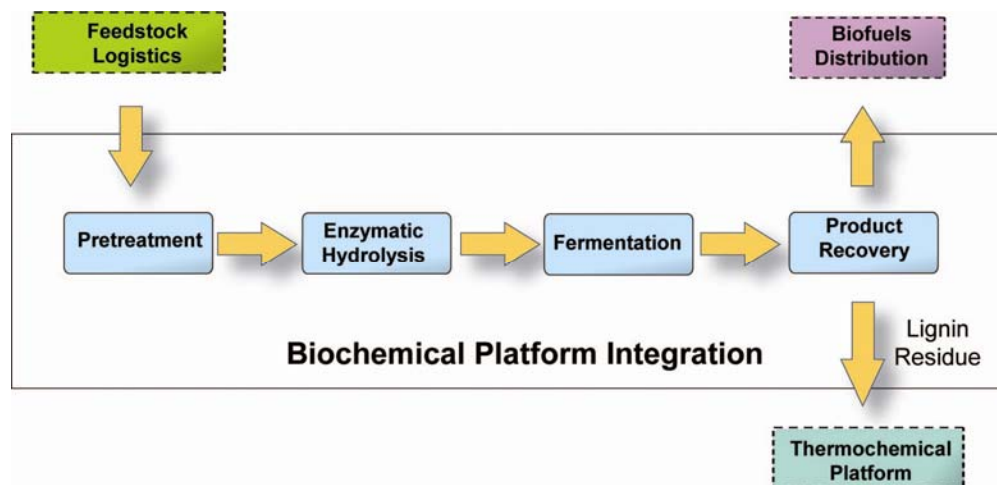

Figure 3-12: Biochemical Conversion Route for Biomass to Biofuels

Pretreatment (Prehydrolysis): In this step, biomass feedstock undergoes a thermochemical process to break down the hemicellulose fraction of the feedstock into a mixture of soluble five-carbon sugars – xylose and arabinose, and soluble six-carbon sugars – mannose, galactose, and glucose. This partial solubilization makes the remaining solid cellulose fraction more accessible for enzyme saccharification later in the process. A small portion of the cellulose is often converted to additional glucose in this step, and a portion of the lignin fraction may also be solubilized. The specific mix of sugars released depends on the feedstock used and pretreatment.

Conditioning (Optional): In some process configurations, the pretreated material goes through a hydrolyzate conditioning process which removes undesirable byproducts from the pretreatment

¹¹ “Lignocellulosic Biomass to Ethanol Process Design and Economics Utilizing Co-Current Dilute Acid Prehydrolysis and Enzymatic Hydrolysis for Corn Stover,” NREL TP-510-32438, June 2002.

process that are toxic to the fermenting organism.

Enzymatic Hydrolysis: In the enzymatic hydrolysis step, the pretreated material, with the remaining solid carbohydrate fraction being primarily cellulose, is saccharified with cellulase enzymes, releasing glucose. Addition of other enzymes, such as xylanases, in this step may allow for less severe pretreatment, resulting in a reduced overall pretreatment and hydrolysis cost. Enzymatic hydrolysis requires several days, after which the mixture of sugars and any unreacted cellulose is transferred to the fermenter. The process concept under development assumes that the cellulase enzymes are purchased from enzyme companies, like other consumable catalysts and chemicals. The current concept may also combine the enzymatic hydrolysis and fermentation steps.

Fermentation: In the fermentation step, an inoculum of a fermenting organism is added and fermentation of all sugars to ethanol is carried out while continuing to utilize the enzymes for further glucose production from any remaining solid cellulose. After a few days of fermentation and continued saccharification, nearly all of the sugars are converted to ethanol. The resulting beer (low-concentration ethanol) is sent to product recovery.

Product Recovery: Product recovery involves distilling the beer to separate the ethanol from the water and residual solids. A final dehydration step removes any remaining water from the ethanol. Residual solids are composed primarily of lignin which can be burned for combined heat and power generation or thermochemically converted to synthesis gas or pyrolysis oil intermediates for other uses. This process is part of the Thermochemical platform focus.

Biochemical Platform Interfaces

Feedstock Logistics Interface: The Feedstock platform provides preprocessed feedstock that meets the requirements (composition, quality, size, etc.) as defined by the specific biochemical conversion process configuration. Close coordination between the Feedstock and Biochemical Conversion platforms is required to ensure that the feedstock and the process are optimized together for the lowest overall cost and highest conversion efficiency of the biomass.

Thermochemical Platform Interface: Lignin and other byproducts/residues of the biochemical conversion process can be used to produce the electricity required for the production process. Lignin can also be thermochemically converted to fuels and chemicals.

Biofuels Distribution Interface: The next step in the biomass-to-biofuels supply chain is the biofuels distribution step. Biofuels leaving a biorefinery must meet all applicable federal, state and local codes and standards.

3.2.1.1 BIOCHEMICAL PLATFORM SUPPORT OF PROGRAM STRATEGIC GOALS

The Biochemical platform's strategic goal is to *develop technologies for converting feedstocks into cost-competitive liquid transportation fuels, such as ethanol, as well as bioproducts and biopower.*

The Biochemical platform directly addresses and supports production of fuels in the Agricultural

Residues Processing and the Energy Crops Processing pathways. It also indirectly supports the production of bioproducts from both these pathways and any pathway conversion where biochemical processing can be considered as an option.

3.2.1.2 BIOCHEMICAL PLATFORM SUPPORT OF PROGRAM PERFORMANCE GOALS

The overall performance goal of the Biochemical platform is to reduce the estimated mature technology processing cost¹² for converting cellulosic feedstocks to ethanol to \$0.82 per gallon in 2012 (see Figure 3-14 for additional information) and \$0.60 per gallon in 2017 (2007\$) based on data at the integrated pilot scale. The baseline processing cost for dry corn stover to ethanol was \$1.59 per gallon (2007\$) in FY 2005 based on data at the bench scale.

The performance goals for the pathways under investigation are as follows:

Agricultural Residues Pathway

- By 2012, validate integrated production of ethanol from corn stover, via biochemical conversion route, at pilot scale

Energy Crops Pathway

- By 2017, validate integrated production of ethanol from switchgrass, via biochemical conversion route, at pilot scale.

3.2.1.3 BIOCHEMICAL PLATFORM TECHNICAL CHALLENGES AND BARRIERS

Bt-A. Biomass Fractionation: Fractionation can be used to increase the value of the individual components in biomass prior to their subsequent conversion to products. Currently, the interactions between chemical, biological, solvation (ability to go into solution), and mechanical processes to ultimately allow biomass to be more efficiently fractionated at high yield into high-purity components is insufficiently understood to implement commercially.

Bt-B. Biomass Variability: The characteristics of biomass can vary widely in terms of physical and chemical composition, size, shape, moisture content, and bulk density. These variations can make it difficult (or costly) to supply biorefineries with feedstocks of consistent, acceptable quality year-round, and also feedstock variability affects overall conversion rate and product yield of biomass conversion processes.

Bt-C. Biomass Recalcitrance: Lignocellulosic biomass feedstocks are naturally resistant to chemical and/or biological degradation. The fundamental role of biomass structure and composition and the critical physical and chemical properties that determine the susceptibility of cellulosic substrates to hydrolysis are not well understood. This lack of understanding of the root causes of the recalcitrance of biomass limits the ability to focus efforts to improve the cost-effectiveness and efficiency of pretreatment and other fractionation processes.

Bt-D. Pretreatment Chemistry: Thermochemical prehydrolysis of biomass, typically referred

¹² Estimated mature technology processing cost means that the capital and operating costs are assumed to be for an “nth plant” where several plants have been built and are operating successfully so that additional costs for risk financing, longer startups, under performance, and other costs associated with pioneer plants are not included.

to as pretreatment, is required to break down the structure of biomass and increase its susceptibility to subsequent enzymatic hydrolysis by cellulase enzymes. The critical physical and chemical properties that determine the susceptibility of cellulosic substrates to hydrolysis and the role that lignin and other pretreatment products play in impeding access to cellulose are not well enough understood. Continued significant cost reductions in pretreatment technologies via improved sugar yields and quality require developing a better understanding of pretreatment process chemistries, including the kinetics of hemicellulose and cellulose hydrolysis.

Bt-E. Pretreatment Costs: Pretreatment reactors typically require expensive materials of construction to resist acid or alkali attack at elevated temperatures. In addition, the impact of reaction configuration and reactor design on thermochemical cellulose prehydrolysis is not well understood. Developing lower-cost pretreatments depends on the ability to process the biomass in reactors designed for maximum solid levels and fabricated out of cost-effective materials.

Bt-F. Cellulase Enzyme Production Cost: Cellulase enzymes remain a significant portion of the projected production cost of sugars from cellulosic biomass. Cost-effective enzyme production technologies are not currently available, although significant progress has been made through concerted efforts with industrial enzyme producers.

Bt-G. Cellulase Enzyme Loading: Reducing the cost of enzymatic hydrolysis depends on identifying more efficient enzyme preparations and enzyme hydrolysis regimes that permit more cost-effective and lower ratios of enzyme to substrate to be used.

Bt-H. Enzyme Biochemistry: Currently available enzymes do not exhibit the high thermostability and substantial resistance to sugar end-product inhibition. Developing enzymes that enable low-cost enzymatic hydrolysis technology requires more understanding of the fundamental mechanisms underlying the biochemistry of enzymatic cellulose hydrolysis, including the impact of biomass structure on enzymatic cellulose decrystallization. Additional efforts aimed at understanding the role of cellulases and their interaction not only with cellulose but also the process environment is needed to affect further reductions in cellulase cost.

Bt-I. Cleanup/Separation: Sugar solutions resulting from thermochemical pretreatment are impure, containing a mixture of sugars and a variety of non-sugar components. Potential impurities include acetic acid liberated upon hydrolysis of hemicellulose, lignin-derived phenolics solubilized during pretreatment, inorganic acids or alkalis or other compounds introduced during pretreatment, various salts, and hexose and pentose sugar degradation or transglycosylation products. The presence of some of the non-sugar components can be inhibitory to microbial fermentation or biocatalysis or can poison chemical catalysts. Low-cost purification technologies need to be developed that can remove impurities from hydrolysates and provide concentrated, clean sugar feedstocks to manufacture biofuels and biobased products.

Bt-J. Fuels Organism Development: Fermentation organisms used today have not been optimized for production of liquid fuels (ethanol, butanol and other alcohols) from the sugar mixture in the hydrolyzate broth produced during biomass pretreatment and enzymatic hydrolysis. For example, current organisms are not capable of utilizing the five-carbon sugar components, xylose and arabinose, in the biomass hydrolyzate as efficiently as glucose. In addition, impurities generated during pretreatment inhibit the organism, resulting in slow fermentations and incomplete utilization of sugars; this can lead to the need for costly purification. Improvements in fermentative organisms to perform in hydrolysate broths can significantly lower capital costs.

Bt-K. Biological Process Integration: Process integration remains a key technical barrier hindering development and deployment of biochemical conversion technologies. Biochemical conversion technologies currently present large scale-up risks because of lack of high-quality performance data on integrated processes carried out at the high solids conditions required for industrial operations. The effect of feed and process variations throughout the process must be understood to ensure robust, efficient biorefineries. Process integration work is essential for characterizing the complex interactions that exist between many of the processing steps, identifying unrecognized separation requirements, addressing bottlenecks and knowledge gaps, and generating the integrated performance data necessary to develop predictive mathematical models that can guide process optimization and scale-up.

Bt-L. Biochemical/Thermochemical Processing Integration: Integration of the entire biorefinery is the final conversion barrier and overcoming it will require successful integration at the interfaces between the biochemical and thermochemical processes. For example, the lignin residue can be used as a feedstock for syngas or bio-oil production and for subsequent conversion to combined heat and power, fuels, or chemicals. Without planned and managed integration, the complete picture of biomass conversion to fuels and chemicals will not be clear enough to attract potential developers because the risks of commercialization will be too high for financiers. As conversion technologies mature, higher levels of integration will be feasible and second generation biorefineries are envisioned to be closely coupled biochemical / thermochemical facilities enabling the most efficient use of a wide range of feedstocks.

3.2.1.4 BIOCHEMICAL PLATFORM APPROACH FOR OVERCOMING CHALLENGES AND BARRIERS

The approach for overcoming biomass conversion technical challenges and barriers is outlined in the Biochemical platform's work breakdown structure (WBS), as shown in Figure 3-13. The platform has four key activities which are further broken down into tasks. One of the major organizational goals within the platform is to better coordinate and align tasks to make sure all R&D efforts are directed toward achieving the same programmatic goal.

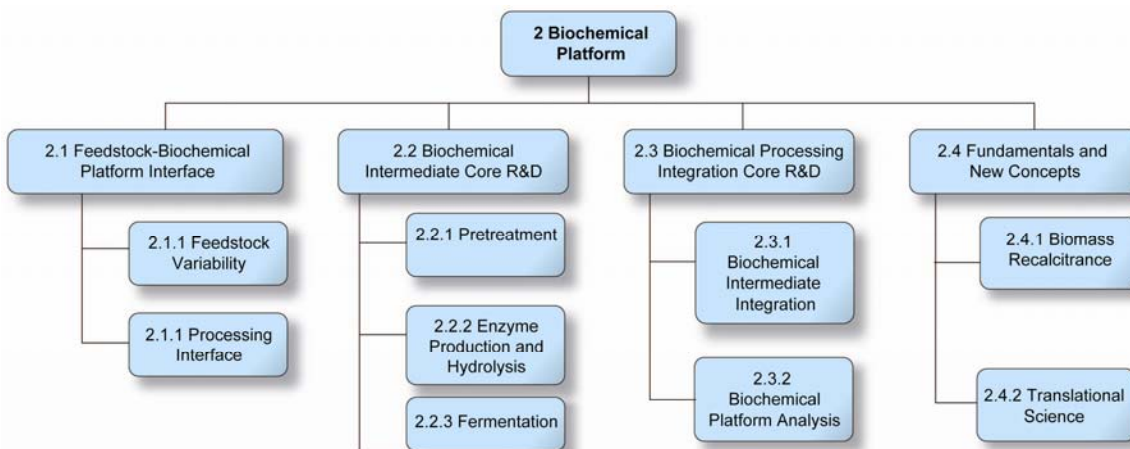

Figure 3-13: Work Breakdown Structure for Biochemical Platform Core R&D

The current platform efforts are focused on overcoming the recalcitrance of biomass (when compared to starch, cellulose is not easily broken down into sugars); validating advanced conversion enhancements such as increased solids loadings, improved separations and milder conditions; more robust fermentation organisms; and integrating conversion technologies both within the Biochemical platform with upstream feedstock collection/transport processes and downstream thermochemical conversion processes. Core research, which addresses the key technical barriers, is performed by national laboratories, industry and universities. Relevance to industrial and commercial applications to foster transfer of technology will be ensured via stage gate reviews by industry, partnering with industry as appropriate, and patenting and publishing the results.

The R&D approach of each WBS task element is described below, while Table 3-5 summarizes each task element's work as it relates to specific platform barriers and biorefinery pathways.

WBS 2.1 Feedstock-Biochemical Interface R&D

Establishing the value of and requirements for feedstock assembly processes to feed bioconversion processes are necessary for the development of biorefineries. Linking feedstock collection/transport processes with conversion processes allows evaluation of technology options and trade-offs on both sides of the processing interface. Activities will develop cost and quality specifications for feedstock assembly technologies that are compatible with biochemical conversion technologies. *The key technical target is to maintain or even improve feedstock yield potential through targeted logistics operations between the field or forest and the biorefinery.*

WBS 2.2 Biochemical Intermediate Core R&D

Overcoming the barriers associated with high capital and operating cost and sub-optimal sugar yields is key to developing an integrated pretreatment, enzymatic hydrolysis and fermentation process. The investigation and evaluation of pretreatment approaches are aimed at reducing the cost of pretreatment and increasing the enzymatic digestibility of residual cellulose and hemicellulose in pretreated biomass. Fundamental research is focused on improving existing fermentation organisms, expanding the knowledge of new organisms and developing advanced technologies to overcome the key rate limiting steps in the conversion of biomass to fermentable sugars. *The key technical targets involve achieving high sugar and ethanol conversion cost, rates and yields in the core processing steps of pretreatment, enzymatic hydrolysis and fermentation.*

WBS 2.3 Biochemical Processing Integration Core R&D

Investigating pretreatment and enzymatic hydrolysis technologies together with downstream synthesis identifies the issues and opportunities of integration. Integration of biomass pretreatment, saccharification and fermentation steps can improve overall efficiency and reduce cost. In addition, the effect of feed and process variations throughout the process must be understood to ensure robust, efficient biorefineries that produce fuels and products. *The key technical target is to maintain high conversion rates from the individual operations in an integrated process configuration, ideally at high solids loadings.*

WBS 2.4 Fundamentals and New Concepts

A fundamental understanding of the factors and causes underlying the recalcitrance of biomass to biological and chemical degradation is needed to make processing more specific and less

costly. The development of tools such as molecular modeling and cell wall microscopy is enabling a more complete understanding of biomass structure and the most appropriate methods to convert it. With this knowledge, advanced energy crops can be developed that require minimal processing. R&D efforts outlined in the Office of Science and EERE's recently developed joint roadmap¹³ will directly feed this R&D area, providing basic science groundwork to develop applied and ultimately integrated process solutions for biomass conversion. *The key technical target is developing basic knowledge of biomass and biological systems that can ultimately be used to develop new or improved technologies that increase conversion efficiency and/or reduce conversion cost.* As feedstock prices increase with supply and demand, decreased conversion costs will allow the industry to utilize a wider range of feedstocks at varying costs.

¹³ "Breaking the Biological Barriers to Cellulosic Ethanol: A Joint Research Agenda," DOE/SC-0095, June 2006.

Table 3-5: Biochemical Platform Core R&D Task Summary

<i>Platform Goal: Develop technologies for converting feedstocks into cost-competitive commodity liquid fuels, like ethanol, as well as bioproducts and biopower</i>			
WBS Element	Description	Barriers Addressed¹⁴	Pathway(s) Addressed
2.1 Feedstock-Biochemical Platform Interface			
2.1.1 Feedstock Variability	Understanding feedstock variability and options for mitigating impacts on downstream processing 2007-2012 <ul style="list-style-type: none"> Characterize/optimize lignocellulosic biomass feedstocks Assess/mitigate impacts of biomass characteristics on downstream unit operations Determine process sensitivity to differences in feedstock type and quality Identify required process modifications to accommodate feedstock differences 2013-2017 <ul style="list-style-type: none"> Design and manipulate plant cell wall composition and structure to maximize yield of fermentable sugars 	Bt-B: Biomass Variability	<ul style="list-style-type: none"> Agricultural Residue Processing Energy Crops Processing
2.1.2 Processing Interface	Defining and coordinating the interface between feedstock logistics and biochemical conversion processes 2007-2012 <ul style="list-style-type: none"> Evaluate technology options and trade-offs with respect to feedstock assembly and preprocessing with biochemical conversion processes Validate feedstocks as received from feedstock logistics systems at pilot scale 2013-2017 <ul style="list-style-type: none"> Continue efforts with new or emerging feedstocks 	Ft-M: [Feedstock] Overall Integration	<ul style="list-style-type: none"> Agricultural Residue Processing Energy Crops Processing
2.2 Biochemical Intermediate Core R&D			
2.2.1 Pretreatment	Identifying cost-effective, feedstock-specific pretreatment options with respect to chemistry and reactor design 2007-2012 <ul style="list-style-type: none"> Evaluate and compare lignocellulosic biomass pretreatment options (chemistry, reactor design and pretreatment process) with respect to hemicellulose conversion, cellulose digestibility and ethanol production. Select and further develop most promising pretreatment options Validate targeted performance in pilot- scale pretreatment reactor systems 2013-2017 <ul style="list-style-type: none"> Map structures and chemistries of native and prehydrolyzed plant cell walls to better understand cell wall deconstruction 	Bt-D: Pretreatment Chemistry Bt-E: Pretreatment Costs	<ul style="list-style-type: none"> Agricultural Residue Processing Energy Crops Processing
2.2.2 Enzyme Production and Hydrolysis	Increasing fundamental understanding of mechanics of enzymatic hydrolysis to improve efficiency and performance of enzymes and developing optimized enzymatic hydrolysis processes 2007-2012 <ul style="list-style-type: none"> Reduce cost of enzymes by developing high-activity enzyme mixtures and low-cost production processes 	Bt-F: Cellulase Enzyme Production Cost Bt-G: Cellulase enzyme Loading Bt-H: Enzyme	<ul style="list-style-type: none"> Agricultural Residue Processing Energy Crops Processing

¹⁴ see section 3.2.1.3 for description

	<ul style="list-style-type: none"> Define optimum enzymatic hydrolysis conditions/reactor design (for specific feedstocks and process conditions) to reduce enzyme utilization requirements Quantify effects of enzyme loading, strain inoculation time and inoculum charge on integrated hydrolysis/fermentation process performance Validate targeted enzymatic hydrolysis performance of pretreated biomass in scalable system configuration <p>2013-2017</p> <ul style="list-style-type: none"> Develop improved (engineered) enzymes for advanced biochemical conversion technologies 	Biochemistry Bt-I: Cleanup/Separation	
2.2.3 Fermentation	<p>Developing robust ethanol fermentation organisms capable of converting all biomass sugars to ethanol at high yields and rates</p> <p>2007-2012</p> <ul style="list-style-type: none"> Develop multi-sugar fermenting organisms that can tolerate impurities in biomass hydrolysate Validate targeted organism performance on pretreated hydrolysate in scalable system configuration <p>2013-2017</p> <ul style="list-style-type: none"> Develop organism for single-step processing that compares with commercial fermentative organisms and enzymes (at lab scale) 	Bt-J: Fuels Organism Development	<ul style="list-style-type: none"> Agricultural Residue Processing Energy Crops Processing
2.3 Biochemical Processing Integration Core R&D			
2.3.1 Biochemical Intermediate Integration	<p>Defining/coordinating/consolidating the interfaces within biochemical conversion platform</p> <p>2007-2012</p> <ul style="list-style-type: none"> Integrate pretreatment and enzymatic hydrolysis with biomass sugar fermentation to maximize cellulose hydrolysis and sugar fermentation cost, rates and yields Validate targeted integrated process performance in pilot-plant-scale system. <p>2013-2017</p> <ul style="list-style-type: none"> Identify optimized pretreatment technology for use with single-step biological processing 	Bt-K: Biological Process Integration	<ul style="list-style-type: none"> Agricultural Residue Processing Energy Crops Processing
2.3.2 Biochemical Platform Analysis	<p>Developing and employing conceptual models to demonstrate the feasibility of various process design concepts and identify integration issues</p> <p>2007-2012</p> <ul style="list-style-type: none"> Prepare annual State of Technology estimates to show progress to the 2012 performance target Develop conceptual process design and mature technology cost estimates for other feedstocks, including wet corn stover and switchgrass, based on the dry corn stover baseline model Validate 2012 performance target using pilot plant data and baseline process design and mature technology cost estimate <p>2013-2017</p> <ul style="list-style-type: none"> Complete conceptual design reports on advanced conversion technology configurations including significant process consolidation (e.g. single step biological processing) 	Bt-K: Biological Process Integration Bt-L: Biochemical/Thermochemical Processing Integration	<ul style="list-style-type: none"> Agricultural Residue Processing Energy Crops Processing Forest Resources Processing
2.4 Fundamentals and New Concepts			
2.4.1 Biomass Recalcitrance	<p>Determining the factors that contribute to biomass recalcitrance and how best to deconstruct plant cell walls</p> <p>2007-2012</p>	Bt-A: Biomass Fractionation Bt-C: Biomass	<ul style="list-style-type: none"> Agricultural Residue Processing

	<ul style="list-style-type: none"> Define the relationships between pretreatment conditions and biomass structural changes to selectively remove sugars Determine how cellulase enzymes move along cellulose chains Define how cellulases and other enzymes interact with plant structure Investigate the basic mechanisms that will provide the framework for next generation deconstruction technologies <p>2013-2017</p> <ul style="list-style-type: none"> Continue to investigate the basic mechanisms of deconstructing plant cell walls in the broad diversity of bioenergy feedstocks 	<p>Recalcitrance Bt-D: Pretreatment Chemistry Bt-G: Cellulase enzyme Loading Bt-H: Enzyme Biochemistry</p>	<ul style="list-style-type: none"> Energy Crops Processing Forest Resources Processing
2.4.2 Translational Science	<p>Developing and applying systems biology methods for enhanced understanding of the basic mechanisms in biomass conversion</p> <p>2007-2017</p> <ul style="list-style-type: none"> Develop systems biology methods for strain improvement of enzyme producing and fermentative microorganisms <p>2013-2017</p> <ul style="list-style-type: none"> Apply systems biology methods to identify and improve enzyme producing and fermentative microorganisms for use with a wide range of feedstocks 	<p>Bt-J: Fuels Organism Development</p>	<ul style="list-style-type: none"> Agricultural Residue Processing Energy Crops Processing Forest Resources Processing
<p>Beyond 2017: Progress in understanding the scientific basis for biomass conversion, and figuring out how to exploit that knowledge will play key roles in the evolution of the Biochemical Conversion platform. Beyond 2017, the identification of new conversion options is expected to lead to a series of improved generations of technology that will be developed, demonstrated and ultimately deployed. Process consolidation is a common theme envisioned in the future of biochemical conversion where advanced technology will combine several unit operations and improve the pretreatment operation. Enzyme production and fermentation will be combined in a single organism, combining three processes (enzyme production, saccharification and fermentation) into one.</p>			

3.2.1.5 PRIORITIZING BIOCHEMICAL PLATFORM BARRIERS

Biochemical platform has prioritized its R&D efforts in overcoming the identified technical barriers based on the analysis results illustrated in Figure 3-14.¹⁵ The figure shows that the largest potential reduction in the cost of sugars can be obtained with bioconversion technology development in enzymes and fermentation areas. Research and development activities are therefore focused to impact this cost.

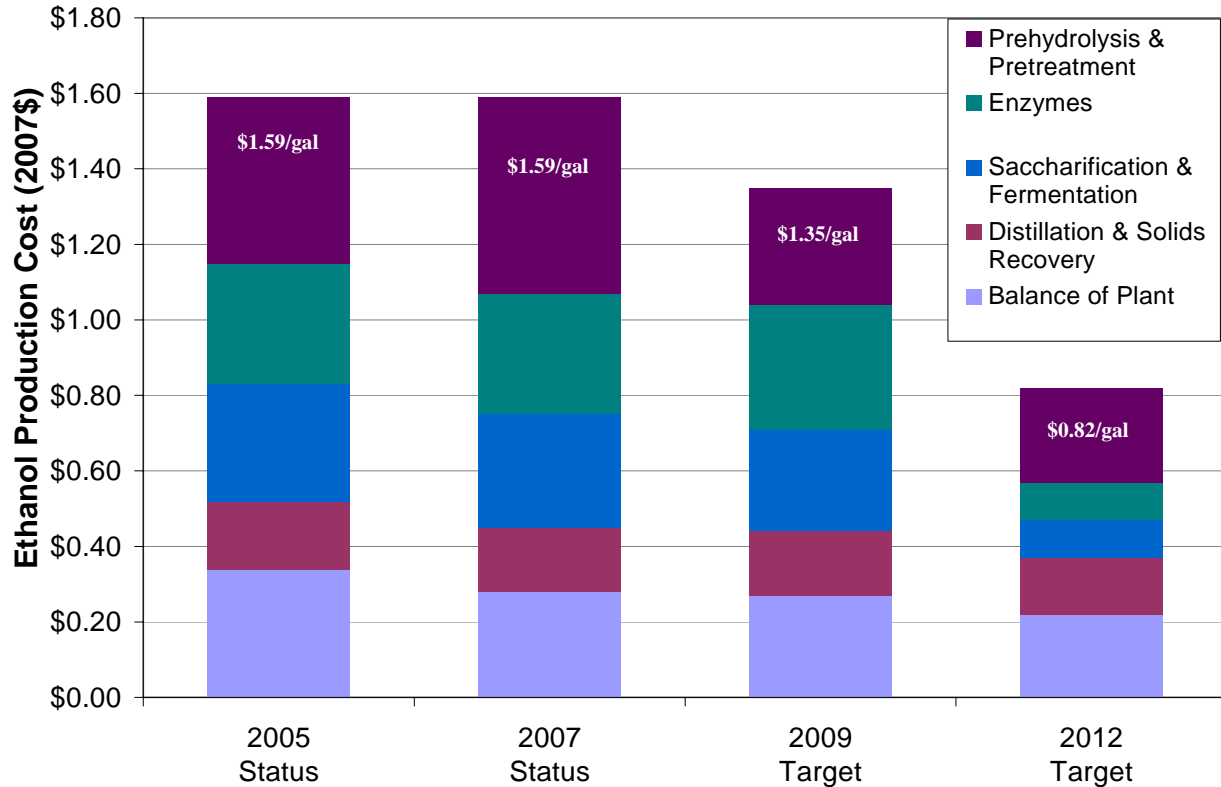

	2005 Status	2007 Status	2009 Target	2012 Target
Processing Total	\$1.59	\$1.59	\$1.35	\$0.82
Prehydrolysis & Pretreatment	\$0.44	\$0.28	\$0.31	\$0.25
Enzymes	\$0.32	\$0.17	\$0.33	\$0.10
Saccharification & Fermentation	\$0.31	\$0.30	\$0.27	\$0.10
Distillation & Solids Recovery	\$0.18	\$0.32	\$0.17	\$0.15
Balance of Plant	\$0.34	\$0.52	\$0.27	\$0.22

Figure 3-14: Biochemical Conversion of Corn Stover to Ethanol (\$/gal in 2007\$s)

(Unit operation cost contribution estimates are based on process concept targets)

Detailed information on the technical performance targets that form the basis for the conceptual biochemical conversion systems designs and cost estimates in Figure 3-14 are provided in

¹⁵ Corn Stover to Ethanol State of Technology and 2012 Targets, NREL Technical Memorandum, March 2007.

Appendix B, Table B-4.¹⁶ The status and targets are based on conversion of dry corn stover via dilute acid pretreatment, enzymatic hydrolysis, ethanol fermentation and recovery, with lignin combustion for combined heat and power production. The State of Technology is a modeled production cost at 2,000 dry tons feedstock/day using data from NREL’s bench-scale biochemical conversion R&D.

3.2.1.6 Biochemical Platform Milestones and Decision Points

The key Biochemical platform milestones, inputs/outputs and decision points to complete the tasks described in section 3.2.1.4 are summarized in the chart in Figure 3-16.

The highest-level milestones serve as the performance goals (listed in section 3.2.1.2) for the biochemical conversion platform. These performance goals represent the culmination of work that has progressed from bench to individual pilot-scale operation to integrated pilot operation. Figure 3-15a lays out the full set of program-level milestones for the biochemical conversion of corn stover to ethanol, showing the progression from bench to integrated pilot operation and the alignment with the biochemical conversion platform tasks as defined by the WBS.

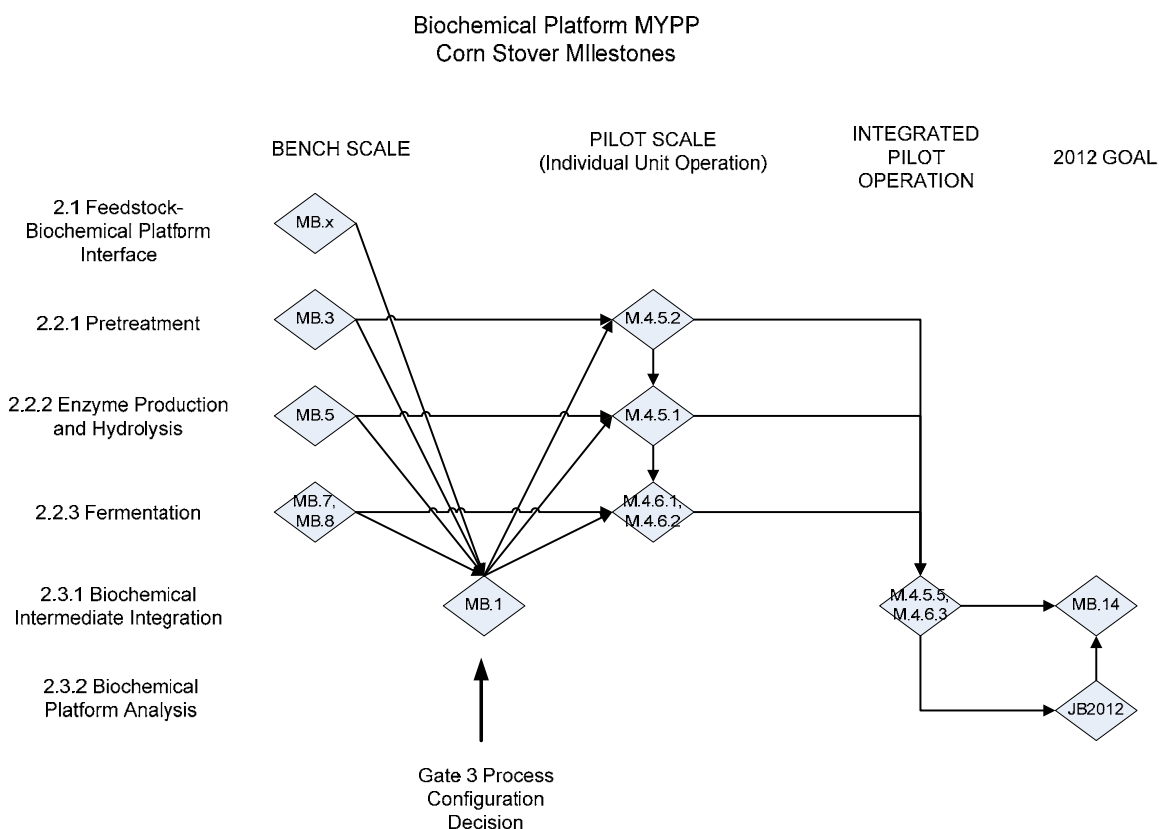

Figure 3-15a. Biochemical Conversion Platform Corn Stover Milestones

16 “Lignocellulosic Biomass to Ethanol Process Design and Economics Utilizing Co-Current Dilute Acid Prehydrolysis and Enzymatic Hydrolysis for Corn Stover,” NREL/TP-510-32438, 2002.

The milestones and decision points, represented by diamonds in the diagram, are detailed in Figure 3-15. At each scale, the unit operations must meet the set of biochemical performance metrics defined for the route, as detailed in Appendix B, Table B-4. The core R&D work on a particular process route is complete when an integrated pilot or prototype system has been successfully demonstrated and validated.

The figure shows how process development and scale-up for a particular route are planned and tracked as follows:

- Bench Scale
 - Column 1: Successful completion of bench scale work leads to down-selection of unit operation design and configuration for corn stover (in context of integrated process applicability)
- Gate 3 Stage Gate Review
 - Column 2: Formal decision (via Stage 3 Gate Review¹⁷) to move to pilot scale operation with defined integrated process configuration for corn stover (based on bench scale data)
- Pilot Scale
 - Column 3: Validate individual unit operation performance for corn stover at pilot scale
 - Column 4: By 2012, validate integrated production of ethanol from corn stover, via biochemical conversion route, at pilot scale (this is one of the biochemical conversion performance goals listed in Section 3.2.1.2)
 - Column 5: Determine modeled ethanol cost based on data from integrated pilot operation (this supports the 2012 Joule milestone-JB.2012)

The following definitions apply to the programmatic milestones in Figure 3-16.

- **Downselect:** Based on bench scale evaluation of viable processes/technologies, select the process design configuration that will move forward for demonstration in an integrated pilot plant or prototype system.
- **Demonstrate:** At pilot scale and beyond, verify that the unit operations operate as designed and meet the complete set of performance metrics (individually and as an integrated system).
- **Validate:** At pilot scale and beyond, ensure the process/system meets desired expectations/original intent. Validation goes beyond just meeting all of the performance metrics; it is an assessment of whether the system actually fulfills/completes a portion of the program effort.

¹⁷ Stage Gate Management in the Biomass Program (Rev. 2. February 2005).
<http://devafdc.nrel.gov/pdfs/9276.pdf>

Figure 3-15: Biochemical Core R&D Gantt Chart

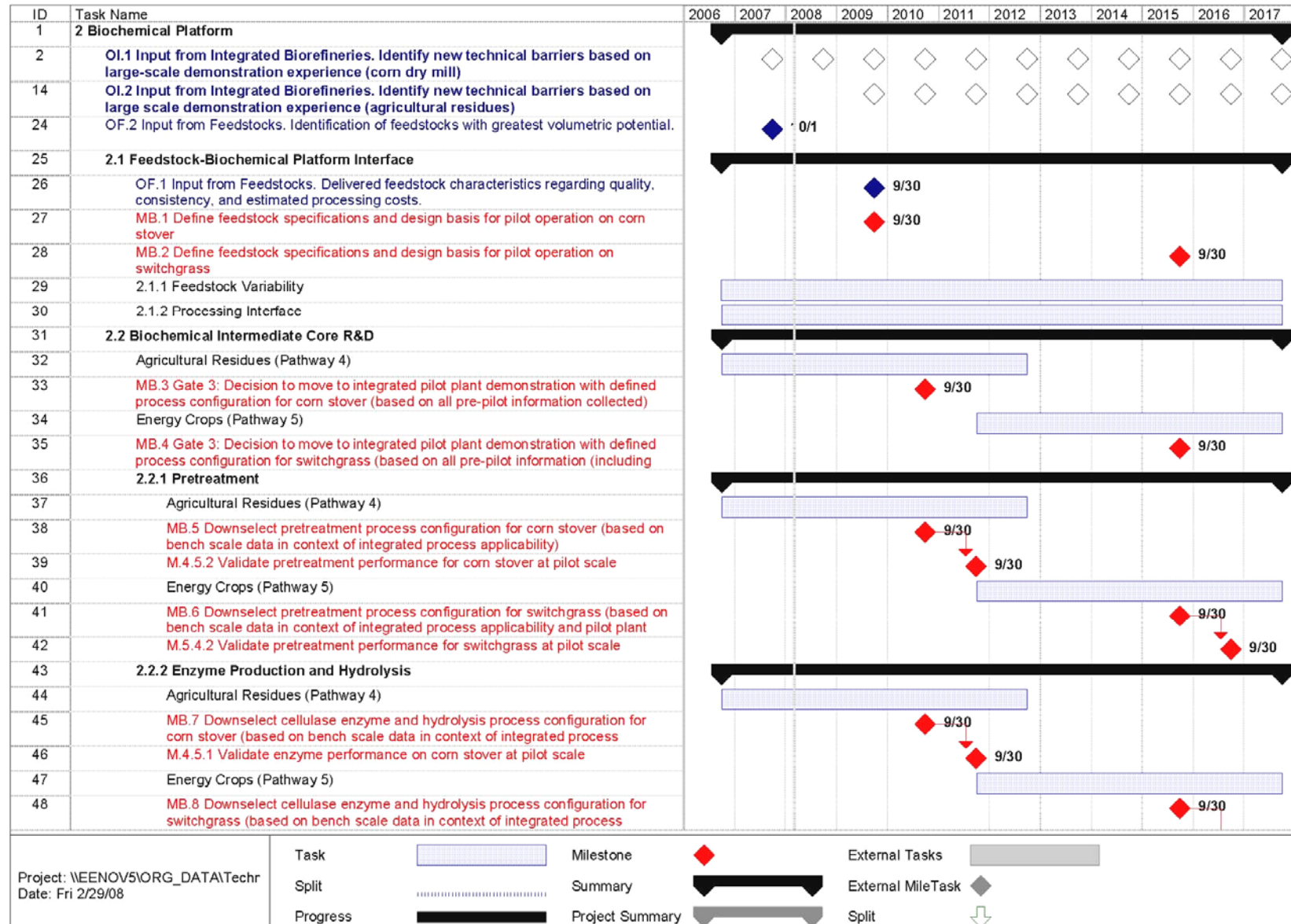

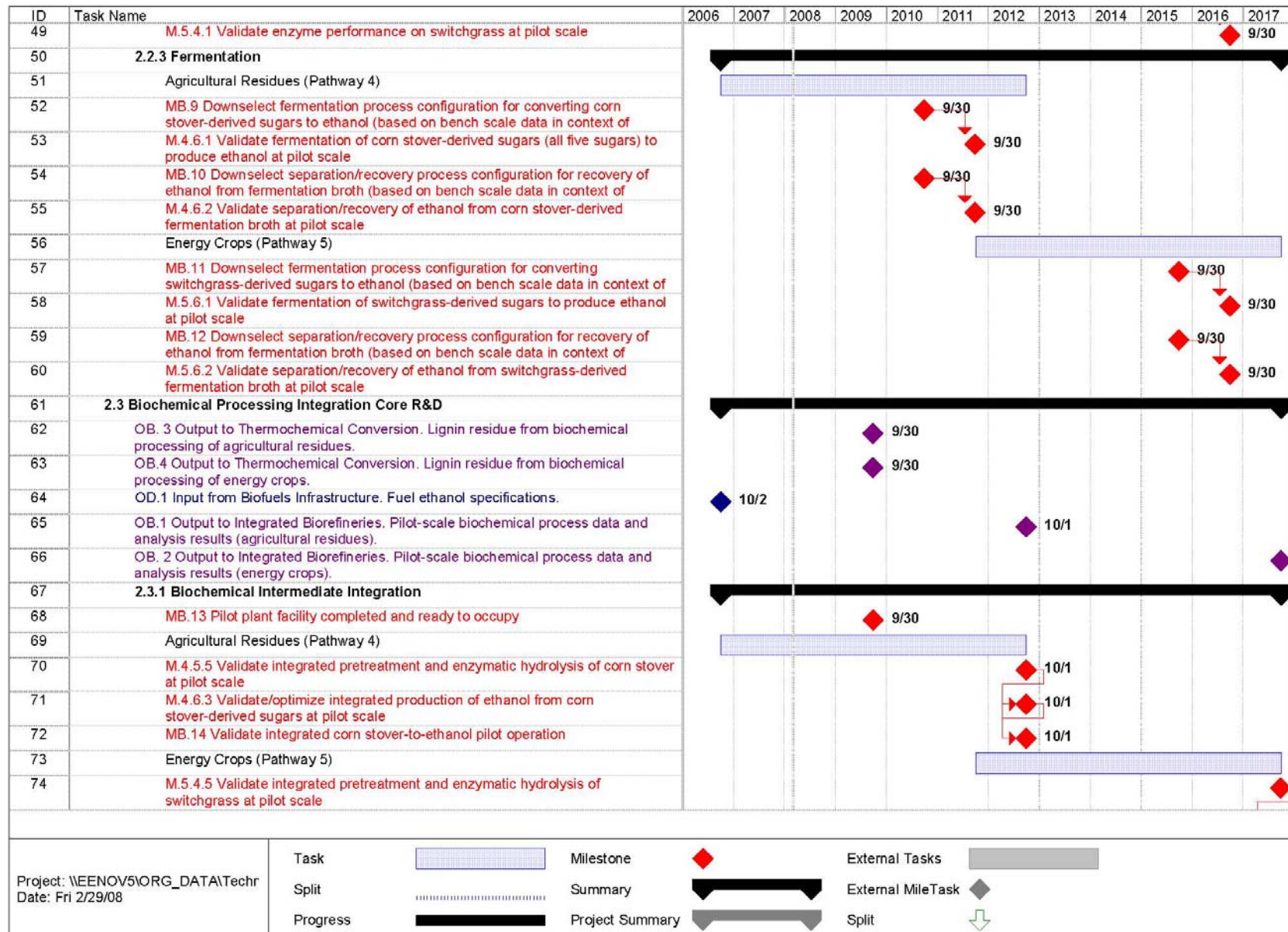

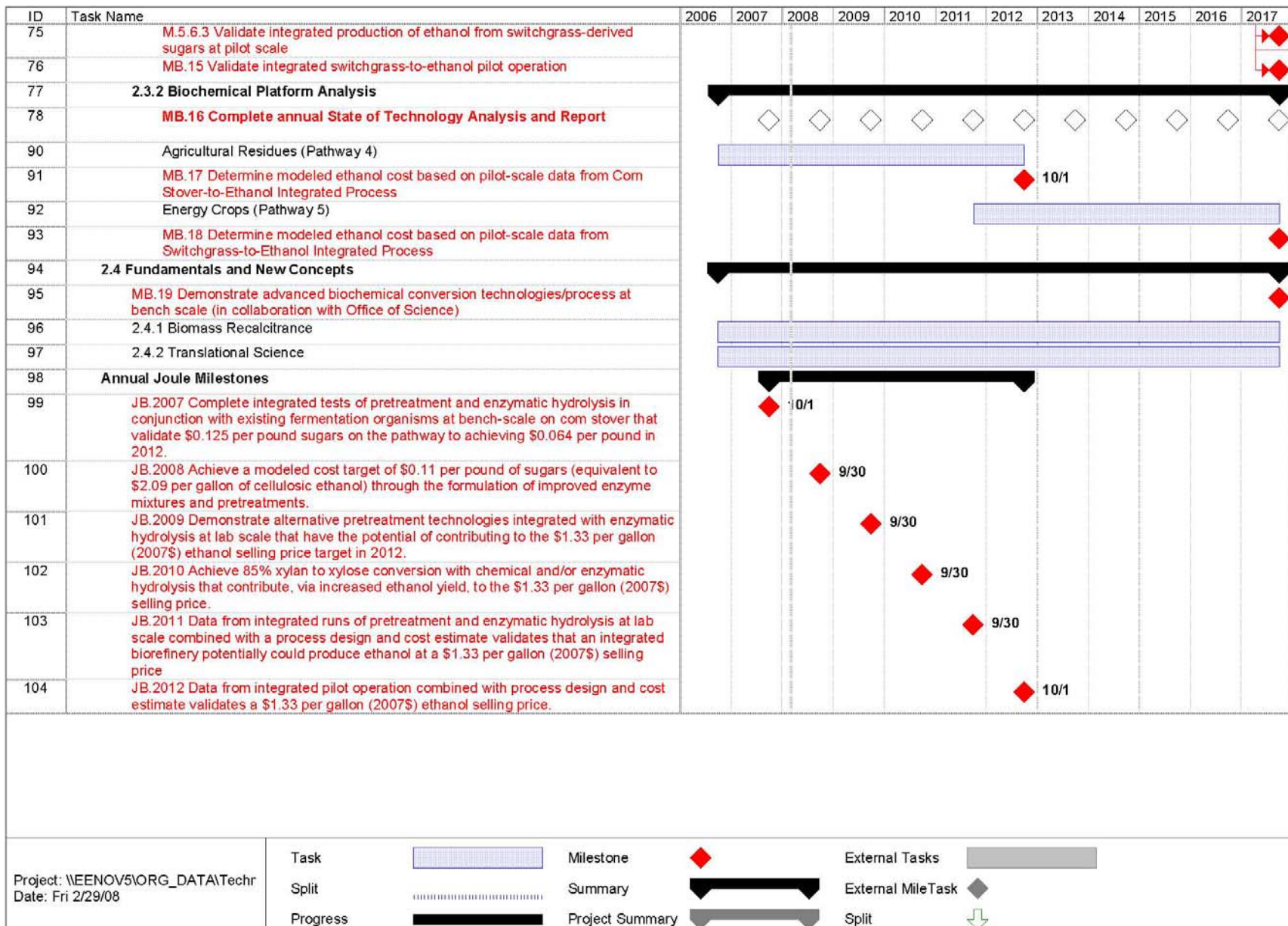

3.2.2 THERMOCHEMICAL CONVERSION PLATFORM

The Thermochemical platform develops technology to convert biomass to fuels, chemicals and power via thermal and chemical processes such as gasification, pyrolysis and other non-biochemical processes. Intermediate products include clean synthesis gas or syngas (a mixture of primarily hydrogen and carbon monoxide, resulting from gasification), bio-oil (liquid product from pyrolysis), and gases rich in methane or hydrogen. These intermediate products can then be upgraded to products such as ethanol, other alcohols, green-gasoline, green-diesel, ethers, synthetic natural gas, chemical products, or high-purity hydrogen, or may be used directly for heat and power generation. It is important to recognize that some of these products are direct substitutes for fossil-fuel-based intermediates and products and therefore, can likely use portions of the existing fossil fuel processing and distribution infrastructure.

Based on the current stage of development of thermochemical conversion technologies, gasification provides higher potential for near-term deployment, while pyrolysis will be important in meeting longer-term biofuels goals. The Program, therefore, has prioritized gasification R&D in its near-term efforts. Pyrolysis technologies are being evaluated by the Program and efforts may increase in the future based on the outcome. Pyrolysis presents the additional benefit of leveraging investments in the petroleum industry since its intermediate product of bio-oil can, after stabilization, be potentially used as a petroleum refinery feedstock.

Thermochemical conversion technology options can maximize biomass resource utilization to produce biofuels because they can more easily convert low-carbohydrate biomass materials such as forest and wood resources than biochemical conversion options. In addition, they can convert the lignin-rich non-fermentable residues from biochemical conversion processes. Advanced conversion technology scenarios rely on considerable yield enhancements achievable by combining the two conversion technologies into an integrated biorefinery; such integration would maximize the liquid fuel yield per ton of biomass and enable higher overall energy efficiencies by allowing integration of high-efficiency heat and power production systems, such as combined cycle gas turbines or fuel cells.

Thermochemical Platform Unit Operations

(i) Gasification Process Description

A potential thermochemical gasification basic process flow for converting biomass to ethanol is shown in Figure 3-16; the figure includes the potential for integration with biochemical conversion. Process details for the combustion of biochemical process residues and for a gasification route to mixed alcohols are available in recent design reports.^{1,2}

¹ "Lignocellulosic Biomass to Ethanol Process Design and Economics Utilizing Co-Current Dilute Acid Prehydrolysis and Enzymatic Hydrolysis for Corn Stover," NREL/TP-510-32438, 2002.

² "Thermochemical Ethanol via Indirect Gasification and Mixed Alcohol Synthesis of Lignocellulosic Biomass," NREL/TP-510-41168, April 2007.

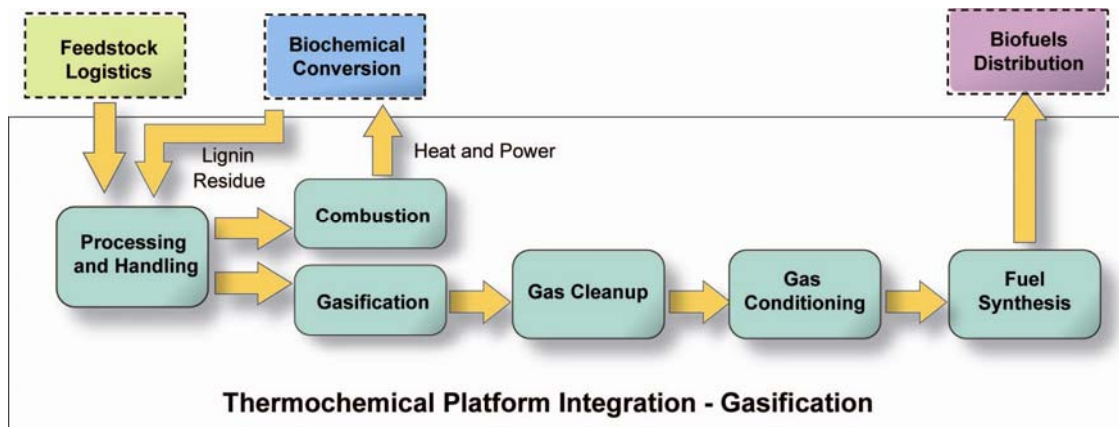

Figure 3-16: Thermochemical Gasification Route for Biomass to Biofuels

Feed Processing and Handling: The feedstock interface addresses the main biomass properties that affect the long-term technical and economic success of a thermochemical conversion process: moisture content, fixed carbon and volatiles content, impurity concentrations, and ash content. High moisture and ash content reduce the usable fraction of delivered biomass. Therefore, maximum gasification system efficiencies are possible with dry, low-ash biomass; however, effective technologies for conversion of wet residues are also possible.

Gasification: Biomass gasification is a complex thermochemical process that begins with the thermal decomposition of a lignocellulosic fuel. This is followed by partial oxidation or reforming of the fuel with a gasifying agent—usually air, oxygen, or steam—to yield raw syngas. The raw gas composition and quality are dependent on a range of factors, including feedstock composition, feedstock water content, type of gasification reactor, gasification agents, stoichiometry, temperature, pressure, and the presence or lack of catalysts.

Gas Cleanup: Gas cleanup is the removal of contaminants from biomass gasification product gas. It generally involves an integrated multi-step approach which varies depending on the intended end use of the product gas. However, gas cleanup normally entails removing or reforming tars and acid gas, ammonia scrubbing, capturing alkali metal, and removing particulates.

Gas Conditioning: Typical gas conditioning steps include sulfur polishing (to reduce levels of hydrogen sulfide to acceptable amounts for fuel synthesis) and water-gas shift (to adjust the final hydrogen-carbon monoxide ratio for optimized fuel synthesis).

Fuel Synthesis: Comprehensive cleanup and conditioning of the raw biomass gasification product gas yields a “clean” syngas composed of carbon monoxide and hydrogen in a given ratio. This gas can be converted to mixed alcohols or Fischer-Tropsch hydrocarbons. The production of fungible liquid transportation fuels from these intermediates also yields value-added bio-based byproducts and chemicals. The fuel synthesis step is exothermic, so heat recovery is essential to maximize process efficiency.

(ii) Pyrolysis Process Description

The thermochemical pyrolysis process for converting biomass fuels to renewable gasoline or diesel is shown in Figure 3-17 below.

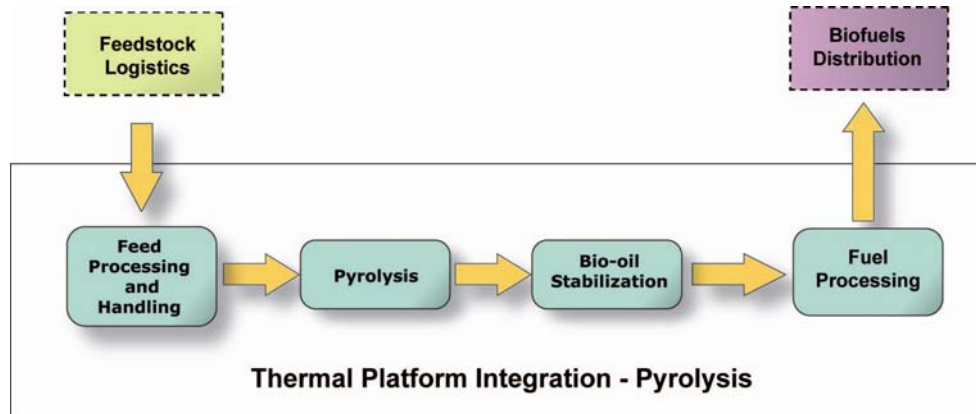

Figure 3-17: Thermochemical Pyrolysis Route for Biomass to Biofuels

Feed Processing and Handling: Similar to gasification, the feedstock interface for pyrolysis addresses the main biomass properties that affect the long-term technical and economic success of a thermochemical conversion process: moisture content, elemental composition, impurity concentrations, and ash content. High moisture and ash content reduce the usable fraction of delivered biomass. So-called “fast” pyrolysis processes require dry feedstocks, while hydrothermal approaches can use moist biomass.

Pyrolysis: Pyrolysis is the thermal decomposition of biomass in the absence of oxygen to produce a bio-oil intermediate that superficially resembles No. 4 fuel oil. These reactions occur at lower reaction temperatures than gasification and produce primarily liquid products instead of gases. Several types of fast pyrolysis or hydrothermal processes can be used to produce the bio-oil, and its characteristics such as oxygen content or viscosity depend on the processing conditions.

Bio-Oil Cleanup and Stabilization: Cleanup and conditioning of the bio-oil converts it into a product suitable for feeding to a petroleum refinery. Cleanup consists of removing water, particulates, and ash by filtration and similar methods. Stabilization involves hydrotreating and similar thermal processing to reduce the total oxygen content of the intermediate and its acid number.

Fuel Processing: The cleaning and stabilization of the bio-oil yields a feedstock suitable for use in a petroleum refinery. Hydrocracking processes convert the feedstock to gasoline and diesel hydrocarbon fuels using marginally modified technologies employed by existing refiners. This processing leverages the economies of scale and the investments of the petroleum industry and provides biofuel alternatives to ethanol.

Thermochemical Platform Interfaces

Feedstock Logistics Interface: The Feedstock Logistics platform provides preprocessed feedstock that meets the requirements (composition, quality, size, etc.) as defined by the specific biochemical conversion process configuration. Close coordination between the Feedstock Logistics and Thermochemical Conversion platforms is required to supply adequate feedstock in an appropriate form to the biorefinery.

Biochemical Conversion Process Interface: Lignin and other byproducts/residues of the biochemical conversion process can be used to produce the electricity required for the production process. Lignin can also be thermochemically converted to fuels and chemicals.

Biofuels Distribution Interface: The next step in the biomass-to-biofuels supply chain is the distribution of the biofuels produced.

3.2.2.1 THERMOCHEMICAL PLATFORM SUPPORT OF PROGRAM STRATEGIC GOALS

The Thermochemical platform's strategic goal is to *develop technologies for converting feedstocks into cost-competitive commodity liquid fuels, such as ethanol, as well as bioproducts and biopower.*

The Thermochemical platform directly addresses and supports production of fuels in the Agricultural Residues Processing, Energy Crops Processing, and Forest Resources Processing pathways. It also indirectly supports the production of bioproducts from these pathways. Thermochemical conversion technologies provide options for improving the economic viability of the developing bioenergy industry by their ability to convert whole biomass as well as the fractions of the biomass resources that are not amenable to biochemical conversion technologies (e.g. lignin-rich process residues and other low-carbohydrate feedstocks or process intermediates).

3.2.2.2 THERMOCHEMICAL PLATFORM SUPPORT OF PROGRAM PERFORMANCE GOALS

The overall performance goal of the Thermochemical platform is to reduce the estimated mature technology processing cost for converting cellulosic feedstocks to ethanol to \$0.82 per gallon by 2012³ and \$0.60 per gallon by 2017 (2007\$) based on integrated pilot-scale data. The overall performance goal is the same for the pyrolysis route based on the energy output.

The performance goals for the pathways under investigation are as follows:

Agricultural Residues Pathway

- By 2009 (Q4), validate integrated gasification of lignin derived from corn stover and wheat straw to produce clean syngas at pilot scale.

³ See Figure 2.2-9 for additional information.

- By 2010 (Q4), validate integrated gasification of corn stover and wheat straw to produce clean syngas at pilot scale.
- By 2012, validate integrated production of ethanol from mixed alcohols produced from corn-stover- and wheat-straw-based (lignin or biomass) syngas at pilot scale.
- By 2015, validate integrated production of biomass to gasoline and diesel via pyrolysis routes at pilot plant scale.

Energy Crops Pathway

- By 2009 (Q4), validate integrated gasification of hybrid poplar- and switchgrass-derived lignin to produce clean syngas at pilot scale
- By 2010 (Q4), validate integrated gasification of hybrid poplar and switchgrass to produce clean syngas at pilot scale
- By 2012, validate integrated production of ethanol from mixed alcohols produced from hybrid poplar- and switchgrass-based (lignin or biomass) syngas at pilot scale
- By 2012, validate integrated production of biomass to gasoline and diesel via pyrolysis routes at pilot plant scale for woody biomass

A detailed design case for biomass pyrolysis technology options is in progress. This information will be used to identify additional cost and performance targets based on the pathway described above and will be included in future updates of this MYPP.

3.2.2.3 THERMOCHEMICAL PLATFORM TECHNICAL CHALLENGES AND BARRIERS

Tt-A. Feeding Dry Biomass: In the near term, there are no significant barriers to feeding and handling dry wood or agricultural resources in atmospheric systems provided they are of a relatively uniform particle size. In the longer term, there is a need for improvements in the processing and feeding of dry biomass including densification and removal of problematic chemical contaminants (e.g. alkali species). Demonstrating reliable feeding of dry biomass into pressurized systems is also needed.

Tt-B. Feeding or Drying Wet Biorefinery Streams: There is a need to understand the costs and trade-off of drying or feeding wet biorefinery residues such as wet lignin-rich fermentation residues. Innovative dryer designs capable of utilizing low-value process heat will be important to the integrated biorefinery.

Tt-C.⁴ Gasification of Wood, Biorefinery Residue Streams and Low Sugar Content Biomass: There is a need to understand the fuel chemistry and physical handling properties of other biomass feedstocks, minor byproducts and co-products, and biorefinery residual solids. This includes developing an understanding of gasification options and their chemistries for materials including wood, spent pulping liquors, agricultural residues that are high in minerals, high-lignin feedstocks and residues, and high-moisture organic residues.

Tt-E. Pyrolysis of Biomass: Development of new methods to control the pyrolytic pathways to bio-oil intermediates in order to increase product yield and recovery is needed. These product

⁴ Barrier Tt-D Wet Gasification of Biorefinery Residues from previous MYPP was combined into Tt-C.

quality improvements are important to achieving the stability specifications of the resulting bio-oil and may also result in more favorable chemistry for processing in conventional petroleum refineries. New methods to clean and stabilize the bio-oil intermediate are also needed to ensure the product is compatible with refining technology. These advances include improved hydrotreating catalysts and techniques for processing the bio-oil.

Tt-F. Syngas Cleanup and Conditioning: There is a near-term need for gas cleaning and conditioning technology that can cost-effectively remove contaminants such as tar, particulates, alkali, and sulfur. The interactions between the catalysts used for gas cleanup and conditioning, and the gasification conditions and feedstock are not well understood. These interactions require careful attention to trace contaminants.

Tt-G. Fuels Catalyst Development: The production of mixed alcohols from syngas has been known since the beginning of the last century; however, the commercial success of mixed alcohol synthesis has been limited by poor selectivity and low product yields. Improved catalysts with increased productivity and selectivity to higher alcohols are required to enable viable capital costs. The development of robust catalysts for the upgrading of pyrolysis oil for the production of liquid transportation fuels is critical to the economic viability of the process. The catalysts must afford high selectivity to the desired end product, be robust with respect to the pyrolysis oil impurities, and have high conversion rates and long lifetimes. Improvement to the robustness of hydrocracking catalysts for producing hydrocarbon biofuels via pyrolysis is also needed.

Tt-H. Validation of Syngas Quality: Syngas quality specifications for production of liquid fuel products like methanol/dimethyl ether (MeOH/DME), mixed alcohols and hydrocarbon liquids are reasonably well known. However, validation that syngas from biomass can meet the rigorous quality specification needed for the production of liquid fuels via catalytic synthesis is still needed.

Tt-I. Sensors and Controls: Effective process control will be needed to maintain plant performance and regulate emissions at target levels with varying load, fuel properties, and atmospheric conditions. Commercial control systems need to be developed for thermochemical processes and systems.

3.2.2.4 THERMOCHEMICAL PLATFORM APPROACH FOR OVERCOMING CHALLENGES AND BARRIERS

The approach for overcoming biomass thermochemical conversion technical challenges and barriers is outlined in the Thermochemical platform's work breakdown structure (WBS). The platform WBS is organized around four key tasks, as shown in Figure 3-18.

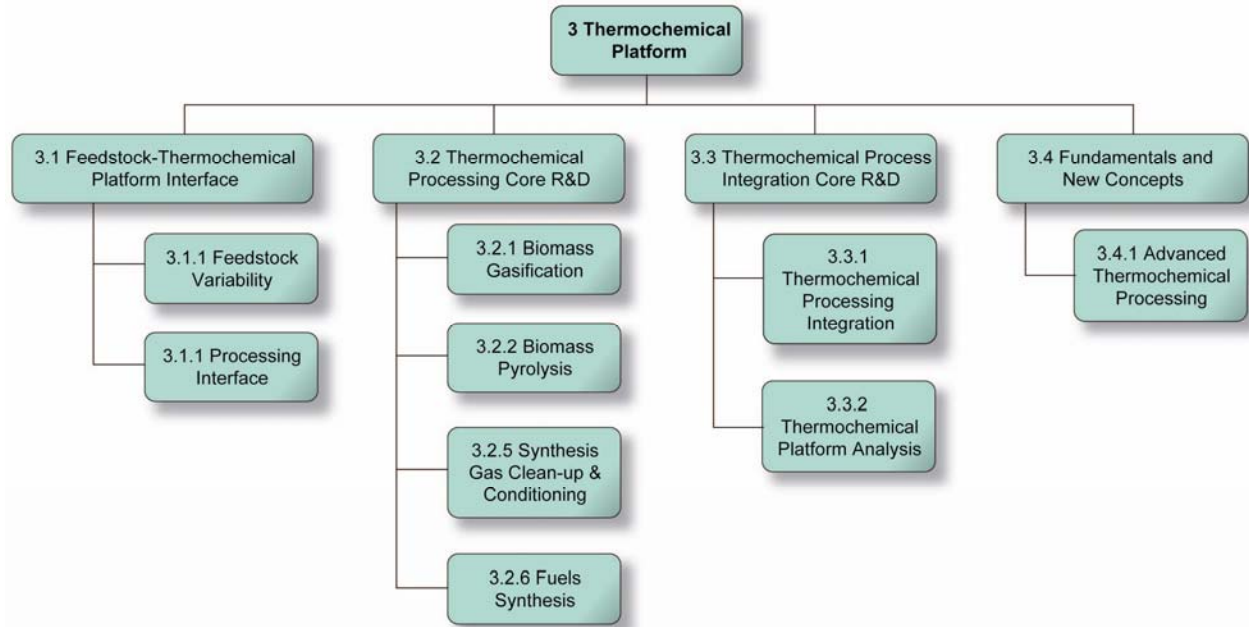

Figure 3-18: Work Breakdown Structure for Thermochemical Platform Core R&D

The current efforts are focused on gasification of woody biomass, low-quality agricultural residues, and lignin-rich biorefinery residues. These R&D activities include fundamental kinetic measurements, micro-activity catalyst testing, bench-scale thermochemical conversion studies, pilot-scale validation of tar-reforming catalyst performance, mixed alcohol catalyst development, and pilot-scale demonstration of integrated biomass gasification mixed alcohol synthesis. A lower level of effort is directed at pyrolysis of similar feedstocks including basic studies of catalytic and chemical mechanisms for improving yields and quality of bio-oils and catalysis for stabilizing the intermediate. Core research, which addresses the key technical barriers, is performed by national laboratories, industry and universities.

The R&D approach of each Thermochemical WBS task element is described below, while Table 3-6 summarizes each task element's work as it relates to specific platform barriers and biorefinery pathways.

WBS 3.1. Feedstock-Thermochemical Platform Interface

For biorefineries, it is important that feedstock requirements be met while preparation requirements are minimized to reduce costs. This requires balancing the cost of plant-gate feedstock with the handling and processing required for reliable operation. The Thermochemical platform is collaborating with the Feedstock platform to overcome the challenges and barriers associated with the interface between feedstock logistics and thermochemical conversion systems. Research activities are also focused on handling, processing and feeding that occurs within the biorefinery plant boundaries.

WBS 3.2. Thermochemical Processing Core R&D (Barriers Tt-C, E, F, G)

In order to fully realize the benefits of an integrated biorefinery, robust and cost-effective biomass thermal conversion processes are under development that can convert a variety of biomass materials to suitable clean intermediates for subsequent conversion to fuels. Activities

are focused on developing cost-effective thermochemical conversion technologies that can produce clean syngas, stable pyrolysis oils and downstream fuels and/or products synthesis catalysts.

WBS 3.3 Thermochemical Processing Integration Core R&D (Barriers Tt-H, I)

Investigating thermochemical conversion technologies together with downstream fuel synthesis identifies the issues and opportunities of integration. In addition, the effect of feed and process variations throughout the process must be understood to ensure robust, efficient biorefineries. One immediate goal is to demonstrate that the improved tar cracking and reforming catalysts have the potential to consolidate high-temperature chemical transformations, thereby increasing thermodynamic efficiency as well as reducing the cost and risk of gasification-based process technology. Fundamental research is focused on developing advanced consolidated processes that maximize the conversion of biomass to fuels by optimizing biomass deconstruction into pretreated/preconditioned fractions to maximize yields of highly selective thermal transformations. Process intensification and consolidation drive the economics that significantly reduce capital and operating costs to minimize production costs.

WBS 3.4 Fundamentals and New Concepts

A fundamental understanding of the factors controlling thermochemical conversion is needed to be able to develop new or improved technologies that increase efficiency and reduce cost. As feedstock prices increase due to supply and demand, decreased conversion costs will allow the industry to utilize higher priced feedstocks.

Table 3-6: Thermochemical Platform Core R&D Task Summary

WBS Element	Description	Barrier(s) Addressed ⁵	Pathway(s) Addressed
3.1 Feedstock-Thermochemical Platform Interface			
3.1.1 Feedstock Variability	<p>Understand feedstock variability and options for mitigating impacts on downstream processing 2007-2012</p> <ul style="list-style-type: none"> Develop feedstock-specific chemical and physical specifications for woody biomass, biorefinery residues, agricultural residues and herbaceous energy crops <p>2013-2017</p> <ul style="list-style-type: none"> Continue to develop chemical and physical specifications for new or emerging feedstocks 	<p>Tt-A: Feeding Dry Biomass Tt-C: Gasification of Wood, Biorefinery Residue Streams and Low Sugar Content Biomass</p>	<ul style="list-style-type: none"> Agricultural Residue Processing Energy Crops Processing
3.1.2 Processing Interface	<p>Define and coordinate the interface between thermochemical conversion processes and feedstock source 2007-2012</p> <ul style="list-style-type: none"> Develop feedstock handling systems for wet process residues, as received from biochemical conversion process Develop feedstock handling systems for dry biomass, as delivered from feedstock logistics system <p>2013-2017</p> <ul style="list-style-type: none"> Continue efforts for new or emerging feedstocks 	<p>Tt-B: Feeding or Drying Wet Biorefinery Streams</p>	<ul style="list-style-type: none"> Agricultural Residue Processing Energy Crops Processing
3.2 Thermochemical Processing Core R&D			
3.2.1 Biomass Gasification	<p>Identify cost-effective, feedstock-specific gasification options with respect to chemistry and reactor design 2007-2012</p> <ul style="list-style-type: none"> Optimize gasifier design and conditions (quality, composition, efficiency) for syngas production from cellulosic feedstocks and process residues Maximize syngas production efficiency while minimizing tar and hydrocarbon contaminants in raw product gas Optimize wet gasifier system design and conditions (quality, composition, efficiency) for clean product gas production from high- moisture (< 20% solids) feedstocks and residues Optimize gasifier design and conditions (quality, composition, efficiency) for syngas production from black liquor <p>2013-2017</p> <ul style="list-style-type: none"> Increase carbon conversion and thermodynamic efficiencies 	<p>Tt-C: Gasification of Wood, Biorefinery Residue Streams and Low Sugar Content Biomass</p>	<ul style="list-style-type: none"> Agricultural Residue Processing Energy Crops Processing

⁵ see section 3.2.2.3 for description

3.2.2 Biomass Pyrolysis	<p>Identify cost-effective, feedstock-specific pyrolysis pathways to improve bio-oil quality and increase product yield.</p> <p>2007-2012</p> <ul style="list-style-type: none"> Optimize pyrolysis system design and conditions for bio-oil production Develop improved catalyst and processing techniques to remove oxygen from raw bio-oil <p>2013-2017</p> <ul style="list-style-type: none"> Develop catalytic or chemical processes to improve product yields and selectivities Develop improved techniques for removing particulates from bio-oil 	Tt-E: Pyrolysis of Biomass	<ul style="list-style-type: none"> Agricultural Residue Processing Energy Crops Processing
3.2.5 Synthesis Gas Clean-up & Conditioning	<p>Develop advanced catalysts and systems for syngas cleanup and conditioning</p> <p>2007-2012</p> <ul style="list-style-type: none"> Develop advanced integrated system designs for clean gas production using membranes and circulating beds of catalyst/adsorbent Develop improved gas cleanup and conditioning catalysts with improved tar reforming efficiency, longer life, and higher tolerance for sulfur and chlorine Demonstrate catalyst performance and lifetime, and optimize process conditions, at pilot scale for woody feedstocks and selected agricultural and biorefinery residues <p>2013-2017</p> <ul style="list-style-type: none"> TBD based on progress 	Tt-F: Syngas Cleanup and Conditioning Tt-H: Validation of Syngas Quality	<ul style="list-style-type: none"> Agricultural Residue Processing Energy Crops Processing
3.2.6 Fuels Synthesis	<p>Develop advanced catalysts and systems for cost-effective fuels synthesis from syngas</p> <p>2007-2012</p> <ul style="list-style-type: none"> Develop improved mixed alcohol synthesis catalysts with higher activity, increased CO conversion, and improved CO selectivity to alcohols Optimize alcohol synthesis catalyst reactor design and conditions for production of mixed alcohols from syngas derived from woody biomass Develop improved hydrocracking processing approaches to convert stabilized bio-oil to gasoline and diesel fuels <p>2013-2017</p> <ul style="list-style-type: none"> Develop catalysts and systems for other selected fuel products 	Tt-G: Fuels Catalyst Development	<ul style="list-style-type: none"> Agricultural Residue Processing Energy Crops Processing
3.3 Thermochemical Process Integration Core R&D			
3.3.1 Thermochemical Processing Integration	<p>Define and coordinate the interfaces within the thermochemical conversion platform</p> <p>2007-2012</p> <ul style="list-style-type: none"> Integrate/consolidate feedstock handling, gasification, gas cleanup and conditioning, and fuel synthesis unit operations to optimize yield and efficiency Validate targeted integrated process performance in pilot plant scale system. <p>2013-2017</p> <ul style="list-style-type: none"> Investigate fundamental thermochemical conversion to enable alternative processes that will help erase the lines between gasification and pyrolysis as separate technology options 	Tt-H: Validation of Syngas Quality Tt-I: Sensors and Controls	<ul style="list-style-type: none"> Agricultural Residue Processing Energy Crops Processing
3.3.2 Thermochemical Platform Analysis	<p>Develop and employ conceptual models to demonstrate the feasibility of various process design concepts and identify integration issues</p> <p>2007-2012</p> <ul style="list-style-type: none"> Prepare annual State of Technology estimates to show progress to the 2012 performance target Validate 2012 performance target using pilot plant data and baseline process design 		<ul style="list-style-type: none"> Agricultural Residue Processing Energy Crops Processing

	<p>and mature technology cost estimate.</p> <ul style="list-style-type: none"> • Complete conceptual design report for biomass pyrolysis to fuels process scenario <p>2013-2017</p> <ul style="list-style-type: none"> • Complete conceptual design report on integrated biochemical/thermochemical process scenario for advanced biorefinery • Complete conceptual design for advanced thermochemical conversion technology options 		<ul style="list-style-type: none"> • Forest Resources Processing
3.4 Fundamentals and New Concepts			
3.4.1 Advanced Thermochemical Processing	<p>Develop and apply scientific and engineering approaches for enhanced understanding of the basic mechanisms in thermochemical biomass conversion</p> <p>2007-2017</p> <ul style="list-style-type: none"> • Identify promising catalytic gasification and pyrolysis processes • Develop higher-value uses for lignin residues <p>2013-2017</p> <ul style="list-style-type: none"> • Evaluate most promising catalysts for catalytic gasification • Identify the best process for thermochemical use of lignin • Investigate selective thermochemical fractionation of biomass and selective transformation of the intermediate fractions 		<ul style="list-style-type: none"> • Agricultural Residue Processing • Energy Crops Processing • Forest Resources Processing

3.2.2.5 PRIORITIZING THERMOCHEMICAL CONVERSION PLATFORM BARRIERS

The Thermochemical platform has prioritized its efforts in overcoming technical barriers based on analysis results illustrated in Figure 3-19. Similar analysis for the pyrolysis process concept is under development and will be reported in future updates of the MYPP.

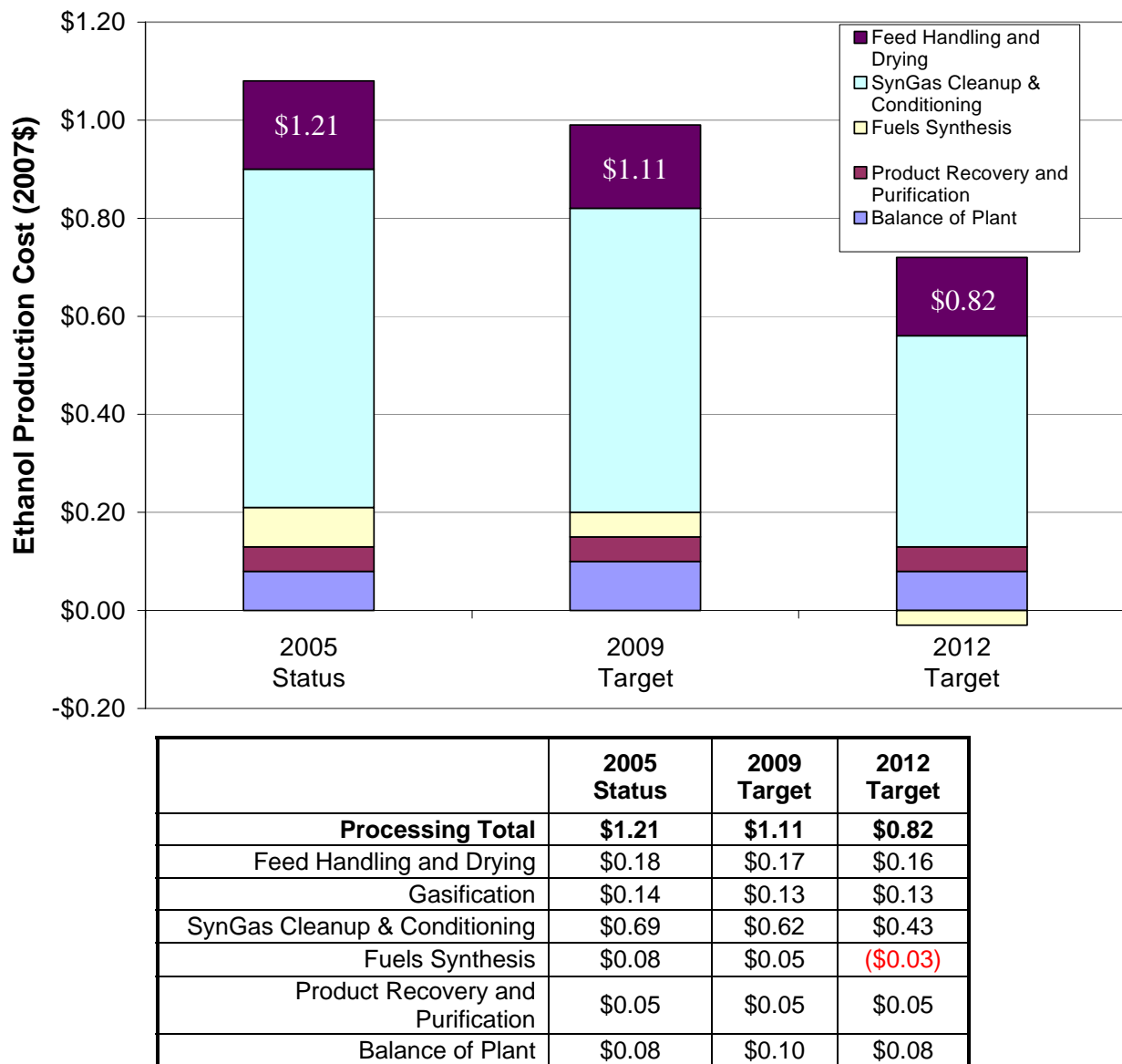

Figure 3-19: Thermochemical Conversion of Hybrid Poplar to Ethanol (\$/gal in 2007\$)

The figure shows that the largest potential reduction in ethanol processing cost can be obtained with technology development in the synthesis gas clean up and conditioning area, while a total potential reduction of 46% can be achieved with improvements in all six areas. Research and development activities are focused to impact this cost.

Detailed information on the technical performance targets that form the basis for the conceptual thermochemical conversion systems designs and cost estimates are provided in Appendix B, Table B-5. The status and targets are based on gasification of hybrid poplar, syngas cleanup, and

mixed alcohol synthesis and recovery. The State of Technology is a modeled production cost at 2,000 dry tons feedstock/day using data from NREL bench scale thermochemical conversion R&D.

3.2.2.6 THERMOCHEMICAL PLATFORM MILESTONES AND DECISION POINTS

The key Thermochemical platform milestones, inputs/outputs and decision points to complete the tasks described in Section 3.2.2.4 are summarized in the chart in Figure 3-20.

The highest level milestones serve as the performance goals (listed in section 3.2.2.2) for the thermochemical conversion platform. These performance goals represent the culmination of work that has progressed from bench to individual pilot-scale operation to integrated pilot operation. Figure 3-20a lays out the full set of program-level milestones for the thermochemical conversion of corn stover to ethanol, showing the progression from bench to integrated pilot operation and the alignment with the thermochemical conversion platform tasks as defined by the WBS.

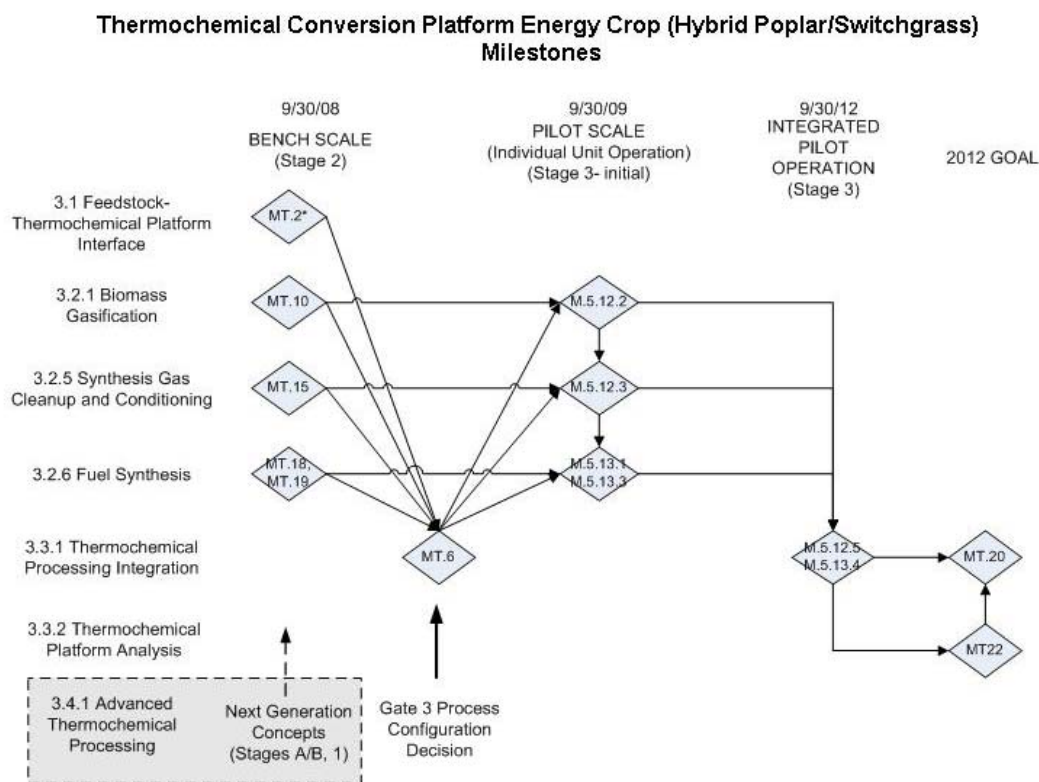

Figure 3-20a. Thermochemical Conversion Platform Corn Stover Milestones

The milestones and decision points, represented by diamonds in the diagram, are detailed in Figure 3-21. At each scale, the unit operations must meet the set of thermochemical performance metrics defined for the route, as detailed in Appendix B, Table B-5. The core R&D work on a particular process route is complete when an integrated pilot or prototype system has been successfully demonstrated and validated.

The figure shows how process development and scale-up for a particular route are planned and tracked as follows:

- Bench Scale
 - Column 1: Successful completion of bench scale work leads to down-selection of unit operation design and configuration for corn stover (in context of integrated process applicability)
- Gate 3 Stage Gate Review
 - Column 2: Formal decision (via Stage 3 Gate Review) to move to pilot scale operation with defined integrated process configuration for corn stover (based on bench scale data)
- Pilot Scale
 - Column 3: Validate individual unit operation performance for corn stover at pilot scale
 - Column 4: By 2012, validate integrated production of ethanol from mixed alcohols produced from corn-stover- and wheat-straw-based (lignin or biomass) syngas at pilot scale. (this is one of the thermochemical conversion performance goals listed in Section 3.2.2.2)
 - Column 5: Determine modeled ethanol cost based on data from integrated pilot operation

The following definitions apply to the programmatic milestones in Figure 3-21.

- **Downselect:** Based on bench scale evaluation of viable processes/technologies, select the process design configuration that will move forward for demonstration in an integrated pilot plant or prototype system.
- **Demonstrate:** At pilot scale and beyond, verify that the unit operations operate as designed and meet the complete set of performance metrics (individually and as an integrated system).
- **Validate:** At pilot scale and beyond, ensure the process/system meets desired expectations/original intent. Validation goes beyond just meeting all of the performance metrics; it is an assessment of whether the system actually fulfills/completes a portion of the program effort.

Figure 3-20: Thermochemical Core R&D Gantt Chart

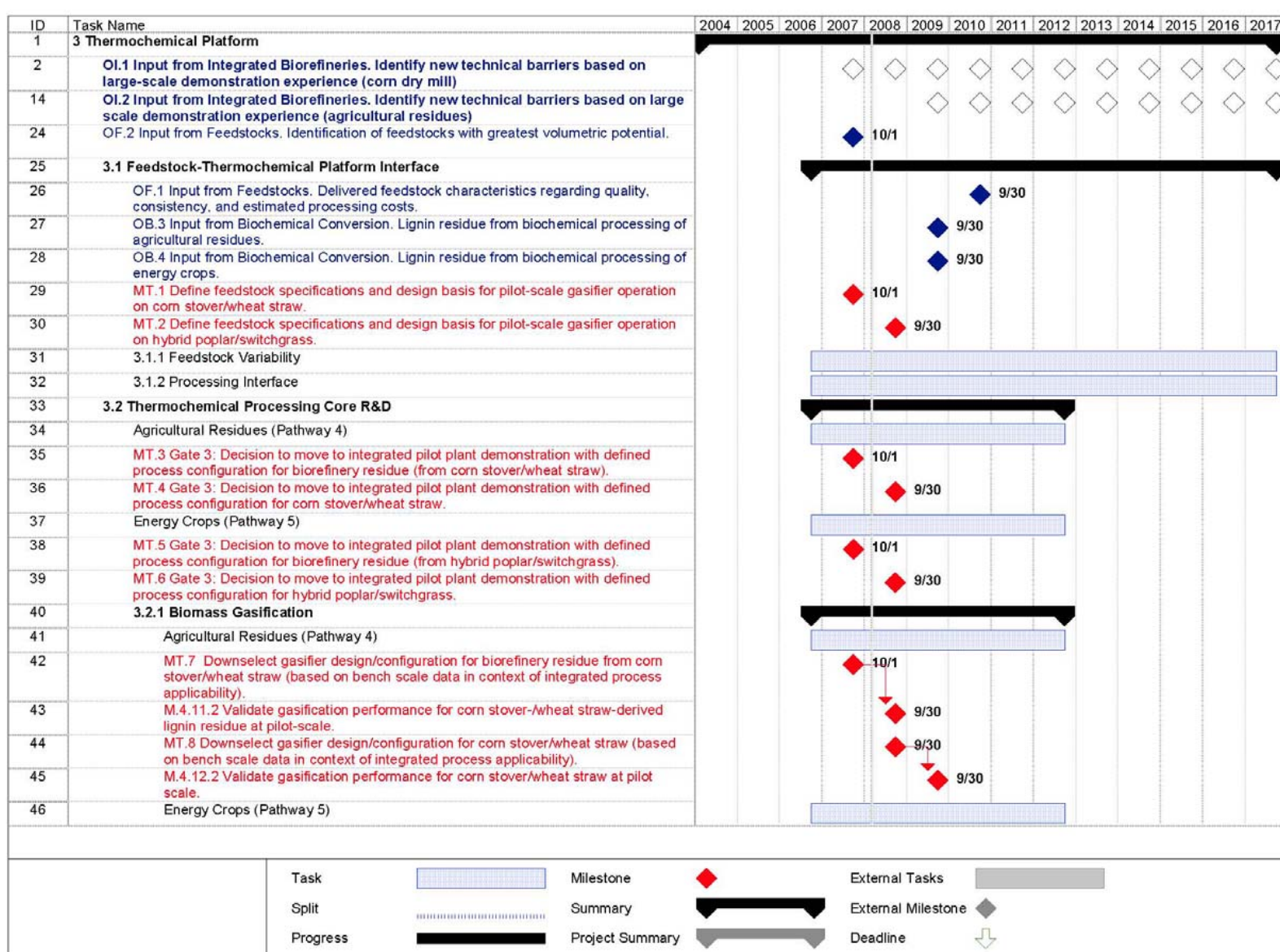

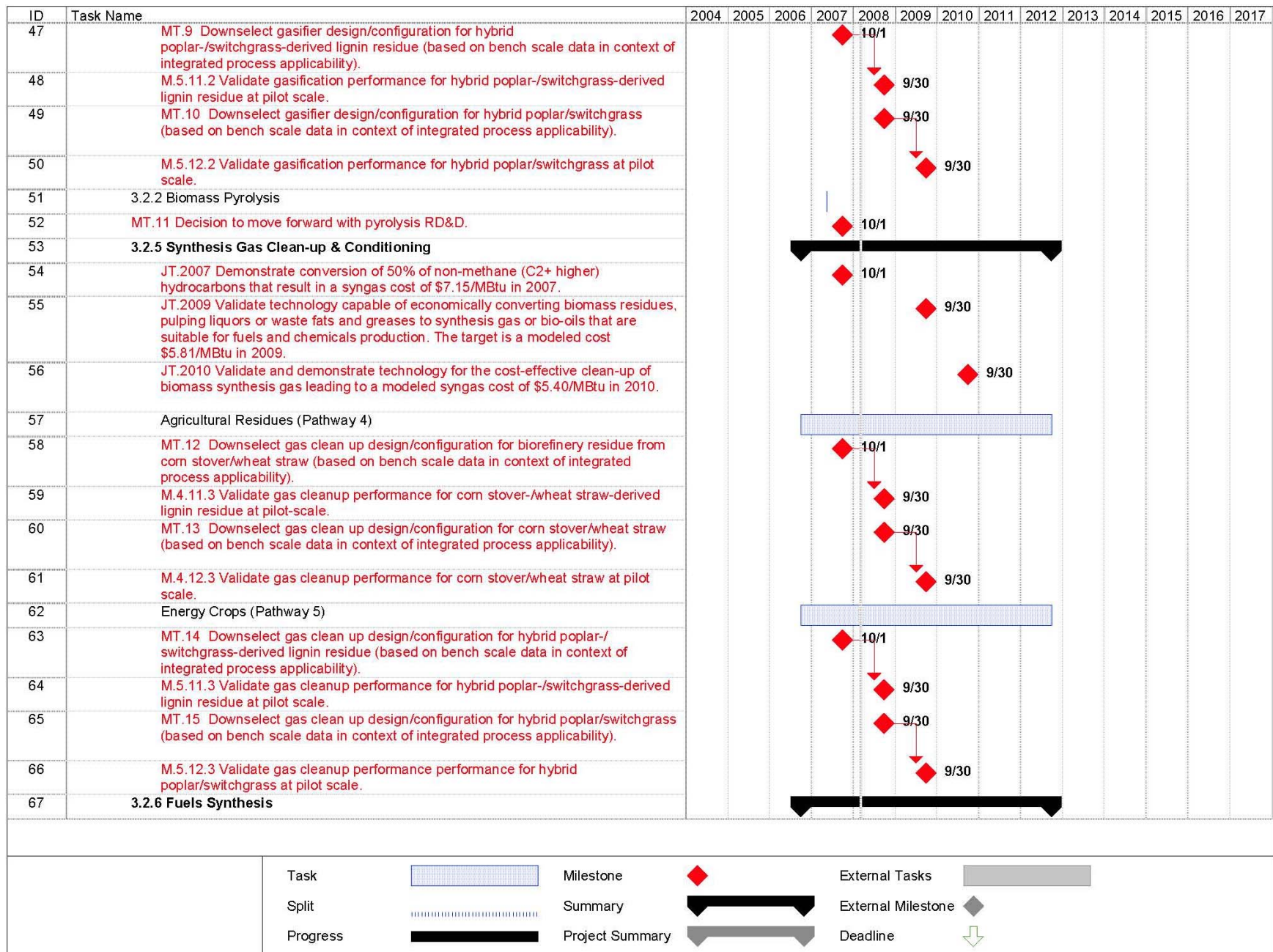

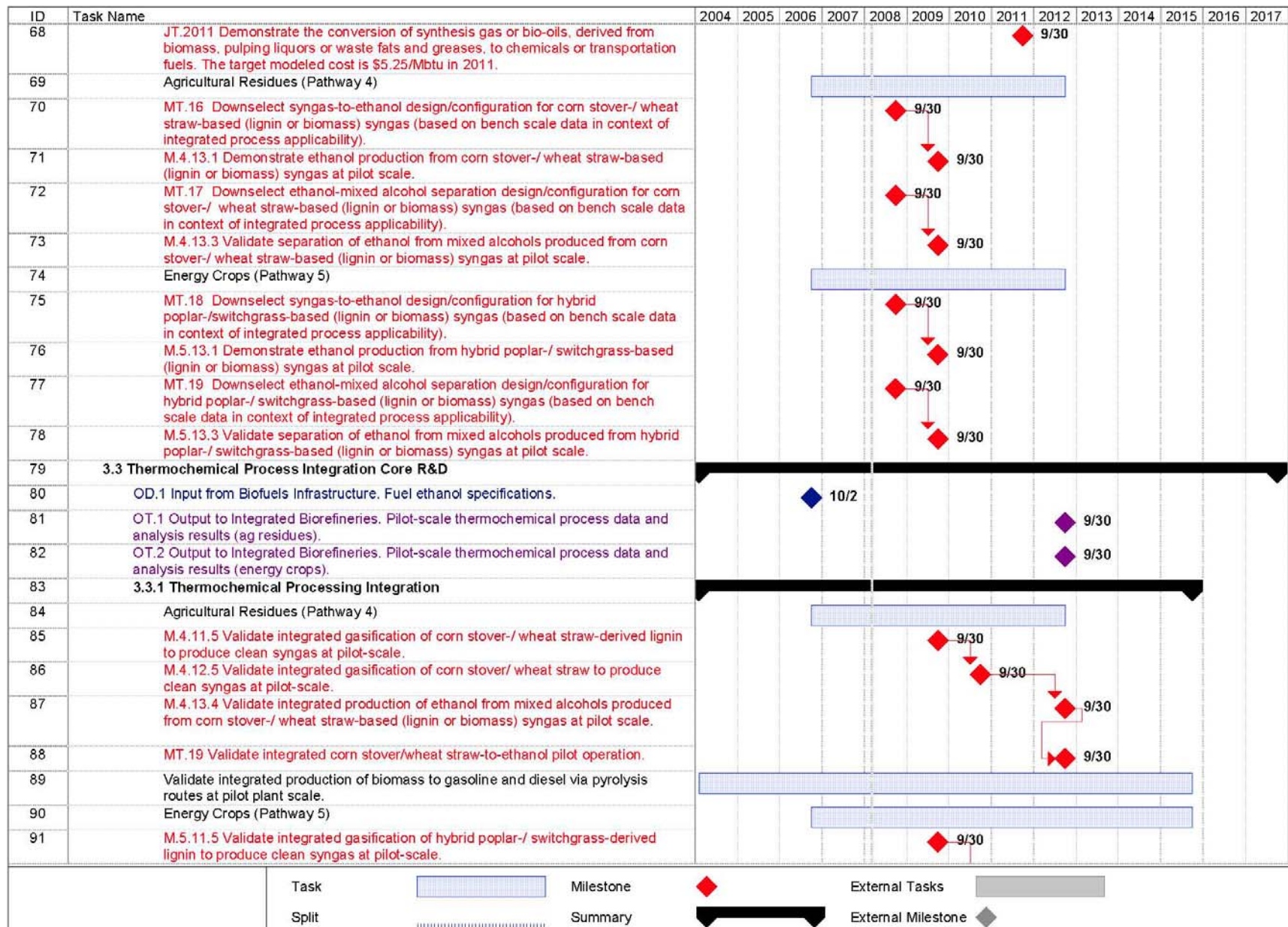

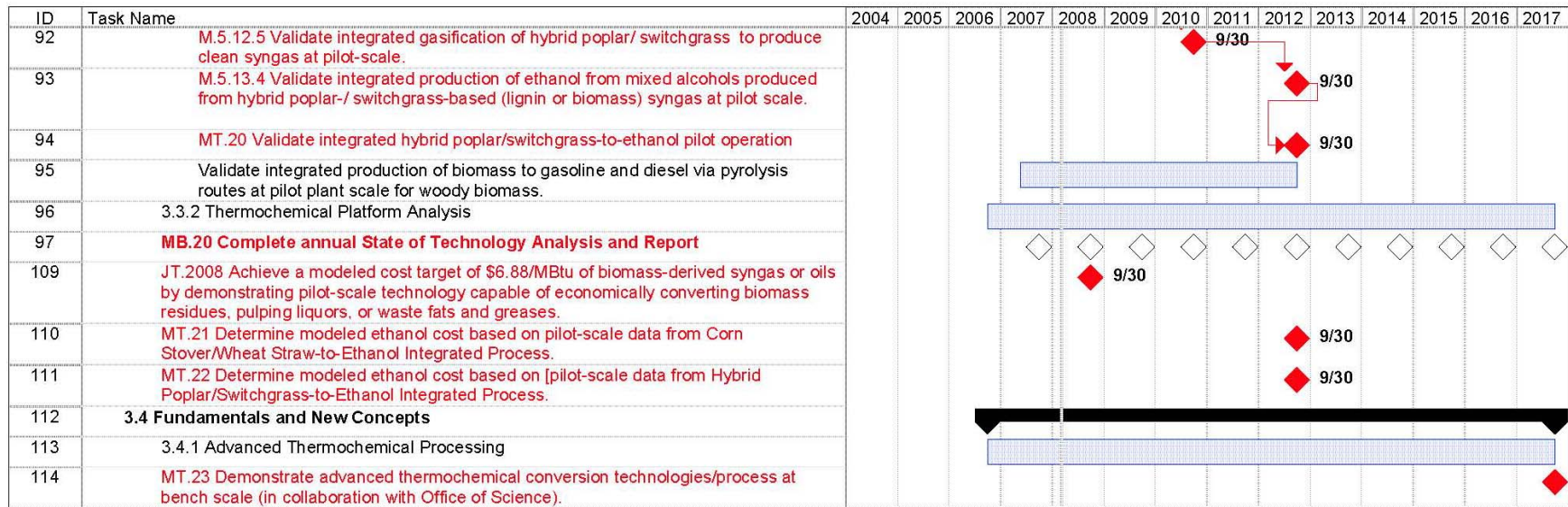

3.3 INTEGRATED BIOREFINERIES PLATFORM

The role of the Integrated Biorefineries platform is to establish cost-competitive integrated biorefineries through public-private partnerships by facilitating the commercialization and deployment of biomass technology. This platform focuses on the key issues involved in the validation and demonstration of integrated biorefinery systems. Demonstration and pioneer commercial-scale facilities will aid in overcoming barriers, promoting commercial acceptance, and ultimately reducing risks for future biorefineries.

The activities of the Integrated Biorefineries platform will ultimately contribute to all seven of the biorefinery pathways. Currently, the Program priority remains focused on enabling biorefineries to efficiently convert lignocellulosic biomass into ethanol and other biofuels. Cost-shared partnerships are essential to alleviating the high technical risk and capital investment of development. The Program competitively selected commercial demonstration projects and issued a request for proposals for smaller-scale validation projects that will contribute more broadly across the seven biorefinery pathways. The smaller-scale demonstration projects are expected to include additional feedstocks, processing technologies, non-ethanol biofuels and co-products.

The scope of the integrated biorefinery projects and their relationship to the three core R&D platforms (Feedstock and the two Conversion platforms) is illustrated in Figure 3-21. While project emphasis is on the biorefinery and its conversion processes, the business plan that provides the project vision also includes strong feedstock supply components.

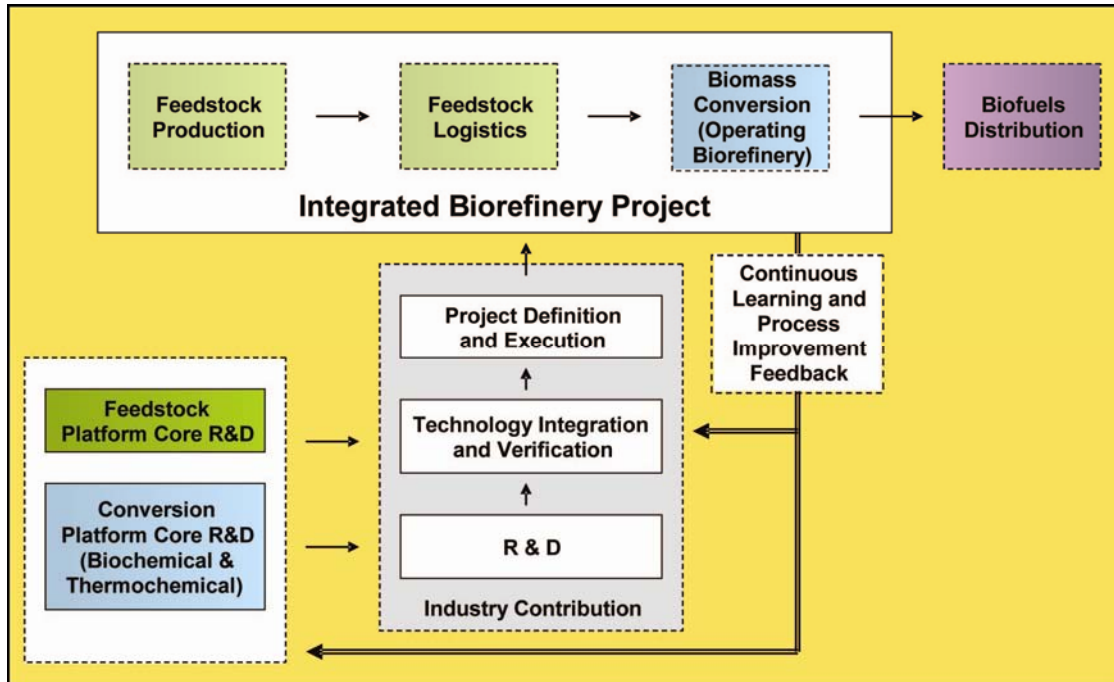

Figure 3-21: Integrated Biorefineries Project Scope, Major Stages and Connection to Core R&D Efforts

Integrated Biorefinery Stages of Development

The stages described here briefly outline the various factors involved in biorefinery development. It is important to note that intellectual property rights, geographic considerations, and market factors will determine the feedstock and conversion technology options that industry will ultimately choose to demonstrate and commercialize.

Technology integration and validation verifies the performance of the given suite of technologies from both a technical and an economic perspective. Technology validation is essential to the identification of design flaws that must be corrected for a successful commercial launch. If these potential problems are not corrected or remain unidentified, it is unlikely that a plant will achieve its design capacity and profitability. The integration of various technologies with each other in the pilot stages of biorefinery development will strengthen projects in their later demonstration stages, encouraging investment. Included in this analysis are both the laboratory data developed for specific processing steps and data from integrated biorefinery runs with partners at validation and commercial scale.

Project definition includes developing a detailed facility design coupled with mass and energy balances that identify technical uncertainties or issues that have not been resolved. In these cases, additional R&D and piloting may be required before the project can continue. Facility permitting is a long iterative process and should be initiated during this stage.

Project execution includes facility construction, pre-commissioning, commissioning and performance acceptance testing. Some design flaws may not be identified until startup, and could result in a wide range of training, equipment, or design issues. The duration of construction is expected to last one to three years. Commissioning should take anywhere from months to years. Obviously, the more detailed and complete the preparation, the easier and shorter the commissioning process. Often, failure to get through the commissioning and subsequent performance acceptance tests in a timely fashion will result in project failure, referred to as the “valley of death.” The identification and resolution of the process issues is an ongoing process.

Commercial operation will require resolving any processing problems discovered during commissioning, performance testing and early operations. The energy and chemical process industries have often shown that performance problems are much more likely for advanced systems than for systems with prior commercial experience. The learning that stems from commercial-scale operation and cumulative production will lead to continuous improvement that is expected to significantly enhance the technical and economic success of future biorefineries. This learning curve eludes to the “nth plant” concept where the learning curve has been lowered to the point that the technology and technological risks are relatively well known and predictable. At this point, risk and return calculations are relegated to typical supply/demand economics.

Integrated Biorefinery Interfaces with Core R&D

The core R&D is focused on developing the scientific and engineering underpinnings of a bioindustry by understanding technical barriers and providing engineering solutions. As projects identify new issues that require in-depth investigation, the public/private partnerships created offer a unique advantage of allowing additional resources to identify and resolve the underlying

technical problems.

Feedstock Platform Core R&D

A biorefinery must operate with predictable efficiency; therefore, plant operations are dependent on a continuous, replicable feedstock stream to achieve their market targets. Feedstock availability, variability, quality control storage, and processing costs are all major issues that will affect the economics of the plant.

Biochemical Conversion Core R&D

The development of advanced biochemical conversion technology must be accomplished to achieve the full potential of the integrated biorefinery. Through the implementation of the necessary technological advances, cellulosic feedstock conversion processes have the potential to achieve similar investment returns as conventional grain-based processes. Better yet, in the near term, the integration of conventional biofuels production with cellulosic conversion technology will likely have a synergistic effect and lower the entry cost of cellulose and increase the bottom line of the conventional process.

Thermochemical Conversion Core R&D

To achieve the full potential of the integrated biorefinery, the development of thermochemical conversions technologies must be accomplished to maximize the biofuel yield and feedstock flexibility. The achievement of advances in various biorefinery technologies will mean that a more diverse feedstock supply can be utilized, providing flexibility to achieve each plant's performance economics.

Although thermochemical and biochemical conversions are referred to as separate topics, the vast majority of biorefineries will employ both of these conversion platforms to optimize their effectiveness and efficiency.

3.3.1 INTEGRATED BIOREFINERIES PLATFORM SUPPORT OF PROGRAM STRATEGIC GOALS

Integrated Biorefineries platform is essential to achieving the Biomass Program's overarching strategic goal which is to develop sustainable, cost-competitive biomass technologies to enable the production of biofuels nationwide and reduce gasoline use 20 percent by 2017, thus supporting President's "20 in 10" goal.

The Integrated Biorefineries platform's strategic goal is to *demonstrate and validate integrated technologies to achieve commercially acceptable performance and cost pro forma targets*. This goal can only be accomplished through public-private partnerships.

The Biorefineries platform directly addresses and supports all pathways.

3.3.2 INTEGRATED BIOREFINERIES PLATFORM SUPPORT OF PROGRAM PERFORMANCE GOALS

The 2012 performance goal of the Integrated Biorefineries platform is to demonstrate the

successful operation of three integrated biorefineries across various pathways. By 2017, mature⁶ technology plant model⁷ will be validated for cost of ethanol production based on pioneer plant performance and compared to the target of \$1.33/gallon.

The performance goals for the pathways currently under investigation are as follows:

Corn Dry Mill Improvements Pathway

- Demonstrate and validate economical corn fiber-to-ethanol in a corn dry grind mill by 2012.

Agricultural Residue Processing Pathway

- Demonstrate and validate integrated agricultural residues-to-ethanol process at demonstration or commercial scale by 2012.
- Demonstrate and validate production of ethanol from mixed alcohols produced from agricultural residues (lignin- or biomass-derived) syngas at demonstration or commercial scale by 2012.

3.3.3 INTEGRATED BIOREFINERIES CHALLENGES AND BARRIERS

Market Challenges and Barriers

Im-A. Inadequate Supply Chain Infrastructure: The uncertainty of a sustainable supply chain and the associated risk are major barriers to procuring capital for start-up biorefineries. The lack of operating biorefineries to create the demand for biomass exacerbates the problem. Once demand is established, the infrastructure will grow. Producing and delivering bioenergy products in large volumes will require dramatic capital investments throughout the supply chain—from feedstock production and transport through conversion processing and product delivery.

Im-B. Agricultural Sector-Wide Paradigm Shift: Energy production from biomass on a large scale will require careful evaluation of U.S. agricultural resources and logistics, as these will likely require a series of major system changes that will take time to implement. Current harvesting, storage, and transportation systems are inadequate for processing and distributing biomass on the scale needed to support dramatically larger volumes of biofuels production.

Im-C. Lack of understanding of environmental/ energy tradeoffs: A systematic evaluation of the impact on the environment and food supply for humans and animals of expanded biofuels

⁶ The ethanol production cost targets are estimated mature technology processing costs which means that the capital and operating costs are assumed to be for an “nth plant” where several plants have been built and are operating successfully so that additional costs for risk financing, longer startups, under performance, and other costs associated with pioneer plants are not included.

⁷ The modeled cost refers to the use of models to project the cost such as those defined in the NREL design reports:

- 1) “Lignocellulosic Biomass to Ethanol Process Design and Economics Utilizing Co-Current Dilute Acid Prehydrolysis and Enzymatic Hydrolysis for Corn Stover,” NREL TP-510-32438, June 2002.
- 2) “Thermochemical Ethanol via Indirect Gasification and Mixed Alcohol Synthesis of Lignocellulosic Biomass,” NREL/TP-510-41168, April 2007.
- 3) Feedstock Logistics Design Report, final editing in progress as of 09/27/07.

production and use is lacking. Analytical tools to facilitate consistent evaluation of energy benefits and greenhouse gas emission impacts of all potential biofuels feedstock and production processes is needed.

Im-D. High Risk of Large Capital Investments: Once emerging biomass technologies have been developed and tested, they must be commercially deployed. Financial barriers are the most challenging aspect of technology deployment. Capital costs for commercially viable facilities are relatively high, and securing capital for unproven technology can be extremely difficult. For private investors to confidently finance biomass technology, the technology must be fully demonstrated as technically and commercially competent. Government assistance at the demonstration stage to accelerate proof of performance is critical to successful deployment.

Im-E. Lack of Industry Standards and Regulations: The lack of local, state, and federal regulations and inconsistency among existing regulations constrain development of biomass industry. The long lead times associated with developing and understanding new and revised regulations for technology can delay or stifle commercialization and deployment. Consistent standards are lacking for feedstock supply and infrastructure, as well as for biofuels and the associated distribution infrastructure.

Im-F. Cost of Production: An overarching market barrier for biomass technologies is the inability to compete, in most applications, with fossil energy supplies and their established supporting facilities and infrastructure. Uncertainties in fossil energy price and supply continue to exert upward pressure on the price of petroleum-derived fuels and products. Nevertheless, reductions in production costs along the biomass supply chain are needed to make bio-based fuels and products competitive in these markets.

Technical (Non-Market) Challenges/Barriers

It-A. End-to-End Process Integration: Successful advances in biochemical and thermochemical processes and the biorefinery concept are co-dependent. This biorefinery concept encompasses a wide range of technical issues related to collecting, storing, transporting, and processing diverse feedstocks, as well as the complexity of integrating several innovative process steps, thus entailing considerable technical risk. The challenge of feed-to-product process integration is crucial, as it impacts both performance and profitability.

It-B. Commercial-Scale Demonstration Facilities: As with all new process technologies, demonstrating sustained integrated performance that meets technical, environmental and safety requirements at sufficiently large scale is an essential step toward commercialization. Demonstration facilities that are capable of testing and validating new technologies and integrated systems are critical to successful commercial deployment. Additionally, increased understanding of these combined systems will result in the optimization of process configurations. Integrating new bioenergy processes with existing biorefineries, while improving the efficiency of all biorefineries, are two critical areas of focus for the platform.

It-C. Risk of Pioneer Technology: The first biorefineries will incorporate a variety of new technologies. The number of new process steps implemented in a demonstration project has been shown to be a strong predictor of future performance shortfalls. Heat and mass balances, and

their implications, are not likely to be well understood in regard to new technologies. In addition, the impact of unanticipated buildup of impurities in process streams that can result in abrasion and corrosion of plant equipment and deactivation of process catalysts is not well understood.

It-D. Sensors and Controls: Effective process control will be needed to maintain plant performance and emissions at target levels because of variability in processing conditions, load, feedstock and intermediate stream properties. Development of new sensors and analytical instruments is needed to optimize control systems for biochemical and thermochemical systems. There are several key technical barriers to consider, including the lack of real-time sensors for measuring feedstock moisture and composition, the need for better tools to analyze various process streams, and the lack of process control systems for reactor systems and subsystems.

It-E. Engineering Modeling Tools: The current level of understanding regarding fuels chemistry is insufficient for optimization, scale-up, and commercialization. In order to better understand how fuel chemistry affects commercial viability, rigorous engineering computational fluid dynamic models are needed. Engineering modeling tools are also needed to address heat integration issues.

3.3.4 INTEGRATED BIOREFINERIES PLATFORM APPROACH FOR OVERCOMING CHALLENGES AND BARRIERS

The Program's efforts to overcome the challenges and barriers associated with the Integrated Biorefineries platform are organized around the seven pathways (see Appendix C for description of the Program's strategy of biorefinery pathway framework), as illustrated in Figure 3-22. The WBS under each pathway is comprised of three major elements:

1. Demonstration and deployment includes all the major integrated biorefinery projects, collectively representing the largest portion of the overall platform budget.
2. Technical assistance covers smaller R&D projects that are identified by industry partners and stakeholders as critical to improving existing biorefinery operations.
3. Analysis covers a broad range of technical, economic and environmental topics, and is used to assess the individual progress of the integrated biorefinery projects as well as the collective status and progress of the bioindustry.

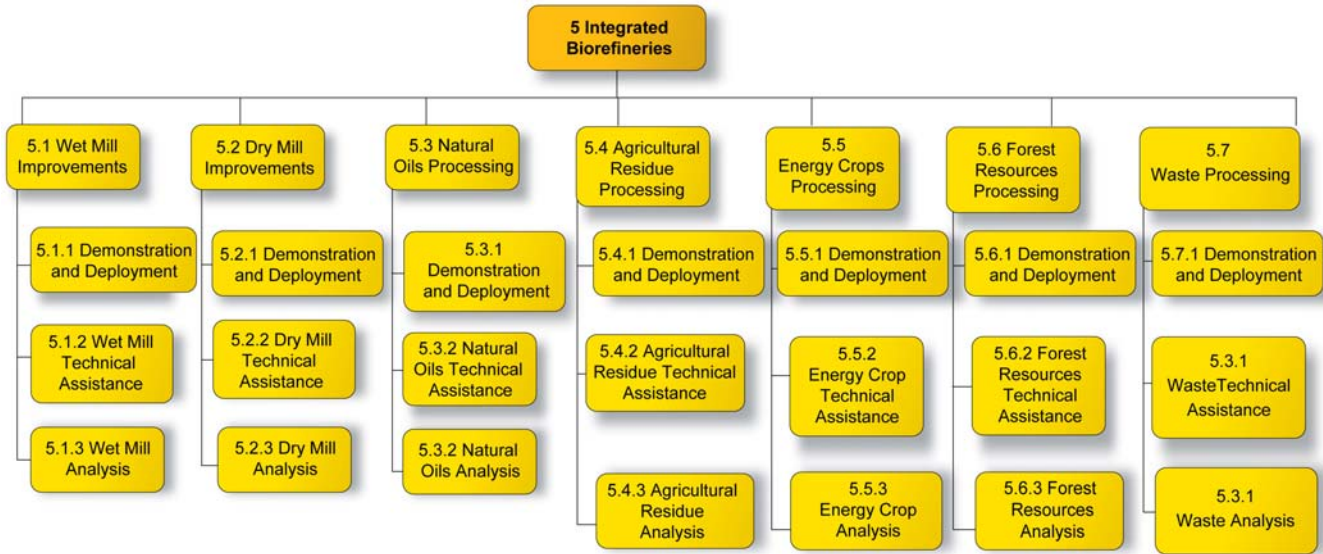

Figure 3-22: Integrated Biorefineries Work Breakdown Structure

WBS 5.1 and 5.2 Corn Wet Mill and Corn Dry Mill Improvements Pathways

The objective for both corn mill pathways is to improve the overall operation of today’s production facilities by incorporating new technologies into the existing corn milling processes to increase yields of biofuels. The utilization of these fibrous materials has the ancillary benefit of improving the quality and salability of the protein co-products minimizing problems associated with the rapid growth of the biofuels industry. Other near-term opportunities for wet mill and dry mill improvements include production of new bioproducts, improvements in plant efficiency and reductions in operating costs.

In FY 2002, a solicitation for public-private partnerships to develop integrated biorefinery technologies resulted in six major projects associated with corn wet and dry grind mills. These projects began to address key programmatic barriers, such as end-to-end process integration, the risk of pioneer technology, and the lack of engineering modeling tools.

WBS 5.3 Natural Oils Processing Improvements Pathway

The objective of this pathway is to increase production of biofuels through the introduction of new, low-cost oils feedstock. Renewable diesel products are the primary biofuels of this pathway. The use of existing waste fats and greases is seen as a near-term strategy, while the development of advanced high oil-content seed crops is seen as a longer-term goal. Other opportunities for oil seed processing mill improvements include production of new bioproducts from the refined oil and glycerol byproduct streams.

WBS 5.4 Agricultural Residue Processing Pathway

The objective for this pathway is to develop and demonstrate new commercially viable processes and systems to convert residues from current agricultural production activities to biofuels. Both biochemical and thermochemical conversion technologies, individually or in combination, are under evaluation. Using existing agricultural residues is seen as the primary strategy to bridge the gap between near-term, niche, low-cost biomass supplies and long-term high-volume dedicated energy crops. Other potential product options include hydrogen; organic chemicals and

petrochemical replacements; and electricity.

Several industry leaders have partnered for development of technological advancements, with projected processing of 700 tons per day of corn stover, wheat straw, barley straw, rice straw and milo stubble to produce both ethanol and power.

WBS 5.5 Energy Crops Processing Pathway

The objective for this pathway is to develop and demonstrate new commercially viable processes and systems to convert dedicated energy crops to biofuels, which is the foundation of the long-term strategy for petroleum displacement. Conversion technologies and processes for dedicated perennial feedstocks will build on the experience gained through processing agricultural and forest residues and process intermediates in commercial-scale facilities. Both biochemical and thermochemical conversion technologies are under evaluation.

WBS 5.6 Forest Resources Processing Pathway

The Forest Resources Processing pathway is a consolidation of the Pulp and Paper Mill Improvements and the Forest Products Mill Improvements pathways described in the previous version of the MYPP, with the added scope of logging and fuel treatment residues as well as unutilized conventional wood. The objectives of this pathway include the development and demonstration of the conversion of forest resources to biofuel, as well as an improvement in the economic efficiency of existing pulp and paper mills. One consideration may be the conversion of underperforming existing pulp and paper mills into plants that produce biofuels.

WBS 5.7 Waste Processing Pathway

This is a new pathway was added to the Program portfolio based on the quantity and availability of cellulosic wastes for biofuels production. The objective is to develop and demonstrate new commercially viable processes to convert the cellulosic fractions of various waste streams to biofuels. Feedstocks include municipal solid waste, urban wood waste, and construction and demolition wastes.

The approaches for overcoming the barriers within each pathway, along with specific tasks/activities, are described in Table 3-7. Integration is the key component for successful development and deployment of a biorefinery. Thus the vast majority of the Program's biorefinery industrial partnerships, along with being associated with a principal pathway, also crosscuts secondary and in some cases, even tertiary pathways.

Table 3-7: Integrated Biorefinery Task Summary

Platform Goal: Develop cost-competitive biomass technologies to enable the production of biofuels nationwide and reduce dependence on oil through domestic bioindustry		
WBS Element	Description	Barriers Addressed
5.1 Corn Wet Mill Improvement Pathway		
5.1.1 Demonstration and Deployment	From 2002-2006, the Program supported projects that focused on technology development with near-term commercial potential and provided the opportunity to lay the groundwork for future lignocellulosic biomass technologies. 2007-2012 Future D&D projects in this area would need to have broad applicability to a variety of biomass feedstocks that represent a significant increased market potential for biofuels production.	It-A: End-to-End Process Integration It-B: Commercial-Scale Demonstration Facilities It-C: Risk of Pioneer Technology
5.1.2 Technical Support	Research into near-term technical improvements that can be implemented within the existing industry infrastructure and are a priority of the industry. 2007-2012 <ul style="list-style-type: none"> ▪ Residual starch conversion ▪ Corn fiber hydrolysis and mixed sugar fermentation ▪ Corn oil extraction 2013-2017 <ul style="list-style-type: none"> ▪ New products from sugars 	It-C: Risk of Pioneer Technology It-E: Engineering Modeling Tools
5.1.3 Analysis	Growth of the existing corn wet mill industry is not expected to contribute significantly to meeting the “20 in 10” goal. Therefore, analysis activities to track industry progress and its associated benefits will be limited.	Im-C: Lack of understanding of environmental/ energy tradeoffs It-E: Engineering Modeling Tools
5.2 Corn Dry Mill Improvement Pathway		
5.2.1 Demonstration and Deployment	From 2002-2006, the Program supported projects that focused on technology development with near-term commercial potential and provide the opportunity to lay the groundwork for future lignocellulosic biomass technologies. 2007-2012 <ul style="list-style-type: none"> ▪ Pioneer Plant Projects <ul style="list-style-type: none"> ○ Demonstrate the benefits of integrating cellulosic ethanol conversion technology into an existing corn dry grind infrastructure. ▪ 10% Demonstration Scale Projects 2013-2017 <ul style="list-style-type: none"> ▪ TBD based on progress and stakeholder input 	It-A: End-to-End Process Integration It-B: Commercial-Scale Demonstration Facilities It-C: Risk of Pioneer Technology
5.2.2 Technical Support	Research into near-term technical improvements that can be implemented within the existing industry infrastructure and are a priority of the industry. 2007-2012 <ul style="list-style-type: none"> ▪ Residual starch conversion ▪ corn fiber hydrolysis and mixed sugar fermentation ▪ Corn oil extraction ▪ New fractionation processes 2013-2017 <ul style="list-style-type: none"> ▪ New products from sugars ▪ New products from proteins 	It-C: Risk of Pioneer Technology It-E: Engineering Modeling Tools
5.2.3 Analysis	Growth of the existing corn dry grind industry is expected to contribute significantly to meeting the “20 in 10” goal. Analysis	Im-C: Lack of understanding of

	<p>activities to track industry progress and its associated benefits include:</p> <p>2007-2012</p> <ul style="list-style-type: none"> ▪ Corn dry grind industry growth scenarios ▪ Economic and life cycle assessment of existing, and potential new technologies, including sustainability and potential policy implications <p>2013-2017</p> <ul style="list-style-type: none"> ▪ Continued analysis and validation of industry growth, economic and life cycle assessment, including sustainability and policy implications 	<p>environmental/ energy tradeoffs</p> <p>It-E: Engineering Modeling Tools</p>
5.3 Natural Oils Processing Improvements		
5.3.1 Demonstration and Deployment	<p>2007-2012</p> <p>Future D&D projects in this area would need to have broad applicability to a variety of biomass feedstocks that represent a significant increased market potential for biofuels production.</p>	<p>It-A: End-to-End Process Integration</p> <p>It-B: Commercial-Scale Demonstration Facilities</p> <p>It-C: Risk of Pioneer Technology</p>
5.3.2 Technical Support	<p>Research into near-term technical improvements that can be implemented within the existing industry infrastructure and are a priority of the industry.</p> <p>2007-2012</p> <ul style="list-style-type: none"> ▪ Soybean meal hydrolysis ▪ Products from glycerol (biodiesel byproduct) <p>2013-2017</p> <ul style="list-style-type: none"> ▪ New products from proteins 	<p>It-C: Risk of Pioneer Technology</p> <p>It-E: Engineering Modeling Tools</p>
5.3.3 Analysis	<p>Growth of the existing oils processing industry is expected to contribute significantly to meeting the “20 in 10” goal. Analysis activities to track industry progress and its associated benefits include:</p> <p>2007-2012</p> <ul style="list-style-type: none"> ▪ Oils processing industry growth scenarios ▪ Economic and life cycle assessment of existing, and potential new technologies including sustainability and potential policy implications <p>2013-2017</p> <ul style="list-style-type: none"> ▪ Continued analysis and validation of industry growth, economic and life cycle assessment, including sustainability and policy implications 	<p>Im-C: Lack of understanding of environmental/ energy tradeoffs</p> <p>It-E: Engineering Modeling Tools</p>
5.4 Agricultural Residue Processing		
5.4.1 Demonstration and Deployment	<p>Development, demonstration, and commercial-scale validation of agricultural residue processing for biofuels production are critical steps needed if lignocellulosic biomass is expected to contribute to meeting the “20 in 10” goal. Major efforts include:</p> <p>2007-2012</p> <ul style="list-style-type: none"> ▪ Pioneer Plant Projects ▪ 10% Demonstration Scale Projects <p>2013-2017</p> <ul style="list-style-type: none"> ▪ TBD based on progress and stakeholder input 	<p>It-A: End-to-End Process Integration</p> <p>It-B: Commercial-Scale Demonstration Facilities</p> <p>It-C: Risk of Pioneer Technology</p>
5.4.2 Technical Support	<p>As the pioneer and demonstration plant projects progress, common technical issues may emerge that could become the subject of targeted research efforts to support the emerging residue processing industry.</p> <p>2007-2012</p> <ul style="list-style-type: none"> ▪ Leverage developments from the core R&D areas including feedstock and conversion ▪ TBD based on stakeholder input <p>2013-2017</p> <ul style="list-style-type: none"> ▪ Continue to leverage developments from the core R&D areas including feedstock and conversion ▪ TBD based on stakeholder input 	<p>It-C: Risk of Pioneer Technology</p> <p>It-E: Engineering Modeling Tools</p>

5.4.3 Analysis	<p>Analysis activities to track industry progress and its associated benefits include:</p> <p>2007-2012</p> <ul style="list-style-type: none"> ▪ Agricultural residue production and processing industry growth scenarios ▪ Economic and life cycle assessment of existing, and potential new technologies, including sustainability and potential policy implications <p>2013-2017</p> <ul style="list-style-type: none"> ▪ Continued analysis and validation of industry growth, economic and life cycle assessment, including sustainability and policy implications 	<p>Im-C: Lack of understanding of environmental/ energy tradeoffs</p> <p>It-E: Engineering Modeling Tools</p>
5.5 Energy Crops Processing		
5.5.1 Demonstration and Deployment	<p>Development, demonstration, and commercial-scale validation of agricultural residue processing for biofuels production are critical steps needed if lignocellulosic biomass is expected to contribute to meeting the “20 in 10” goal. Major efforts include:</p> <p>2007-2012</p> <ul style="list-style-type: none"> ▪ Pioneer plant ▪ 10% Demonstration-scale projects <p>2013-2017</p> <ul style="list-style-type: none"> ▪ TBD based on progress and stakeholder input 	<p>It-A: End-to-End Process Integration</p> <p>It-B: Commercial-Scale Demonstration Facilities</p> <p>It-C: Risk of Pioneer Technology</p>
5.5.2 Technical Support	<p>As the pioneer and demonstration plant projects progress, common technical issues may emerge that could become the subject of targeted research efforts to support the emerging energy crop processing industry.</p> <p>2007-2012</p> <ul style="list-style-type: none"> ▪ Leverage developments from the core R&D areas including feedstock and conversion ▪ TBD based on progress and stakeholder input <p>2013-2017</p> <ul style="list-style-type: none"> ▪ Continue to leverage developments from the core R&D areas including feedstock and conversion ▪ TBD based on progress and stakeholder input 	<p>It-C: Risk of Pioneer Technology</p> <p>It-E: Engineering Modeling Tools</p>
5.5.3 Analysis	<p>Energy crop production and processing industry growth scenarios</p> <p>Economic and life cycle assessment of existing, and potential new technologies including sustainability and potential policy implications</p> <p>2013-2017</p> <ul style="list-style-type: none"> ▪ Continued analysis and validation of industry growth, economic and life cycle assessment, including sustainability and policy implications 	<p>Im-C: Lack of understanding of environmental/ energy tradeoffs</p> <p>It-E: Engineering Modeling Tools</p>
5.6 Forest Resources Processing:		
5.6.1 Demonstration and Deployment	<p>From 1990s-2006, the Program supported D&D projects that focused on black liquor gasification with the potential for near-term commercialization of a more energy-efficient processing route. Current activities are focused on fractionation and recovery of fiber streams as well as integrating both thermochemical and biochemical technologies for the conversion of forest product residues to biofuels.</p> <p>2007-2012</p> <ul style="list-style-type: none"> ▪ Pioneer plant ▪ 10% Demonstration-scale projects <p>2013-2017</p> <ul style="list-style-type: none"> ▪ TBD based on progress and stakeholder input 	<p>It-A: End-to-End Process Integration</p> <p>It-B: Commercial-Scale Demonstration Facilities</p> <p>It-C: Risk of Pioneer Technology</p>
5.6.2 Technical Support	<p>Research into near-term technical improvements that can be implemented within the existing industry infrastructure and are a priority of the industry.</p> <p>2007-2012</p> <ul style="list-style-type: none"> ▪ Extraction of hemicellulosic sugars prior to pulping followed by fermentation to ethanol ▪ Leverage developments from the core R&D areas including feedstock and conversion <p>2013-2017</p>	<p>It-C: Risk of Pioneer Technology</p> <p>It-E: Engineering Modeling Tools</p>

	<ul style="list-style-type: none"> ▪ TBD based on progress and stakeholder input ▪ Continue to leverage developments from the core R&D areas including feedstock and conversion 	
5.6.3 Analysis	<p>2007-2012</p> <ul style="list-style-type: none"> ▪ Forest residue utilization scenarios ▪ Pulp and paper industry growth scenarios ▪ Forest products industry growth scenarios ▪ Economic and life cycle assessment of existing, and potential new technologies including sustainability and, potential policy implications <p>2013-2017</p> <ul style="list-style-type: none"> ▪ Continued analysis and validation of industry growth, economic and life cycle assessment, including sustainability and policy implications 	<p>Im-C: Lack of understanding of environmental/ energy tradeoffs</p> <p>It-E: Engineering Modeling Tools</p>
5.7 Waste Processing		
5.6.1 Demonstration and Deployment	<p>The Program has supported RD&D projects focused on Sorted MSW conversion to liquid biofuels in the past (Amoco and Masada). This feedstock type is being reconsidered based on the potential magnitude and ready availability of the resource.</p> <p>2007-2012</p> <ul style="list-style-type: none"> ▪ Pioneer Plant ▪ 10% Demonstration Scale Projects <p>2013-2017</p> <p>TBD based on progress and stakeholder input</p>	<p>It-A: End-to-End Process Integration</p> <p>It-B: Commercial-Scale Demonstration Facilities</p> <p>It-C: Risk of Pioneer Technology</p>
5.6.2 Technical Support	<p>Research into near-term technical improvements that can be implemented within the existing industry infrastructure and are a priority of the industry.</p> <p>2007-2012</p> <ul style="list-style-type: none"> ▪ Leverage developments from the core R&D areas, including feedstock and conversion ▪ TBD based on progress and stakeholder input <p>2013-2017</p> <ul style="list-style-type: none"> ▪ Continue to leverage developments from the core R&D areas, including feedstock and conversion ▪ TBD based on progress and stakeholder input 	<p>It-C: Risk of Pioneer Technology</p> <p>It-E: Engineering Modeling Tools</p>
5.6.3 Analysis	<p>2007-2012</p> <ul style="list-style-type: none"> ▪ Waste processing industry growth scenarios ▪ Economic and life cycle assessment of existing, and potential new technologies, including sustainability and, potential policy implications <p>2013-2017</p> <ul style="list-style-type: none"> ▪ Continued analysis and validation of industry growth, economic and life cycle assessment, including sustainability and policy implications 	<p>Im-C: Lack of understanding of environmental/ energy tradeoffs</p> <p>It-E: Engineering Modeling Tools</p>

3.3.5 *PRIORITIZING INTEGRATED BIOREFINERY PLATFORM BARRIERS*

The Biomass Program is developing a suite of technologies across the biorefinery pathways to enable a broad spectrum of biomass resources to be used in the production of a variety of biofuels.

3.3.6 *INTEGRATED BIOREFINERY PLATFORM MILESTONES AND DECISION POINTS*

The key Integrated Biorefinery platform milestones, inputs/outputs and decision points to complete the tasks described in section 3.3.4 are summarized in the chart in Figure 3-23.

The highest-level milestones serve as the performance goals (listed in section 3.3.2) for the Integrated Biorefineries platform. These performance goals represent the first steps to commercialization for specific routes through the priority pathways. Because of the cost and technology maturity for the demonstration- and commercial-scale efforts, this work is conducted via competitively awarded cost-share agreements with industry. The targets/milestones listed in Table 2-1 outline the successful operation of the full-scale system and validate that it meets the set of performance metrics defined for each specific design. Underlying these high-level targets are milestones tracking the progression from contract award, to construction, start-up and operation of each demonstration or commercial scale biorefinery.

The following definitions apply to the programmatic milestones listed in Figure 3-23.

- **Downselect:** Based on bench scale evaluation of viable processes/technologies, select the process design configuration that will move forward for demonstration in an integrated pilot plant.
- **Demonstrate:** At pilot scale and beyond, verify that the unit operations operate as designed and meet the complete set of performance metrics (individually and as an integrated system).
- **Validate:** At pilot scale and beyond, ensure the process/system meets desired expectations/original intent. Validation goes beyond just meeting all of the performance metrics; it is an assessment of whether the system actually fulfills/completes a portion of the program effort so that the Program can move on to the next priority.

Figure 3-23: Integrated Biorefineries Gantt Chart

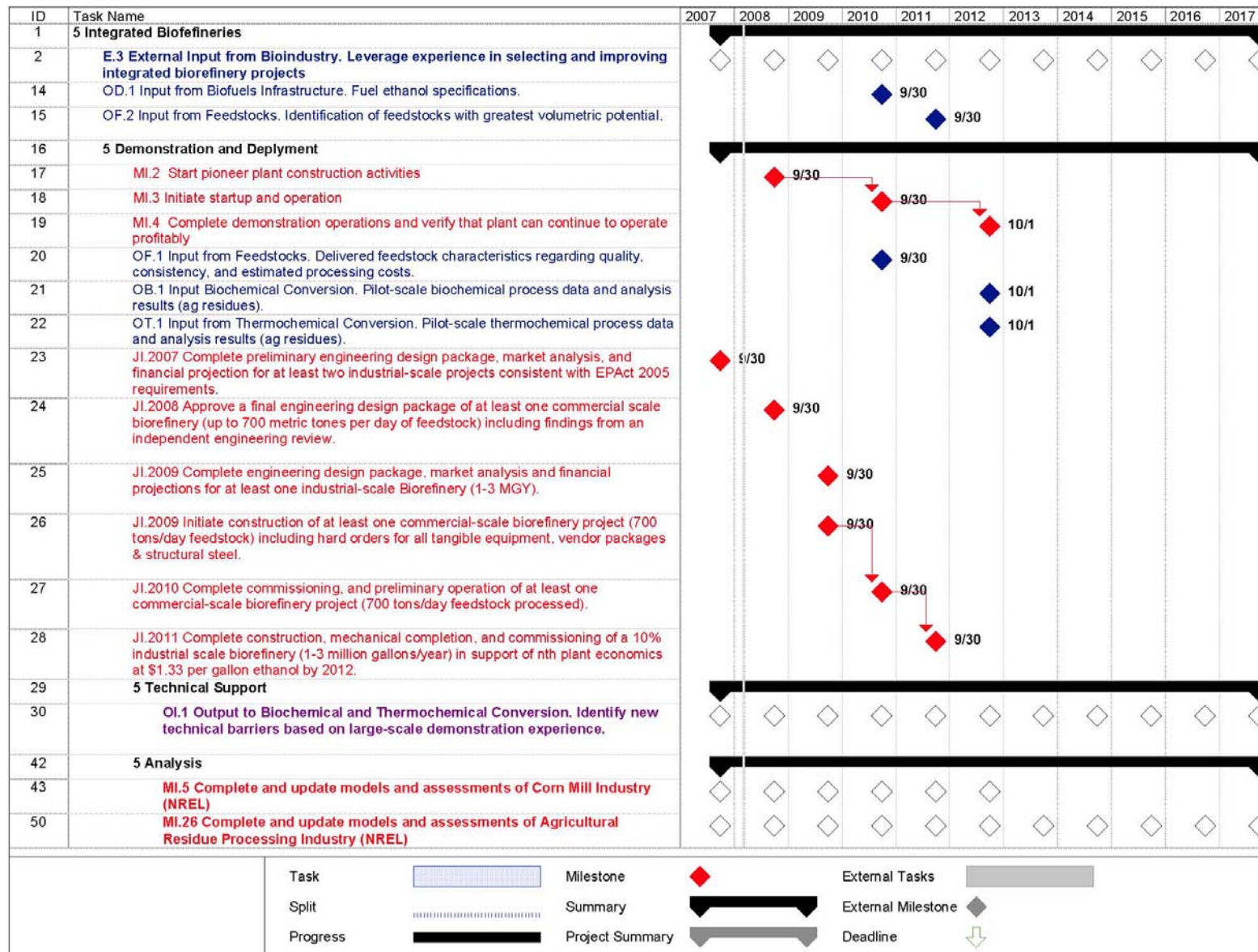

ID	Task Name	2007	2008	2009	2010	2011	2012	2013	2014	2015	2016	2017
62	JI.2011 Validate economics, system performance, of at least one one commercial-scale biorefinery project (700 tons/day feedstock processed) in support of nth plant economics at \$1.33 per gallon of ethanol by 2012.						◆ 9/30					
63	JI.2012 Using commercial scale biorefinery and 10% industrial scale biorefinery performance validate nth plant economics at the \$1.33/gal ethanol.							◆ 10/1				

3.4 BIOFUELS INFRASTRUCTURE AND END USE

In order to achieve large-scale market adoption of biofuels, significant infrastructure challenges, including distribution, storage, materials compatibility, fuel dispensing and vehicle end use, must be addressed (Figure 3-24). In part, infrastructure needs will depend on the way in which ethanol is integrated into the fuel mix.

To date, the U.S. has pursued a dual approach for integrating ethanol into the nation’s transportation energy sector – through the use of low-level and high-level ethanol blends. The majority of ethanol sold in the nation today is marketed as a blend of up to 10 volume percent ethanol with gasoline, commonly referred to as E10. E85, which denotes up to 85 percent ethanol content, is primarily used in the Midwest where much of the ethanol is produced. Less than 1 percent of the almost 8 billion gallons of ethanol produced annually is used to make E85.

Given the fact that the E85 market has been very slow to develop, DOE, in close collaboration with EPA and DOT, is evaluating the performance, materials, emissions and health and safety impacts of increasing the allowable minimum blend beyond E10 to E15, E20, or higher. The Biomass Program’s infrastructure work in the near term will focus largely on this evaluation. If intermediate blends prove to be acceptable based on a variety of different environmental, performance, and other criteria, and are approved by EPA, these intermediate blends could be used nationwide in all types of vehicles, thereby reducing the need for substantial increases in E85 fueling stations and flexible-fuel vehicles (FFVs) which can operate on E-85. Other infrastructure challenges such as transport and storage will remain.

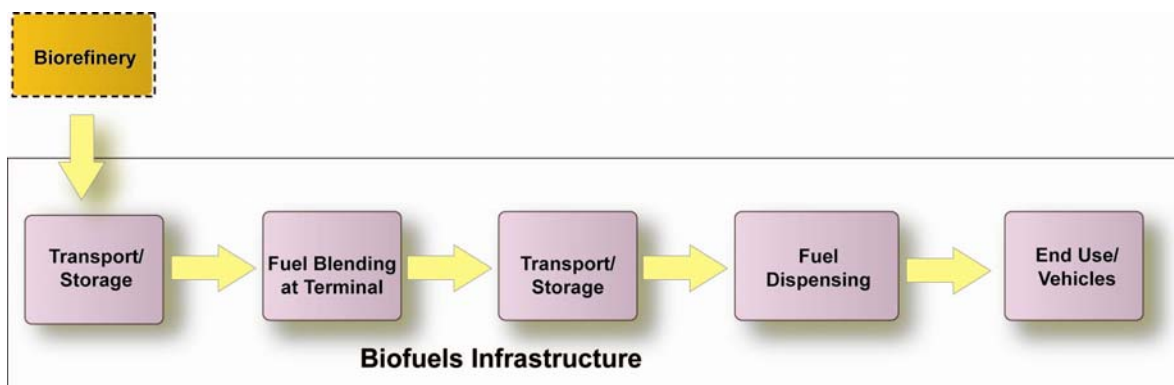

Figure 3-24: Infrastructure Platform Flow Chart

Transport/Storage and Fuel Blending develops the storage, transport and blending technology needed to ship, store and blend significant volumes of ethanol. Rail, trucking, and barges will continue to be used in the transport of ethanol at least in the near term.

Ethanol is delivered from biorefineries to gasoline by truck, then blended with gasoline at the terminal racks and finally distributed to individual fueling stations by truck. While this process is reasonably economical in the Midwest, trucking is not an attractive option for delivery outside of the Midwest, particularly as volumes increase.

Rail transportation of ethanol offers a lower bulk transportation cost option, serves the

continental U.S., and will likely remain the mainstay of our ethanol transportation infrastructure for the foreseeable future. In 2017, projected ethanol volumes will impose only 2 to 3 percent additional capacity on the rail industry. On a national level, the rail system has sufficient spare capacity to handle the additional ethanol volume; however, regional bottlenecks remain an issue to the deployment of large volumes of ethanol to all parts of the country. Ethanol is also transported by barge; however, only a limited number of ethanol production and blending facilities have river access and can be served by this option.

Pipelines, already used in Brazil to transport ethanol, are likely to play a significant role in future distribution of ethanol in the U.S. The primary inhibitors to transporting ethanol and other biofuels through existing pipelines are material compatibility and flow direction. Ethanol is more corrosive, attacking metal components and extracting contaminants that downgrade the value of the ethanol and could potentially reach car engines. Ethanol also absorbs water which can result in the separation of petroleum hydrocarbons and the ethanol. DOT and the hazardous liquid pipeline industry are working together to remove all technical and regulatory biofuel barriers for pipelines. This enterprise approach is leveraging efforts while integrating Brazilian experience. Market forces will ultimately determine pipeline usage in transporting biofuels once these barriers are removed.

As additional ethanol plants come online outside the Midwest, some of the long distance transport needs will be reduced. However, large amounts of ethanol will continue to be produced in the Midwest where feedstocks are readily available. Terminal blending and storage facilities will need to be developed regardless of the location of production.

The impacts of underground storage of ethanol, ethanol blended fuels, and other biofuels are not well understood. Without effective mitigation techniques, leaks from underground tanks could lead to water and soil quality degradation. Field studies have shown that the presence of ethanol may extend benzene plume length in underground water and may increase methane formation in soil gas above spills. This may make remediation of spills more challenging and more hazardous. In addition, the presence of ethanol may lead to greater dissolution of metals, such as arsenic, manganese, and lead in ground water.

Fuel Dispensing includes developing technology to dispense ethanol blended fuels into vehicles at fueling stations. Gasoline dispensers are not designed for storing and dispensing ethanol blends beyond E10. The interagency effort for testing intermediate blends will assess whether gasoline pumps can also dispense intermediate blends of ethanol without negative effects. In terms of E85, pumps designed and manufactured for dispensing E85 are available, but do not yet carry United Laboratories (UL) certification. DOE and EPA are working closely with UL to resolve this issue. While the certification on the dispensers is not expected to be a long-term obstacle, it does represent some of the complexities that will be encountered with regard to codes and standards as the nation increases its use of biofuels.

End Use Vehicles develops engine technologies to enable the use of E85 and intermediate blends of ethanol. Vehicle and small engines represent the consumer-owned portion of the biofuels infrastructure. Only FFVs can use E85, while all vehicles manufactured since 1978 can run on E10. Under the current vehicle warranty information, operation of non-FFVs on blends in

excess of E10 would void the manufacturers' warranties. The Biomass Program's evaluation of intermediate blends will consider the impact of these higher ethanol content fuels on legacy vehicles, including impact on performance, material, emissions, and health and safety.

3.4.1 BIOFUELS INFRASTRUCTURE SUPPORT OF PROGRAM STRATEGIC GOALS

The Biomass Program's overarching strategic goal is to develop sustainable, cost-competitive biomass technologies to enable the production of biofuels nationwide and reduce gasoline use 20 percent by 2017. The growth of the biofuels industry will develop incrementally over this period, and as it does, infrastructure must be in place to support the emerging biomass fuel and co-products industries. Absence of concomitant growth of the industry and infrastructure will increase the risk of local and regional market failure, and will potentially lead to supply-side bottlenecks, scarcity, and inefficient resource and product distribution.

The Biofuels Infrastructure platform's strategic goal is *to develop systematic approach to building a cost-effective infrastructure system that will be adaptable to changing needs to ensure widespread biofuel use for transportation*. The Infrastructure platform directly addresses and supports activities in partnership with other federal agencies, including but not limited to USDA, EPA, DOT, and DOC/NIST, as necessary to address infrastructure issues. The platform will develop and test transport, storage, fuel dispensers and vehicles; perform research and development to support the development of new codes and standards where necessary; and conduct analysis to promote the expanded use of biofuels in the nation's transportation sector.

3.4.2 BIOFUELS INFRASTRUCTURE SUPPORT OF PROGRAM PERFORMANCE GOALS

The Biofuels Infrastructure platform's performance goal is to complete standards development and testing of E15 and E20 distribution systems and vehicles, in partnership with EPA and DOT and develop capacity to transport and distribute 36 billion gallons of biofuels by 2022. The Infrastructure platform will test vehicles as part of the intermediate blend strategy and develop information on materials compatibility for various infrastructure components such as bulk storage systems, pumps, pipelines, and other key elements of the biofuels infrastructure. The platform will also address questions concerning the impact of intermediate blends on existing infrastructure and provide information on whether existing pipelines could be used for ethanol distribution. The platform's strategy for meeting these goals is described in section 3.4.4.

3.4.3 BIOFUELS DISTRIBUTION INFRASTRUCTURE CHALLENGES AND BARRIERS

Market Challenges and Barriers

Dm-A. Lack of Biofuels Distribution Infrastructure: While biofuels, as a liquid transportation fuel, has advantages over other alternative transportation fuels there still remains a lack of infrastructure to transport, store and dispense biofuels putting biofuels at a disadvantage compared to conventional liquid transportation fuels that already have mature infrastructure. Today's biofuels distribution infrastructure, which includes over 1,200 E85 fueling stations, is concentrated in the Midwest, near the feedstocks (corn and soybeans) and ethanol and biodiesel production facilities. To contribute significantly to the 20 in 10 volumetric goal, expansion

beyond this region of the country will be required.

Dm-B. Availability of Biofuels-Compatible Vehicles: About six million ethanol FFVs have been manufactured for the U.S. market, at a price competitive with conventional vehicles. However, at this time, only a limited number of vehicle model/fuel type combinations exist. In addition, most FFVs on the road today use less than 4 gallons of E85 per year due to the limited number of E85 pumps across the U.S.

Dm-C. Industry and Consumer Acceptance and Awareness: To be successful in the marketplace, biomass-derived products must perform at the same level or better than the existing fossil-energy-based products. Industry partners and consumers must believe in the quality, value and safety of biomass-derived products and their benefits.

Technical (Non-Market) Challenges/Barriers

Dt-A. Ethanol Pipeline Distribution Issues: Ethanol is a stronger solvent than the petroleum products moved via pipeline today. Consequently, ethanol will remove water, rust, gums and other contaminants from the existing petroleum pipeline distribution system. This downgrades the value of the delivered ethanol and adds back-end costs to restore the fuel to meet specifications. Construction of new dedicated ethanol pipelines are limited by the high cost of capital investment, insufficient ethanol supplies, materials compatibility issues, technologies that can measure quality in real time, and existing right-of-way agreements.

Dt-B. Limited Information Available for Developing Codes and Standards: National organizations that develop codes and standards recognize that additional data is required to integrate biofuels into the model codes for infrastructure construction. Thousands of local code jurisdictions in the U.S. adopt and modify these model codes for their use. At this time, insufficient technical information hinders revision of various codes and standards in support of the quickly accelerating biofuels industry. Lack of codes as well as costly project permitting processes can stymie the introduction of new technologies, including infrastructure, into the marketplace.

Dt-C. Materials Compatibility Issues of Alcohol Fuels: Alcohol fuels and alcohol fuel blends require components throughout the infrastructure system (e.g., fuel storage, pipes and piping, and on-board vehicle systems) that are compatible with the higher electrical conductivity and solubility of the fuel. Higher cost materials, including stainless steel, lined fiberglass tanks, and mild steel with epoxy coatings, are often required to ensure compatibility and mitigate risk of decay or failure.

Dt-D. Increased Evaporative Hydrocarbon Emissions of Ethanol Blends: Adding ethanol to gasoline increases the fuel volatility, as measured by its Reid vapor pressure (RVP). The higher RVP results in higher evaporative hydrocarbon emissions from ethanol blends than from straight gasoline. Ethanol in gasoline also increases the permeability of plastic on-board fuel tanks, which in turn contributes to increased evaporative emissions.

Dt-E. Ethanol Blend Vehicle Fuel Economy: Since ethanol has a lower heating value than gasoline (83,000 Btu/gal for E85 vs. 113,500 Btu/gal for gasoline), E85 delivers a lower fuel

economy when compared to gasoline on a gallon by gallon basis. Lower fuel economy can be counteracted by optimizing the engine design to take advantage of the higher octane rating of E85 (98 for E85 vs. 87 for gasoline).

3.4.4 BIOFUELS INFRASTRUCTURE APPROACH FOR OVERCOMING CHALLENGES AND BARRIERS

The work breakdown structure (WBS) below outlines the Biomass Program’s approach for overcoming biofuels infrastructure challenges. The Biofuels Infrastructure WBS focuses on ethanol at this point, but key technology development activities and information gathering protocols will consider the impact and relevancy of these activities to other biofuel commodities. Insight gained by considering ethanol and ethanol blends will serve as lessons learned for the future assessment of other biofuels commodities. Key tasks, as shown in Figure 3-25 are described in Table 3-8.

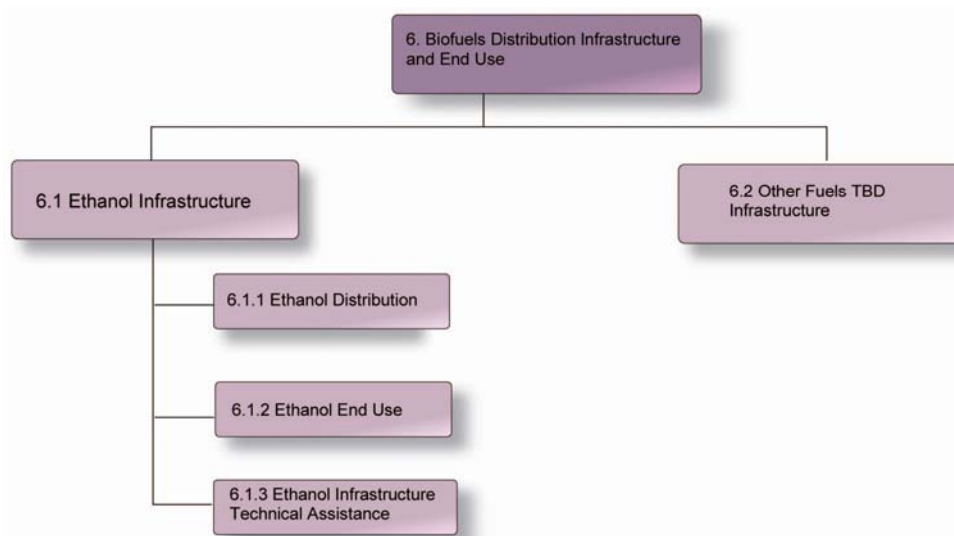

Figure 3-25: Work Breakdown Structure for Biofuels Infrastructure

Interagency collaboration and joint solicitations will be used to coordinate widespread development of biofuels infrastructure and ensure that U.S. policy is consistent and ensures stakeholder and public confidence. While the Biomass Program currently focuses on ethanol blended fuels, other biofuels such as, biodiesel, biobutenol, renewable gasoline, and other biofuels commodities will be considered. As part of these activities, DOE and EPA will collaborate on fuels testing as well as EPA’s greenhouse gas policy-making (see section 1.1.5 for more information on Executive Order 13432) to ensure that biofuels contribute to current and future emission reduction requirements. DOE will also partner with DOT who has the lead role to resolve biofuels transport and logistical issues, including assessing material issues with storage containers and pipelines. DOE will work with NIST on the development of appropriate standards. In addition to federal inter- and intra-agency collaborations, DOE will enter into cost-shared collaborative projects with state and local governments and/or regional authorities to implement these activities.

The Program will work closely with colleagues in the FreedomCAR and Vehicle Technology

(FCVT) Program to build on that program’s efforts in developing and deploying alternative vehicle and fuel distribution technologies through the Clean Cities Program and other avenues. Presently, ethanol fuels are the primary focus of achieving the 20 in 10 goal, but other biofuel alternatives, such as green gasoline, biobutanol, biodiesel and renewable diesel will also play a role in achieving the 20 in 10 goal.

Table 3-8: Biofuels Infrastructure Task Summary

<i>Platform Goal: Understand the distribution and end use needs to accommodate projected growth in biofuels production</i>		
WBS Element	Description	Barriers Addressed
6.1 Ethanol Infrastructure		
6.1.1 Ethanol Distribution	<p>2007-2012</p> <ul style="list-style-type: none"> ▪ Collaborate with DOT to test intermediate blends on pipelines and dispensers. ▪ Develop best practices handbook on biofuels safety, standards, and model codes. ▪ Collaborate with DOT to analyze and evaluate distribution infrastructure, in consultation with rail, barge, pipeline, and trucking industries to assess bottlenecks and barriers to effective transport of projected ethanol volumes. ▪ Collaborate with DOT to evaluate the viability of using existing pipelines for ethanol distribution. <p>2013-2017</p> <ul style="list-style-type: none"> ▪ Collaborate with DOT to analyze and evaluate distribution infrastructure needs for other biofuels. ▪ Collaborate with DOT and NIST to develop performance based standards on methods for testing various blends of biofuels for quality assurance. 	<p>Dm-B: Availability of Biofuels-Compatible Vehicles</p> <p>Dt-A: Ethanol Pipeline Distribution Issues</p> <p>Dt-B: Limited Information Available for Developing Codes and Standards</p> <p>Dt-C: Materials Compatibility Issues of Alcohol Fuels</p>
6.1.2 Ethanol End Use	<p>2007-2012</p> <ul style="list-style-type: none"> ▪ Conduct testing of intermediate blends to assess impacts on small engines and vehicle performance, emissions, durability, and other factors. ▪ Assess FFV technology development for mileage and emissions impacts and provide data to vehicle manufacturers. ▪ Evaluate the options for improving performance of/optimizing FFVs for use of ethanol. <p>2013-2017</p> <ul style="list-style-type: none"> ▪ Validate market data on fuel use as a function of vehicle performance, fuel cost, and availability 	<p>Dm-C: Industry and Consumer Acceptance and Awareness</p> <p>Dt-C: Materials Compatibility Issues of Alcohol Fuels</p> <p>Dt-D: Increased Evaporative Hydrocarbon Emissions of Ethanol Blends</p> <p>Dt-E: Ethanol Blend Vehicle Fuel Economy</p>
6.1.3 Ethanol Infrastructure Technical Assistance	<p>2007-2012</p> <ul style="list-style-type: none"> ▪ Work with state and local governments, industry groups, and others to assist in the planning and implementation of strategic infrastructure investments to ensure market penetration of projected ethanol volumes. <p>2013-2017</p> <ul style="list-style-type: none"> ▪ Work with state and local governments, industry groups, and others to assist in the planning and implementation of strategic infrastructure investments to ensure market penetration of other biofuels. 	
6.2 Other Biofuels Infrastructure		

3.4.5 BIOFUELS DISTRIBUTION INFRASTRUCTURE AND END USE MILESTONES AND DECISION POINTS

The key milestones, inputs/outputs and decision points to complete the tasks described in section 3.4.4 are summarized in the chart in Figure 3-26.

Figure 3-26: Biofuels Distribution and End Use Gantt Chart

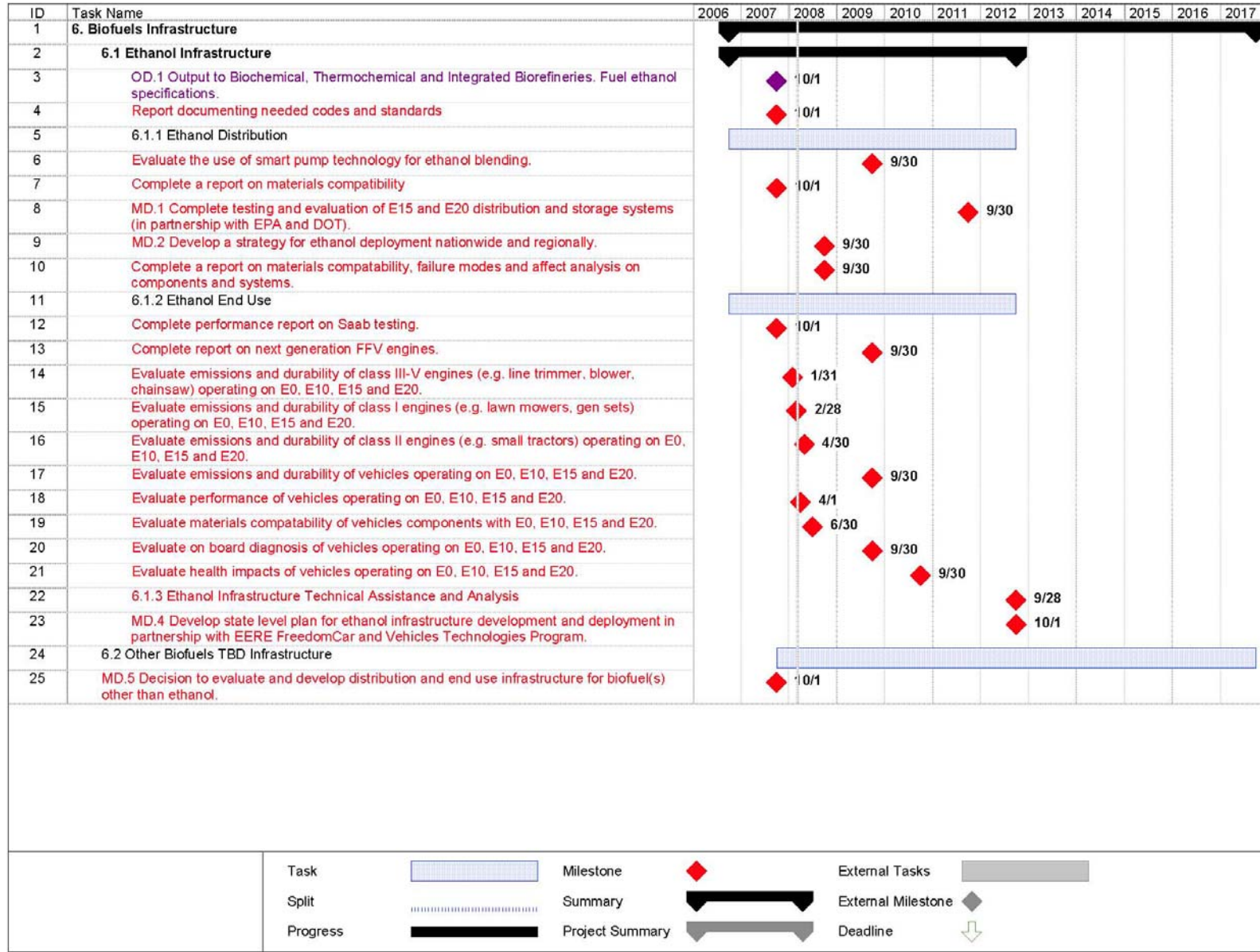

3.5 CROSSCUTTING MARKET TRANSFORMATION

Meeting the President’s goal of increasing the supply of renewable and alternative fuels to 35 billion gallons by 2017 will require significant changes in various sectors of our economy. First, significant and rapid advances in renewable and alternative fuel technologies are needed to ensure cost-effective production of these alternative fuels in significant volumes. Second, significant changes to our agricultural, forestry, and waste management industries will be needed to efficiently supply the required feedstocks for biofuels production. Finally, our nation’s transportation sector, including its fueling infrastructure and automotive fleet, must evolve to accommodate alternative fuels, either as standalone fuels or as blending agents.

The Program is facilitating these changes by engaging in a range of market transformation activities that aim to reduce market barriers across the supply chain and at each stage of development—from research and development through major market penetration. These non-R&D activities can be grouped into three general categories: stakeholder communications and outreach, strategic partnerships, and government policy and regulation. Recognizing that a myriad of conditions and players affect both the supply and demand sides of the market, the Program focuses its efforts on those market elements that it can most readily influence.

The block flow diagram in Figure 3-27 outlines the crosscutting activities that support all five elements of the biomass-to-biofuels supply chain.

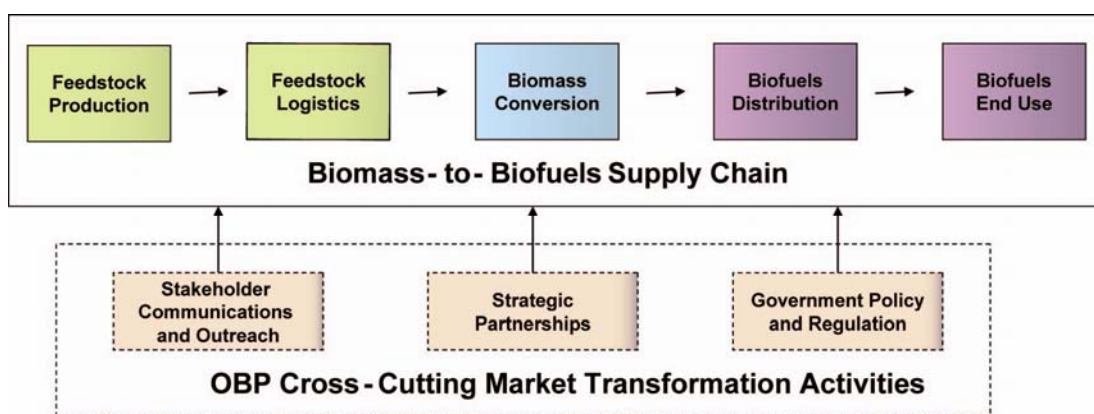

Figure 3-27: Crosscutting Market Transformation Activities Influence All Biomass-to-Biofuels Supply Chain Elements

Stakeholder Communications and Outreach. Stakeholder communications and outreach efforts are focused on education, information exchange and partnerships with key stakeholder groups in the existing agricultural, forestry and transportation fuels industries, government policymakers and regulators, investment/financial community, biomass and biofuels researchers, and the general public.

Strategic Partnerships. The Program is partnering with other federal entities, states and regional organizations, industry groups and international agencies to build support for biofuels and accelerate the dispersion of biomass-based technologies in the marketplace.

Government Policy and Regulation. The Program is working with policy-makers to identify financial incentives, legislative mandates and other policy mechanisms to accelerate the market transformation to biofuels. The Program is also working with international, federal, state and local regulators and codes and standards organizations to develop, modify, and harmonize regulations and standards that will facilitate a new biofuels industry.

Crosscutting Market Transformation Activities Interfaces

Crosscutting activities interface with and impact all elements of the biomass-to-biofuels supply chain and at each stage of development. By their design they provide a major portion of the proverbial “glue” that connects the Program’s technical efforts, both internally and externally.

3.5.1 CROSS-CUTTING MARKET TRANSFORMATION SUPPORT OF PROGRAM STRATEGIC GOALS

Meeting the Program’s strategic goals will require significant changes in the existing agriculture, forest, petroleum fuels (processing and distribution), and automobile manufacturing industries. The strategic goals of the Program’s crosscutting activities are to:

- Accelerate this multi-industry transformation through targeted stakeholder education designed to improve market efficiency through improved knowledge transfer,
- Streamline and leverage critical non-technical activities through strategic partnerships, and
- Develop an efficient and supportive intergovernmental framework through coordination with policy, regulatory, permitting and standards organizations.

The Program’s crosscutting market transformation activities support all seven of the biomass utilization pathways.

3.5.2 CROSS-CUTTING MARKET TRANSFORMATION SUPPORT OF PROGRAM PERFORMANCE GOALS

The performance goals for the Program’s cross-market transformation activities include:

Stakeholder Communications and Outreach

- By 2009, develop four podcasts focused on the Program and bioproducts. The podcasts will be available on the Program website and may also be distributed at events on CD-ROMs and via e-mail to stakeholders.
- By 2009, develop and air two radio spots in two cities at six stations (will air approximately 440 times).
- Exhibit at 10-15 trade shows per year through FY 2010.
- By 2009, develop new Program booth that accurately reflects goals and focus areas. Review and update booth on an annual basis, if required, by replacing panels containing goals and focus areas.
- Write and publish at least three technical articles per year.

- Understand and appropriately respond to concerns about biofuels expressed in the press and elsewhere. Responses can include making adjustments to the program or more clearly articulating DOE's work and objectives.
- By 2009, establish and implement a process to develop and disseminate appropriate news, articles, and tools to stakeholders and consumer groups on a regular basis.
- By 2009, redesign the Program website. Continually maintain the website content. Review the website structure on an annual basis (at a minimum) to ensure that it accurately reflects program activities and targets the appropriate audience.

Strategic Partnerships

- By 2009, arrange meetings with at least 20 Federal, state and regional organizations, industry groups and international agencies to identify partnership opportunities.
- Sponsor or participate in a minimum of 10 relevant partner events, including conferences, workshops, press events, etc. each year.
- Jointly development or contribute to at least 5 partner initiatives each year.

Government Policy and Regulation

- Partner with the Department of Treasury to evaluate the impact of Alternative Fuel Standards on the biofuels market.
- Perform a cost benefit analysis of biofuels incentives.

3.5.3 CROSS-CUTTING MARKET TRANSFORMATION CHALLENGES AND BARRIERS

The Crosscutting Market Transformation addresses following challenges and barriers as detailed in sections 1.1.4:

- Cost of production
- High risk of large capital investments
- Agricultural sector-wide paradigm shift
- Inadequate supply chain infrastructure
- Lack of industry standards and regulations
- Industry and consumer acceptance and awarenesslack of biofuels distribution infrastructure
- Availability of biofuels-compatible vehicles
- Lack of understanding of environmental/ energy tradeoffs

3.5.4 APPROACH FOR OVERCOMING CROSS-CUTTING MARKET TRANSFORMATION CHALLENGES AND BARRIERS

The approach for overcoming crosscutting challenges and barriers is outlined in the work breakdown structure (WBS), as shown in Figure 3-28. The current efforts are focused on stakeholder communications, strategic partnerships and government policy and regulation. To leverage EERE resources and expertise, the Program is collaborating with other DOE Offices

and Programs, as well as other member agencies of the Biomass R&D Board, in the design and implementation of its market transformation strategy.

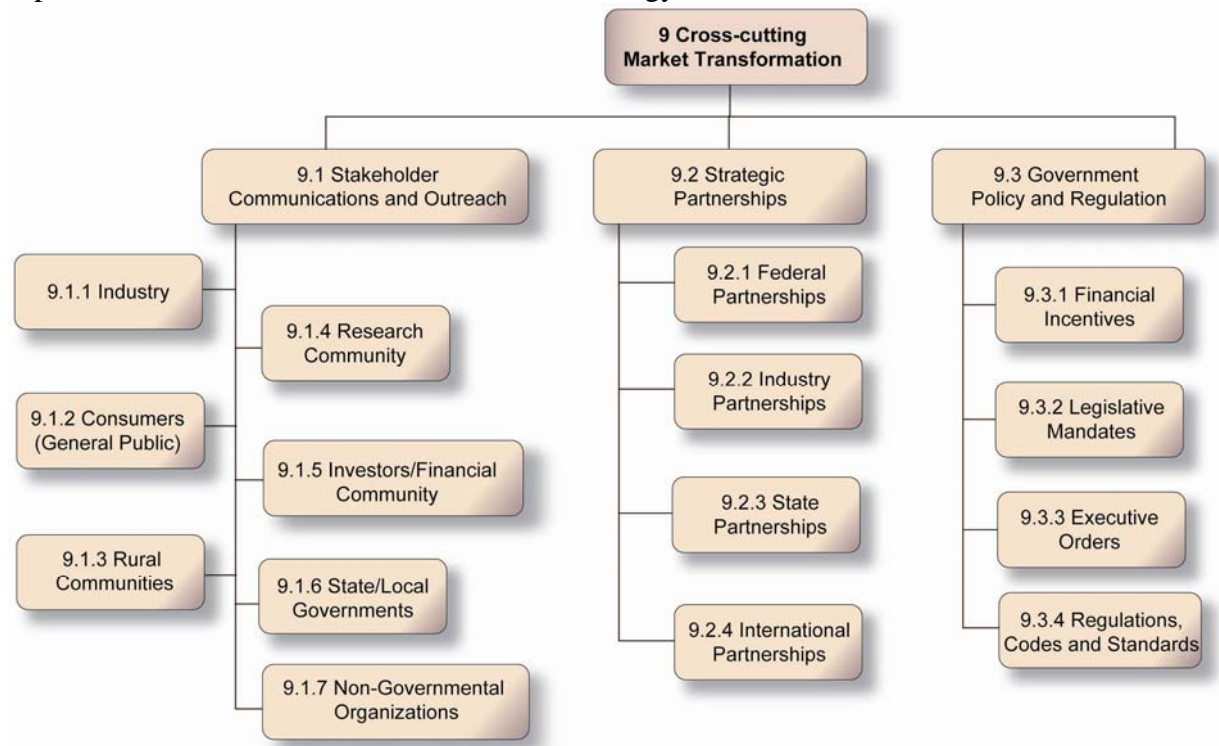

Figure 3-28: Crosscutting Market Transformation Work Breakdown Structure

The Crosscutting Issues WBS is organized around three key tasks, as follows.

WBS 9.1 Stakeholder Communications and Outreach

The Program will facilitate information exchange between industry stakeholders through workshops, web-based tools and databases, technical training and education. Communication products and approaches will be tailored to specific stakeholder audiences. The Program's public outreach will focus on informing and educating consumers and the finance community on biomass and biofuels, enabling them to make informed decisions, focusing on dispelling myths and explaining the benefits associated with the production and use of biomass-based fuels. Outreach information will be disseminated via a mix of print, internet, radio, television.

WBS 9.2 Strategic Partnerships

Effective partnerships and strategic alliances indirectly support market transformation by providing opportunities for the Program to reach across key industries and markets of the biomass-to-biofuels supply chain, leverage a broad base of expertise, and jointly solve biofuels-related issues that will create a solid technical and business foundation for a future bioindustry. The Program is partnering with other federal entities, industry, state and regionally-based organizations and international agencies to build support for biofuels and accelerate the diffusion of biomass-based technologies into the marketplace.

WBS 9.3 Government Policies and Regulation

Government policies can have a dramatic impact on the speed of market transformation. The

Program’s goal is to identify the best policy options and their projected impacts on deploying biofuels, and work with the EERE Office of Planning, Budget and Analysis and the DOE Office of Policy and International Affairs to inform decision-makers and motivate implementation of effective federal policies. The Program is also working with domestic and international regulatory agencies to harmonize the requirements of the multitude of regulations, codes and standards that apply to biomass-based technologies and systems, establish a clear strategy for permitting between various levels of government, federal and state agencies, and identify opportunities to streamline permitting and regulation requirements.

Activities for each of these tasks are outlined in Table 3-9.

Table 3-9. WBS 9.0 Crosscutting Issues Task Summary

WBS Element	Description	Barriers Addressed
<i>Platform Goal: Develop systematic approach to building a cost-effective infrastructure system that will be adaptable to changing needs to ensure widespread biofuel use for transportation.</i>		
9.1 Stakeholder Communications and Outreach		
9.1.1 Industry	Identify industry concerns, build support and encourage industry to take the actions required to deploy biofuels into the marketplace. 2007-2012 <ul style="list-style-type: none"> • Facilitate communications and sharing of biomass and biofuels technology and policy needs • Coordinate industry communications efforts with other federal agencies 2013-2017 <ul style="list-style-type: none"> • TBD 	Dm-C. Industry and Consumer Acceptance and Awareness
9.1.2 Consumers (General Public)	Increase public acceptance and build broad support and consumer commitment to biofuels. 2007-2012 <ul style="list-style-type: none"> • Create public outreach campaign to educate public on biomass feedstocks (ex. food vs. energy, genetically modified organism (GMO), etc.) and on misconceptions with biomass conversion (ex. energy inputs/outputs, environmental benefits etc.) • Coordinate communications efforts with DOE FCVT Program (e.g., Clean Cities, E85 Infrastructure Group) 2013-2017 <ul style="list-style-type: none"> • TBD 	Dm-C. Industry and Consumer Acceptance and Awareness
9.1.3 Rural Communities	Educate farmers and forest managers regarding biomass supply to biorefineries. 2007-2012 <ul style="list-style-type: none"> • Coordinate communications efforts with USDA • Partner with regional groups, states and universities 2013-2017 <ul style="list-style-type: none"> • TBD 	Dm-C. Industry and Consumer Acceptance and Awareness
9.1.4 Research Community	Stimulate R&D investment and technology innovation that will advance development of cost-effective feedstock and conversion technologies and support biorefinery demonstrations for the production of advanced biofuels 2007-2012 <ul style="list-style-type: none"> • Develop and implement information exchange and dissemination tools with a focus on cellulosic ethanol and other near term advanced biofuels 2013-2017 <ul style="list-style-type: none"> • Expand to fully cover other advanced biofuels, bioproducts and biopower 	Dm-C. Industry and Consumer Acceptance and Awareness
9.1.5 Investors/Financial Community	Stimulate business interests in building infrastructure across the supply chain including production facilities, distribution infrastructure, vehicle fleets, fueling stations, harvesters and other necessary equipment as well as the supporting service network. 2007-2012 <ul style="list-style-type: none"> • Identify potential benefits of investing in infrastructure development with a focus on cellulosic ethanol and other near term advanced biofuels 2013-2017	Dm-C. Industry and Consumer Acceptance and Awareness

	<ul style="list-style-type: none"> Expand to fully cover other advanced biofuels 	
9.1.6 State/Local Governments	<p>Promote state and local government leadership in environmental responsibility and energy diversification. 2007-2012</p> <ul style="list-style-type: none"> Educate state and local policymakers/regulators on biomass technology and policy issues Develop training seminars for first responders and public safety officials Track state and local biomass initiatives. <p>2013-2017</p> <ul style="list-style-type: none"> TBD 	Dm-C. Industry and Consumer Acceptance and Awareness
9.1.7 Non-Governmental Organizations	<p>Understand concerns and provide objective data and information about the characteristics of biofuels covering the entire life cycle. 2007-2012</p> <ul style="list-style-type: none"> Focus on cellulosic ethanol and other near term advanced biofuels <p>2013-2017</p> <ul style="list-style-type: none"> Expand to fully cover other advanced biofuels 	Dm-C. Industry and Consumer Acceptance and Awareness
9.2 Stakeholder Partnerships		
9.2.1 Federal Partnerships	<p>Partner with federal entities to leverage limited funds, avoid duplication of effort, and ensure consistent message. (This effort will likely result in identification of RDD&D projects that would be placed in the appropriate technical element) 2007-2012</p> <ul style="list-style-type: none"> Co-lead Biomass R&D Board with USDA <ul style="list-style-type: none"> Develop national biofuels action plan to coordinate efforts of USDA, EPA, DOC/NIST, DOT, NSF, DOI and DOD (see Table 1-1) through the Board Coordinate with other EERE programs (e.g. FCVT, Clean Cities, Industry) <ul style="list-style-type: none"> Incorporate interface activities in respective Program plans Identify, prioritize and execute biofuels market transformation initiatives Coordinate with other DOE Offices (PI, SC, FE) <ul style="list-style-type: none"> Incorporate interface activities in respective Program plans Identify, prioritize and execute biofuels market transformation initiatives Co-fund projects with USDA under the annual joint solicitation (directed by Biomass R&D Initiative) <p>2013-2017</p> <ul style="list-style-type: none"> TBD 	Im-B. Lack of Feedstock Infrastructure Dm-A. Lack of Biofuels Distribution Infrastructure; Dm-B. Availability of Biofuels-Compatible Vehicles; Im-D. Biorefinery Plant Economics; Dm-C. Industry and Consumer Acceptance and Awareness
9.2.2 Industry Partnerships	<p>Leverage industry expertise and resources to accelerate market transformation. 2007-2012</p> <ul style="list-style-type: none"> Implement the recommendations of the Biomass Technical Advisory Committee. Join existing (such as the FreedomCAR and Fuel Partnership) and/or establish new public-private partnership to provide consensus industry perspective to Program strategies and plans. <p>2013-2017</p> <ul style="list-style-type: none"> TBD 	Im-B. Lack of Feedstock Infrastructure; Im-D. Biorefinery Plant Economics; Dm-C. Industry and Consumer Acceptance and Awareness
9.2.3 State Partnerships	<p>Forge state and local partnerships to facilitate communication, coordination and leveraging of resources. 2007-2012</p> <ul style="list-style-type: none"> Work with National Biomass State and Regional Partnership to encourage policies that promote biofuels production and use. Partner with state/regional network organizations (Governors Ethanol Coalition, Sun Grant Universities, National Council of State Legislators, U.S. Conference of Mayors, etc.) to implement biofuels development activities at a state/regional level <p>2013-2017</p> <ul style="list-style-type: none"> TBD 	Im-A. Political and Competitive Environment; Im-B. Lack of Feedstock Infrastructure Dm-A. Lack of Biofuels Distribution Infrastructure; Dm-B. Availability of Biofuels-Compatible Vehicles; Dm-C. Industry and Consumer Acceptance and Awareness
9.2.4 International Partnerships	<p>Enhance information exchange and cooperation between the Program and biofuels experts from other countries. 2007-2012</p> <ul style="list-style-type: none"> Represent the U.S. in International Energy Agency (IEA) Bioenergy Implementing Agreement (Tasks 39 and 41) Participate in United Nations International Biofuels Forum Lead US/Brazil Collaboration Partner with other ethanol-producing countries 	Dm-C. Industry and Consumer Acceptance and Awareness

	2013-2017 • TBD	
9.3 Government Policy and Regulation		
9.3.1 Financial Incentives	Identify, promote and execute financial incentives to accelerate the adoption and penetration of biomass technologies and systems into the marketplace. 2007-2012 • Track and guide development of federal financial incentives related to biomass and biofuels • Define and execute market development incentive programs • Track and guide development of state financial incentives related to biomass and biofuels 2013-2017 • TBD	Im-A. Political and Competitive Environment; Im-D. Biorefinery Plant Economics; Im-C. Lack of Consideration of Externalities; Dm-C. Industry and Consumer Acceptance and Awareness
9.3.2 Legislative Mandates	Identify, promote and execute legislative mandates to increase the diffusion rates of new biomass technologies and systems. 2007-2012 • Execute EPACT 2005 Section 942 bulk purchase of ethanol via reverse auction mechanism • Collaborate with FCVT to implement EPACT 2005 tax credits for alternative fuel vehicles and stations, track fleet acquisition of AFVs • Track renewable fuels use with respect to EPACT 2005 renewable fuel standard 2013-2017 • TBD as new legislative mandates are issued	Im-A. Political and Competitive Environment; Im-B. Lack of Feedstock Infrastructure Dm-A. Lack of Biofuels Distribution Infrastructure; Dm-B. Availability of Biofuels-Compatible Vehicles; Dm-C. Industry and Consumer Acceptance and Awareness
9.3.3 Executive Orders	Carry out executive orders to increase the diffusion rates of new biomass technologies and systems. 2007-2012 • Cooperate with EPA, DOT, USDA to address greenhouses gas emissions from vehicles (EO 13432) • Reduce petroleum consumption and increase alternative fuel use (EO 13423) 2013-2017 • TBD as new EOs are issued	Dm-C. Industry and Consumer Acceptance and Awareness
9.3.4 Regulations, Codes and Standards	Work with domestic and international regulation, codes and standards organizations to harmonize requirements and streamline processes. 2007-2012 • Participate in development/modification of consistent codes, standards and regulations to enable biorefinery construction/operation (ANSI, EPA) • Participate in development/modification of consistent codes, standards and regulations to enable and promote use of biomass based products (USDA, NIST, ASTM) • Collaborate with UL to develop safety standards for E85 fuel dispensing systems 2013-2017 • TBD	Im-E. Lack of Industry Standards and Regulations; Dm-C. Industry and Consumer Acceptance and Awareness

3.5.5 CROSSCUTTING MARKET TRANSFORMATION MILESTONES AND DECISION POINTS

The key crosscutting market transformation milestones, inputs/outputs and decision points to complete the tasks described in section 3.5.4 are summarized in the chart in Figure 3-29.

Figure 3-29: Crosscutting Market Transformation Gantt Chart

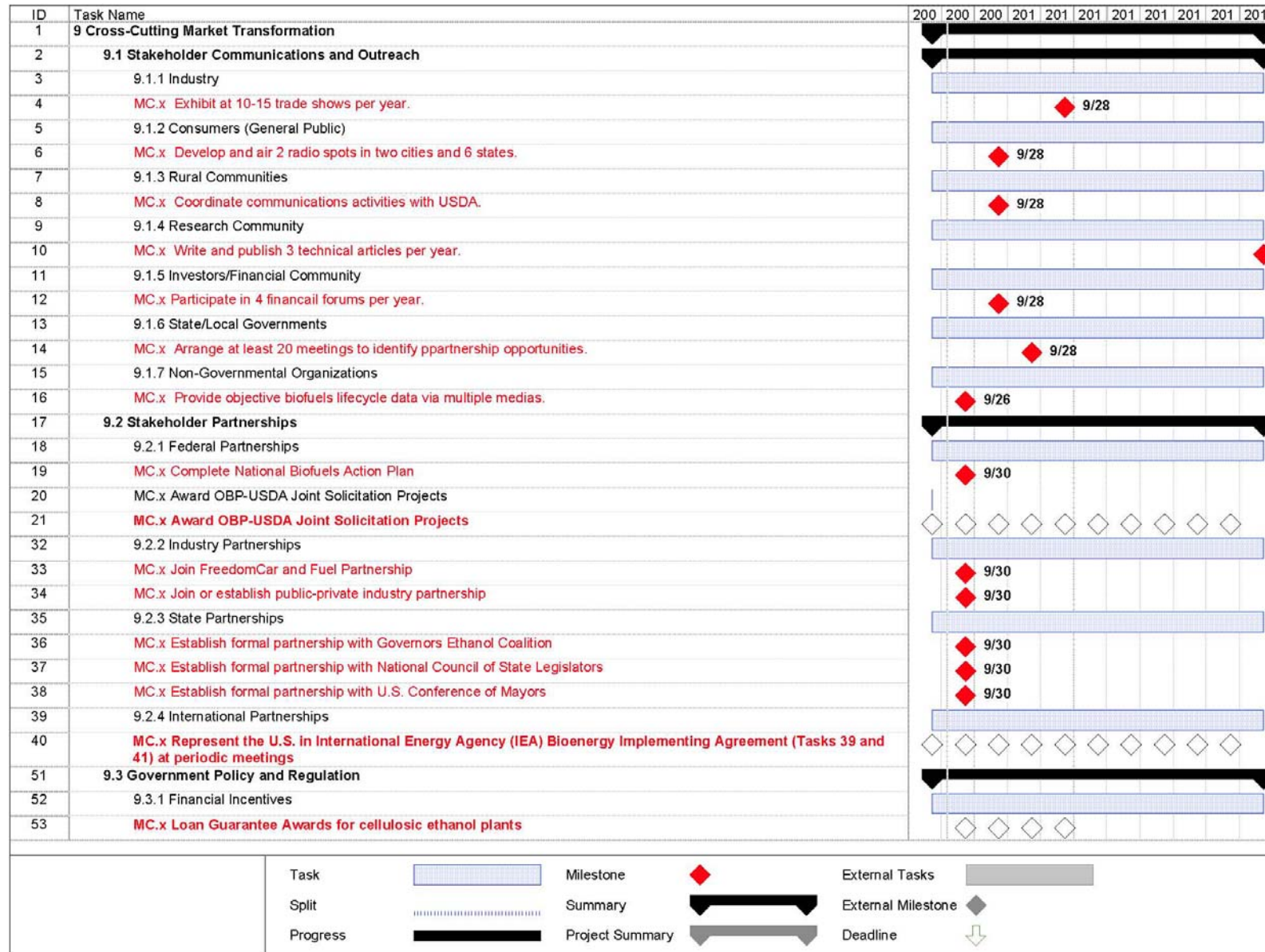

APPENDIX A: BIOMASS PROGRAM BIOREFINERY PATHWAYS

High-level block flow diagram for each Program biorefinery pathway is presented in Figures A-1 through A-7 and identifies the current process (if it exists today) and current products including fuels, chemicals and power, the options for improvements and the associated new products. *The diagrams are not intended to be all inclusive and many other viable processing options are possible.*

Milestones for each biorefinery pathway shown in Figures A-1 through A-6 are listed in Table A-1, following the pathway diagrams. Each block on pathway figures has a B-level pathway milestone associated with it that is included in the table. The Program priority level and platform responsibilities are shown for each B-level milestone, as well as the underlying C-level pathway milestones that support it.

The blocks and paths on the diagrams are coded as follows:

- Green – Feedstocks R&D
- Blue – Biochemical Conversion R&D
- Teal – Thermochemical Conversion R&D
- Boldly outlined blocks – Highest priorities
- Dash outlined blocks – Medium and low priorities
- Black lines – New routes to biofuels, with the heavy lines indicating the highest priority routes
- Tan boxes – Potential new enabling non-fuel products
- Boxes with red outlines and red lines – Existing processing steps in current biorefineries
- Pink diamond on a process stream – Indicates that an “option” exists on how to process the stream. The options must be evaluated and compared against each other to identify the best overall pathway configuration. For pathways representing existing industry segments, the options include the status quo. The options analysis may compare options that would take the full stream or fractions of the full stream. The ability to add and evaluate options within a pathway results in a flexible framework for considering innovative new ideas in the future.

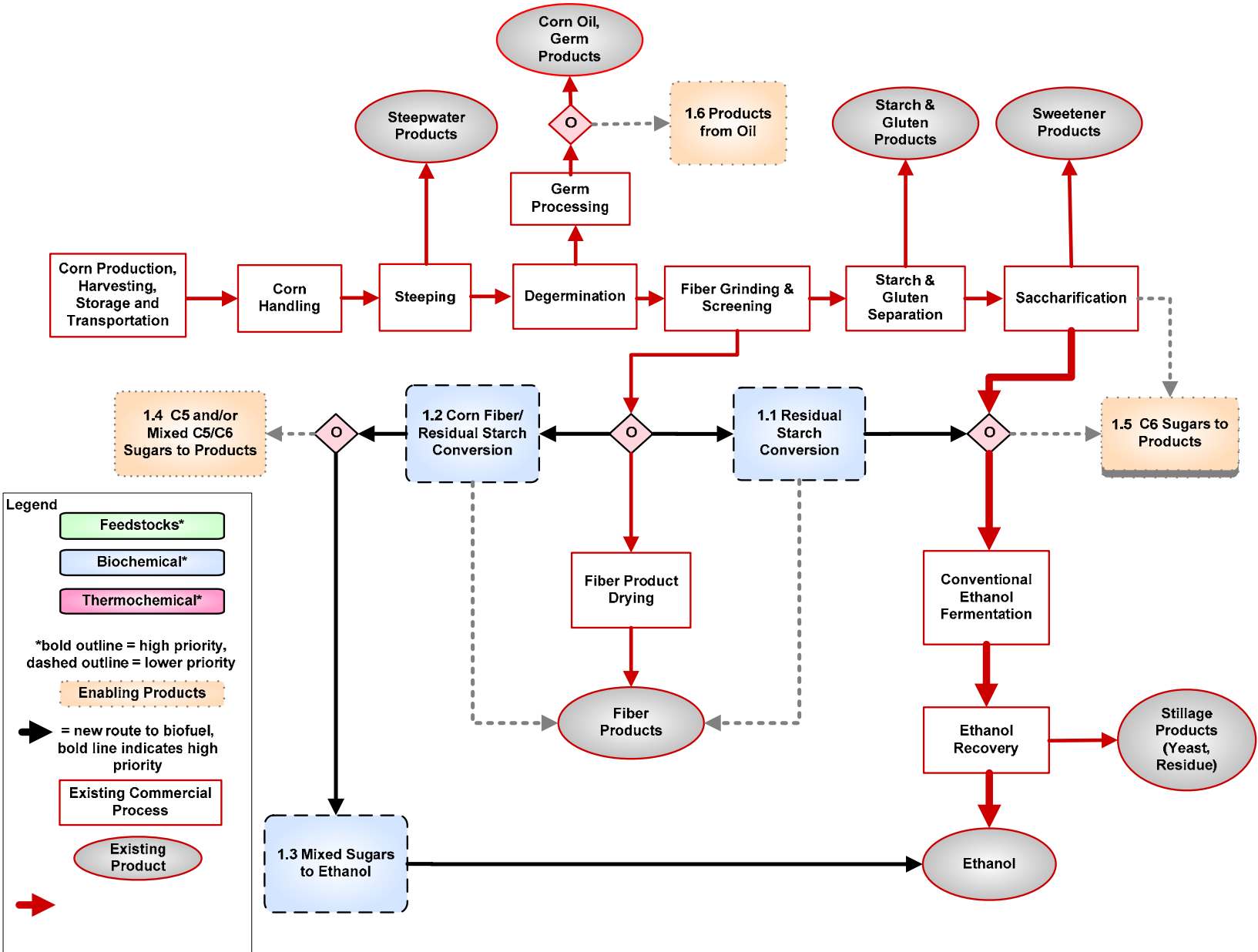

Figure A-1: Corn Wet Mill Improvements Pathway with Emphasis on Biofuels Routes

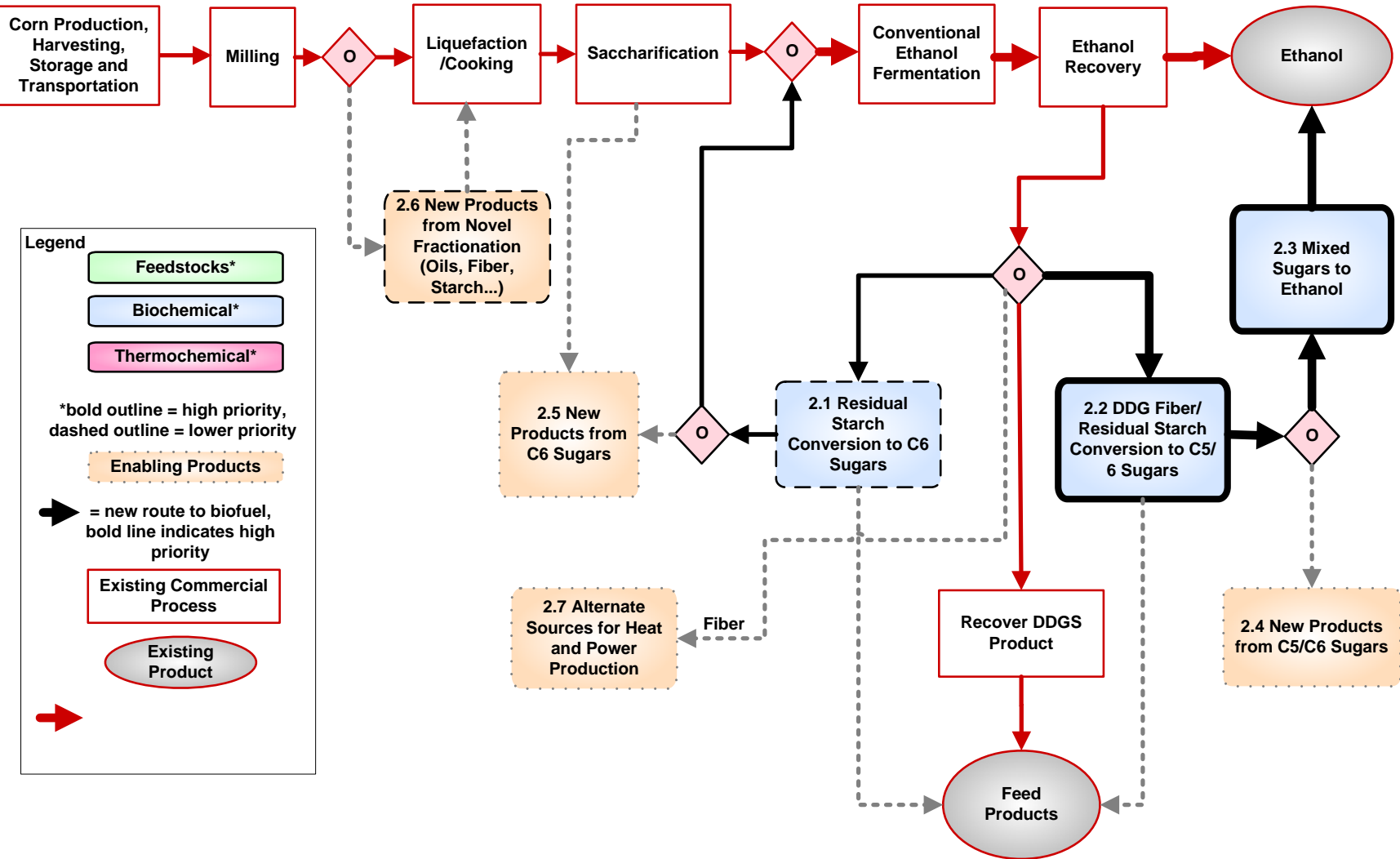

Figure A-2: Corn Dry Grind Mill Improvements Pathway with Emphasis on Biofuels Routes

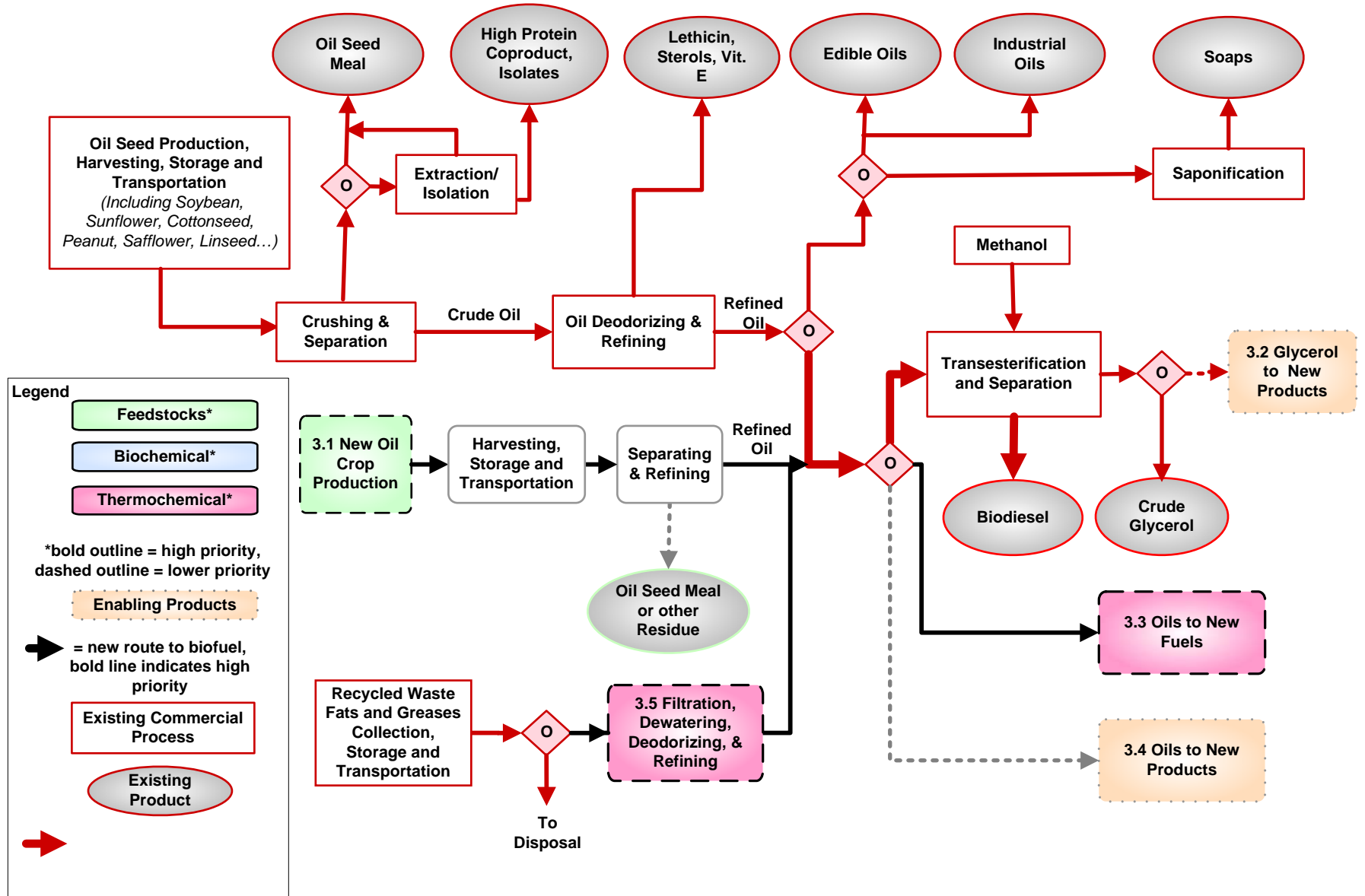

Figure A-3: Natural Oils Processing Pathway with Emphasis on Biofuels Routes

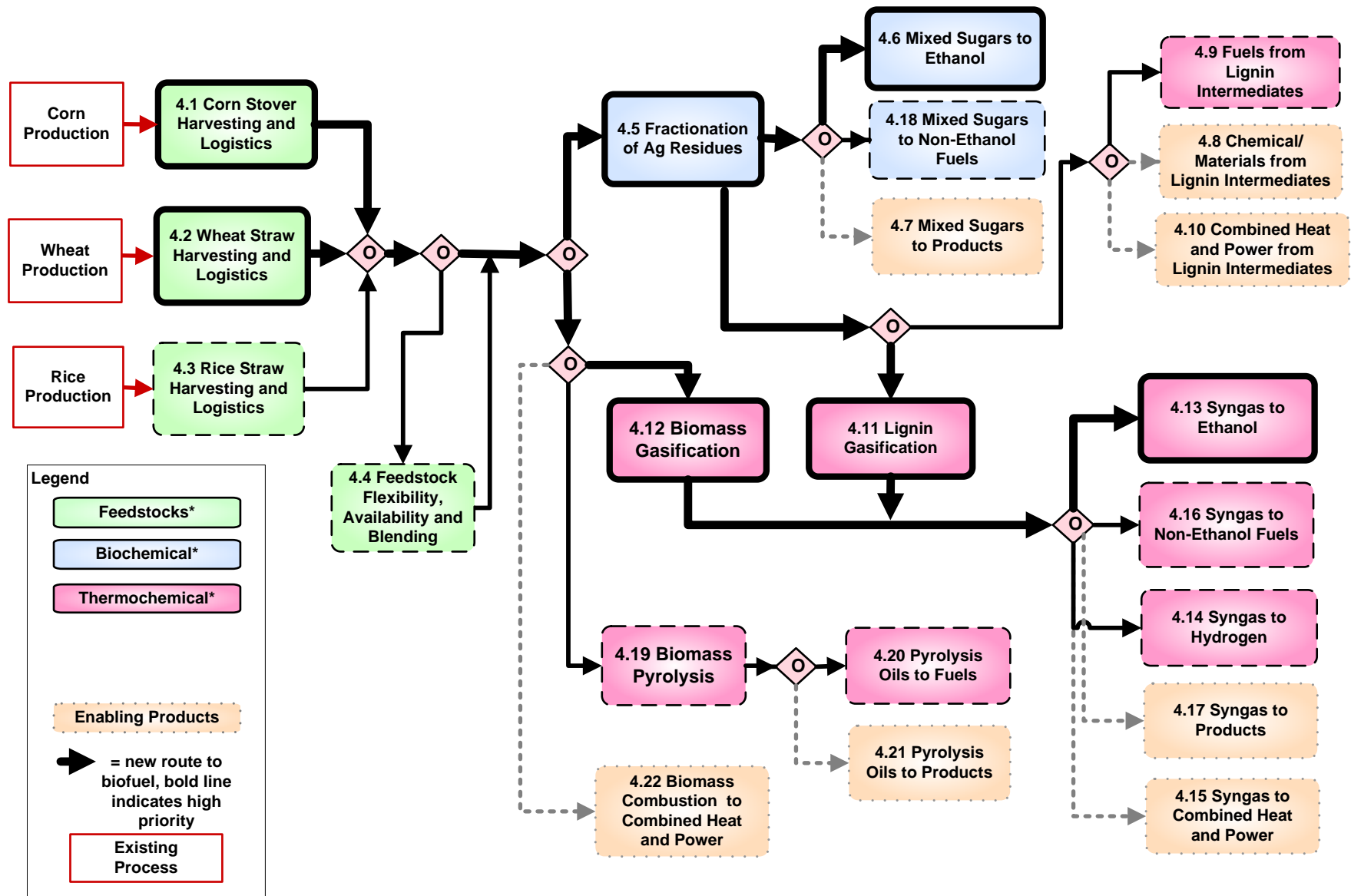

Figure A-4: Agricultural Residue Processing Pathway with Emphasis on Biofuels Routes

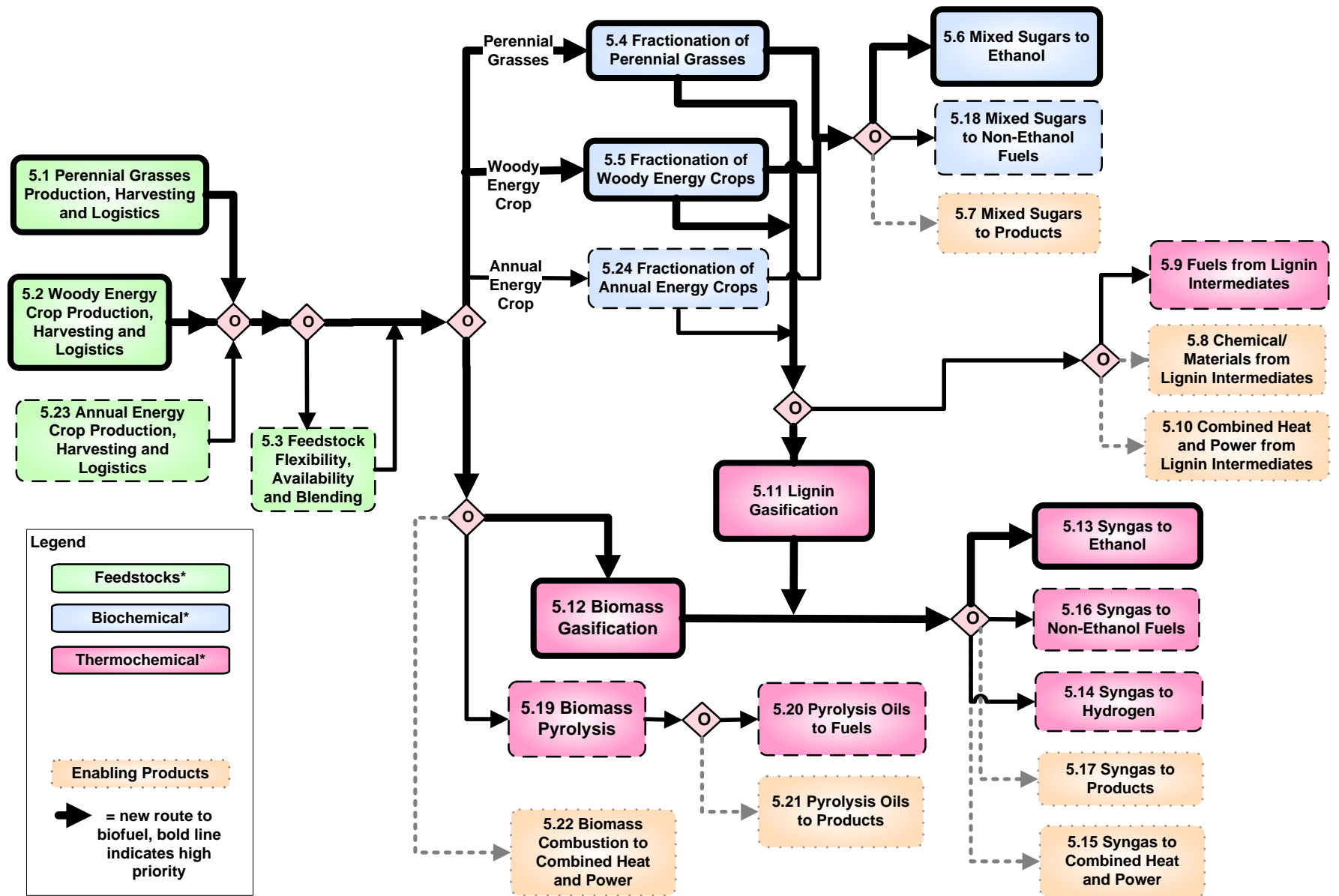

Figure A-5: Energy Crop Processing Pathway with Emphasis on Biofuels Routes

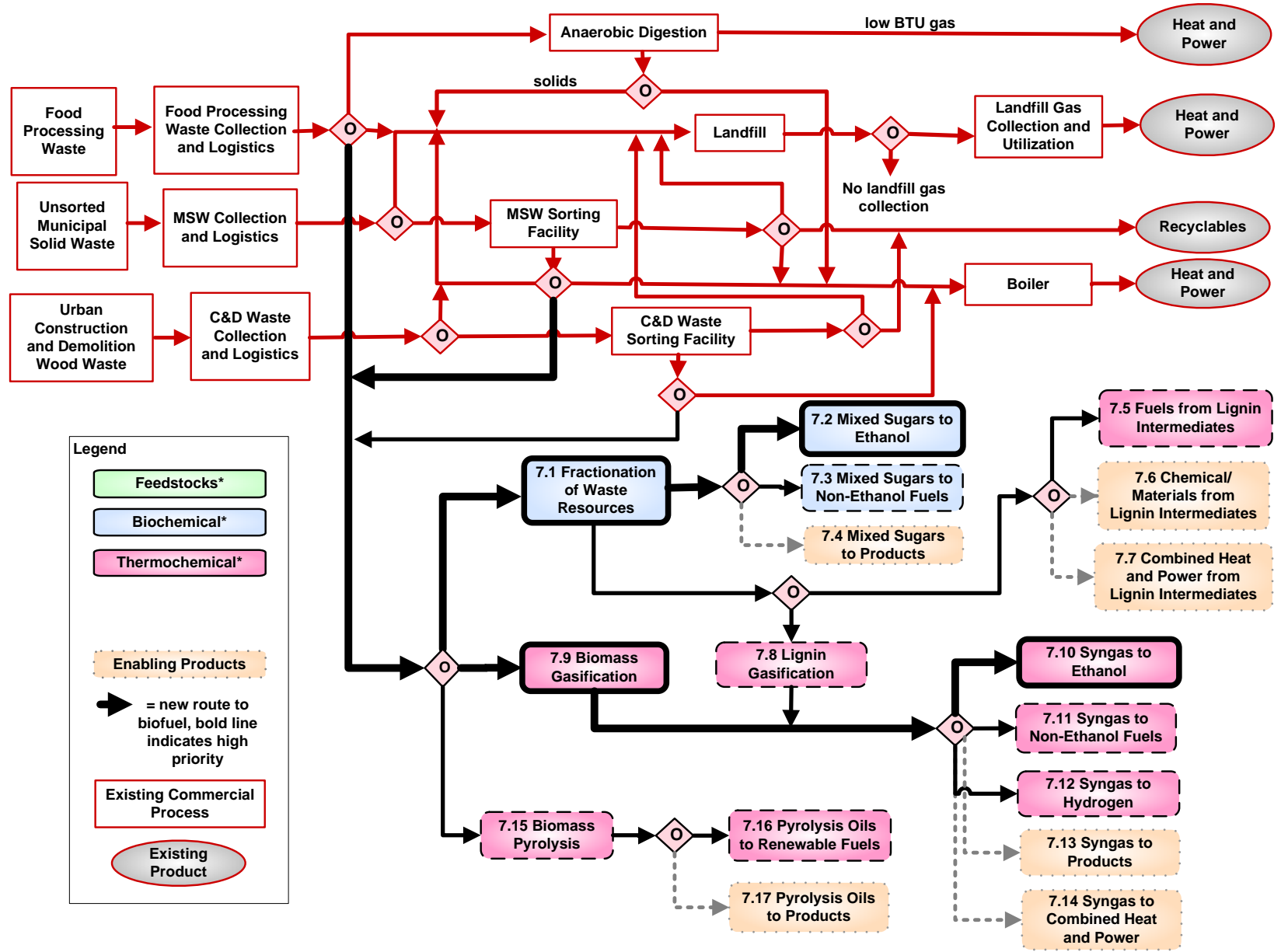

Figure A-7: Waste Processing Pathway with Emphasis on Biofuels Routes

Table A-1: Biorefinery Pathway Milestones

1. Wet Mill Improvements Pathway					
Overview: The corn wet mill improvements for fuel production are focused on developing and demonstrating new processes that use the residual fiber stream from the grinding/screening process to produce additional ethanol. The sugars extracted from the residual starch and fiber can also be used to produce bio-products; the extracted corn oil from the germ processing step can also be converted to new bio-products.					
Milestone #	Type	Sector Biorefinery Pathways/Milestone Titles	Priority (H, M, L)	Stage	Platform
M 1	A	Complete systems level demonstration and validation of technologies to improve corn wet mill facilities using corn grain feedstock			
M 1.1	B	Demonstrate and validate economical residual starch conversion in a wet mill	L		IB
M 1.1.1	C	Convert residual starch in fiber stream to EtOH			
M 1.1.2	C	Evaluate new feed product			
M 1.1.3	C	Validate integrated process at pilot scale		3	
M 1.1.4	C	Validate new process in wet mill		4	IB
M 1.2	B	Demonstrate and validate economical fiber conversion to C5 and/or mixed C5/C6 sugars in a wet mill (residual starch also expected to be converted during fiber processing)	L		IB
M 1.2.1	C	Solubilize hemicellulose in fiber to C5 sugars			
M 1.2.2	C	Hydrolyze cellulose to C6 Sugar			
M 1.2.3	C	Validate integrated process at pilot scale			
M 1.2.4	C	Evaluate new feed product		3	
M 1.2.5	C	Validate new process in wet mill		4	IB
M 1.3	B	Demonstrate and validate economical conversion of mixed sugars to ethanol in a wet mill	L		IB
M 1.3.1	C	Convert released sugars to ethanol			
M 1.3.2	C	Validate integrated process at pilot scale		3	
M 2.3.3	C	Validate new process in wet mill		4	IB
M 1.4	B	Demonstrate and validate economical new products from C5 or mixed C5/C6 sugars in a wet mill	L		IB
M 1.4.1	C	Convert released C5 sugars to products			
M 1.4.2	C	Convert C5 sugars to building block chemicals			
M 1.4.3	C	Convert mixed sugars to products			
M 1.4.4	C	Convert mixed sugars to building block chemicals			
M 1.4.5	C	Convert building block chemicals to products			
M 1.4.6	C	Demonstrate product separation and recovery specification			
M 1.4.10	C	Validate integrated process at pilot scale		3	
M 1.4.11	C	Validate new process in wet mill		4	IB
M 1.5	B	Demonstrate and validate economical new products from C6 sugars in a wet mill	L		IB
M 1.5.1	C	Convert C6 sugars to products			
M 1.5.2	C	Convert C6 sugars to building block chemicals			
M 1.5.3	C	Convert building block chemicals to products			
M 1.5.3	C	Demonstrate product separation and recovery specification			
M 1.5.4	C	Validate integrated process at pilot scale		3	
M 1.5.5	C	Validate new process in wet mill		4	IB
M 1.6	B	Demonstrate and validate economical new products from corn-derived oils in a wet mill	L		IB
M 1.6.1	C	Convert corn derived oils to products			
M 1.6.2	C	Demonstrate product separation and recovery specification			
M 1.6.3	C	Validate integrated process at pilot scale		3	
M 1.6.4	C	Validate new process in wet mill		4	IB

2. Dry Mill Improvements Pathway					
<p>Overview: The corn dry mill improvements for fuel production are focused on developing and demonstrating new processes that use the residual stream (stillage) from the ethanol recovery process to produce additional ethanol. The sugars extracted from the residual starch and fiber; the C6 sugars produced in the saccharification step ; and the corn meal from the initial grinding step can also be converted to new bio-products . In addition, the residual fiber stream from the corn fiber conversion process and/or corn stover (brought into the plant specifically for this purpose) could be used to produce heat and power for the facility.</p>					
Milestone #	Type	Sector Biorefinery Pathways/Milestone Titles	Priority (H, M, L)	Stage	Platform
M 2	A	Complete systems level demonstration and validation of technologies to improve corn dry mill facilities using corn (or other) grain feedstock			
M 2.1	B	Demonstrate and validate economical residual starch conversion in a dry mill	L		IB
M 2.1.1	C	Conversion of residual starch to glucose			
	C	Conversion of converted glucose to ethanol			
M 2.1.2	C	Evaluate new feed product			
M 2.1.4	C	Validate integrated process in a dry mill		4	IB
M 2.2	B	Demonstrate and validate economical fiber conversion in a dry mill (residual starch also expected to be converted during fiber processing)	H		BC/IB
M 2.2.1	C	Convert fiber to monomer sugars			
M 2.2.2	C	Evaluate new feed product			
M 2.2.3	C	Validate integrated process at pilot scale		3	
M 2.2.4	C	Validate new process in dry mill		4	IB
M 2.3	B	Demonstrate and validate economical conversion of mixed sugars to ethanol in a dry mill	H		BC/IB
M 2.3.2	C	Convert released sugars to ethanol			
M 2.3.4	C	Validate integrated process at pilot scale		3	
M 2.3.5	C	Validate new process in dry mill		4	IB
M 2.4	B	Demonstrate and validate economical conversion of mixed sugars to products in a dry mill	L		IB
M 2.4.1	C	Conversion targets from C6 sugars to building blocks			
M 2.4.2	C	Conversion targets from building blocks to products			
M 2.4.3	C	Demonstrate product separation and recovery specification			
M 2.4.4	C	Validate integrated process at pilot scale		3	
M 2.4.5	C	Validate new process in dry mill		4	IB
M 2.5	B	Demonstrate and validate economical new products from C6 sugars in a dry mill	L		IB
M 2.5.1	C	Conversion targets from C6 sugars to building blocks			
M 2.5.2	C	Conversion targets from building blocks to products			
M 2.5.3	C	Product separation specification			
M 2.5.4	C	Validate integrated process at pilot scale		3	
M 2.5.5	C	Validate new process in dry mill		4	IB
M 2.6	B	Demonstrate and validate economical front end fractionation processes in a dry mill	L		
M 2.6.1	C	Derive additional value added products from front end fractionation			
M 2.6.2	C	Evaluate new feed coproducts			
M 2.6.3	C	Validate integrated process at pilot scale		3	
M 2.6.4	C	Validate new process in dry mill		4	IB
M 2.7	B	Investigate alternate sources for dry mill heat and power	L		IB
M 2.7.1	C	Thermochemical processing of fiber stream to heat, power			
M 2.7.2	C	Thermochemical processing of residues (i.e. corn stover) to heat, power			
M 2.7.3	C	Validate integrated process at pilot scale		3	
M 2.7.4	C	Validate new process in dry mill		4	IB

3.0 Natural Oils Processing Pathway					
Overview: The natural oil refining process improvements for fuel production are focused on developing and demonstrating low-cost recycled fats and greases, and oil seed feedstocks to produce additional biodiesel in existing biodiesel production facilities. The refined oils from the oil seeds and the glycerol by-product stream can also be converted to new bioproducts.					
Milestone #	Type	Sector Biorefinery Pathways/Milestone Titles	Priority (H, M, L)	Stage	Platform
M 3	A	Complete systems level demonstration and validation of technologies to improve oil processing mill facilities			
M 3.1	B	Demonstrate and validate economical and sustainable new oil crop production for production of biodiesel and other renewable diesel alternatives	L		F
M 3.1.1	C	Demonstrate sustainable agronomic practices			
M 3.1.2	C	Demonstrate oil crop harvesting			
M 3.1.3	C	Demonstrate oil crop storage			
M 3.1.4	C	Demonstrate oil crop transportation			
M 3.1.5	C	Demonstrate quality and quantity of oil crop available			
M 3.1.7	C	Validate integrated oil crop logistics at pilot scale		3	
M 3.1.8	C	Validate integrated oil crop logistics at demonstration scale		4	IB
M 3.2	B	Demonstrate and validate economical new products from glycerol in a natural oil processing facility	L		IB
M 3.2.1	C	Convert glycerol to products			
M 3.2.2	C	Recover new products			
M 3.2.3	C	Validate integrated process at pilot scale		3	
M 3.2.4	C	Validate integrated process in natural oil processing facility		4	IB
M 3.3	B	Demonstrate and validate economical new fuels from oils in natural oil processing facility	L		TC/IB
M 3.3.1	C	Convert oil to fuels			
M 3.3.2	C	Recover fuels			
M 3.3.3	C	Validate integrated process at pilot scale		3	
M 3.3.4	C	Validate integrated process in natural oil processing facility		4	IB
M 3.4	B	Demonstrate and validate economical new products from oils in natural oil processing facility	L		IB
M 3.4.1	C	Convert oil to products			
M 3.4.2	C	Convert oils to building block chemicals			
M 3.4.3	C	Convert building block chemicals to products			
M 3.4.4	C	Recover new products			
M 3.4.5	C	Validate integrated process at pilot scale		3	
M 3.4.6	C	Validate integrated process in natural oil processing facility		4	IB
M 3.5	B	Demonstrate and validate economical cleanup of waste fats and greases for fuel production	L		IB
M 3.5.1	C	Validate cleanup performance			
M 3.5.2	C	Validate integrated cleanup at pilot scale		3	
M 3.5.3	C	Validate integrated process in natural oil processing facility		4	IB

4. Agricultural Residue Processing Pathway

Overview: Fuel production options for agricultural residues are focused on developing and demonstrating integrated biochemical and thermochemical processes and systems. The mixed sugars from the fractionation process can also be converted to bioproducts; syngas can be converted chemicals, and heat and power; lignin intermediates can be converted to chemicals, materials and heat and power; and pyrolysis oil can be converted into chemicals.

Milestone #	Type	Sector Biorefinery Pathways/Milestone Titles	Priority (H, M, L)	Stage	Platform
M 4	A	Complete systems level demonstration and validation of all key technologies to utilize agricultural residue feedstocks in existing or new facilities			
M 4.1	B	Demonstrate and validate integrated corn stover harvesting logistics	H	4	F/IB
M 4.1.1	C	Demonstrate sustainable corn agronomic practices that account for corn stover harvesting			
M 4.1.2	C	Demonstrate wet and dry corn stover harvesting			
M 4.1.3	C	Demonstrate wet and dry corn stover storage			
M 4.1.4	C	Demonstrate wet and dry corn stover transportation			
M 4.1.5	C	Demonstrate wet and dry quality and quantity of corn stover available			
M 4.1.6	C	Demonstrate corn stover preprocessing benefits			
M 4.1.7	C	Validate integrated corn stover logistics at pilot scale		3	
M 4.1.8	C	Validate integrated corn stover logistics at demonstration scale		4	IB
M 4.2	B	Demonstrate and validate integrated wheat straw harvesting logistics	H		F/IB
M 4.2.1	C	Demonstrate sustainable wheat agronomic practices that account for wheat straw harvesting			
M 4.2.2	C	Demonstrate wet and dry wheat straw harvesting			
M 4.2.3	C	Demonstrate wet and dry wheat straw storage			
M 4.2.4	C	Demonstrate wet and dry wheat straw transportation			
M 4.2.5	C	Demonstrate wet and dry quality and quantity of wheat straw available			
M 4.2.6	C	Demonstrate wheat straw preprocessing benefits			
M 4.2.7		Validate integrated wheat straw logistics at pilot scale			
M 4.2.8	C	Validate integrated wheat straw logistics at demonstration scale			IB
M 4.3	B	Demonstrate and validate integrated rice straw harvesting logistics	L		F/IB
M 4.3.1	C	Demonstrate sustainable rice agronomic practices that account for rice straw harvesting			
M 4.3.2	C	Demonstrate wet and dry rice straw harvesting			
M 4.3.3	C	Demonstrate wet and dry rice straw storage			
M 4.3.4	C	Demonstrate wet and dry rice straw transportation			
M 4.3.5	C	Demonstrate wet and dry quality and quantity of rice straw available			
M 4.3.6	C	Demonstrate rice straw preprocessing benefits			
M 4.3.7		Validate integrated rice straw logistics at pilot scale		3	
M 4.3.8	C	Validate integrated rice straw logistics at demonstration scale		4	IB
M 4.4	B	Feedstock Flexibility and Availability via Blending Depot or Elevator	L		F
M 4.4.1	C	To be determined			
M 4.5	B	Demonstrate and validate ag residue fractionation to produce mixed, dilute biomass sugars	H	4	BC/IB
M 4.5.1	C	Validate cellulase enzyme cost			
M 4.5.2	C	Validate pretreatment technology cost			
M 4.5.3	C	Demonstrate ability to economically satisfy internal heat and power demands			
M 4.5.4	C	Validate capital cost			
M 4.5.5	C	Validate integrated pretreatment and enzymatic hydrolysis at pilot scale		3	
M 4.5.6	C	Validate integrated pretreatment and enzymatic hydrolysis at demonstration scale		4	IB
M 4.5.7	C	Validate feed flexibility in integrated system			
M 4.6	B	Demonstrate and validate ethanol from 5 biomass sugars	H		BC/IB
M 4.6.1	C	Validate fermentation of all 5 sugars to produce ethanol			
M 4.6.2	C	Optimize ethanol separation			
M 4.6.3	C	Optimize integrated production of ethanol from sugars at pilot scale		3	
M 4.6.4	C	Optimize integrated production of ethanol from sugars at demonstration scale		4	IB

4. Agricultural Residue Processing Pathway - Continued

Milestone #	Type	Sector Biorefinery Pathways/Milestone Titles	Priority (H, M, L)	Stage	Platform
M 4.7	B	Demonstrate and validate chemical building blocks, chemicals or materials from 5 biomass sugars	L		IB
M 4.7.1	C	Optimize chemical building blocks production			
M 4.7.2	C	Optimize high value chemical production			
M 4.7.3	C	Optimize product separation			
M 4.7.4	C	Optimize integrated production of product(s) from sugars at pilot scale		3	
M 4.7.5	C	Optimize integrated production of product(s) from sugars at demonstration scale		4	IB
M 4.8	B	Demonstrate and validate high value chemical and material products from lignin intermediates	L		IB
M 4.8.1	C	Demonstrate high value chemical/material production from lignin			
M 4.8.2	C	Validate product separation			
M 4.8.3	C	Validate integrated production of product(s) from lignin at pilot scale		3	
M 4.8.4	C	Validate integrated production of product(s) from lignin at demonstration scale		4	IB
M 4.9	B	Demonstrate and validate fuel products from lignin intermediates	L		TC/IB
M 4.9.1	C	Demonstrate direct fuel production from lignin			
M 4.9.2	C	Validate fuel product separation			
M 4.9.3	C	Validate integrated production of fuel(s) from lignin at pilot scale		3	
M 4.9.4	C	Validate integrated production of fuels(s) from lignin at demonstration scale		4	IB
M 4.10	B	Demonstrate and validate combined heat and power from lignin intermediates/residues	M		IB
M 4.10.1	C	Demonstrate combined heat and power production from lignin			
M 4.10.2	C	Validate integrated production of heat and power from lignin at pilot scale		3	
M 4.10.3	C	Validate integrated production of heat and power from lignin at demonstration scale		4	IB
M 4.11	B	Demonstrate and validate lignin gasification to produce syngas	H		TC/IB
M 4.11.1	C	Validate feeder system performance			
M 4.11.2	C	Validate gasification performance			
M 4.11.3	C	Validate gas cleanup performance			
M 4.11.4	C	Validate capital costs			
M 4.11.5	C	Validate integrated gasification and gas cleanup at pilot scale		3	
M 4.11.6	C	Validate integrated gasification and gas cleanup at demonstration scale		4	IB
M 4.12	B	Demonstrate and validate biomass gasification to produce syngas	H		TC/IB
M 4.12.1	C	Validate feeder systems to reliably feed solid biomass to high pressure (30 bar) systems			
M 4.12.2	C	Validate gasification performance			
M 4.12.3	C	Validate gas cleanup performance			
M 4.12.4	C	Validate capital costs			
M 4.12.5	C	Validate integrated gasification and gas cleanup at pilot scale		3	
M 4.12.6	C	Validate integrated gasification and gas cleanup at demonstration scale		4	IB
M 4.12.7	C	Validate feed flexibility in integrated system			
M 4.13	B	Demonstrate and validate ethanol from mixed alcohols using lignin or biomass derived syngas	H		TC/IB
M 4.13.1	C	Demonstrate ethanol production from mixed alcohols			
M 4.13.3	C	Validate ethanol separation			
M 4.13.4	C	Validate integrated production of ethanol from syngas at pilot scale		3	
M 4.13.5	C	Validate integrated production of ethanol from syngas at demonstration scale		4	IB
M 4.14	B	Demonstrate and validate hydrogen production from lignin or biomass derived syngas	L		TC/IB
M 4.14.1	C	Demonstrate optimized hydrogen production from syngas			
M 4.14.2	C	Validate hydrogen separation/recovery			
M 4.14.3	C	Validate integrated production of hydrogen from syngas at pilot scale		3	
M 4.14.4	C	Validate integrated production of hydrogen from syngas at demonstration scale		4	IB

4. Agricultural Residue Processing Pathway - Continued

Milestone #	Type	Sector Biorefinery Pathways/Milestone Titles	Priority (H, M, L)	Stage	Platform
M 4.15	B	Demonstrate and validate combined heat and power production from lignin or biomass derived syngas	L		IB
M 4.15.1	C	Demonstrate combined heat and power production from syngas			
M 4.15.2	C	Validate integrated production of heat and power from syngas at pilot scale		3	
M 4.15.3	C	Validate integrated production of heat and power from syngas at demonstration scale		4	IB
M 4.16	B	Demonstrate and validate non-ethanol fuels from lignin or biomass derived syngas	L		TC/IB
M 4.16.1	C	Demonstrate non-ethanol fuel production from lignin or biomass-derived syngas			
M 4.16.2	C	Validate non-ethanol fuel separation			
M 4.16.3	C	Validate integrated production of non-ethanol fuels from syngas at pilot scale		3	
M 4.16.4	C	Validate integrated production of non-ethanol fuels from syngas at demonstration scale		4	IB
M 4.17	B	Demonstrate and validate product(s) from lignin or biomass derived syngas	L		IB
M 4.17.1	C	Demonstrate high value chemical/material production (C3-C5 alcohols) from syngas			
M 4.17.2	C	Validate product(s) separation			
M 4.17.3	C	Validate integrated production of product(s) from syngas at pilot scale		3	
M 4.17.4	C	Validate integrated production of product(s) from syngas at demonstration scale		4	IB
M 4.18	B	Demonstrate and validate non-ethanol fuels from all 5 biomass sugars that are economically viable	L		BC/IB
M 4.18.1	C	Validate fermentation of all 5 sugars to produce non-ethanol fuels			
M 4.18.2	C	Optimize non-ethanol fuel separation			
M 4.18.3	C	Optimize integrated production of non-ethanol fuels from sugars at pilot scale		3	
M 4.18.4	C	Optimize integrated production of non-ethanol fuel from sugars at demonstration scale		4	IB
M 4.19	B	Demonstrate and validate biomass pyrolysis to produce pyrolysis oil intermediate	L		TC/IB
M 4.19.1	C	Validate feeder systems to reliably feed solid biomass to pyrolysis reactor high pressure (30 bar) systems			
M 4.19.2	C	Validate pyrolysis performance			
M 4.19.3	C	Validate pyrolysis oil cleanup performance			
M 4.19.4	C	Validate capital costs - ROI hurdle rate versus cost magnitude hurdle amount			
M 4.19.5	C	Validate integrated pyrolysis and pyrolysis oil cleanup at pilot scale		3	
M 4.19.6	C	Validate integrated pyrolysis and pyrolysis oil cleanup at demonstration scale		4	IB
M 4.19.7	C	Validate feed flexibility in integrated system			
M 4.20	B	Demonstrate and validate fuel production from pyrolysis oil intermediate	L		TC/IB
M 4.20.1	C	Demonstrate fuel production from pyrolysis oil intermediate			
M 4.20.2	C	Validate fuel separation			
M 4.20.3	C	Validate integrated production of fuels from pyrolysis oil at pilot scale		3	
M 4.20.4	C	Validate integrated production of fuels from pyrolysis oil at demonstration scale		4	IB
M 4.21	B	Demonstrate and validate high value chemical and material products from pyrolysis oil intermediates	L		IB
M 4.21.1	C	Demonstrate high value chemical/material production from pyrolysis oil			
M 4.21.2	C	Validate product separation			
M 4.21.3	C	Validate integrated production of product(s) from pyrolysis oil at pilot scale		3	
M 4.21.4	C	Validate integrated production of product(s) from pyrolysis oil at demonstration scale		4	IB
M 4.22	B	Demonstrate and validate combined heat and power from agricultural residues	L		IB
M 4.22.1	C	Validate new CHP process steps at bench scale			
M 4.22.2	C	Validate integrated CHP process at pilot scale		3	
M 4.22.3	C	Validate integrated CHP process at demonstration scale		4	IB

5. Energy Crop Processing Pathway

Overview: Fuel production options for perennial herbaceous energy crops are focused on developing and demonstrating integrated biochemical and thermochemical processes and systems. The mixed sugars from the fractionation process can also be converted to bioproducts (Process Step 5.7); syngas can be converted to products, including heat and power (Process Steps 5.13 and 5.15); and lignin intermediates can be converted to products, including heat and power (Process Steps 5.8 and 5.10).

Milestone #	Type	Sector Biorefinery Pathways/Milestone Titles	Priority (H, M, L)	Stage	Platform
M 5	A	Complete systems level demonstration and validation of all key technologies to utilize perennial crops in existing or new facilities			
M 5.1	B	Demonstrate and validate integrated switchgrass production and harvesting logistics	H	4	F/IB
M 5.1.1	C	Demonstrate sustainable switchgrass agronomic practices			
M 5.1.2	C	Demonstrate wet and dry switchgrass harvesting			
M 5.1.3	C	Demonstrate wet and dry switchgrass storage			
M 5.1.4	C	Demonstrate wet and dry switchgrass transportation			
M 5.1.5	C	Demonstrate quality and quantity of switchgrass available			
M 5.1.6	C	Demonstrate switchgrass preprocessing benefits			
M 5.1.7	C	Validate integrated switchgrass logistics at pilot scale		3	
M 5.1.8	C	Validate integrated switchgrass logistics at demonstration scale		4	IB
M 5.2	B	Demonstrate and validate integrated woody crop harvesting logistics	M		F/IB
M 5.2.1	C	Demonstrate sustainable woody crop agronomic practices			
M 5.2.2	C	Demonstrate woody crop harvesting			
M 5.2.3	C	Demonstrate woody crop storage			
M 5.2.4	C	Demonstrate woody crop transportation			
M 5.2.5	C	Demonstrate quality and quantity of woody crops available			
M 5.2.6	C	Demonstrate woody crop preprocessing benefits			
M 5.2.7	C	Validate integrated woody crop logistics at pilot scale		3	
M 5.2.8	C	Validate integrated woody crop logistics at demonstration scale		4	IB
M 5.3	B	Feedstock Flexibility and Availability via Blending Depot or Elevator	L		F
M 5.3.1	C	To be determined			
M 5.4	B	Demonstrate and validate switchgrass fractionation to produce mixed biomass sugars	H		BC/IB
M 5.4.1	C	Validate cellulase enzyme cost			
M 5.4.2	C	Validate pretreatment technology cost			
M 5.4.3	C	Demonstrate ability to economically satisfy internal heat and power demands			
M 5.4.4	C	Validate capital cost			
M 5.4.5	C	Validate integrated pretreatment and enzymatic hydrolysis at pilot scale		3	
M 5.4.6	C	Validate integrated pretreatment and enzymatic hydrolysis at demonstration scale		4	IB
M 5.4.7	C	Validate feed flexibility in integrated system			
M 5.5	B	Demonstrate and validate woody crop fractionation to produce mixed, dilute biomass sugars	M		BC/IB
M 5.5.1	C	Validate cellulase enzyme cost			
M 5.5.2	C	Validate pretreatment technology cost			
M 5.5.3	C	Demonstrate ability to economically satisfy internal heat and power demands			
M 5.5.4	C	Validate capital cost			
M 5.5.5	C	Validate integrated pretreatment and enzymatic hydrolysis at pilot scale		3	
M 5.5.6	C	Validate integrated pretreatment and enzymatic hydrolysis at demonstration scale		4	IB
M 5.5.7	C	Validate feed flexibility in integrated system			
M 5.6	B	Demonstrate and validate ethanol from 5 biomass sugars	H		BC/IB
M 5.6.1	C	Validate ethanol production			
M 5.6.2	C	Validate ethanol separation/recovery			
M 5.6.3	C	Validate integrated production of product(s) from sugars at pilot scale			
M 5.6.4	C	Validate integrated production of product(s) from sugars at demonstration scale			IB

5. Energy Crop Processing Pathway - Continued

Milestone #	Type	Sector Biorefinery Pathways/Milestone Titles	Priority (H, M, L)	Stage	Platform
M 5.7	B	Demonstrate and validate products from 5 biomass sugars	L		IB
M 5.7.1	C	Validate chemical building blocks production			
M 5.7.2	C	Validate high value chemical production			
M 5.7.3	C	Validate product separation			
M 5.7.4	C	Validate integrated production of product(s)from sugars at pilot scale		3	
M 5.7.5	C	Validate integrated production of product(s)from sugars at demonstration scale		4	IB
M 5.8	B	Demonstrate and validate high value chemical and material products from lignin intermediates	L		IB
M 5.8.1	C	Demonstrate high value chemical/material production from lignin			
M 5.8.2	C	Validate product separation			
M 5.8.3	C	Validate integrated production of product(s)from lignin at pilot scale		3	
M 5.8.4	C	Validate integrated production of product(s)from lignin at demonstration scale		4	IB
M 5.9	B	Demonstrate and validate fuel products from lignin intermediates	L		TC/IB
M 5.9.1	C	Demonstrate direct fuel production from lignin			
M 5.9.2	C	Validate fuel product separation			
M 5.9.3	C	Validate integrated production of fuel(s)from lignin at pilot scale		3	
M 5.9.4	C	Validate integrated production of fuels(s)from lignin at demonstration scale		4	IB
M 5.10	B	Demonstrate and validate combined heat and power from lignin intermediates/residues	M		IB
M 5.10.1	C	Demonstrate combined heat and power production from lignin			
M 5.10.2	C	Validate integrated production of heat and power from lignin at pilot scale		3	
M 5.10.3	C	Validate integrated production of heat and power from lignin at demonstration scale		4	IB
M 5.11	B	Demonstrate and validate lignin gasification to produce syngas	H		TC/IB
M 5.11.1	C	Validate feeder system performance			
M 5.11.2	C	Validate gasification performance			
M 5.11.3	C	Validate gas cleanup performance			
M 5.11.4	C	Validate capital costs - ROI hurdle rate versus cost magnitude hurdle amount			
M 5.11.5	C	Validate integrated gasification and gas cleanup at pilot scale		3	
M 5.11.6	C	Validate integrated gasification and gas cleanup at demonstration scale		4	IB
M 5.12	B	Demonstrate and validate biomass gasification to produce syngas	H		TC/IB
M 5.12.1	C	Validate feeder systems to reliably feed solid biomass to high pressure (30 bar) systems			
M 5.12.2	C	Validate gasification performance			
M 5.12.3	C	Validate gas cleanup performance			
M 5.12.4	C	Validate capital costs			
M 5.12.5	C	Validate integrated gasification and gas cleanup at pilot scale		3	
M 5.12.6	C	Validate integrated gasification and gas cleanupat demonstration scale		4	IB
M 5.12.7	C	Validate feed flexibility in integrated system			
M 5.13	B	Demonstrate and validate ethanol from mixed alcohols using lignin or biomass derived syngas	H		TC/IB
M 5.13.1	C	Demonstrate ethanol production from mixed alcohols			
M 5.13.3	C	Validate ethanol separation			
M 5.13.4	C	Validate integrated production of ethanol from syngas at pilot scale		3	
M 5.13.5	C	Validate integrated production of ethanol from syngas at demonstration scale		4	IB
M 5.14	B	Demonstrate and validate hydrogen production from lignin or biomass derived syngas	L		TC/IB
M 5.14.1	C	Demonstrate optimized hydrogen production from syngas			
M 5.14.2	C	Validate hydrogen separation/recovery			
M 5.14.3	C	Validate integrated production of hydrogen from syngas at pilot scale		3	
M 5.14.4	C	Validate integrated production of hydrogen from syngas at demonstration scale		4	IB

5. Energy Crop Processing Pathway - Continued

Milestone #	Type	Sector Biorefinery Pathways/Milestone Titles	Priority (H, M, L)	Stage	Platform
M 5.15	B	Demonstrate and validate combined heat and power production from lignin or biomass derived syngas	L		IB
M 5.15.1	C	Demonstrate combined heat and power production from syngas			
M 5.15.2	C	Validate integrated production of heat and power from syngas at pilot scale		3	
M 5.15.3	C	Validate integrated production of heat and power from syngas at demonstration scale		4	IB
M 5.16	B	Demonstrate and validate non-ethanol fuels from lignin or biomass derived syngas	L		TC/IB
M 5.16.1	C	Demonstrate non-ethanol fuel production from lignin or biomass-derived syngas	L		
M 5.16.2	C	Validate non-ethanol fuel separation	L		
M 5.16.3	C	Validate integrated production of non-ethanol fuels from syngas at pilot scale	L	3	
M 5.16.4	C	Validate integrated production of non-ethanol fuels from syngas at demonstration scale	L	4	IB
M 5.17	B	Demonstrate and validate product(s) from lignin or biomass derived syngas	L		IB
M 5.17.1	C	Demonstrate high value chemical/material production (C3-C5 alcohols) from syngas	L		
M 5.17.2	C	Validate product(s) separation	L		
M 5.17.3	C	Validate integrated production of product(s) from syngas at pilot scale	L	3	
M 5.17.4	C	Validate integrated production of product(s) from syngas at demonstration scale	L	4	IB
M 5.18	B	Demonstrate and validate non-ethanol fuels from 5 biomass sugars that are economically viable	L		BC/IB
M 5.18.1	C	Validate fermentation of all 5 sugars to produce non-ethanol fuels	L		
M 5.18.2	C	Optimize non-ethanol fuel separation	L		
M 5.18.3	C	Optimize integrated production of non-ethanol fuels from sugars at pilot scale	L	3	
M 5.18.4	C	Optimize integrated production of non-ethanol fuel from sugars at demonstration scale	L	4	IB
M 5.19	B	Demonstrate and validate biomass pyrolysis to produce pyrolysis oil intermediate	L		TC/IB
M 5.19.1	C	Validate feeder systems to reliably feed solid biomass to pyrolysis reactor high pressure (30 bar) systems			
M 5.19.2	C	Validate pyrolysis performance			
M 5.19.3	C	Validate pyrolysis oil cleanup performance			
M 5.19.4	C	Validate capital costs - ROI hurdle rate versus cost magnitude hurdle amount			
M 5.19.5	C	Validate integrated pyrolysis and pyrolysis oil cleanup at pilot scale		3	
M 5.19.6	C	Validate integrated pyrolysis and pyrolysis oil cleanup at demonstration scale		4	IB
M 5.19.7	C	Validate feed flexibility in integrated system			
M 5.20	B	Demonstrate and validate fuels from pyrolysis oil intermediate	L		TC/IB
M 5.20.1	C	Demonstrate fuel production from pyrolysis oil intermediate	L		
M 5.20.2	C	Validate fuel separation	L		
M 5.20.3	C	Validate integrated production of fuels from pyrolysis oil at pilot scale	L	3	
M 5.20.4	C	Validate integrated production of fuels from pyrolysis oil at demonstration scale	L	4	IB
M 5.21	B	Demonstrate and validate high value chemical and material products from pyrolysis oil intermediates	L		IB
M 5.21.1	C	Demonstrate high value chemical/material production from pyrolysis oil	L		
M 5.21.2	C	Validate product separation	L		
M 5.21.3	C	Validate integrated production of product(s) from pyrolysis oil at pilot scale	L	3	
M 5.21.4	C	Validate integrated production of product(s) from pyrolysis oil at demonstration scale	L	4	IB
M 5.22	B	Demonstrate and validate combined heat and power from energy crops	L		IB
M 5.22.1	C	Validate new CHP process steps at bench scale			
M 5.22.2	C	Validate integrated CHP process at pilot scale		3	
M 5.22.3	C	Validate integrated CHP process at demonstration scale		4	IB

5. Energy Crop Processing Pathway - Continued

Milestone #	Type	Sector Biorefinery Pathways/Milestone Titles	Priority (H, M, L)	Stage	Platform
M 5.23	B	Demonstrate and validate integrated annual energy crop harvesting logistics	M		F/IB
M 5.23.1	C	Demonstrate sustainable annual energy crop agronomic practices			
M 5.23.2	C	Demonstrate annual energy crop harvesting			
M 5.23.3	C	Demonstrate annual energy crop storage			
M 5.23.4	C	Demonstrate annual energy crop transportation			
M 5.23.5	C	Demonstrate quality and quantity of annual energy crops available			
M 5.23.6	C	Demonstrate annual energy crop preprocessing benefits			
M 5.23.7	C	Validate integrated annual energy crop logistics at pilot scale		3	
M 5.23.8	C	Validate integrated annual energy crop logistics at demonstration scale		4	IB
M 5.24	B	Demonstrate and validate annual energy crop fractionation to produce mixed biomass sugars	H		BC/IB
M 5.24.1	C	Validate cellulase enzyme cost			
M 5.24.2	C	Validate pretreatment technology cost			
M 5.24.3	C	Demonstrate ability to economically satisfy internal heat and power demands			
M 5.24.4	C	Validate capital cost			
M 5.24.5	C	Validate integrated pretreatment and enzymatic hydrolysis at pilot scale		3	
M 5.24.6	C	Validate integrated pretreatment and enzymatic hydrolysis at demonstration scale		4	IB
M 5.24.7	C	Validate feed flexibility in integrated system			

6. Forest Resources Processing Pathway

Overview: The Forest Resources Processing Pathway is a consolidation of the Pulp and Paper Mill Improvements Pathway and the Forest Products Mill Improvements Pathway described in the previous version of the MYPP, with the added scope of logging and fuel treatment residues as well as un-utilized pulp wood. The objectives of this pathway include the development and demonstration of the conversion of forest resources to biofuel, as well as an improvement in the economic efficiency of existing pulp and paper mills. One consideration may be the conversion of underperforming existing pulp and paper mills into plants that produce biofuels.

Milestone #	Type	Sector Biorefinery Pathways/Milestone Titles	Priority (H, M, L)	Stage	Platform
M 6	A	Complete systems level demonstration and validation of technologies to improve pulp and paper mill facilities and/or produce additional products (fuels, chemicals and /or power) from wood feedstock in a pulp and paper mill environment			
M 6.1	B	Demonstrate and validate integrated logging residue and forest thinnings collection and logistics	H		F/IB
M 6.1.1	C	Demonstrate sustainable logging practices			
M 6.1.2	C	Demonstrate logging residue collection			
M 6.1.3	C	Demonstrate forest thinnings collection			
M 6.1.4	C	Demonstrate logging residue and forest thinnings transportation			
M 6.1.5	C	Demonstrate quality and quantity of logging residue and forest thinnings available			
M 6.1.6	C	Demonstrate logging residue and forest thinnings preprocessing benefits			
M 6.1.7	C	Validate integrated logging residue and forest thinnings logistics at pilot scale		3	
M 6.1.8	C	Validate integrated logging residue and forest thinnings logistics at demonstration scale		4	IB
M 6.2	B	Demonstrate and validate integrated fuel treatment biomass collection and logistics	L		F/IB
M 6.2.1	C	Demonstrate fuel treatment biomass collection			
M 6.2.2	C	Demonstrate fuel treatment biomass storage			
M 6.2.3	C	Demonstrate fuel treatment biomass transportation			
M 6.2.4	C	Demonstrate fuel treatment biomass quality and quantity of available			
M 6.2.5	C	Demonstrate fuel treatment biomass preprocessing benefits			
M 6.2.6	C	Validate integrated fuel treatment biomass logistics at pilot scale		3	
M 6.2.7	C	Validate integrated fuel treatment biomass logistics at demonstration scale		4	IB
M 6.3	B	Demonstrate and validate forest resources fractionation to produce mixed, dilute biomass sugars	H		BC/IB
M 6.3.1	C	Validate cellulase enzyme cost			
M 6.3.2	C	Validate pretreatment technology cost			
M 6.3.3	C	Demonstrate ability to economically satisfy internal heat and power demands			
M 6.3.4	C	Validate capital cost			
M 6.3.5	C	Validate integrated pretreatment and enzymatic hydrolysis at pilot scale		3	
M 6.3.6	C	Validate integrated pretreatment and enzymatic hydrolysis at demonstration scale		4	IB
M 6.3.7	C	Validate feed flexibility in integrated system			
M 6.4	B	Demonstrate and validate ethanol from 5 biomass sugars	H		BC/IB
M 6.4.1	C	Validate fermentation of all 5 sugars to produce ethanol			
M 6.4.2	C	Optimize ethanol separation			
M 6.4.3	C	Optimize integrated production of ethanol from sugars at pilot scale		3	
M 6.4.4	C	Optimize integrated production of ethanol from sugars at demonstration scale		4	IB
M 6.5	B	Demonstrate and validate non-ethanol fuels from 5 biomass sugars	H		BC/IB
M 6.5.1	C	Validate fermentation of all 5 sugars to produce non-ethanol fuels			
M 6.5.2	C	Optimize fuel separation			
M 6.5.3	C	Optimize integrated production of non-ethanol fuels from sugars at pilot scale		3	
M 6.5.4	C	Optimize integrated production of non-ethanol fuels from sugars at demonstration scale		4	IB

6. Forest Resources Processing Pathway - Continued

Milestone #	Type	Sector Biorefinery Pathways/Milestone Titles	Priority (H, M, L)	Stage	Platform
M 6.6	B	Demonstrate and validate chemical building blocks, chemicals or materials from 5 biomass sugars	L		IB
M 6.6.1	C	Optimize chemical building blocks production			
M 6.6.2	C	Optimize high value chemical production			
M 6.6.3	C	Optimize product separation			
M 6.6.4	C	Optimize integrated production of product(s) from sugars at pilot scale		3	
M 6.6.5	C	Optimize integrated production of product(s) from sugars at demonstration scale		4	IB
M 6.7	B	Demonstrate and validate fuel products from lignin intermediates	L		TC/IB
M 6.7.1	C	Demonstrate direct fuel production from lignin			
M 6.7.2	C	Validate fuel product separation			
M 6.7.3	C	Validate integrated production of fuel(s) from lignin at pilot scale		3	
M 6.7.4	C	Validate integrated production of fuels(s) from lignin at demonstration scale		4	IB
M 6.8	B	Demonstrate and validate high value chemical and material products from lignin intermediates	L		IB
M 6.8.1	C	Demonstrate high value chemical/material production from lignin			
M 6.8.2	C	Validate product separation			
M 6.8.3	C	Validate integrated production of product(s) from lignin at pilot scale		3	
M 6.8.4	C	Validate integrated production of product(s) from lignin at demonstration scale		4	IB
M 6.9	B	Demonstrate and validate combined heat and power from lignin intermediates/residues	M		IB
M 6.9.1	C	Demonstrate combined heat and power production from lignin			
M 6.9.2	C	Validate integrated production of heat and power from lignin at pilot scale		3	
M 6.9.3	C	Validate integrated production of heat and power from lignin at demonstration scale		4	IB
M 6.10	B	Demonstrate and validate lignin gasification to produce syngas	H		TC/IB
M 6.10.1	C	Validate feeder system performance			
M 6.10.2	C	Validate gasification performance			
M 6.10.3	C	Validate gas cleanup performance			
M 6.10.4	C	Validate capital cost			
M 6.10.5	C	Validate integrated gasification and gas cleanup at pilot scale		3	
M 6.10.6	C	Validate integrated gasification and gas cleanup at demonstration scale		4	IB
M 6.11	B	Demonstrate and validate cost-effective biomass gasification of wood, forest residues and other process residues and synthesis gas cleanup in a forest resources mill environment	L		TC/IB
M 6.11.1	C	Develop cost effective gasification designs for syngas production at appropriate scale			
M 6.11.2	C	Validate feeder system performance to reliably feed solids to high pressure (30 bar) systems)			
M 6.11.3	C	Validate gasification performance			
M 6.11.4	C	Validate cost-effective gas cleanup performance			
M 6.11.5	C	Validate integrated biomass gasification and syngas cleanup process at pilot scale		3	
M 6.11.6	C	Validate integrated biomass gasification and syngas cleanup process in a forest resources mill environment		4	IB
		Validate feed flexibility in integrated system			
M 6.12	B	Demonstrate and validate production of ethanol from syngas in a forest resources mill environment	L		TC/IB
M 6.12.1	C	Produce mixed alcohols from syngas			
M 6.12.2	C	Recover ethanol fuel product			
M 6.12.3	C	Validate integrated process at pilot scale		3	
M 6.12.4	C	Validate new process in a forest resources mill environment		4	IB
M 6.13	B	Demonstrate and validate production of non-ethanol fuels from syngas in a forest resources mill environment	L		TC/IB
M 6.13.1	C	Produce non-ethanol fuel from biomass syngas			
M 6.13.2	C	Recover fuel product			
M 6.13.3	C	Validate integrated process at pilot scale		3	
M 6.13.4	C	Validate new process in a forest resources mill environment		4	IB

6. Forest Resources Processing Pathway - Continued

Milestone #	Type	Sector Biorefinery Pathways/Milestone Titles	Priority (H, M, L)	Stage	Platform
M 6.14	B	Demonstrate and validate hydrogen production from lignin or biomass derived syngas in a forest resources mill environment	L		TC/IB
M 6.14.1	C	Demonstrate optimized hydrogen production from syngas			
M 6.14.2	C	Validate hydrogen separation/recovery			
M 6.14.3	C	Validate integrated production of hydrogen from syngas at pilot scale		3	
M 6.14.4	C	Validate integrated production of hydrogen from syngas at demonstration scale		4	IB
M 6.15	B	Demonstrate and validate product(s) production from lignin or biomass derived syngas in a forest resources mill environment	L		IB
M 6.15.1	C	Demonstrate high value chemical/material production from syngas			
M 6.15.2	C	Validate product(s) separation			
M 6.15.3	C	Validate integrated production of product(s) from syngas at pilot scale		3	
M 6.15.4	C	Validate integrated production of product(s) from syngas at demonstration scale		4	IB
M 6.16	B	Demonstrate and validate syngas utilization for combined heat and power in a forest resources mill environment	L		IB
M 6.16.1	C	Verify fuel gas quality to levels necessary for CHP or clean cold gas consuming equipment			
M 6.16.2	C	Validate CHP from syngas and/or direct use of syngas in process equipment			
M 6.16.3	C	Validate integrated process at pilot scale		3	
M 6.16.4	C	Validate new process in a forest resources mill environment		4	IB
M 6.17	B	Demonstrate and validate bio-oil production to a stable intermediate forest resources mill environment	L		TC/IB
M 6.17.1	C	Validate bio-oil production			
M 6.17.2	C	Validate bio-oil intermediate recovery			
M 6.17.3	C	Validate integrated process for producing bio-oil at pilot scale		3	
M 6.17.4	C	Demonstrate and validate new process in a forest resources mill environment		4	IB
M 6.17.5	C	Validate feed flexibility in integrated system			
M 6.18	B	Achieve cost-effective conversion bio-oil intermediate into fuel(s) in a forest resources mill environment	L		TC/IB
M 6.18.1	C	Validate production of fuels from bio-oil			
M 6.18.2	C	Validate bio-oil fuel(s) recovery			
M 6.18.3	C	Validate integrated process for producing bio-oil based fuel at pilot scale		3	
M 6.18.4	C	Validate integrated process in a forest resources mill environment		4	IB
M 6.19	B	Achieve cost-effective conversion bio-oil intermediate into product(s) in a forest resources mill environment	L		IB
M 6.19.1	C	Validate production of products from bio-oil			
M 6.19.2	C	Validate bio-oil product(s) recovery			
M 6.19.3	C	Validate integrated process for producing bio-oil product at pilot scale		3	
M 6.19.4	C	Validate integrated process in a forest resources mill environment		4	IB
M 6.20	B	Demonstrate and validate cost-effective extraction of C5 and C6 sugars from hemicellulose upstream of the pulp digester in a pulp mill without negatively impacting paper quality	L		BC/IB
M 6.20.1	C	Meet yield target for C5 and C6 sugars without negatively impacting paper quality			
M 6.20.2	C	Meet sugar upgrading requirements			
M 6.20.3	C	Meet targets for recovery of other intermediates			
M 6.20.4	C	Validate integrated sugar extraction process at pilot scale		3	
M 6.20.5	C	Validate sugar extraction process in pulp and paper mill		4	IB
M 6.21	B	Demonstrate and validate reliable and economic gasification of spent pulping liquor, recycle liquor causticization, chemical recovery and gas cleanup in a pulp mill	L		TC/IB
M 6.21.1	C	Validate reliable and economic performance of gasification of spent pulping liquor			
M 6.21.2	C	Validate cost effective causticization and return Na based pulping chemicals			
M 6.21.3	C	Validate advantages of co-gasification of spent pulping liquors and other forms of biomass (woody, recycle paper streams, and bio-oil)			
M 6.21.4	C	Validate process chemical recovery from spent pulping liquor syngas			
M 6.21.5	C	Validate gas cleanup technologies on spent pulping liquor syngas			
M 6.21.6	C	Validate integrated black liquor gasification, causticization, chemical recovery and gas cleanup process at pilot scale		3	
M 6.21.7	C	Validate integrated black liquor gasification, causticization, chemical recovery and gas cleanup process in pulp and paper mill		4	IB

Program Biorefinery Pathways Framework

7. Waste Processing Pathway					
Overview: This is a new pathway added to the OBP portfolio based on the quantity and near term availability of cellulosic wastes for biofuels production. The objective is to develop and demonstrate new commercially viable processes to convert the cellulosic fractions of existing waste streams to biofuels. Feedstocks include food processing waste, municipal solid waste, urban wood waste, and construction and demolition wastes.					
Milestone #	Type	Sector Biorefinery Pathways/Milestone Titles	Priority (H, M, L)	Stage	Platform
7	A	Complete systems level demonstration and validation of technologies to process waste biomass streams to produce fuels, chemicals and /or power.			
M 7.1	B	Demonstrate and validate fractionation of carbohydrate rich waste streams to produce mixed, dilute biomass sugars	H		BC/IB
M 7.1.1	C	Validate cellulase enzyme cost			
M 7.1.2	C	Validate pretreatment technology cost			
M 7.1.3	C	Demonstrate ability to economically satisfy internal heat and power demands			
M 7.1.4	C	Validate capital cost			
M 7.1.5	C	Validate integrated pretreatment and enzymatic hydrolysis at pilot scale		3	
M 7.1.6	C	Validate integrated pretreatment and enzymatic hydrolysis at demonstration scale		4	IB
M 7.1.7	C	Validate feed flexibility in integrated system			
M 7.2	B	Demonstrate and validate ethanol from 5 biomass sugars	H		BC/IB
M 7.2.1	C	Validate fermentation of all 5 sugars to produce ethanol			
M 7.2.2	C	Optimize ethanol separation			
M 7.2.3	C	Optimize integrated production of ethanol from sugars at pilot scale		3	
M 7.2.4	C	Optimize integrated production of ethanol from sugars at demonstration scale		4	IB
M 7.3	B	Demonstrate and validate non-ethanol fuels from 5 biomass sugars	L		BC/IB
M 7.3.1	C	Validate fermentation of all 5 sugars to produce non-ethanol fuels			
M 7.3.2	C	Optimize non-ethanol fuel separation			
M 7.3.3	C	Optimize integrated production of non-ethanol fuels from sugars at pilot scale		3	
M 7.3.4	C	Optimize integrated production of non-ethanol fuel from sugars at demonstration scale		4	IB
M 7.4	B	Demonstrate and validate chemical building blocks, chemicals or materials from 5 biomass sugars	L		IB
M 7.4.1	C	Optimize chemical building blocks production			
M 7.4.2	C	Optimize high value chemical production			
M 7.4.3	C	Optimize product separation			
M 7.4.4	C	Optimize integrated production of product(s)from sugars at pilot scale		3	
M 7.4.5	C	Optimize integrated production of product(s)from sugars at demonstration scale		4	IB
M 7.6	B	Demonstrate and validate high value chemical and material products from lignin intermediates	L		IB
M 7.6.1	C	Demonstrate high value chemical/material production from lignin			
M 7.6.2	C	Validate product separation			
M 7.6.3	C	Validate integrated production of product(s)from lignin at pilot scale		3	
M 7.6.4	C	Validate integrated production of product(s)from lignin at demonstration scale		4	IB
M 7.5	B	Demonstrate and validate fuel products from lignin intermediates	L		TC/IB
M 7.5.1	C	Demonstrate direct fuel production from lignin			
M 7.5.2	C	Validate fuel product separation			
M 7.5.3	C	Validate integrated production of fuel(s)from lignin at pilot scale			
M 7.5.4	C	Validate integrated production of fuels(s)from lignin at demonstration scale			IB
M 7.7	B	Demonstrate and validate combined heat and power from lignin intermediates/residues	M		IB
M 7.7.1	C	Demonstrate combined heat and power production from lignin			
M 7.7.2	C	Validate integrated production of heat and power from lignin at pilot scale		3	
M 7.7.3	C	Validate integrated production of heat and power from lignin at demonstration scale		4	IB
M 7.8	B	Demonstrate and validate lignin gasification to produce syngas	M		TC/IB
M 7.8.1	C	Validate feeder system performance			
M 7.8.2	C	Validate gasification performance			
M 7.8.3	C	Validate gas cleanup performance			
M 7.8.4	C	Validate capital costs			
M 7.8.5	C	Validate integrated gasification and gas cleanup at pilot scale		3	
M 7.8.6	C	Validate integrated gasification and gas cleanupat demonstration scale		4	IB

7. Waste Processing Pathway - Continued

Milestone #	Type	Sector Biorefinery Pathways/Milestone Titles	Priority (H, M, L)	Stage	Platform
M 7.9	B	Demonstrate and validate waste biomass gasification to produce syngas	H		TC/IB
M 7.9.1	C	Validate feeder systems to reliably feed solid biomass to high pressure (30 bar) systems			
M 7.9.2	C	Validate gasification performance			
M 7.9.3	C	Validate gas cleanup performance			
M 7.9.4	C	Validate capital costs			
M 7.9.5	C	Validate integrated gasification and gas cleanup at pilot scale		3	
M 7.9.6	C	Validate integrated gasification and gas cleanup at demonstration scale		4	IB
M 7.9.7	C	Validate feed flexibility in integrated system			
M 7.10	B	Demonstrate and validate ethanol from mixed alcohols using lignin or waste biomass derived syngas	H		TC/IB
M 7.10.1	C	Demonstrate ethanol production from mixed alcohols			
M 7.10.3	C	Validate ethanol separation			
M 7.10.4	C	Validate integrated production of ethanol from syngas at pilot scale		3	
M 7.10.5	C	Validate integrated production of ethanol from syngas at demonstration scale		4	IB
M 7.11	B	Demonstrate and validate non-ethanol fuels from lignin or waste biomass derived syngas	L		TC/IB
M 7.11.1	C	Demonstrate non-ethanol fuel production from lignin or biomass-derived syngas			
M 7.11.2	C	Validate non-ethanol fuel separation			
M 7.11.3	C	Validate integrated production of non-ethanol fuels from syngas at pilot scale		3	
M 7.11.4	C	Validate integrated production of non-ethanol fuels from syngas at demonstration scale		4	IB
M 7.12	B	Demonstrate and validate hydrogen production from lignin or waste biomass derived syngas	L		TC/IB
M 7.12.1	C	Demonstrate optimized hydrogen production from syngas			
M 7.12.2	C	Validate hydrogen separation/recovery			
M 7.12.3	C	Validate integrated production of hydrogen from syngas at pilot scale		3	
M 7.12.4	C	Validate integrated production of hydrogen from syngas at demonstration scale		4	IB
M 7.13	B	Demonstrate and validate product(s) from lignin or waste biomass derived syngas	L		IB
M 7.13.1	C	Demonstrate high value chemical/material production from syngas			
M 7.13.2	C	Validate product(s) separation			
M 7.13.3	C	Validate integrated production of product(s) from syngas at pilot scale		3	
M 7.13.4	C	Validate integrated production of product(s) from syngas at demonstration scale		4	IB
M 7.14	B	Demonstrate and validate combined heat and power production from lignin or waste biomass derived syngas	L		IB
M 7.14.1	C	Demonstrate combined heat and power production from syngas			
M 7.14.2	C	Validate integrated production of heat and power from syngas at pilot scale		3	
M 7.14.3	C	Validate integrated production of heat and power from syngas at demonstration scale		4	IB
M 7.15	B	Demonstrate and validate waste biomass pyrolysis to produce pyrolysis oil intermediate	L		TC/IB
M 7.15.1	C	Validate feeder systems to reliably feed solid biomass to pyrolysis reactor high pressure (30 bar) systems			
M 7.15.2	C	Validate pyrolysis performance			
M 7.15.3	C	Validate pyrolysis oil cleanup performance			
M 7.15.4	C	Validate capital costs			
M 7.15.5	C	Validate integrated pyrolysis and pyrolysis oil cleanup at pilot scale		3	
M 7.15.6	C	Validate integrated pyrolysis and pyrolysis oil cleanup at demonstration scale		4	IB
M 7.15.7	C	Validate feed flexibility in integrated system			
M 7.16	B	Demonstrate and validate fuels from pyrolysis oil intermediate	L		TC/IB
M 7.16.1	C	Demonstrate fuel production from pyrolysis oil intermediate			
M 7.16.2	C	Validate fuel separation			
M 7.16.3	C	Validate integrated production of fuels from pyrolysis oil at pilot scale		3	
M 7.16.4	C	Validate integrated production of fuels from pyrolysis oil at demonstration scale		4	IB
M 7.17	B	Demonstrate and validate high value chemical and material products from pyrolysis oil intermediates	L		IB
M 7.17.1	C	Demonstrate high value chemical/material production from pyrolysis oil			
M 7.17.2	C	Validate product separation			
M 7.17.3	C	Validate integrated production of product(s) from pyrolysis oil at pilot scale		3	
M 7.17.4	C	Validate integrated production of product(s) from pyrolysis oil at demonstration scale		4	IB

APPENDIX B: TECHNICAL TARGET TABLES

Table B-1: Technical Targets for Biomass Feedstock Production

Processing Area Cost Contributions & Key Technical Parameters	Metric	Corn Stover			Cereal Straw			Switchgrass		
		2007	2012	2017	2007	2012	2017	2007	2012	2017
Process Concept: Herbaceous Biomass Production, Standing in Field										
Year \$ basis		2007	2007	2007	2007	2007	2007	2007	2007	2007
Grower Payment	\$/dry ton	\$13.10	\$13.10	\$26.20	\$13.10	\$13.10	\$26.20	\$13.10	\$13.10	\$26.20
Tonnage Potential at or below Grower Payment	millions of dry tons/yr	1.4	58.0	96.6	12.8	19.7	19.7	0	10.9	52.0
Percent Dry Feedstock (<15% moisture)	%	100	4	2	100	100	100	0	60	29
Agronomic & Environmental Practice Factors	millions of dry tons/yr	-	13.0	51.6	-	8.0	8.0	-	10.9	52.0
New Crop Development Factors	millions of dry tons/yr	-	-	-	-	-	-	-	-	-
Feedstock Production Case Reference	Threshold Cost-Tonnage Analysis 09-04-06									

Processing Area Cost Contributions & Key Technical Parameters	Metric	National Forest Resources			Other Woody Public Resources			Woody Private Resources		
		2007	2012	2017	2007	2012	2017	2007	2012	2017
Process Concept: Woody Biomass Production, Standing in Field or Forest										
Year \$ basis		2007	2007	2007	2007	2007	2007	2007	2007	2007
Stumpage Fee	\$/dry ton	\$13.10	\$13.10	\$26.20	\$13.10	\$13.10	\$26.20	\$13.10	\$13.10	\$26.20
Tonnage Potential at or below Stumpage Fee	millions of dry tons/yr	0.0	1.1	10.0	0.0	2.7	7.0	0.0	37.2	65.0
Percent Dry Feedstock (<15% moisture)	%	0	0	0	0	0	0	0	0	0
Agronomic & Environmental Practice Factors	millions of dry tons/yr	-	-	-	-	-	-	-	2.0	7.6
New Crop Development Factors	millions of dry tons/yr	-	-	-	-	0.1	0.5	-	-	-
Feedstock Production Case Reference	Threshold Cost-Tonnage Analysis 09-04-06									

Table B-2. Technical Targets for Dry Herbaceous Biomass Feedstock Collection, Preprocessing and Delivery to Conversion Reactor Inlet

Processing Area Cost Contributions & Key Technical Parameters	Metric	Dry Herbaceous			
		2007	2009	2012	2017
Process Concept: Feedstock Collection, Preprocessing and Delivery to Conversion Reactor Inlet					
Year \$ basis		2007	2007	2007	2007
Total Cost of Feedstock Logistics	\$/dry ton (without quality credit)	\$47.00	\$32.80	\$32.80	\$32.80
Overall Logistics Efficiency (output/input)	% (dry matter basis)	95	95	95	95
Harvest and Collection					
Total Cost Contribution	\$/dry ton	\$18.40	\$10.60	\$10.60	\$10.60
Capital Cost Contribution	\$/dry ton	\$7.80	\$4.70	\$4.70	\$4.70
Operating Cost Contribution	\$/dry ton	\$10.60	\$5.90	\$5.90	\$5.90
Collection Efficiency	% improvement over baseline	25	40	40	40
Single-Pass Capacity	dry tons/hr	-	-	-	-
Selective Harvest Feedstock Quality	change in \$/dry ton	-	-	-	\$1.50
Storage and Queuing					
Total Cost Contribution	\$/dry ton	\$6.10	\$3.70	\$3.70	\$3.70
Capital Cost Contribution	\$/dry ton	\$0.20	\$0.10	\$0.10	\$0.10
Operating Cost Contribution	\$/dry ton	\$5.90	\$3.60	\$3.60	\$3.60
Shrinkage	% dry matter loss	<5	<5	<5	<5
Storage Quality	change in \$/dry ton	-	-	-	-
Preprocessing					
Total Cost Contribution	\$/dry ton	\$7.80	\$6.20	\$6.20	\$6.20
Capital Cost Contribution	\$/dry ton	\$1.50	\$1.20	\$1.20	\$1.20
Operating Cost Contribution	\$/dry ton	\$6.30	\$5.00	\$5.00	\$5.00
Capacity	dry tons/kW-hr	0.034	0.043	0.043	0.043
Bulk Density	dry lbs/cu-ft	12	14	14	14
Preprocessing Quality	change in \$/dry ton	-	-	-	\$3.00
Transportation and Handling					
Total Cost Contribution	\$/dry ton	\$14.70	\$12.30	\$12.30	\$12.30
Capital Cost Contribution	\$/dry ton	\$3.10	\$2.70	\$2.70	\$2.70
Operating Cost Contribution	\$/dry ton	\$11.60	\$9.60	\$9.60	\$9.60
Plant Conveying Bulk Density	dry lbs/cu-ft	4.4	9	9	9
Plant Storage Bulk Density	dry lbs/cu-ft	10	12	12	12
Field Bulk Density	dry lbs/cu-ft	-	-	-	-
Balance of Feedstock Logistics					
Total Cost Contribution	\$/dry ton (without quality credit)	\$47.00	\$32.80	\$32.80	\$32.80
Capital Cost Contribution	\$/dry ton	\$12.60	\$8.70	\$8.70	\$8.70
Operating Cost Contribution	\$/dry ton	\$34.40	\$24.10	\$24.10	\$24.10
Value-Add Contribution (increased margin / more feedstock available)	\$/dry ton	\$0.00	\$0.00	\$0.00	\$4.50
Feedstock Case Reference (Model Run #)	INL Feedstock Model v2-12-07 ctw				

Table B-3. Technical Targets for Wet Herbaceous Biomass Feedstock Collection, Preprocessing and Delivery to Conversion Reactor Inlet

Processing Area Cost Contributions & Key Technical Parameters	Metric	Wet Herbaceous			
		2007	2009	2012	2017
Process Concept: Feedstock Collection, Preprocessing and Delivery to Conversion Reactor Inlet					
Year \$ basis		2007	2007	2007	2007
Total Cost of Feedstock Logistics	\$/dry ton (without quality credit)	\$88.20	\$66.10	\$45.10	\$41.70
Overall Logistics Efficiency (output/input)	% (dry matter basis)	80	85	90	95
Harvest and Collection					
Total Cost Contribution	\$/dry ton	\$29.50	\$20.70	\$10.60	\$10.60
Capital Cost Contribution	\$/dry ton	\$12.50	\$8.80	\$4.70	\$4.70
Operating Cost Contribution	\$/dry ton	\$17.00	\$11.90	\$5.90	\$5.90
Collection Efficiency	% improvement over baseline	-	30	65	65
Single-Pass Capacity	dry tons/hr	8	8	16	16
Selective Harvest Feedstock Quality	change in \$/dry ton	-	-	\$2.30	\$2.30
Storage and Queuing					
Total Cost Contribution	\$/dry ton	\$22.20	\$17.80	\$11.10	\$8.60
Capital Cost Contribution	\$/dry ton	\$10.00	\$8.00	\$5.00	\$2.60
Operating Cost Contribution	\$/dry ton	\$12.20	\$9.80	\$6.10	\$6.00
Shrinkage	% dry matter loss	>15	15	10	<5
Storage Quality	change in \$/dry ton	-	-	\$7.70	\$7.70
Preprocessing					
Total Cost Contribution	\$/dry ton	\$16.40	\$11.50	\$8.70	\$7.80
Capital Cost Contribution	\$/dry ton	\$3.90	\$2.70	\$1.80	\$1.50
Operating Cost Contribution	\$/dry ton	\$12.50	\$8.80	\$6.90	\$6.30
Capacity	dry tons/kW-hr	-	0.025	0.025	0.034
Bulk Density	dry lbs/cu-ft	-	7	7	12
Preprocessing Quality	change in \$/dry ton	-	-	\$2.30	\$2.30
Transportation and Handling					
Total Cost Contribution	\$/dry ton	\$20.10	\$16.10	\$14.70	\$14.70
Capital Cost Contribution	\$/dry ton	\$3.10	\$2.50	\$3.10	\$3.10
Operating Cost Contribution	\$/dry ton	\$17.00	\$13.60	\$11.60	\$11.60
Plant Conveying Bulk Density	dry lbs/cu-ft	-	5	5	5
Plant Storage Bulk Density	dry lbs/cu-ft	-	9	9	9
Field Bulk Density	dry lbs/cu-ft	-	-	-	-
Balance of Feedstock Logistics					
Total Cost Contribution	\$/dry ton (without quality credit)	\$88.20	\$66.10	\$45.10	\$41.70
Capital Cost Contribution	\$/dry ton	\$29.50	\$22.00	\$14.60	\$11.90
Operating Cost Contribution	\$/dry ton	\$58.70	\$44.10	\$30.50	\$29.80
Value-Add Contribution (increased margin / more feedstock available)	\$/dry ton	\$0.00	\$0.00	\$12.30	\$12.30
Feedstock Case Reference (Model Run #)	INL Feedstock Model v2-12-07 ctw				

Table B-4. Unit Operation Cost Contribution Estimates (2007\$) and Technical Targets for Corn Stover to Ethanol Baseline Process Concept

(Process Concept: Dry Corn Stover, Dilute Acid Pretreatment, Enzymatic Hydrolysis and Co-Fermentation, Lignin Combustion for Combined Heat and Power)

Processing Area Cost Contributions & Key Technical Parameters	Metric	2005	2009	2012
Process Concept: Dilute Acid Pretreatment, Enzymatic Hydrolysis, Ethanol Fermentation and Recovery, Lignin Combustion for CHP		Corn Stover	Corn Stover	Corn Stover
Year \$ basis		2007	2007	2007
Minimum Ethanol Production Processing Ccost	\$/gal EtOH	\$1.59	\$1.35	\$0.82
Total Project Investment per Annual Gallon	\$	\$5.11	\$4.46	\$3.17
Plant Capacity (Dry Feedstock Basis)	Tonnes/day	2000	2000	2000
Ethanol Yield	gal EtOH/dry US ton	65.3	74.3	89.8
Prehydrolysis/ treatment				
Total Cost Contribution	\$/gal EtOH	\$0.44	\$0.31	\$0.25
Capital Cost Contribution	\$/gal EtOH	\$0.20	\$0.17	\$0.14
Operating Cost Contribution	\$/gal EtOH	\$0.24	\$0.13	\$0.11
Solids Loading	wt%	30%	30%	30%
Xylan to Xylose	%	68%	75%	90%
Xylan to Degradation Products	%	13%	6%	5%
Xylan Sugar Loss	%	13%	7%	0%
Glucose Sugar Loss	%	12%	6%	0%
Enzymes				
Total Cost Contribution	\$/gal EtOH	\$0.32	\$0.33	\$0.10
Capital Cost Contribution	\$/gal EtOH	N/A	NA	N/A
Operating Cost Contribution	\$/gal EtOH	\$0.32	\$0.33	\$0.10
Saccharification & Fermentation				
Total Cost Contribution	\$/gal EtOH	\$0.31	\$0.27	\$0.10
Capital Cost Contribution	\$/gal EtOH	\$0.12	\$0.11	\$0.05
Operating Cost Contribution	\$/gal EtOH	\$0.19	\$0.17	\$0.05
Total Solids Loading	wt%	20%	20%	20%
Combined Sacc./Fermentation Time	days	7	7	3
Overall Cellulose to Ethanol	%	86%	86%	86%
Xylose to Ethanol	%	76%	80%	85%
Minor Sugars to Ethanol	%	0%	40%	85%
Distillation & Solids Recovery				
Total Cost Contribution	\$/gal EtOH	\$0.18	\$0.17	\$0.15
Capital Cost Contribution	\$/gal EtOH	\$0.15	\$0.13	\$0.12
Operating Cost Contribution	\$/gal EtOH	\$0.04	\$0.04	\$0.03
Steam Use	lb stm/gal EtOH	54		45
Moisture Content of Solids	% water by wgt	15%		15%
Balance of Plant				
Total Cost Contribution	\$/gal EtOH	\$0.34	\$0.27	\$0.22
Capital Cost Contribution	\$/gal EtOH	\$0.39	\$0.33	\$0.26
Operating Cost Contribution	\$/gal EtOH	-\$0.05	-\$0.06	-\$0.04
Co-Product Credit - Electricity	\$/gal EtOH	-\$0.17	-\$0.14	\$0.11
Co-Product Credit - Other	\$/gal EtOH	0	0	0
Electricity Production	KWHr/gal EtOH	4.4	3.5	2.4
Water Consumption	gal H2O/Gal EtOH	10.2		6.2
Fuel Ethanol Case Reference (Model Run #)		J0507B	J0610FY09	J0601A. Throat. 2000.35

Table B-5: Unit Operation Cost Contribution Estimates (2007\$) and Technical Targets for Thermochemical Conversion to Ethanol Baseline Process Concept

(Process Concept: Hybrid Poplar Woody Energy Crop, Gasification, Gas Cleanup, Mixed Alcohol Synthesis, Ethanol Recovery and Purification)

Processing Area Cost Contributions & Key Technical Parameters	Metric	2005	2009	2012
Process Concept: Gasification, Syngas Cleanup, Mixed Alcohol Synthesis & Recovery		Hybrid Poplar	Hybrid Poplar	Hybrid Poplar
Minimum Ethanol Production Processing Cost	\$/gal EtOH	\$ 1.21	\$ 1.11	\$ 0.82
Total Project Investment per Annual Gallon	\$	\$ 5.34	\$ 4.87	\$ 4.30
Plant Capacity (Dry Feedstock Basis)	Tonnes/day	2000	2000	2000
Ethanol Yield	gal EtOH/dry ton	63.2	67	69.8
Mixed Alcohol Yield	gal MA/dry ton	74.5	79	82.3
Feed Handling and Drying				
Total Cost Contribution	\$/gal EtOH	\$ 0.18	\$ 0.17	\$ 0.16
Capital Cost Contribution	\$/gal EtOH	\$ 0.13	\$ 0.12	\$ 0.12
Operating Cost Contribution	\$/gal EtOH	\$ 0.05	\$ 0.05	\$ 0.05
Feed Moisture Content to Gasifier	wt % H2O	5%	5%	5%
Gasification				
Total Cost Contribution	\$/gal EtOH	\$ 0.14	\$ 0.13	\$ 0.13
Capital Cost Contribution	\$/gal EtOH	\$ 0.07	\$ 0.07	\$ 0.07
Operating Cost Contribution	\$/gal EtOH	\$ 0.07	\$ 0.06	\$ 0.06
Syngas Yield	lb/lb dry feed	0.82	0.82	0.82
Raw Syngas Methane (dry basis)	Mole %	15%	15%	15%
Gasifier Efficiency (LHV)	% LHV	76.1%	76.1%	76.1%
Synthesis Gas Clean-up & Conditioning				
Total Cost Contribution	\$/gal EtOH	\$ 0.69	\$ 0.62	\$ 0.43
Capital Cost Contribution	\$/gal EtOH	\$ 0.38	\$ 0.35	\$ 0.30
Operating Cost Contribution	\$/gal EtOH	\$ 0.31	\$ 0.28	\$ 0.13
Tar Reformer (TR) Exit CH4 (dry basis)	Mole %	14%	4%	1.7%
TR Light CH4 Conversion	%	20%	50%	75%
TR Benzene Conversion	%	70%	90%	97%
TR Heavy HC/Tar Conversion	%	95%	97%	99%
Sulfur Level in Clean Gas (as H2S)	ppmv	50	50	50
Fuels Synthesis				
Total Cost Contribution	\$/gal EtOH	\$ 0.08	\$ 0.05	\$ (0.03)
Capital Cost Contribution	\$/gal EtOH	\$ 0.22	\$ 0.19	\$ 0.14
Operating Cost Contribution	\$/gal EtOH	\$ (0.14)	\$ (0.15)	\$ (0.16)
Pressure	psia	2000	2000	1000
Single Pass CO Conversion	% CO	40.0%	40.0%	50%
Overall CO Conversion	% CO	40.0%	40.0%	50%
Selectivity to Alcohols	% CO	80.0%	80.0%	80.0%
Product Recovery and Purification				
Total Cost Contribution	\$/gal EtOH	\$ 0.05	\$ 0.05	\$ 0.05
Capital Cost Contribution	\$/gal EtOH	\$ 0.04	\$ 0.03	\$ 0.03
Operating Cost Contribution	\$/gal EtOH	\$ 0.01	\$ 0.01	\$ 0.01
Co-Product Credit - Mixed Alcohols	\$/gal EtOH	\$ 0.21	\$ 0.21	\$ 0.21
Key Variable ?	?			
Balance of Plant				
Total Cost Contribution	\$/gal EtOH	\$ 0.08	\$ 0.10	\$ 0.08
Capital Cost Contribution	\$/gal EtOH	\$ 0.12	\$ 0.11	\$ 0.11
Operating Cost Contribution	\$/gal EtOH	\$ (0.04)	\$ (0.02)	\$ (0.03)
Co-Product Credit - Other	\$/gal EtOH	\$0.04	\$0.01	0.032
Electricity Production	KWHr/gal EtOH	0.61	0.17	0.54
Water Consumption	gal H2O/Gal EtOH	3.2	3.2	2.9
Year \$ basis		2007	2007	2007
Fuel Ethanol Case Reference (Model Run #)		AA0704F	AA0704C	A0710F

APPENDIX C: CALCULATION METHODOLOGY FOR ETHANOL COST OF PRODUCTION TARGETS

The two primary goals of this Appendix are to:

- 1) summarize the bases for current and recent ethanol cost targets and
- 2) explain the general methodology used to develop the cost estimates and adjust them to different year dollars.

Table C-1 describes the three primary documents, including this MYPP, that cover the evolution of technology design and ethanol cost targets for a specific biochemical conversion concept. Additional details for the technical performance targets and cost targets can be found in Appendix B.

Table C-1: Primary Source Documents for Program Ethanol Cost Targets

Document	Design and Cost Information : Bases and Differences
2002 Corn Stover to Ethanol Design Report ¹	<ul style="list-style-type: none"> • Ethanol Market Target of \$1.07 (2000\$) to be competitive with corn ethanol. • First design report for an agricultural residue feedstock • Assumed \$30/dry ton feedstock cost delivered to the plant in bales • Detailed conversion plant process design, factored capital cost estimate, operating cost estimate, and discounted cash flow rate of return used to determine ethanol cost target • Costs based on year 2000 dollars
2005 MYPP ² with Feedstock Logistics Estimates	<ul style="list-style-type: none"> • Ethanol Cost Target of \$1.08 (2002\$) in 2020 • First Program plan with feedstock cost components identified. • Feedstock grower payment assumed at \$10/ton, although it is understood that this is a point on the supply curve that would correspond to a relatively low level of available agricultural residue type feedstock. • Feedstock logistics estimated cost at \$25/dry ton based on unit operations breakdown including preprocessing and handling that included equipment and operations up to the pretreatment reactor throat. • De tailed conversion plant design virtually the same as in the 2002 design report, but backed out feedstock handling system equipment and operation now included in feedstock logistics. Several additional minor modifications and corrections made to original design with no significant cost impact. • Conversion costs escalated to year 2002 dollars.
2007 MYPP	<ul style="list-style-type: none"> • Cost target of ~ \$1.30 (2007\$) in 2012 • Feedstock grower payment escalated to \$13/ton, although it is still and assumed number and understood that it is a point on the supply curve that would correspond to a relatively low level of available agricultural residue type feedstock. • Feedstock logistics cost breakdown updated based on first detailed design report covering this portion of the supply chain. • Detailed conversion plant design virtually the same as used in the 2005 MYPP case. • All costs escalated to 2007 year dollars.

¹ Lignocellulosic Biomass to Ethanol Process Design and Economics Utilizing Co-Current Dilute Acid Prehydrolysis and Enzymatic Hydrolysis for Corn Stover,” NREL TP-510-32438, June 2002.

² Multi Year Program Plan 2007-2012, Office of the Biomass Program, EERE/DOE, August 31, 2005.

Table C-2 shows the cost breakdown of the ethanol targets for the three cases in described in Table C-1 based on the first three major elements of the biomass-to-biofuels supply chain: feedstock production, feedstock logistics, and biomass conversion, and their associated sub-elements. Notice that the ethanol yields for each of the three cases are nearly identical. This is an indication that the technical aspects of the targeted performance for the biomass conversion element are not changing between the cases.

Table C-2: Ethanol Production Cost Target Breakdown by Supply Chain Element

Supply Chain Areas	Units	2002 Corn Stover-to-Ethanol Design Report	2005 MYPP with Feedstock Logistics Estimates	2007 MYPP – 2012 Target
Year \$s	Year	2000	2002	2007
Feedstock Production				
Grower Payment	\$/dry ton	\$10.00	\$10.00	\$13.00
Feedstock Logistics				
Harvest and Collection	\$/dry ton		\$12.50	\$10.60
Storage and Queuing	\$/dry ton		\$1.75	\$3.70
Preprocessing	\$/dry ton		\$2.75	\$6.20
Transportation and Handling	\$/dry ton		\$8.00	\$12.30
Logistics Subtotal	\$/dry ton	\$20.00	\$25.00	\$32.80
Feedstock Total	\$/dry ton	\$30.00	\$35.00	\$45.90
Ethanol Yield	gal EtOH/ dry ton	89.7	89.8	89.8
Feedstock Production				
Grower Payment	\$/gal EtOH	\$0.111	\$0.111	\$0.146
Feedstock Logistics				
Harvest and Collection	\$/gal EtOH		\$0.14	\$0.12
Storage and Queuing	\$/gal EtOH		\$0.02	\$0.04
Preprocessing	\$/gal EtOH		\$0.03	\$0.07
Transportation and Handling	\$/gal EtOH		\$0.09	\$0.14
Logistics Subtotal	\$/gal EtOH	\$0.22	\$0.28	\$0.37
Feedstock Total	\$/gal EtOH	\$0.33	\$0.39	\$0.51
Biomass Conversion				
Feedstock Handling	\$/gal EtOH	\$0.06	\$0.00	\$0.00
Prehydrolysis/ treatment	\$/gal EtOH	\$0.20	\$0.21	\$0.25
Enzymes	\$/gal EtOH	\$0.10	\$0.10	\$0.10
Saccharification & Fermentation	\$/gal EtOH	\$0.09	\$0.09	\$0.10
Distillation & Solids Recovery	\$/gal EtOH	\$0.13	\$0.13	\$0.15
Balance of Plant	\$/gal EtOH	\$0.16	\$0.17	\$0.22
Conversion Total	\$/gal EtOH	\$0.74	\$0.69	\$0.82
Ethanol Production Total	\$/gal EtOH	\$1.07	\$1.08	\$1.33

The major difference between the 2002 design report and the 2005 MYPP is in where some of the feedstock processing and handling resides, but notice that the overall costs do not change

dramatically. The primary difference between the 2005 and 2007 is due to changing from 2002 \$s to 2007\$s. It is important to note that the cost for feedstock production is just an assumed value for all the cases. The Program is in the process of developing feedstock supply curves for the different feedstock types in the Billion Ton Study. This information is crucial to understanding the range of feedstock costs to be expected as the biomass industry evolves.

The ethanol production cost targets are estimated mature technology processing costs which means that the capital and operating costs are assumed to be for an “nth plant” where several plants have been built and are operating successfully so that additional costs for risk financing, longer startups, under performance, and other costs associated with pioneer plants are not included.

General Cost Estimation Methodology

The Program uses consistent, rigorous engineering approaches for developing detailed process designs, simulation models, and cost estimates, which in turn are used to estimate the minimum cost of ethanol production using a standard discounted cash flow rate of return calculation. The feedstock logistics element uses economic approaches to costing developed by the American Society of Agricultural and Biological Engineers. The Program has recently developed a standard analytical protocol, based on industrial chemical engineering approaches, for all its conceptual process design efforts to ensure consistency and comparability of results. Details of the approaches and results of the technical and financial analyses are thoroughly documented in the Program’s conceptual design reports³ and will not be repeated here.

What will be covered is a high level, general description of how costs are developed and how the costs are escalated to different year dollars. Cost estimate development is slightly different between the feedstock logistics and biomass conversion elements, but generally both elements include capital costs, costs for chemicals and other material and labor costs. Table C-3 compares the cost indices for these three categories of costs in 2000, 2002, and 2007; the three years of the cost bases in the three cases in Table C-1.

³ The three major Program design reports are:

- 1) “Lignocellulosic Biomass to Ethanol Process Design and Economics Utilizing Co-Current Dilute Acid Prehydrolysis and Enzymatic Hydrolysis for Corn Stover,” NREL TP-510-32438, June 2002.
- 2) “Thermochemical Ethanol via Indirect Gasification and Mixed Alcohol Synthesis of Lignocellulosic Biomass,” NREL/TP-510-41168, April 2007.
- 3) Feedstock Logistics Design Report, final editing in progress as of 09/27/07.

Table C-3: Comparison of Cost Index Values for Plant Capital, Chemicals and Materials and Labor for 200, 2002 and 2007

Cost Component	2000 Index	2002 Index	% change, 2000- 2002	2007 Extrapolated Index	% change 2002-2007
Plant Capital	394.1	395.6	0.4	471.1	19.1
Chemicals & Materials	156.7	157.3	0.4	194.1	23.4
Labor	17.09	17.97	5.1	20.21	12.5

The indices for plant capital and chemicals and materials have increased significantly since 2003 while the labor index has shown a consistent, if steady rise of about 2.5 % per year. As was mentioned earlier, the target technical plant designs were not changed significantly among the three cases including the material and energy balances, equipment sizing, labor levels, and quantities of chemical and materials inputs. What were changed were the costs of these various factors. The process and economic models constructed for the feedstock logistics and biomass conversion elements have been developed so that it is straightforward, usually within a spreadsheet, to adjust the year dollars of the cost estimate by applying the appropriate index value to each cost item.

The total project investment (based on total equipment cost) as well as variable and fixed operating costs, are developed first, using the best available cost information. Cost information typically comes from a range of years and so all cost components must be adjusted to a common year. For the 2007 MYPP case each cost component was adjusted based on the ratio of an extrapolated 2007 index to the actual index for the particular cost component. The delivered feedstock cost was treated as an operating cost for the biomass conversion facility. With these costs, a discounted cash flow analysis of the conversion facility was carried out to determine the production cost of ethanol when the net present value of the project is zero.

Total Project Investment Estimates and Cost Escalation

The Program design reports include detailed equipment lists with sizes and costs and details about how the purchase cost of all equipment was determined. For the feedstock logistics element some of the equipment, such as harvesters and trucks, does not require an additional installation cost, however, other logistics equipment and the majority of the conversion facility equipment will be installed. For the types of conceptual designs the Program carries out, a “factored” approach is used.

Once the installed equipment cost has been determined from the purchased cost and the installation factor, it can be indexed to the project year being considered. The purchase cost of each piece of equipment has a year associated with it. The purchased cost year will be indexed to the year of interest using the Chemical Engineering Plant Cost Index.

Figure C-1 and Table C-4 show the historical values of the index as well as two types of extrapolation. Notice that the index was relatively flat between 2000 and 2002 with less than a 0.4% increase, while between 2002 and 2005 there was a nearly 18% jump. This dramatic increase in equipment costs, which directly impacts the total project capital investment and the extrapolation to 2007 is a major reason for the significant change in the value of the ethanol cost target between the 2005 and 2007 MYPPs.

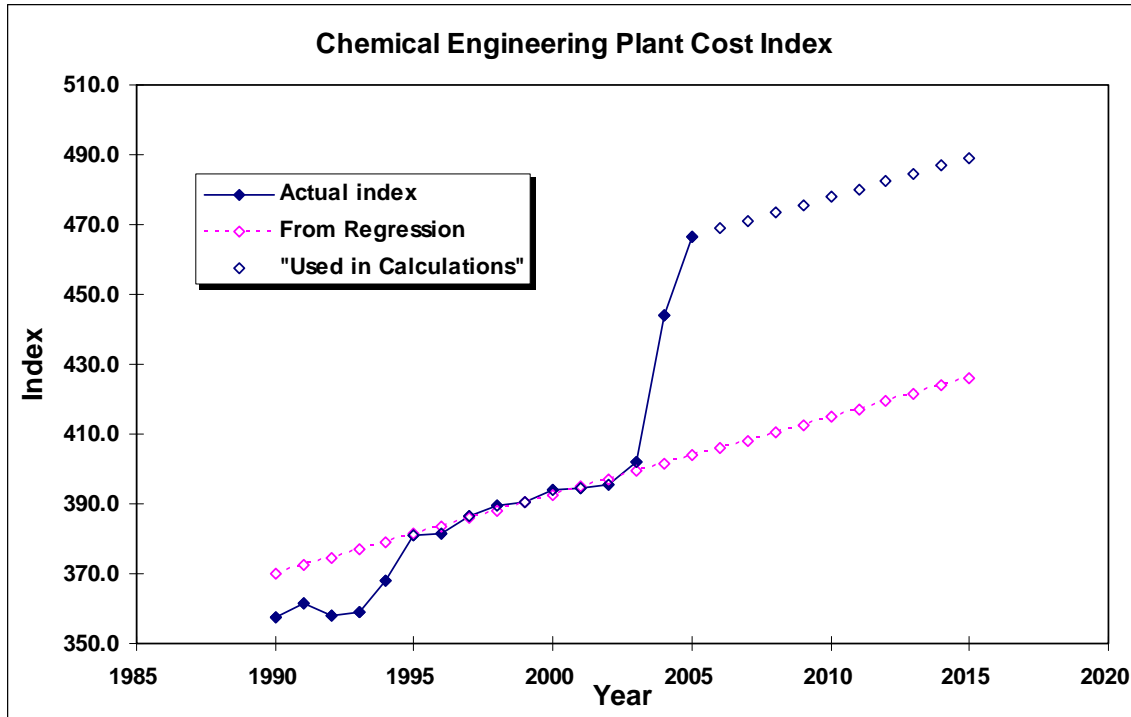

Figure C-1: Actual and Extrapolated Plant Cost Index (see Table C-4 for values)

For equipment cost items in which actual cost records do not exist, a representative cost index is used. For example, the USDA publishes Prices Paid by Farmers indexes that are updated monthly. These indexes represent the average costs of inputs purchased by farmers and ranchers to produce agricultural commodities and a relative measure of historical costs. For machinery list prices, the Machinery Index was used, and for machinery repair and maintenance costs, the Repairs Index was used. These USDA indexes were used for all machinery used in the feedstock supply system analysis, including harvest and collection machinery (combines, balers, tractors, etc.), loaders and transportation-related vehicles, grinders, and storage-related equipment and structures.

Operating Cost Estimates and Cost Escalation

Variable operating costs, which include fuel inputs, raw materials, waste handling charges, and by-product credits, are incurred when the process is operating and are a function of the process throughput rate. All raw material quantities used and wastes produced are determined as part of the detailed material and energy balances carried out for all the process steps. As with capital equipment, the costs for chemicals and materials are associated with a particular year. The U.S. Producer Price Index from SRI Consulting was used as the index for all chemicals and materials. Available data were regressed to a simple equation and used to extrapolate to future years, as shown in Figure C-2 and Table C-5.

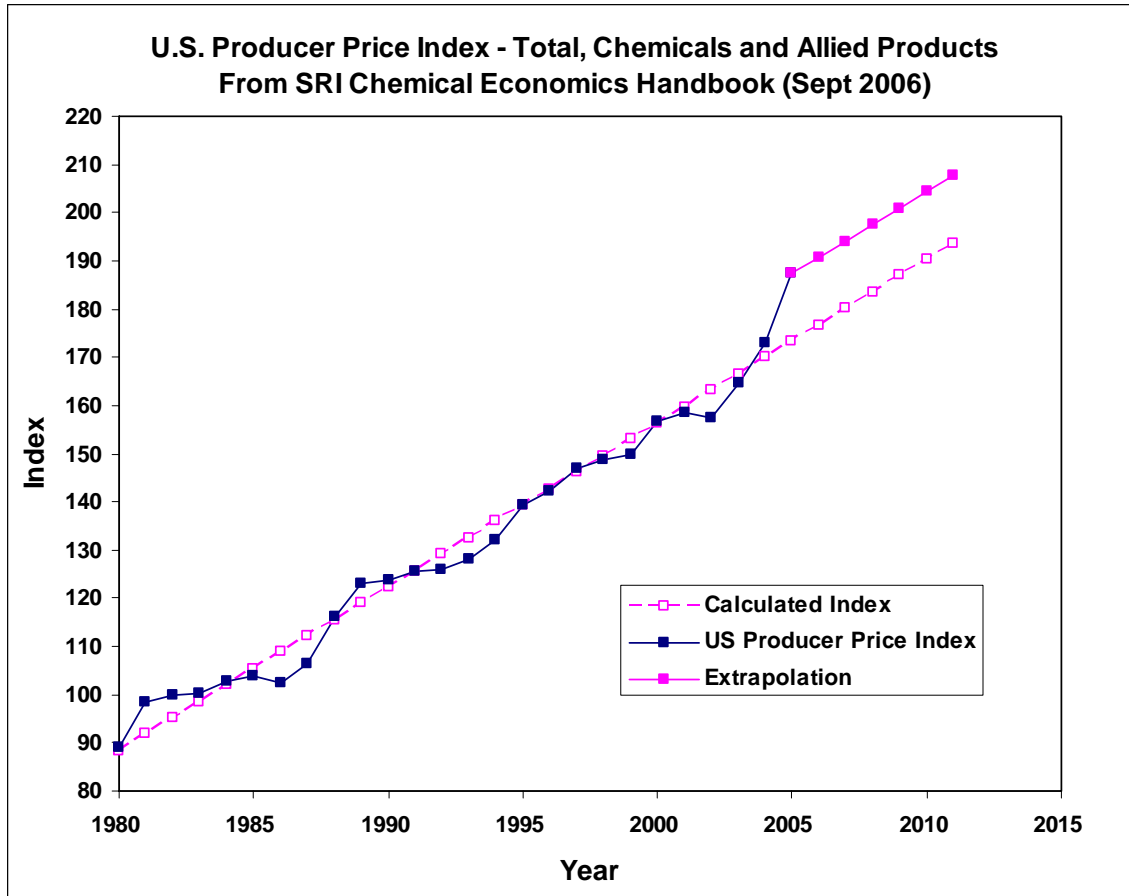

Figure C-2: Actual and Extrapolated Chemical Cost Index (see Table C-5 for values)

Some types of labor, especially related to feedstock production and logistics are variable costs, while labor associated with the conversion facility are considered fixed operating costs.

Fixed operating costs are generally incurred fully whether or not operations are running at full capacity. Various overhead items are considered fixed costs in addition to some types of labor. General overhead is generally a factor applied to the total salaries and covers items such as safety, general engineering, general plant maintenance, payroll overhead (including benefits), plant security, janitorial and similar services, phone, light, heat, and plant communications. Annual maintenance materials are generally estimated as a small percentage (e.g. 2%) of the total installed equipment cost. Insurance and taxes are generally estimated as estimated as a small percentage (e.g. 1.5%) of the total installed cost. The index to adjust labor costs is taken from the Bureau of Labor Statistics and is shown in Figure C-3 and Table C-6. The available data were regressed to a simple equation and the resulting regression equation used to extrapolate to future years.

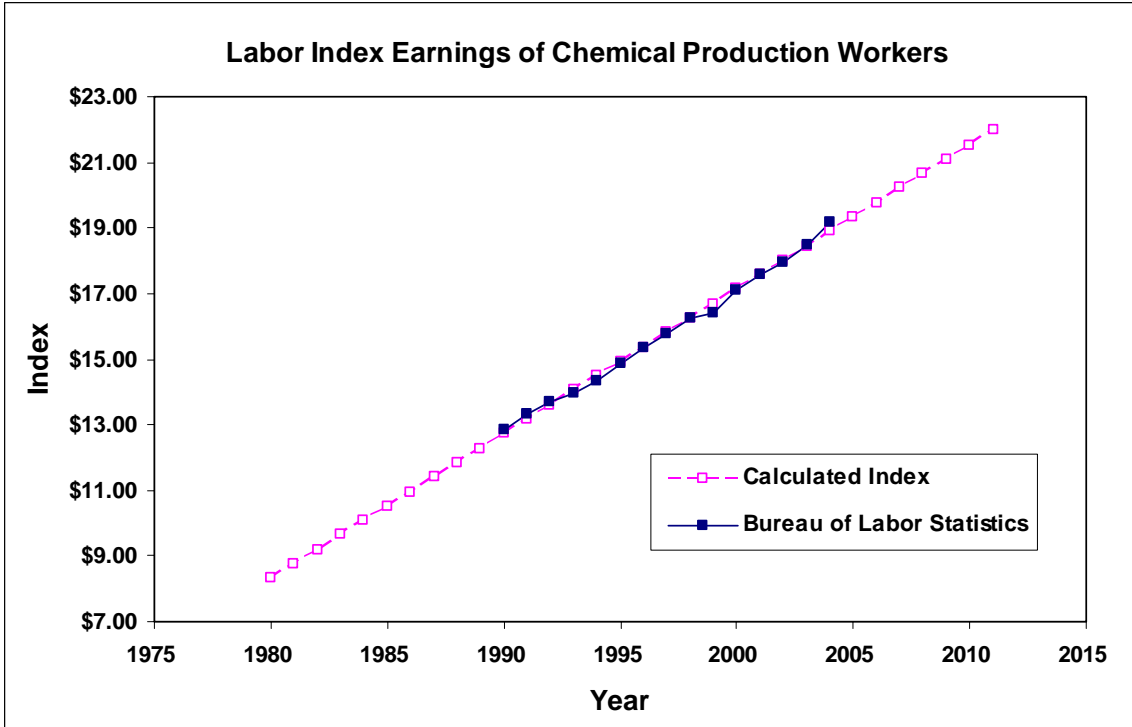

Figure C-3: Actual and Extrapolated Labor Cost Index (see Table C-6 for values)

Discounted Cash Flow Analysis and the Selling Cost of Ethanol

Once the two major cost areas have been determined—(1) total project investment and (2) operating costs—a discounted cash flow analysis can be used to determine the minimum selling price per gallon of ethanol produced. The discounted cash flow analysis program iterates on the selling cost of ethanol until the net present value of the project is zero. This analysis requires that the discount rate, depreciation method, income tax rates, plant life, and construction start-up duration be specified. The Program has developed a standard set of assumptions that are used in carrying out the discounted cash flow analysis.

Table C- 4: Plant Cost Indices

Source	Year	CE Annual Index	Calculated Index	Index Used in Cales
(1)	1990	357.6	370.1	357.6
(1)	1991	361.3	372.4	361.3
(1)	1992	358.2	374.6	358.2
(1)	1993	359.2	376.8	359.2
(1)	1994	368.1	379.1	368.1
(1)	1995	381.1	381.3	381.1
(1)	1996	381.7	383.6	381.7
(2)	1997	386.5	385.8	386.5
(2)	1998	389.5	388.1	389.5
(3)	1999	390.6	390.3	390.6
(4)	2000	394.1	392.5	394.1
(5)	2001	394.3	394.8	394.3
(5)	2002	395.6	397.0	395.6
(6)	2003	402.0	399.3	402.0
(6)	2004	444.2	401.5	444.2
(6)	2005	466.7	403.8	466.7
	2006		406.0	468.9
	2007		408.2	471.1
	2008		410.5	473.4
	2009		412.7	475.6
	2010		415.0	477.9
	2011		417.2	480.1
	2012		419.5	482.4
	2013		421.7	484.6
	2014		423.9	486.8
	2015		426.2	489.1

Sources:

- (1) Chemical Engineering Magazine, March, 1997
 - (2) Chemical Engineering Magazine, March, 2000
 - (3) Chemical Engineering Magazine, January, 2001
 - (4) Chemical Engineering Magazine, April, 2002
 - (5) Chemical Engineering Magazine, December, 2003
 - (6) Chemical Engineering Magazine, May 2005
- Current indices @ <http://www.che.com/ei>

Table C-5: US Producer Price Index – Total, Chemicals and Allied Products

Year	US Producer Price Index	Calculated Index	Index Used
1980	89.0	88.4	89.0
1981	98.4	91.8	98.4
1982	100.0	95.2	100.0
1983	100.3	98.6	100.3
1984	102.9	102.0	102.9
1985	103.7	105.4	103.7
1986	102.6	108.8	102.6
1987	106.4	112.2	106.4
1988	116.3	115.6	116.3
1989	123.0	119.0	123.0
1990	123.6	122.4	123.6
1991	125.6	125.8	125.6
1992	125.9	129.2	125.9
1993	128.2	132.6	128.2
1994	132.1	135.9	132.1
1995	139.5	139.3	139.5
1996	142.1	142.7	142.1
1997	147.1	146.1	147.1
1998	148.7	149.5	148.7
1999	149.7	152.9	149.7
2000	156.7	156.3	156.7
2001	158.4	159.7	158.4
2002	157.3	163.1	157.3
2003	164.6	166.5	164.6
2004	172.8	169.9	172.8
2005	187.3	173.3	187.3
2006		176.7	190.7
2007		180.1	194.1
2008		183.5	197.5
2009		186.9	200.9
2010		190.3	204.3
2011		193.7	207.7

Source:

SRI International Chemical Economics Handbook, Economic Environment of the Chemical Industry 2006

Current indices @ <https://www.sriconsulting.com/CEH/Private/EECI/EECI.pdf>

Table C-6: Labor Index

Year	Reported	Calculated	Index Used
1980		8.32	8.32
1981		8.76	8.76
1982		9.20	9.20
1983		9.64	9.64
1984		10.08	10.08
1985		10.52	10.52
1986		10.96	10.96
1987		11.40	11.40
1988		11.84	11.84
1989		12.28	12.28
1990	12.85	12.72	12.85
1991	13.30	13.16	13.30
1992	13.70	13.60	13.70
1993	13.97	14.04	13.97
1994	14.33	14.48	14.33
1995	14.86	14.92	14.86
1996	15.37	15.36	15.37
1997	15.78	15.81	15.78
1998	16.23	16.25	16.23
1999	16.40	16.69	16.40
2000	17.09	17.13	17.09
2001	17.57	17.57	17.57
2002	17.97	18.01	17.97
2003	18.50	18.45	18.50
2004	19.16	18.89	19.16
2005		19.33	19.33
2006		19.77	19.77
2007		20.21	20.21
2008		20.65	20.65
2009		21.09	21.09
2010		21.53	21.53
2011		21.97	21.97

Source:
 Bureau of Labor Statistics, Series ID: CEU3232500006
 Chemicals Average Hourly Earnings of Production Workers
 Current indices from <http://data.bls.gov/cgi-bin/srgate>

APPENDIX D: Matrix of Revisions

Section Name	Specific Reference	Revision	Version Change was Implemented
Document Wide	All figures and descriptions	Updated all the Pathway names with the revised names	March 1st Version
Exec Summary	Figure C	Updated milestones in Figure C	March 1st Version
Section 1	Energy Independence and Security Act of 2007 (call out box)	Added a call out box on the Energy Independence and Security Act of 2007	March 1st Version
Section 1	Figure 1-10	Figure 1-10 updated for 2022	March 1st Version
Section 1	Figure 1-13	Added 2007 status	March 1st Version
Section 1	Figure 1-9	Added EISA to this diagram	March 1st Version
Appendix A	Table A-1	Revised wording and spacing of the milestones	March 1st Version
Appendix A	Figure A-2 and A-5	Updated the pathway diagrams for the energy crops processing and corn dry mill pathways	March 1st Version