



Brian Schweitzer, Governor

P.O. Box 200901 • Helena, MT 59620-0901 • (406) 444-2544 • www.deq.mt.gov

April 6, 2005

Dear Interested Citizen:

The Montana Department of Environmental Quality (MDEQ) is announcing a 30-day public scoping period under the Montana Environmental Policy Act (MEPA) for the following proposed project and its related state permits:

**Highwood Generation Station Unit #1
A 250 megawatt (MW) Coal-Fired Electrical Generating Facility
near Great Falls, Montana**

Southern Montana Electric Generation and Transmission Cooperative, Inc. (SME) is proposing to construct a 250 MW coal-fired power plant at a site near Great Falls (Highwood Generation Station Unit #1). SME conducted an alternatives analysis to meet the power needs of its customers and concluded that owning its own source of electrical generation is in the best interests of its members. Results of a statewide power plant siting study by SME identified two sites near Great Falls as having the best attributes to support a coal-fired generation plant. Further details on the proposal is provided in the enclosed scoping document.

MDEQ is entrusted with the authority to review and issue environmental permits required for discharges from power generation and other industrial facilities. The department must conduct an environmental analysis under MEPA of its decision regarding these environmental permits. Because SME applied for financing for the project from the Rural Utility Service (RUS), U.S. Department of Agriculture, RUS must also conduct an environmental analysis of the project under the National Environmental Policy Act (NEPA). MDEQ will prepare and issue a joint environmental impact statement (EIS) for the project with RUS.

MDEQ is holding a public meeting and will collect comments during a 30-day public comment period on the state permits and licenses that SME would need to implement its proposed power plant. RUS conducted a public scoping meeting and received public comments on the proposed project during the fall of 2004. The purpose of public scoping is to allow interested members of the public to express their comments and concerns regarding the proposed project and associated permits. The agencies will then consider those comments and concerns in determining the issues to be addressed in the EIS.

You are invited to attend MDEQ's public scoping meeting as outlined below. The department will make reasonable accommodations for persons with disabilities who wish to participate in

this meeting. If you require an accommodation, please contact the MDEQ at the address below no later than April 13, 2005:

**Public Scoping Meeting
on the Preparation of an EIS for
Southern Montana Electric Generation and Transmission Cooperative's
Highwood Generation Station Unit #1**

***Location: Great Falls Civic Center, Missouri Room
Time: April 18, 2005, 7:00 p.m.***

You may submit written comments or concerns to MDEQ at the meeting. Or, if you wish, you may mail or e-mail them to MDEQ at the addresses listed below no later than May 6, 2005:

Kathleen Johnson, MEPA Coordinator
Re: SME's Highwood Generating Station EIS
Montana Department of Environmental Quality
P.O. Box 200901
Helena, MT 59620-0901
406-444-1760
katjohnson@mt.gov

If you already submitted comments to RUS during its scoping period, it is not necessary for you to comment again to MDEQ during the State's scoping period unless you have new or additional concerns. Both agencies will consider all comments received by RUS as well as MDEQ when preparing the draft and final EISs.

Sincerely,



Thomas M. Ellerhoff
Environmental Program Manager

Scoping Document

For the Preparation of an Environmental Impact Statement

for

Southern Montana Electric Generation and Transmission Cooperative's

Highwood Generating Station Unit #1

Prepared by-

Montana Department of Environmental Quality

Prepared for-

EIS Scoping Meeting
Great Falls, MT
April 18, 2005

April 6, 2005
Scoping Document
For the Preparation of an Environmental Impact Statement
for
Southern Montana Electric Generation and Transmission Cooperative's
Highwood Generating Station Unit #1

Project Background

Southern Montana Electric Generation and Transmission Cooperative, Inc. (SME) is preparing to submit environmental permit applications to the Montana Department of Environmental Quality (MDEQ) and other agencies seeking permission to construct and operate a 250 megawatt (MW) coal-fired electric generating station. SME's project triggers a Montana Environmental Policy Act (MEPA) review. Highwood Generating Station Unit #1 is proposed to be located at a site near Great Falls, Montana, and would provide electricity to the transmission grid for delivery to SME members.

SME supplies electricity to five rural electric cooperatives in central and south-central Montana and a municipal utility as follows:

- Beartooth Electric Cooperative, Inc. with headquarters at Red Lodge, Montana;
- Fergus Electric Cooperative, Inc. with headquarters in Lewistown, Montana;
- Mid-Yellowstone Electric Cooperative, Inc. with headquarters at Hysham, Montana;
- Tongue River Electric Cooperative, Inc. with headquarters located at Ashland, Montana;
- Yellowstone Valley Electric Cooperative, Inc. with headquarters at Huntley, Montana;
- City of Great Falls, Montana.

Figure 1.0 shows the service territory of SME members on a Montana map with associated transmission facilities.

SME current power supply contracts with Bonneville Power Administration will start to expire in 2008, and be completely eliminated by 2011. To address future power supply needs of its members, SME conducted an alternative evaluation study under the guidance of the Rural Utility Service (RUS) of the U.S. Department of Agriculture (see *Alternative Evaluation Study, Southern Montana Electric Generation and Transmission Cooperative, Inc., Revision 1, October, 2004*). The alternative evaluation study, which can be found at www.usda.gov/rus/water/ees/eis.htm and www.deq.state.mt.us/eis.asp, identified a coal-fired power plant as the preferred option for supplying low cost electricity to SME members.

A site screening study was completed to identify a preferred site(s) for a coal-fired power plant in Montana (see *Site Screening Study, New Coal-Fired Power Plant, Southern Montana Electric Generation and Transmission Cooperative, Inc., October 2004*). The site screening study addressed RUS requirements for completion of a Site-Selection Study prior to the start of the scoping process for generation projects when an environmental impact statement (EIS) will be

involved. Results of the site screening study available on the RUS and MDEQ web sites (RUS - www.usda.gov/rus/water/ees/eis.htm and MDEQ - www.deq.state.mt.us/eis.asp) identified and described SME's plans for a 250 MW coal-fired power plant on a preferred site near Salem, Montana, east of Great Falls, Montana, and on an alternate site at the Great Falls Industrial Park.

Proposed Project

General Project Description. Highwood Generating Station Unit #1 (HGS) would be a 250 MW net coal-fired generation plant using circulating "fluidized bed" (CFB) combustion technology. The fluidized bed refers to large amounts of air that are blown into the combustor. The fuel, a low sulfur southern Montana coal, and limestone from a local source would be suspended in the combustion air stream as the fuel burns. The ash produced in the combustion process would be separated in the cyclone separator and the heavy bed material returned to the furnace. The continuous recycling of ash solids to the combustor would allow the CFB boiler to operate at lower firing temperatures than other types of coal-fired power plants. For example, CFB combustion temperatures are significantly lower than a conventional pulverized coal-fired boiler (less than 1500 degrees Fahrenheit (°F) vs. 3000 °F). These lower temperatures in combination with the CFB process would result in lower emissions and a reduction in slagging and fouling of the boiler.

The plant would be modeled after a public power project now in service in Maysville, Kentucky. Maps of the two proposed project sites in the Great Falls area are provided in Figures 2.0 and 3.0. Power from HGS is projected to be available to SME customers in 2010.

Electricity would be transmitted to the Great Falls substation located north of the Missouri River and City of Great Falls via a tie line to be constructed by SME. A second transmission line from the plant would be installed and would follow the rail spur line alignment to a new switchyard. The switchyard would be constructed on the existing NorthWestern Electric 230 kV transmission line from Great Falls to Broadview.

A rail spur line would be constructed east of Great Falls to connect to the Salem site. Access to the Salem site would be via U.S. Highway 89 east of Great Falls, Local Route 228 and County Road. The Great Falls Industrial Park site is located immediately north of Great Falls along U.S. Highway 87. The projected work force of 400 construction workers during peak construction and approximately 65 permanent power plant staff would find available housing and services in Great Falls and nearby communities due to the close proximity of the Salem and Great Falls Industrial Park sites.

Fuel and Supplies. The CFB boiler would burn sub-bituminous coal, delivered by railroad from southeast Montana coal mines. HGS coal consumption of approximately 1,200,000 tons per year would result in unit coal train deliveries (consisting of 110 rail cars of coal per unit train) to the facility about two times per week.

Natural gas would be supplied to the proposed project site for use as a start-up fuel via a pipeline. Limestone used in the pollution control equipment would be delivered by truck; quantities required would result in approximately four trucks of limestone per day. Ammonia

utilized in the nitrogen oxides (NO_x) control equipment would be delivered by truck resulting in one truck delivery about every month.

Water Management. The water supply for HGS would be pumped from an intake structure upstream of the Morony Dam on the Missouri River. The City of Great Falls has agreed to sell water rights to SME to meet water supply requirements for HGS up to 3200 gallons per minute. With a planned wet cooling system, HGS water supply needs are estimated to average 2500 gallons per minute. The water would be softened and filtered. The majority of the water (approximately 80%) would be used by the plant in the heat rejection cycle and would consist of the make-up supply to the cooling tower. The balance of the water would be treated in a reverse osmosis or demineralizer process and supplied as make-up to the steam generation cycle. Additional small quantities of water would be used for on site sanitary purposes.

Air Pollution Control. Air pollution control equipment would include four major pieces of equipment, which work in conjunction with each other to minimize total emissions. The CFB works in combination with a flash dryer absorber (FDA) for removing sulfur dioxide (SO₂) and with selective non-catalytic reduction to further reduce emissions of NO_x. A fabric filter or bag house is used to control particulate emissions. Figure 4.0 shows a diagram of a CFB combustion process and associated emissions control equipment.

The CFB process is the first step in controlling total plant emissions. The CFB technology uses a bed of crushed coal and limestone and recycled heavy ash particles suspended (fluidized) in an upwardly flowing air stream. Air enters the bottom of the furnace through air distribution nozzles. The coal and limestone are metered and fed into the furnace bed. Combustion takes place in the fluidized bed, which is limited in temperature to reduce the formation of NO_x. The fine particles of limestone react with the sulfur in the coal and reduce the formation of SO₂. The heavier combustion byproduct particles are carried in the flue gas through the furnace and collected in a cyclone separator. The heavy particles, a combination of ash resulting from the combustion of coal and limestone, are circulated back into the furnace.

A selective non-catalytic reduction (SNCR) system is the second step in NO_x emissions control. Ammonia is injected prior to the cyclone separator into the upper portion of the furnace, and mixed with the hot flue gas. The ammonia reacts with the flue gas to convert NO_x into nitrogen gas (N₂), and water vapor.

A flash dryer absorber (FDA) is the second step in SO₂ emission control. The FDA is a dry flue gas desulphurization process. The process is based on the reaction between SO₂ and a reagent, hydrated lime. The system mixes water, fly ash, and the available lime (produced during the combustion process of the limestone) outside of the flue gas stream, and injects the mixture into the flue gas upstream of the bag house filter system.

A fabric filter bag house is the second step in particulate emissions control. The bag house consists of multiple fabric bags that capture lighter particles in the exhaust gases downstream of the cyclone separator. These lighter particles include fly ash and any lighter solids created in the chemical reaction processes.

Air emissions from the facility would meet Best Available Control Technology (BACT) requirements as required by state and federal regulations. Preliminary estimates of potential CFB boiler emissions, including SO₂ and NO_x, and carbon monoxide (CO), volatile organic compounds¹ (VOC) and filterable particulate matter less than 10 microns in diameter (PM₁₀) from the facility are as follows:

- SO₂ - 440 tons/yr
- NO_x - 810 tons/yr
- CO - 1150 tons/yr
- VOC - 25 tons/yr
- PM₁₀ - 170 tons/yr

A test burn of Montana coal in a “pilot scale” CFB facility has been conducted to demonstrate the performance of the technology and to collect emissions data. The projected air emissions from the HGS CFB facility may be further refined upon review of the test burn emissions data. Additional emissions of particulate matter from the facility are anticipated from fuel and limestone handling and other fugitive sources. Estimates of PM₁₀ emissions from these sources are in the range of 50 tons/year.

Projected air emissions from HGS and from other surrounding industrial sources near Great Falls will be analyzed in a dispersion model to demonstrate that Prevention of Significant Deterioration (PSD) increments and state and federal ambient air quality standards are not exceeded. The HGS emissions will also be modeled for long-range transport and impacts to air quality-related values (e.g., visibility and acid deposition impacts) at nearby Class I areas (i.e., national parks and wilderness areas). Emissions impacts from HGS are currently being evaluated in the models on the assumption that the facility will have a 400-foot tall boiler stack.

Wastewater Treatment and Discharge. Wastewater from the HGS would be treated to meet water quality standards before being returned to the Missouri River. The wastewater would consist of concentrated river water, and trace amounts of cooling tower water and boiler water treatment chemicals. The anticipated volume of water discharge from the facility is 175 gallons per minute; the rest of the water obtained from the river would have evaporated from the cooling tower in the heat rejection cycle. Multiple combinations of water treatment equipment would be employed to meet the required discharge water quality requirements. Available technologies currently being analyzed include cold lime softening, and reverse osmosis water filtration systems.

¹ VOC means any compound of carbon, excluding carbon monoxide, carbon dioxide, carbonic acid, metallic carbides or carbonates, and ammonium carbonate, which participates in atmospheric photochemical reactions, and including any organic compound other than those found to have negligible photochemical reactivity. A list of organic compounds that are not VOC is provided in ARM 17.8.101(42).

Solid Waste Disposal. Waste products from coal combustion would consist of bed ash and fly ash and would total approximately 210 tons of ash per day. Waste products would be handled in a dry form, with dust abatement, and prepared for re-use or disposal. SME would prefer to find a beneficial use for the ash and intends to pursue marketing of the ash product. Potential uses of ash include road base, cement substitute for concrete, and gypsum board manufacturing. In the event that markets are not available for the product, SME will deliver the ash to an on-site or off-site monofill storage facility.

Agency Responsibilities

Environmental Impact Analysis. Under MEPA, MDEQ is responsible for preparing an environmental assessment (EA) or EIS for the HGS prior to taking state action on permits or licenses. The decision to prepare an EIS rather than an EA depends on whether or not MDEQ anticipates possible significant impacts from the implementation of the proposed project. SME's application to RUS for long term financing for the project triggered a requirement for environmental analysis under the National Environmental Policy Act (NEPA). Since RUS has determined it needs to prepare an EIS, MDEQ will work with RUS to prepare a joint EIS for HGS. The joint EIS will address both NEPA and MEPA requirements.

MDEQ is holding a public meeting and will collect comments during a 30-day public comment period on the permits and licenses that SME would need to implement its proposed power plant. RUS held a public meeting and received comments during its public scoping period in the fall of 2004. The agencies will consider all comments received by RUS as well as MDEQ in preparing the draft and final EIS. Significant or key issues, based on comments obtained during scoping, will drive the development of suggested alternatives and mitigations to address impacts relative to those issues.

Once the draft EIS is completed, it will be released for public review and comment. RUS and MDEQ will consider all substantive comments on the document and the analyses in it when completing the final EIS. After the release of the final EIS, RUS and MDEQ will issue Records of Decision jointly or in separate documents.

Permits, Approvals and Licenses. MDEQ administers the state environmental regulatory programs likely to be triggered by the HGS project. Environmental permits expected to be required for HGS include air quality, water quality and potentially, solid waste. In addition, a number of other state and federal permits and licenses may be triggered, such as the Major Facility Siting Act (MFSA) for the transmission tie-line, and stream bank permits for the water intake and discharge points along the Missouri River.

- *Air Quality Permits* - HGS will require a preconstruction air quality permit from MDEQ prior to initiating construction of the facility. The preconstruction permit will need to address permitting requirements of the federal Prevention of Significant Deterioration (PSD) regulations along with state regulations. In addition to a preconstruction permit, HGS will require an Air Quality Operating Permit from MDEQ. These permits would specify the BACT emission limits determined by MDEQ along with monitoring and recordkeeping requirements.

The acid rain regulations require that all new generation facilities greater than 25 MW apply for an Acid Rain Permit from Environmental Protection Agency (EPA) 24 months prior to operation of the generation unit. The acid rain program uses an “allowance” system to limit nationwide emissions of SO₂ from generating facilities. One allowance is equivalent to one ton per year of SO₂ emissions. HGS would purchase a sufficient number of allowances on the open market to equal its annual SO₂ emissions. In addition to SO₂, the acid rain regulations regulate emissions of NO_x from generation facilities. HGS would be subject to the more stringent NO_x emissions limit, established either through acid rain requirements or through a BACT analysis conducted for the PSD permit.

At the request of MDEQ, SME is currently collecting baseline ambient air quality monitoring data for the two preferred sites near Great Falls. Once adequate baseline monitoring data is collected, SME will incorporate the data into the air quality preconstruction permit application for review by MDEQ. An Operating Permit Application and an Acid Rain Permit application will be submitted at the same time as the Montana Air Quality Permit Application.

- *Water Quality Permits* - SME anticipates applying for a Montana Pollutant Discharge Elimination System (MPDES) permit for a discharge of plant wastewater to surface water. The anticipated discharge would be to the Missouri River. SME is finalizing water management alternatives and will submit the possible alternatives and a water management plan along with an MPDES permit application for review by MDEQ. The permit and plan would describe the water quality limits for the wastewater discharge and the methods of wastewater treatment and routing to the disposal point.

In addition to the MPDES discharge permit, SME anticipates applying to MDEQ for authorization to discharge storm water from the HGS plant site both during construction and operation. A storm water permit application and accompanying Storm Water Pollution Prevention Plan would be required for the facility. This permit and plan would describe how SME would route and control storm water runoff and runoff from the proposed HGS site.

Depending upon a review of alternatives for ash re-use and disposal, a Montana Groundwater Pollution Control System (MGWPCS) permit application may be submitted for an ash monofill on the power plant site. If required, a MGWPCS application would be submitted in the same time frame as the MPDES application. The MGWPCS permit would specify the water quality limits for the discharged water and water quality monitoring requirements.

- *Solid Waste Permits* - Depending on which alternative(s) are chosen for waste management at HGS, a solid waste permit application may be required. This permit would principally address the disposal of ash from the burned coal. Timing of this application is dependent on an alternatives analysis, but would fall in line with water permit applications discussed above.

- *Other Permits, certifications, licenses, plans, and approvals* - A number of other state and federal environmental permits, certifications, licenses, plans, and approvals may be triggered by HGS, including the following:
 - MFSA: If the transmission tie-line from the facility to the Great Falls Substation meets MFSA criteria, a certification will be required for the line.
 - State 401 Water Quality Certification for other Federal Permits or Licenses: Federal water permitting activities for the project requires certification by state under section 401 of the federal Clean Water Act. This may be required for the construction activity associated with water supply or discharge facilities.
 - Montana Streambed and Land Preservation Act, 310 Permit: Activities that physically alter or modify the bed or banks of a perennial stream need a 310 permit. This permit may be required due to the construction activity associated with the intake and/or the discharge structures.
 - Montana Floodplain and Floodway Management Act, Floodplain Development Permit: This state permit is required for project that would place fill or construct structures within a 100-year floodplain. This permit may be required due to the construction activity associated with the water supply or discharge facilities.
 - Short Term Water Quality Standard for Turbidity, 318 Authorization: Construction activities causing short-term violations of water quality standards require a 318 authorization from MDEQ. This authorization may be required due to the construction activity associated with the intake and/or the discharge structures.
 - Public Water Supply and Septic System design review: The permanent work force anticipated at the plant would require an MDEQ review of the design of the water supply and a county review of septic system for disposal of sanitary wastes.
 - Federal Clean Air Act Risk Management Plan (RMP): The proposed use, handling or storage of specified quantities of chemicals identified in the Act on the site triggers the requirement for this federal plan. Specifically, a plan will be developed for the use and storage of ammonia and submitted to EPA as required by federal regulations.
 - Federal Clean Water Act, Section 404 Permit: The Corps of Engineers requires this permit for dredging or fill activity in or along streams or wetlands. This permit may be required due to the construction activity associated with the water intake and/or the water discharge structures.
 - Federal Rivers and Harbors Act, Section 10 Permit: This permit is required by the Corps of Engineers for construction of any structure in or over federally listed navigable waters. This permit may be triggered due to the construction activity associated with the intake or discharge structures.
 - Federal Clean Water Act 316(b), Cooling Water Intake Structure requirements: The design and placement of intake structures in water bodies must meet these requirements to minimize impacts on aquatic life. The design for these structures may be reviewed and approved by MDEQ.

Submittal of Comments

Persons wanting to submit comments or concerns about the proposed project and its related state permits may submit those comments in writing to MDEQ by mail or through e-mail to the addresses listed below. All comments must be post dated by May 6, 2005.

Kathleen Johnson, MEPA Project Coordinator
Re: Highwood Generating Station EIS
Montana Department of Environmental Quality
PO Box 200901
Helena, MT 59602-0901

katjohnson@mt.gov

Figure 1: SME Service Area

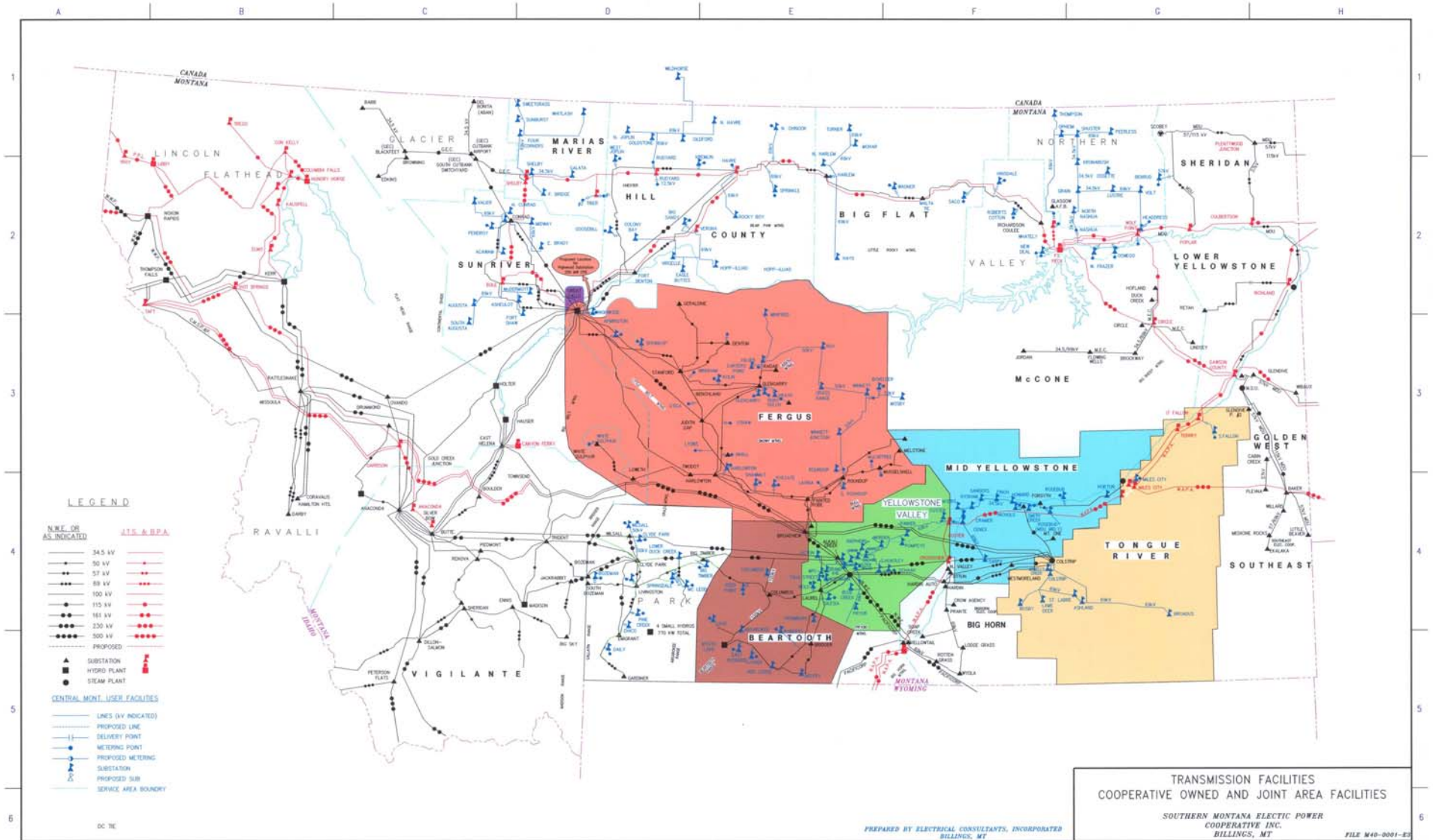

Figure 2: Highwood Station Unit 1

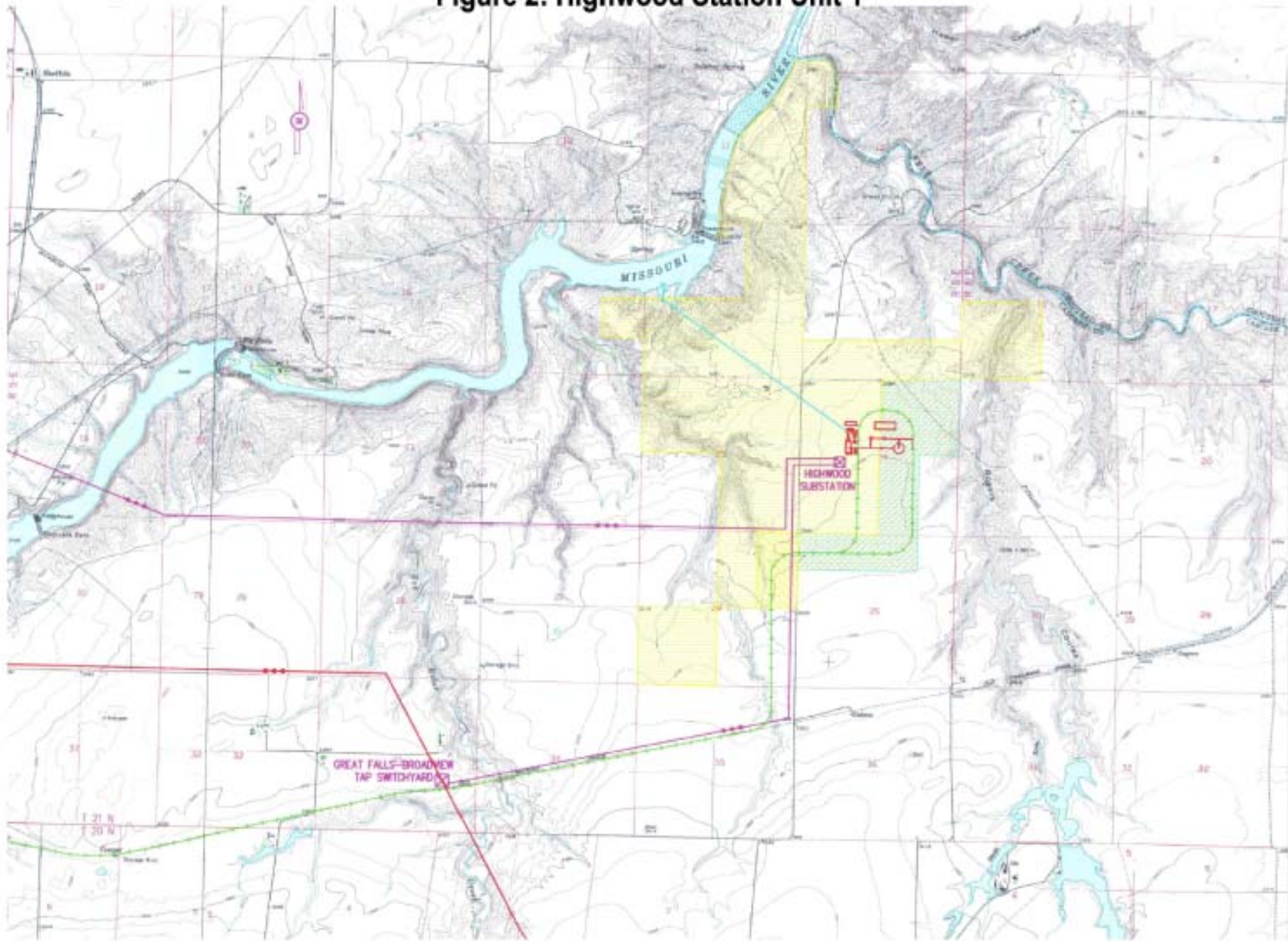
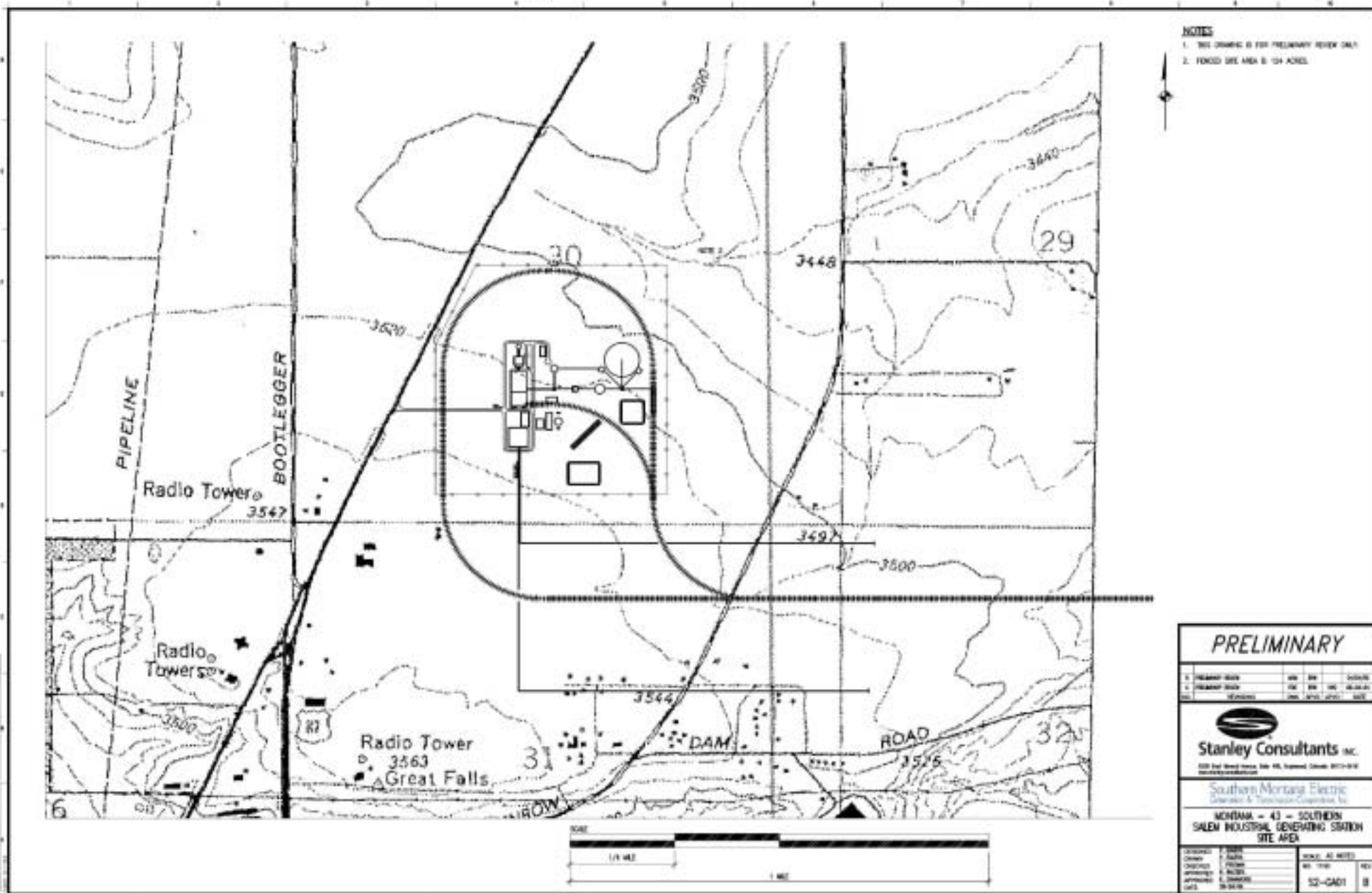

Figure 3: Industrial Park Site



- NOTES**
1. THIS DRAWING IS FOR PRELIMINARY REVIEW ONLY.
 2. FENCED SITE AREA IS 124 ACRES.

PRELIMINARY

1. PRELIMINARY DATE	REV	BY	DATE
2. PRELIMINARY DATE	REV	BY	DATE
3. PRELIMINARY DATE	REV	BY	DATE

Stanley Consultants inc.
200 East Broad Street, Suite 400, Helena, Montana 59701-9919

Southern Montana Electric
Generator & Transmission Corporation, Inc.
MONTEANA - 43 - SOUTHERN
SALEM INDUSTRIAL GENERATING STATION
SITE AREA

DESIGNED	DATE	SCALE	AS NOTED
DRAWN	DATE	BY	DATE
CHECKED	DATE	BY	DATE
APPROVED	DATE	BY	DATE
DATE	DATE	DATE	DATE

S2-CAD1

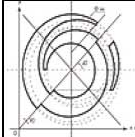

CFB Process Schematic with FDA



Copyright ALSTOM Power

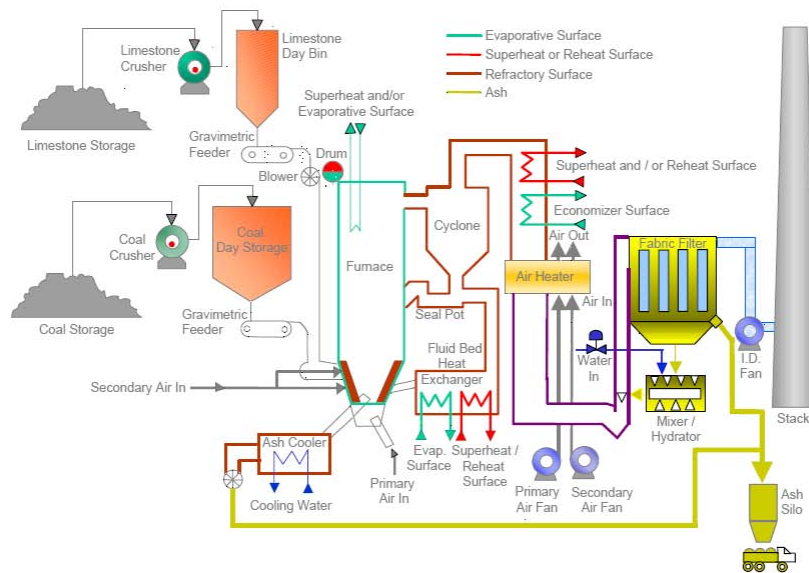

Figure 4: CFB Process