

# The Sampling Oscilloscope as a Microwave Instrument

*Dylan Williams, Paul Hale,  
and Kate A. Remley*

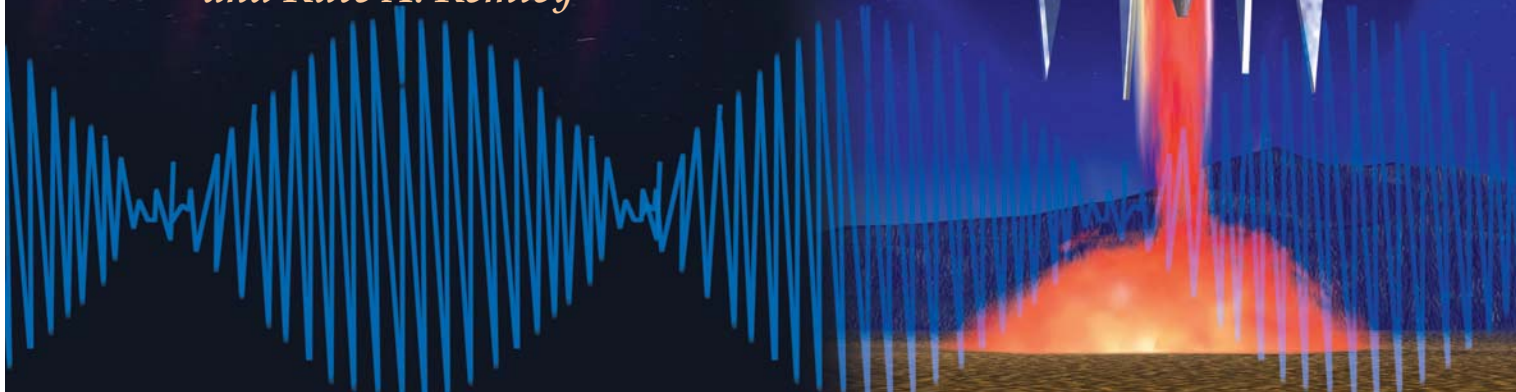

© DIGITALSTOCK

Many modern high-speed oscilloscopes are well suited for precise measurements of microwave waveforms, modulated signals, and non-linear phenomena. These oscilloscopes have bandwidths up to 100 GHz and are available with nominal 50- $\Omega$  input impedances. Like their low-frequency counterparts, these oscilloscopes are flexible, easy to use, and relatively inexpensive; this makes them ideal for testing a wide variety of microwave sources and other microwave components.

As with all microwave instruments, characterizing and correcting for the oscilloscope's imperfections are key to making accurate measurements. Important imperfections in high-speed sampling oscilloscopes include jitter, drift, and distortion in the oscilloscope's timebase, as well

as imperfections in the impulse response of the oscilloscope's sampling circuitry and the oscilloscope's impedance match. With suitable corrections, however, these high-speed sampling oscilloscopes can be used not only to debug circuits but also to perform metrology-grade measurements at the highest microwave frequencies. Most of the equipment required is readily available in most microwave labs: a vector network analyzer, a microwave signal generator, and, of course, a sampling oscilloscope! Here, we summarize many of the corrections discussed in [1] and [2] that are necessary for metrology-grade measurements and illustrate the application of these oscilloscopes to the characterization of microwave signals (see "Comparison of Microwave Signal Measurement Methods" and "Measurement of RF Power and Modulation Envelope").

---

*Dylan Williams (dylan@boulder.nist.gov), Paul Hale, and Kate A. Remley are with National Institute of Standards and Technology (NIST), Boulder, Colorado, USA.*

*Digital Object Identifier 10.1109/MMM.2007.900110*

## Types of Digital Oscilloscopes

The first oscilloscope that you used may have been an analog instrument. However, modern oscilloscopes generally process, store, and display information digitally [3]. Modern digital oscilloscopes are sold with widely varying features, but the microwave engineer can roughly group these instruments into two categories based on their internal operation: real-time oscilloscopes and sampling (or equivalent-time) oscilloscopes.

## Many modern high-speed oscilloscopes are well suited for precise measurements of microwave waveforms, modulated signals, and nonlinear phenomena.

Real-time oscilloscopes repetitively sample a waveform at a high rate and store the measurements in a circular memory buffer. By setting trigger events, the user can determine which part of the waveform to view. Trigger events might be limited to simple edge triggers in lower-end models, but higher-end models can use sophisticated digital processing to trigger on anomalous events in complicated digital or microwave signals.

General-purpose real-time oscilloscopes typically have a high input impedance and are designed to non-invasively measure voltages inside operating electrical circuits in real time. Due to parasitics in the input circuitry, the bandwidth of these oscilloscopes is limited to about 500 MHz. High-end real-time oscilloscopes circumvent this bandwidth limitation by embedding the sampling circuitry in a 50- $\Omega$  transmission line terminated in a 50- $\Omega$  load. These high-end real-time oscilloscopes achieve bandwidths comparable to those of low-end sampling oscilloscopes; they can be connected directly to the output port of a microwave circuit and

measure the voltage that the circuit generates across the oscilloscope's nominal 50- $\Omega$  input impedance. This approximates the matched environment in which most microwave components and circuits are designed to operate.

Real-time oscilloscopes use an interleaved analog-to-digital converter technology to achieve sampling rates as high as 50 Gsamples/s and bandwidths as high as 20 GHz. Real-time oscilloscopes are often capable of acquiring tens or hundreds of millions of samples and can process these waveforms to obtain information on various properties of the signal, including jitter or microwave modulation.

Although real-time oscilloscopes are extremely versatile, they also have some properties that can limit their utility for microwave applications. For example, real-time oscilloscopes use high-speed analog-to-digital converters and must move huge amounts of data into and out of memory, so their resolution is typically limited to 8 b. Also, it is difficult to perfectly match the gain, response, and delay of the different interleaved analog-to-digital converters, which reduces fidelity and limits bandwidth.

## High-Speed Sampling Oscilloscopes

High-speed sampling oscilloscopes, which will be the focus of the remainder of this article, use an equivalent-time sampling strategy to achieve useful bandwidths as high as 100 GHz. Most of these have a nominal 50- $\Omega$  input impedance and are designed to measure repetitive input signals. The use of equivalent-time sampling allows for greater fidelity than is possible in real-time oscilloscopes.

Figure 1 shows a schematic of a high-speed sampling oscilloscope. After being triggered, the oscilloscope uses a programmable delay generator to momentarily close the switch. This samples the voltage at the oscilloscope's input. The net charge that moves through the closed switch to the hold capacitor is proportional to the voltage at the oscilloscope's input when the switch closes. A sensitive amplifier and analog-to-digital converter are then used to measure this charge and thus the voltage that was present at the oscilloscope's input when the switch was closed.

The switches in a sampling oscilloscope are typically constructed with fast sampling diodes and are "opened" and "closed" by fast electrical strobe pulses. These strobe pulses momentarily place the normally reverse-biased (off) sampling diodes into a conductive forward-biased (on) state. Most modern sampling oscilloscopes

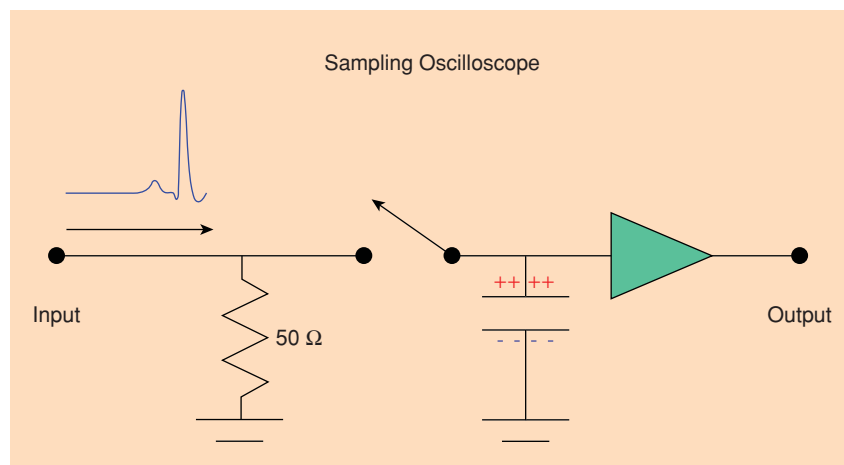

Figure 1. The operation of a sampling oscilloscope.

## Waveform Calibration Services at NIST

Accurately characterizing high-speed electrical waveforms from fundamental principles is a major challenge. NIST has developed a sophisticated electro-optic sampling system to perform these fundamental electrical measurements (see "NIST Electro-Optic Sampling System"). This electro-optic sampling system is, in essence, a very fast sampling oscilloscope based on electro-optic interactions. The electro-optic sampling systems at NIST, NPL, and PTB have measurement bandwidths of many hundreds of gigahertz. (At lower frequencies, the "nose-to-nose" calibration is sometimes used to calibrate sampling oscilloscopes [16], [23]. However, the assumptions concerning the equivalence of a sampler's kickout pulses and impulse response break down at higher frequencies [24].)

Figure 2 illustrates the traceability chain currently used at NIST. Photodiodes calibrated on NIST's electro-

optic sampling system are used to calibrate the magnitude and phase response of the oscilloscopes [14]. In principle, calibrated power meters could be used to improve the characterization of the magnitude response of the oscilloscope, but NIST uses them only to set the overall magnitude scaling of the oscilloscope calibration. The calibrated oscilloscopes are used to characterize pulse sources, step sources, comb generators [18], [25], microwave mixers [26], and modulated microwave sources [2], [20], [27]. These can, in turn, be used to calibrate a variety of instruments, including other oscilloscopes, vector signal analyzers, microwave receivers, LSNAs, and peak power meters [27].

NIST's waveform calibration services are ideally suited for microwave applications. NIST provides calibrated photodiodes and will calibrate oscilloscope plug-ins and pulse sources for a fee. NIST performs mismatch corrections on all measurements

and provides reflection coefficients of oscilloscopes and sources. This makes it possible to fully mismatch correct microwave measurements performed with oscilloscopes calibrated at NIST and allows users of these services to develop complete Thévenin equivalent circuits for sources calibrated at NIST. NIST also provides covariance matrices to describe the uncertainties in most measurements (see "Representing Uncertainties with Covariance Matrices"). This allows uncertainties to be expressed in either the temporal or frequency domains.

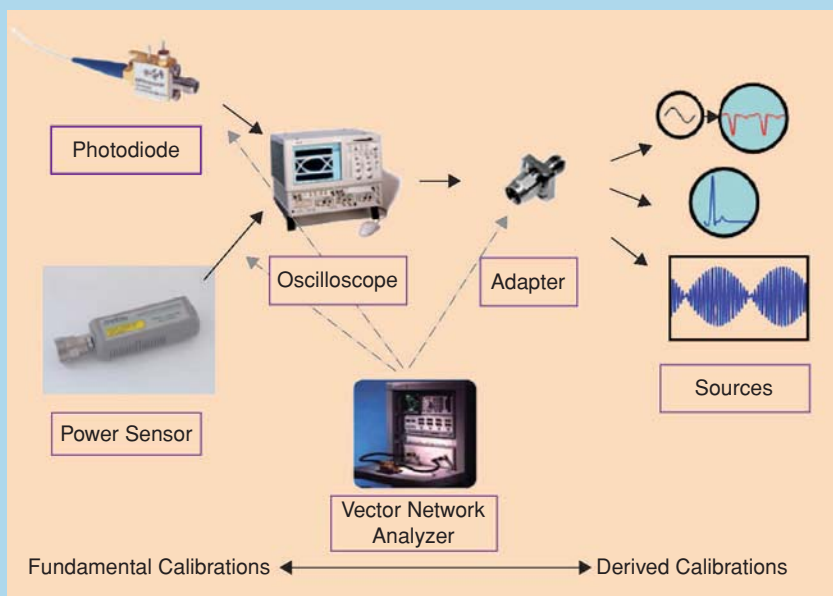

Figure 2. The NIST waveform traceability chain.

use nonlinear transmission lines to sharpen these strobe pulses and can "open" and "close" the diode switches in the sampling gates in roughly 2–20 ps. This, combined with an accurate timebase, allows the sampling oscilloscope to measure the voltage at the input of the oscilloscope very precisely in time.

### Oscilloscope Timebase

It usually takes a few microseconds or more for a sampling oscilloscope to acquire a voltage sample; this restricts sampling oscilloscopes to the measurement of repetitive signals. The typical measurement strategy used to measure a waveform is called "equivalent time sampling." In this measurement approach, the signal is

repeated over and over, and the oscilloscope's timebase is configured to close the switch just a little bit later in each cycle of the signal. Each repetition of the signal allows a new sample to be taken, adding an additional voltage sample to the measured waveform.

### Types of Oscilloscope Timebases

There are three basic classes of oscilloscope timebases, with a number of variations: conventional triggered timebases, synchronized timebases, and a hybrid timebase [4] that marries some of the best attributes of the first two.

Conventional oscilloscope timebases use trigger circuits and a programmable delay generator to time the acquisition of voltage samples [5], [6]. These timebases

are extremely flexible and easy to use, though they are prone to jitter and timebase distortion.

Synchronized timebases use an oscillator locked to, and slightly offset from, a reference signal from the source. Many microwave engineers may be familiar with the implementation of this timebase in microwave transition analyzers and sampling down-converters. These timebases are more costly and less flexible because they can only lock to and trigger on periodic signals. On the other hand, they are also less susceptible to jitter and drift, virtually eliminate timebase distortion, and sample more quickly than conventional timebases.

The hybrid approach [4], [7] uses a conventional trigger with programmable delay generator to take samples, but simultaneously measures a set of reference sinusoids that are synchronized with the signal being acquired to correct the oscilloscope's timebase.

This allows simultaneous correction for jitter, drift, and timebase distortion in a number of less-expensive conventionally triggered oscilloscopes (see "NIST Timebase Correction Software").

### Jitter, Drift, and Timebase Distortion

Imperfections in the oscilloscope's timebase include jitter (the random component of the error in the time at which the oscilloscope samples voltages), drift (a slow drift in the timebase between successive measurement sweeps), and timebase distortion (a systematic and repeatable distortion in the oscilloscope's timebase). The amount of jitter and drift depend greatly on the triggering scheme employed and usually are very tightly linked to the hardware.

Timebase distortion typically depends on the oscilloscope's internal clocks and does not depend on the triggering scheme employed. Vandersteen et

### NIST Electro-Optic Sampling System

Figure 3 sketches NIST's electro-optic sampling system [28]–[30]. The mode-locked fiber laser emits a series of short optical pulses approximately 100 fs in duration that are split by the beam splitter into an optical "excitation beam" and an optical "sampling beam." The optical excitation beam excites the photodiode, which generates a fast electrical pulse measured by the system. This electrical pulse is coupled by the wafer probe onto a coplanar waveguide (CPW) fabricated on an electro-optic substrate.

The optical sampling beam is used to reconstruct the repetitive electrical waveform generated by the photodiode at the on-wafer reference plane in the CPW. This is

done by passing the sampling beam through a variable optical delay, polarizing it, and then passing it through one of the gaps of the CPW. Since the substrate is electro-optic, the electric field between the CPW conductors changes the polarization of the optical sampling beam passing through it. The polarization analyzer detects this change, which is proportional to the voltage in the CPW at the instant at which the optical pulse arrived there. This process does not perturb the electrical signal on the CPW. Changing the delay of the sampling beam allows us to map out the voltage at the reference plane in the CPW as a function of time.

The final step in the calibration is to use vector network analysis to characterize the photodiode and resistor reflection coefficients, as well as the scattering parameters of the probe head. These reflection coefficients and scattering parameters are used to calculate the electrical waveform at the photodiode's coaxial connector. Despite the high accuracy of the network analyzer, these reflection coefficients and scattering parameters are some of the largest sources of uncertainty we have been able to identify in these measurements.

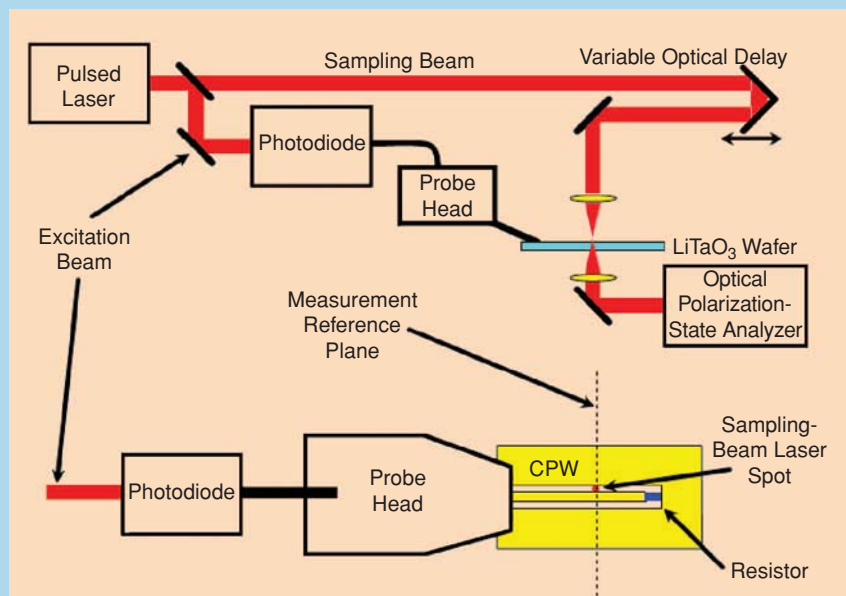

Figure 3. Sketch of NIST's electro-optic sampling system.

al. [8], Rolain et al. [9], Stennbakken et al. [10], and Wang et al. [11] pioneered modern methods for measuring and correcting for timebase distortion. These are based on measuring sinusoids with the oscilloscope to characterize distortion in the oscilloscope's timebase and using deviations of the measured signals from sinusoids to infer distortion in the oscilloscope's timebase.

The hybrid method of [4] is an outgrowth of these timebase-distortion characterization methods. It measures the sinusoids in real time to simultaneously correct for jitter, drift, and timebase distortion in conventionally triggered oscilloscopes.

### Mismatch Correction

As microwave engineers know all too well, impedances are difficult to control at microwave frequencies and multiple reflections between sources and loads must be accounted for with microwave mismatch corrections if good accuracy is to be achieved. We have found vector network analyzers to be extremely useful tools for mismatch correcting oscilloscope measurements. We use network analyzers to characterize our microwave sources, adapters, and oscilloscopes to great advantage and apply mismatch corrections whenever possible. These mismatch corrections are described in greater detail in [1].

Mismatch generally results in reflections at specific points in time. Applying mismatch corrections effectively requires great accuracy in the oscilloscope's timebase to accurately measure these temporal locations. Thus, errors in the oscilloscope's timebase usually need to be corrected before mismatch corrections can be properly applied.

**Although real-time oscilloscopes are extremely versatile, they also have some properties that can limit their utility for microwave applications.**

Mismatch correcting oscilloscope measurements with vector network analyzer measurements also requires linear time-invariant behavior. The principal issue is that the vector network analyzer measures the impedance of the oscilloscope when its sampling gate is open. The oscilloscope, therefore, must be configured to close and then open its sampling gate quickly enough that reflections off the closed gate are not re-reflected off of elements external to the oscilloscope and measured by the sampling gate before it opens again. This issue is usually

### Representing Uncertainties with Covariance Matrices

Figure 4 plots the temporal impulse response of a photodiode calculated from the Fourier transform of its complex mismatch-corrected spectrum as measured on NIST's electro-optic sampling system. These data were first presented in [22]. The principal reflection from the CPW load in the electro-optic sampling system is quite large and occurs at about 400 ps, but it is not seen in Figure 4 because it has been corrected out of the measurement.

The figure also plots the uncertainty in this impulse response calculated from a covariance matrix [22]. This formulation accounts for the correlations in the frequency-domain data when it maps the frequency-domain data into the time domain. This uncertainty peaks near the maximum of the photodiode's impulse response, as expected.

Less obvious is the smaller peak in uncertainty at 400 ps. The raw measurement of the photodiode's impulse response has a large reflection at that point, which is removed almost com-

pletely by the frequency-domain mismatch correction we employ. While the mismatch correction is very effective at eliminating this artifact of the measurement system near 400 ps, imperfections in the mismatch correction nevertheless visibly raise the uncertainty there.

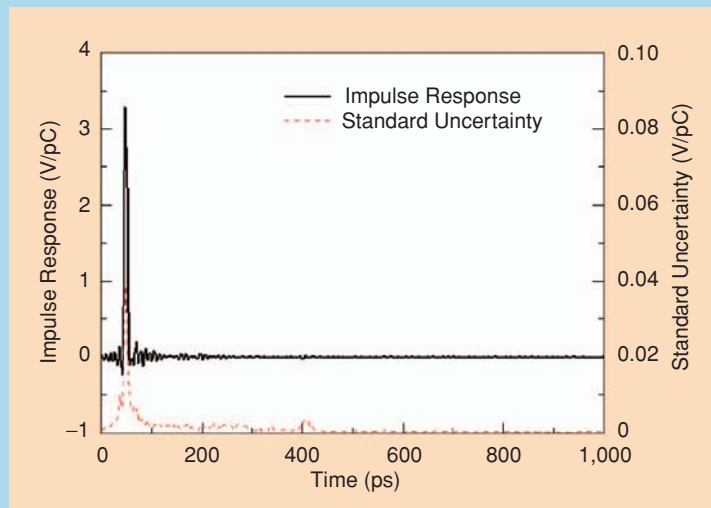

**Figure 4.** Temporal impulse response of a photodiode measured in NIST's electro-optic sampling system.

## NIST Timebase Correction Software

Imperfections in the timebase, such as jitter and timebase distortion, can cause significant measurement errors at microwave frequencies. NIST's Timebase Correction Software [31] corrects for both random and systematic timebase errors with measurements of two quadrature sinusoids made simultaneously and synchronized with the waveform being characterized. The method is described in detail in [4], and a similar implementation is presented in [7].

A typical measurement configuration for characterizing a modulated microwave signal with a sampling oscilloscope is shown in Figure 5. In the standard configuration, the oscilloscope would be triggered by the 10-MHz reference from the source and the modulated signal measured on channel 3, as shown in Figure 5. To improve the timebase, we also measure two reference sinusoids on channels 1 and 2 with the oscilloscope. Though there may be a great deal of distortion and jitter in the oscilloscope timebase, these two quadrature reference sinusoids allow the actual times at which the samples were taken to be reconstructed with great accuracy. This is because they are made simultaneously with, and synchronized to, the modulated signal measured on channel 3 of the oscilloscope.

A simple illustration of the timebase correction concept is shown in Figure 6; this plots uncorrected measurements (circles) of a reference sinusoid with an estimate of the distorted sinusoid (solid curve). The estimated sinusoid is found by minimizing the average "distance" between the samples and the sinusoid. If we assume, for illustrative purposes, that

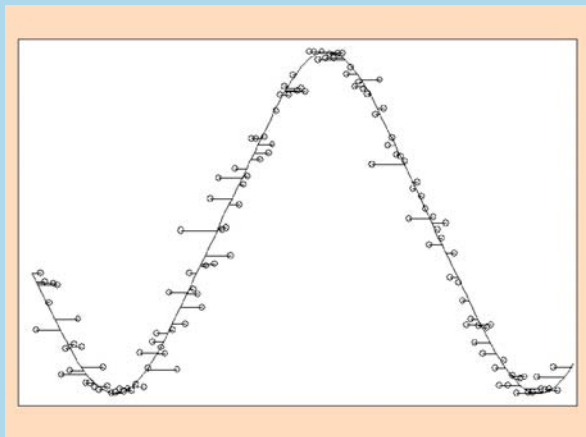

**Figure 6.** The circles show the sampled signal and the solid curve shows the estimated signal. The horizontal bars show the differences between the times estimated from the curve and the nominal oscilloscope timebase. (From [4].)

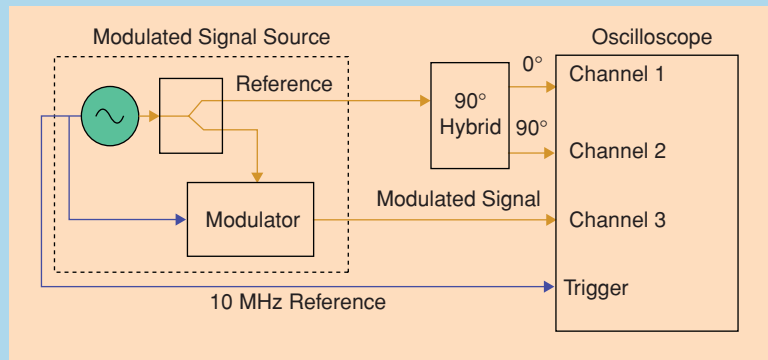

**Figure 5.** A typical measurement configuration used for characterizing a modulated signal with the NIST's Timebase Correction Software [31].

there is no additive noise, we can estimate the total error due to timebase distortion and jitter by drawing a horizontal line between each measurement (circles) and the distorted sinusoid. The length of each line represents the difference between the nominal (oscilloscope) time at which the measurement was taken and the time as determined by the distorted sinusoidal fit. The time at which each line intersects the distorted sinusoid is the corrected time for each sample.

Figure 7 shows an actual measurement of a sinusoid measured simultaneously with two reference sinusoids (not shown) that were used to calculate the timebase error. The estimated jitter before the correction was about 3.3 ps, and the effects of timebase distortion are clearly visible at 4 ns. After correction for timebase error, the residual error for this example is only about 0.2 ps.

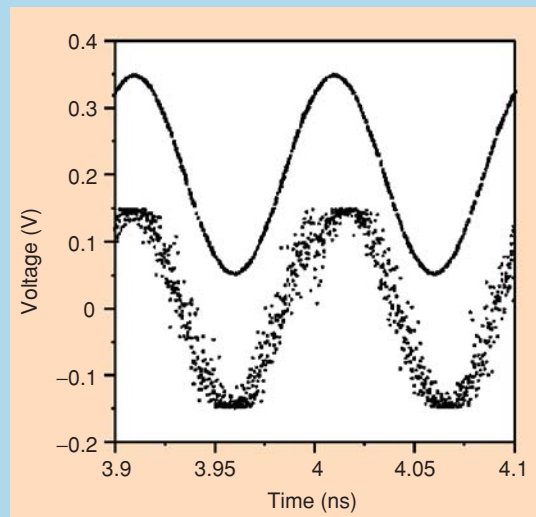

**Figure 7.** Portion of five sinusoids measured on channel 3 before (bottom) and after (top) correction for timebase errors. The offset to the corrected curve has been added for clarity. (From [4].)

## Comparison of Microwave Signal Measurement Methods

Sampling oscilloscopes have measurement bandwidths up to 100 GHz; they can be used to characterize a variety of waveforms at microwave frequencies, including pulses, modulated signals [7], [20], and signals rich in harmonics. Microwave engineers may be more familiar with instruments such as the microwave transition analyzer (MTA) and the LSNA [12], [13], which were developed specifically to acquire waveforms rich in harmonics while preserving the magnitude and phase relationships between harmonic-frequency components [2]. In fact, the phase references for an LSNA are usually characterized by calibrated sampling oscilloscopes (see “Waveform Calibration Services at NIST”).

While the LSNA and MTA are often used to characterize harmonic distortion created by nonlinear circuits such as power amplifiers, they are also capable of characterizing waveforms such as the 1-GHz square-wave pulse train shown in Figure 8. Because these instruments employ temporal measurements, they are able to measure both the magnitude and phase of modulated microwave signals. Figures 9 and 10 show the frequency-domain magnitude and phase measured by the three instruments.

The measurements of the waveform’s harmonics made by the LSNA, MTA, and oscilloscope are in good agreement. The agreement between the oscilloscope and the LSNA measurements is better than the agreement with the MTA at the higher harmonics. One of the advantages of using an LSNA is that it automatically mismatch corrects its measurements. For the scope measurements used in this comparison, we carried out timebase distortion and impulse response correction of the scope, but did not carry out mismatch correction.

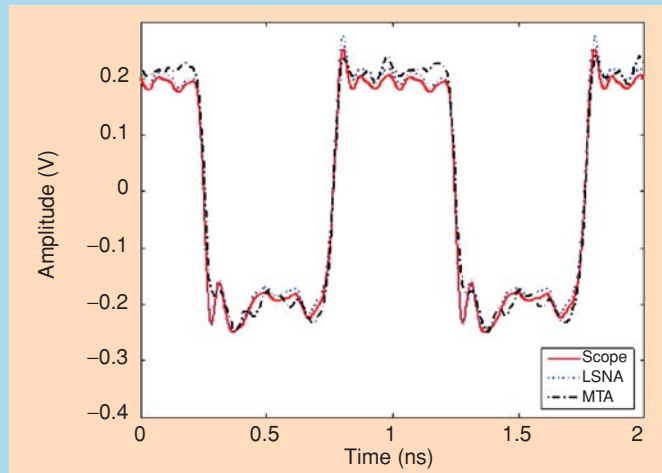

Figure 8. Comparison of the temporal waveform measurements.

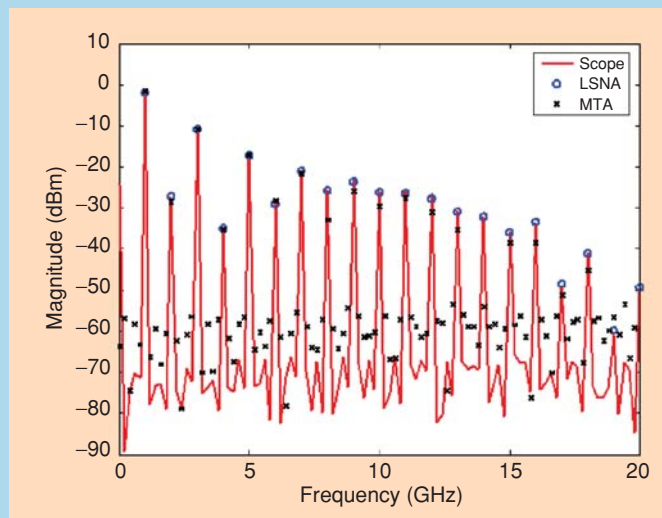

Figure 9. Comparison of magnitude measurements.

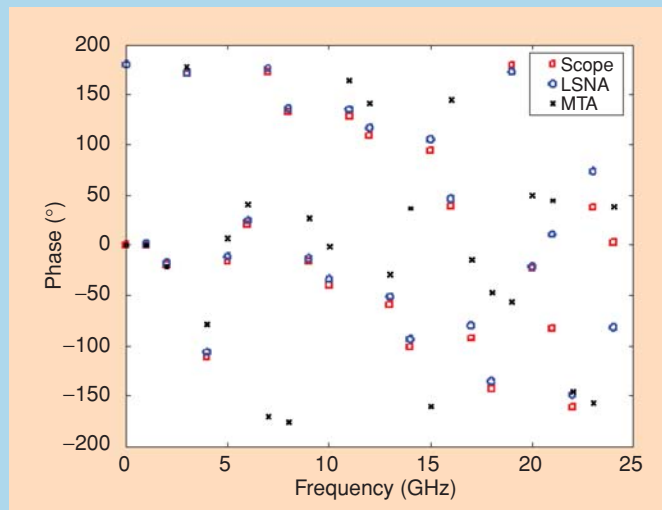

Figure 10. Comparison of phase measurements.

resolved by designing in short lengths of transmission line in the oscilloscope's front end. This constraint is discussed in greater detail in [1].

The large-signal network analyzers (LSNA) [12], [13] can be looked at as a sort of hybrid oscilloscope

## One of the best reasons to use a high-speed sampling oscilloscope in your work is its ability to quickly, accurately, and inexpensively acquire and display detailed temporal waveforms at microwave frequencies.

and network analyzer that combines the functionality of the two. Like a network analyzer, an LSNA uses couplers and multiple sampling circuits to allow for simultaneous measurement of the forward and backward waves at each port and to perform mismatch corrections there. The samplers themselves are configured to perform temporal measurements of the large-

signal waveforms, which may be distorted, at these ports. In fact, very early versions of the LSNA were constructed with microwave couplers and sampling oscilloscopes.

### Impulse-Response Characterization

Even the fastest high-speed sampling oscilloscopes have an impulse response of finite duration. The oscilloscope measures a convolution of the input signal and this impulse response. The oscilloscope's impulse response must be characterized and deconvolved to perform the most accurate measurements [1], [14]. This problem presents the most fundamental and challenging aspect of the calibration of high-speed oscilloscopes.

The National Physical Laboratory (NPL) in the United Kingdom, the Physikalisch-Technische Bundesanstalt (PTB) in Germany, and the National Institute of Standards and Technology (NIST) in the United States maintain complex measurement systems based on electro-optic sampling to characterize fast electrical pulse sources (see "NIST Electro-Optic Sampling System"). While these systems differ in the details of their construction and application, the key idea is to exploit the extremely high speed of certain

### Measurement of RF Power and Modulation Envelope by David Humphreys

Sampling oscilloscopes can measure the modulation envelope of RF signals; these signals can be used to calibrate wideband RF power meters. Modulated signals can be measured directly (see "Comparison of Microwave Signal Measurement Methods" and [7] and [20]), or the oscilloscope can be triggered on the modulation envelope so that the underlying RF signal appears as random samples.

Triggering on the modulation envelope simplifies the measurement setup. In this approach, the variance of the measured samples is proportional to the RF power in the envelope [27], and the modulation envelope and power can be determined from the statistics of the samples. This approach is closely related to that used in swept-sine oscilloscope calibrations [15]–[19].

Figure 11 illustrates the procedure. The signal from the source is modulated with a 9- $\mu$ s-long rectangular pulse. While the exact amplitude

and phase cannot be determined from the statistics of the signal, the modulation envelope and power can be determined from the variance of the measured samples. This has been applied to the calibration of microwave peak power meters at NPL in the United Kingdom [27].

*David Humphreys is with the National Physical Laboratory, Teddington, U.K.*

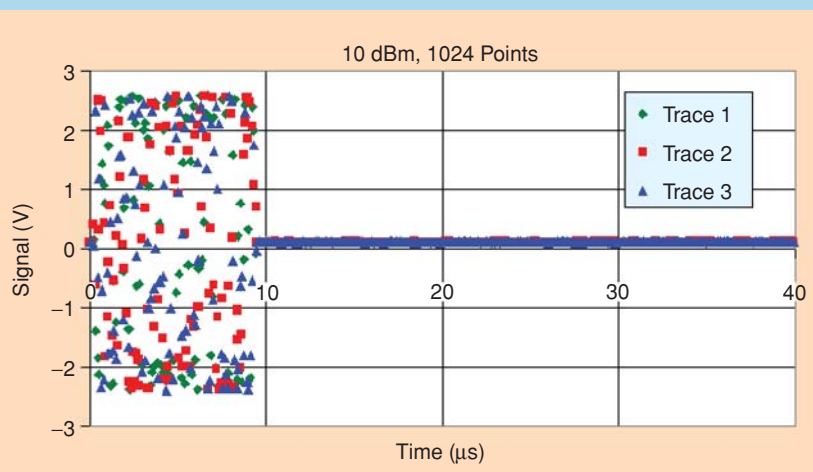

**Figure 11.** Measuring the RF power envelope through use of a sampling oscilloscope.



electro-optic interactions to characterize fast electrical reference pulses. These reference pulses can then be used to characterize the impulse response of even the fastest oscilloscopes (see “Waveform Calibration Services at NIST”).

Sometimes these electro-optic sampling systems are augmented by “swept-sine” amplitude calibrations based on measurements of sinusoids with known amplitudes. These amplitude-only calibrations can be made traceable to extremely accurate calorimetric power measurements [15]–[19].

### **Other Oscilloscope Imperfections**

In our laboratory, we usually correct for imperfections in the oscilloscope’s timebase, impulse response, and input impedance. These are not the only imperfections to watch out for.

#### ***Nonlinear Response***

Nonlinearity in the oscilloscope’s sampling circuitry is difficult to characterize and correct for. The most straightforward approach to dealing with this problem is to limit the amplitude of the input signals to the oscilloscope so that they do not exceed about 150 mV and to use averaging to increase the dynamic range. The ability to average the measurements can be greatly improved by correcting for jitter, drift, and timebase distortion before averaging, though this usually requires external processing of the data. We are able to achieve a dynamic range of about 60 dB in our laboratory when we use timebase correction software.

#### ***Strobe Leakage***

A portion of the strobe pulse used to switch the sampling diodes into forward conduction and close the sampling gate is coupled out of the front end of the oscilloscope. Fortunately, the strobe leakage occurs at the same time at which the sample is taken. This does not allow the leakage signal enough time to affect the circuit being tested before the sample is taken. Strobe leakage is nevertheless undesirable and is usually minimized by the use of two or more sampling diodes in a balanced configuration. This allows for first-order cancellation of the strobe leakage from the sampling circuit.

#### ***Low-Frequency Leakage into the Sampling Circuitry***

It is difficult to completely prevent low-frequency leakage through the sampling diodes in high-speed oscilloscopes, even when they are in their reverse-biased (off) state. This leads to a phenomenon that is often referred to as “blow-by” in the industry and causes low-frequency leakage through the sampling circuit to the hold capacitor. Blow-by manifests itself as slow settling or oscillations in the oscilloscope measurements on microsecond time scales. Blow-by is

sometimes corrected for with compensation circuits in the sampling circuits themselves. Blow-by can also be corrected for by first performing a measurement with the strobe off to characterize the blow-by and then subtracting this from later measurements with the strobe activated.

### **Transformations Between Time and Frequency**

We also often need to relate the temporal waveforms directly acquired by the oscilloscope to typical microwave frequency-domain quantities, such as the amplitude and phases of the components of a modulated microwave signal [20]. This requirement arises both when performing mismatch corrections and when evaluating other aspects of signal quality, such as harmonic distortion.

## **High-speed sampling oscilloscopes use an equivalent-time sampling strategy to achieve useful bandwidths as high as 100 GHz.**

The transformations used depend on the signal type. The Fourier transform of a repetitive signal with finite power can be directly derived from a discrete numerical Fourier transform. Approximations to the continuous Fourier transform of single pulses with finite energy can be constructed from discrete numerical Fourier transforms in a similar manner. These transformations are discussed in greater detail in [1]. We have also developed a software package that simplifies these calculations [21].

Transforming measurement uncertainties between temporal and frequency-domain representations is less obvious. The transformations of uncertainties between the two domains depend greatly on how the measurements from different times or frequencies are correlated. For example, we know that white noise in one domain transforms into white noise in the other domain. The energy in an error signal that takes the form of a ripple in the frequency domain, however, tends to bunch up at a single point in time. This leads to large errors at specific temporal locations. The correlations in the uncertainties must be captured to predict how uncertainties in one domain will transform to the other domain.

To address this problem, we developed a rigorous approach that is uniquely suited to measurements of interest to the microwave community. The approach is based on using covariance matrices to represent our uncertainties and capture correlations between them [1], [22] (see [1] and “Representing Uncertainties with Covariance Matrices”).

## Start Using One Today!

One of the best reasons to use a high-speed sampling oscilloscope in your work is its ability to quickly, accurately, and inexpensively acquire and display detailed temporal waveforms at microwave frequencies. This often greatly speeds troubleshooting and lends itself to the development of an intuitive feel for what is going on in a circuit.

## Conventional oscilloscope timebases use trigger circuits and a programmable delay generator to time the acquisition of voltage samples.

With the addition of timebase, impulse response, and mismatch corrections, you can turn your high-speed sampling oscilloscope into a precision microwave instrument. For much the same reasons that we find a low-frequency oscilloscope on almost every electrical engineer's bench, perhaps the time has come to start putting high-speed sampling oscilloscopes on our microwave measurement benches!

### References

[1] D.F. Williams, T.S. Clement, P.D. Hale, and A. Dienstfrey, "Terminology for high-speed sampling-oscilloscope calibration," in *Automatic RF Techniques Group Conf. Dig.*, vol. 68, Dec. 2006, pp. 9–14.

[2] K.A. Remley and P.D. Hale, "Magnitude and phase calibrations for RF, microwave, and high-speed digital signal measurements," in *RF and Microwave Handbook*, 3rd ed. Piscataway, NJ: IEEE Press, 2007.

[3] M. Kahrs, "50 Years of RF and microwave sampling," *IEEE Trans. Microwave Theory Tech.*, vol. 51, no. 6, pp. 1787–1805, June 2003.

[4] P.D. Hale, C.M. Wang, D.F. Williams, K.A. Remley, and J. Wepman, "Compensation of random and systematic timing errors in sampling oscilloscopes," *IEEE Trans. Instrum. Meas.*, vol. 55, no. 6, pp. 2146–2154, Dec. 2006.

[5] J. Verspecht, "Calibration of a measurement system for high frequency nonlinear devices," Ph.D. thesis, Free University of Brussels, 1995.

[6] J.B. Retting and L. Dobos, "Picosecond time interval measurements," *IEEE Trans. Instrum. Meas.*, vol. 44, pp. 284–287, Mar. 1995.

[7] D.A. Humphreys, "Vector measurement of modulated RF signals by an in-phase and quadrature referencing technique," *IEE Proc. Sci. Meas. Tech.*, vol. 153, no. 6, pp. 210–216, Nov. 2006.

[8] G. Vandersteen, Y. Rolain, and J. Schoukens, "System identification technique for data acquisition characterization," *IEEE Trans. Instrum. Meas. Tech. Conf.*, vol. 2, pp. 1211–1216, May 1998.

[9] Y. Rolain, J. Schoukens, and G. Vandersteen, "Signal reconstruction for non-equidistant finite length sample sets: A 'KIS' approach," *IEEE Trans. Instrum. Meas.*, vol. 47, no. 5, pp. 1046–1052, Oct. 1998.

[10] G.N. Stenbakken and J.P. Deyst, "Timebase nonlinearity determination using iterated sine-fit analysis," *IEEE Trans. Instrum. Meas.*, vol. 47, no. 5, pp. 1056–1061, Oct. 1998.

[11] C.M. Wang, P.D. Hale, and K.J. Coakley, "Least-squares estimation of time-base distortion of sampling oscilloscopes," *IEEE*

*Trans. Instrum. Meas.*, vol. 48, no. 6, pp. 1324–1332, Dec. 1999.

[12] J. Verspecht, "Large-signal network analysis," *IEEE Microwave Mag.*, vol. 6, no. 4, pp. 82–92, Dec. 2005.

[13] W. Van Moer and Y. Rolain, "A large-signal network analyzer: Why is it needed?," *IEEE Microwave Mag.*, vol. 7, no. 6, pp. 46–62, Dec. 2006.

[14] T.S. Clement, P.D. Hale, D.F. Williams, C.M. Wang, A. Dienstfrey, and D.A. Keenan, "Calibration of sampling oscilloscopes with high-speed photodiodes," *IEEE Trans. Microwave Theory Tech.*, vol. 54, no. 8, pp. 3173–3181, Aug. 2006.

[15] D. Henderson, A.G. Roddie, and A.J.A. Smith, "Recent developments in the calibration of fast sampling oscilloscopes," *IEE Proc.-A*, vol. 139, no. 5, pp. 254–260, Sept. 1992.

[16] J. Verspecht and K. Rush, "Individual characterization of broadband sampling oscilloscopes with a nose-to-nose calibration procedure," *IEEE Trans. Instrum. Meas.*, vol. 43, no. 2, pp. 347–354, Apr. 1994.

[17] P.D. Hale, T.S. Clement, K.J. Coakley, C.M. Wang, D.C. DeGroot, and A.P. Verdoni, "Estimating the magnitude and phase response of a 50 GHz sampling oscilloscope using the 'nose-to-nose' method," in *Automatic RF Techniques Group Conf. Dig.*, vol. 55, pp. 35–42, June 2000.

[18] F. Verbeyst, "Contributions to large-signal network analysis," Ph.D. thesis, Vrije Universiteit Brussel, 2006.

[19] J.B. Scott, "Rapid millimetre-wave response characterization to well beyond 120 GHz using an improved nose-to-nose method," in *IEEE MTT-S Int. Microwave Symp. Dig.*, vol. 3, pp. 1511–1514, June 2003.

[20] K.A. Remley, P.D. Hale, D.I. Bergman, and D.A. Keenan, "Comparison of multisine measurements from instrumentation capable of nonlinear system characterization," in *ARFTG Conference Dig.*, vol. 66, pp. 34–43, Dec. 2005.

[21] D.F. Williams and A. Dienstfrey, "Fourier-transform helper," 2006 [Online]. Available: <http://www.boulder.nist.gov/dylan>

[22] D.F. Williams, A. Lewandowski, T.S. Clement, C.M. Wang, P.D. Hale, J.M. Morgan, D.A. Keenan, and A. Dienstfrey, "Covariance-based uncertainty analysis of the NIST Electro-optic Sampling System," *IEEE Trans. Microwave Theory Tech.*, vol. 54, no. 1, pp. 481–491, Jan. 2006.

[23] K. Rush, S. Draving, and J. Kerley, "Characterizing high-speed oscilloscopes," *IEEE Spectr.*, pp. 38–39, Jan. 1990.

[24] D.F. Williams, T.S. Clement, K.A. Remley, and P.D. Hale, "Systematic error of the nose-to-nose sampling oscilloscope calibration," Submitted to *IEEE Trans. Microwave Theory Tech.*, to be published.

[25] F. Verbeyst, "Commercial solutions for advanced component characterization, possibly in non-50 Ohm environments," in *Proc. 2006 Int. Microwave Symp.*, San Francisco, CA, 2006.

[26] D.F. Williams, H. Khenissi, F. Ndagijimana, K.A. Remley, J.P. Dunsmore, P.D. Hale, C.M. Wang, and T.S. Clement, "Sampling-oscilloscope measurement of a microwave mixer with single-digit phase accuracy," *IEEE Trans. Microwave Theory Tech.*, vol. 53, no. 3, pp. 1210–1217, Mar. 2006.

[27] D.A. Humphreys and J. Miall, "Traceable RF peak power measurements for mobile communications," *IEEE Trans. Instrum. Meas.*, vol. 54, no. 2, pp. 680–683, Apr. 2005.

[28] T.S. Clement, P.D. Hale, D.F. Williams, and J.M. Morgan, "Calibrating photoreceiver response to 110 GHz," in *15th Annual Meeting of the IEEE Lasers and Electro-Optics Society Conf. Dig.*, pp. 877–878, Nov. 2002.

[29] D.F. Williams, P.D. Hale, T.S. Clement, and J.M. Morgan, "Mismatch corrections for electro-optic sampling systems," in *Automatic RF Techniques Group Conf. Dig.*, vol. 56, pp. 141–145, Nov. 2000.

[30] D.F. Williams, P.D. Hale, T.S. Clement, and J.M. Morgan, "Calibrating electro-optic sampling systems," in *IEEE MTT-S Int. Microwave Symp. Dig.*, vol. 3, pp. 1527–1530, May 2001.

[31] P.D. Hale, C.M. Wang, D.F. Williams, K.A. Remley, and J. Wepman, "Time Base Correction (TBC) software package," 2005 [Online]. Available: [http://www.boulder.nist.gov/div815/HSM\\_Project/Software.htm](http://www.boulder.nist.gov/div815/HSM_Project/Software.htm)

