

## APPENDICES



# APPENDIX A

## Bibliography and Reference List

- Battan, L. J. 1980. Observations of two Colorado thunderstorms by means of a zenith-pointing Doppler radar. *Journal of Applied Meteorology*, 19: 580-592.
- Carbone, R.E., B. Foote, M. Moncrieff, T. Gal-Chen, W. Cotton, M. Hjelmfelt, F. Roux, G. Heymsfield, and E. Brandes. 1990. Convective dynamics: Panel Report. Chapter 24b of Radar in Meteorology, (Editor David Atlas). American Meteorological Society: 391-400.
- Carbone R.E. and M.J. Carpenter. 1983. Rapid scan Doppler radar development considerations Part I: Sampling requirements in convective storms. In reprint volume for the 21st Conference on Radar meteorology, American Meteorological Society, Boston MA: 278-283.
- Carbone, R.E., M.J. Carpenter, and C.D. Burghart. 1985. Doppler radar sampling limitations in convective storms, *Journal of Atmospheric and Oceanic Technology*, 2: 357-361.
- Crook, A. 1994. Numerical simulations initialized with radar-derived winds. Part I: Simulated data experiments. *Monthly Weather Review*, 122: 1189-1203.
- Crook, A., and J.D. Tuttle. 1994. Numerical simulations initialized with radar-derived Mwinds. Part II: Forecasts of three gust-front cases. *Monthly Weather Review*, 122: 1204-1217.
- Doviak, R.J. and D.S. Zrnić. 1993. *Doppler Radar and Weather Observations*, Academic Press, Orlando, FL.
- Gal-Chen, T. 1978. A method for the initialization of the anelastic equations: Implications for matching models with observations. *Monthly Weather Review*, 106: 587-606.
- Hane, C. E., and B.C. Scott. 1978. Temperature and pressure perturbations within convective clouds derived from detailed air motion information: Preliminary testing. *Monthly Weather Review*, 106: 654-661.
- Herd, J., S. Duffy, and H. Steyska. 2005. Design considerations and results for an overlapped subarray radar antenna. IEEE International Aerospace Conference, Big Sky, MT.
- IWGEO (Interagency Working Group on Earth Observations). 2005. *Strategic Plan for the U.S. Integrated Earth Observation System*. Interagency Working Group on Earth Observations, National Science and Technology Council on Environment and Natural Resources, Washington, D.C.
- JPDO (Joint Planning and Development Office). 2004. *Next Generation Air Transportation System Integrated Plan*. Joint Planning and Development Office, Washington, D.C.
- Knight, C.A., and P. Squires, Eds. 1982. *Hailstorms of the Central High Plains. The National Hail Research Experiment, Vol. 1*. National Center for Atmospheric Research in Association with Colorado Associated University Press. .
- Laroche, S. and I. Zawadzki. 1994. A variational analysis method for the retrieval of three-dimensional wind field from single-Doppler radar data. *Journal of the Atmospheric Sciences*, 51: 2664-2682.

- Laroche, S. and I. Zawadzki. 1995. Retrievals of horizontal winds from single-Doppler clear air data by methods of cross-correlation and variational analysis. *Journal of Atmospheric and Oceanic Technology*, 12: 721-738.
- Lataitis, R.J., and R.J. Doviak. 1995. Precision of spaced antenna wind estimates. In preprint volume for the 27<sup>th</sup> Conference on Radar Meteorology, Vail, CO, American Meteorological Society: 717-719.
- Levit, J.J., and K.K. Droegemeier. 1999. A simple diabatic initialization technique for storm-resolving models using NIDS Data. The 29<sup>th</sup> Conference on Radar Meteorology, Montreal, Canada, American Meteorological Society: (abstract submitted).
- Lin, Y., P.S. Ray, and K.W. Johnson. 1993. Initialization of a modeled convective storm using Doppler radar-derived fields. *Monthly Weather Review*, 121: 2757-2775.
- Mazur, V, D.S. Zrni, and W.D. Rust. 1987. Transient changes in Doppler spectra of precipitation associated with lightning, *Journal of Geophysical Research*, 92: 6699-6704.
- Mishra, P., and P. Enge. 2001. *Global Positioning System: Signals, Measurements and Performance*. Ganga-Jamuna Press, Lincoln, MA.
- NEXRAD MOA (Next Generation Weather Radar Program Memorandum of Agreement). 2004. Memorandum of Agreement among the Department of Commerce, Department of Defense, and Department of Transportation for Interagency Operation of the Weather Surveillance Radar-1988, Doppler (WSR-88D). 2 June 2004.
- NOAA (National Oceanic and Atmospheric Administration). 2003. *NOAA Long-term Research Plan Revolutionizing Tornado Warnings: Phased Array Radar*. NOAA Strategic Planning, Office of Program Planning and Integration, Silver Spring, MD.
- NOAA 2004. *New Priorities for the 21<sup>st</sup> Century NOAA's Strategic Plan Updated for FY2005 – FY2010*. NOAA Strategic Planning, Office of Program Planning and Integration, Silver Spring, MD.
- NOAA 2005. *Understanding Global Ecosystems to Support Informed Decision-Making, A 20-Year Research Vision*. NOAA Strategic Planning, Office of Program Planning and Integration, Silver Spring, MD.
- NRC (National Research Council). 2002. *Weather Radar Technology beyond NEXRAD*. Committee on Weather Radar Technology beyond NEXRAD, Board on Atmospheric Sciences and Climate, Division on Earth and Life Studies, National Research Council. Washington, D.C.: National Academy Press.
- NRC. 2004. *Where the Weather Meets the Road: A Research Agenda for Improving Road Weather Services*. Committee on Weather Research for Surface Transportation: The Roadway Environment, Board on Atmospheric Sciences and Climate, Division on Earth and Life Studies, National Research Council. Washington, D.C.: National Academy Press.
- OFCM (Office of the Federal Coordinator for Meteorological Services and Supporting Research). 2004. *Federal Research and Development Needs and Priorities for Atmospheric Transport and Diffusion Modeling*. FCM-R23-2004. Washington, D.C. [www.ofcm.gov/r23/r23-2004/fcm-r23.htm](http://www.ofcm.gov/r23/r23-2004/fcm-r23.htm).
- Rabideau, D., R. Galejs, F. Willwerth, and D. McQueen. 2003. An S-band digital array radar testbed. IEEE International Symposium on Phased Array Systems and Technology, Waltham, MA.

- Rasmussen, E.N., S. Richardson, J. M. Straka, P. M. Markowski, and D. O. Blanchard. 2000. The association of significant tornadoes with a baroclinic boundary on 2 June 1995. *Monthly Weather Review*, 128: 174–191.
- Raytheon. 1995. *Terminal Area Surveillance System (TASS) Phased Array Radar Study*. Report submitted to the Federal Aviation Administration by Raytheon Corporation.
- Shapiro, A., K. Brewster, L. Zhao, S. Weygandt, and S. Lazrus. 1996. Initial forecast fields from single-Doppler wind retrieval, thermodynamic retrieval, and ADAS. *The 11<sup>th</sup> Conference on Numerical Weather Prediction*, Norfolk, VA, American Meteorological Society: 119-121.
- Shapiro, A., P. Robinson, and J. Wurman. 2001. Single-Doppler velocity retrievals with rapid-scan radar data. In preprints volume for the 30<sup>th</sup> *International Conference on Radar Meteorology*, Munich, Germany, American Meteorological Society: 194-196.
- Shapiro, A., S. Ellis, and J. Shaw. 1995. Single-Doppler velocity retrievals with Phoenix II data: clear air and microburst wind retrievals in the planetary boundary layer. *Journal of the Atmospheric Sciences*, 52: 1265-1287.
- Serafin, R.J. 1990. Meteorological radar. Chapter 23 in M. Skolnik, ed., *Radar Handbook*, second edition. Smith, S., and R.J. Doviak. 1984. Doppler velocity bias due to beam blockage by ground targets. In preprints volume for the 22<sup>nd</sup> Conference on Radar Meteorology, Zurich, Switzerland, American Meteorological Society: 534-537.
- Sun, J., and N.A. Crook. 1994. Wind and thermodynamic retrieval from single-Doppler measurements of a gust front observed during Phoenix II. *Monthly Weather Review*, 122: 1075-1091.
- Tuttle, J.D., and G.B. Foote. 1990. Determination of the boundary layer airflow from a single Doppler radar. *Journal of Atmospheric and Oceanic Technology*, 7: 218-232.
- Weber, M., J. Cho, J. Flavin, J. Herd, M. Vai. 2005. Multi-function phased array radar for U.S. civil sector surveillance needs. 32nd International Weather Radar Conference, Albuquerque, NM. [Included as Appendix B to this report.]
- Williams E.R., S.G. Geotis, and A.B. Bhattacharya. 1989. A radar study of the plasma and geometry of lightning. *Journal of the Atmospheric Sciences*, 46: 1173-1185.
- Wolf, W.W., J. K. Westbrook, J. R. Raulston, S. D. Pair, and P. D. Lingren. 1995. Radar observation of orientation of noctuids migrating from corn fields in the Lower Rio Grande Valley. *Southwestern Entomologist*. S18: 45–61.
- Wolfson, M., C.A. Meuse. 1993. Quantifying airport terminal area weather surveillance requirements. In preprints volume for the 26<sup>th</sup> International Conference on Radar Meteorology, Norman OK, American Meteorological Society: 47-49.
- Xu, Q., C.J. Qiu, and J.-X. Yu. 1994a. Adjoint-method retrievals of low-altitude wind fields from single-Doppler reflectivity measured during Phoenix-II. *Journal of Atmospheric and Oceanic Technology*, 11: 275-288.
- Xu, Q., C.J. Qiu, and J.-X. Yu. 1994b. Adjoint-method retrievals of low-altitude wind fields from single-Doppler wind data. *Journal of Atmospheric and Oceanic Technology*, 11: 579-585.
- Xu, Q., J. Qiu, H.-D. Gu, and J.-X. Yu. 1995. Simple adjoint retrievals of microburst winds from single-Doppler radar data. *Monthly Weather Review*, 123: 1822-1833.
- Zrnica, D.S., W.D. Rust, and W.L. Taylor. 1982. Doppler radar echoes of lightning and precipitation at vertical incidence. *Journal of Geophysical Research*, 87: 7179-7191



## APPENDIX B

### **Multi-Function Phased Array Radar for U.S. Civil-Sector Surveillance Needs**





## MULTI-FUNCTION PHASED ARRAY RADAR FOR U.S. CIVIL-SECTOR SURVEILLANCE NEEDS

Mark Weber\*, John Cho, James Flavin, Jeffrey Herd, and Michael Vai  
MIT Lincoln Laboratory, Lexington, Massachusetts

### 1. INTRODUCTION

This paper is a concept study for possible future utilization of active electronically scanned radars to provide weather and aircraft surveillance functions in U.S. airspace. If critical technology costs decrease sufficiently, multi-function phased array radars might prove to be a cost effective alternative to current surveillance radars, since the number of required radars would be reduced, and maintenance and logistics infrastructure would be consolidated. A radar configuration that provides terminal-area and long-range aircraft surveillance and weather measurement capability is described and a radar network design that replicates or exceeds current airspace coverage is presented. Key technology issues are examined, including transmit-receive elements, overlapped sub-arrays, the digital beamformer, and weather and aircraft post-processing algorithms. We conclude by discussing implications relative to future national weather and non-cooperative aircraft target surveillance needs.

The U.S. Government currently operates four separate ground based surveillance radar networks supporting public and aviation-specific weather warnings and advisories, and primary or “skin paint” aircraft surveillance. The separate networks are:

- (i) The 10-cm wavelength NEXRAD or WSR88-D (Serafin and Wilson, 2000) national-scale weather radar network. This is managed jointly by the National Weather Service (NWS), the Federal Aviation Administration (FAA), and the Department of Defense (DoD).
- (ii) The 5-cm wavelength Terminal Doppler Weather Radars (TDWR) (Evans and Turnbull, 1989) deployed at large airports to detect low-altitude wind-shear phenomena.
- (iii) The 10-cm wavelength Airport Surveillance Radars (ASR-9 and ASR-11) (Taylor and Brunins, 1985) providing terminal area primary aircraft

surveillance and vertically averaged precipitation reflectivity measurements<sup>1</sup>.

- (iv) The 30-cm wavelength Air Route Surveillance Radars (ARSR-1, 2, 3 and 4) (Lay et al., 1990) that provide national-scale primary aircraft surveillance.

The latter three networks are managed primarily by the FAA, although the DoD operates a limited number of ASRs and has partial responsibility for maintenance of the ARSR network. In total there are 513 of these radars in the contiguous United States (CONUS), Alaska, and Hawaii.

The agencies that maintain these radars conduct various “life extension” activities that are projected to extend their operational life to approximately 2020. At this time, there are no defined programs to acquire replacement radars.

The NWS and FAA have recently begun exploratory research on the capabilities and technology issues related to the use of multi-function phased array radar (MPAR) as a possible replacement approach. A key concept is that the MPAR network could provide both weather and primary aircraft surveillance, thereby reducing the total number of ground-based radars. In addition, MPAR surveillance capabilities would likely exceed those of current operational radars, for example, by providing more frequent weather volume scans and by providing vertical resolution and height estimates for primary aircraft targets.

Table 1 summarizes the capabilities of current U.S. surveillance radars. These are approximations and do not fully capture variations in capability as a function, for example, of range or operating mode. A key observation is that significant variation in update rates between the aircraft and weather surveillance functions are currently achieved by using fundamentally different antenna patterns—low-gain vertical “fan beams” for aircraft surveillance that are scanned in azimuth only, versus high-gain weather radar “pencil beams” that are scanned volumetrically at much lower update rates. Note also that, if expressed in consistent units, the power-aperture products of the weather radars significantly exceed those of the ASRs and ARSRs.

---

\* This work was sponsored by the Federal Aviation Administration under Air Force Contract FA8721-05-C-0002. Opinions, interpretations, conclusions, and recommendations are those of the authors and are not necessarily endorsed by the United States Government.

*Corresponding author address:* Mark E. Weber, MIT Lincoln Laboratory, 244 Wood St., Lexington, MA 02420-9185; e-mail: [markw@ll.mit.edu](mailto:markw@ll.mit.edu).

---

<sup>1</sup> A limited number of ASR-9 are equipped with the Weather Systems Processor (Weber, 2005), which additionally provides a capability for low-altitude wind-shear detection.

	Sensitivity	Coverage		Angular Resolution		Waveform	Update Rate
		Range	Altitude	Az	EI		
Terminal Aircraft Surveillance	1 m <sup>2</sup>	60 nm	20,000'	1.4°	5.0°	>18 pulses PRI ~ 1 ms	5 s
En Route Aircraft Surveillance	2.2 m <sup>2</sup>	250 nm	60,000'	1.4°	2.0°	>10 pulses PRI ~ 3 ms	12 s
Terminal Area Weather	-20 to -5 dBz	60 nmi	15,000'	1°	1°	>50 pulses PRI ~ 1 ms	60 s
National Scale Weather	-20 to -5 dBz	250 nmi	60,000'	1°	1°	~50 pulses PRI ~ 1 ms	300 s

Table 1. Summary of current U.S. surveillance radar capabilities.

In the next section, we present a concept design for MPAR and demonstrate that it can simultaneously provide the measurement capabilities summarized in Table 1. In Section 3 we present an MPAR network concept that duplicates the airspace coverage provided by the current multiple radar networks. Section 4 discusses technology issues and associated cost considerations. We conclude in Section 5 by discussing implications relative to future national weather and non-cooperative aircraft target surveillance needs.

## 2. RADAR DESIGN CONCEPT

### 2.1 Antenna Configuration and Scan Patterns

Four antenna faces are assumed so that azimuth scanning of  $\pm 45^\circ$  is required. The angular resolution and power-aperture requirements of the weather function drive the size of each face. To compensate for beam squinting, a broadside beamwidth of  $0.7^\circ$  is needed. Roughly 20,000 elements per face would be required and, at S-band, an 8-m diameter circular aperture (50 m<sup>2</sup>). Antenna gain would be 46 dB or greater depending on scan angle. We assume each transmit-receive (TR) module can provide 10-W peak power, thus providing 200 kW total for the array.

Three different surveillance functions (terminal aircraft, en route aircraft, and weather) are assigned to separate frequency channels. These frequencies are within the same band, but are separated sufficiently that pulse transmission, reception, and processing can be accomplished independently. Pulse transmissions for the three functions will not be synchronized. Thus, isolated “dead gates” will be introduced into the coverage volumes of each function when energy is transmitted for one of the other functions. It is assumed that these blanked gates will

shift around on successive volume updates so as to minimize operational impact. Figure 1 illustrates the pulse transmission sequence.

We show below that transmission of 5  $\mu$ s, 200-kW peak-power pulses provides sufficient energy on target to realize the weather and en route aircraft surveillance functions. Five-to-one pulse compression is assumed to maintain the ~150-m range resolution of current surveillance radars. For the terminal aircraft surveillance function, a 1- $\mu$ s uncoded pulse provides sufficient energy on target. This pulse can also be used as a “fill pulse” to measure weather at very short ranges.

The separate frequency channels allow for the formation of independent transmit beams and receive beam clusters separately for the different functions. High angular resolution can be maintained for all surveillance functions by using the full aperture for receive beam formation. Where needed, rapid volume scanning can be achieved by dynamically widening the transmit beam pattern so as to illuminate multiple resolution volumes concurrently.

Figure 2 depicts notional transmit and receive beam patterns appropriate for the various surveillance modes. Digital control and processing of the TR-elements is needed to generate these independent beams. Since, at any one time, the receive beams are clustered in relatively small angular intervals, an overlapped sub-array beamforming architecture (Herd et al., 2005) with digitization at the sub-array level can be used. As seen from Figure 2, the maximum number of concurrent beams in our concept is approximately 200, which sets a lower limit on the number of sub-arrays. For specificity, we will assume that 400 sub-array channels will be digitized to support synthesis of low-sidelobe (< 40 dB) receive beam patterns.

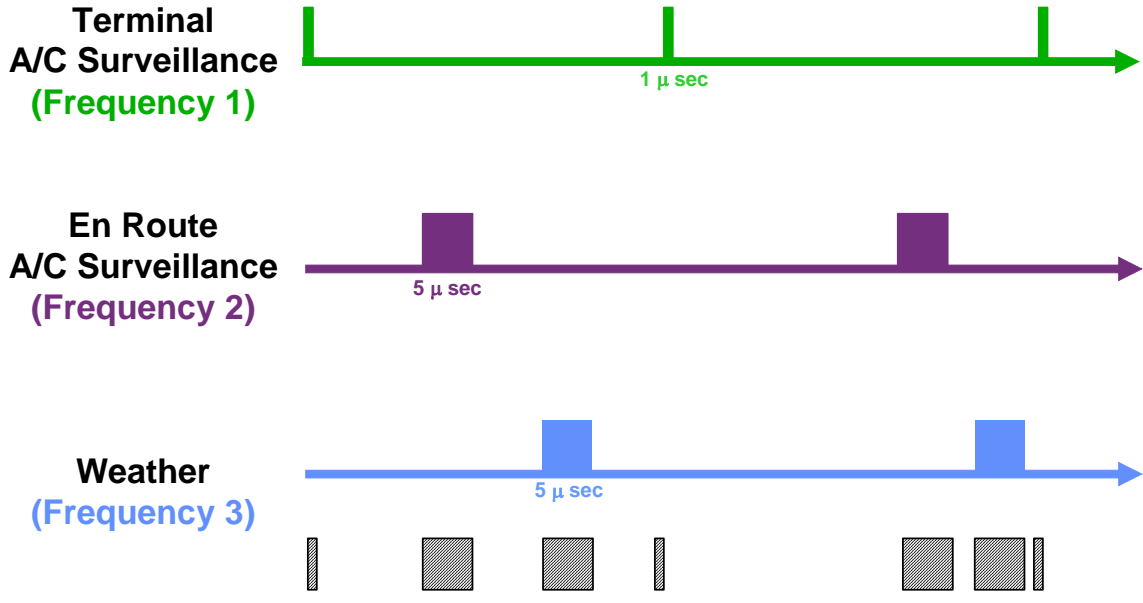

Figure 1. Pulse scheduling for MPAR.

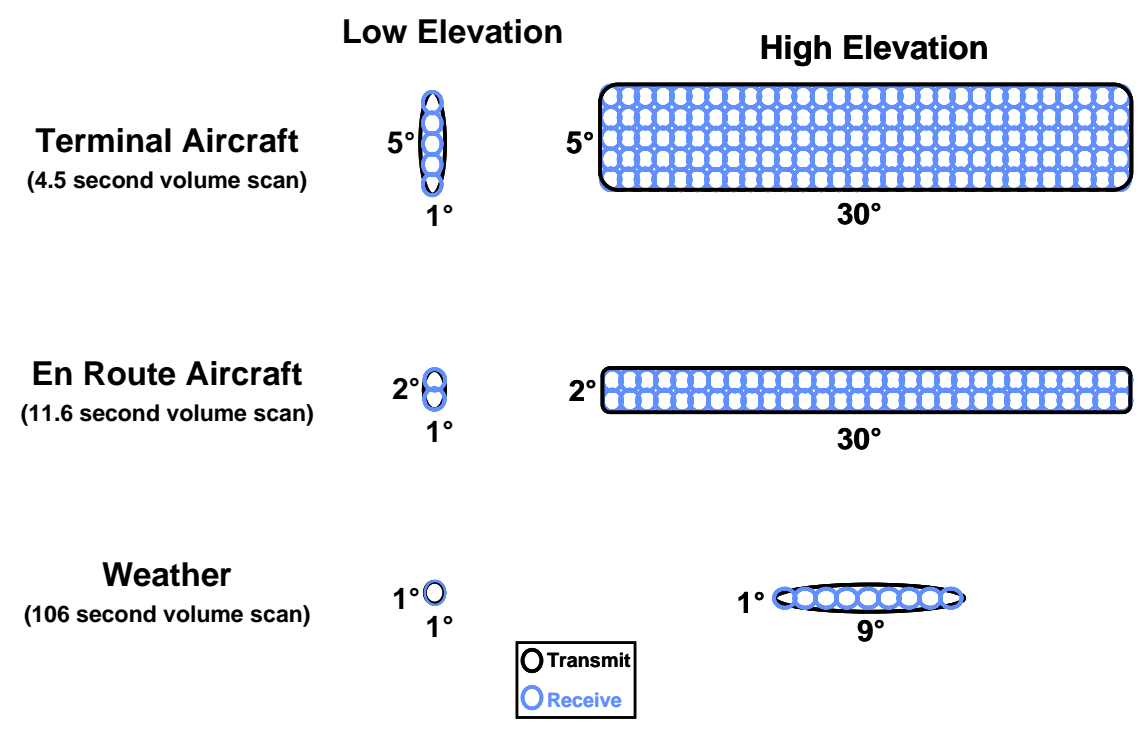

Figure 2. Notional beam patterns for multifunction radar surveillance modes.

Elevation Angle	Number of Dwells	CPI	PRI (s)	Time (s)	Number of Concurrent Azimuth Beams
0	90	18	0.001	1.62	1
5	90	18	0.001	1.61	1
10	89	18	0.001	0.80	2
15	87	18	0.001	0.12	13
20	85	18	0.001	0.05	30
25	82	18	0.001	0.05	30
30	78	18	0.001	0.05	30
35	74	18	0.001	0.04	30
40	69	18	0.001	0.04	30
45	64	18	0.001	0.04	30
50	58	18	0.001	0.03	30
				<b>Total=4.46</b>	

Table 2. MPAR scan timeline for terminal area aircraft surveillance.

To clarify the scanning concept, Table 2 presents an explicit timeline for the terminal aircraft surveillance function. We assume transmission using a 1° (azimuth) by 5° (elevation) beam, and reception using “stacked” 1° x 1° pencil beams. The first column (“Angle”) is the lower edge of the 5° transmit beam and “Number of Dwells” is the associated number of 1° azimuth dwells required. For each dwell, the ASR-9 transmitted waveform is assumed so that the coherent processing interval (CPI) utilizes 18 samples at an average pulse repetition interval (PRI) of 1 ms.

At higher elevation angles, it is possible to increase the scan rate by further spoiling the transmit beam pattern, since, for a fixed altitude ceiling, the maximum range requirement falls off as the cosecant of the elevation angle. The column “Number of Concurrent Azimuth Beams” shows the number of simultaneous 1° azimuth beams across which the transmit energy can be spread while maintaining sufficient energy on target. This number has been capped at 30 to limit the number of beams that must be processed simultaneously. For this calculation, a maximum aircraft surveillance height of 15,000 m (49 kft) is assumed. The column labeled “Time” gives the scan time per 5° elevation wedge and sums to 4.5 s for the entire volume. Thus, relative to the ASR-9, the MPAR terminal aircraft surveillance function would maintain update rate while providing significant capability benefits associated with 1° elevation angle resolution. Total volume scan times derived from similar analysis for the en route aircraft and weather surveillance functions are shown in Figure 2.

## 2.2 Power-Aperture Comparison

Table 3 compares relevant power-aperture products between the concept MPAR and current surveillance radars. Note that the calculations are for worst-case antenna gain corresponding to a scan angle for the multi-function radar of 45°. At broadside, the values would be 4 dB higher than listed. Overall, the concept multi-function radar provides essentially the same target sensitivity as current operational

weather and en route surveillance radars with reasonable assumptions for element peak-power levels and duty cycle. Its power-aperture would be significantly greater than current ASRs, suggesting that a scaled-down “gap filler” could be used to provide additional low altitude surveillance where needed.

## 2.3 Gap-Filler Radars

The siting analysis described in Section 3 indicates that half of the total number of radars required to replicate current airspace coverage would be devoted to surveillance below 10,000’ altitude at relatively short ranges. For this, it would be inefficient to use the large aperture radar described above. A down-scaled MPAR, or “gap-filler”, could provide aircraft surveillance out to about 30 nmi as well as weather surveillance and wind shear protection services at the airport.

Necessary power on target to detect a 1-m<sup>2</sup> aircraft at 30 nmi dictates an aperture consisting of approximately 2000 TR elements per face, a factor of 10 less than the system described above. If deployed as a filled circular array, however, this number of elements would result in a 2.2° x 2.2° beam, which is insufficient resolution for the surveillance functions under consideration. Monopulse techniques could be used to sharpen aircraft angular resolution, but these are problematic in the presence of multiple closely spaced targets and ground clutter. Furthermore, monopulse is not suitable for detection of distributed weather targets.

An alternate approach to achieving high angular resolution with a smaller number of array elements is to employ a dual-density array: a dense inner array at about half-wavelength spacing embedded within a much larger (in physical dimensions) sparse array at several wavelength spacing. The dense inner array is used on transmit to form a moderate-width beam with very low sidelobes. The sparse array is used to form much narrower receive beams. There are grating lobes on receive, but these are in the low-sidelobe region of the transmit beam. The resulting two-way

Function	Radar	Point Target $P_T G_T G_R \lambda^2$ (dB)	Weather Target $\frac{P_T G_T G_R \Delta \theta \Delta \phi}{\lambda^2}$ (dB)
Terminal Aircraft Surveillance	ASR-9	108	
	MF RADAR	120	
En Route Aircraft Surveillance	ARSR - 4	132	
	MF RADAR	129	
Weather	NEXRAD		171
	TDWR		173
	MF RADAR		170

Table 3. Comparison of relevant power-aperture products.

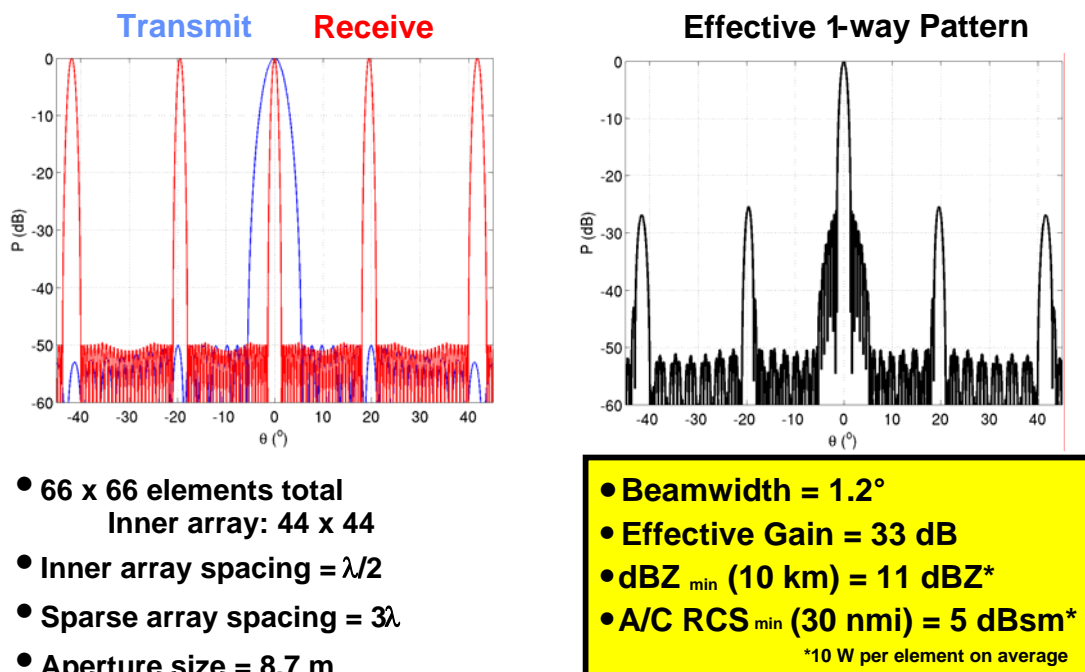

Figure 3: Example beam patterns and sensitivity for a dual-density active array.

beam pattern is dramatically narrower than the corresponding two-way pattern for the inner array alone, with only a modest increase in the number of elements.

Figure 3 shows a specific example where approximately 2000 elements are used in the inner array and an additional 2400 receive-only elements comprise the thinned outer array. The total aperture is 8.7 m in diameter. The resulting antenna pattern

has a 1.2° main lobe and very acceptable -25-dB effective one-way sidelobes. The limitation to this approach is, of course, that relative to a filled aperture configuration, transmitted power is substantially lower as is effective two-way antenna gain. Sensitivity with 10-W peak power for the transmit elements (on average) and a 5- $\mu$ s pulse is equivalent to 11 dBZ for weather targets at a range of 10 km. Although possibly adequate for precipitation mapping and many

Doppler measurement applications, this gap-filler configuration would be substantially less sensitive at short range than are current TDWR or NEXRAD systems.

### 3. MPAR NETWORK AIRSPACE COVERAGE

A second aspect of our study was to determine how many multi-function radars would be required to replicate airspace coverage provided by the current operational radar networks. To accomplish this, we developed a three-dimensional (3D) CONUS data base that defines current coverage capabilities for each of the surveillance functions we are considering: en route aircraft, terminal aircraft, national-scale weather, and terminal weather. For each grid point we determined whether an appropriate radar provides coverage and, if so, what available sensitivity and spatial resolution are provided. High-resolution digital terrain elevation data (DTED) were used to account for terrain effects in this analysis.

We used current NEXRAD locations as the initial site choice for the full-aperture MPAR described in Section 2. For radars located within approximately 50 km of large airports currently equipped with TDWR and/or ASR-9, we adjusted the MPAR site to be close

enough to the airport to meet current siting criteria for the terminal radars. A total of 145 full-aperture MPARs so sited would provide near-seamless airspace coverage above 10,000 ft AGL, replicating the national scale coverage currently provided by the NEXRAD and ARSR networks. In addition, the terminal area weather and aircraft surveillance functions provided by TDWR and ASR would be duplicated at many airports. An additional 144 gap-filler MPARs as described in Section 2 could provide terminal-area weather and aircraft surveillance at remaining U.S. airports.

Figure 4 compares airspace coverage at 1000 ft AGL between current operational radar networks and the concept MPAR network. Differences are minimal and within the coverage areas, MPAR would meet or exceed current radar measurement capabilities—horizontal and vertical resolution, minimum detectable target cross section, and update rate—with one exception. As noted, the gap-filler MPAR would not have the sensitivity for very low cross-section wind-shear phenomena that is currently provided by the TDWR.

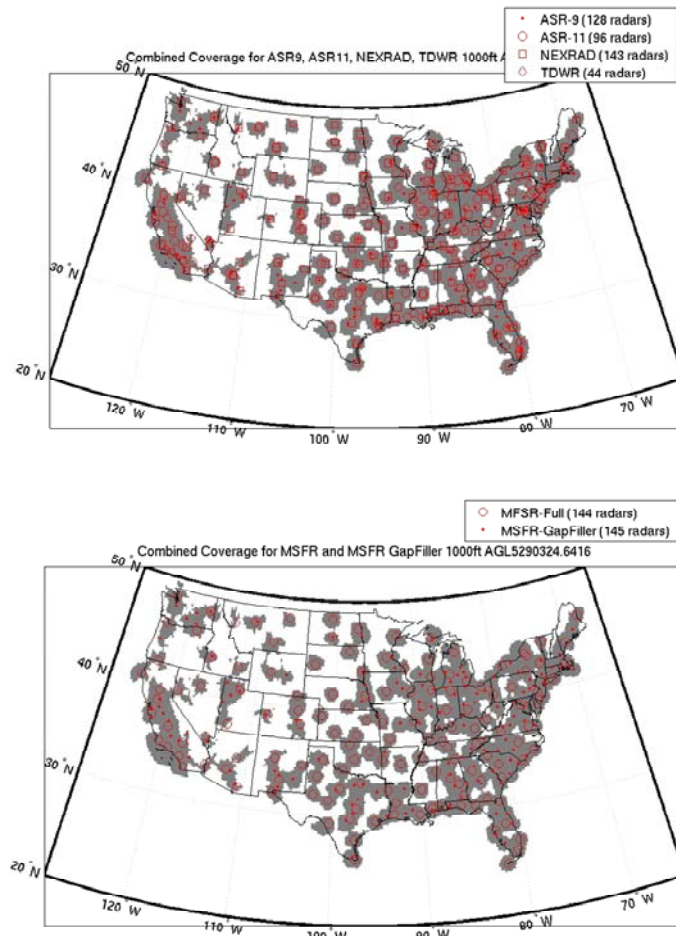

Figure 4. Airspace coverage at 1000 ft AGL provided by current U.S. surveillance radar networks (top) and conceptual MPAR network (bottom).

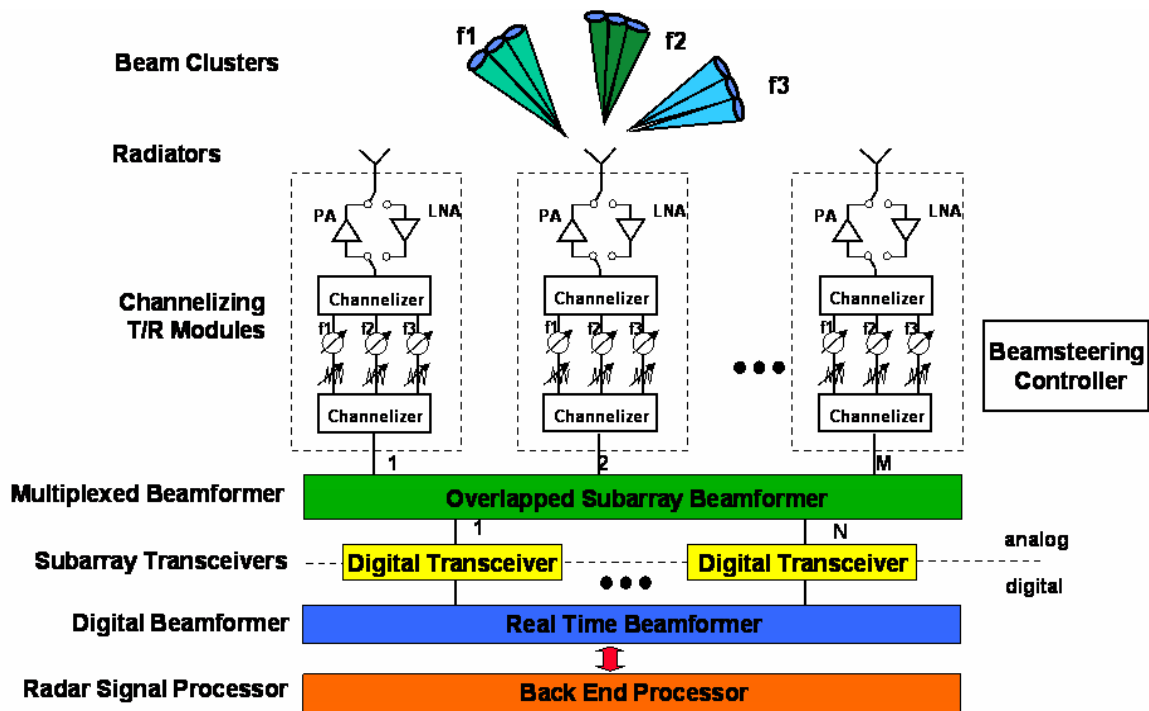

Figure 5. High-level MPAR architecture.

This analysis does not attempt to fully capture the considerations that go into actual site choices for operational radars. It is however, sufficient to support the contention that a significant reduction in the total number of radars needed to provide necessary weather and aircraft surveillance capabilities is possible. Services currently provided by over 500 radars could be duplicated using less than 300 MPARs. In addition, replacement of today's multiple, dissimilar radar types with a single architecture should considerably reduce logistics and maintenance costs.

#### 4. TECHNOLOGY CONSIDERATIONS

Figure 5 depicts the major sub-systems of the requisite multi-function radar. The active array of TR elements is partitioned into "sub-arrays," which are controlled by analog circuitry. A digital input/output port for each sub-array allows the full array aperture to be employed in generating appropriate transmit patterns and clusters of narrow receiving beams. Each receive beam is post-processed through appropriate Doppler filters, parameter estimation algorithms, and target tracking algorithms.

##### 4.1 Transmit-Receive Elements

A major cost driver in an active phased array system is the large number of TR modules. Each element of an active array has a TR module with a phase shifter, a low-noise receive amplifier (LNA), and a high-power transmit amplifier (HPA). In addition, the modules have DC power circuits and beam-steering control functions. In a multifunction

radar system, there are additional components in every TR module to support the multiple modes. For example, a multiple beam system will require separate phase shifters for each independent pointing direction. This will further impact the cost, size, power consumption, thermal management, and control of the modules.

A key benefit at S band (2600-3950 MHz) is the availability of inexpensive RF components (phase shifters, LNAs, HPAs) due to the wireless market. The rapid proliferation of digital cellular telephones, digital communication systems, personal communication systems, wireless data, WiFi, and WiMAX systems has served to reduce critical component costs by an order of magnitude. As a result, the acquisition cost of a phased array is becoming a viable alternative to mechanically steered reflector antennas.

##### 4.2 Overlapped Sub-Array Beamformer

Maximum flexibility for active-array antenna beam-forming is provided if each element is digitized. However, element-level digitization for a large array is unnecessary for most applications. A more effective approach is to partition the aperture into overlapping sub-arrays, whose elements are controlled via analog circuitry, combined and digitized to allow simultaneous beams to be formed digitally at the sub-array combination level. The spacing of the sub-arrays is significantly greater than one-half wavelength, resulting in grating lobes. Analog manifolds control the sub-array elements to produce a flat-topped pattern whose width is less than the spacing of the grating lobes. Thus the composite

pattern provides concurrent, digitally formed clusters of narrow beams as illustrated in Figure 6.

### 4.3 Digital Beamforming (DBF)

Whether digitization takes place at the element level, the sub-array level, or after some amount of analog beamforming, the resulting digital output presents a sizeable processing task for beamforming. The concepts discussed in Section 2 dictate approximately 400 digital sub-arrays (50 TR-elements each) that are processed to form up to 220 simultaneous digital receive beams. Figure 7 shows a possible DBF design, in which all beams are computed concurrently. For each sub-array output, an analog-to-digital converter (ADC) samples the signal into a sequence of digital samples. A three-channel digital receiver recovers F1, F2, and F3 into three separate digital complex signal streams. Using the weights provided by the control host computer, the processor

computes the requisite beams for each surveillance function.

For reasonable assumptions as to the bandwidth and spacing of the three frequency channels, we estimate the computational throughput of this DBF approach to be about 1 tera ( $10^{12}$ ) operations per second. This is a significant challenge to an implementation that uses general-purpose programmable processors (e.g., microprocessors and digital signal processors (DSPs)), but would be tractable using field programmable gate arrays (FPGAs) and/or application-specific integrated circuits (ASICs). The 1200-channel interface between the digital receivers and beamforming units will be complex. The use of a bit-serial communication format will significantly reduce the connectivity at this interface. Lastly, the 220-beam output requires a communication bandwidth exceeding 1 gigabytes per second (GBPS). A wide communication channel will be essential to keep the clock frequency within a practical range.

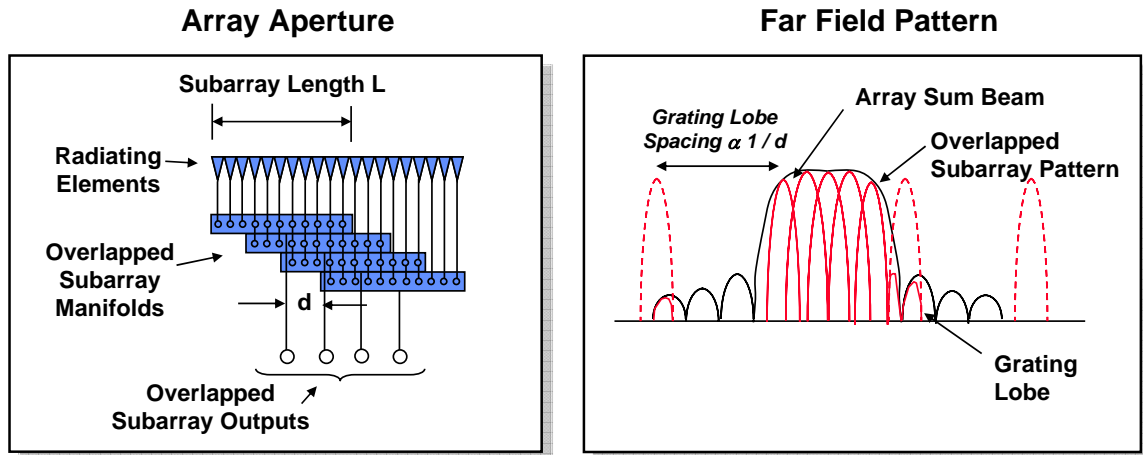

Figure 6. Overlapped sub-array concept.

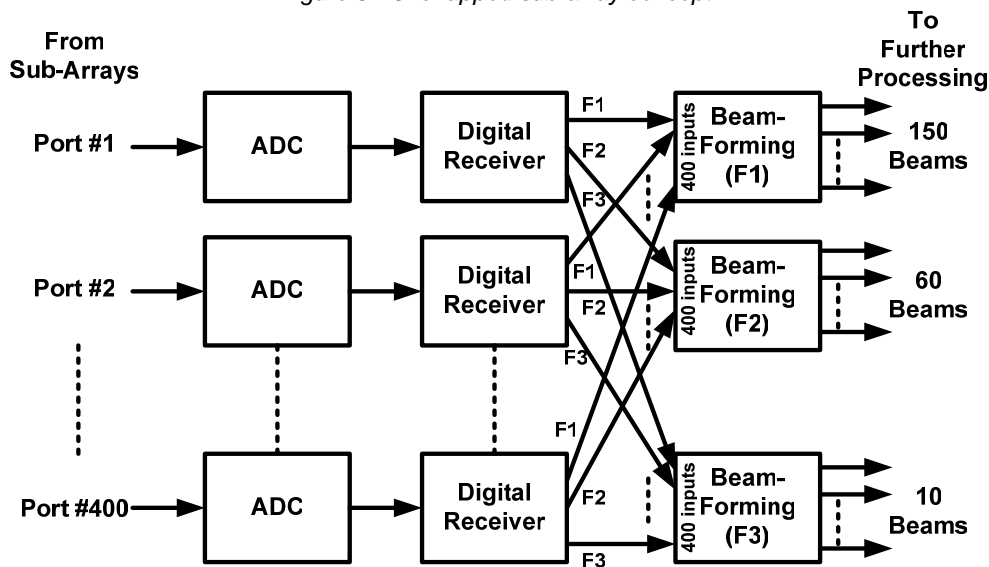

Figure 7: Block diagram of a fully parallel DBF design.



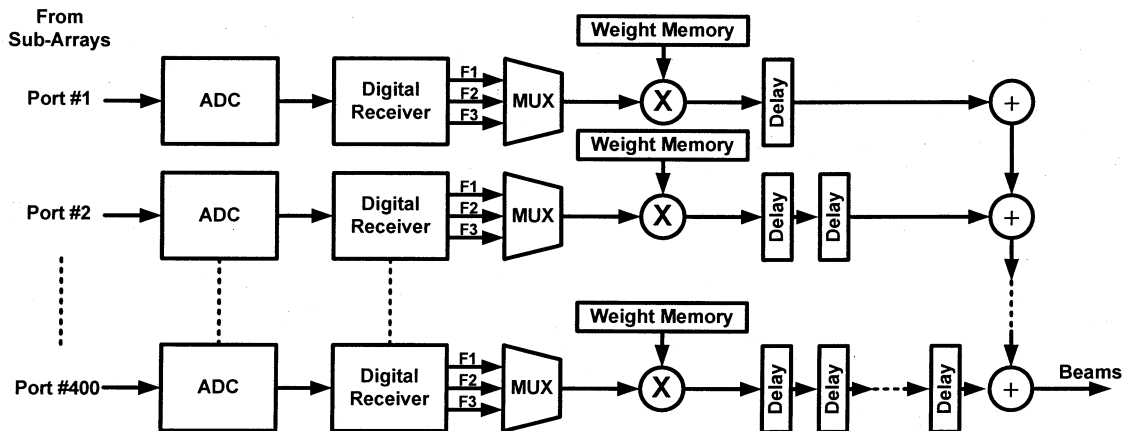

Figure 8: Block diagram of a systolic DBF design.

The high computational throughput can be mitigated by reducing the parallelism of operations. Instead of computing each beam in an individual beamforming unit, a group of beams can be sequentially computed in the same unit. Figure 8 illustrates a systolic design that embodies this concept to the extreme, in which all the beams are computed sequentially. In addition to a much simplified interconnection requirement, the beam output bandwidth is also significantly reduced, since only one beam is produced at a time.

In this approach, the three signals (F1, F2, and F3) coming out of each digital receiver are sequentially multiplied with corresponding weights to form partial beams. Each partial beam is delayed with an amount according to its position in the summing chain. A 400 sub-array implementation will require a maximum of 400-cycle delay. The multiplication, delay, and addition can be readily implemented with FPGA technology.

#### 4.4 Aircraft Post Processing

MPAR would support more selective antenna patterns and flexible scan strategies than current operational radars, thus potentially improving the quality of aircraft surveillance. However, the radar front end will incur a significant transformation in the flow and content of the data provided to the post-processing algorithms as depicted in Figure 9. New post-processing techniques will need to be developed to meet or exceed the performance of the legacy Moving Target Detection (MTD) (Karp and Anderson, 1981) air traffic control search radars. Examples are:

- (i) The use of multiple beam clusters significantly expands the amount of data to be processed. An efficient and affordable open architecture must be defined that reduces acquisition cost by making appropriate use of commercial off-the-shelf solutions. This architecture must also enable technology refresh and the future insertion of new technology and algorithms.
- (ii) Target detections will occur in multiple beams within each beam cluster requiring a new algorithm for correlation and interpolation to the single centroided target report needed for input to existing Air Traffic Control display systems. Also, since the merging of primary and beacon radar target reports cannot depend upon the azimuth and range registration advantages of collocated antennas, modified reinforcement algorithms will also need to be developed.
- (iii) A selective elevation pattern will allow the altitude of detected targets to be estimated, motivating the development of a new highly simplified clutter elimination algorithm.
- (iv) Automatic Dependent Surveillance Broadcast (ADS-B) will replace beacon radars in some regions. Efficient scan strategies should be developed to allow phased arrays radars to confirm and augment ADS-B reports.

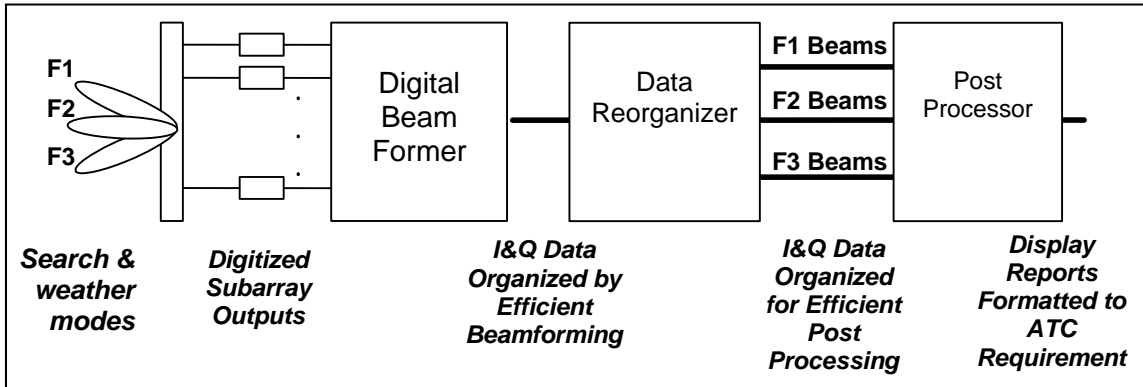

Figure 9: Aircraft detection post-processing block diagram for MPAR.

#### 4.5 Weather Post Processing

As with the aircraft surveillance functions, the weather scan strategies and data processing algorithms should be optimized to exploit the capabilities of a phased-array radar. Significant optimization of scan time can be realized by:

- (i) Removing the requirement for 360° coverage from a single aperture.
- (ii) Exploiting the ability to form concurrent receiving beams along radials where either signal-to-noise ratio is uniformly high or maximum range coverage is limited.
- (iii) Utilization of “decorrelated pulse-pairs” for radials where long CPIs are not required for clutter suppression or spectral-domain weather echo processing.

Such techniques can significantly increase the volume scan update rate and/or improve data quality by allowing for longer dwell time along “high value radials” (e.g., low-elevation tilts for boundary layer wind mapping).

Spaced aperture techniques can be applied by separately processing received signals from halves or quadrants of the full aperture. Such techniques can potentially be used to estimate the cross-range wind component and 3D turbulence fields. Meteorological surveillance requirements for high power-aperture, angular resolution, and long dwell times are likely to have a significant influence on system architecture and cost. It is essential that significant effort go into the evaluation and demonstration of efficient phased-array radar designs and processing approaches for this application.

#### 5. SUMMARY AND DISCUSSION

We have described a concept for a next-generation multifunction phased array radar (MPAR) network that could provide high-quality weather and primary aircraft surveillance capabilities. The authors are optimistic that continuing advances in the critical

technology areas described in Section 4 will make MPAR a technically and economically effective replacement strategy for current radar networks.

A key operational consideration is the future role of primary radar aircraft surveillance in U.S. airspace. The Air Traffic Control system is increasingly moving towards cooperative surveillance technologies (secondary or “beacon” radars and/or GPS-based dependent surveillance). It is likely, however, that there will always be a need for backup primary surveillance to handle the possibility of non-compliant intruders in controlled airspace. DoD and DHS currently rely on FAA primary radars as a major input to their airspace monitoring activities; it seems highly likely that an equivalent capability will be needed for the foreseeable future.

In any scenario, an operational weather radar network remains a critical observing system for the nation. We noted that the power-aperture and angular resolution requirements for weather surveillance significantly exceed corresponding requirements for aircraft surveillance. Thus MPAR will allow the future weather radar network to additionally provide high quality aircraft surveillance services at modest cost. This fact should be considered in discussions about future national surveillance architectures.

#### 6. REFERENCES

- Evans, J., and D. Turnbull, 1989: Development of an automated windshear detection system using Doppler weather radar. *Proc. IEEE*, **77**, 1661-1673.
- Herd, J. S., S. M. Duffy, and H. Steyskal, 2005: Design considerations and results for an overlapped subarray radar antenna. Preprints, *IEEE Aerospace Conf.*, Big Sky, MT.
- Karp, D., and J. R. Anderson, 1981: Moving target detector (Mod II) summary report. Project Rep. ATC-95, DTIC ADA-114709, MIT Lincoln Laboratory, Lexington, MA, 162 pp.
- Lay, R. J., J. W. Taylor, Jr., and G. Brunins, 1990: ARSR-4: Unique solutions to long-recognized

- radar problems. Preprints, *1990 IEEE Int. Radar Conf.*, Arlington, VA, 6-11.
- Serafin, R. J., and J. W. Wilson, 2000: Operational weather radar in the United States: Progress and opportunity. *Bull. Am. Meteor. Soc.*, **81**, 501-518.
- Taylor, J. W. Jr., and G. Brunins, 1985: Design of a new airport surveillance radar (ASR-9). *Proc. IEEE*, **73**, 284-289.
- Weber, M. E., 2005: Wind shear detection processor for terminal air traffic control radars. *J. Atmos. Oceanic Technol.*, submitted.



# APPENDIX C

## **Preliminary Cost Analysis for Multifunction Phased Array Radar**

Current U.S. weather and aircraft surveillance radar networks vary in age from 10 to more than 40 years. Ongoing sustainment and upgrade programs can keep these networks operating in the near to mid term, but the responsible agencies (FAA, NWS, DOD, and DHS) recognize that large-scale replacement activities must begin during the next decade. In 2005, the FAA asked Lincoln Laboratory to participate in a multi-agency evaluation of technology issues and cost trades associated with a replacement strategy involving multifunction phased array radars (MPARs).

Cost considerations are a key element of this study. The current operational ground radar network is composed of seven distinct radar systems with separate Government program offices, engineering support organizations, and logistics lines. A single national MPAR network could reduce life-cycle costs by consolidating these support functions. The total number of deployed radars could also be reduced since the airspace coverages from today's radar networks overlap substantially.

Today, a total of 510 Government-owned weather and primary aircraft surveillance radars operate in the contiguous United States (CONUS). To quantify the potential reduction in radar numbers, we developed a three-dimensional database that defines the current airspace coverage of these networks. High-resolution digital terrain elevation data were used to account for terrain effects. An iterative siting procedure was used to delineate MPAR locations that at least duplicate current coverage. Figure 1 shows that 334 MPARs would provide near-seamless airspace coverage above 5,000 ft AGL, replicating the national-scale weather and aircraft coverage currently provided by the NEXRAD and ARSR networks. The figure indicates that these MPARs would, in addition, provide low-altitude, airport-area weather and aircraft surveillance functions that are today provided by TDWR and ASR-9 or ASR-11 terminal radars. Approximately half of the MPARs are smaller terminal-area units providing range-limited (50 nmi.) coverage underneath the radar horizon of the national-scale network. These terminal area MPARs would be smaller-aperture, lower-cost radars employing the same scalable technology as the full-sized MPAR units.

If the reduced numbers of MPARs and their single architecture are to produce significant future cost savings, the acquisition costs for the network of active electronically scanned array (AESA) radars must be at least comparable to the mechanically scanned radars they replace. To define the technical parameters of the required MPAR and estimate its costs, we developed a conceptual radar configuration, described in detail in Weber et al. (2005). Table 1 summarizes the configuration.

**Legacy Air Surveillance Coverage**

**510 Total Radars, 7 unique types**

**Multifunction Radar Coverage**

**334 Total Radars, 1 type\***

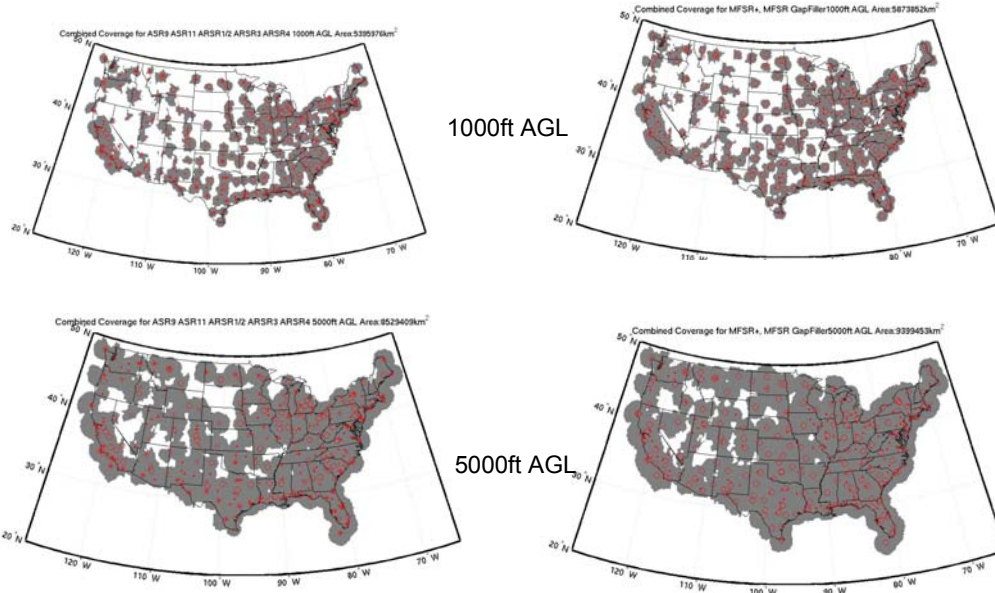
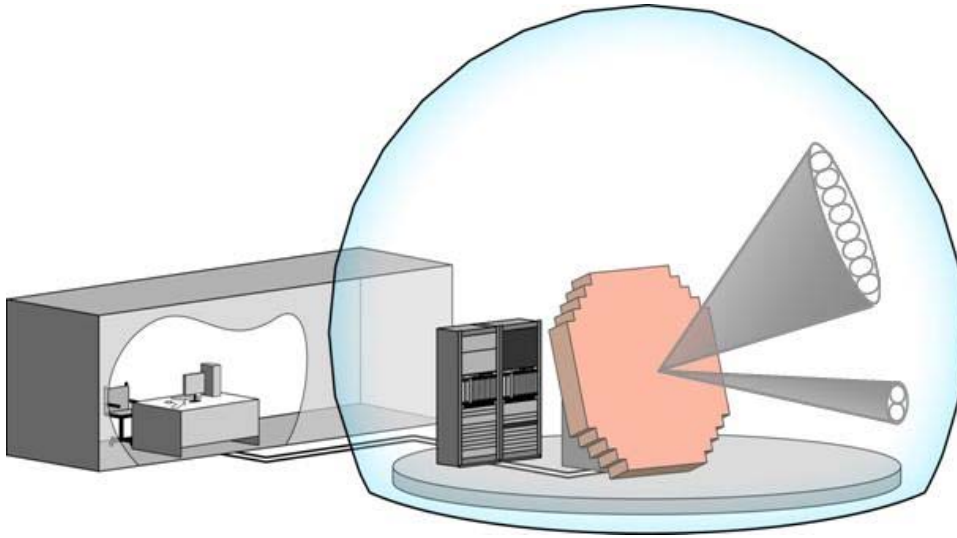

**Figure 1. Airspace coverage comparison between current U.S. operational radar networks (ASR-9, ASR-11, ARSR-1/2, ARSR-3, ARSR-4, NEXRAD, TDWR) and a conceptual MPAR network.**

**Table 1. Concept MPAR Parameters**

Transmit/Receive Elements	Wavelength (frequency) T/R element peak power Bandwidth (per channel) Frequency Channels Pulse Length	10 cm (2.7-2.9 GHz) 1 Watt 1 MHz 3 1-50 μsec
Active Array (4-faced, planar)	Diameter T/R elements per face Beam width - broadside - @ 45° Gain	8 m 20,000 0.7° 1.0° 46 dB
Architecture	Overlapped sub-array - No. of sub-arrays - max. no. concurrent beams	300-400 ~160

Based on this concept development work, a team led by Jeff Herd in Lincoln Laboratory’s RF Array Systems group has commenced detailed design of a scaled “pre-prototype” MPAR array that incorporates the required technologies (Figure 2). This design work is providing technical and cost details that can be used to evaluate the viability of the MPAR concept.



**Figure 2. MPAR pre-prototype array.**

The pre-prototype array will be 4.2 m in diameter, providing sufficient radiated power, antenna gain, and angular resolution ( $2.0^\circ$  pencil beam) to demonstrate key weather and aircraft surveillance functions. The array will radiate and receive in two 1 MHz sub-bands and will utilize a one-dimensional, 16-channel sub-array beamformer to digitally form a vertical cluster of 8 receive beams for each sub-band. A brick module design is utilized with the major RF subsystems in a 6U Eurocard chassis behind the radiating elements. The dual-channel transmit-receive (T/R) element design incorporates low-cost commercial-off-the-shelf (COTS) components and a Lincoln-designed phase shifter to maintain the total parts cost at less than \$20 per T/R element. Key to maintaining low T/R element cost is the use of a modest peak power (1 to 10 W) COTS high-power amplifier. The sub-array beamformer will initially be implemented using a multilayer printed circuit board design based on the Laboratory's X-band Space and Airborne Radar Transformational Array (SPARTA) program (Herd et al. 2005). It is anticipated that the current Laboratory efforts to develop an ASIC-based sub-array beamformer will significantly reduce the costs of this MPAR subsystem relative to the circuit board design. The sub-array output receiver design is derived from the Lincoln Digital Array Radar program (Rabideau et al. 2003) and provides high performance at a modest cost. A scalable, high performance digital beamformer preliminary design was developed by Michael Vai in the Embedded Digital Systems Group. Workable COTS implementation technologies include field programmable gate array (FPGA), ASIC, multichip module (MCM), and mixed signal designs.

Table 2 summarizes MPAR component cost estimates based on this pre-prototype array design. The tabulated numbers are normalized to a per-T/R element basis. Cost reductions indicated in the right-hand column result from either economies of scale or new technologies expected to mature over the next three years. Component costs are consistent with an MPAR that is cost-competitive with current operational radar systems.

**Table 2. MPAR Component Cost Model, Based on Pre-Prototype Array Design***Equivalent Cost per Element*

<b>Component</b>	<b>Pre-Prototype</b>	<b>Full Scale MPAR</b>
<b>Antenna Element</b>	<b>\$1.25</b>	<b>\$1.25</b>
<b>T/R Module</b>	<b>\$20.00</b>	<b>\$20.00</b>
<b>Power, Timing and Control</b>	<b>\$18.00</b>	<b>\$18.00</b>
<b>Digital Transceiver</b>	<b>\$12.50</b>	<b>\$6.25</b>
<b>Analog Beamformer</b>	<b>\$63.00</b>	<b>\$15.00</b>
<b>Digital Beamformer</b>	<b>\$18.00</b>	<b>\$8.00</b>
<b>Mechanical/Packaging</b>	<b>\$105.00</b>	<b>\$25.00</b>
<b>RF Interconnects</b>	<b>\$163.00</b>	<b>\$40.00</b>

The component costs of the full MPAR system summarized in Table 1 would be approximately \$10.7 million. The smaller-aperture system suitable for low-altitude terminal area surveillance would have component costs of approximately \$2.8 million. The pre-prototype subsystem designs support automated fabrication and integration so that, in quantity, the average per-unit cost of the terminal MPAR and full-aperture MPAR networks may be expected to be cost-competitive with the \$5 million to \$10 million procurement costs for today's operational air traffic control and weather radars.

Figures 3 and 4 provide very preliminary estimates of national radar network costs for three scenarios. In scenario one, current radar networks are maintained until their plausible end of life (2012–2025), which depends on the age of the individual network, and then replaced with the same number of single-function radars. In scenario two, an aggressive MPAR development effort allows for replacement of the current radar networks with a reduced number of MPARs in the period 2011–2016. In the third scenario, the current networks are maintained until their end of life and then replaced by MPAR units. Per-unit replacement cost estimates for the legacy radars are based on actual costs in previous procurements. For MPAR, we have set the full aperture unit cost at \$15 million and the smaller terminal area MPAR unit cost at \$5 million. Recall that approximately equal numbers of these two sizes of MPAR units are needed to efficiently duplicate today's airspace coverage.

Based on the Laboratory's long-term involvement with the TDWR, NEXRAD, and ASR-9 life-cycle support and enhancement programs, we have estimated the yearly, per-unit operations and maintenance (O&M) costs of the legacy radars as \$ 0.5 million per year. This figure considers the numbers of personnel in the associated Government program



offices, engineering support facilities, and operational facilities, as well as the agency’s yearly budget allocations for these systems. By consolidating today’s seven separate operational radar networks into one, per-unit expenditures for nonrecurring engineering and hardware developments (e.g., processor refreshes, transmitter upgrades) could be substantially reduced because these tasks would no longer be performed independently on multiple systems.

We estimate that approximately half of the Government’s O&M costs for the legacy radar networks fall into this nonrecurring category. Based on this argument, we have estimated that the 7-to-1 system support consolidation associated with an MPAR network could reduce per-unit O&M costs to approximately \$0.3 million per year. We view this as conservative since MPAR may also reduce recurring O&M costs by eliminating single point-of-failure scenarios associated with the legacy radars’ transmitters and mechanical drive subsystems.

As seen from Figure 3, for the 20-year period considered the aggressive MPAR implementation scenario reduces total costs by approximately \$3.0 billion relative to a “sustain and replace” strategy. The majority of this saving accrues from reduced O&M costs associated with the smaller number of radars required and our assumption that a consolidated national radar network can substantially reduce nonrecurring engineering costs. A downside to this scenario is that cumulative costs are actually higher in the first half of the time period because MPAR acquisition expenditures are not fully offset until legacy radar system replacements become mandatory.

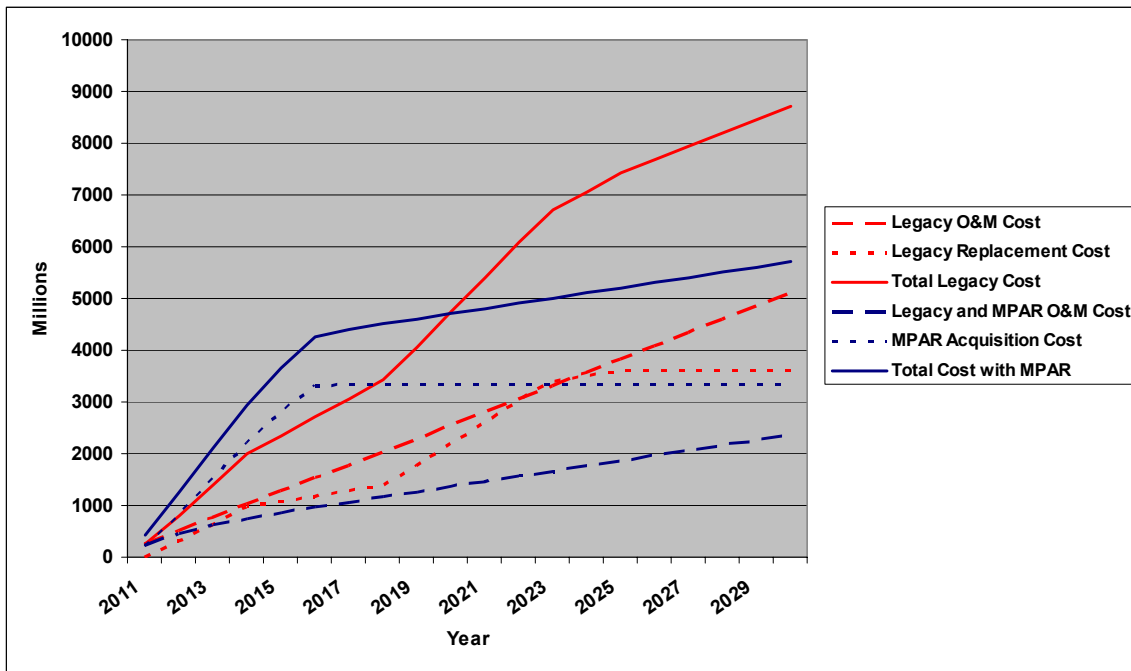

**Figure 3. Comparison of cumulative costs for a “sustain and replace legacy radars” strategy (red) versus aggressive implementation of MPAR (blue).**

In the third scenario, illustrated in Figure 4, MPAR units are fielded on an as-needed basis. This fielding approach minimizes the early-period cost disadvantage of the second scenario but reduces (to \$2.4 billion) the net savings over the total 20-year time period.

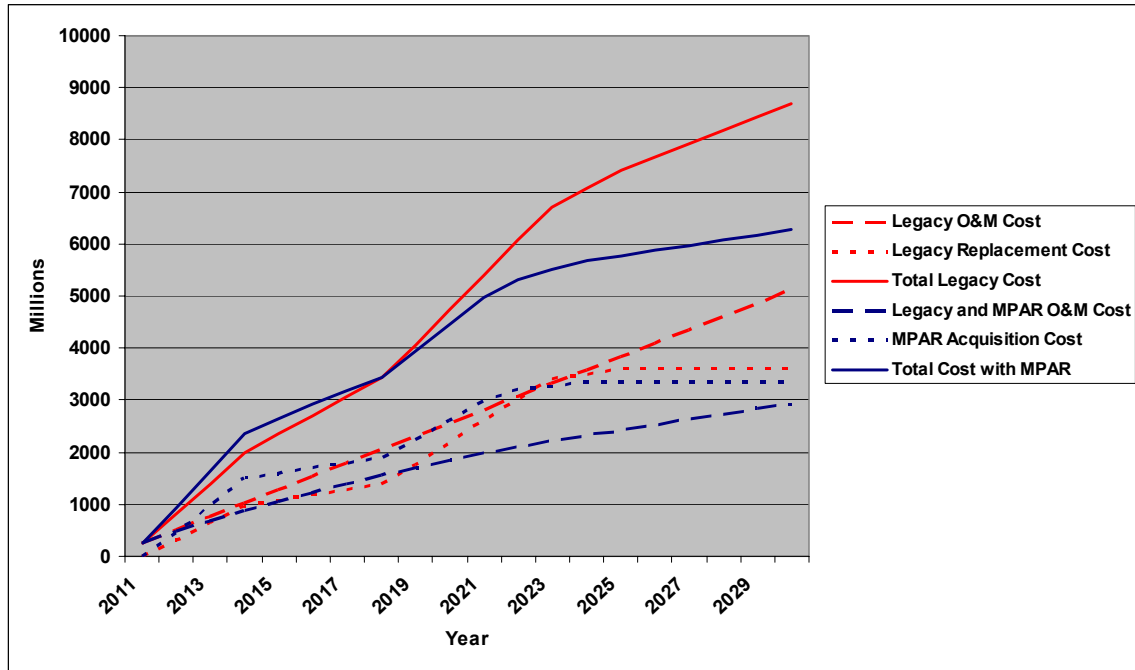

**Figure 4. Comparison of cumulative costs for a “sustain and replace legacy radars” strategy (red) versus “replace with MPAR when needed” strategy (blue).**

Clearly, these preliminary radar acquisition and O&M cost models must be refined and validated. In the authors’ opinion, however, the favorable overall cost picture for MPAR based on current-technology prices, coupled with expectations that essential components derived from the mass-market wireless and digital processing industries will continue to decrease in price, indicates that active-array, multifunction radar technology is a promising option for next-generation U.S. weather and aircraft surveillance needs. In addition, the improved and expanded hazardous weather detection, weather forecasting and aircraft surveillance capabilities of an MPAR network could potentially benefit security, safety, and air traffic control efficiency beyond that provided by the systems replaced.

# APPENDIX D

## **MPAR R&D Plan Detailed Task Time Line and Cost**

The following time line breaks down R&D tasking and cost by year for the three major components of the proposed R&D plan:

- Technology development and test
- Proof of MPAR operational concepts
- Refinement of the MPAR network concept.

### **MPAR Technology Development and Test**

*2007 Architecture and Subsystem Development for an MPAR Prototype (\$3 million)*

1. Detailed MPAR Architecture study. Develop MPAR Preliminary Design Review package based on completed concept definition study.
2. Develop design concept for key MPAR subsystems. Assess critical performance and cost issues. Lay out plan for subsystem prototype development and test.
  - Ultra low-cost, multichannel T/R module
  - Ultra low-cost overlapped sub-array beamformer
  - Multichannel transceiver (sub-array A/D converter)
  - Digital beamforming architecture and processing algorithms
  - Weather and aircraft post-processors
3. Industry contract for “low-risk” multichannel T/R-module development
4. Industry contract for “low-risk” overlapped sub-array beamformer

*2008 Subsystem Development and “Pre-prototype” Contract (\$ 7 million)*

1. Resolve subsystem critical performance and cost issues. Develop CDR packages. Develop and test subsystem prototype units.
2. Compare “ultra low-cost” and “low-risk” T/R modules and sub-array beamformer. Down-select based on performance/cost trades.
3. Develop MPAR “Pre-Prototype” Critical Design Review package
  - Approximately 225 T/R modules
  - 2 or 3 frequency channels
  - Approximately 6 sub-arrays

- Approximately 5 concurrent beams

*2009 MPAR Pre-Prototype Integration (\$8 million)*

1. Integrate MPAR subsystems into functioning small aperture radar
2. Continue subsystem refinement and cost-reduction assessments
3. Develop final pre-prototype test and demonstration plan
4. Commence pre-prototype test and demonstration program

*2010 Full-Sized MPAR Prototype Contract Award (\$10 million)*

1. Complete MPAR pre-prototype tests. Finalize sub-system designs.
2. Develop Critical Design Review Package for full-sized MPAR Prototype
  - Approximately 20,000 T/R elements per face x 4 faces, or equivalent cylindrical array
  - 2 or 3 frequency channels
  - Approximately 200 overlapped sub-arrays
  - Approximately 100 concurrent beams
3. Contract award for MPAR prototype development

*2011 MPAR Prototype Development and Test Plan (\$29 million)*

1. Develop MPAR prototype
2. Develop Test Plan
  - Subsystem tests
  - “In-plant” tests
  - Live-target tests
  - Operational tests

*2012 MPAR Prototype Tests (\$33 million)*

1. Conduct subsystem and in-plant tests
2. Deploy prototype to Government-designated site for live target tests
3. Develop interfaces to Government-designated operational facilities supporting targeted multiple mission (e.g. NWS WFO, FAA Terminal Approach Radar Control (TRACON) Centers and Air Route Traffic Control Centers (ARTCCs), North American Aerospace Defense Command NORAD)

*2013 Live-Target Tests and Operational Demonstrations (\$29 million)*

1. Maintain and adapt MPAR prototype as necessary
2. Conduct live-target tests

- Demonstrate weather surveillance requirements
  - Demonstrate non-cooperative target surveillance requirements
3. Deploy prototype to Government-designated operational test site. Interface to operational facilities.

*2014 MPAR Operational Test and Demonstration (\$29 million)*

1. Maintain and adapt MPAR prototype as necessary
2. Conduct MPAR prototype operational tests involving NWS, FAA, DOD/DHS and private sector users. Operate prototype 24/7 in operational environment
3. Collect and analyze data on user acceptability

*2015 Technology Transfer (\$10 million)*

1. Continue prototype operational demonstration
2. Prepare technology transfer package
  - Functional requirements
  - Subsystems performance specifications
  - Technology exhibits

**Total for MPAR Technology Development and Test            \$158 million**

**Proof of MPAR Operational Concepts**

*2007 Signal processing and scanning strategies for weather observations (\$6 million)*

1. Upgrade NWRT transmitter with pulse compression and dual frequency capability
2. Start development of adaptive scan to fine tune interrogation of storms
3. Implement oversampling and whitening to speed volume update
4. Finish design of aircraft tracking enhancements
5. Continue display and algorithm development to match the MPAR capabilities (i.e., non-sequential, 3-D data stream)

*2008 Aircraft tracking and weather observations (\$ 6 M)*

1. Add aircraft tracking capabilities to NWRT
2. Evaluate simultaneous collection of weather data and detection of aircraft

*2009 Aircraft tracking and dual polarization sub-array (\$ 11 M)*

1. Use NWRT and/or other existing units to evaluate capability of dual polarization modules

2. Design and build dual-polarized phased sub-array
  3. Modify displays and algorithms to handle dual-polarized phase array data
  4. Test algorithms for acquisition of aircraft
  5. Assimilate MPAR data into numerical models
- 2010 *Aircraft tracking and dual polarization sub-array (\$ 11 M)*
1. Test dual-polarized phased sub-array
  2. Collect data with the dual-polarization sub-array
  3. Test algorithms for tracking of aircraft
  4. Assimilate MPAR data into numerical models
- 2011 *Dual polarization sub-array (\$ 6 M)*
1. Evaluate dual-polarization data from the sub-array
  2. Test display and dual-polarization algorithms with data from the sub-array
  3. Assimilate MPAR data into numerical models
- 2012 *Research and Development towards operational applications (\$ 6 M)*
1. Research using NWRT data
  2. Assimilate MPAR data into numerical models
  3. Evaluate results
- 2013 *Research and Development towards operational applications (\$ 6 M)*
1. Research using NWRT data
  2. Assimilate MPAR data into numerical models
  3. Evaluate results

**Total for Proof of MPAR Operational Concepts : \$ 52 M**

### **Refinement of MPAR Network Concept**

#### **Testing of Short Wavelengths**

- 2007 *Polarimetry at 3- and 5-cm wavelengths (\$ 1 M)*
1. Assemble 3-cm polarimetric radar (parabolic dish)
  2. Study and understand scattering specificities of dual-polarized signals at the 5-cm and 3-cm wavelengths
  3. Examine existing polarimetric data at 5-cm wavelength
  4. Collect data with the 3-cm polarimetric radar

2008	<i>Polarimetry at 3- and 5-cm wavelengths: study and subsystem development (\$1 M)</i>	
	<ol style="list-style-type: none"> <li>1. Analyze the 3-cm polarimetric radar data</li> <li>2. Add polarimetric capability to NOAA's C-band mobile radar</li> <li>3. Explore phased array antenna technology for 3- and 5-cm radars and identify cost-effective solutions</li> <li>4. Detailed gap-filler study</li> <li>5. Develop gap-filler Preliminary Design Review package</li> <li>6. Procure and test various flatplate 3-cm wavelength antennas</li> </ol>	
2009	<i>Subsystem development and proof of concept (\$ 1 M)</i>	
	<ol style="list-style-type: none"> <li>1. Collect data with both the 3- and 5-cm polarimetric radars</li> <li>2. Establish relative merits of the 3- and 5-cm wavelengths using data</li> <li>3. Continue search and evaluation of inexpensive phased array technology for the 3- and 5-cm wavelengths</li> </ol>	
2010	<i>System development and proof of concept (\$ 1 M)</i>	
	<ol style="list-style-type: none"> <li>1. Work on algorithms for rainfall measurement and precipitation classification with short-wavelength radars</li> <li>2. Identify a relatively inexpensive phased array technology for the 3- and 5-cm wavelengths</li> <li>3. Make the choice between the 3- and 5-cm wavelengths</li> </ol>	
2011	<i>Proof of concept development (\$ 1 M)</i>	
	<ol style="list-style-type: none"> <li>1. Procure and test an appropriate dual-polarization phased array antenna</li> <li>2. Devise strategy for correction attenuation and mitigating range and velocity ambiguities</li> <li>3. Incorporate the critical functional requirements into the MPAR phased array</li> </ol>	
	<b>Total for Refinement of MPAR Network Concept</b>	<b>\$5 million</b>
<hr/>		
	<b>Total for Three Components of MPAR Risk Reduction R&amp;D</b>	<b>\$215 million</b>





# APPENDIX E

## Acronyms

ADC	analog-to-digital converter
ADS-B	Automatic Dependent Surveillance Broadcast
AESA	active electronically scanned array
ARSR	air route surveillance radar
ASIC	application-specific integrated circuit
ASR	airport surveillance radar
ATD	atmospheric transport and diffusion
CASA	Collaborative Adaptive Sensing of the Atmosphere
CONUS	contiguous United States
COTS	commercial off the shelf
CPI	coherent processing interval
DARPA	Defense Advanced Research Projects Agency
DBF	digital beamforming
DOD	U.S. Department of Defense
DOE	U.S. Department of Energy
DHS	U.S. Department of Homeland Security
DTED	digital terrain elevation data
EPA	U.S. Environmental Protection Agency
FAA	Federal Aviation Administration
FCMSSR	Federal Committee for Meteorological Services and Supporting Research
FEMA	Federal Emergency Management Administration
FPGA	field programmable gate array
FHWA	Federal Highway Administration
GaN	gallium nitride
GEOSS	Global Earth Observation System of Systems
GBPS	gigabytes per second
GPS	Global Positioning System
HMMWV	High Mobility Multipurpose Wheeled Vehicle
HPA	high-power transmit amplifier
ICMSSR	Interdepartmental Committee for Meteorological Services and Supporting Research
JAG/PARP	Joint Action Group for Phased Array Radar Project
LCMR	Low-cost Counter Mortar Radar
LNA	low-noise receive amplifier
LRU	Line Replaceable Unit
MCM	multichip module
MIT	Massachusetts Institute of Technology
MMIC	monolithic microwave integrated circuit
MMR	Multi-Mission Radar

---

MPAR	multifunction phased array radar
MP-RTIP	Multi-Platform Radar Technology Improvement Program
MRCR	mechanically rotating conventional radar
NAS	National Airspace System
NASA	National Aeronautics and Space Administration
NCAR	National Center for Atmospheric Research
NEXRAD	Next Generation Weather Radar
NGATS	Next Generation Air Transportation System
NOAA	National Oceanic and Atmospheric Administration
NORAD	North American Aerospace Defense Command
NRC	National Research Council
NSSL	National Severe Storms Laboratory
NWP	numeric weather prediction
NWRT	National Weather Radar Testbed
NWS	National Weather Service
O&M	operations and maintenance
OFCM	Office of the Federal Coordinator for Meteorological Services and Supporting Research
PRI	pulse repetition interval
QPF	quantitative precipitation forecasting
R&D	research and development
RF	radio frequency
SME	subject matter expert
SPARTA	Space and Airborne Radar Transformational Array
TDWR	Terminal Doppler Weather Radar
T/R	transmit-receive
TRACON	Terminal Approach Radar Control
VSR	Volume Search Radar
WG/MPAR	[proposed] MPAR Working Group
WSR-88D	Weather Surveillance Radar 1988 Doppler

# APPENDIX F

## JAG/PARP Participants

### *Joint Action Group Members*

Dr. James (Jeff) Kimpel, *Co-Chair*  
Director, NOAA National Severe Storms Lab  
Norman, OK

Col Mark P. Weadon USAF, *Co-Chair*  
NOAA Office of Military Affairs  
Washington, DC

LtCol Robert Rizza USAF, *Executive Secretary*  
OFCM  
Silver Spring, MD

Mr. Robert S. Freeman, *Member*  
Office of Oceanographer of the Navy  
U.S. Naval Observatory, Building 1  
Washington, DC

Mr. John Gambel, *Member*  
Mitigation Division, Emergency Preparedness  
and Response  
U.S. Department of Homeland Security  
Washington, DC

Dr. Ramesh Kakar, *Member*  
Atmospheric Dynamics Program  
National Aeronautics and Space Administration  
Washington, DC

Mr. Ken Leonard, *Member*  
Federal Aviation Administration  
Washington, D.C.

Mr. Eric Luebehusen, *Member*  
U.S. Department of Agriculture  
Washington, DC

Dr. Daniel Melendez, *Member*  
NOAA National Weather Service  
Silver Spring, MD

Dr. Stephan P. Nelson, *Member*  
Office of Atmospheric Sciences  
National Science Foundation  
Arlington, VA

Mr. Rickey C. Petty, *Member*  
Atmospheric Sciences Office of Biological and  
Environmental Research, Office of Science  
U.S. Department of Energy  
Germantown, MD

Mr. Paul A. Pisano, *Member*  
Federal Highway Administration  
Washington, DC

Mr. John Vimont, *Member*  
Park Services  
U.S. Department of Interior

Mr. William E. Benner, *Alternate*  
William J. Hughes Technical Center  
Federal Aviation Administration  
Atlantic City, NJ

Mr. Richard Heuwinkel, *Alternate*  
Federal Aviation Administration  
Washington, DC

### **Subject Matter Experts (SME) and Observers**

Dr. Tim Crum, **SME**  
NOAA Radar Operations Center  
Norman, OK

Dr. Kelvin K. Droegemeier, **SME**  
Director, Center for Analysis and Prediction of  
Storms, University of Oklahoma  
Norman, OK

Mr. Douglas E. Forsyth, **SME**  
Chief, Radar Research and Development  
Division  
NOAA National Severe Storms Lab  
Norman, OK

Dr. David J. McLaughlin, **SME**  
Director, NSF Engineering Research Center for  
CASA, College of Engineering, University of  
Massachusetts, Amherst, MA

Mr. John Heimmer, **SME**  
BCI Inc., Morristown, NJ

Dr. Barry S. Perlman, **SME**  
Communications-Electronics Research,  
Development and Engineering Center  
U.S. Army Research, Development and  
Engineering Command, Ft. Monmouth, NJ

Mr. William Spaulding, **SME**  
SAIC/Air Force Weather Agency  
O'Fallon, IL

Mr. Andy Stern, **SME**  
Mitretek Systems  
Falls Church, VA

Dr. Mark Weber, **SME**  
MIT Lincoln Laboratory  
Lexington, MA

Ms. Magda Batista, **Observer**  
William J. Hughes Technical Center  
Federal Aviation Administration

Dr. Jonathan M. Berkson, **Observer**  
U.S. Coast Guard Headquarters  
Washington, DC

Mr. Jerry Brotzge, **Observer**  
Center for Analysis and Prediction of  
Storms/CASA, University of Oklahoma  
Norman, OK

Dr. V. Chandraseker, **Observer**  
Deputy Director, CASA  
Dept. of Electrical Engineering  
CSU-CHILL Radar Facility  
Fort Collins, CO

Mr. William Curry, **Observer**  
Deputy Technical Director  
Oceanographer of the Navy  
Washington, DC

Dr. Bruce A. Davis, **Observer**  
Director, Interagency Modeling and Atmospheric  
Assessment Center  
U.S. Department of Homeland Security  
Washington, DC

Dr. Ronald J. Ferek, **Observer**  
Office of Naval Research  
Arlington, VA

Mr. James Flavin, **Observer**  
MIT Lincoln Laboratory  
Lexington, MA

Dr. John Gerlach, **Observer**  
NASA Goddard Space Flight Center  
Wallops Island, VA

Dr. Jeffrey Herd, **Observer**  
MIT Lincoln Laboratory  
Lexington, MA

Mr. David E. Johnson, **Observer**  
Office of the Deputy Chief of Staff, G-2  
U.S. Army, Washington, DC

Ms. Nanette Gordner Kalani, **Observer**  
William J. Hughes Technical Center  
Federal Aviation Administration  
Atlantic City, NJ

Mr. Eric J. Knapp, **Observer**  
NSF Engineering Research Center for CASA  
University of Massachusetts, Amherst, MA

Col (Retired) Joel Martin, **Observer**  
University of Oklahoma  
Norman, OK

Mr. David Pace, **Observer**  
Federal Aviation Administration  
Washington, DC

Mr. Avery Sen, **Observer**  
NOAA Social Science Initiative  
Silver Spring, MD

Mr. Garth Torok, **Observer**  
William J. Hughes Technical Center  
Federal Aviation Administration  
Atlantic City, NJ



# APPENDIX G

## **PHASED ARRAY RADAR PROJECT JOINT ACTION GROUP Capabilities Questionnaire**

January 23, 2005

The purpose of the Phased Array Radar Project Joint Action Group (PARP/JAG) Capabilities Questionnaire is to gather information about existing radar systems from all relevant agencies. The information gathered will be used to develop a research and development plan that will determine the feasibility and affordability of acquiring a multi-agency, multi-purpose PAR in the 10 – 25 year timeframe.

In answering the questions be as specific and detailed as possible when naming the systems, requirements, and capabilities of the radars used by your agency or organization. Please complete this questionnaire for your agency or organization by February 28, 2005 and forward it to the JAG/PARP Executive Secretary (robert.rizza@noaa.gov).

### **Present Capability**

1. If your agency or organization currently operates ground-based radar systems, or uses data from such systems, please provide current capabilities / requirements for each system. (Some questions below apply only to agencies that own/operate radar systems)

a. What is (are) the phenomenon (phenomena) you need to sense (e.g., aircraft, hydrometeors, debris, birds, volcanic ash, clear air, etc.)?

b. What spatial and temporal resolution is required to characterize your phenomena? Consider horizontal and vertical resolution, rate of change, refresh rate, separation distance, etc. (Use current observational resolution in the absence of stated requirements.)

c. What sampling volume is required for you to detect a particular phenomenon? What scanning mode(s) do you employ?

d. Are your radars networked? If so, please describe the network. What geographical area do they cover (CONUS?, regional?, local?)

e. Do you employ mobile radars for specific events? If yes, please describe these events.

f. Once the phenomenon is detected, do you employ the radar to interrogate it further (e.g., change scanning strategy, stare or dwell, etc.)? If yes, please explain.

- Do you require general surveillance and interrogation modes to operate simultaneously? If yes, please explain.
- g. Describe the processing your system's raw data undergoes prior to dissemination to users. This might include deriving such things as where the phenomenon came from, where it will be in the future, 2D winds from Doppler winds, etc.
- h. Is your current radar system constrained to some physical size/weight? If yes, please provide the rationale for the constraints.
2. What are your current requirements for system reliability? Please state the rationale for your requirements.
3. Is there a commercial market for data and/or information from your radar system(s)? If yes, please explain.
4. Are there any estimates of the socio-economic value resulting from your radar system(s) (e.g., costs avoided, lives saved, economic activity enabled, etc.)? If yes, please provide them.
5. Is there any additional information you wish to provide?

### **Anticipated Additional Future Needs**

This section follows the format of the Present Capability section immediately above, although emphasis is now focused on additional future needs. Please provide estimates of your agency's or organization's future ground based radar needs in the 2015 – 2030 timeframe. Recall that the goal here is to provide input that can be factored into a research and development plan.

1. Please provide your best estimate of future needs for data and information from ground based radar system(s).
- a. What additional phenomenon (phenomena) might you need to sense? What present phenomena might need improved surveillance?
- b. What spatial and temporal resolution might be required to characterize your identified phenomenon (phenomena)? Consider horizontal and vertical resolution, rate of change, refresh rate, separation distance, etc.
- c. What sampling volume might be required for you to detect this (these) phenomenon (phenomena)? What scanning mode(s) might you employ?
- d. Will your radars be networked? If so, please describe the network. What geographical area will it cover? (CONUS? regional? local?)



- e. Will you need to employ mobile radars for specific events? If yes, please describe these events.
  - f. Once the phenomenon is detected, will you employ the radar to interrogate it further? (e.g., change scanning strategy, stare or dwell) Will you require general surveillance and interrogation modes to operate simultaneously? If yes, please explain.
  - g. Describe any additional processing requirements of your future system's raw data prior to dissemination to users.
  - h. Are there any additional system "size" constraints that could/should be considered that would enhance your future system?
2. What will be your new requirements for system reliability?
  3. Do you foresee new commercial markets for the additional data and information from your future radar system(s)?
  4. Are there any anticipated additional socio-economic value resulting from your future radar system(s)?
  5. Please provide any known or anticipated cost constraints on upgrading or replacing you present system(s).
  6. Is there any additional information you wish to provide?

**Due Date:** 28 Feb 05