

DynCorp
Dynamic. Dedicated. Driven.

**The DynCorp
Team:**

HIPAA & PKI

in the

**Federal
Government**

**Presented to:
Health Care PKI Working Group**

DynCorp
Dynamic. Dedicated. Driven.

Agenda

Presentation Objective

DynCorp Team Corporate Overview

HIPAA Discussion

PKI Discussion

Summary

Open Discussion

DynCorp

Dynamic. Dedicated. Driven.

Vision

Delivering value-added

solutions in Outsourcing

and Information Technology

to all of our customers

Presentation Objective

DynCorp
Dynamic. Dedicated. Driven.

Vision
vision

Delivering value-added

solutions in Outsourcing

and Information Technology

to all of our customers

DynCorp Team Corporate Overview

DynCorp Team Corporate Overview

Information Technology and Systems Integration company founded in 1946, headquartered in Reston, VA, with 550 operational locations worldwide

Over 23,000 professionals and revenues of \$2.3 billion – over 50 consecutive years of growth and profitability

DynCorp Culture

- Customer-Centric Focus
- People Orientation, Employee Fulfillment
- Uncompromising integrity; Employee Empowerment

Technical Leadership

- 18th Largest Systems Integrator
- Full Life Cycle Methodology (SEI-CMM Level 3 and ISO 9001)
- Member of the Software Productivity Consortium
- More than 30 Major Government Customers
 - Civil Agencies (HHS, EPA, DOJ, DOT, DOS,DOE)
 - DoD (Navy, Army, Air Force, and Joint Programs)

DynCorp Team Corporate Overview

Case Study - AdvanceMed Corporation

This DynCorp company currently provides services to Government agencies such as Health and Human Services, CMS (HCFA) that apply HIPAA security and standards initiatives.

- Program Safeguard Contractor
- Statistical Analysis Center
- Comprehensive Error Rate Testing
- Therapy Review Program

DynCorp Team Corporate Overview

Case Study – AdvanceMed (*continued*)

- Provides Internal Security:
 - Internal Corporate PKI
 - Operates Certificate Authority
 - Ensures Integrity of all Systems in AdvanceMed
 - Exchanges “Keys” with other Authorities to receive medical and healthcare information

DynCorp

Dynamic. Dedicated. Driven.

Vision

vision

Delivering value-added

solutions in Outsourcing

and Information Technology

to all of our customers

DynCorp Team Corporate Overview

DynCorp

Dynamic. Dedicated. Driven.

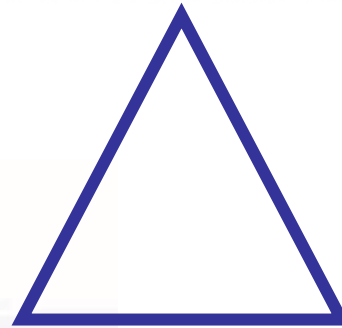

DynCorp
Dynamic. Dedicated. Driven.

Vision
vision

Delivering value-added

solutions in Outsourcing

and Information Technology

to all of our customers

HIPAA

HIPAA

Healthlink

Proven Performance. Guaranteed Results.

Largest privately-held consulting services company for the healthcare IT industry

- 2000 Revenue= \$27.6 million
- 2001 Revenues = \$32 million
- 220 FTEs

Unmatched expertise in:

- Enterprise business and clinical processes
- Technology integration and implementation
- Customized healthcare applications
- HIPAA compliance management

HIPAA

Healthlink and HIPAA

Assisting over 350 provider organizations with compliance

Exclusive Partnerships

- Premier contract to provide partners a best practice approach
- Eclipsys partnership to jointly offer HIPAA services

Named by Gartner as one of top four HIPAA consulting companies with the most useable tools in the industry

Proven and replicable methodology

Over 30 dedicated HIPAA consultants with an average of 10 – 20 years of healthcare operations experience

HIPAA

HIPAA Clients

National

- Tenet HealthSystem
- Carondelet Health System
- Premier Sourcing Partners
- Triad Hospitals, Inc.
- CHRISTUS Health
- Eclipsys Corporation

Texas

- Texas Children's Hospital
- Memorial Hermann Healthcare System
- Parkland Health and Hospital System
- University Medical Center
- Shannon Healthcare System

California

- Citrus Valley Health Partners
- NorthBay Healthcare System
- Daughters of Charity Healthcare System

Others

- Central DuPage Health
- Integris Health
- Baptist Healthcare System
- Exempla Healthcare
- St. Jude Children's Research Hospital
- Pitt County Medical Center
- Sisters of Mercy
- Yale New Haven Health System
- Sparks Regional Medical Center
- Peninsula Regional Medical Center
- Central Georgia Health System
- Rapid City Health System
- St. Mary's, Pennsylvania
- St. Mary's, Georgia
- Wilson Medical Center

HIPAA

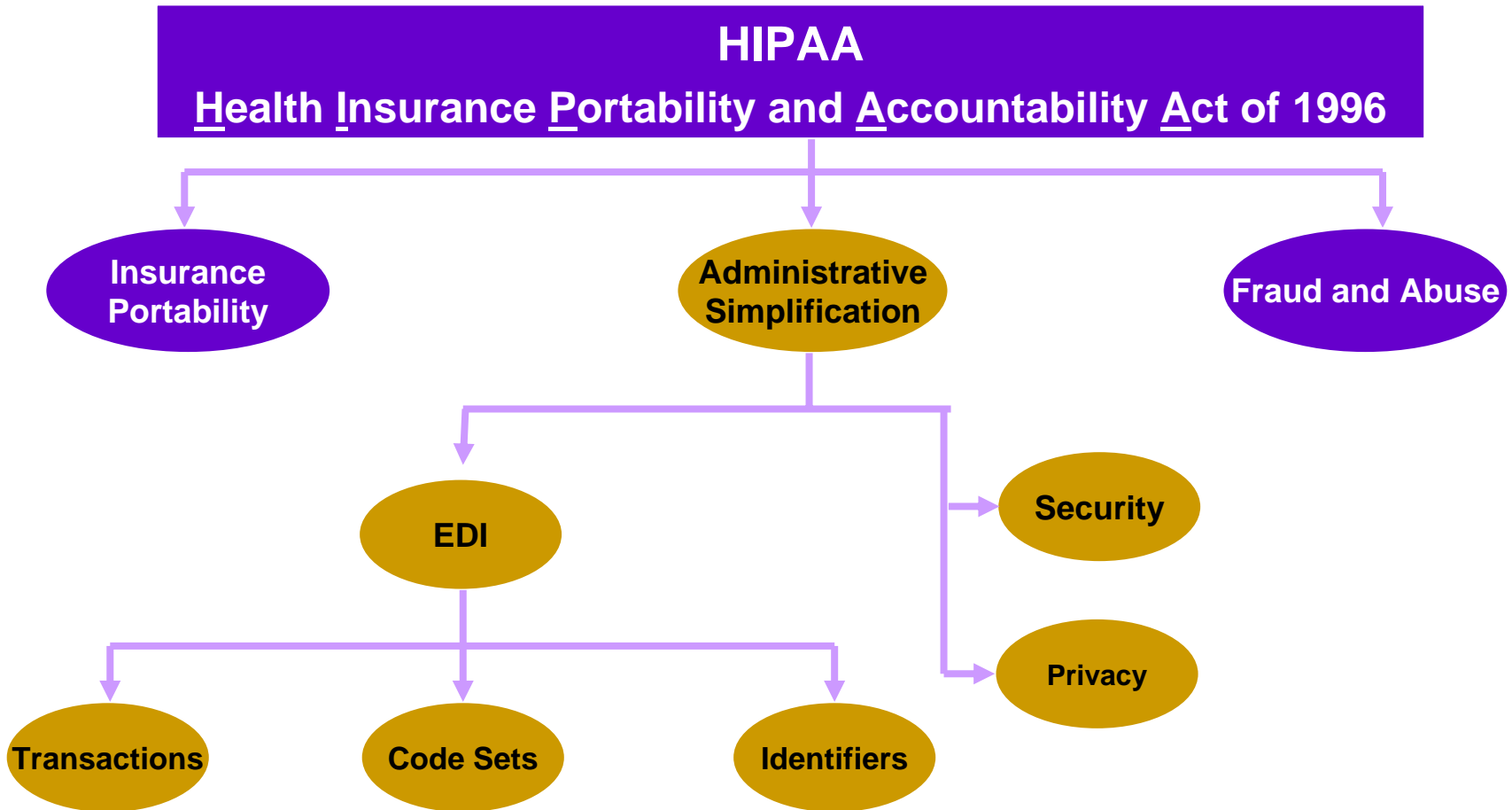

HIPAA

Healthlink's Approach to HIPAA Compliance Management

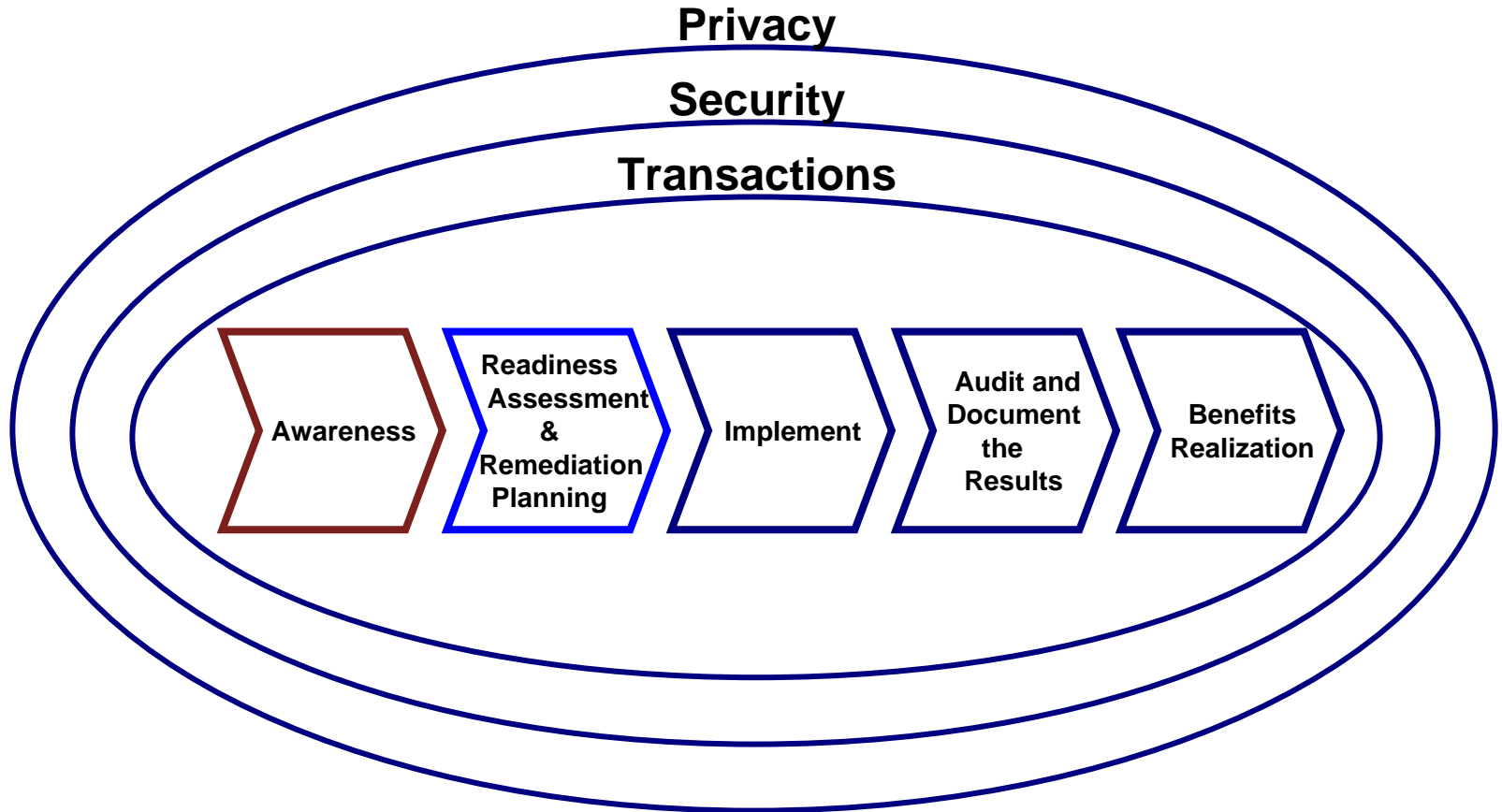

HIPAA

Case Study - Parkland Health and Hospital System and University Medical Center

Environment: County hospital (PHHS) and private hospital (UMC) located on UTSW Medical School campus

Approach: Outsourced assessment

Resulted in a gap analysis for:

- Transactions
- Security
- Privacy

Included high level remediation plan based on risk and current organizational strategies

HIPAA

Case Study - Tenet HealthSystem

Environment: 110-hospital national integrated health system

Approach: Project Management Office

Four dedicated resources to support HIPAA readiness efforts for duration of readiness efforts

- Vendor management
- Proprietary application transaction mapping
- Security policy and procedure development
- Privacy direction

HIPAA

Case Study - Triad Hospitals, Inc.

Environment: 48-hospital national integrated health system

Approach: Project Management Office

Dedicated resources to support HIPAA readiness efforts for duration of readiness efforts

- EDI best practices
- Vendor management
- Security policy and procedure development
- Privacy policy and procedure development
- Training
- Management of compliance efforts for health plans and physician practices

DynCorp

Dynamic. Dedicated. Driven.

Vision

Delivering value-added

solutions in Outsourcing

and Information Technology

to all of our customers

PKI

PKI

SPARTA

PRIDE IN PERFORMANCE

- **20-YEAR-OLD PROFESSIONAL SECURITY COMPANY**
- **800+ EMPLOYEES IN 17 U.S. LOCATIONS**
- **\$140M REVENUE IN FY 2001**
- **FOCUS EXCLUSIVELY ON INFO SYSTEM SECURITY ENGINEERING**

PKI

SPARTA

Major player in Federal Government PKI activities

- Participates in the Federal PKI Technical Working Group
- Participates in NSA/NIST sponsored Information Assurance Technical Forum (IATF)

Personnel Qualifications

- Trained to operate Certificate Authority Workstation
- Trained to perform Local Registration Authority duties
- Trained to install Certificate Authority procedures
- Many SPARTA employees have experience with secure e-mail using public key technology

PKI

Information Systems Security Engineering Process

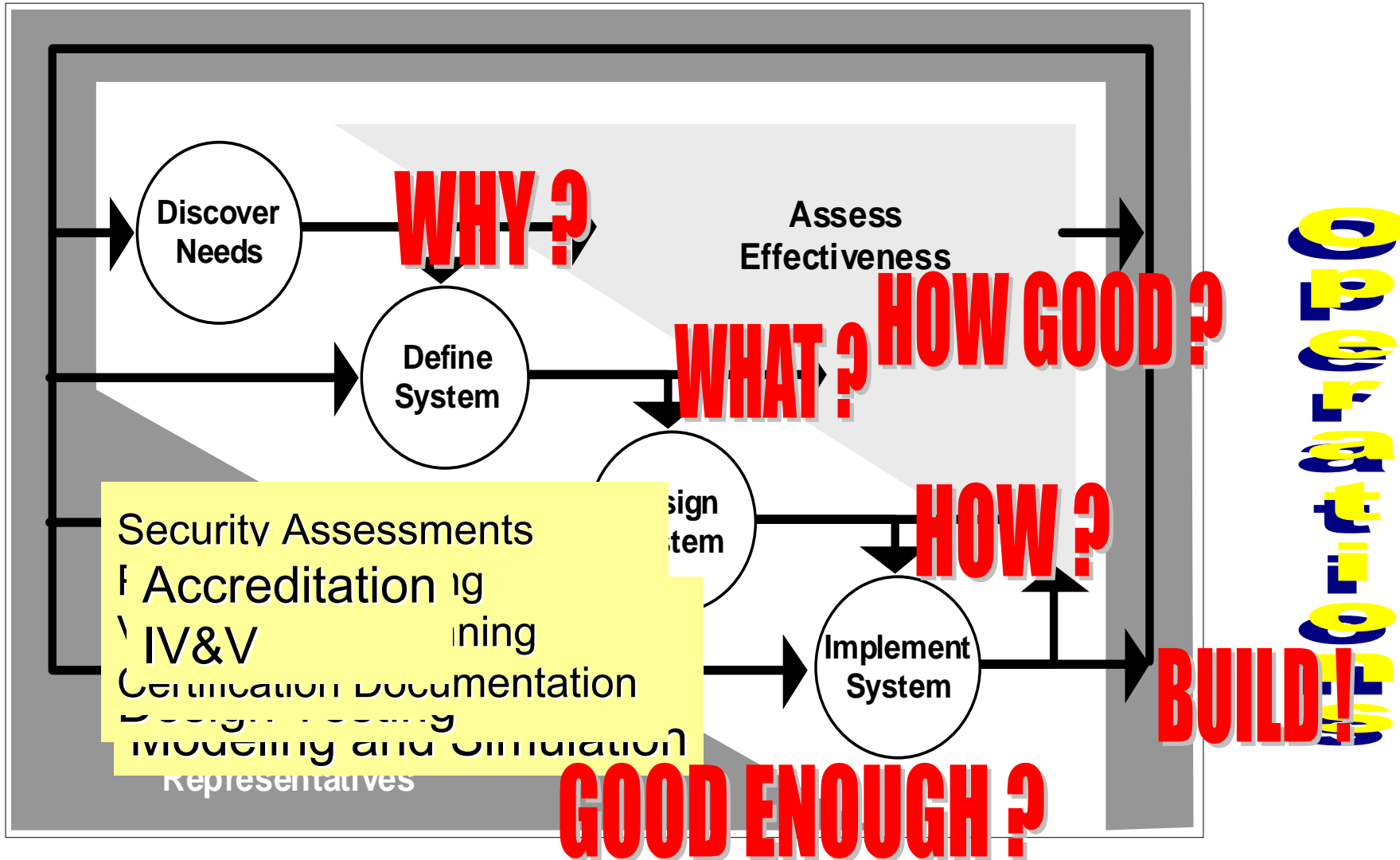

PKI

PKI Security Engineering

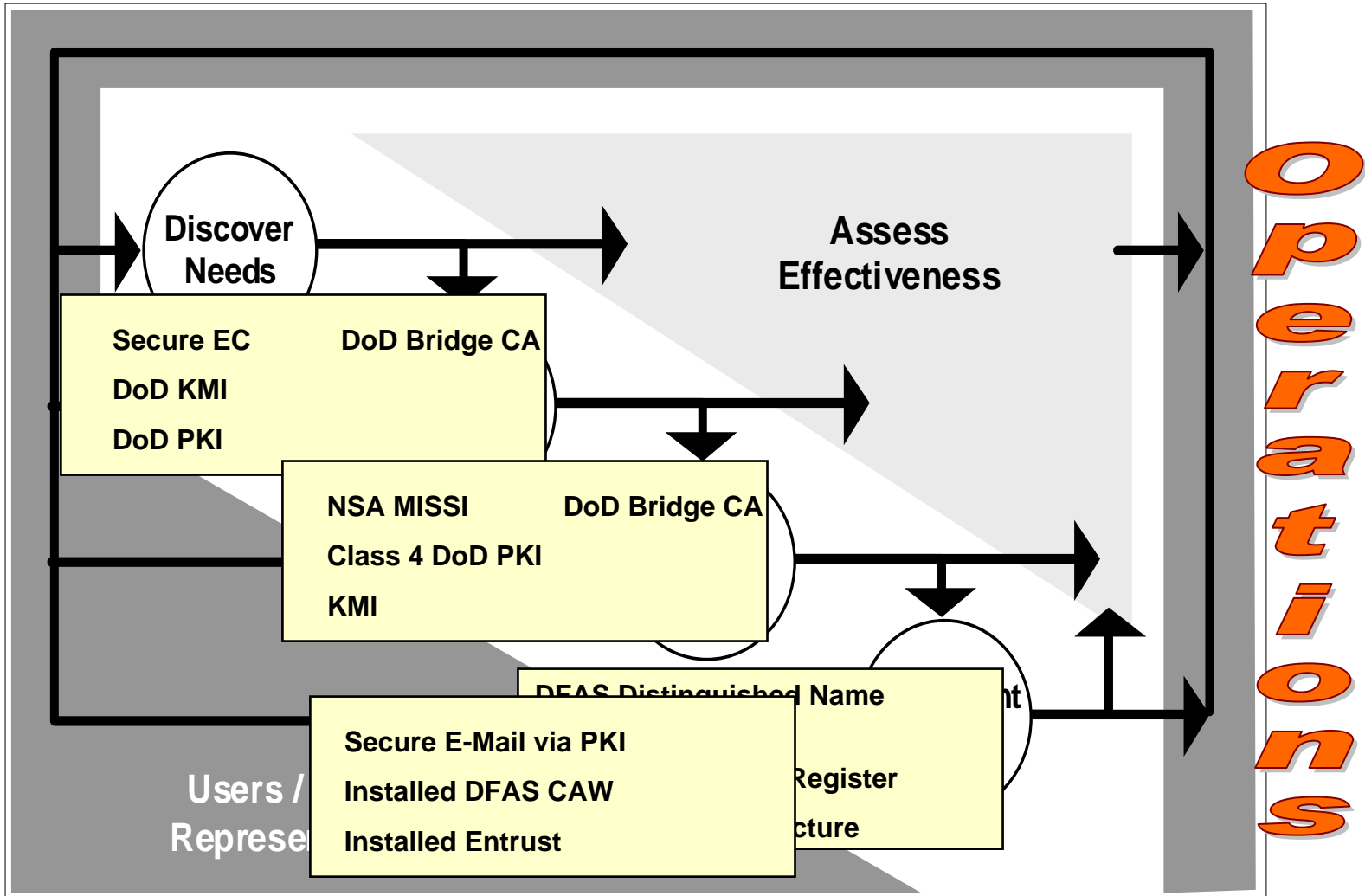

PKI

Case Study - Defense Finance and Accounting Service (DFAS) Security Integration

- Prepared information system security policy to embrace new Public Key Cryptographic Technology
- Helped determine which PKI security capabilities were needed and what priority should be applied to acquiring those capabilities
- Drafted PKI policy and implementation guidelines
- Designed the distinguished naming structure for DFAS in accordance with X.500 standards and the then current Federal Electronic Mail program
- Prepared plans for PKI component deployment, drafted DFAS CPS for managing CAWs
- Designed software API to allow DFAS PKI Registration to be automated (supported any DFAS electronic workflow)
- Demonstrated via software applications the use of public key cryptography for data integrity (digital signature) and identification and authentication
- Built prototype applications incorporating public key cryptography and three different types of security tokens (FORTEZZA PCMCIA Cards, Smart Cards, and software based certificate token)

DynCorp

Dynamic. Dedicated. Driven.

Vision

Delivering value-added

solutions in Outsourcing

and Information Technology

to all of our customers

Summary

DynCorp

Dynamic. Dedicated. Driven.

Vision

Delivering value-added

solutions in Outsourcing

and Information Technology

to all of our customers

Open Discussion