



UNITED STATES
 CONSUMER PRODUCT SAFETY COMMISSION
 4330 EAST WEST HIGHWAY
 BETHESDA, MD 20814

CPSC/OPC OF THE SECY
 FREEDOM OF INFORMATION

2008 JAN 11 A 11

BALLOT VOTE SHEET

Date: **JAN 11 2008**

TO : The Commission
 Todd Stevenson, Secretary

THROUGH: Patricia Semple, Executive Director *PS*

FROM : Lowell F. Martin, Acting General Counsel *L F Martin*
 Jeffrey R. Williams, Assistant General Counsel *JRW*
 Patricia M. Pollitzer, Attorney *PMP*

SUBJECT : Staff's Recommendation for Final Rule to Amend the Flammability Standard for Clothing Textiles

Ballot Vote Due: JAN 18 2008

Attached is a briefing package from the staff recommending that the Commission direct the Office of General Counsel ("OGC") to prepare a draft *Federal Register* notice for a final rule amending the Flammability Standard for Clothing Textiles, 16 C.F.R. part 1610, in accordance with the suggestions discussed in the staff's briefing package.

Please indicate your vote on the following options.

I. Direct OGC to prepare a draft *Federal Register* notice for the Commission's approval:

 Signature

 Date

II. Direct OGC to prepare a draft *Federal Register* notice terminating the rulemaking.

 Signature

 Date

CPSC/OPC OF THE SECY
 FREEDOM OF INFORMATION
 2008 JAN 11 A 11
 EXEMPTED BY PERMITS
 RULEMAKING ADMIN. PROC.
 ALL INFORMATION CONTAINED HEREIN IS UNCLASSIFIED
 DATE 1/11/08 BY [signature]

III. Take other action (please specify):

Signature

Date



**DRAFT FINAL RULE
UPDATING THE
FLAMMABILITY STANDARD
FOR CLOTHING TEXTILES
16 C.F.R. PART 1610**

BRIEFING PACKAGE

For further information contact:

Patricia K. Adair, Project Manager
Directorate for Engineering Sciences
Consumer Product Safety Commission
(301) 504-7536

NOTE: This document has not been
reviewed or accepted by the Commission.
Initial PA Date 1/14/08

~~CPSC HAS NOT CLEARED FOR PUBLIC~~
~~NOT FOR PUBLIC USE OR~~
~~PRODUCT IDENTIFIED~~
~~EXCEPT BY: PERITON~~
~~RULEMAKING ADMIN. PROC.~~
~~WITH PORTIONS REMOVED~~

TABLE OF CONTENTS

	<u>Page Number</u>
EXECUTIVE SUMMARY	4
BRIEFING MEMORANDUM	5
I. Introduction	5
II. Background	5
III. Staff Analysis of Comments Received on the Proposed Rule	7
IV. Final Regulatory Analysis	10
V. Discussion/Conclusions	10
VI. Options	11
VII. Recommendation	11
ATTACHMENTS	
TAB A 72 <i>Federal Register</i> 8844, "16 C.F.R. Part 1610 Standard for the Flammability of Clothing Textiles: Proposed Rule," February 27, 2007. .	12
TAB B Memorandum from David Miller, Directorate for Epidemiology, to Patricia Adair, Project Manager, November 15, 2007	38
TAB C Memorandum from Martha A. Kosh, Office of the Secretary, to ES, May 15, 2007.	46
TAB D Memorandum from Gail Stafford and Weiyang Tao, Directorate for Laboratory Sciences, to Patricia K. Adair, Project Manager, October 22, 2007.	48
TAB E Memorandum from John Murphy, Directorate for Engineering Sciences, Division of Mechanical Engineering, to Patricia K. Adair, Project Manager, November 16, 2007.....	55
TAB F Memorandum from Mary Toro, Office of Compliance and Field Operations, to Patricia K. Adair, Project Manager, September 5, 2007.....	57
TAB G Memorandum from Dale R. Ray, Directorate for Economic Analysis, to Patricia K. Adair, Project Manager, August 6, 2007.....	59

ACKNOWLEDGEMENTS
Clothing Textiles Standard Update Team

Marilyn Borsari, *Compliance*
Jacqueline Campbell, *Laboratory Sciences*
Terrance Karels, *Economics*
Shivani Mehta, *Engineering Sciences*
Allyson Tenney, *Engineering Sciences*
Dale Ray, *Economics*
Trey Thomas, *Health Sciences*

John Murphy, *Engineering Sciences*
Patricia Pollitzer, *General Counsel's Office*
Cassandra Prioleau, *Health Sciences*
Gail Stafford, *Laboratory Sciences*
Weiyang Tao, *Laboratory Sciences*
David Miller, *Epidemiology*
Sharon White, *Human Factors*

EXECUTIVE SUMMARY

Congress passed the Flammable Fabrics Act (FFA) of 1953 to prohibit the introduction or movement into commerce of highly flammable wearing apparel and fabrics. The FFA incorporated a voluntary standard, "Flammability of Clothing Textiles, Commercial Standard 191-53." The standard provides a test method and classification system for the flammability of textiles for apparel use. Codified in the Code of Federal Regulations at 16 C.F.R. Part 1610 as the *Standard for the Flammability of Clothing Textiles*, the standard establishes three classes of flammability, sets requirements for clothing textiles, and prohibits the manufacture, distribution and sale of dangerously flammable textiles for use in clothing.

The original standard was issued over 50 years ago. Consumer garment care practices have changed significantly and modern equipment has been developed since the standard became effective. In order to reflect current technologies, safe laboratory practices, and modern consumer care practices, the standard requires updating.

On September 12, 2002, the Commission issued an advance notice of proposed rulemaking (ANPR) to update the *Standard for the Flammability of Clothing Textiles* and solicit comments on the risk of injury, the regulatory alternatives under consideration, and other possible alternatives. The scope of the ANPR was limited to considering changes to the standard to reflect current consumer practices and modernized testing equipment, and to clarify several aspects of the standard. In response to the ANPR, commenters generally agreed that the standard needed to be updated to include modern testing apparatus, as well as refurbishing practices which reflect current consumer practices. Most, but not all, commenters said that only technical changes were needed. Some commenters suggested changes to the standard that would have gone beyond the scope of the ANPR.

On February 27, 2007, the Commission issued a notice of proposed rulemaking (NPR) to amend the *Standard for the Flammability of Clothing Textiles* and requested public comments on the proposed amendments. Comments received on the proposed amendments were generally supportive; several commenters suggested minor technical or editorial changes which the staff addressed in this briefing package.

The amendments updating 16 C.F.R. Part 1610 are not expected to have any significant economic effects on manufacturers, testing laboratories, consumers or other parties. This is because the amendments would keep current industry practices and procedures in place, while providing clarification on several aspects of the standard.

The staff recommends that the Commission direct the staff to prepare a draft *Federal Register* notice of a final rule to amend 16 C.F.R. Part 1610 *Standard for the Flammability of Clothing Textiles*, with minor technical and editorial changes from the NPR as discussed in this briefing package.



UNITED STATES
CONSUMER PRODUCT SAFETY COMMISSION
WASHINGTON, DC 20207

Memorandum

Date: JAN 11 2008

TO : The Commission
Todd Stevenson, Secretary

THROUGH: Lowell Martin, Acting General Counsel
for Patricia Semple, Executive Director

FROM : Robert J. Howell, Acting Assistant Executive Director
Office of Hazard Identification and Reduction
Patricia K. Adair, Project Manager
Directorate for Engineering Sciences

SUBJECT : Draft Final Amendments to the *Standard for the Flammability of Clothing Textiles*, 16 C.F.R. Part 1610

I. INTRODUCTION

On February 27, 2007, the U.S. Consumer Product Safety Commission (CPSC) proposed amendments to 16 Code of Federal Regulations (C.F.R.) Part 1610 *Standard for the Flammability of Clothing Textiles* (see **Tab A**). This memorandum provides a review of public comments received in response to the notice of proposed rulemaking¹ (NPR), and recommends the Commission issue the proposed amendments, with minor technical and editorial changes, on a final basis.

II. BACKGROUND

In 1953, Congress enacted the Flammable Fabrics Act (“FFA”), which prohibited the importation, manufacture for sale, or sale in commerce of any article of wearing apparel, which is “so highly flammable as to be dangerous when worn by individuals.” The FFA incorporated a voluntary standard, “Flammability of Clothing Textiles, Commercial Standard 191-53.” The standard provides a test method and classification system for the flammability of textiles for apparel use. Codified in the Code of Federal Regulations at 16 C.F.R. Part 1610 as the *Standard for the Flammability of Clothing Textiles*, the standard establishes three classes of flammability, sets requirements for clothing textiles, and prohibits the manufacture, distribution, and sale of dangerously flammable textiles for use in clothing.

¹ 72 *Federal Register* 8844, “16 C.F.R. Part 1610 *Standard for the Flammability of Clothing Textiles*: Proposed Rule,” February 27, 2007.

SEARCHED BY:
INDEXED BY:
EXEMPTED BY:
RELEASING AGENCY:
WITH PORTIONS REMOVED

NOTE: This document has not been reviewed or approved by the Commission.
Initial Date

Mortality data indicates that fires involving clothing ignition resulted in 120 fatalities annually during the most recent years for which data was available (2002-2004). Population fatality rates increased with age. In addition, an estimated 3,900 non-fatal injuries were treated in hospital emergency departments annually (2003-2005). Among these non-fatal injuries, 25 percent were severe enough to require admission to a hospital. More than 75 percent of the clothing fire-related non-fatal injuries involved some form of daywear (see *Tab B*).

Since the original standard became effective over 50 years ago, consumer garment care practices have changed and modern testing equipment has been developed. In order to reflect current technologies, safe laboratory practices, and modern consumer care practices, the standard requires updating.

In September 2002, the Commission issued an advance notice of proposed rulemaking² (ANPR) to update the *Standard for the Flammability of Clothing Textiles* and solicit comments on the risk of injury, the regulatory alternatives under consideration, and other possible alternatives. The scope of the ANPR was limited to considering changes to the standard to reflect current consumer practices and modernized testing equipment, and to clarify several aspects of the standard. The ANPR identified several sections of the standard that the staff believed should be updated and revised. These included the refurbishing (laundering and dry cleaning) portion of the standard and the description of the flammability test cabinet. In addition, the staff noted that large portions of the standard needed to be rewritten to make the test procedure easier to understand and follow.

In response to the ANPR, commenters generally agreed that the standard needed to be updated to include modern testing apparatus, as well as refurbishing practices which reflect current consumer practices. Most, but not all, commenters said that only technical changes were needed. Some commenters suggested changes to the standard that would have gone beyond the scope of the ANPR.

On November 30, 2006, staff forwarded a briefing package³ to the Commission recommending that the Commission direct the staff to issue a notice of proposed rulemaking (NPR) to amend the *Flammability Standard for Clothing Textiles*, 16 C.F.R. Part 1610. On February 27, 2007, the Commission issued an NPR to amend the *Standard for the Flammability of Clothing Textiles* and requested public comments on the proposed amendments be submitted by May 14, 2007, see *Tab A*.

In response to that request, the Commission received comments from eight organizations: STR (#1), the National Cotton Council (NCC) (#2), Bureau Veritas Consumer Products Services, Inc. (Bureau Veritas) (#3), China WTO/TBT National Notification & Enquiry Center (#4), the Procter and Gamble Company (P&G) (#5), Intertek North American Retail Initiative Consumer Goods (Intertek) (#6), the National Textile Association (NTA) (#7) and the American Apparel

² 67 *Federal Register* 57771, "16 C.F.R. Part 1610 Standard for the Flammability of Clothing Textiles: Advance Notice of Proposed Rulemaking," September 12, 2002.

³ Briefing Package. Project to Update/Amend the Flammability Standard for Clothing Textiles, 16 C.F.R. Part 1610. November 30, 2006. <http://www.cpsc.gov/LIBRARY/FOIA/FOIA07/brief/FlammStdsClothingTextile.s.pdf>-1711.5KB

and Footwear Association (AAFA) (#8), *see Tab C*. The comments on the proposed amendments were generally supportive and are discussed in the following section. Many of the commentors suggested minor technical or editorial changes. Some of the comments received in response to the NPR were the same as those received on the ANPR; as noted above, these comments recommended changes to the standard that were beyond the scope of the ANPR. These issues were generally addressed in the 2006 NPR briefing package.

III. STAFF ANALYSIS OF COMMENTS RECEIVED ON THE PROPOSED RULE

STR, NCC, P&G, NTA and AAFA reiterated their support for the proposed amendments and stated that, since the standard protects the general public, no changes were needed to the essential aspects of the standard.

A. Comments on Refurbishing (laundrying and dry cleaning).

STR, NCC and NTA commented that the new proposed language on the laundrying and dry cleaning portions of the standard is appropriate.

Bureau Veritas, China WTO/TBT National Notification & Enquiry Center, Intertek, and AAFA submitted several technical comments on the refurbishing (laundrying and dry cleaning) portion of the proposed rule. These included comments on the water temperature for laundrying, the ballast specified for dry cleaning, dry cleaning machine capacity, allowance for a “trial” or small dry cleaning machine, and referencing the most up-to-date version of the voluntary consensus standard, American Association for Textile Chemists and Colorists (AATCC) 124 *Appearance of Fabrics After Repeated Home Laundrying*.

Laundrying: One commenter stated that $60 \pm 3^{\circ}\text{C}$ is too hot and another recommended a washing temperature consistent with the original standard. Staff reviewed the proposed water temperature for the laundrying portion of the section and agrees that the wash temperature of $60 \pm 3^{\circ}\text{C}$ ($140 \pm 5^{\circ}\text{F}$) in the proposed rule is too hot. The hot water wash specified in the proposed rule could change the fabric structure of many fabrics, such as silks and rayons, and thus affect the flammability of the fabric. The current standard, which uses a hand wash procedure, specifies $95\text{-}100^{\circ}\text{F}$, with a rinse temperature of 80°F . Since the proposal specifies machine washing, staff does not agree that it is appropriate to use a temperature suited to hand washing. The draft final amendments specify a wash temperature of $49 \pm 3^{\circ}\text{C}$ ($120 \pm 5^{\circ}\text{F}$). Staff believes this temperature is hot enough to remove any water soluble finishes from the fabric which may affect its flammability characteristics and is appropriate for a machine wash.

The staff agrees that the most recent version of AATCC 124 should be referenced; the draft final amendments reference AATCC 124 – 2006.

Dry cleaning: China WTO/TBT National Notification & Enquiry Center recommended allowing the use of a “trial dry cleaner” rather than a commercial dry cleaning machine. The dry cleaning procedure in the proposed rule is similar but not identical to the procedure specified in ASTM D1230 *Standard Test Method for Flammability of Apparel Textiles*, section 9.2.1.6. Option B.

The ASTM D1230 refurbishing procedure was found by staff and ASTM Committee D13 (Textiles) to be as stringent as the procedure specified in 16 C.F.R. Part 1610.⁴ Because the dry cleaning method specified in the current standard cannot be performed in the United States due to environmental regulations, the industry and the CPSC staff have been using the procedure in ASTM D1230 section 9.2.1.6, Option B for many years. Staff does not have any data to indicate whether the use of a "trial dry cleaner" would be as stringent as the refurbishing procedure in ASTM D1230. Intertek asked that the amount of detergent to be used in the dry cleaning procedure be specified. The amount of detergent to be used in the dry cleaning procedure will depend on the capacity of the machine; this information is provided with the machine manufacturer's instructions.

Bureau Veritas, Intertek, and AAFA disagreed with the specified ballast (80% wool fabric pieces and 20% polyester fabric pieces) in the proposal. Upon further consideration, the staff has changed the specified ballast to 80% wool and 20% cotton to be consistent with internationally recognized dry cleaning standards, *see Tab D*.

Intertek and AAFA questioned the need to dry clean samples in a load that is 80% of the dry cleaning machine's capacity and suggested that the load should be 100% of the machine's capacity. Staff concludes that the International Fabricare Institute's recommendation of 80% capacity is appropriate for proper dry cleaning.

The Directorate for Laboratory Sciences (LS) reviewed and responded to all the comments on the refurbishing portion of the proposed amendment. For a full discussion of the refurbishing comments, *see Tab D*.

B. Comments on Definitions.

Several commenters made suggestions for changes to the definitions in the proposal. China WTO/TBT National Notification & Enquiry Center and Intertek requested clarification of "base burn," and Bureau Veritas suggested a change to the definition of "long dimension".

Staff considers the proposed definition of "base burn" to be sufficiently clear. The definition includes specific burning characteristics that must be observed during and after each test in order to distinguish between a base burn at point of ignition and the type of base burn used to establish a Class 3 fabric, where the base burn starts at places on the specimen other than the point of flame impingement as a result of surface flash.

Bureau Veritas suggested changing the "long dimension" definition to "the 150mm (6 inch) length of test specimen (cut with the 6" dimension in the same orientation of the worst burning direction of the overall fabric)." Staff does not agree because the long dimension is not always in the fastest burning direction of the fabric. For example, when preparing preliminary test specimens to determine the fastest burning direction of a plain surface textile fabric, the 6 inch length of each specimen will be in a different fabric direction.

⁴ Letter to Don Knodel, Chairman of ASTM Subcommittee D13.52 Flammability, from Linda Fansler, ES, June 1993.

In addition, Intertek requested that a definition for “coated fabrics” be added to section 1610.33(a)(2). Staff agrees and has added the definition for “coated fabrics” from ASTM D123-07 *Standard Terminology Relating to Textiles*.

Comments on the definitions are more fully discussed in the LS memo, *see Tab D*.

C. Comments on the Test Procedure.

Several comments were received on the test procedure; these included the conditioning requirements for cotton, preliminary testing, and brushing.

P&G suggested that cotton fabrics, being hydrophilic, should be tested in standard humidity rather than be subject to the conditioning oven and dessicator at 0% humidity. P&G notes the proposed conditions are more stringent than likely “real world” conditions and those specified in two international textile test methods.⁵ Staff realizes that cotton responds quickly to changes in humidity, but concludes that testing cotton and cotton containing fabrics under the more severe atmospheric conditions in the current standard provides a greater level of safety than testing under standard textile testing conditions. Therefore, the staff has not changed the conditioning requirements.

Intertek commented that the procedure for selecting test specimens in §1610.6(a)(3)(i), *Raised surface textile fabrics – (i) Preliminary trials* is confusing. Staff has reviewed this language and concludes that this procedure is properly explained in the proposed rule; thus, the staff has not changed the language in the draft final rule. In addition, Intertek asked if there is a specific rate to be used when brushing raised fiber surface textile fabrics. The standard specifies only that the specimen be brushed at a uniform rate; no change was made in the proposal.

Comments on the test procedure are addressed in detail by LS, *see Tab D*.

D. Comments on the Test Apparatus and Materials.

Several comments were received on the test apparatus and materials. Several commenters on the ANPR discussed the need for testing laboratories to be allowed to use more modern versions of the flammability test chamber. In the proposed amendments, the staff worked to achieve a balance between providing an appropriate description of the flammability test chamber, along with figures, without providing prescriptive requirements that would have limited the test chamber to a specific make and model. In response to the NPR, Intertek asked that more detailed information on the flammability test cabinet be specified in the standard. The draft final amendments provide additional details, including manufacturing tolerances and descriptive language, which the staff believes will be helpful but will not limit or discourage the use of modern equipment.

⁵ ISO 6940-2004 *Textile fabrics -- Burning behaviour -- Determination of ease of ignition of vertically oriented specimens*, and ISO 6941-2003 *Textile fabrics -- Burning behaviour -- Measurement of flame spread properties of vertically oriented specimens*.

Comments on the test apparatus and materials are addressed in detail by LS, *see Tab D*, and by the Directorate for Engineering Sciences, Division of Mechanical Engineering, *see Tab E*.

E. Comments on Exemptions, Reasonable and Representative Testing, and the Standard's Applicability to Specific Apparel Items.

A comment from China WTO/TBT National Notification & Enquiry Center asked what the justification was for the 2.6 oz/yd² exemption for all plain surface fabrics and asked for the historical information that formed the basis for the exemption. The commenter further requested that, if that information could not be provided, the exemption be lowered to 2.0 oz/yd². This information can be found at 49 *Federal Register* 242, December 14, 1984; 16 C.F.R. Part 1610 *Standard for the Flammability of Clothing Textiles; Requirements for Testing and Recordkeeping to Support Guaranties*. No change has been made to the exemptions.

China WTO/TBT National Notification & Enquiry Center also asked for clarification about the standard's applicability to scarves. The proposed amendments, like the current 16 C.F.R. Part 1610, apply to scarves, *see Tab F*.

Bureau Veritas asked that the standard provide further guidance on reasonable and representative testing. Guidance on developing a reasonable and representative testing program was issued by the Commission in 1998 and can be found at 63 *Federal Register* 42697, August 11, 1998; *Policy Statement – Reasonable and Representative Testing to Assure Compliance with the Standard for the Flammability of Clothing Textiles*, *see Tab F*.

IV. FINAL REGULATORY ANALYSIS

The final regulatory analysis prepared by the Directorate for Economic Analysis (EC) (*see Tab G*) concludes that, if the Commission promulgated the proposed amendments to the flammability standard for clothing textiles, the amendments would not be expected to have any significant economic effects on manufacturers, testing laboratories, consumers, or other parties. This is because the amendments would keep current industry practices and procedures in place, while providing clarification on several aspects of the standard.

V. DISCUSSION/CONCLUSIONS

Comments received on the proposed update to 16 C.F.R. Part 1610 were generally supportive. The purpose of the proposed amendments is to modify the current procedures only as necessary to reflect the existence of modern equipment and current consumer care practices, and to provide clarification on several aspects of the standard. The staff observes that this proceeding does not include any proposal to change the classification criteria of the clothing textiles standard or provide for changes to the exemptions to the standard.

As noted in Section IV above, the amendments updating 16 C.F.R. Part 1610 are not expected to have any significant economic effects on manufacturers, testing laboratories, consumers, or other parties.

VI. OPTIONS

- a. Direct the staff to prepare a draft *Federal Register* notice of a final rule to amend 16 C.F.R. Part 1610 *Standard for the Flammability of Clothing Textiles* in accordance with the staff recommendation.
- b. Make no change to amend 16 C.F.R. Part 1610 *Standard for Flammability of Clothing Textiles* and direct the staff to prepare a draft *Federal Register* notice terminating the rulemaking.

VII. RECOMMENDATION

The staff recommends that the Commission direct the staff to prepare a draft *Federal Register* notice of a final rule to amend 16 C.F.R. Part 1610 *Standard for the Flammability of Clothing Textiles*, with minor changes from the NPR as discussed in this briefing package.

TAB A



Federal Register

Tuesday,
February 27, 2007

Part II

Consumer Product Safety Commission

16 CFR Part 1610
Standard for the Flammability of Clothing
Textiles; Proposed Rule

**CONSUMER PRODUCT SAFETY
COMMISSION**

16 CFR Part 1610

**Standard for the Flammability of
Clothing Textiles; Notice of Proposed
Rulemaking**

AGENCY: Consumer Product Safety Commission.

ACTION: Notice of proposed rulemaking.

SUMMARY: The Commission is proposing to amend its flammability standard of general wearing apparel, the Standard for the Flammability of Clothing Textiles, 16 CFR part 1610. The Standard, originally issued in 1953, has become outdated in several respects. The Commission is proposing changes to better reflect current consumer practices and technologies and to clarify several aspects of the Standard.

DATES: Written comments must be received by May 14, 2007. Requests to make an oral presentation must be received by April 13, 2007.

ADDRESSES: Written comments should be filed by e-mail to cpssc-os@cpssc.gov. Comments also may be filed by telefacsimile to (301) 504-0127, or they may be mailed or delivered, preferably in five copies, to the Office of the Secretary, Consumer Product Safety Commission, Room 502, 4330 East West Highway, Bethesda, Maryland 20814-4408; telephone (301) 504-7923. Comments should be captioned "Clothing NPR."

The public may also request an opportunity to present comments orally. Such requests should be submitted to the Office of the Secretary by e-mail, mail, fax or in person at the addresses or phone numbers listed above.

FOR FURTHER INFORMATION CONTACT: Patricia K. Adair, Directorate for Engineering Sciences, Consumer Product Safety Commission, 4330 East West Highway, Bethesda, Maryland 20814-4408; telephone (301) 504-7536.

SUPPLEMENTARY INFORMATION:

A. Background

1. History of the Standard

It excludes footwear, interlining fabrics, and some hats and gloves. The standard provides a test to determine whether such clothing and fabrics exhibit "rapid and intense burning," and are therefore highly flammable.

In 1953, Congress enacted the Flammable Fabrics Act of 1953 ("FFA"), (Pub. L. 83-88, 67 Stat. 111). As enacted in 1953 and amended in 1954, the FFA prohibited the importation, manufacture for sale, or the sale in commerce of any

article of wearing apparel, which is "so highly flammable as to be dangerous when worn by individuals." The FFA of 1953 specified that a test, first published by the Department of Commerce as a voluntary commercial standard, then called "Flammability of Clothing Textiles, Commercial Standard ("CS") 191-53," shall be used to determine if fabric or clothing is "so highly flammable as to be dangerous when worn by individuals."

In 1967, Congress amended the FFA, expanding its coverage and authorizing the Secretary of Commerce to issue flammability standards through rulemaking. A savings clause kept the flammability standard for clothing textiles that the 1953 Act had mandated in effect until superseded or modified by the Secretary of Commerce through the procedures specified in the 1967 amendment. See section 11 of Pub. L. 90-189, 81 Stat. 568, December 14, 1967.

In 1972, Congress established the Consumer Product Safety Commission when it enacted the Consumer Product Safety Act ("CPSA"), 15 U.S.C. 2051 *et seq.* The CPSA transferred to the Commission the authority the Secretary of Commerce had to issue and amend flammability standards under the FFA. 15 U.S.C. 2079(b). In 1975, the Commission published the FFA of 1953 at 16 CFR 1609 and codified the Standard for the Flammability of Clothing Textiles at 16 CFR part 1610.

2. The Current Standard

Most fabrics are combustible. Some combustible fabrics, when used for clothing are potentially dangerous to the wearer because of the speed and intensity of flame with which those fabrics burn and their ease of ignition and because of the design of the garment. The Standard sets out a method for measuring burn time, which is a function of ease of ignition and flame spread rate.

The Commission is not proposing to change the essential aspects of the Standard, but rather to update and clarify it. The Standard describes a test apparatus and the procedures for testing clothing and textiles intended to be used for clothing. It establishes three classes of flammability. The classes are based on measurement of burn time, along with visual observations of flame intensity. The classes are: Class 1 or normal flammability; Class 2 or intermediate flammability; and Class 3 or rapid and intense burning. Clothing and textiles that are categorized as Class 3 under the prescribed test method are considered dangerously flammable. 16 CFR 1610.3.

To determine the appropriate classification, the Standard prescribes the method of testing. Five specimens are subjected to a flammability tester. This is a draft-proof ventilated chamber containing an ignition medium, a sample rack and an automatic timing device. *Id.* 1610.4(b). The ignition medium is a motor driven gas jet around a 26-gage hypodermic needle. *Id.* 1610.4(b)(6). A swatch of each sample must be subjected to the dry cleaning and hand washing procedure prescribed by the Standard. *Id.* 1610.4(d)&(e). To determine results, the average time of flame spread is taken for five specimens. However, if the time of flame spread is less than 4 seconds (3½ seconds for plain-surfaced fabrics), five additional specimens must be tested and the average time of flame spread for these ten specimens, or for as many of them as burn, must be taken. *Id.* 1610.4(g)(7). Classification is based on the reported results before and after drycleaning and washing, whichever is lower. *Id.* 1610.4(g)(8).

3. The Products

The products regulated under the Standard are clothing and fabrics intended to be used for clothing. The Standard applies to all items of clothing, and fabrics used for such clothing, whether for adults or children, for daywear or nightwear. The Commission has other regulations governing the flammability of children's sleepwear, 16 CFR parts 1615 and 1616, that are more stringent than the general wearing apparel flammability standard. The proposed changes discussed in this notice would not affect the children's sleepwear standards.

4. The Risk of Injury

Fatalities where clothing was the first item ignited have declined from 311 fatalities in 1980 to 110 fatalities in 2003, the most recent year of available data. An average of 122 clothing fire-related fatalities occurred annually during 1999-2003. Population fatality rates increased with age. In addition, an estimated 3,822 non-fatal injuries were treated in hospital emergency departments annually (2000-2004). Among these non-fatal injuries, 25 percent were serious enough to require admission to a hospital (compared to 5% for all consumer products). The changes the Commission is proposing will better reflect current practices and technologies and clarify some aspects of the Standard. These changes should improve the Standard's ability to address the risk of injury.

B. Statutory Provisions

The FFA sets forth the process by which the Commission can issue or amend a flammability standard. The Commission first must issue an advance notice of proposed rulemaking ("ANPR") which it did on September 12, 2002, 67 FR 57770.

The Commission is now issuing a notice of proposed rulemaking ("NPR"). As required, this notice contains the text of the proposed rule along with alternatives the Commission has considered and a preliminary regulatory analysis. 15 U.S.C. 1193(i). Before issuing a final rule, the Commission must prepare a final regulatory analysis, and it must make certain findings concerning any relevant voluntary standard, the relationship of costs and benefits of the rule, and the burden imposed by the regulation. *Id.* 1193(j). In addition, the Commission must find that the standard (1) is needed to adequately protect the public against the risk of the occurrence of fire leading to death, injury or significant property damage, (2) is reasonable, technologically practicable, and appropriate, (3) is limited to fabrics, related materials or products which present unreasonable risks, and (4) is stated in objective terms. 15 U.S.C. 1193(b).

The Commission also must provide an opportunity for interested persons to make an oral presentation before the Commission may issue a final rule. *Id.* 1193(d). The Commission requests that anyone who would like to make an oral presentation concerning this rulemaking please contact the Commission's Office of the Secretary (address is provided in the ADDRESSES section of this notice) within 45 days of publication of this notice. If the Commission receives requests to make oral comments, a date will be set for a public meeting for that purpose and notice of the meeting will be provided in the *Federal Register*.

C. Proposed Revision

To reflect changes in consumer garment care practices and to make the standard easier to understand, the Commission is proposing certain changes to the clothing flammability standard. These are discussed below.

Definitions. Over the years people have expressed confusion over the meaning of certain terms and a lack of defined terminology in the Standard. In particular, the meaning of the terms "base burn" and "surface flash" have caused confusion in interpreting and reporting test results for raised surface textile fabrics. These terms are now defined in the proposal. In addition,

several other relevant terms and definitions have been added. These terms include *burn time, dry cleaning, flammability, flame, ignition, interlining, laundering, long dimension, plain surface textile fabric, raised surface textile fabric, refurbishing, sample, specimen, and stop thread supply.*

Changes to the flammability tester. The test chamber prescribed in the current Standard uses a mechanical timing mechanism and is no longer available for purchase. Apparel manufacturers and testing laboratories currently use more modern flammability test chambers that incorporate electro-mechanical components to apply the ignition flame and measure burn time. (The Standard allows alternate procedures if they are as stringent as the specified procedure.) A variety of such testers are available from a number of manufacturers. The proposed revision describes the critical parameters of a modern flammability test apparatus and provides diagrams. In 1982, CPSC staff conducted some work comparing the flame impingement time of the electrical test chamber to that of a chamber with the mechanical timing device and found that the electrical test chamber readings were comparable to and more consistent than the manual test chamber readings. The proposed revisions expressly permit the use of electro-mechanical devices to control and apply the flame impingement.

Refurbishing methods. The Standard requires fabrics to be refurbished, that is, dry cleaned and laundered, one time before testing. The purpose of this requirement is to remove any non-durable solvent or water soluble treatment present on the fabric. It is not intended to replicate how the garment would be used or cared for by a consumer. Both the dry cleaning and laundering procedures prescribed by the current Standard are outdated. The proposal revises these procedures to better reflect modern techniques for laundering and dry cleaning.

The method of dry cleaning that the current Standard prescribes requires perchloroethylene in an open vessel. However, perchloroethylene has been shown to cause cancer in animal tests, and use in this manner violates regulations issued by the Environmental Protection Agency. The Commission staff has not used this procedure since 1986. (The Standard allows alternate procedures if they are as stringent as the specified procedure.) Industry and independent laboratories have been using an alternative dry cleaning procedure provided in ASTM D 1230, Standard Test Method for Apparel

Flammability. This procedure uses perchlorethylene in a closed environment commercial dry cleaning machine for one cycle. Analysis of test data from an ASTM interlaboratory round robin indicates that this procedure is as stringent as the procedure currently specified in 16 CFR part 1610. However, the ASTM standard lacks specifications for solvent type, detergent class, cleaning and extraction time, drying time and temperature, and cool down/deoderization time. If specific and uniform conditions are not followed, test results could vary. Therefore, the proposed revision includes specific parameters for these conditions. These parameters were suggested by the International Fabricare Institute, a trade association for the professional garment care industry.

The current Standard requires that after fabric samples are dry cleaned they must be hand washed with neutral chip soap and line dried before testing them for flammability. 16 CFR 1610.4(e). However, neutral chip soap is no longer available. Most detergents are now non-phosphate based due to environmental concerns. The proposed revision sets forth laundering requirements based on those prescribed in American Association of Textile Chemists and Colorists ("AATCC") 124-2001, Appearance of Fabrics After Repeated Home Laundering. An earlier version of this test method was incorporated into other FFA standards in 2000. 65 FR 12924, 12929, and 12935 (March 10, 2000).

Test procedures. Over the years, manufacturers and testing laboratories have expressed confusion regarding the test procedures and materials or equipment required by the Standard. Inaccurate sample preparation and conditioning undermine the efficacy of the Standard. In the ANPR, the Commission identified confusing sections of the test procedure, including the instructions for selecting the surface or direction of the fabric to be tested, and the directions for determining when to test five additional specimens. The proposed revision reorganizes and rewrites the test procedure in a more logical step-by-step fashion to clarify the directions for selecting the surface or direction of the fabric to be tested, how to determine when testing five additional specimens is necessary, as well as how to conduct the flammability test.

Test result interpretation and reporting. The current Standard provides no codes to report complex test results consistently. Although this is not an issue for plain surface textile fabrics, it is for raised surface textile fabrics, the

classification of which is more complex. The proposed revision clarifies the instructions for calculating burn times and establishing the occurrence of a base burn (§ 1610.8). By defining the terms "base burn" and "surface flash" in § 1610.2, the proposed revision provides further clarification for the reporting of test results for raised surface textile fabrics. The proposed revision also specifies test result codes. These codes come from CPSC's laboratory test manual and are based on codes developed by the Federal Trade Commission many years ago. Uniform result codes will facilitate reporting accuracy and consistency, understanding of flammability performance, and resolution of test result differences among laboratories.

Subpart B and Subpart C. The Commission is also proposing changes to subparts B and C of the Standard. To reduce confusion, the proposal moves some provisions concerning procedures for conducting the tests that are currently in subpart B and C into subpart A. This should provide a more cohesive and clearer standard. Subpart C is substantially the same, but some language has been clarified to make it more consistent with subparts A and B, and the section describing the history of the FFA and the Standard has been removed.

D. Response to Comments on the ANPR

On September 12, 2002, the Commission published an ANPR initiating this rulemaking. 67 FR 57770. The Commission received 18 written comments from businesses, trade associations, and interested parties representing various segments of the fiber, textile and apparel industries, as well as academic institutions and fire service organizations. Commenters generally agreed that the Standard needs to be updated and reorganized. Specific issues raised by the comments are discussed below.

1. Laundering and Dry Cleaning

a. Comment. One commenter suggested considering new dry cleaning methods/solvents as an alternative to perchloroethylene.

Response. The Commission recognizes that new dry cleaning technologies have emerged in recent years as alternatives to perchloroethylene and that at least one region of the country is moving to phase-out the use of perchloroethylene by 2020. At this time, however, approximately 70% of U.S. dry cleaners still use perchloroethylene. Perchloroethylene is known to be slightly more severe in solvent action

than other solvents and more likely to remove any flame retardant treatments on textiles. The proposal specifies a "normal" commercial dry cleaning method which includes specifications for cleaning, extraction, drying temperature, drying time and cool down/deodorization. Samples are to be cleaned in a commercial dry cleaning machine, using perchloroethylene as the solvent in a closed environment.

b. Comment. One commenter expressed concern over the role of fabric softeners in fabric flammability.

Response. According to the Procter and Gamble Company, about 71% of U.S. households have some form of fabric softener. The most common forms of fabric softeners for home laundering are liquid softeners (purchased by 42% of U.S. households) and dryer-added sheet softeners (purchased by about 49% of U.S. households). Dryer sheet softeners have anti-static properties. Some households use both forms; some consumers use both a rinse cycle softener and a dryer sheet softener for the same load of laundry. At the present time there is no "standard reference" fabric softener. The AATCC technical committee RA88 on Home Laundering Technology is working on the development of a standard reference fabric softener; the technical committee estimates that this work may be completed in approximately three years. The Commission is not including a requirement for fabric softener at this time since there is no standard fabric softener to reference.

c. Comment. For changes to the dry cleaning and laundering procedures, two commenters suggested CPSC consider current AATCC and ASTM standards.

Response. The proposal incorporates certain sections of AATCC Test Method 124-2001 "Appearance of Fabrics After Repeated Home Laundering," consistent with other FFA regulations (16 CFR Parts 1615, 1616, 1630, 1631 and 1632). The dry cleaning procedure in the proposal is similar but not identical to ASTM D1230 Standard Test Method for Flammability of Apparel Textiles section 9.2.1.6 Option B. The proposal has specifications for dry cleaning in a commercial dry-cleaning machine using perchloroethylene in a "normal" cycle.

d. Comment. One commenter provided suggestions for updating the laundering method which included increasing the number of cycles.

Response. The intent of the laundering and dry cleaning requirements of the Standard is to remove any non-durable flame retardant treatments that may be on the clothing textile; its intent is not to replicate the

consumer's refurbishing practices. No change has been made; one cycle of each refurbishing method is required.

e. Comment. One commenter suggested requiring only the refurbishing method on the garment care label.

Response. The Standard applies to fabrics and fabrics used in garments. While the test method can be used to test fabric in the garment stage it also applies to fabric before it is sewn into a garment, so a fabric care label may not be present. The refurbishing requirement (laundering/dry cleaning) is to remove any solvent or water soluble treatment that might be on the garment. It is not meant to test the durability of fabric treatments over the lifetime of a garment.

2. Clarifications in the Standard

a. Comment. Several comments suggested areas of the Standard in need of clarification. These included clarifying the brushing of the specimens, fabrics considered to be raised fiber textiles, determination of the nap direction of raised surface textiles, exemptions allowed and interpretation of test results for classification.

Response. The Commission agrees that sections of the current Standard are difficult to interpret and need clarification, including clearer instructions on brushing of raised fiber surface textiles and determination of which fabrics are considered to have raised fiber surfaces. The proposal includes examples of raised fiber surface textiles and provides guidance on testing these fabrics. The proposal moves language from footnotes into the body of the Standard to clarify the exemptions allowed and brings forward clarifying language from 16 CFR subparts B and C. In addition, the proposed revision includes new text and graphics on the test procedure, interpretation of test results for classification, and engineering diagrams of the flammability test apparatus.

b. Comment. Commenters suggested adding portions of the CPSC laboratory test manual to clarify the test procedures in the Standard.

Response. The staff used the 1981 CPSC laboratory manual as a resource in developing recommendations to amend the Standard. The proposal has added language from the lab manual in many sections.

c. Comment. One commenter suggested that the terms "surface flash" and "base burn" be defined in the Standard; another suggested definitions for these terms.

Response. The proposal adds many new definitions to the Standard, including definitions for "surface flash" and "base burn" to facilitate clearer understanding of the flammability test, classification criteria and reporting results.

d. *Comment.* Two commenters suggested reorganizing the Standard to eliminate duplication.

Response. The Commission agrees and proposes to reorganize large portions of the Standard to eliminate duplication and make it easier to follow and understand.

3. Enforcement and Procedural Issues

a. *Comment.* Two commenters urged CPSC to continue with enforcement of 16 CFR part 1610.

Response. The CPSC Office of Compliance actively enforces 16 CFR part 1610 and continues to see violations of the Standard. From 1995 through June 2006, the Commission announced the recall of 28 apparel products for violations of 16 CFR part 1610.

b. *Comment.* One commenter suggested CPSC should consider promulgating a procedure or mechanism that allows the agency to make technical changes to this and other standards on a routine basis when referenced voluntary standards are upgraded by AATCC and ASTM (e.g., laundering and dry cleaning) without having to go through full notice and comment rulemaking.

Response. For any change by a voluntary standards organization to have the force and effect of a Commission rule, the Commission must formally adopt it through notice and comment rulemaking.

c. *Comment.* Some commenters suggested that the requirements of the Standard should be made more stringent to improve the level of safety provided by the Standard; comments included reviewing the appropriateness of the ignition source and ignition time, increasing the ignition time from 1 to 5 seconds, revising the acceptable burn times; considering forced ignition, ignition of the lower cut edge of the specimen and horizontal and vertical test configurations. One comment was concerned with the need for new flammability requirements for certain types of clothing (adult sleepwear and bathrobes). One commenter suggested adding a list of "suspect fabrics" and requiring more frequent testing for these fabrics. Additional comments included clarifying or amending the exemptions from the requirements for testing to support warranties and warning labels for "high-risk" garments.

Response. The scope of the ANPR issued on September 12, 2002 was limited to considering changes to the Standard to better reflect current consumer practices, modernized testing equipment and clarifying several aspects of the Standard. If, in the future, the Commission should determine that substantive changes to the Standard are needed to adequately protect the public, it would begin a separate proceeding for issuing a new standard or amending the current one in accordance with provisions of section 4 of the FFA (15 U.S.C. 1193).

4. The Desiccant Specified in the Standard

Comment. One commenter recommended specifying silica gel as the desiccant instead of anhydrous calcium chloride. Another commenter was concerned about the potency of the anhydrous calcium chloride desiccant and consequently the efficacy of testing. That commenter noted that the only way to ensure the potency of anhydrous calcium chloride desiccant is to require maintaining daily logs detailing the initial temperature and humidity readings inside the desiccator at the start of each day, as well as after each test is completed.

Response. The Commission agrees with the commenters, and the proposal specifies silica gel as the preferred desiccant. Silica gel is recognized as an effective, reliable desiccant; and it can be reactivated by heating, thus making it economical. Other FFA standards (16 CFR parts 1615, 1616, 1630 and 1631) specify silica gel as the preferred desiccant, and for the purpose of uniformity the CPSC laboratory has been using silica gel as the desiccant for all FFA testing since 1973. Regarding the potency of the desiccant, unlike anhydrous calcium chloride desiccant, the color-changing silica gel indicator provides a visual indication that the desiccant has become saturated with moisture. When the indicating silica gel crystals change color, the desiccant is reactivated by heating it in a laboratory oven.

5. Preliminary Tests

a. *Comment.* One commenter recommended eliminating the preliminary tests requirement because the majority of apparel garments are cut in the lengthwise direction, therefore only the lengthwise direction of a garment or fabric needs to be tested.

Response. When a garment is worn on a body, the orientation of the fabric varies. The standard specifies that the long dimension of a plain surface textile fabric specimen is that direction in

which the fabric burns most rapidly. To determine which fabric direction burns the most rapidly, the Standard requires preliminary tests of specimens cut in different directions. Because there can be differences in the burning characteristics with respect to fabric direction, the staff believes that the requirement for preliminary tests should not be eliminated.

b. *Comment.* One commenter suggested increasing the number of preliminary tests, especially for raised fiber surface textile fabrics to include both lengthwise and crosswise directions. The commenter is concerned about low-pile fabrics where it may be difficult to determine the correct direction of the raised surface fibers.

Response. For raised fiber surface textile fabrics the Standard requires the direction of the lay of the surface fibers be parallel with the long dimension of the specimen. Selecting specimens in this manner allows for the brushing procedure to raise the surface fibers, since the specimen is brushed against the direction of the lay of the surface fibers. The Standard requires tests of the most flammable surface of the fabric. With many raised fiber surface textile fabrics it is easy to determine the direction of the lay of the surface fibers by touch and visual observation, and preliminary tests are not needed. Regarding those fabrics where it may be difficult to visually determine the correct direction of the lay of the raised surface fibers, preliminary tests should be done to determine the direction with the fastest burning time. Since the Standard already requires preliminary tests to determine the most flammable fabric direction, there is no need to prescribe preliminary tests of both the lengthwise and crosswise direction of raised fiber surface textile fabrics.

6. Reporting Test Results

Comment. One commenter recommended using simplified abbreviations (or codes) for reporting burn test results.

Response. The existing Standard does not provide codes to report test results. However, the FTC developed test result codes many years ago for both plain surface and raised fiber surface textile fabrics. These codes are found in the CPSC's laboratory test manual, and the CPSC laboratory staff has used them to record test results for a number of years. Uniform result codes will facilitate reporting accuracy, understanding of flammability performance and resolution of test result differences among laboratories. For these reasons the proposal provides test result codes.

E. Preliminary Regulatory Analysis

Introduction

The Commission has preliminarily determined to issue a rule revising and reorganizing the Standard for the Flammability of Clothing Textiles. Section 4(i) of the FFA requires that the Commission prepare a preliminary regulatory analysis for a proposed regulation under the FFA and that it be published with the proposed rule. 15 U.S.C. 1193(i). The following discussion, extracted from the staff's memorandum titled "Preliminary Regulatory Analysis: Amendment to Clothing Textile Standard," addresses this requirement.

Potential Benefits and Costs

Any benefits of the proposed revision would accrue through a reduction in injury and death associated with clothing ignition. However, the proposed amendment simply codifies existing industry practices, and is not intended to change the types and classes of textiles (or garments) available for consumer use. Consequently, we do not anticipate any change in injuries or deaths due to this revision. Therefore, this amendment would not result in any additional expected benefits associated with the Standard.

Similarly, the proposal is not expected to increase costs to manufacturers. Any increased costs that would have been incurred were already borne by manufacturers when they voluntarily initiated the test modifications which would be called for under the revision. No additional testing or recordkeeping requirements are contemplated as a result of the proposed amendment. Again, this amendment simply codifies current industry practices. If anything, this proposed revision may reduce the industry burden since it modifies requirements that are outdated and/or impossible to comply with.

Alternatives

One alternative would be for the Commission to choose to use the ASTM standard as a template for the proposed amendment. The ASTM standard is a recent update (2001) of the FFA regulations promulgated in 1953. This option would harmonize the voluntary standard with the mandatory FFA standard. However, the more extensive definitional language of the proposed revised standard is more complete and more easily understood than that of the ASTM standard, which follows a different organizational format.

Another option may be to use the test procedures outlined in the ASTM

standard, combined with the definitional content of the proposal. While each of the options is likely to result in equivalence with the current Standard, the Commission believes that the detail of its proposed language could better address the potential for confusion and mis-classification of clothing textiles by the industry.

F. Regulatory Flexibility Certification

The Regulatory Flexibility Act ("RFA") generally requires that agencies review proposed rules for their potential economic impact on small entities, including small businesses. Section 603 of the RFA calls for agencies to prepare and make available for public comment an initial regulatory flexibility analysis describing the impact of the proposed rule on small entities and identifying impact-reducing alternatives. 5 U.S.C. 603. However, section 605 states that this requirement does not apply if the head of the agency certifies that the rule will not have a significant economic impact on a substantial number of small entities, and the agency provides an explanation for that conclusion.

This rulemaking will have little or no effect on small businesses in the textile and apparel industries because, as discussed above, the proposal is largely a technical one that updates the FFA Standard to current industry practices. Therefore, the Commission concludes that the proposed amendment will not have a significant economic impact on a substantial number of small entities.

G. Environmental Considerations

Generally, CPSC rules are considered to "have little or no potential for affecting the human environment," and environmental assessments are not usually prepared for these rules (see 16 CFR 1021.5 (c)(1)). Because the proposal continues current industry practices, it is not expected to alter production processes or affect the amounts of materials used in manufacturing, packaging or labeling. Therefore, the Commission does not expect the proposal to have any negative environmental impact.

H. Executive Orders

Executive Order 12988 (February 5, 1996), requires agencies to state in clear language the preemptive effect, if any, to be given to a new regulation. The clothing standard amendment, if issued on a final basis, would modify a flammability standard issued under the FFA. With certain exceptions which are not applicable in this instance, no state or political subdivision of a state may enact or continue in effect "a flammability standard or other

regulation" applicable to the same fabric or product covered by an FFA standard if the state or local flammability standard or other regulations is "designed to protect against the same risk of the occurrence fire" unless the state or local flammability standard or regulation "is identical" to the FFA standard. See section 16 of the FFA (15 U.S.C. 1203).

I. Effective Date

Section 4(b) of the FFA (15 U.S.C. 1193(b)) provides that an amendment of a flammability standard shall become effective one year from the date it is promulgated, unless the Commission finds for good cause that an earlier or later effective date is in the public interest, and publishes that finding. Section 4(b) also requires that an amendment of a flammability standard shall exempt products "in inventory or with the trade" on the date the amendment becomes effective, unless the Commission limits or withdraws that exemption because those products are so highly flammable that they are dangerous for use by consumers.

The Commission believes that a shorter effective date is in the public interest. As discussed above, the proposed revisions reflect practices that industry and laboratories are currently following. Thus, the impact of the proposed changes should be minimal. Moreover, it should be helpful to the public if the clarifications provided in the proposed revision are effective sooner than one year. Therefore, the Commission proposes that the revisions to the Standard would become effective 180 days after publication of a final amendment and that products "in inventory or with the trade" would be exempt from the revised standard.

J. Proposed Findings

Section 1193(a) and (j)(2) of the FFA require the Commission to make certain findings when it issues or amends a flammability standard. The Commission must find that the standard or amendment: (1) Is needed to adequately protect the public against the risk of the occurrence of fire leading to death, injury or significant property damage; (2) is reasonable, technologically practicable, and appropriate; (3) is limited to fabrics, related materials or products which present unreasonable risks; and (4) is stated in objective terms. 15 U.S.C. 1193(b). In addition, the Commission must find that: (1) If an applicable voluntary standard has been adopted and implemented, that compliance with the voluntary standard is not likely to adequately reduce the risk of injury, or compliance with the

voluntary standard is not likely to be substantial; (2) that benefits expected from the regulation bear a reasonable relationship to its costs; and (3) that the regulation imposes the least burdensome alternative that would adequately reduce the risk of injury. These findings are discussed below.

The amendment to the Standard is needed to adequately protect the public against unreasonable risk of the occurrence of fire. The Standard dates from 1953. In the past fifty years changes-in-technology and consumer practices have made some parts of the Standard obsolete. Through the years, some have found the Standard's terminology and organization confusing and difficult to follow. The proposed amendment will better reflect the modern practices followed by industry and consumers, and modifications in the language and organization of the standard will enhance its clarity.

The amendment to the Standard is reasonable, technologically practicable, and appropriate. The proposed amendment essentially establishes in the Standard the practices currently followed by industry and testing laboratories. These changes should enhance the Standard's reasonableness, practicability, and appropriateness.

The amendment to the Standard is limited to fabrics, related materials, and products that present an unreasonable risk. The proposed amendment continues to apply to the same textiles as the existing Standard.

Voluntary standards. The proposed Standard is similar to ASTM D1230 Standard Test Method for Flammability of Apparel Textiles in methods of testing but significantly different in refurbishing procedures, terminology and criteria. The Commission believes that the proposed amendment will provide better clarity to industry and testing laboratories and therefore is likely to better address the risk of injury.

Relationship of benefits to costs. Because the proposed amendment reflects current practices, both anticipated costs and benefits are likely to be small.

Least burdensome requirement. The proposed amendment makes no substantive changes to the Standard, but only provides modifications that are necessary to update and clarify the Standard.

K. Conclusion

For the reasons discussed above, the Commission preliminarily finds that amending the clothing textile flammability standard is needed to adequately protect the public against the unreasonable risk of the occurrence of

fire leading to death, injury, and significant property damage. The Commission also preliminarily finds that the amendment to the Standard is reasonable, technologically practicable, and appropriate. The Commission further finds that the amendment is limited to the fabrics, related materials and products which present such unreasonable risks.

List of Subjects in 16 CFR Part 1610

Clothing, Consumer protection, Flammable materials, Reporting and recordkeeping requirements, Textiles, Warranties.

Therefore, the Commission proposes to amend Title 16 of the Code of Federal Regulations by revising part 1610 to read as follows:

PART 1610—STANDARD FOR THE FLAMMABILITY OF CLOTHING TEXTILES

Subpart A—The Standard

- Sec.
- 1610.1 Purpose, scope and applicability.
 - 1610.2 Definitions.
 - 1610.3 Summary of test method.
 - 1610.4 Requirements for classifying textiles.
 - 1610.5 Test apparatus and materials.
 - 1610.6 Test procedure.
 - 1610.7 Test sequence and classification criteria.
 - 1610.8 Reporting results.

Subpart B—Rules and Regulations

- 1610.31 Definitions.
- 1610.32 General requirements.
- 1610.33 Test procedures for textile fabrics and film.
- 1610.34 Only uncovered or exposed parts of wearing apparel to be tested.
- 1610.35 Procedures for testing special types of textile fabrics under the standard.
- 1610.36 Application of Act to particular types of products.
- 1610.37 Reasonable and representative tests to support guaranties.
- 1610.38 Maintenance of records by those furnishing guaranties.
- 1610.39 Shipments under section 11(c) of the Act.
- 1610.40 Use of alternative apparatus, procedures, or criteria for tests for guaranty purposes.

Subpart C—Interpretations and Policies

- 1610.61 Reasonable and representative testing to assure compliance with the standard for the clothing textiles.
- Figure 1 to Part 1610—Sketch of Flammability Apparatus
- Figure 2 to Part 1610—Flammability Apparatus Views
- Figure 3 to Part 1610—Specimen Holder Supported in Specimen Rack
- Figure 4 to Part 1610—Igniter
- Figure 5 to Part 1610—Brushing Device
- Figure 6 to Part 1610—Brush
- Figure 7 to Part 1610—Template

Authority: 15 U.S.C. 1191–1204.

Subpart A—The Standard

§ 1610.1 Purpose, scope and applicability.

(a) *Purpose.* The purpose of this standard is to reduce danger of injury and loss of life by providing, on a national basis, standard methods of testing and rating the flammability of textiles and textile products for clothing use, thereby prohibiting the use of any dangerously flammable clothing textiles.

(b) *Scope.* The Standard provides methods of testing the flammability of clothing and textiles intended to be used for clothing, establishes three classes of flammability, sets forth the requirements which textiles shall meet to be classified, and warns against the use of those textiles which have burning characteristics unsuitable for clothing. Hereafter, "clothing and textiles intended to be used for clothing" shall be referred to as "textiles."

(c) *Specific exceptions.* This standard shall not apply to: (1) Hats, provided they do not constitute or form part of a covering for the neck, face, or shoulders when worn by individuals;

(2) Gloves, provided they are not more than 14 inches in length and are not affixed to or do not form an integral part of another garment;

(3) Footwear, provided it does not consist of hosiery in whole or part and is not affixed to or does not form an integral part of another garment;

(4) Interlining fabrics, when intended or sold for use as a layer between an outer shell and an inner lining in wearing apparel.

(d) *Specific exemptions.* Experience gained from years of testing in accordance with the Standard demonstrates that certain fabrics consistently yield acceptable results when tested in accordance with the Standard. Therefore, persons and firms issuing an initial guaranty of any of the following types of fabrics, or of products made entirely from one or more of these fabrics, are exempt from any requirement for testing to support guaranties of those fabrics:

(1) Plain surface fabrics, regardless of fiber content, weighing 2.6 ounces per square yard or more; and

(2) All fabrics, both plain surface and raised-fiber surface textiles, regardless of weight, made entirely from any of the following fibers or entirely from combination of the following fibers: acrylic, modacrylic, nylon, olefin, polyester, wool.

(e) *Applicability.* The requirements of this part 1610 shall apply to textile fabric or related material in a form or state ready for use in an article of

wearing apparel, including garments and costumes finished for consumer use.

§ 1610.2 Definitions.

In addition to the definitions given in Section 2 of the Flammable Fabrics Act as amended (15 U.S.C. 1191), the following definitions apply for this part 1610.

(a) *Base burn* (also known as base fabric ignition or fusing) means the point at which the flame burns the ground (base) fabric of a raised surface textile fabric and provides a self-sustaining flame. Base burns, used to establish a Class 3 fabric, are those burns resulting from surface flash that occur on specimens in places other than the point of impingement when the warp and fill yarns of a raised surface textile fabric undergo combustion. Base burns can be identified by an opacity change, scorching on the reverse side of the fabric, or when a physical hole is evident.

(b) *Burn time* means the time elapsed from ignition until the stop thread is severed as measured by the timing mechanism of the test apparatus.

(c) *Dry cleaning* means the cleaning of samples in a commercial dry cleaning machine under the conditions described in § 1610.6.

(d) *Film* means any non-rigid, unsupported plastic, rubber or other synthetic or natural film or sheeting, subject to the Act, or any combination thereof, including transparent, and opaque material, whether plain, embossed, molded, or otherwise surface treated, which is in a form or state ready for use in wearing apparel, and shall include film or sheeting of any thickness.

(e) *Flammability* means those characteristics of a material that pertain to its relative ease of ignition and relative ability to sustain combustion.

(f) *Flame application time* means the 1 second during which the ignition flame is applied to the test specimen.

(g) *Ignition* means that there is a self-sustaining flame on the specimen after the test flame is removed.

(h) *Interlining* means any textile which is intended for incorporation into an article of wearing apparel as a layer between an outer shell and an inner lining.

(i) *Laundrying* means washing with an aqueous detergent solution and includes rinsing, extraction and tumble drying as described in § 1610.6.

(j) *Long dimension* means the 150 mm (6 in) length of test specimen.

(k) *Plain surface textile fabric* means any textile fabric which does not have an intentionally raised fiber or yarn

surface such as a pile, nap, or tuft, but shall include those fabrics that have fancy woven, knitted or flock-printed surfaces.

(l) *Raised surface textile fabric* means any textile fabric with an intentionally raised fiber or yarn surface, such as a pile, including flocked pile, nap, or tufting.

(m) *Refurbishing* means dry cleaning and laundrying in accordance with § 1610.6.

(n) *Sample* means a portion of a lot of material which is taken for testing or for record keeping purposes.

(o) *Specimen* means a 50 mm by 150 mm (2 in by 6 in) section of sample.

(p) *Stop thread supply* means No. 50, white, mercerized, 100% cotton sewing thread.

(q) *Surface flash* means a rapid burning of the pile fibers and yarns on a raised fiber surface textile that may or may not result in base burning.

(r) *Textile fabric* means any coated or uncoated material subject to the Act, except film and fabrics having a nitro-cellulose fiber, finish, or coating, which is woven, knitted, felted or otherwise produced from any natural or manmade fiber, or substitute therefore, or combination thereof, of 50 mm (2 in) or more in width, and which is in a form or state ready for use in wearing apparel, including fabrics which have undergone further processing, such as dyeing and finishing, in garment form, for consumer use.

§ 1610.3 Summary of test method.

The Standard provides methods of testing the flammability of textiles for or intended to be used for apparel; establishes three classes of flammability; sets forth the requirements for classifying textiles; and prohibits the use of single or multi-layer textile fabrics that have burning characteristics that make them unsuitable for apparel. All textiles shall be tested before and after refurbishing according to § 1610.6. Each specimen cut from the textile shall be inserted in a frame, brushed if it has a raised fiber surface, and held in a special apparatus at an angle of 45°. A standardized flame shall be applied to the surface near the lower end of the specimen for 1 second, and the time required for the flame to proceed up the fabric a distance of 127 mm (5 in) shall be recorded. A notation shall be made as to whether the base of a raised-surface textile fabric ignites or fuses.

§ 1610.4 Requirements for classifying textiles.

(a) *Class 1, Normal Flammability.* Class 1 textiles exhibit normal flammability and are acceptable for use

in clothing. This class shall include textiles which meet the minimum requirements set forth in paragraph (a)(1) or paragraph (a)(2) of this section.

(1) *Plain surface textile fabric.* Such textiles in their original state and/or after being refurbished as described in § 1610.6(a) and § 1610.6(b), when tested as described in § 1610.6, shall be classified as Class 1, Normal Flammability, when the burn time is 3.5 seconds or more.

(2) *Raised surface textile fabric.* Such textiles in their original state and/or after being refurbished as described in § 1610.6(a) and § 1610.6(b), when tested as described in § 1610.6, shall be classified as Class 1, Normal Flammability, when the burn time is more than 7 seconds, or when they burn with a rapid surface flash (0 to 7 seconds), provided the intensity of the flame is so low as not to ignite or fuse the base fabric.

(b) *Class 2, Intermediate Flammability.* Class 2 fabrics, applicable only to raised fiber surface textiles, are considered to be of intermediate flammability, but may be used for clothing. This class shall include textiles which meet the minimum requirements set forth in paragraph (b)(2) of this section.

(1) *Plain surface textile fabric.* Class 2 is not applicable to plain surface textile fabrics.

(2) *Raised surface textile fabric.* Such textiles in their original state and/or after being refurbished as described in § 1610.6(a) and § 1610.6(b), when tested as described in § 1610.6, shall be classified as Class 2, Intermediate Flammability, when the burn time is from 4 through 7 seconds, both inclusive, and the base fabric ignites or fuses.

(c) *Class 3, Rapid and Intense Burning.* Class 3 textiles exhibit rapid and intense burning, are dangerously flammable and shall not be used for clothing. This class shall include textiles which have burning characteristics as described in paragraphs (c)(1) and (c)(2) of this section. Such textiles are considered dangerously flammable because of their rapid and intense burning.

(1) *Plain surface textile fabric.* Such textiles in their original state and/or after refurbishing as described in § 1610.6(a) and § 1610.6(b), when tested as described in § 1610.6, shall be classified as Class 3 Rapid and Intense Burning when the time of flame spread is less than 3.5 seconds.

(2) *Raised surface textile fabric.* Such textiles in their original state and/or after refurbishing as described in § 1610.6(a) and § 1610.6(b), when tested

as described in § 1610.6, shall be classified as Class 3 Rapid and Intense

Burning when the time of flame spread is less than 4 seconds and the intensity

of flame is such as to ignite or fuse the base fabric.

TABLE 1 TO § 1610.4.—SUMMARY OF TEST CRITERIA FOR SPECIMEN CLASSIFICATION

[See also § 1610.7]

Class	Plain surface textile fabric	Raised surface textile fabric
1	Burn time is 3.5 seconds or more. ACCEPTABLE (3.5 sec is a pass).	(1) Burn time is greater than 7.0 seconds or (2) Burn time is 0–7 seconds with no base burns. Exhibits rapid surface flash only. ACCEPTABLE
2	Class 2 is not applicable to plain surface textile fabrics	Burn time is 4–7 seconds (inclusive) with base burn. ACCEPTABLE
3	Burn time is less than 3.5 seconds. NOT ACCEPTABLE	Burn time is less than 4.0 seconds with base burn. NOT ACCEPTABLE.

§ 1610.5 Test apparatus and materials.

(a) *Flammability apparatus.* The flammability test apparatus consists of a draft-proof ventilated chamber enclosing a standardized ignition mechanism, sample rack, and automatic timing mechanism. The flammability apparatus shall meet the minimum requirements for testing as follows.

(1) *Test chamber.*—(i) *Test chamber structure.* The test chamber shall be a metal, draft-proof ventilated chamber. The test chamber shall have inside dimensions of 35.3 cm high by 36.8 cm wide by 21.6 cm deep (14 in by 14.5 in by 8.5 in). There shall be eleven 12.7 mm diameter (0.5 in) holes equidistant along the rear of the top closure. The front of the chamber shall be a close fitting door with an insert made of clear material (i.e., glass, plexiglass) to permit observation of the entire test. A ventilating strip is provided at the base of the door in the front of the apparatus. The test chamber to be used in this test method is illustrated in Figures 1 through 3 of this part.

(ii) *Specimen rack.* The specimen rack provides support for the specimen holder (described in paragraph (a)(1)(iii) of this section) in which the specimen is mounted for testing. The angle of inclination shall be 45°. Two guide pins projecting downward from the center of the base of the rack travel in slots provided in the floor of the chamber so that adjustment can be made for the thickness of the specimen in relation to the test flame. A stop shall be provided in the base of the chamber to assist in adjusting the position of the rack. The specimen rack shall be constructed so that it supports the specimen holder in a way that does not obstruct air flow around the bottom edge of the fabric specimen; and the fabric specimen is properly aligned with the igniter tip during flame impingement. The specimen rack to be used in this test method is illustrated in Figures 1 and 2 of this part. Movable rack: Refer to the

manufacturers' instruction in relation to the adjustment procedure to move the rack into the appropriate position for the indicator finger alignment.

(iii) *Specimen holder.* The specimen holder supports and holds the fabric specimen. The specimen holder shall consist of two 2 mm (0.06 in) thick U-shaped matched metal plates. The plates are slotted and loosely pinned for alignment. The specimen shall be firmly sandwiched in between the metal plates with clamps mounted along the sides. The two plates of the holder shall cover all but 3.8 cm (1.5 in) of the width of the specimen for its full length. See Figure 3 of this part. The specimen holder shall be supported in the draft-proof chamber on the rack at an angle of 45°.

(iv) *Indicator finger.* The position of the specimen rack (described in paragraph (a)(1)(ii) of this section) shall be adjusted, so the tip of the indicator finger just touches the surface of the specimen. The indicator finger is necessary to ensure that the tip of the test flame will impinge on the specimen during testing. The indicator finger to be used in this test method is illustrated in Figures 1 and 2 of this part.

(v) *Ignition mechanism.* The ignition mechanism shall consist of a motor driven butane gas jet formed around a 26-gauge hypodermic needle and creates the test flame. The test flame shall be protected by a shield. The test flame is adjusted to 16 mm (0.625 in) and applied to the specimen for 1 second. A trigger device is located in the front of the apparatus, the pulling or pushing of which activates the test flame impingement and timing device. Electro-mechanical devices (i.e., servomotors, solenoids, micro-switches, and electronic circuits, in addition to miscellaneous custom made cams and rods, shock absorbing linkages, and various other mechanical components) can be used to control and apply the

flame impingement. See Figure 7 of this part.

(vi) *Draft ventilator strip.* A draft ventilator strip shall be placed across the front opening, sealing the space between the sliding door when in lowered position and the base on which the grid rack is attached. (See Figure 1 of this part.)

(vii) *Stop weight.* The weight, attached by means of a clip to the stop thread, in dropping actuates the stop motion for the timing mechanism. The weight shall be at least 30g (1.16 oz).

(viii) *Door.* The door shall be a clear (i.e., glass or plexiglass) door, close fitting and allows for viewing of the entire test.

(ix) *Hood.* The hood or other suitable enclosure shall provide a draft-free environment surrounding the test chamber. The hood or other suitable enclosure shall have a fan or other means for exhausting smoke and/or fumes produced by testing.

(2) *Stop thread and thread guides.*—(i) *Stop thread.* The stop thread shall be stretched from the spool through suitable thread guides provided on the specimen holder and chamber walls.

(ii) *Stop thread supply.* This supply, consisting of a spool of No. 50, white, mercerized, 100% cotton sewing thread, shall be fastened to the side of the chamber and can be withdrawn by releasing the thumbscrew holding it in position.

(iii) *Thread guides.* The thread guides permit the lacing of the stop thread in the proper position exactly 127 mm (5 in) from the point where the center of the ignition flame impinges on the test specimen. The stop thread shall be 9.5 mm (0.37 in) above and parallel to the lower surface of the top plate of the specimen holder. This condition can be achieved easily and reproducibly with the use of a thread guide popularly referred to as a "sky hook" suspended down from the top panel along with two L-shaped thread guides attached to the

upper end of the top plate of the specimen holder. Two other thread guides can be installed on the rear panel to draw the thread away from directly over the test flame. The essential condition, however, is the uniform height of 9.5 mm (0.37 in) for the stop thread and not the number, placement or design of the thread guides.

(iv) *Stop weight thread guide.* This thread guide shall be used to guide the stop thread when attaching the stop weight.

(3) *Supply for test flame.* (i) The fuel supply shall be a cylinder of chemically pure (c. p.) butane.

(ii) The fuel-tank control valve shall consist of a sensitive control device for regulating the fuel supply at the tank.

(iii) The flow control device, such as a manometer or flow meter, shall be sufficient to maintain a consistent flame length of $\frac{5}{8}$ in.

(4) *Timing device.* The timing device consists of a timer, driving mechanism and weight. The timer, by means of special attachments, is actuated to start by connection with the gas jet. A trigger device (described in paragraph (a)(1)(v) of this section) activates the flame impingement, causing the driving mechanism to move the gas jet to its most forward position and automatically starts the timer at the moment of flame impact with the specimen. The falling weight, when caused to move by severance of the stop thread, stops the timer. Time shall be read directly and recorded as a burn time. Read burn time to 0.1 second. An electronic or mechanical timer can be used to record the burn time, and electro-mechanical devices (i.e., servomotors, solenoids, micro-switches, and electronic circuits, in addition to miscellaneous custom made cams and rods, shock absorbing linkages, and various other mechanical components) can be used to control and apply the flame impingement.

(b) *Specimen preparation equipment and materials—(1) Laboratory drying oven.* This shall be a forced circulation drying oven capable of maintaining $105 \pm 3^\circ\text{C}$ ($221 \pm 5^\circ\text{F}$) for 30 ± 2 minutes to dry the specimens while mounted in the specimen holders.

(2) *Desiccator.* This shall be an airtight and moisture tight chamber capable of holding the specimens horizontally without contacting each other during the cooling period following drying, and shall contain silica gel desiccant.

(3) *Desiccant.* Anhydrous silica gel shall be used as the desiccant.

(4) *Automatic washing machine.* The automatic washing machine shall be as described in § 1610.6(b)(1)(ii).

(5) *Automatic tumble dryer.* The automatic tumble dryer shall be as described in § 1610.6(b)(1)(ii).

(6) *Commercial dry cleaning machine.* The commercial dry cleaning machine shall be capable of providing a complete automatic dry-to-dry cycle using perchloroethylene solvent and a cationic drycleaning detergent as specified in § 1610.6(b)(1)(i).

(7) *Dry cleaning solvent.* The solvent shall be perchloroethylene, commercial grade.

(8) *Dry cleaning detergent.* The dry cleaning detergent shall be cationic class.

(9) *Laundering detergent.* The laundering detergent shall be as specified in § 1610.6(b)(1)(i).

(10) *Brushing device.* The brushing device shall consist of a base board over which a small carriage is drawn. See Figure 4 of this part. This carriage runs on parallel tracks attached to the edges of the upper surface of the base board. The brush is hinged with pin hinges at the rear edge of the base board and rests on the carriage vertically with a pressure of 150 gf (0.33 lbf). The brush shall consist of two rows of stiff nylon bristles mounted with the tufts in a staggered position. The bristles are 0.41 mm (0.016 in) in diameter and 19 mm (0.75 in) in length. There are 20 bristles per tuft and 4 tufts per inch. See Figure 6 of this part. A clamp is attached to the forward edge of the movable carriage to permit holding the specimen on the carriage during the brushing operation. The purpose of the metal plate or "template" on the carriage of the brushing device is to support the specimen during the brushing operation. The template shall be 3.2 mm (0.13 in) thick. See Figure 5 of this part.

§ 1610.6 Test procedure.

The test procedure is divided into two steps. Step 1 is testing in the "as received" or original state; Step 2 is testing after the fabric has been refurbished according to paragraph (b)(1) of this section.

(a) *Step 1—Testing in the "as received" or original state.* (1) Tests shall be conducted on the fabric in a form or state ready for use in wearing apparel. Determine whether the fabric to be tested is a plain surface textile fabric or a raised surface textile fabric as defined in § 1610.2 (k) and (l). There are some fabrics that require extra attention when preparing test specimens because of their particular construction characteristics. Examples of these fabrics are provided in paragraphs (a)(1)(i) through (vi) of this section along with guidelines for preparing specimens

from these fabrics. This information is not intended to be all-inclusive.

(i) *Flocked fabrics.* Fabrics that are flocked overall are treated as raised surface textile fabrics as defined in § 1610.2(l). Flock printed fabrics (usually in a pattern and not covering the entire surface) shall be treated as plain surface textile fabrics as defined in § 1610.2(k).

(ii) *Cut velvet fabrics.* Cut velvet fabrics with a patterned construction shall be considered a raised surface textile fabric as defined in § 1610.2(l).

(iii) *Metallic thread fabrics.* Metallic thread fabrics shall be considered plain surface textile fabrics provided the base fabric is smooth. The specimens shall be cut so that the metallic thread is parallel to the long dimension of the specimen and arranged so the test flame impinges on a metallic thread.

(iv) *Embroidery.* Embroidery on netting material shall be tested with two sets of preliminary specimens to determine the most flammable area (which offers the greatest amount of netting or embroidery in the 150 mm (6 in.) direction). One set of netting only shall be tested and the other set shall consist mainly of embroidery with the specimens cut so that the test flame impinges on the embroidered area. Test the most flammable area according to the plain surface textile fabric requirements. The full test shall be completed on a sample cut from the area that has the fastest burn rate.

(v) *Burn-out patterns.* Flat woven constructions with burn-out patterns shall be considered plain surface textile fabrics as defined in § 1610.2(k).

(vi) *Narrow fabrics and loose fibrous materials.* Narrow fabrics and loose fibrous materials manufactured less than 50 mm (2 in) in width in either direction shall not be tested. If a 50 mm by 150 mm (2 in by 6 in) specimen cannot be cut due to the nature of the item, i.e. hula skirts, leis, fringe, loose feathers, wigs, hairpieces, etc., do not conduct a test.

(2) *Plain surface textile fabrics—(i) Preliminary trials.* Conduct preliminary trials to determine the quickest burning direction. The specimen size shall be 50 mm by 150 mm (2 in by 6 in). Cut one specimen from each direction of the fabric. Identify the fabric direction being careful not to make any identifying marks in the exposed area to be tested. Preliminary specimens shall be mounted and conditioned as described in paragraphs (a)(2)(ii) through (iv) of this section and then tested following the procedure in paragraph (c) of this section to determine if there is a difference in the burning characteristics

with respect to the direction of the fabric.

(ii) *Identify and cut test specimens.* Cut the required number of test specimens to be tested (refer to § 1610.7(b)(1)). Each specimen shall be 50 mm by 150 mm (2 in by 6 in), with the long dimension in the direction in which burning is most rapid as established in the preliminary trials. Be careful not to make any identifying marks in the exposed area to be tested.

(iii) *Mount specimens.* Specimens shall be placed in the holders, with the side to be burned face up. Even though plain surface textile fabrics are not brushed, all specimens shall be mounted in a specimen holder placed on the carriage that rides on the brushing device to ensure proper position in the holder. A specimen shall be placed between the two metal plates of a specimen holder and clamped. Each specimen shall be mounted and clamped prior to conditioning and testing.

(iv) *Condition specimens.* All specimens mounted in the holders shall then be placed in a horizontal position on an open metal shelf in the oven to permit free circulation of air around them. The specimens shall be dried in the oven for 30 ± 2 minutes at $105^\circ \pm 3^\circ\text{C}$ ($221^\circ \pm 5^\circ\text{F}$), removed from the oven and placed over a bed of anhydrous silica gel desiccant in a desiccator until cool, but not less than 15 minutes.

(v) *Flammability test.* Follow the test procedure in paragraph (c) of this section and also follow the test sequence in § 1610.7(b)(1).

(3) *Raised surface textile fabrics.*—(i) *Preliminary trials.* The most flammable surface of the fabric shall be tested. Conduct preliminary trials and/or visual examination to determine the quickest burning area. The specimen size shall be 50 mm by 150 mm (2 in by 6 in). For raised surface textile fabrics, the direction of the lay of the surface fibers shall be parallel with the long dimension of the specimen. Specimens shall be taken from that part of the raised fiber surface that appears to have the fastest burn time. For those fabrics where it may be difficult to visually determine the correct direction of the lay of the raised surface fibers, preliminary tests can be done to determine the direction of the fastest burn time. For textiles with varying depths of pile, tufting, etc., the preliminary test specimens are taken from each depth of pile area to determine which exhibits the quickest rate of burning. A sufficient number of preliminary specimens shall be tested to provide adequate assurance that the

raised surface textile fabric will be tested in the quickest burning area. Preliminary specimens shall be mounted and conditioned as described below and tested following the procedure in paragraph (c) of this section.

(ii) *Identify and cut test specimens.* Cut the required number of specimens (refer to § 1610.7(b)(3)) to be tested. Each specimen shall be 50 mm by 150 mm (2 in by 6 in), with the specimen taken from the direction in which burning is most rapid as established in the preliminary trials and/or visual examination. Be careful not to make any identifying marks in the exposed area to be tested.

(iii) *Mount specimens.* Prior to mounting the specimen, run a fingernail along the 150 mm (6 in) edge of the fabric not more than 6.4 mm (0.25 in) in from the side to determine the lay of the surface fibers. All specimens shall be mounted in a specimen holder placed on the carriage that rides on the brushing device. The specimens shall be mounted with the side to be burned face up and positioned so the lay of the surface fibers is going away from the closed end of the specimen holder. The specimen must be positioned in this manner so that the brushing procedure described in paragraph (a)(3)(iv) of this section will raise the surface fibers, i.e., the specimen is brushed against the direction of the lay of the surface fibers. The specimen shall be placed between the two metal plates of the specimen holder and clamped.

(iv) *Brush specimens.* After mounting in the specimen holder (and with the holder still on the carriage that rides on the brushing device) each specimen shall be brushed one time. The carriage is pushed to the rear of the brushing device, and the brush lowered to the face of the specimen. The carriage shall be drawn forward by hand once against the lay of the surface fibers at a uniform rate. Brushing of a specimen shall be performed with the specimen mounted in a specimen holder. The purpose of the metal plate or "template" on the carriage of the brushing device is to support the specimen during the brushing operation.

(v) *Condition specimens.* All specimens (mounted and brushed) in the holders shall be then placed in a horizontal position on an open metal shelf in the oven to permit free circulation of air around them. The specimens shall be dried in the oven for 30 ± 2 minutes at $105^\circ \pm 3^\circ\text{C}$ ($221^\circ \pm 5^\circ\text{F}$) removed from the oven and placed over a bed of anhydrous silica gel desiccant in a desiccator until cool, but not less than 15 minutes.

(vi) *Conduct flammability test.* Follow the procedure in paragraph (c) of this section and follow the test sequence in § 1610.7(b)(3).

(b) *Step 2—Refurbishing and testing after refurbishing.* (1) The refurbishing procedures are the same for both plain surface textile fabrics and raised fiber surface textile fabrics. Those samples that result in a Class 3, Rapid and Intense Burning after Step 1 testing in the "as received" or original state shall not be refurbished and do not undergo Step 2.

(i) *Dry cleaning procedure.* (A) All samples shall be dry cleaned before they undergo the laundering procedure. Samples shall be dry cleaned in a commercial dry cleaning machine, using the following prescribed conditions:
Solvent: Perchloroethylene, commercial grade
Detergent class: Cationic
Cleaning time: 10–15 minutes
Extraction time: 3 minutes
Drying Temperature: $60 - 66^\circ\text{C}$ ($140 - 150^\circ\text{F}$)
Drying Time: 18–20 minutes
Cool Down/Deodorization time: 5 minutes

(B) Samples shall be dry cleaned in a load that is 80% of the machine's capacity. If necessary, ballast consisting of clean textile pieces or garments, white or light in color and consisting of approximately 80% wool and 20% polyester, shall be used.

(ii) *Laundering procedure.* The sample, after being subjected to the dry cleaning procedure, shall be washed and dried one time in accordance with sections 8.2.2, 8.2.3 and 8.3.1(A) of AATCC Test Method 124–2001 "Appearance of Fabrics after Repeated Home Laundering." Washing shall be performed in accordance with sections 8.2.2 and 8.2.3 of AATCC Test Method 124–2001 using wash water temperature (V) ($149^\circ \pm 5^\circ\text{F}$; $60^\circ \pm 3^\circ\text{C}$) specified in Table II of that method, and the water level, agitator speed, washing time, spin speed and final spin cycle specified for "Normal/Cotton Sturdy" in Table III. A maximum wash load shall be 8 pounds (3.63 kg) and may consist of any combination of test samples and dummy pieces. Drying shall be performed in accordance with section 8.3.1(A) of that test method, Tumble Dry, using the exhaust temperature ($150^\circ \pm 10^\circ\text{F}$; $66^\circ \pm 5^\circ\text{C}$) and cool down time of 10 minutes specified in the "Durable Press" conditions of Table IV.

(2) *Testing plain surface textile fabrics after refurbishing.* The test procedure is the same as for Step 1—Testing in the "as received" or original state described in paragraph (a)(1) of this section; also follow the test sequence § 1610.7(b)(2).

(3) *Testing raised fiber surface textile fabrics after refurbishing.* The test procedure is the same as for Step 1—Testing in the “as received” or original state as described in paragraph (a)(3) of this section; also follow the test sequence in § 1610.7(b)(4).

(c) *Procedure for testing flammability.*

(1) The test chamber shall be located under the hood (or other suitable enclosure) with the fan turned off. Open the control valve in the fuel supply. Allow approximately 5 minutes for the air to be drawn from the fuel line, ignite the gas and adjust the test flame to a length of 16 mm ($\frac{5}{8}$ in), measured from its tip to the opening in the gas nozzle.

(2) Remove one mounted specimen from the desiccator at a time and place it in a position on the rack in the chamber of the apparatus. Thick fabrics may require adjustment of the specimen rack so that the tip of the indicator finger just touches the surface of the specimen.

(3) Adjust the position of the specimen rack of the flammability test chamber so that the tip of the indicator finger just touches the face of the mounted specimen.

(4) String the stop thread through the guides in the upper plate of the specimen holder across the top of the specimen, and through any other thread guide(s) of the chamber. Hook the stop weight in place close to and just below the stop weight thread guide. Set the timing mechanism to zero. Close the door of the flammability test chamber.

(5) Begin the test within 45 seconds of the time the specimen was removed from the desiccator. Activate the trigger device to impinge the test flame. The trigger device controls the impingement of the test flame onto the specimen and starts the timing device. The timing is automatic and stops when the weight is released by the severing of the stop thread.

(6) At the end of each test, turn on the hood fan to exhaust any fumes or smoke produced during the test.

(7) Record the burn time (reading of the timer) for each specimen, along with visual observation using the test result codes given in § 1610.8. If there is no burn time, record the visual observation using the test result codes. Please note for raised fiber surface textile fabrics, specimens should be allowed to continue burning, even though a burn rate is measured, to determine if the base fabric will fuse.

(8) After exhausting all fumes and smoke produced during the test, turn off the fan before testing the next specimen.

§ 1610.7 Test sequence and classification criteria.

(a) *Preliminary and final classifications.* Preliminary classifications are assigned based on the test results both before and after refurbishing. The final classification shall be the preliminary classification before or after refurbishing, whichever is the more severe flammability classification.

(b) *Test sequence and classification criteria.* (1) Step 1, Plain Surface Textile Fabrics in the “as received” or original state.

(i) Conduct preliminary tests in accordance with § 1610.6(a)(2)(i) to determine the fastest burning direction of the fabric.

(ii) Prepare and test five specimens from the fastest burning direction. The burn times determine whether to assign the preliminary classification and proceed to § 1610.6(b) or to test five additional specimens.

(iii) Assign the preliminary classification of Class 1, Normal Flammability and proceed to § 1610.6(b) when:

(A) There are no burn times; or
(B) There is only one burn time and it is equal to or greater than 3.5 seconds; or

(C) The average burn time of two or more specimens is equal to or greater than 3.5 seconds.

(iv) Test five additional specimens when there is either only one burn time, and it is less than 3.5 seconds; or there is an average burn time of less than 3.5 seconds. Test these five additional specimens from the fastest burning direction as previously determined by the preliminary specimens. The burn times for the 10 specimens determine whether to:

(A) Stop testing and assign the final classification as Class 3, Rapid and Intense Burning only when there are two or more burn times with an average burn time of less than 3.5 seconds; or

(B) Assign the preliminary classification of Class 1, Normal Flammability and proceed to § 1610.6(b) when there are two or more burn times with an average burn time of 3.5 seconds or greater.

(v) If there is only one burn time out of the 10 test specimens, the test is inconclusive. The fabric cannot be classified.

(2) Step 2, Plain Surface Textile Fabrics after refurbishing in accordance with § 1610.6(b)(1).

(i) Conduct preliminary tests in accordance with § 1610.6(a)(2)(i) to determine the fastest burning direction of the fabric.

(ii) Prepare and test five specimens from the fastest burning direction. The burn times determine whether to stop testing and assign the preliminary classification or to test five additional specimens.

(iii) Stop testing and assign the preliminary classification of Class 1, Normal Flammability, when:

(A) There are no burn times; or
(B) There is only one burn time, and it is equal to or greater than 3.5 seconds; or

(C) There is an average burn time 3.5 seconds or greater.

(iv) Test five additional specimens when there is only one burn time, and it is less than 3.5 seconds; or there is an average burn time less than 3.5 seconds. Test five additional specimens from the fastest burning direction as previously determined by the preliminary specimens. The burn times for the 10 specimens determine the preliminary classification when:

(A) There are two or more burn times with an average burn time of 3.5 seconds or greater. The preliminary classification is Class 1, Normal Flammability; or

(B) There are two or more burn times with an average burn time of less than 3.5 seconds. The preliminary and final classification is Class 3, Rapid and Intense Burning; or

(v) If there is only one burn time out of the 10 specimens, the test results are inconclusive. The fabric cannot be classified.

(3) Step 1, Raised Surface Textile Fabric in the “as received” or original state.

(i) Determine the area to be most flammable per § 1610.6(a)(3)(i).

(ii) Prepare and test five specimens from the most flammable area. The burn times and visual observations determine whether to assign a preliminary classification and proceed to § 1610.6(b) or to test five additional specimens.

(iii) Assign the preliminary classification and proceed to § 1610.6(b) when:

(A) There are no burn times. The preliminary classification is Class 1, Normal Flammability; or

(B) There is only one burn time and it is less than 4 seconds without a base burn, or it is 4 seconds or greater with or without a base burn. The preliminary classification is Class 1, Normal Flammability; or

(C) There are no base burns regardless of the burn time(s). The preliminary classification is Class 1, Normal Flammability; or

(D) There are two or more burn times with an average burn time of 0–7 seconds with a surface flash only. The

preliminary classification is Class 1, Normal Flammability; or

(E) There are two or more burn times with an average burn time greater than 7 seconds with any number of base burns. The preliminary classification is Class 1, Normal Flammability; or

(F) There are two or more burn times with an average burn time of 4 through 7 seconds (both inclusive) with no more than one base burn. The preliminary classification is Class 1, Normal Flammability; or

(G) There are two or more burn times with an average burn time less than 4 seconds with no more than one base burn. The preliminary classification is Class 1, Normal Flammability; or

(H) There are two or more burn times with an average burn time of 4 through 7 seconds (both inclusive) with two or more base burns. The preliminary classification is Class 2, Intermediate Flammability.

(iv) Test five additional specimens when the tests of the initial five specimens result in either of the following: There is only one burn time and it is less than 4 seconds with a base burn; or the average of two or more burn times is less than 4 seconds with two or more base burns. Test these five additional specimens from the most flammable area. The burn times and visual observations for the 10 specimens will determine whether to:

(A) Stop testing and assign the final classification only if the average burn time for the 10 specimens is less than 4 seconds with three or more base burns. The final classification is Class 3, Rapid and Intense Burning; or

(B) Assign the preliminary classification and continue on to § 1610.6(b) when:

(1) The average burn time is less than 4 seconds with no more than two base burns. The preliminary classification is Class 1, Normal Flammability; or

(2) The average burn time is 4–7 seconds (both inclusive) with no more than 2 base burns. The preliminary classification is Class 1, Normal Flammability, or

(3) The average burn time is greater than 7 seconds. The preliminary classification is Class 1, Normal Flammability; or

(4) The average burn time is 4 through 7 seconds (both inclusive) with three or more base burns. The preliminary classification is Class 2, Intermediate Flammability, or

(v) If there is only one burn time out of the 10 specimens, the test is inconclusive. The fabric cannot be classified.

(4) Step 2, Raised Surface Textile Fabric After Refurbishing in accordance with § 1610.6(b).

(i) Determine the area to be most flammable in accordance with § 1610.6(a)(3)(i).

(ii) Prepare and test five specimens from the most flammable area. Burn times and visual observations determine whether to stop testing and determine the preliminary classification or to test five additional specimens.

(iii) Stop testing and assign the preliminary classification when:

(A) There are no burn times. The preliminary classification is Class 1, Normal Flammability; or

(B) There is only one burn time, and it is less than 4 seconds without a base burn; or it is 4 seconds or greater with or without a base burn. The preliminary classification is Class 1, Normal Flammability; or

(C) There are no base burns regardless of the burn time(s). The preliminary classification is Class 1, Normal Flammability; or

(D) There are two or more burn times with an average burn time of 0 to 7 seconds with a surface flash only. The preliminary classification is Class 1, Normal Flammability; or

(E) There are two or more burn times with an average burn time greater than 7 seconds with any number of base burns. The preliminary classification is Class 1, Normal Flammability; or

(F) There are two or more burn times with an average burn time of 4 through 7 seconds (both inclusive) with no more than one base burn. The preliminary classification is Class 1, Normal Flammability; or

(G) There are two or more burn times with an average burn time less than 4 seconds with no more than one base burn. The preliminary classification is Class 1, Normal Flammability; or

(H) There are two or more burn times with an average burn time of 4 through 7 seconds (both inclusive) with two or more base burns. The preliminary classification is Class 2, Intermediate Flammability.

(iv) Test five additional specimens when the tests of the initial five specimens result in either of the following: There is only one burn time, and it is less than 4 seconds with a base burn; or the average of two or more burn times is less than 4 seconds with two or more base burns.

(v) If required, test five additional specimens from the most flammable area. The burn times and visual observations for the 10 specimens determine the preliminary classification when:

(A) The average burn time is less than 4 seconds with no more than two base burns. The preliminary classification is Class 1, Normal Flammability; or

(B) The average burn time is less than 4 seconds with three or more base burns. The preliminary and final classification is Class 3, Rapid and Intense Burning; or

(C) The average burn time is greater than 7 seconds. The preliminary classification is Class 1, Normal flammability; or

(D) The average burn time is 4–7 seconds (both inclusive), with no more than two base burns. The preliminary classification is Class 1, Normal Flammability; or

(E) The average burn time is 4–7 seconds (both inclusive), with three or more base burns. The preliminary classification is Class 2, Intermediate Flammability; or

(vi) If there is only one burn time out of the 10 specimens, the test is inconclusive. The fabric cannot be classified.

§ 1610.8 Reporting results.

(a) The reported result shall be the classification before or after refurbishing, whichever is the more severe; and based on this result, the textile shall be placed in the proper final classification as described in § 1610.4.

(b) *Test result codes.* The following are the definitions for the test result codes, which shall be used for recording flammability results for each specimen that is burned.

(1) For Plain Surface Textile Fabrics:

DNI Did not ignite

IBE Ignited, but extinguished

*IBE Ignited, but extinguished, the asterisk

(* denotes a burn that goes under the stop thread without breaking the stop thread.

-- sec. Actual burn time measured and recorded by the timing device in 0.0 seconds.

(2) For Raised Surface Textile Fabrics:

SF uc Surface flash, under the stop thread, but does not break the stop thread.

SF pw Surface flash, part way. No time shown because the surface flash did not reach the stop thread.

SF poi Surface flash, at the point of impingement only (equivalent to "did not ignite" for plain surfaces).

-- sec. Actual burn time measured by the timing device in 0.0 seconds.

-- SF only Time in seconds, surface flash only. No damage to the base fabric.

-- SFBB Time in seconds, surface flash base burn. Base starts burning at points other than the point of impingement.

-- SFBB poi Time in seconds, surface flash base burn starting at the point of impingement.

... SFBB poi* Time in seconds, surface flash base burn possibly starting at the point of impingement. The asterisk is accompanied by the following statement: "Unable to make absolute determination as to source of base burns." This statement is added to the result of any specimen if there is a question as to origin of the base burn.

Subpart B—Rules and Regulations

§ 1610.31 Definitions.

In addition to the definitions provided in section 2 of the Flammable Fabrics Act as amended (15 U.S.C. 1191), and in § 1610.2 of the Standard, the following definitions apply for this subpart.

(a) *Act* means the "Flammable Fabrics Act" (approved June 30, 1953, Pub. Law 88, 83d Congress, 1st sess., 15 U.S.C. 1191; 67 Stat. 111) as amended, 68 Stat. 770, August 23, 1954.

(b) *Rule, rules, regulations, and rules and regulations*, mean the rules and regulations prescribed by the Commission pursuant to section 5(c) of the act.

(c) *United States* means, the several States, the District of Columbia, the Commonwealth of Puerto Rico and the Territories, and Possessions of the United States.

(d) *Marketing or handling* means the transactions referred to in section 3 of the Flammable Fabrics Act, as amended in 1967.

(e) *Test* means the application of the relevant test method prescribed in the procedures provided under section 4(a) of the Act (16 CFR part 1609).

(f) *Finish type* means a particular finish, but does not include such variables as changes in color, pattern, print, or design, or minor variations in the amount or type of ingredients in the finish formulation. Examples of finish types would be starch finishes, resin finishes or parchmented finishes.

(g) *Uncovered or exposed part* means that part of an article of wearing apparel that might during normal wear be open to flame or other means of ignition. The outer surface of an undergarment is considered to be an uncovered or exposed part of an article of wearing apparel, and thus subject to the Act. Other examples of exposed parts of an article of wearing apparel subject to the Act include, but are not limited to:

- (1) Linings, with exposed areas, such as full front zippered jackets;
- (2) Sweatshirts with exposed raised fiber surface inside and capable of being worn napped side out;
- (3) Unlined hoods;
- (4) Rolled cuffs.

§ 1610.32 General requirements.

No article of wearing apparel or fabric subject to the Act and regulations shall be marketed or handled if such article or fabric, when tested according to the procedures prescribed in section 4(a) of the Act (16 CFR part 1609), is so highly flammable as to be dangerous when worn by individuals.

§ 1610.33 Test procedures for textile fabrics and film.

(a)(1) All textile fabrics (except those with a nitro-cellulose fiber, finish or coating) intended or sold for use in wearing apparel, and all such fabrics contained in articles of wearing apparel, shall be subject to the requirements of the Act, and shall be deemed to be so highly flammable as to be dangerous when worn by individuals if such fabrics or any uncovered or exposed part of such articles of wearing apparel exhibits rapid and intense burning when tested under the conditions and in the manner prescribed in subpart A of this part 1610.

(2) Notwithstanding the provisions of paragraph (a)(1) of this section, coated fabrics, except those with a nitro-cellulose coating, may be tested under the procedures outlined in part 1611, Standard for the Flammability of Vinyl Plastic Film, and if such coated fabrics do not exhibit a rate of burning in excess of that specified in § 1611.3 they shall not be deemed to be so highly flammable as to be dangerous when worn by individuals.

(b) All film, and textile fabrics with a nitro-cellulose fiber, finish or coating intended or sold for use in wearing apparel, and all film and such textile fabrics referred to in this rule which are contained in articles of wearing apparel, shall be subject to the requirements of the Act, and shall be deemed to be so highly flammable as to be dangerous when worn by individuals if such film or such textile fabrics or any uncovered or exposed part of such articles of wearing apparel exhibit a rate of burning in excess of that specified in part 1611, Standard for the Flammability of Vinyl Plastic Film.

§ 1610.34 Only uncovered or exposed parts of wearing apparel to be tested.

(a) In determining whether an article of wearing apparel is so highly flammable as to be dangerous when worn by individuals, only the uncovered or exposed part of such article of wearing apparel shall be tested according to the applicable procedures set forth in § 1610.6.

(b) If the outer layer of plastic film or plastic-coated fabric of a multilayer fabric separates readily from the other

layers, the outer layer shall be tested under part 1611—Standard for the Flammability of Vinyl Plastic Film. If the outer layer adheres to all or a portion of one or more layers of the underlying fabric, the multi-layered fabric may be tested under either part 1610—Standard for the Flammability of Clothing Textiles or part 1611. However, if the conditioning procedures required by § 1610.6(a)(2)(iv) and § 1610.6(a)(3)(v) would damage or alter the physical characteristics of the film or coating, the uncovered or exposed layer shall be tested in accordance with part 1611.

(c) Plastic film or plastic-coated fabric used, or intended for use as the outer layer of disposable diapers is exempt from the requirements of the Standard, provided that a sample taken from a full thickness of the assembled article passes the test in the Standard (part 1610 or part 1611) otherwise applicable to the outer fabric or film when the flame is applied to the exposed or uncovered surface. See § 1610.36(f) and § 1611.36(f).

§ 1610.35 Procedures for testing special types of textile fabrics under the standard.

(a) *Fabric not customarily washed or dry cleaned.* (1) Except as provided in paragraph (a)(2) of this section, any textile fabric or article of wearing apparel which, in its normal and customary use as wearing apparel would not be dry cleaned or washed, need not be dry cleaned or washed as prescribed in § 1610.6(b) when tested under the Standard if such fabric or article of wearing apparel, when marketed or handled, is marked in a clear and legible manner with the statement: "Fabric may be dangerously flammable if dry cleaned or washed." An example of the type of fabric referred to in this paragraph is bridal illusion.

(2) Section 1610.3, which requires that all textiles shall be refurbished before testing, shall not apply to disposable fabrics and garments. Additionally, such disposable fabrics and garments shall not be subject to the labeling requirements set forth in paragraph (a)(1) of this section.

(b) A coated fabric need not, upon test under the procedures outlined in subpart A of part 1610, be dry cleaned as set forth in § 1610.6(b)(1)(i).

(c) In determining whether a textile fabric having a raised-fiber surface, which surface is to be used in the covered or unexposed parts of articles of wearing apparel, is so highly flammable as to be dangerous when worn by individuals, only the opposite surface or surface intended to be exposed need be tested under the applicable procedures

set forth in § 1610.6, providing an invoice or other paper covering the marketing or handling of such fabric is given which clearly designates that the raised-fiber surface is to be used only in the covered or unexposed parts of articles of wearing apparel.

§ 1610.36 Application of Act to particular types of products.

(a) *Interlinings.* Fabrics intended or sold for processing into interlinings or other covered or unexposed parts of articles of wearing apparel shall not be subject to the provisions of section 3 of the Act: *Provided*, that an invoice or other paper covering the marketing or handling of such fabrics is given which specifically designates their intended end use: *And provided further*, that with respect to fabrics which under the provisions of section 4 of the Act, as amended, are so highly flammable as to be dangerous when worn by individuals, any person marketing or handling such fabrics maintains records which show the acquisition, disposition and intended end use of such fabrics, and any person manufacturing articles of wearing apparel containing such fabrics maintains records which show the acquisition, and use and disposition of such fabrics. Any person who fails to maintain such records or to furnish such invoice or other paper shall be deemed to have engaged in the marketing or handling of such products for purposes subject to the requirements of the Act and such person and the products shall be subject to the provisions of sections 3, 6, 7, and 9 of the Act.

(b) *Hats, gloves, and footwear.* Fabrics intended or sold for use in those hats, gloves, and footwear which are excluded under the definition of articles of wearing apparel in section 2(d) of the Act shall not be subject to the provisions of section 3 of the Act: *Provided*, that an invoice or other paper covering the marketing or handling of such fabrics is given which specifically designates their intended use in such products: *And provided further*, that with respect to fabrics which under the provisions of section 4 of the Act, as amended, are so highly flammable as to be dangerous when worn by individuals, any person marketing or handling such fabrics maintains records which show the acquisition, disposition, and intended end use of such fabrics, and any person manufacturing hats, gloves, or footwear containing such fabrics maintains records which show the acquisition, end use and disposition of such fabrics. Any person who fails to maintain such records or to furnish such invoice or other paper shall be deemed to have

engaged in the marketing or handling of such products for purposes subject to the requirements of the Act and such person and the products shall be subject to the provisions of sections 3, 6, 7, and 9 of the Act.

(c) *Veils and hats.* (1) Ornamental millinery veils or veilings when used as a part of, in conjunction with, or as a hat, are not to be considered such a "covering for the neck, face, or shoulders" as would, under the first proviso of section 2(d) of the Act, cause the hat to be included within the definition of the term "article of wearing apparel" where such ornamental millinery veils or veilings do not extend more than nine (9) inches from the tip of the crown of the hat to which they are attached and do not extend more than two (2) inches beyond the edge of the brim of the hat.

(2) Where hats are composed entirely of ornamental millinery veils or veilings such hats will not be considered as subject to the Act if the veils or veilings from which they are manufactured were not more than nine (9) inches in width and do not extend more than nine (9) inches from the tip of the crown of the completed hat.

(d) *Handkerchiefs.* (1) Except as provided in paragraph (d)(2) of this section, handkerchiefs not exceeding a finished size of twenty-four (24) inches on any side or not exceeding five hundred seventy-six (576) square inches in area are not deemed "articles of wearing apparel" as that term is used in the Act.

(2) Handkerchiefs or other articles affixed to, incorporated in, or sold as a part of articles of wearing apparel as decoration, trimming, or for any other purpose, are considered an integral part of such articles of wearing apparel, and the articles of wearing apparel and all parts thereof are subject to the provisions of the Act. Handkerchiefs or other articles intended or sold to be affixed to, incorporated in or sold as a part of articles of wearing apparel as aforesaid constitute "fabric" as that term is defined in section 2(e) of the Act and are subject to the provisions of the Act, such handkerchiefs or other articles constitute textile fabrics as the term "textile fabric" is defined in § 1610.2(r).

(3) If, because of construction, design, color, type of fabric, or any other factor, a piece of cloth of a finished type or any other product of a finished type appears to be likely to be used as a covering for the head, neck, face, shoulders, or any part thereof, or otherwise appears likely to be used as an article of clothing, garment, such product is not a handkerchief and constitutes an article of wearing apparel as defined in and

subject to the provisions of the Act, irrespective of its size, or its description or designation as a handkerchief or any other term.

(e) *Raised-fiber surface wearing apparel.* Where an article of wearing apparel has a raised-fiber surface which is intended for use as a covered or unexposed part of the article of wearing apparel but the article of wearing apparel is, because of its design and construction, capable of being worn with the raised-fiber surface exposed, such raised-fiber surface shall be considered to be an uncovered or exposed part of the article of wearing apparel. Examples of the type of products referred to in this paragraph are athletic shirts or so-called "sweat shirts" with a raised-fiber inner side.

(f) *Multilayer fabric and wearing apparel with a film or coating on the uncovered or exposed surface.* Plastic film or plastic-coated fabric used, or intended for use, as the outer layer of disposable diapers is exempt from the requirements of the standard, provided that a full thickness of the assembled article passes the test in the standard otherwise applicable to the outer fabric or film when the flame is applied to the exposed or uncovered surface.

§ 1610.37 Reasonable and representative tests to support guaranties.

(a) *Purpose.* The purpose of this § 1610.37 is to establish requirements for reasonable and representative tests to support initial guaranties of products, fabrics, and related materials which are subject to the Standard for the Flammability of Clothing Textiles (the Standard, 16 CFR part 1610).

(b) *Statutory provisions.* (1) Section 8(a) of the Act (15 U.S.C. 1197(a)) provides that no person shall be subject to criminal prosecution under section 7 of the Act (15 U.S.C. 1196) for a violation of section 3 of the Act (15 U.S.C. 1192) if such person establishes a guaranty received in good faith to the effect that the product, fabric, or related material complies with the applicable flammability standard. A guaranty does not provide the holder any defense to an administrative action for an order to cease and desist from violation of the applicable standard, the Act, and the Federal Trade Commission Act (15 U.S.C. 45), nor to any civil action for injunction or seizure brought under section 6 of the Act (15 U.S.C. 1195).

(2) Section 8 of the Act provides for two types of guaranties:

(i) An initial guaranty based on "reasonable and representative tests" made in accordance with the applicable standard issued under the Act; and

(ii) A guaranty based on a previous guaranty, received in good faith, to the effect that reasonable and representative tests show conformance with the applicable standard.

(c) *Requirements.* (1) Each person or firm issuing an initial guaranty of a product, fabric, or related material subject to the Standard shall devise and implement a program of reasonable and representative tests to support such a guaranty.

(2) The term program of reasonable and representative tests as used in this § 1610.37 means at least one test with results demonstrating conformance with the Standard for the product, fabric or related material which is the subject of an initial guaranty. The program of reasonable and representative tests required by this § 1610.37 may include tests performed before the effective date of this section, and may include tests performed by persons or firms outside of the territories of the United States or other than the one issuing the initial guaranty. The number of tests and the frequency of testing shall be left to the discretion of the person or firm issuing the initial guaranty.

(3) In the case of an initial guaranty of a fabric or related material, a program of reasonable and representative tests may consist of one or more tests of the particular fabric or related material which is the subject of the guaranty, or of a fabric or related material of the same "class" of fabrics or related materials as the one which is the subject of the guaranty. For purposes of this § 1610.37, the term class means a category of fabrics or related materials having general constructional or finished characteristics, sometimes in association with a particular fiber, and covered by a class or type description generally recognized in the trade.

§ 1610.38 Maintenance of records by those furnishing guaranties.

(a) Any person or firm issuing an initial guaranty of a product, fabric, or related material which is subject to the Standard for the Flammability of Clothing Textiles (the Standard, 16 CFR part 1610) shall keep and maintain a record of the test or tests relied upon to support that guaranty. The records to be maintained shall show:

(1) The style or range number, fiber composition, construction and finish type of each textile fabric or related material covered by an initial guaranty; or the identification, fiber composition, construction and finish type of each textile fabric (including those with a nitrocellulose fiber, finish or coating), and of each related material, used or

contained in a product of wearing apparel covered by an initial guaranty.

(2) The results of the actual test or tests made of the textile fabric or related material covered by an initial guaranty; or of any fabric or related material used in the product of wearing apparel covered by an initial guaranty.

(3) When the person or firm issuing an initial guaranty has conducted the test or tests relied upon to support that guaranty, that person or firm shall also include with the information required by paragraphs (a)(1) and (2) of this section, a sample of each fabric or related material which has been tested.

(b) Persons furnishing guaranties based upon class tests shall maintain records showing:

(1) Identification of the class test.

(2) Fiber composition, construction and finish type of the fabrics, or the fabrics used or contained in articles of wearing apparel so guaranteed.

(3) A swatch of each class of fabrics guaranteed.

(c) Persons furnishing guaranties based upon guaranties received by them shall maintain records showing the guaranty received and identification of the fabrics or fabrics contained in articles of wearing apparel guaranteed in turn by them.

(d) The records referred to in this section shall be preserved for a period of 3 years from the date the tests were performed, or in the case of paragraph (c) of this section from the date the guaranties were furnished.

(e) Any person furnishing a guaranty under section 8(a) of the Act who neglects or refuses to maintain and preserve the records prescribed in this section shall be deemed to have furnished a false guaranty under the provisions of section 8(b) of the Act.

§ 1610.39 Shipments under section 11(c) of the Act.

(a) The invoice or other paper relating to the shipment or delivery for shipment in commerce of articles of wearing apparel or textile fabrics for the purpose of finishing or processing to render them not so highly flammable as to be dangerous when worn by individuals, shall contain a statement disclosing such purpose.

(b) An article of wearing apparel or textile fabric shall not be deemed to fall within the provisions of section 11(c) of the Act as being shipped or delivered for shipment in commerce for the purpose of finishing or processing to render such article of wearing apparel or textile fabric not so highly flammable under section 4 of the Act, as to be dangerous when worn by individuals, unless the shipment or delivery for

shipment in commerce of such article of wearing apparel or textile fabric is made directly to the person engaged in the business of processing or finishing textile products for the prearranged purpose of having such article of apparel or textile fabric processed or finished to render it not so highly flammable under section 4 of the Act, as to be dangerous when worn by individuals, and any person shipping or delivering for shipment the article of wearing apparel or fabric in commerce for such purpose maintains records which establish that the textile fabric or article of wearing apparel has been shipped for appropriate flammability treatment, and that such treatment has been completed, as well as records to show the disposition of such textile fabric or article of wearing apparel subsequent to the completion of such treatment.

(c) The importation of textile fabrics or articles of wearing apparel may be considered as incidental to a transaction involving shipment or delivery for shipment for the purpose of rendering such textile fabrics or articles of wearing apparel not so highly flammable under the provisions of section 4 of the Act, as to be dangerous when worn by individuals, if:

(1) The importer maintains records which establish that: (i) the imported textile fabrics or articles of wearing apparel have been shipped for appropriate flammability treatment, and

(ii) Such treatment has been completed, as well as records to show the disposition of such textile fabrics or articles of wearing apparel subsequent to the completion of such treatment.

(2) The importer, at the time of importation, executes and furnishes to the U.S. Customs and Border Protection an affidavit stating: These fabrics (or articles of wearing apparel) are dangerously flammable under the provisions of section 4 of the Act, and will not be sold or used in their present condition but will be processed or finished by the undersigned or by a duly authorized agent so as to render them not so highly flammable under the provisions of section 4 of the Flammable Fabrics Act, as to be dangerously flammable when worn by individuals. The importer agrees to maintain the records required by 16 CFR 1610.39(c)(1).

(3) The importer, if requested to do so by the U.S. Customs and Border Protection, furnishes an adequate specific-performance bond conditioned upon the complete discharge of the obligations assumed in paragraphs (c) (1) and (2) of this section.

(d) The purpose of section 11(c) of the Act is only to permit articles of wearing apparel or textile fabrics which are dangerously flammable to be shipped or delivered for shipment in commerce for the purpose of treatment or processing to render them not dangerously flammable. Section 11(c) does not in any other respect limit the force and effect of sections 3, 6, 7, and 9 of the Act. In particular, section 11(c) does not authorize the sale or offering for sale of any article of wearing apparel or textile fabric which is in fact dangerously flammable at the time of sale or offering for sale, even though the seller intends to ship the article for treatment prior to delivery to the purchaser or has already done so. Moreover, under section 3 of the Act a person is liable for a subsequent sale or offering for sale if, despite the purported completion of treatment to render it not dangerously flammable, the article in fact remains dangerously flammable.

§ 1610.40 Use of alternate apparatus, procedures, or criteria for tests for guaranty purposes.

(a) Section 8(a) of the Act provides that no person shall be subject to criminal prosecution under section 7 of the Act (15 U.S.C. 1196) for a violation of section 3 of the Act (15 U.S.C. 1192) if that person establishes a guaranty received in good faith which meets all requirements set forth in section 8 of the Act. One of those requirements is that the guaranty must be based upon "reasonable and representative tests" in accordance with the applicable standard.

(b) Subpart A of this part 1610 prescribes apparatus and procedures for testing fabrics and garments subject to its provisions. See §§ 1610.5 & 1610.6. Subpart A prescribes criteria for classifying the flammability of fabrics and garments subject to its provisions as "Normal flammability, Class 1," "Intermediate flammability, Class 2," and "Rapid and Intense Burning, Class 3." See § 1610.4. Sections 3 and 4 of the Act prohibit the manufacture for sale, importation into the United States, or introduction in commerce of any fabric or article of wearing apparel subject to the Standard which exhibits "rapid and intense burning" when tested in accordance with the Standard. See 16 CFR part 1609.

(c) The Commission recognizes that for purposes of supporting guaranties, "reasonable and representative tests" could be either the test in Subpart A of this part, or alternate tests which utilize apparatus or procedures other than those in Subpart A of this part. This § 1610.40 sets forth conditions under

which the Commission will allow use of alternate tests with apparatus or procedures other than those in Subpart A of this part to serve as the basis for guaranties.

(d)(1) Persons and firms issuing guaranties that fabrics or garments subject to the Standard meet its requirements may base those guaranties on any alternate test utilizing apparatus or procedures other than those in Subpart A of this part, if such alternate test is as stringent as, or more stringent than, the test in Subpart A of this part. The Commission considers an alternate test to be "as stringent as, or more stringent than" the test in Subpart A of this part if, when testing identical specimens, the alternate test yields failing results as often as, or more often than, the test in Subpart A of this part. Any person using such an alternate test must have data or information to demonstrate that the alternate test is as stringent as, or more stringent than, the test in Subpart A of this part.

(2) The data or information required by this paragraph (d) of this section to demonstrate equivalent or greater stringency of any alternate test using apparatus or procedures other than those in Subpart A of this part must be in the possession of the person or firm desiring to use such alternate test before the alternate test may be used to support guaranties of items subject to the Standard.

(3) The data or information required by paragraph (d) of this section to demonstrate equivalent or greater stringency of any alternate test using apparatus or procedures other than those in Subpart A of this part must be retained for as long as that alternate test is used to support guaranties of items subject to the Standard, and for one year thereafter.

(e) Specific approval from the Commission in advance of the use of any alternate test using apparatus or procedures other than those in Subpart A is not required. The Commission will not approve or disapprove any specific alternate test utilizing apparatus or procedures other than those in Subpart A of this part.

(f) Use of any alternate test to support guaranties of items subject to the Standard without the information required by this section may result in violation of section 8(b)), of the Act (15 U.S.C. 1197(b)), which prohibits the furnishing of a false guaranty.

(g) The Commission will test fabrics and garments subject to the Standard for compliance with the Standard using the apparatus and procedures set forth in Subpart A of this part. The Commission

will consider any failing results from compliance testing as evidence that:

(1) The manufacture for sale, importation into the United States, or introduction in commerce of the fabric or garment which yielded failing results was in violation of the Standard and of section 3 of the Act; and

(2) The person or firm using the alternate test as the basis for a guaranty has furnished a false guaranty, in violation of section 8(b) of the Act. (Reporting requirements contained in paragraph (d) were approved by Office of Management and Budget under control number 3041-0024.)

Subpart C—Interpretations and Policies

§ 1610.61 Reasonable and representative testing to assure compliance with the standard for the clothing textiles.

(a) *Background.* (1) The CPSC administers the Flammable Fabrics Act ("the Act"), 15 U.S.C. 1191-1204. Under the Act, among other things, the Commission enforces the Flammability Standard for Clothing Textiles ("the Standard"), 16 CFR part 1610. That Standard establishes requirements for the flammability of clothing and textiles intended to be used for clothing (hereinafter "textiles").

(2) The Standard applies both to fabrics and finished garments. The Standard provides methods of testing the flammability of textiles, and sets forth the requirements that textiles must meet to be classified into one of three classes of flammability (classes 1, 2 and 3). § 1610.4. Class 1 textiles, those that exhibit normal flammability, are acceptable for use in clothing.

§ 1610.4(a)(1) & (2). Class 2 textiles, applicable only to raised fiber surfaces, are considered to be of intermediate flammability, but may be used in clothing. § 1610.4(b)(1) & (2). Finally, Class 3 textiles, those that exhibit rapid and intense burning, are dangerously flammable and may not be used in clothing. § 1610.4(c)(1) & (2). The manufacture for sale, offering for sale, importation into the U.S., and introduction or delivery for introduction of Class 3 articles of wearing apparel are among the acts prohibited by section 3(a) of the Act, 15 U.S.C. 1192(a).

(3) CPSC currently uses retail surveillance, attends appropriate trade shows, follows up on reports of noncompliance and previous violations, and works with U.S. Customs and Border Protection in an effort to find textiles that violate CPSC's standards. The Commission has a number of enforcement options to address prohibited acts. These include bringing

seizure actions in federal district court against violative textiles, seeking an order through an administrative proceeding that a firm cease and desist from selling violative garments, pursuing criminal penalties, or seeking the imposition of civil penalties for "knowing" violations of the Act. Of particular relevance to the latter two remedies is whether reasonable and representative tests were performed demonstrating that a textile or garment meets the flammability standards for general wearing apparel. Persons who willfully violate flammability standards are subject to criminal penalties.

(4) Section 8(a) of the Act, 15 U.S.C. 1197(a), exempts a firm from the imposition of criminal penalties if the firm establishes that a guaranty was received in good faith signed by and containing the name and address of the person who manufactured the guaranteed wearing apparel or textiles or from whom the apparel or textiles were received. A guaranty issued by a person who is not a resident of the United States may not be relied upon as a bar to prosecution. 16 CFR 1608.4. The guaranty must be based on the exempted types of fabrics or on reasonable and representative tests showing that the fabric covered by the guaranty or used in the wearing apparel covered by the guaranty is not so highly flammable as to be dangerous when worn by individuals, i.e., is not a Class 3 material. (The person proffering a guaranty to the Commission must also not, by further processing, have affected the flammability of the fabric, related material or product covered by the guaranty that was received.) Under § 1610.37, a person, to issue a guaranty, should first evaluate the type of fabric to determine if it meets testing exemptions in accordance with § 1610.1(d). (Some textiles never exhibit unusual burning characteristics and need not be tested.) § 1610.1(d). Such textiles include plain surface fabrics, regardless of fiber content, weighing 2.6 oz. or more per sq. yd., and plain and raised surface fabrics made of acrylic, modacrylic, nylon, olefin, polyester, wool, or any combination of these fibers, regardless of weight.) If no exemptions apply, the person issuing

the guaranty must devise and implement a program of reasonable and representative tests to support the guaranty. The number of tests and frequency of testing is left to the discretion of that person, but at least one test is required.

(5) In determining whether a firm has committed a "knowing" violation of a flammability standard that warrants imposition of a civil penalty, the CPSC considers whether the firm had actual knowledge that its products violated the flammability requirements. The CPSC also considers whether the firm should be presumed to have the knowledge that would be possessed by a reasonable person acting in the circumstances, including knowledge that would have been obtainable upon the exercise of due care to ascertain the truth of representations. 15 U.S.C. 1194(e). The existence of results of flammability testing based on a reasonable and representative program and, in the case of tests performed by another entity (such as a guarantor), the steps, if any, that the firm took to verify the existence and reliability of such tests, bear directly on whether the firm acted reasonably in the circumstances.

(b) *Applicability.* (1) When tested for flammability, a small number of textile products exhibit variability in the test results; that is, even though they may exhibit Class 1 or Class 2 burning characteristics in one test, a third test may result in a Class 3 failure. Violative products that the Commission has discovered between 1994 and 1998 include sheer 100% rayon skirts and scarves; sheer 100% silk scarves; 100% rayon chenille sweaters; rayon/nylon chenille and long hair sweaters; polyester/cotton and 100% cotton fleece/sherpa garments, and 100% cotton terry cloth robes. Between August 1994 and August 1998, there have been 21 recalls of such dangerously flammable clothing, and six retailers have paid civil penalties to settle Commission staff allegations that they knowingly sold garments that violated the general wearing apparel standard.

(2) The violations and resulting recalls and civil penalties demonstrate the critical necessity for manufacturers,

distributors, importers, and retailers to evaluate, prior to sale, the flammability of garments made from the materials described above, or to seek appropriate guaranties that assure that the garments comply. Because of the likelihood of variable flammability in the small group of textiles identified above, one test is insufficient to assure reasonably that these products comply with the flammability standards. Rather, a person seeking to evaluate garments made of such materials should assure that the program tests a sufficient number of samples to provide adequate assurance that such textile products comply with the general wearing apparel standard. The number of samples to be tested, and the corresponding degree of confidence that products tested will comply, are to be specified by the individual designing the test program. However, in assessing the reasonableness of a test program, the Commission staff will specifically consider the degree of confidence that the program provides.

(c) *Suggestions.* The following are some suggestions to assist in complying with the Standard:

(1) Purchase fabrics or garments that meet testing exemptions listed in § 1610.1(d). (If buyers or other personnel do not have skills to determine if the fabric is exempted, hire a textile consultant or a test lab for an evaluation.)

(2) For fabrics that are not exempt, conduct reasonable and representative testing before cutting and sewing, using standard operating characteristic curves for acceptance sampling to determine a sufficient number of tests.

(3) Purchase fabrics or garments that have been guaranteed and/or tested by the supplier using a reasonable and representative test program that uses standard operating characteristic curves for acceptance sampling to determine a sufficient number of tests. Firms should also receive and maintain a copy of the guaranty.

(4) Periodically verify that your suppliers are actually conducting appropriate testing.

BILLING CODE 6355-01-P

Figure 1 to Part 1610—Sketch of Flammability Apparatus

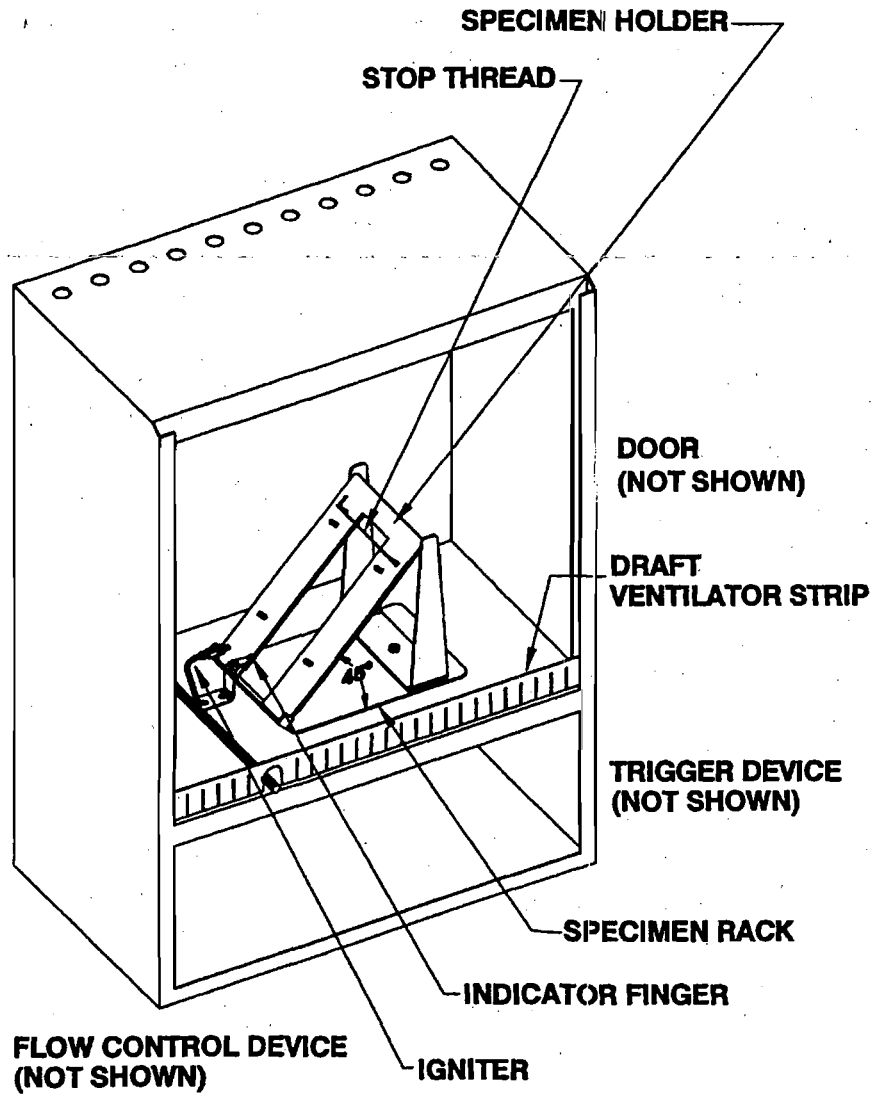

SKETCH OF FLAMMABILITY APPARATUS
FIGURE 1

Figure 2 to Part 1610—Flammability Apparatus Views

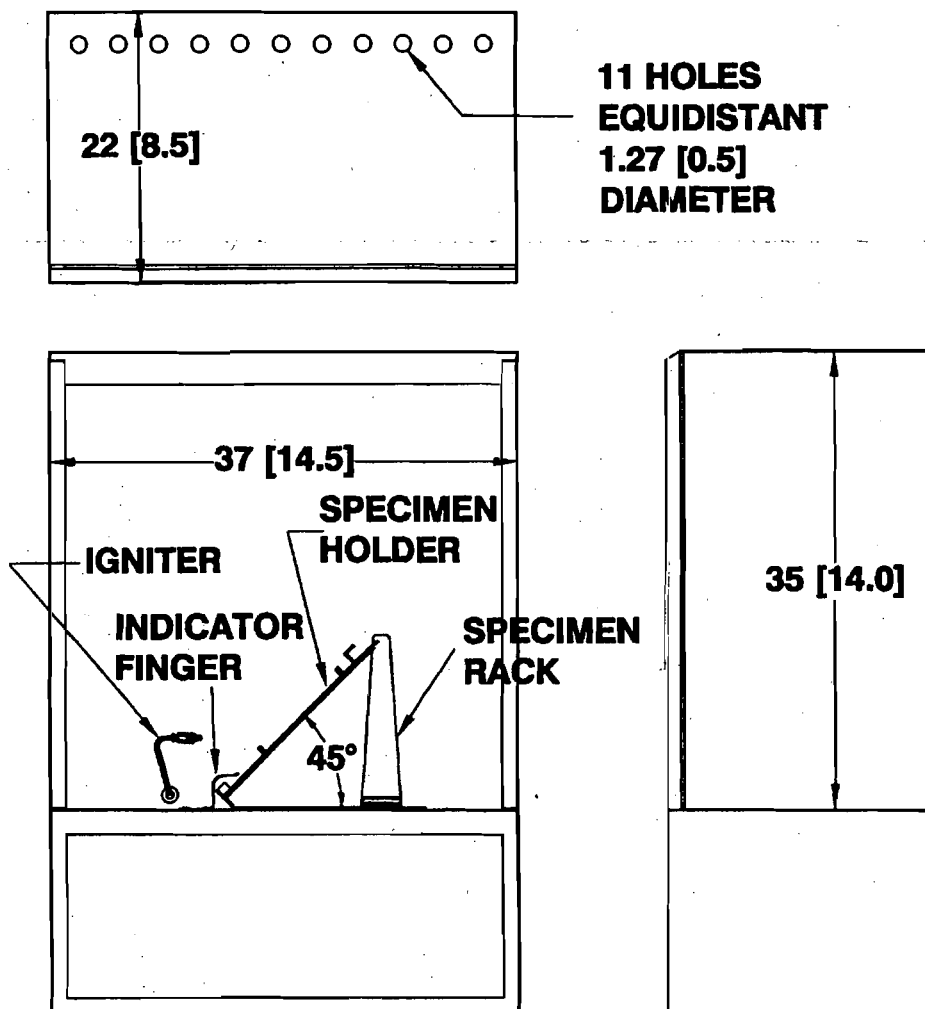

**NOTE: DIMENSIONS IN
CENTIMETERS [INCHES]**

**FLAMMABILITY APPARATUS VIEWS
FIGURE 2**

Figure 3 to Part 1610—Specimen Holder Supported in Specimen Rack

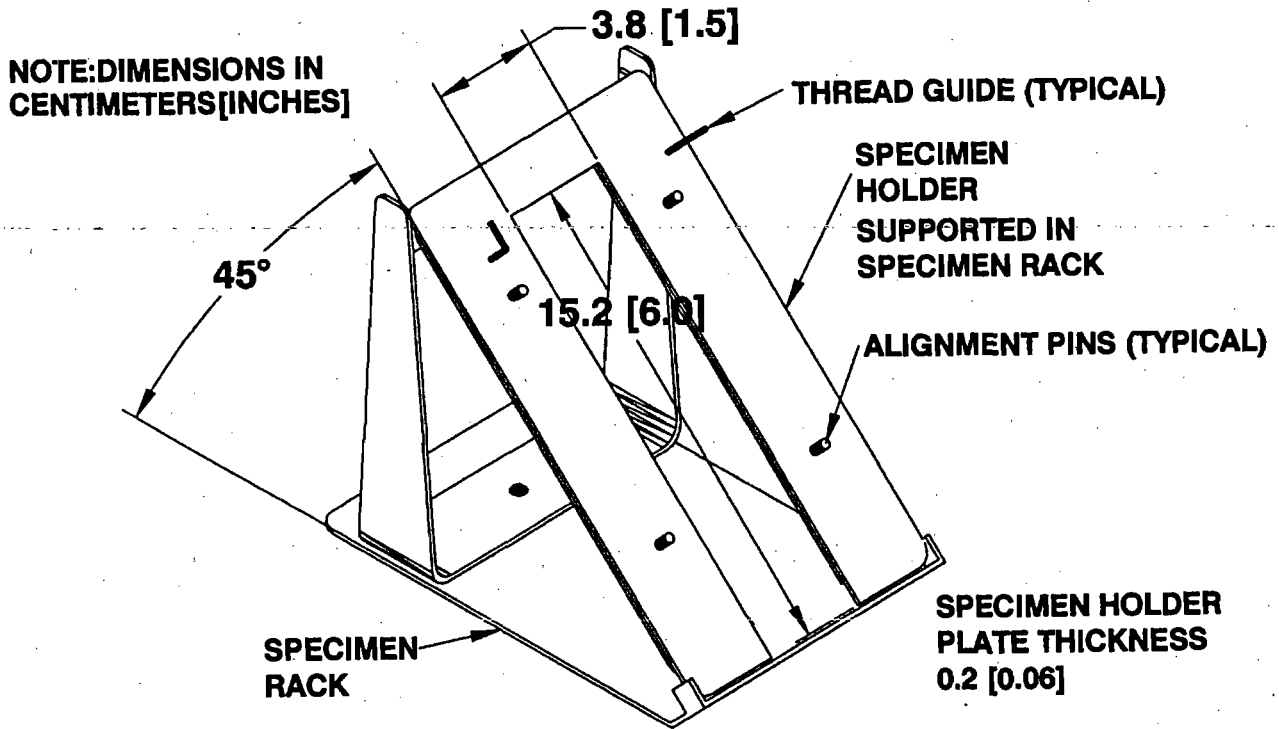

SPECIMEN HOLDER SUPPORTED IN SPECIMEN RACK
FIGURE 3

Figure 4 to Part 1610—Igniter

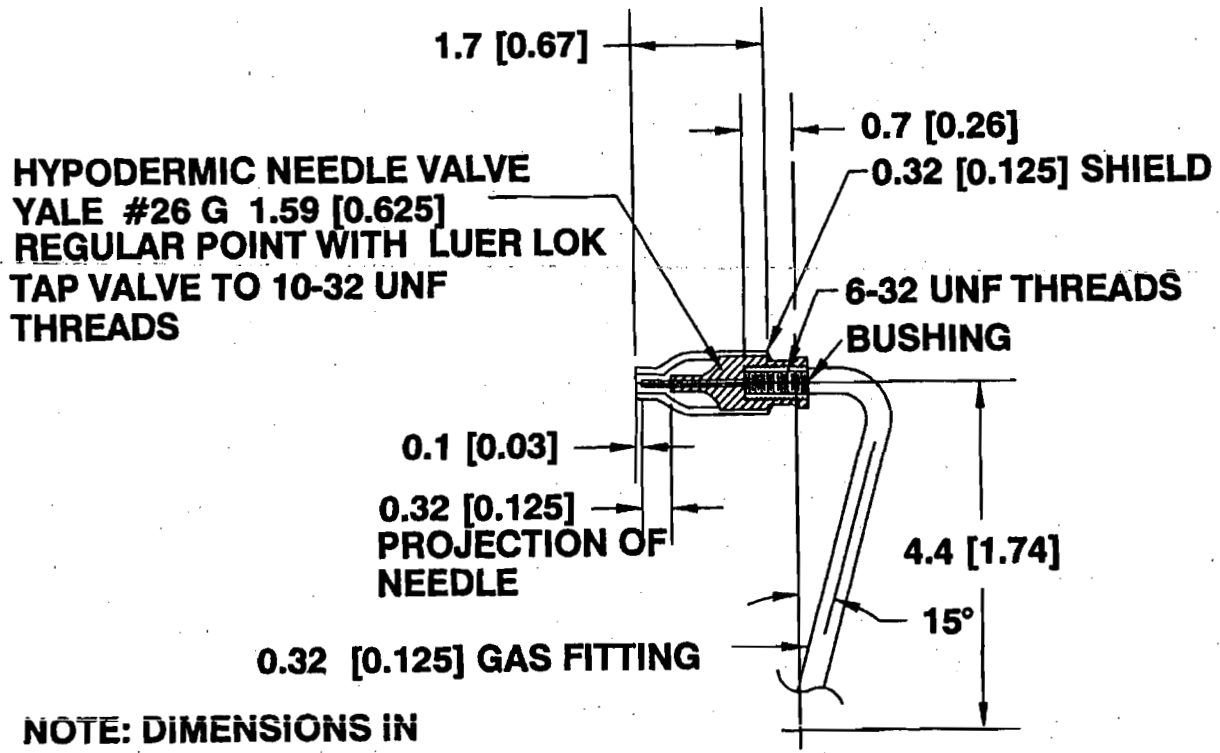

NOTE: DIMENSIONS IN
CENTIMETERS [INCHES]

IGNITER
FIGURE 4

Figure 5 to Part 1610—Brushing Device

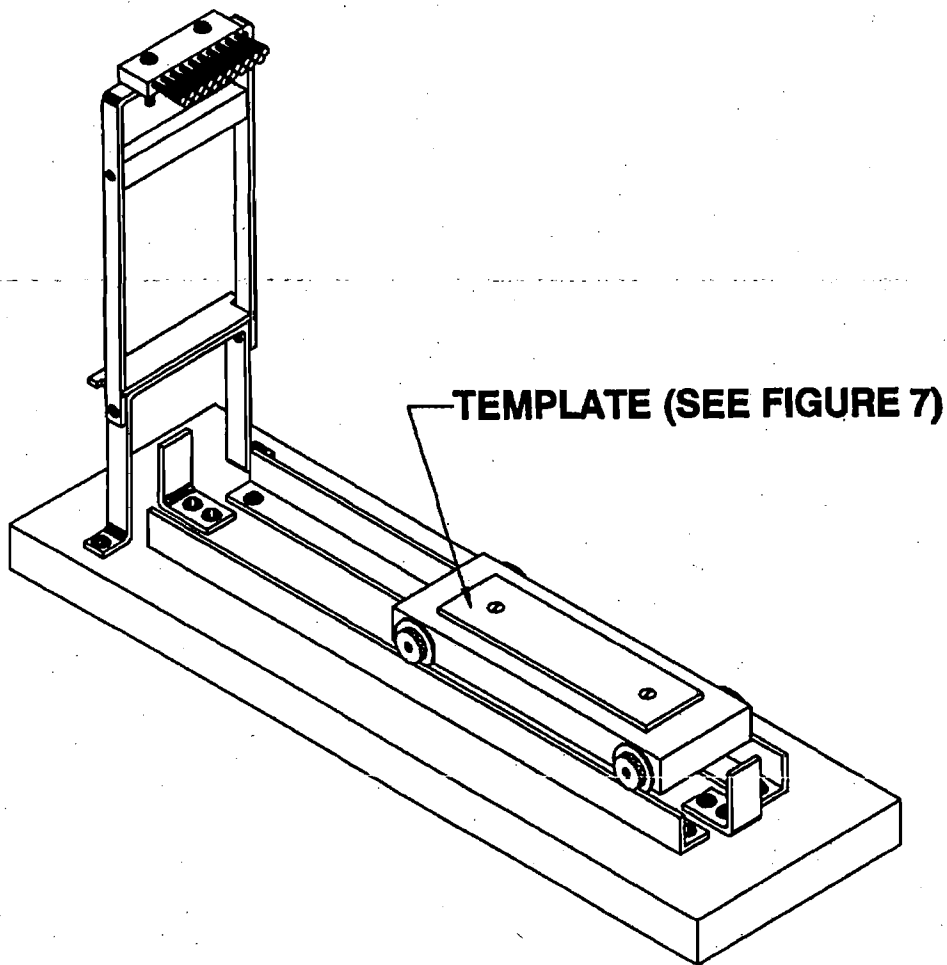

**BRUSHING DEVICE
FIGURE 5**

Figure 6 to Part 1610—Brush

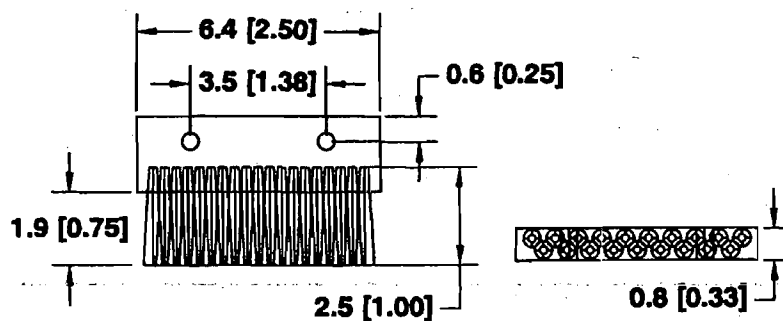

**BRUSH CONSISTS OF NYLON BRISTLES
0.004 [0.016] DIAMETER
20 BRISTLES PER TUFT AND 4 TUFTS PER INCH**

**NOTE: DIMENSIONS IN
CENTIMETERS [INCHES]**

**BRUSH
FIGURE 6**

Figure 7 to Part 1610—Template

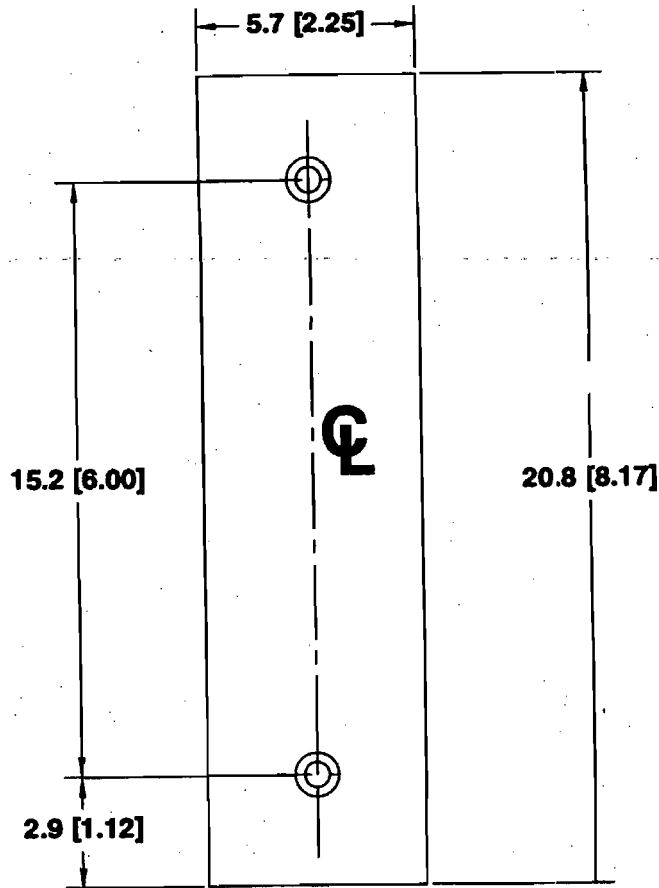

**TWO HOLES Ø 0.16 [0.0625]
COUNTERSINK FOR
FLAT HEAD SCREW**

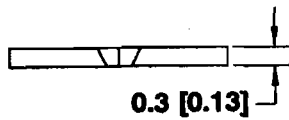

**NOTE: DIMENSIONS IN
CENTIMETERS [INCHES]**

**TEMPLATE
FIGURE 7**

Dated: February 13, 2007.

Todd A. Stevenson,
Secretary, Consumer Product Safety
Commission.

Note: The following appendix will not
appear in the Code of Federal Regulations.

Appendix—List of Relevant Documents

(The following documents are available
from the Commission's Office of the
Secretary, Consumer Product Safety
Commission, Room 502, 4330 East West
Highway, Bethesda, Maryland 20814-4408;
telephone (301) 504-7923 or from the
Commission's Web site ([http://
www.cpsc.gov/library/foia/foia.html](http://www.cpsc.gov/library/foia/foia.html))).

1. Briefing memorandum from Jacqueline
Elder, Assistant Executive Director, EXHR

and Patricia K. Adair, Project Manager,
Directorate for Engineering Sciences, to the
Commission, "Draft Notice of Proposed
Rulemaking to Amend the Standard for the
Flammability of Clothing Textiles, 16 CFR
part 1610," January 10, 2007.

2. Memorandum from David Miller, EPHA,
Directorate for Epidemiology, to Patricia K.
Adair, Project Manager, "General Wearing
Apparel Fires," November 7, 2006.

3. Memorandum from Terrance R. Karels,
Directorate for Economic Analysis, to Patricia
K. Adair, Project Manager, "Amendment to
the Clothing Textiles Standard," November
21, 2006.

4. Memorandum from Gail Stafford and
Weiying Tao, Directorate for Laboratory
Sciences, to Patricia K. Adair, Project
Manager, "Response to Comments Received

as a Result of the Advance Notice of
Proposed Rulemaking (ANPR) for Updating
the Standard for the Flammability of Clothing
Textiles," November 21, 2006.

5. Memorandum from Marilyn Borsari,
Office of Compliance and Field Operations,
to Patricia K. Adair, Project Manager, "ANPR
to Amend the Standard for the Flammability
of Clothing Textiles, 16 CFR part 1610,
November 22, 2006.

6. Memorandum from Patricia K. Adair,
ESFS to the File, July 28, 2006.

7. Memorandum from Cassandra Prioleau,
Ph.D., Directorate for Health Sciences, to
Patricia K. Adair, Project Manager, "Toxicity
Review of Perchloroethylene," July 6, 2006.

[FR Doc. 07-779 Filed 2-26-07; 8:45 am]

BILLING CODE 6355-01-P

TAB B



UNITED STATES
CONSUMER PRODUCT SAFETY COMMISSION
WASHINGTON, DC 20207

Memorandum

Date: December 27, 2007

TO : Patricia Adair
Project Manager, Wearing Apparel Standard Update
Directorate for Engineering Sciences
Division of Combustion and Fire Sciences

THROUGH: Russell Roegner, Ph.D. *R for R Roegner*
Associate Executive Director
Directorate for Epidemiology

Kathleen Stralka, Director *Stralka*
Division of Hazard Analysis

FROM : David Miller, EPHA *D E M*

SUBJECT : General Wearing Apparel Fires – Fatalities and Emergency Department Treated Injuries

On February 27, 2007, the Commission issued a notice of proposed rulemaking (NPR) to amend the *Standard for the Flammability of Clothing Textiles* and requested public comments on the proposed amendments. In support of this effort, this memorandum provides estimates of fatal and non-fatal injuries to all age groups caused by ignition of all types of consumer clothing.

Methodology

a) Fatal Injuries

Data Source: Mortality data were based on the Compressed Mortality File prepared by the U.S. Department of Health and Human Services, Centers for Disease Control and Prevention, National Center for Health Statistics (NCHS), CDC WONDER On-line Database.¹ These data are based on records of all deaths that occurred in the fifty states and the District of Columbia. Thus, they represent counts of deaths rather than estimates. Deaths to foreign residents are excluded. U.S. Census population data used to calculate death rates are included in this database.

¹ Compressed Mortality File 1979 – 1998 and 1999 – 2004 compiled from CMF 1968 – 1988, Series 20, No. 2A 2000, CMF 1989 – 1998, Series 20, No. 2E 2003 and CMF 1999-2002, Series 20, No. 2H 2004 on CDC WONDER On-line Database, U.S. Department of Health and Human Services, Centers for Disease Control and Prevention, National Center for Health Statistics (NCHS).

Data Selected: Fatal injuries involving clothing ignition were identified through the coded variable “Underlying cause of death” which is defined by the World Health Organization (WHO) as “the disease or injury which initiated the train of events leading directly to death, or the circumstances of the accident or violence which produced the fatal injury,” as reported on the death certificate. The classification system used to code underlying cause of death underwent a major revision in 1999. Clothing-related fire fatalities were identified in the two systems as follows:

ICD9. 1998 and previous years: External Cause of Death=Accident Caused by Ignition of Clothing, E893

ICD10. 1999 and subsequent years: External Cause of Morbidity and Mortality=Exposure to Ignition or Melting of Nightwear, X05, and External Cause of Morbidity and Mortality=Exposure to Ignition or Melting of Other Clothing and Apparel, X06

Discussion: The ICD9 and ICD10 mortality reporting systems are quite different. A comparison of the two systems by NCHS indicated that the change in system has resulted in a discontinuity in cause-of-death trends for many causes.² For the group “Accidental Exposure to Smoke, Fire and Flames” which includes clothing ignitions as well as other fire causes, the estimated comparability ratio was 0.9743 with a 95 percent confidence interval of 0.9568 and 0.9918, indicating that fatalities reported under ICD10 were 97.43 percent of the ICD9 level. Application of this ratio to the ICD10 death counts results in only minor changes, an estimated increase of about 3 deaths annually for the level of deaths reported.

Death rates have been age-adjusted to “remove” the effects of population age distributions that change over time so that meaningful comparisons of risk can be made between populations with different proportions of people at high, or low, risk. The populations used to calculate rates were the census population estimates for the year under study³.

b) Non-fatal Injuries Treated in Emergency Departments

Data Source: Estimates of non-fatal burn injuries associated with clothing ignition were based on data reported through CPSC’s National Electronic Injury Surveillance System (NEISS), a probability sample of about 100 hospitals that represent all hospitals with emergency departments in the U.S. Participating hospitals capture all injuries associated with consumer products and recreational activities that are treated in their emergency departments, allowing calculation of national estimates of injuries by product, along with confidence intervals associated with those estimates.

² Anderson, RN et al, “Comparability of Cause of Death Between ICD-9 and ICD-10: Preliminary Estimates,” National Vital Statistics Reports, Vol. 49, No. 2, Department of Health and Human Services, Centers for Disease Control and Prevention, National Center for Health Statistics, National Vital Statistics System, May 18, 2001.

³ These population estimates are taken from the CDC WONDER website.

Data Selected: Injuries selected met all of the following criteria:
 Date of Treatment 1/1/96 – 12/31/05
 Patient Age: All ages
 Product codes: 1644-Nightwear, 1645-Daywear, 1646-Outerwear,
 1677-Other Clothing, and 1658-Clothing Not Specified.
 Diagnoses: 51-Thermal Burns or 47-Burns Not Specified
 Narrative: Comments in the record indicated ignition of clothing

Discussion: Since NEISS estimates are based on a probability sample, if the sample size of specific categories of-interest is too small the estimates produced may have large variability associated with them. If estimates are either smaller than 1,200, or are based on a sample smaller than 20, or have a coefficient of variation greater than 0.33, then they are not reported. An example of this is the 'Held for Observation' disposition in Table 5. One fatal injury involving clothing ignition was reported from a NEISS hospital during this period. It was excluded from the non-fatal injury estimates presented.

Results

a) Fatalities

NCHS mortality data indicated that fatalities caused by clothing ignition have experienced a general decline. Continuing a decline begun earlier, clothing fatalities declined from 311 fatalities in 1980 to 129 fatalities (adjusted) in 2004, the most recent year of available data (Figure 1). The age-adjusted death rates associated with clothing ignition declined from 1.5 deaths per million U.S. population to 0.4 deaths per million during this period. An average 120 clothing fire related fatalities occurred annually during 2002 – 2004, the years reported in ICD10 format (Table 1).

Figure 1

Clothing Fire Fatalities, 1980 to 2004

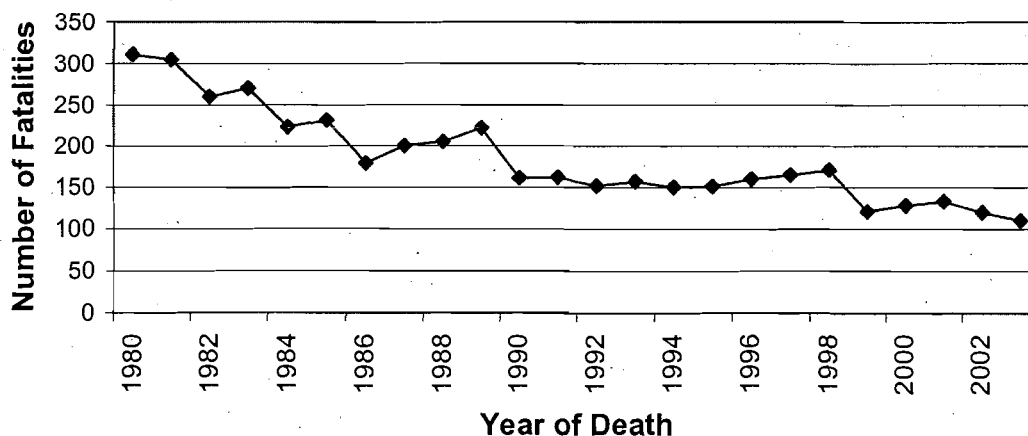

Source: NCHS Mortality data, CDC WONDER On-line database.

Table 1. Clothing Ignition Fatalities, 1980 - 2004

Year	Count	Age- Adjusted Rate/Million Population
1980	311	1.5
1981	305	1.4
1982	260	1.2
1983	270	1.2
1984	223	1.0
1985	232	1.0
1986	179	0.8
1987	200	0.8
1988	205	0.9
1989	222	0.9
1990	161	0.6
1991	162	0.6
1992	152	0.6
1993	157	0.6
1994	150	0.6
1995	151	0.5
1996	160	0.6
1997	165	0.6
1998	171	0.6
1999	121*	0.4
2000	128*	0.4
2001	133*	0.5
2002	120*	0.4
2003	110*	0.4
2004	129*	0.4
Mean 02 – 04	120*	0.4

Note: Solid line designates change of data coding system; ICD9 above the line, ICD10 below the line.

* Data for 1999 – 2004 was adjusted to compensate for the change in data system.

Source: NCHS Mortality data, CDC WONDER On-line database.

Death rates among different age groups varied considerably (Table 2). Based on the mean unadjusted counts by age group for the years 2002 – 2004, death rates generally increased with age. All age groups of 65 and older had death rates higher than the mean of the whole population (assigned an index of 1). The age group of 65 to 74 had a rate about 3 times higher, those ages 75 to 84 had a rate over 7 times higher, and those ages 85 and older had a rate 13 times higher.

Table 2. Clothing Ignition Fatalities, Year by Age Group, 1994 – 2004

Year	Age Group									
	Total	<5	5 to 14	15-24	25 - 44	45-64	65 - 74	75-84	85+	Unk
1994	150	3	0	3	12	24	27	44	37	0
1995	151	2	0	3	10	25	32	49	29	1
1996	160	2	0	0	16	18	32	53	39	0
1997	165	1	2	3	12	33	27	48	39	0
1998	171	3	3	4	14	30	31	49	37	0
1999	118	0	2	0	10	19	22	39	26	0
2000	125	0	1	4	6	18	21	49	26	0
2001	130	1	0	0	4	21	31	43	30	0
2002	117	0	2	0	2	26	19	42	25	1
2003	107	1	1	0	6	24	24	26	25	0
2004	126	0	0	0	6	26	23	43	28	0
Mean 02-04	117	0 ⁴	1	0 ⁵	5	25	22	37	26	0
Mean Rate/Mill	0.40	0.02	0.02	0	0.06	0.37	1.20	2.87	5.51	-
Indexed Rate	1	0.04	0.06	0	0.14	0.92	2.99	7.16	13.74	-

Note: Solid line designates change of data coding system; ICD9 above the line, ICD10 below the line.

ICD10 counts have not been adjusted.

Source: NCHS Mortality data, CDC WONDER On-line database.

b) Non-Fatal Injuries

In contrast to the decline in the number of clothing fire-related deaths, estimated non-fatal injuries have not differed much in the most recent ten years (Table 3). A statistical test of significance gave no evidence of a trend in the data (p -value=0.886). During the most recent three years (2003 – 2005), there were an estimated 3,947 non-fatal injuries associated with clothing ignition (95% confidence interval of 3,154 – 4,740) treated in hospital emergency departments annually. This estimate represents a mean annual rate of 13.6 injuries per one million population. Unlike the rates seen for deaths, non-fatal injuries had some of its highest rates of occurrence among patients ages 5 to 14 and 15 to 24, about one and a half times the rate for all ages combined (Table 4).

⁴ This number rounds down to 0. There was one fatality of a child under five during the period 2002 – 2004.

⁵ This number is exactly 0. There were no fatal victims between ages 15 and 24 during the period 2002 – 2004.

Table 3. Estimated Non-Fatal Burn Injuries Associated with Clothing Ignition, Treated in Hospital Emergency Departments, 1996 – 2005

Year	Estimate	Frequency	CV	95% Confidence Interval	Rate/Million Population
1996	3,179	105	0.28	(1,437 - 4,921)	11.8
1997	3,826	101	0.15	(2,709 - 4,943)	14.0
1998	3,641	107	0.14	(2,664 - 4,618)	13.2
1999	4,702	125	0.13	(3,492 - 5,912)	16.8
2000	3,740	108	0.15	(2,617 - 4,863)	13.3
2001	3,793	109	0.13	(2,796 - 4,790)	13.3
2002	3,528	116	0.15	(2,480 - 4,576)	12.2
2003	3,722	115	0.15	(2,647 - 4,797)	12.8
2004	4,326	113	0.14	(3,105 - 5,547)	14.7
2005	3,793	111	0.16	(2,542 - 4,904)	12.8
Mean 2003 – 2005	3,947	113	0.10	(3,154 - 4,740)	13.6

Source: NEISS and Census population estimates, U.S. Consumer Product Safety Commission/EPHA

Table 4. Estimated Non-Fatal Burn Injuries Associated with Clothing Ignition By Age , Treated in Hospital Emergency Departments, 2003 – 2005 Annual Average

Age Group (Years)	Annual Estimate	Average NEISS cases per year	CV	95% Confidence Interval	Rate/Million Population	Indexed Rate
Less Than 5	*	4	*	*	*	*
5 - 14	788	28	0.15	(549, 1,027)	19.2	1.4
15 - 24	1,013	24	0.17	(680, 1,346)	24.6	1.8
25 - 44	575	18	0.18	(367, 783)	6.8	0.5
45 - 64	712	22	0.19	(450, 974)	10.4	0.8
65+	720	17	0.19	(457, 983)	20.0	1.5
Total	3,947	113	0.10	(3,154, 4,740)	13.6	1

Source: NEISS and Census population estimates, U.S. Consumer Product Safety Commission/EPHA

* Sample size is too small to support estimation.

Based on the total estimated injuries for this 3-year period, about 25 percent (941 out of 3,947) of the estimated non-fatal injuries were serious enough to be either treated and admitted or treated and transferred to another hospital for treatment, e.g., a burn center. In contrast, among all consumer product-related injuries seen at the emergency department during this period an estimated 5 percent were hospitalized or transferred for treatment.

Table 5. Estimated Non-Fatal Burn Injuries Associated with Clothing Ignition by Disposition, Treated in Hospital Emergency Departments, 2003 – 2005, Annual Average

Emergency Department Disposition	Annual Estimate	Percent	Average NEISS Cases per Year	CV	95% Confidence Interval
Treated & Released	2,969	75	237	0.11	(2,355, 3,583)
Treated & Transferred	498	13	10	0.22	(283, 714)
Treated & Admitted	443	11	22	0.28	(196, 690)
Held for Observation	*	*	1	*	*
Left Without Being Seen	*	*	1	*	*
Disposition Not Recorded	*	*	1	*	*
Total	3,947	100	113	0.10	(3,154, 4,740)

* Sample size is too small to support estimation.

Source: NEISS, U.S. Consumer Product Safety Commission/EPHA

More than 80 percent (an estimated 3,186 of 3,947) of clothing ignition-related non-fatal injuries involved some type of daywear, such as shirts, pants, dresses, etc. Clothing accessories such as hats are not covered by the General Wearing Apparel Standard and are not included here.

Discussion:

Mortality data from NCHS indicated that there has been a general decline in clothing ignition-related fatalities since 1980. Some part of the decrease between 1998 and subsequent years may be due to the change in the mortality reporting system, although historic data on clothing ignitions reveal similar levels of change in earlier years.

The difference in the age group distributions of fatalities and non-fatal injuries associated with clothing ignition was quite striking. Among fatal clothing ignitions, death rates rose dramatically with age, first rising above the average in the age group of 65 to 74. Among non-fatal clothing ignitions, rates higher than average occurred among those ages 5 to 14 and 15 to 24 as well as among those ages 65 and older. This may indicate that the fire *incidence* rate may not rise with age but that the effects of the injury do, particularly among the very oldest age groups. However, even the non-fatal injuries appeared to be more severe on average than hospital emergency room-treated injuries overall.

Since a special study of clothing fire incidents was not conducted, only general information about the type of clothing involved has been reported here. More detailed information about the injury scenarios and the clothing involved would require systematic follow-up investigations of clothing fires involving all age groups and clothing types.

Summary:

Mortality data indicated that fires involving clothing ignition resulted in 120 fatalities annually during the most recent years for which data was available (2002 – 2004). Population fatality rates increased with age. In addition, an estimated 3,900 non-fatal injuries were treated in hospital emergency departments annually (2003 – 2005). Among these non-fatal injuries, 25 percent were severe enough to require admission to the hospital. More than 75 percent of the clothing fire-related non-fatal injuries involved some form of daywear.

TAB C



United States
CONSUMER PRODUCT SAFETY COMMISSION
4330 East-West Highway
Bethesda, Maryland, 20814

MEMORANDUM

DATE: May 15, 2007

TO : ES

Through: Todd A. Stevenson, Secretary, OS

FROM : Martha A. Kosh, OS

SUBJECT: Proposed Changes to Textile Flammability Standard

ATTACHED ARE COMMENTS ON THE CF 07-2

<u>COMMENT</u>	<u>DATE</u>	<u>SIGNED BY</u>	<u>AFFILIATION</u>
CF 07-2-1	4/04/07	Ronald Pacheco Tech. Director Softlines	STR 10 Water Street Enfield, CT 06082
CF 07-2-2	5/14/07	Philip Wakelyn Ph.D., Consultant	National Cotton Council of America 1521 New Hampshire Ave., NW Washington, DC 20036
CF 07-2-3	5/08/07	Ellen Roaldi Sr. Technical Consulting Specialist Jennifer Hargrave Sr. Regulatory Consulting Specialist	Bureau Veritas Consumer Products Services, Inc. 100 Northpointe Parkway Buffalo, NY 14228
CF 07-2-4	5/14/07	Guo Lisheng Deputy Director	China WTO/TBT National Notification & Enquiry Center No. 9 Ma Dian Dong Lu, Hai Dian District, Beijing

Proposed Changes to Textile Flammability Standard

CF 07-2-5	5/14/07	Jennifer Counts Section Head	The Procter & Gamble Co. Fabric & Home Care Innovation Center 5299 Spring Grove Ave. Cincinnati, OH 45217
CF 07-2-6	5/14/07	Karen Kyлло Director, Textile Services	North American Retail Initiative Consumer Goods 70 Diamond Rd. Springfield, NJ 07081
CF 07-2-7	5/14/07	Hardy Poole Director, Technical and Regulatory Affairs	National Textile Assoc. 6 Beacon St, Suite 1125 Boston, MA 02108
CF 07-2-8	5/31/07	Stephen Lamar Executive Vice President	American Apparel & Footwear Association 1601 N Kent St, 12 th Fl Arlington, VA 22209

TAB D



UNITED STATES
CONSUMER PRODUCT SAFETY COMMISSION
WASHINGTON, DC 20207

Memorandum

Date: October 22, 2007

TO : Patricia Adair, Project Manager, Clothing Textiles Standard Update,
Directorate for Engineering Sciences

THROUGH: Andrew G. Stadnik, P.E., Associate Executive Director, *AGS*
Directorate for Laboratory Sciences
Edward W. Krawiec, P.E., Director Division of Engineering *EWK*

FROM : Gail Stafford, Textile Technologist, Division of Engineering *GS*
Weiying Tao, Textile Technologist, Division of Engineering *WT*

SUBJECT : Response to Comments Received on the Notice of Proposed Rulemaking
(NPR) for Updating the Standard for the Flammability of Clothing Textiles

The Directorate for Laboratory Sciences (LS) was asked to address several issues identified in the comments received on the NPR for updating the Standard for the Flammability of Clothing Textiles (16 CFR Part 1610). This memorandum summarizes the issues identified and presents the staff responses to them.

COMMENTS ABOUT DEFINITIONS

Comment: One commenter (# 3) suggests changing §1610.2(j), *Long dimension* definition to “the 150mm (6 inch) length of test specimen (cut with the 6” dimension in the same orientation of the worst burning direction of the overall fabric)”.

Response: Staff disagrees because the long dimension is not always in the fastest burning direction of the fabric. For example, when preparing preliminary test specimens to determine the fastest burning direction of a plain surface textile fabric, the 6 inch length of each specimen will be in a different fabric direction.

Comment: Two commenters (#s 4 and 6) request clarification of the definition of a base burn as well as specifying methods for identifying a base burn.

Response: Staff feels the definition at §1610.2(a), *Base burn* is sufficient and clearly defines base burn. The definition also includes specific burning characteristics that must be observed during and after each test in order to distinguish between a base burn starting at the point of impingement and the type of base burn used to establish a Class 3 fabric, where the base fabric starts burning at places other than the point of flame impingement as a result of the surface flash.

Comment: One commenter (# 6) wants to know why “translucent” was not included in the definition for film.

Response: Staff acknowledges that “translucent” was inadvertently left out of the definition for film at §1610.2(d) in the proposed rule. The definition should read “*Film means any non-rigid, unsupported plastic, rubber or other synthetic or natural film or sheeting subject to the Act, or any combination thereof, including transparent, translucent and opaque material, whether plain, embossed, molded or otherwise surface treated, which is in a form or state ready for use in wearing apparel, and shall include film or sheeting of any thickness*”.

COMMENT ABOUT REQUIREMENTS FOR CLASSIFYING TEXTILES

Comment: One commenter (# 3) suggests clarifying the criterion for classifying raised surface textile fabrics as Class 3, as well as clarifying that burning characteristics such as *point of impingement burns* and *surface flash only* are not sufficient criteria to reject a fabric.

Response: Staff agrees that additional text needs to be added to the proposed rule emphasizing the criterion for Class 3 failure for a raised fiber surface textile fabric. In §1610.4(c)(2), *Requirements for classifying textiles, Class 3, Rapid and Intense Burning, Raised surface textile fabric*, the last sentence should be changed to “*Such textiles in their original state and /or after refurbishing as described in §1610.6(a) and §1610.6(b), when tested as described in §1610.6, shall be classified as Class 3 Rapid and Intense Burning when the time of flame spread is less than 4 seconds, and the base fabric starts burning at places other than the point of impingement as a result of the surface flash (Test result code SFBB)*”.

COMMENTS REGARDING TEST APPARATUS AND MATERIALS

Comment: Another commenter (# 4) suggests specifying requirements for the stop thread supply.

Response: Staff believes the stop thread supply is appropriately described at §1610.5(a)(2)(ii) of the proposed rule.

Comment: The commenter (# 6) is concerned there is no mention in the standard of using specimen holding racks to support the specimen holders while conditioning the specimens in the oven and desiccator.

Response: The proposed rule does not preclude the use of specimen holding racks to support the specimen holders during the conditioning period, in order to maximize space in ovens and desiccators. The CPSC staff’s Laboratory Test Manual¹ describes the specimen holding rack the CPSC laboratory staff uses.

¹ U.S. CPSC Engineering Laboratory Test Manual for Compliance Testing of General Wearing Apparel, May 1981.

COMMENTS CONCERNING THE TEST PROCEDURE

Commenter: The commenter (# 6) feels that the procedure for selecting test specimens in §1610.6(a)(3)(i), *Raised surface textile fabrics – (i) Preliminary trials* is confusing.

Response: This comment is similar to one received in response to the Advanced Notice of Proposed Rulemaking (ANPR) published September 12, 2002 concerning preliminary tests for raised fiber surface textile fabrics. As stated in the staff response², for raised fiber surface textile fabrics the standard requires the direction of the lay of the surface fibers be parallel with the long dimension of the specimen. Selecting specimens in this manner allows for the brushing procedure to raise the surface fibers, since the specimen is brushed against the direction of the lay of the surface fibers. The standard requires tests of the most flammable surface of the fabric. With many raised fiber surface textile fabrics it is easy to determine the direction of the lay of the surface fibers by touch and visual observation, and preliminary tests are not needed. However, with some fabrics it may be difficult to visually determine the correct direction of the lay of the raised surface fibers. In those cases preliminary tests should be done to determine the direction with the fastest burn time. The text in the proposed rule incorporates much of this same language, and staff feels it adequately clarifies the steps required to select the surface or direction of a raised surface textile fabric to test.

Comment: The commenter (# 6) wants to know if there is a specified rate when brushing raised fiber surface textile fabrics.

Response: The proposed rule states at §1610.6(a)(3)(iv), “The carriage shall be drawn forward by hand once against the lay of the surface fibers at a uniform rate”. Staff notes this statement is the same as specified in the current standard.

Comment: Another commenter (# 1) suggests extending the specimen size to 2 inches by 6.5 inches. The commenter is concerned about the ignition flame burning down and edge-igniting the specimen, after which the flame may travel on the back of the specimen rather than the front.

Response: This situation is addressed in the CPSC staff’s Laboratory Test Manual¹. The test manual currently suggests preparing specimens to allow anywhere from a 1/8 inch to 1/2 inch overhang in the lengthwise direction of the specimen beyond the lower edges of the specimen holder base (or bottom) plate. Positioning the specimen in the holder this way will increase the distance between the point of flame impingement and the specimen edge, thus preventing the likelihood of edge ignition, particularly if the fabric shrinks in the flame and draws up the edge. Edge ignition is caused by the ignition flame burning down and edge-igniting the fabric, after which the flame may travel up the underside of the specimen. Timed edge ignition of any specimen causes a retest.

² Memorandum from Gail Stafford, LSE, and Weiyang Tao, LSE, to Patricia Adair, ES, *Response to Comments Received as a Result of the Advanced Notice of Proposed Rulemaking (ANPR) for Updating the Standard for the Flammability of Clothing Textiles*, November 21, 2006, U.S. Consumer Product Safety Commission.

COMMENT REGARDING THE CONDITIONING PROCEDURE

Comment: One commenter (# 5) suggests cotton fabrics be tested under “real world” conditions, as specified in the International Organization for Standardization (ISO) standards 6940/6941, rather than the more severe conditions prescribed in the proposed rule.

Response: The proposed rule specifies that all specimens are placed in an oven, dried for 30 ± 2 minutes at $105^\circ \pm 3^\circ \text{C}$ ($221^\circ \pm 5^\circ \text{F}$), removed from the oven and placed over a bed of anhydrous silica gel desiccant in a desiccator until cool, but not less than 15 minutes.

Staff recognizes that cotton fibers are hygroscopic and respond quickly to changes in humidity. However, staff believes that testing cotton under the atmospheric conditions in the proposed rule will provide a greater level of safety than testing under standard atmospheric conditions for textile testing. Staff also notes that the conditions in the proposed rule are the same as those in the current standard.

COMMENTS CONCERNING THE LAUNDERING METHOD

Comment: Two commenters (#s 6 and 8) suggest that since the American Association of Textile Chemists and Colorists (AATCC) Test Method 124 “*Appearance of Fabrics After Repeated Home Laundering*” was recently updated, the latest version should be referenced in the proposed rule.

Response: Staff agrees the proposed rule should reference AATCC 124-2006 (instead of AATCC 124-2001).

Comment: The same two commenters (#s 6 and 8) recommend a warm water wash of $41^\circ \pm 3^\circ \text{C}$ ($105^\circ \pm 5^\circ \text{F}$) rather than the hot water wash of $60^\circ \pm 3^\circ \text{C}$ ($149^\circ \pm 5^\circ \text{F}$) as stated in the proposed rule.

Response: Staff notes the wash water temperature as stated at §1610.6(b)(ii) *Laundering procedure* in the proposed rule contains a typographical error. The water temperature of $149^\circ \pm 5^\circ \text{F}$ is incorrect and should have been stated as $140^\circ \pm 5^\circ \text{F}$.

In response to the comment, the staff’s intent is to harmonize the laundering provisions in 16 CFR Part 1610 with the other Flammable Fabrics Act (FFA) regulations. The current standard specifies a hand washing procedure using wash water of 95° to 100°F (35° to 38°C). However, staff agrees with the commenters that the hot water wash specified in the proposed rule could change the fabric structure of many fabrics, such as silks and rayons, and thus affect the flammability of the fabric. It is noted that ASTM D1230, “*Standard Test Method for Flammability of Apparel Textiles*” section 9.2.2 specifies that “*If no care instructions are given, machine wash warm (120°)*”. Based on this information, the proposed rule should specify in §1610.6(b)(ii) *Laundering procedure*, AATCC 124-2006 using wash water temperature (IV) $49 \pm 3^\circ \text{C}$ ($120^\circ \pm 5^\circ \text{F}$) specified in Table II of that method. All of the other washing and drying conditions will remain as currently stated in the proposed rule and be consistent with the other

FFA regulations (16 CFR Parts 1615, 1616, 1630, 1631 and 1632). An earlier version of this test method (AATCC 124-96) was incorporated by reference in the other FFA standards in 2000³. The laundering and tumble drying options in AATCC Test Method 124 versions 1996, 2001 and 2006 are identical.

Comment: The commenter (# 4) suggests the “*maximum washing load: 8 lb.*” be removed and only a washing ratio be required.

Response: The maximum wash load weight specified in the proposed rule is identical to the maximum wash load weight of 3.64 kg (8 lb.) consisting of any combination of test specimens and dummy pieces (ballast) currently specified in the laundering provisions of the other FFA regulations (16 CFR Parts 1615, 1616, 1630, 1631 and 1632).

Comment: The same commenter (# 4) recommends natural drying.

Response: The proposed rule specifies tumble drying. Tumble drying was not widely available to American consumers when the standard was originally written. According to the American Home Appliance Manufacturer’s (AHAM) “*2006 Saturation & Marketing Factors Study*” by The Stevenson Company, 81.1% of US households have a clothes dryer, so natural or line drying would not reflect consumer care practice in the United States.⁴

COMMENTS REGARDING THE DRY CLEANING PROCEDURE

Comment: One commenter (# 4) recommends adopting a “trial dry cleaner” in accordance with the ISO standards, but does not specify which ISO standard(s).

Response: As was discussed in the NPR, the dry cleaning procedure in the proposed rule is similar but not identical to ASTM D1230 “*Standard Test Method for Flammability of Apparel Textiles section 9.2.1.6 Option B*”. The ASTM D1230 procedure was found to be as stringent as the procedure specified in 16 CFR Part 1610.⁵ Staff does not have any data to indicate whether use of a “trial dry cleaner” would be as stringent as the refurbishing procedure in ASTM D1230.

Comment: Another commenter (# 6) suggests the proposed rule indicate how much detergent is to be used in the dry cleaning procedure.

Response: The amount of detergent used will depend on the size/capacity of the commercial dry cleaning machine. Manufacturer operating instructions should provide this information.

Comment: Two commenters (#s 6 and 8) question why §1610.6(b)(1)(i)(B) of the proposed rule requires that samples be dry cleaned in a load that is 80% of the dry cleaning machine’s

³ 65 *Federal Register* 12935; 65 *Federal Register* 12929; 65 *Federal Register* 12924. March 10, 2000.

⁴ AHAM 2006 report on laundry appliances.

⁵ Letter to Don Knodel, Chairman of the ASTM Subcommittee D13.52 Flammability, from Linda Fansler, ES, June 1993.

capacity. They think this is not an efficient use of the machine and suggest the load should be 100% of the machine's capacity.

Response: The International Fabricare Institute (IFI) recommends that most items should be dry cleaned in a load that is 80% of the machine's capacity. IFI feels most loads should be done this way even if a dummy load is required.⁶

Comment: Three commenters (#s 3, 6 and 8) ask why the proposed rule specifies ballast using a combination of 80% wool fabric pieces and 20% polyester fabric pieces. They want to know why the ballast can't consist of only cotton fabric pieces or cotton/polyester blended fabric pieces, instead of the combination of wool and polyester fabrics.

Response: Under further consideration, staff believes the ballast specified in §1610.6(b)(1)(i)(B) should be a combination of 80% wool fabric pieces and 20% cotton fabric pieces. In AATCC Test Method 158, "*Dimensional Changes on Drycleaning in Perchloroethylene Machine Method*", Section 6.4 specifies "Ballast consisting of clean textile pieces or garments. These shall be white or a light color and consist of about 80% wool and 20% cotton or rayon."⁷ The ISO standard 3175 for dry cleaning fabrics and garments also has an option to use a combination of 80% wool fabric pieces and 20% cotton fabric pieces⁷. Staff thinks that ballast containing 80% wool and 20% cotton is a reasonable choice because it is consistent with both the AATCC and ISO standards. Test results would be more consistent and comparable if all testing labs use the same ballast of 80% wool and 20% cotton (no rayon option). In addition, staff thinks any ballast to be used in the dry cleaning procedure should not affect the 16 CFR Part 1610 test results. Wool is a naturally flame resistant fiber, and any lint that wool would give off and deposit on samples should not increase the flammability of the fabric samples. However, too much wool lint deposited on the test samples might decrease their flammability; but adding a small percentage of cotton fabric to the ballast could counterbalance the effect of too much wool lint deposit. This reasoning is based on the idea that the flammable cotton lint produced by the cotton fabric pieces and deposited on the test samples could increase the flammability of the samples. The same reasoning also explains that ballast consisting of either all cotton fabric pieces or cotton/polyester blended fabric pieces is not a good choice. In either of these cases the only lint produced by the ballast in the dry cleaning load would be cotton.

COMMENT ABOUT THE TEST SEQUENCE

Comment: One commenter (# 6) suggests the language in the proposed rule for "*Test sequence and classification criteria for plain surface textile fabric*" should read the same for both the "*as received or original state*" and "*after refurbishing*" conditions.

Response: Staff agrees with the commenter that the language should be the same. For consistency paragraph (C) in both §1610.7(b)(1) *Step 1, Plain surface textile fabrics in the "as received" or original state* and §1610.7(b)(2) *Step 2, Plain surface textile fabrics after*

⁶ Email to Patricia Adair, CPSC, from Brian Johnson, International Fabricare Institute, June 20, 2006.

⁷ Email to Patricia Adair, CPSC, from Amy Hammonds, AATCC, June 12, 2006.

refurbishing should read: *“The average burn time of two or more specimens is equal to or greater than 3.5 seconds”*.

TAB E



UNITED STATES
CONSUMER PRODUCT SAFETY COMMISSION
WASHINGTON, DC 20207

Memorandum

Date: November 16, 2007

TO : Patricia K. Adair, Project Manager
Directorate for Engineering Sciences

THROUGH: Hugh McLaurin, Associate Executive Director *Hmm*
Directorate for Engineering Sciences
Mark Kumagai, Director *Mark Kumagai*
Division of Mechanical Engineering

FROM : John R. Murphy *Mark Kumagai for JRM*
Mechanical Engineer

SUBJECT : Response to Comments Received as a Result of the Notice of Proposed
Rulemaking (NPR) for Updating the *Standard for the Flammability of Clothing
Textiles*

The Directorate for Engineering Sciences, Division of Mechanical Engineering (ESME), was asked to address several issues identified in the comments received on the NPR¹ to update the *Standard for the Flammability of Clothing Textiles* (16 C.F.R. Part 1610). This memorandum summarizes the issues identified and presents the staff's responses to them. The comments are in regard to the test equipment described in the proposed amendments to the standard.

COMMENTS REGARDING THE FLAMMABILITY TEST CABINET

Comment: Two commenters (#s 2 and 7) stated that the proposed rule adequately describes the parameters of a modern flammability test apparatus. Another commenter (#6) suggested changes to the description and figures. This comment included adding tolerances to the measurements given for the test cabinet and parts.

Response: The staff agrees with the comment (#6) and has added tolerances where appropriate.

Comment: One commenter (#6) asked about the number of holes in the rear of the top closure of the test cabinet. The current version of the regulation indicated 12 holes and the proposed amendment indicates 11 holes. The commenter is concerned that test cabinets currently in use that have 12 holes will no longer meet the standard.

Response: The metal test chamber prevents air circulation around the specimen rack and flame, but permits free ventilation for rapid oxidation. The current requirements in 16 C.F.R.

¹ 72 Federal Register 8844, "16 C.F.R. Part 1610 Standard for the Flammability of Clothing Textiles: Proposed Rule," February 27, 2007.

1610.4(b)(1) describe the test chamber as having “twelve, 0.5” holes equidistant along the rear of the top enclosure. The proposed rule describes the chamber as having 11 holes. All of the CPSC test cabinets, purchased over the years from U.S. Testing Co., have eleven, 0.4 holes along the rear of the top enclosure. The lack of one hole which is for ventilation purposes only will make little or no difference in the final test result.² Test cabinets with 12 holes in the rear top enclosure will still meet the standard.

Comment: One commenter (#6) suggested adding specifications for the indicator finger and protective shield.

Response: The staff agrees with the comment. Two figures have been added showing an example of a typical indicator finger and protective shield.

Comment: One commenter (#6) suggested that section 1610.5(2)(iii) should contain a reference to Figure 1.

Response: Staff agrees and has added a reference to Figure 1 in section 1610.5(2)(iii).

COMMENTS REGARDING THE TEMPLATE

Comment: One commenter (#4) suggested that the template for the brushing device (§1610.5(10)) be “above 3.2 mm (0.13 in) thick.” The proposed amendment reads “The template shall be 3.2 mm (0.13 in) thick.”

Response: The current standard indicates that the template shall be at least 1/8 inch thick. The staff proposes to revise the amendment to 0.32 cm (0.125 in) ± 0.05 cm [0.019 in] to reflect 1/8 inch.

² U.S. CPSC Memorandum from Jean C. Williams, ESEL, to Robert G. Poth, CARM, “Justification for Laboratory Procedural Changes,” June 9, 1981.

TAB F



UNITED STATES
CONSUMER PRODUCT SAFETY COMMISSION
WASHINGTON, DC 20207

Memorandum

Date: JAN - 3 2008

TO : Patricia K. Adair, Project Manager
Directorate for Engineering Sciences

THROUGH: John G. Mullan, Director *JGM*
Office of Compliance and Field Operations

FROM : Mary Toro, Associate Director *MT*
Chemical, Clothing, Household & Tools Products

SUBJECT : Response to Comments Received as a Result of the Notice of Proposed
Rulemaking (NPR) for Updating the *Standard for the Flammability of Clothing
Textiles*

The Office of Compliance and Field Operations (CE) was asked to address several issues identified in the comments received on the NPR¹ to update the *Standard for the Flammability of Clothing Textiles* (16 C.F.R Part 1610). This memorandum summarizes the issues identified and presents the CE responses to them.

Several comments received in response to the NPR were already addressed in the November 30, 2006 briefing package to the Commission². These included adding a list of "suspect fabrics" to the standard, updating the current number of recalls, exempting leather and specialty wool fibers and testing narrow fabrics.

COMMENTS REGARDING EXEMPTIONS

Comment: One commenter (#4) requested that the Commission provide the basis for the 2.6 oz/yd² exemption for all plain surface fabrics and asked for the historical information that formed the basis for the exemption. The commenter further requested that, if that information could not be provided, the exemption be lowered to 2.0 oz/yd².

Response: On December 14, 1984, the Commission promulgated final amendments to 16 C.F.R. Part 1610 which prescribed requirements for testing to support guaranties of products,

¹ 72 Federal Register 8844, "16 C.F.R. Part 1610 Standard for the Flammability of Clothing Textiles: Proposed Rule", February 27, 2007.

² Briefing Package. Project to Update/Amend the Flammability Standard for Clothing Textiles, 16 C.F.R. Part 1610. November 30, 2006. <http://www.cpsc.gov/LIBRARY/FOIA/FOIA07/brief/FlammStdsClothingTextile s.pdf-1711.5KB>

fabrics, and related materials subject to the standard.³ These amendments included an exemption for all plain surface fabrics weighing 2.6 oz/yd², regardless of fiber content.

COMMENTS REGARDING SPECIFIC APPAREL ITEMS

Comment: One commenter (#4) suggested the Commission clarify in the proposed amendments that the standard does not apply to scarves.

Response: The proposed amendment, like the current 16 C.F.R. Part 1610, applies to scarves.

COMMENTS REGARDING REASONABLE AND REPRESENTATIVE TESTING

Comment: One commenter (#3) requested guidance as to the number of tests to perform per lot size.

Response: The regulation allows manufacturers to develop a testing program that is appropriate for their circumstances. *Subpart C – Interpretations and Policies*, §1610.61 of the proposed amendment, provides information on reasonable and representative testing. In addition, guidance on developing a reasonable and representative testing program can be found at 63 *Federal Register* 154, August 11, 1998; *Policy Statement – Reasonable and Representative Testing to Assure Compliance with the Standard for the Flammability of Clothing Textiles*.

³ 49 *Federal Register* 242; December 14, 1984. 16 C.F.R. Part 1610 *Standard for the Flammability of Clothing Textiles*; Requirements for Testing and Recordkeeping to Support Guaranties.

TAB G



UNITED STATES
CONSUMER PRODUCT SAFETY COMMISSION
WASHINGTON, DC 20207

Memorandum

Date: August 6, 2007

TO : Patricia K. Adair, Project Manager, ESFS

THROUGH: Gregory B. Rodgers, Ph.D. Associate Executive Director, Economic Analysis *GBR*

Deborah V. Aiken, Ph.D., Senior Staff Coordinator *DVA*

FROM : Dale R. Ray, Directorate for Economic Analysis *DRR*

SUBJECT : Final Regulatory Analyses --- Clothing Textiles Standard Amendment

Attached is a consolidated Directorate for Economic Analysis (EC) report presenting a final regulatory analysis, final regulatory flexibility analysis and environmental review of technical amendments to the Commission's Standard for Clothing Textiles, 16 CFR 1610. The Commission proposed these amendments in February 2007. The EC report provides information related to required findings under each of the three applicable statutes: the Flammable Fabrics Act, the Regulatory Flexibility Act and the National Environmental Policy Act.

Attachment



**Final Regulatory Analysis
Of Amendments to the
Flammability Standard for Clothing Textiles
(16 CFR 1610)**

Dale R. Ray
Terrance R. Karels
Directorate for Economic Analysis
U.S. Consumer Product Safety Commission

August 2007

Table of Contents

	<u>Page</u>
Executive Summary.....	3
Regulatory Analysis.....	4
Background.....	4
Potential Benefits and Costs.....	5
Regulatory Alternatives.....	6
Public Comments.....	7
Regulatory Flexibility Analysis.....	8
Environmental Review.....	8
Conclusions.....	9

Executive Summary

On February 27, 2007, the U.S. Consumer Product Safety Commission (CPSC) published a notice of proposed rulemaking (NPR) proposing technical amendments to the Standard for the Flammability of Clothing Textiles, 16 CFR Part 1610. This standard, also known as the General Wearing Apparel Standard, was originally issued as a part of the Flammable Fabrics Act (FFA) of 1953, was amended by the Department of Commerce (DOC) and adopted by CPSC in 1975. The 2007 proposed amendments would revise and clarify the definitions in the standard, revise the standard's laundering and dry-cleaning test methods, and specify modern test apparatus, to reflect current technologies, safe laboratory practices and consumer care practices. The proposed revisions incorporated suggestions from public comments submitted to the Commission in response to the agency's September 2002 advance notice of proposed rulemaking.

The proposed technical amendments would, if issued on a final basis, maintain current industry practice, and would not significantly affect the benefits or costs associated with the standard. The Commission received eight public comments that generally supported the proposal, and presented a number of technical recommendations; none raised economic or environmental issues. The CPSC staff agreed with some of these recommendations and made minor changes to the proposed amendments. Some commenters suggested changes in the overall scope of the standard; these were not considered to be relevant to this rulemaking proceeding. No substantive changes to the preliminary regulatory analysis were made as a result of the public comments.

The amendments would have no significant impact on small firms subject to the standard or on other small entities, and there would be no significant environmental impacts. Further, no reasonable regulatory alternatives have been identified that would make the standard more effective or less costly.

Introduction

On February 27, 2007, the U.S. Consumer Product Safety Commission (CPSC) proposed technical amendments to the flammability standard for clothing textiles, 16 CFR Part 1610. This standard was originally issued under the Flammable Fabrics Act (FFA) by the Department of Commerce in 1953, and codified by CPSC in 1975. The standard regulates articles of clothing and fabrics and other materials intended to be used in clothing, whether for children or adults (additional requirements for children's sleepwear, at 16 CFR Parts 1615 and 1616, are not affected by the proposed amendments). The proposed amendments would modify:

- some definitions in the standard,
- specifications for the flammability test equipment,
- fabric refurbishing methods,
- testing and conditioning procedures,
- test result interpretations, and
- the written structure of the standard itself.

The proposed amendments would not affect the flammability requirements for apparel, but rather would revise several outdated provisions of the standard and better reflect current consumer practices and modern technology.

Requirements of Applicable Statutes

The FFA requires that the Commission prepare a final regulatory analysis of any final regulation. The analysis must contain:

- a description of the potential benefits and potential costs of the regulation, including costs and benefits that cannot be quantified in monetary terms, and the identification of those likely to receive the benefits and bear the costs;

- a description of any alternatives to the final regulation which were considered by the Commission, together with a summary description of their potential benefits and costs and brief explanation of the reasons why these alternatives were not chosen; and
- a summary of any significant issues raised by the comments submitted during the public comment period in response to the preliminary regulatory analysis, and a summary of the assessment by the Commission of such issues.

In this case, the Commission must find that:

- The benefits expected from the amendments bear a reasonable relation to its costs; and
- The amendments impose the least burdensome requirement which prevents or adequately reduces the risk of injury.

Additionally, under the Regulatory Flexibility Act of 1980 (RFA), the Commission is required to address potential effects of the amendment on small businesses and other small entities. Further, under the National Environmental Policy Act (NEPA), the Commission is required to consider the potential environmental impacts of the amendments. This report presents an analysis of potential impacts in accordance with all three of the applicable statutes: the FFA, RFA and NEPA.

Potential Benefits and Costs

The clothing textiles standard provides a minimum level of fire protection for articles of apparel worn by consumers. The amendments under consideration pertain to definitions and test methods, and are technical in nature. The amendments would not affect the substance or likely results of the performance tests in the standard; the projected effectiveness of the standard would neither

increase nor decrease as a result. Thus, there would be no impact on the level or value of fire safety benefits (i.e., the reduced risk to the public of fire-related death, injury, or property damage) derived from the standard.

The amendments to the standard are not expected to increase costs to manufacturers and importers of products that currently comply. These firms have, for a number of years, been conducting compliance tests using methods and apparatus that would be allowed under the amendments. Overall, the amendments, if issued on a final basis, would not likely have any significant impact on apparel and fabric testing costs.

On balance, the technical amendments would have no significant impact on expected benefits or costs of the flammability standards for clothing textiles. The amendments would simplify testing requirements and allow existing practices among manufacturers and importers subject to the standard.

Alternatives

There is an existing U.S. voluntary consensus standard for wearing apparel. This standard, ASTM D-1230, "Test Method for Flammability of Apparel Textiles," contains performance tests that are virtually identical to those in the existing FFA standard, but that are presented in a standard ASTM format with somewhat different language on some elements. The Commission could opt to use the ASTM standard language instead of the language of the proposed amendments. The language of the CPSC-proposed amendments is, however, clearer and more complete than that of the ASTM standard. The ASTM alternative would have no significant economic effects.

An existing U.S. voluntary consensus standard for clothing textile washing procedures, AATCC Test Method 124-2006, is incorporated by reference in the

proposed amended federal standard. An international standard (ISO) test method also exists for apparel dry cleaning procedures. The Commission could opt to incorporate the provisions of this international standard into the amended federal standard, but they are no more clear or comprehensive than CPSC's proposed amendments. Again, this alternative would have no significant economic effects.

In summary, there are no readily available and technically feasible alternatives that would be significantly different from the Commission's proposed amendments. Thus, no reasonable alternative would make the standard more effective or less costly.

Public Comments

The Commission's February 27, 2007 *Federal Register* notice solicited public comment on the agency's proposed amendments. CPSC received eight submissions from individuals and organizations representing manufacturers, importers, retailers and testing laboratories. The commenters presented a number of technical recommendations on the details of the proposed amendments. The CPSC staff agreed with some of these recommendations and made some changes in the amendments. These relatively minor changes have no impact on the expected benefits and costs of the standard. In addition, some commenters recommended changes in the basic scope of the standard, i.e., revisions in the applicability of the standard to certain classes of fabrics and materials. As noted in the Commission's September 2002 advance notice of proposed rulemaking (ANPR), the scope of the rulemaking proceeding is limited to improvements reflecting consumer practices and modernized test equipment, and to clarifications of several technical elements of the standard. CPSC could initiate a separate proceeding to consider these more substantive kinds of scope issues if the Commission determined that such changes may be necessary. The

comments on the technical amendments generally supported the conclusions stated in the preliminary regulatory analysis.

Final Regulatory Flexibility Analysis

The RFA requires that the Commission consider whether a rule would have a significant effect on a substantial number of small entities, including small businesses and small government entities. In the NPR, the Commission certified that the proposed amendments would not have a significant economic impact on a substantial number of small entities. The amendments would keep current industry practices and procedures in place, while providing clarification on several technical elements of the standard. No additional actions would be required of small entities.

Based on available information, including public comments submitted in response to the NPR, there would be little or no effect of the technical amendments on small producers or importers of wearing apparel, since the standard already requires that such products meet the criteria of the tests and the tests would remain unchanged. Consequently, the Commission could conclude that issuing the amendments on a final basis would have no expected economic consequences on a substantial number of small entities.

Environmental Review

Under NEPA, the Commission must consider potential environmental impacts associated with the technical amendments. The amendments would allow industry to continue its current practices, and would impose no new requirements. The Commission received no public comments on environmental issues.

The technical amendments are not expected to have an impact on the production processes developed by manufacturers. Also, there is no expected impact on the amounts of materials used in manufacture, packaging or labeling. The amendments would not render existing finished goods inventories, or works in progress, unusable. Thus, there would likely be no environmental impacts on air or water quality or other aspects of the environment if the amendments were issued on a final basis.

Conclusions

If the Commission promulgated the proposed technical amendments to the flammability standard for clothing textiles:

- The current industry testing and other procedures would continue without interruption;
- The effectiveness of the standard would be unaffected, and testing costs to manufacturers and importers would not increase; the net impact on benefits and costs would be negligible;
- No reasonable regulatory alternatives to the testing and procedural amendments would further reduce testing costs;
- There would be no significant impacts on small firms or other small entities; and
- There would likely be no significant environmental impacts.