



United States  
**CONSUMER PRODUCT SAFETY COMMISSION**  
4330 East-West Highway  
Bethesda, Maryland, 20814

**MEMORANDUM**

**DATE: May 22, 2008**

**TO :** EC

**Through:** Todd A. Stevenson, Secretary, OS 

**FROM :** Martha A. Kosh, OS 

**SUBJECT:** Standard for the Flammability of Residential Upholstered Furniture

ATTACHED ARE COMMENTS ON THE CF 08-1

<u>COMMENT</u>	<u>DATE</u>	<u>SIGNED BY</u>	<u>AFFILIATION</u>
CF 08-1-1	4/14/08	John C. Dean President	National Association of State Fire Marshals 1319 F St, NW, Suite 301 Washington, DC 20004
CF 08-1-2	4/14/08	William Schecter Professor of Clinical Surgery Chief of Surgery	University of California San Francisco San Francisco General Hospital Box 0807 San Francisco, CA 94143
CF 08-1-3	4/18/08	Robert Rita State Rep.	Illinois House of Representatives 28 <sup>th</sup> District 247-E Stratton Building Springfield, IL 62706
CF 08-1-4 <b>Rec'd 4/22/08</b>	4/15/08	Mark Biel Exec. Director	Chemical Industry Council of Illinois 2250 E. Devon Avenue Suite 239 Des Plaines, IL 60018
CF 08-1-5	4/21/08	Robert Tardy	Somerset Associates P.O. Box 336 Newport, ME 04953

**Standard for the Flammability of Residential Upholstered Furniture**

CF 08-1-6	4/24/08	Cameron Smyth Assemblyman	Assembly California Legislature 38 <sup>th</sup> District State Capitol P.O. Box 942849 Sacramento, CA 94249
CF 08-1-7	4/29/08	Mark Denzler Vice President Government Affairs and Membership	Illinois Manufacturers Association 220 East Adams St. Springfield, IL 62701
CF 08-1-8	4/29/08	Michael Egenton Vice President	New Jersey Chamber of Commerce 216 West State St. Trenton, NJ 08608
CF 08-1-9	4/30/08	Kevin Jeffries Assemblyman	California State Assembly 66 <sup>th</sup> District Capitol Office, Rm 5128 Sacramento, CA 94249
CF 08-1-10	5/01/08	Members of CA State Legislature	California Legislature State Capitol, P.O. Box 942849 Sacramento, CA 94249
CF 08-1-11	5/02/08	Chris Smith Director of Governmental Affairs, CAN	Coats North America 3430 Toringdon Way Suite 301 Charlotte, NC 28277
CF 08-1-12	5/02/08	Ladson Fraser Research and Development - Nonwoven Products	Precision Fabrics Group Greensbor Finishing Plant 301 East Meadowview Rd. Greensboro, NC 27420
CF 08-1-13	5/05/08	Blair Schrader	E.J. Schrader Co., Inc.
CF 08-1-14 CF 08-1-14A	5/05/08	Karl Spilhaus President	National Textile Assoc. 6 Beacon Street Suite 1125 Boston, MA 02108
CF 08-1-15	5/05/08	Steve DeHann Executive Vice President	National Home Furnishings Association <a href="mailto:mbolek@nhfa.org">mbolek@nhfa.org</a>

**Standard for the Flammability of Residential Upholstered Furniture**

CF 08-1-16	5/05/08	Timothy Coyle Sr. Vice	California Building Industry Association 1215 K St, Suite 1200 Sacramento, CA 95814
CF 08-1-17	5/05/08	Jason Schmelzer Policy Advocate	California Chamber of Commerce 1215 K St, Suite 1400 Sacramento, CA 95814
CF 08-1-18	5/06/08	Bill Simmons	Baker Furniture Company <u>Bill.simmons@Kohler.com</u>
CF 08-1-19	5/06/08	Gordon Damant	Gordon H. Damant Damant and Associates 3550 Watt Ave., Suite 5 Sacramento, CA 95821
CF 08-1-20	5/06/08	M. M. Hirschler	GBH International 2 Friars Lane Mill Valley, CA 94941
CF 08-1-21	5/06/08	P.J. Verschoore State Rep	State of Illinois 72 <sup>nd</sup> District 250 W Stratton Building Springfield, IL 62706
CF 08-1-22	5/07/08	Daniel Sprague Selectman	Town of Palmyra P.O. Box 6 Palmyra, ME 04965
CF 08-1-23	5/08/08	Ley Richardson Sr. Research Engineer	DuPont Advanced Fibers Systems P.O. Box 27001 Richmond, VA 23261
CF 08-1-24	5/08/08	Mark Buczek	<u>buczekm@aol.com</u>
CF 08-1-25	5/08/08	Delores Lekowski	<u>dlekowski@neo.rr.com</u>
CF 08-1-26	5/09/08	Michael Horowitz	<u>Mhorowitz@dir.ca.gov</u>
CF 08-1-27	5/09/08	Irwin Gasner President	Wearbest Sil-Tex Mills,ltd 325 Midland Ave. Garfield, NJ 07026
CF 08-1-28	5/11/08	S. Patterson	Box 2487 Anchorage, AK 99510
CF 08-1-29	5/11/08	Robert Barish	3056 Castro Valley Blvd #49 Castro Valley, CA 94546

**Standard for the Flammability of Residential Upholstered Furniture**

CF 08-1-30	5/12/08	Nancy McNabb Director, Government Affairs	National Fire Protection Association 1401 K St, NW, Suite 500 Washington, DC 20005
CF 08-1-31	5/12/08	Jeff Turner	Praxishr 701 Fifth Ave, Suite 4200 Seattle, WA 98104
CF 08-1-32	5/12/08	Mary Brune Co-Founder & Director	Making Our Milk Safe 1516 Oak St, Suite 320 Alameda, CA 94501
CF 08-1-33	5/13/08	Steve Gibbs	1802 30 <sup>th</sup> Avenue, South Seattle, WA 98144
CF 08-1-34	5/13/08	Nate Peery	621 5 <sup>th</sup> Ave. N, #404 Seattle, WA 98109
CF 08-1-35	5/13/08	Robert Foster Attorney and Counselor	Foster Law Firm, LLP 601 East McBee Ave Suite 104 Greenville, SC 29602
CF 08-1-36	5/13/08	Judy Levin, MSW Pollution Prevention Coordinator	Center for Environmental Health 528 61 <sup>st</sup> St., Suite A Oakland, CA 94609
CF 08-1-37	5/13/08	Linwood Rayford Asst. Chief Counsel for Food, Drug and Health Policy	SBA Office of Avocacy 409 Third St, SW Washington, DC 20416
CF 08-1-38	5/14/08	P. Hirschler	76-12 35 <sup>th</sup> Ave, Apart. SE New York, NY 11372
CF 08-1-39	5/14/08	Gwen Norton <b>Ltr dated 4/14/08</b>	4301 Garfield St. Anchorage, Alaska 99503
CF 08-1-40	5/14/08	Stacy Sikora	403 W. Howe Seattle, WA 98119
CF 08-1-41	5/15/08	J. Zicherman Ph.D, SFPE	Fire Cause Analysis 935 Pardee Street Berkeley, CA 94710
CF 08-1-42	5/15/08	Vince Diaz President	Atlantic Thread and Supply Co., Inc. <a href="mailto:vdiaz@atlanticthread.com">vdiaz@atlanticthread.com</a>

---

**Standard for the Flammability of Residential Upholstered Furniture**

CF 08-1-43	5/15/08	Mary Ellen Tang	18 Equestrian Ct. Huntington, NY 11743
CF 08-1-44	5/15/08	Fred Hickey	Newport Fire Department 21 Water Street Newport, ME 04953
CF 08-1-45	5/15/08	Employees	Silent Spring Institute 29 Crafts Street Newton, MA 02458
CF 08-1-46	5/15/08	Chris Hall	P.O. Box 90234 Anchorage, AK 99509
CF 08-1-47	5/15/08	Tony Stefani	San Francisco Firefighters Cancer Prevention Foundation <a href="mailto:sffcpf@sbcglobal.net">sffcpf@sbcglobal.net</a>
CF 08-1-48	5/16/08	Laura Zuniga Chief	Bureau of Home Furnishings and Thermal Insulation 3485 Orange Grove Ave. Suite A North Highlands, CA 95660
CF 08-1-49	5/16/08	Bobby Bush Vice President Foam & Environ- mental Tech.	Hickory Springs Manufacturing Company <a href="mailto:bwbush@hickorysprings.com">bwbush@hickorysprings.com</a>
CF 08-1-50	5/16/08	J. Chapin, Ph.D Director Research and Development	Underwriters Laboratories 333 Pfingsten Road Northbrook, IL 60062
CF 08-1-51	5/16/08	Dennis Huang Exec. Director	Asian Business Association
CF 08-1-52	5/16/08	Sherri Mesch	<a href="mailto:sherri-m@hotmail.com">sherri-m@hotmail.com</a>
CF 08-1-53	5/16/08	H. Gundavaram	80 West Cedar St, #1 Boston, MA 02114
CF 08-1-54	5/16/08	Bob Raymond Vice President Sales and Marketing	ICL-IP America 420 Saw Mill River Rd. Ardsley, NY 10502
CF 08-1-55	5/16/08	Mike Rogge Policy Director Environmental Quality	California Manufacturers & Technology Assoc. 1115 Eleventh St. Sacramento, CA 95814

---

**Standard for the Flammability of Residential Upholstered Furniture**

CF 08-1-56	5/16/08	Barbara McQuiddy	9501 E. Broadway Rd, #73 Mesa, AZ 85208
CF 08-1-57	5/16/08	Shannon Reed	Albemarle Corporation 451 Florida St. Baton Rouge, LA 70801
CF 08-1-58	5/17/08	David Borowski Exec. Director	Flicker of Hope Foundation 8624 Janet Lane Vienna, VA 22180
CF 08-1-59	5/17/08	Joan Blades Co-founder and President	Moms Rising <a href="mailto:joan@moveon.org">joan@moveon.org</a>
CF 08-1-60	5/17/08	Mary M. McNamara	The Upholstered Furniture Action Council 6094 Franconia Rd, Suite B Alexandria, VA 22310
CF 08-1-61	5/18/08	B. Schultheis Fire Marshal	San Francisco Fire Depart. 698 2 <sup>nd</sup> St. San Francisco, CA 94107
CF 08-1-62	5/18/08	Tony Bowman	8403 Locust Ave., Apt F1 Bonney Lake, WA 98391
CF 08-1-63	5/19/08	David Ryan Director of Quality	Craftex Mills Designing & Weaving Fine Fabrics 2100 Market St. Auburn, PA 17922
CF 08-1-64	5/19/08	Consumer	American Home Furnishings Alliance
CF 08-1-65	5/19/08	Richard Driscoll	BIFMA International <a href="mailto:rdriscoll@bifma.org">rdriscoll@bifma.org</a>
CF 08-1-66	5/19/08	Steve Russel Managing Director	American Chemistry Council 1300 Wilson Boulevard Arlington, VA 22209
CF 08-1-67	5/19/08	David Sanders Director Advocacy	Chemtura Corporation 1801 US Highway, 52 West West Lafayette, IN 47906
CF 08-1-68	5/19/08	Richard Taffet on behalf of Decorative Fabrics Assoc.	Bingham McCutchen LLP 399 Park Ave. New York, NY 10022

---

**Standard for the Flammability of Residential Upholstered Furniture**

CF 08-1-69	5/19/08	James F. Hoebel	13506 Star Flower Court Chantilly, VA 20151
CF 08-1-69	5/19/08	James F. Hoebel	13506 Star Flower Court Chantilly, VA 20151
CF 08-1-70	5/19/08	Sara Schedler Campaign Associate	Friends of Earth 311 California St. Suite 510 San Francisco, CA 94104
CF 08-1-71	5/19/08	George Booth Product Manager	Firegard Brand Products Springs Creative Products Group, LLC 220 W. White St. Rock Hill, SC 29730
CF 08-1-72	5/19/08	John C. Dean President	National Association of State Fire Marshals 1319 F St., NW, Suite 301 Washington, DC 20004
CF 08-1-73	5/19/08	S. Messina	The Govmark Organization 96 Allen Blvd, Suite D Farmingdale, NY 11735
CF 08-1-74	5/19/08	Robert Luedeka Exec. Director	Polyurethane Foam Assoc. 9724 Kingston Pike Suite 503 Knoxville, TN 37922
CF 08-1-75	5/19/08	Steve Lamar Executive Vice President	American Apparel & Footwear Association 1601 North Kent St. Suite 1200 Arlington, VA 22209
CF 08-1-76	5/19/08	D. Lauzier	Ethan Allen Global, Inc. Ethan Allen Dr. P.O. Box 1966 Danbury, CT 06813
CF 08-1-77	5/19/08	Gary Hansen Chairman	Federation of Burn Foundations c/o Burns Recovered Support Group 11710 Administration Dr. St. Louis, MO 63146
CF 08-1-78	5/19/08	Arlene Blum	<a href="mailto:arlene@arleneblum.com">arlene@arleneblum.com</a>
CF 08-1-79	5/19/08	P.J. Wakelyn	National Cotton Council Box 820285 Memphis, TN 38182

---

**Standard for the Flammability of Residential Upholstered  
Furniture**

CF 08-1-80 5/19/08 Gene Valcke Association of Woodworking  
and Furnishings Suppliers  
500 Citadel Dr.  
City of Commerce, Ca 90040

CF 08-1-81 5/19/08 S. Lewis, Jr. State of West Virginia  
**Ltr dated 5/12/08** State Fire Department of Military  
Marshal Affairs & Public Safety  
1207 Quarrier St, 2<sup>nd</sup> Fl.  
Charleston, WV 25301



**Stevenson, Todd**

---

**From:** GBHint@aol.com  
**Sent:** Tuesday, May 06, 2008 2:07 PM  
**To:** CPSC-OS  
**Cc:** Ray, Dale  
**Subject:** Upholstered Furniture NPR  
**Attachments:** GBH Comments on Uph Furn Flam May 2008.pdf

To: Office of the Secretary, Consumer Product Safety Commission

Please find attached comments by GBH International on the Upholstered Furniture NPR. A subsequent e-mail will contain the attachments

Yours sincerely

Marcelo M. Hirschler  
GBH International  
2 Friars Lane - Mill Valley - CA - 94941 - USA  
Tel: (415) 388 8278/FAX: (415) 388 5546  
e-mail: gbhint@aol.com  
e-mail: mhirschler@gbhinternational.com  
web site: www.gbhinternational.com

---

Wondering what's for Dinner Tonight? [Get new twists on family favorites at AOL Food.](#)

are highly vulnerable to open flame ignitions,<sup>2</sup> how does the CPSC plan to prevent against the distinct probability that open flame ignitions would become more frequent and more severe as a result of greater movement to fabrics that perform well in a smolder-only standard?

**Questions about the proposal's failure to protect against ignition of filling materials.**

The proposed standard lacks a provision for protection of the filling material (except in the small percentage of cases that would be considered "Type II"), which is the largest fuel load within the item of furniture itself, probably the largest fuel load within the entire room, and perhaps the largest fuel load within the entire residence. Fire safety officials advocate "layers of safety" or "safety redundancy," which is the generally accepted way of ensuring the protection of life and property, especially if one or more safety measures were to fail. This is why NASFM advocates for product safety standards in addition to smoke alarms, residential sprinklers and arc-fault circuit interrupters. This is why NASFM advocates for fire resistance of products that act as major fuel loads (such as upholstered furniture and mattresses) as well as for safety measures directed at making potential ignition sources safer (such as cigarettes, candles and lighters). And, within a piece of upholstered furniture, it is why NASFM advocates for protection against both major sources of ignition (smoldering and open flame) and of both cover and filling materials.

In the case of the CPSC proposal, the cover material of the upholstered furniture would be the only thing protecting against a major fire that would lead to room flashover in as little as 3 minutes. And 3 minutes is, in most cases, insufficient for occupants to escape from a fire.

- How will the CPSC's plan protect furniture in which the cover material is compromised, such as through rough use, faulty stitching of seams, cat scratches, prior cigarette burns, etc.?
- The CPSC's Standard for Flammability of Mattress Sets (Open Flame) has as its goal "to minimize or delay flashover when a mattress is ignited in a typical bedroom fire."<sup>3</sup> Since upholstered furniture can have as much or more potentially flammable filling material than a typical mattress, why is flashover minimization/delay not a concurrent and equivalent goal of this rulemaking?

---

<sup>2</sup> Such research is summarized in the report "Fire Behavior of Upholstered Furniture," by Vytenis Babrauskas and John Krasny. NBS Monograph 173, National Engineering Laboratory, Center for Fire Research, National Bureau of Standards, November 1985.

<sup>3</sup> 16 CFR Part 1633, "Final Rule: Standard for the Flammability (Open Flame) of Mattress Sets," Federal Register, Vol. 71, No. 50, Wednesday, March 15, 2006, Consumer Product Safety Commission.



## NATIONAL ASSOCIATION OF STATE FIRE MARSHALS

April 14, 2008

Office of the Secretary  
Consumer Product Safety Commission  
4330 East West Highway  
Bethesda, MD 20814

Subject: Upholstered Furniture NPR

To the Commission:

The National Association of State Fire Marshals (NASFM) appreciates the opportunity to comment to the US Consumer Product Safety Commission (CPSC) on its proposed rule, "Standard for the Flammability of Residential Upholstered Furniture." As the original petitioners of this rulemaking proceeding on furniture, back in 1993, NASFM has more than a passing interest in its outcome, and we have followed the CPSC's actions closely in the time since the first Advance Notice of Proposed Rulemaking was issued in 1994. The CPSC has changed direction in its approach several times during that period.

On a related subject, we were greatly encouraged by the CPSC's issuance of a final residential mattress flammability rule in 2006 that requires mattresses to meet a very stringent open flame standard, to go along with the smoldering ignition standard that had been in place for over three decades. Consumers who purchase compliant mattresses are now truly protected against fires involving this product, which is present in – and represents a major fuel load in – virtually every home.

While upholstered furniture represents every bit as much a fuel load in the home as mattresses, consumers have not had the benefit of mandatory federal flammability standards for this product. The current rulemaking offered an opportunity for this deficiency in product safety to finally be addressed.

However, the proposed rule for upholstered furniture issued on March 4, 2008, has left us very puzzled and quite discouraged because of its failure to address two serious concerns: small open flame ignitions, and the protection of the filling materials, except in a small percentage of cases. By failing to address the flammability of upholstered furniture in a comprehensive way, the CPSC is abdicating, in large measure, its responsibility to protect consumers from unreasonable risks of serious injury or death from ignitions of upholstered furniture, which consistently have been responsible for more residential fire deaths than any other product under the CPSC's jurisdiction.

*The bottom line of NASFM's recommendation to the CPSC is that it must expand the current proposal to incorporate a small open flame ignition resistance requirement and to incorporate the protection of filling materials from both smoldering and open flame ignition. Anything less will cause an overall step backward in achieving adequate fire safety protection for consumers – which is unconscionable, particularly after so many years of studying this issue.*

The NASFM Board of Directors asked its Science Advisory Committee (SAC) to assist us in reviewing the notice of proposed rulemaking (NPR). The SAC, which was formed in 1997, is an esteemed group of scientific and technical advisors from the fire science, engineering, data analysis and product safety fields who advise the NASFM Board of Directors and NASFM members on a wide variety of safety issues. A list of SAC members and the SAC's recommendations to NASFM on this rulemaking are attached to these comments for the public record.

NASFM has decided to address its and the SAC's concerns about the proposed rule through a series of questions that we hope will create a focus for the CPSC as it proceeds with this rulemaking. Additionally, we acknowledge Commissioner Thomas Moore's thoughtful comments on this issue in his statement of December 27, 2007, and believe that the questions he raised are worthy of formal response by the CPSC staff.

#### **Questions about the proposal's failure to address ignitions by small open flame.**

Ignition of upholstered furniture by small open flames such as candles, matches and lighters are being ignored by the CPSC in this proposal, except in the small percentage of cases in which an interior fire barrier would be used with a smolder-prone cover fabric.

- The CPSC's data analysis seems to imply that the problem of small open flame ignition of upholstered furniture is going away on its own. Has the CPSC compared notes with other organizations that conduct data analyses of this sort (such as the National Fire Protection Association) to verify that the staff's interpretations of residential fire data are consistent with other professionals in the field? What precisely does such comparison indicate?
- The European Combustion Behaviour of Upholstered Furniture Program (CBUF) in the 1990s<sup>1</sup> demonstrated that the cover fabric is the controlling element in small open flame ignition of upholstered furniture, not the filling material. Given the fact that many cover fabrics that perform well in a smoldering test, such as synthetic fabrics,

---

<sup>1</sup> "Fire Safety of Upholstered Furniture – the final report on the CBUF research programme." Björn Sundström, ed. European Commission Measurements and Testing Report, EUR 16477 EN. In mock-up tests by seven laboratories on 20 fabrics and 18 filling materials, almost all fabrics that ignited by a small open flame did so with almost every filling material.

- Cotton batting filling was the major “bad actor” in cigarette-ignited mattress and furniture fires that resulted in the adoption of mandatory and voluntary requirements in the 1970s. Absent requirements for the adequate fire protection of filling materials, how does the CPSC plan to ensure that the current materials used as fillings in upholstered furniture would not be replaced by cheaper and even more flammable materials? Has the projected increase in fire losses as a result of the likely use of cheaper and more flammable filling materials been factored into the CPSC’s cost-benefit analysis of the proposed regulation?
- The CBUF research, as well as other research, also determined that the filling material is the controlling element in smoldering ignition of upholstered furniture, not the cover material. This work confirmed testing in the early 1970s that demonstrated that the cover fabrics used on conventional upholstered furniture provided no protection against the smoldering ignition of cotton batting filling.<sup>4</sup> If there is no requirement for the filling materials to either be protected or perform in a way to be resistant to ignition, and any filling material may be used, how does the CPSC plan to guard against the possibility that the cover fabric tested against the standard foam substrate of the proposed test protocol could be much more flammable with a different filling material beneath it (for example, cotton batting) when used in actual furniture?
- There are materials, in common use today as cushioning, located directly beneath the cover fabric, that are even more highly flammable than the standard polyurethane foam substrate specified in the test – examples are loose-fill shredded polyurethane cushioning and what is known as “slickened” polyester fiber. How will the CPSC ensure that the use of filling materials such as these will perform the same as, or better than, the standard polyurethane foam specified in the proposed test?

**Questions about the validation of the proposed standard.**

- The CPSC staff claim that the proposed smoldering ignition standard is more stringent than the UFAC program, but there are currently no validation data to demonstrate this. Where are the data demonstrating that the proposed smoldering standard is superior to UFAC in its protection of upholstered furniture?
- Large-scale validation tests are planned to ensure that the projected effects translate to how furniture behaves in the real world. How will the validation testing be conducted? What will the validation testing be designed to show?

---

<sup>4</sup> The earlier-cited NBS report, “Fire Behavior of Upholstered Furniture,” summarizes the research results referenced here.

- Will large-scale validation testing be completed before the issuance of a final rule? If the large-scale tests fail to validate the proposed standard, what does the CPSC plan to do?
- As one might reasonably expect, a limitation of large-scale validation tests on examples of today's furniture is that materials and styles will certainly change in the future due to fashion, economics, and any number of other influences. Such changes will invalidate today's tests and could result in less-safe furniture. How does CPSC plan to ensure that its tests will remain valid and result in safe products in light of future constructions of furniture?

**Questions about the proposed rule's effect on other upholstered furniture flammability standards.**

- In light of the CPSC's proposed federal regulation, the future of California Technical Bulletin 117 (TB 117) appears to be in jeopardy. Compliance with TB 117 protects upholstered furniture against both smoldering and small open flame ignitions and in part is met by flame-retarding the polyurethane foam filling material. TB 117 has been in effect for all residential upholstered furniture sold in California since the mid-1970s. Would TB 117 be preempted by the CPSC's standard? If the California Bureau of Home Furnishings and Thermal Insulation applied for a waiver to be able to continue enforcing TB 117 in California, would the CPSC grant the waiver? If TB 117 were to be preempted by the CPSC rule as currently proposed, has the expected increase in small open flame fires been factored into the CPSC's cost-benefit projections for its proposed regulation?
- It is estimated that 40% or more of the upholstered furniture currently being sold nationally complies voluntarily with California TB 117. Whether or not TB 117 is preempted by the proposed federal regulation, if the CPSC regulation does not require that filling materials be protected, the voluntary commitment by manufacturers would likely be abandoned in favor of the lower requirements of the federal regulation. Has the expected increase in small open flame fires if manufacturers do not voluntarily comply with TB 117 been factored into the CPSC's cost-benefit projections for its proposed regulation?
- California Technical Bulletin 133 (TB 133) is designed to protect furniture in institutional settings from large open flame ignitions. TB 133 has been adopted in several states and localities besides California. Would TB 133 be preempted by the CPSC's standard? If the California Bureau of Home Furnishings and Thermal Insulation applied for a waiver to be able to continue enforcing TB 133 in California (and other authorities applied for a waiver in their jurisdictions), would the CPSC grant the waiver? If TB 133 were to be preempted by the CPSC rule as currently

proposed, has the CPSC factored the expected increase in large open flame fires into the cost-benefit projections for its proposed regulation?

**Questions about construction in light of experience with the CPSC mattress regulation.**

The California Bureau of Home Furnishings, Underwriters Laboratories, the National Institute of Standards and Technology and mattress industry manufacturers themselves have reported failures of products complying with the new 16 CFR 1633 open flame standard for residential mattresses due to flame penetration into barrier seams that are not properly sewn. Even one dropped stitch can allow a flame to ignite filling materials, and this challenge has been a difficult one for mattress manufacturers to address.

- If interior fire-blocking barriers were used on upholstered furniture, there would be potentially many more seams than on a mattress. The open flame barrier test in the proposed upholstered furniture standard for “Type II” furniture does not address the integrity of seams used in barrier materials. How does the CPSC plan to address this potential source of vulnerability and failure in “Type II” furniture?

**Questions about certification requirements.**

A concern has been expressed by the North American Fire Testing Laboratories (NAFTL) consortium that the self-certification approach for mattress testing lacks language specifying proficiency in the use of the test method. As NASFM’s Science Advisory Committee has pointed out, without such a requirement, there has been a tendency for some mattress manufacturers and suppliers to engage in “lab shopping” – that is, searching for a laboratory that provides the desired results without regard to competency in the execution of the test.

- Does the CPSC plan to require that any laboratory used to test compliance with the proposed upholstered furniture standard be required to demonstrate proficiency in the use of the test method? How would such proficiency be demonstrated? If a requirement to demonstrate proficiency is not included as part of this regulation, how does the CPSC plan to prevent the problem of “lab shopping”?
- The CPSC plans to allow furniture manufacturers to self-certify compliance with this proposed standard. However, because upholstered furniture represents one of the largest components of residential fuel loads, NASFM strongly recommends that independent third-party certification be required. Would the CPSC consider a requirement of independent third-party certification as opposed to self-certification? If a requirement for independent third-party certification has been considered and rejected by the CPSC, what is the reason for this?

**Questions about the affect of activities by other organizations and agencies on the CPSC's rulemaking.**

- A new effort begun in the Fall of 2007 by Underwriters Laboratories (UL) and the Fire Protection Research Foundation (FPRF) aims to approach upholstered furniture flammability in a comprehensive way in part to provide guidance to the CPSC in its rulemaking. A wide range of stakeholders and the world's most prominent scientists in the field of upholstered furniture flammability are participating in this effort. CPSC staff have attended meetings on this project. Commissioner Moore has expressed optimism in the outcome of this effort. Does the CPSC plan to make use of the recommendations that result from the UL-FPRF research project?
- For many years prior to the issuance of the CPSC's proposed rule, the CPSC had worked in cooperation with the US Environmental Protection Agency (EPA) to ensure that if flame retardants (FRs) were to be used to meet a proposed upholstered furniture standard, they would be acceptable in terms of human health and environmental effects. For example, the EPA had expressed an intention to issue Significant New Use Rules under the Toxic Substances Control Act, which would require advance notification to and approval from EPA regarding commercialization of a chemical for "significant new use" as a fire retardant in residential upholstered furniture. Have any Significant New Use Rules been issued or are any being contemplated by EPA as part of this rulemaking? As part of the CPSC's decision to discourage the use of FRs through this rulemaking, has the partnership with EPA on this effort to ensure the safe application of FRs been abandoned?
- In addition, the Furniture Flame Retardancy Partnership, which was organized through the EPA's Design for the Environment program, aimed to "identify and move toward environmentally safer approaches to meeting fire safety standards." What is the status of the CPSC's involvement in the Furniture Flame Retardancy Partnership? Will this Partnership have a role as the rulemaking proceeds?
- The NPR notes that the National Toxicology Program (NTP) of the Department of Health and Human Services was asked by CPSC staff to undertake a long-term project to review several FRs that could be used to meet CPSC flammability rules. How will the results of this project be used, if at all, in a rulemaking?

**In summary.**

When it was first formed in 1973, the CPSC inherited a "Finding of Need" issued in November 1972 by the US Department of Commerce that initiated "proceedings for the development of an appropriate flammability standard or standards, or other regulation, including labeling, for upholstered furniture, and fabrics or related materials intended to



be used, or which may reasonably be expected to be used, in these products.”<sup>5</sup> When the CPSC first accepted NASFM’s petition for a national mandatory upholstered furniture flammability regulation in 1994, it was only to address small open flame ignitions of upholstered furniture. The CPSC added cigarette ignitions to the rulemaking in 2003, and now have abandoned small open flame ignitions, making cigarette ignitions the only focus of this proceeding.

The CPSC’s preferred approaches have ranged over the years from addressing only the ignition of the cover material, to primarily protecting the filling material, and back again to focusing only on the cover material. NASFM wishes that the CPSC would finally decide to address the problem of upholstered furniture fires comprehensively as part of its commitment to protect consumers. We believe that the rule as currently proposed would cause an overall step backward in fire safety and unintentionally result in more frequent and more severe fires in upholstered furniture. Because NASFM’s own mission is to protect life, property and the environment from fire, and because of our belief in “layers of safety,” we cannot accept the currently proposed regulation unless it is expanded to at least include resistance of furniture to small open flame ignition and protection of the filling materials in all cases, not just the 5% currently projected by the CPSC.

NASFM would appreciate the opportunity to present these comments orally in a public hearing.

Sincerely,

A handwritten signature in black ink, appearing to read "John C. Dean". The signature is fluid and cursive, with a large loop at the beginning and a long, sweeping tail.

John C. Dean  
President

Attachments

---

<sup>5</sup> 15 CFR Part 7, “Upholstered Furniture: Notice of Finding That Flammability Standard or Other Regulation May Be Needed and Institution of Proceedings,” Federal Register, Vol. 37, No. 230, Wednesday, Nov. 29, 1972, Department of Commerce.



## MEMORANDUM

---

**To:** John Dean, President *M. Simonson* **Date:** April 9, 2008

**From:** Margaret Simonson, Chair, NASFM Science Advisory Committee

**Re:** CPSC Proposed Rule, Standard for the Flammability of Residential Upholstered Furniture

---

As requested, the Science Advisory Committee (SAC) has reviewed the proposed rule dated March 4, 2008, by the US Consumer Product Safety Commission on the flammability of residential upholstered furniture. We provide the following comments for NASFM's consideration and use in preparing its public comments to the CPSC.

### General comment

While a national mandatory standard to address smoldering ignitions of upholstered furniture is long overdue, the standard currently proposed by the CPSC in its Notice of Proposed Rulemaking of March 4, 2008, is grossly deficient in two instances: its failure to address ignitions by small open flame, and its failure to protect against ignition of filling materials. Failure to address these issues severely blunts this proposal's ability to substantially reduce upholstered furniture fire losses. The SAC also is concerned that current levels of small open flame protection that exist in some of the upholstered furniture sold today nationally would be discontinued under the proposed rule, reversing gains in public safety that have more than likely contributed to the smaller proportion of open flame ignitions of furniture in recent data.

The SAC encourages NASFM to support the expansion of the existing proposed rule to incorporate a small open flame ignition requirement and to incorporate the protection of filling materials, so as not to permit an overall step backwards for fire safety.

### The proposed standard fails to address ignitions by small open flame.

- The proposed standard lacks a small open flame requirement (except in the small percentage of cases – called “Type II” by the CPSC – in which an interior fire barrier would be used with a smolder-prone cover fabric; the CPSC projects that barriers

would be used in an estimated 5% of complying upholstered furniture). Thus, a major cause of ignition of upholstered furniture (candles, matches, lighters) is being ignored by the CPSC.

- It is widely known that many cover fabrics that perform well in a smoldering test, such as synthetic fabrics, are highly vulnerable to open flame ignitions.<sup>1</sup> This is one of the challenges of trying to protect furniture against both types of ignitions. However, the answer is not to just pick one type of ignition to protect against, and ignore the other. Limiting attention to only smolder-resistant cover fabrics without a concurrent requirement to protect the furniture against open flame ignitions could result in more frequent, and more severe, open flame fires than currently are recorded.
- This is supported by research by the European Combustion Behaviour of Upholstered Furniture Program (CBUF) in the 1990s,<sup>2</sup> which demonstrated that the cover fabric is the controlling element in small open flame ignition of upholstered furniture, not the filling material. In mock-up tests by seven laboratories on 20 fabrics and 18 filling materials, almost all fabrics that ignited by a small open flame did so with almost every filling material.

#### The proposed standard fails to protect against ignition of filling materials.

- The proposed standard lacks a provision for protection of the filling material (again, except in the small percentage of cases that would be considered “Type II”), which is the largest fuel load within the item of furniture itself, as well as probably the largest fuel load within the entire room, if not the entire residence. If the cover material on a “Type I” piece of furniture is breached (which occurs quite frequently as experience has shown from rough use or simply a dropped stitch during manufacture), exposing the filling material to ignition, the result can be a fire that is hot enough to flash over a room in as little as 3 minutes. The CPSC should have a goal of not just preventing ignition, which is of course primary, but secondarily delaying the propagation of the fire to provide sufficient escape time to occupants. Escape time of 3 minutes is, in many cases, insufficient. A filling material standard would provide critical additional time to protect occupants from dying in fires that initiate in upholstered furniture.
- Without requirements for the adequate fire protection of filling materials, there is no assurance that the current materials used as fillings in upholstered furniture would not be replaced by cheaper and even more flammable materials. Cotton batting filling was the major “bad actor” in cigarette-ignited mattress and furniture fires that resulted in the adoption of mandatory and voluntary requirements in the 1970s.

---

<sup>1</sup> Such research is summarized in the report “Fire Behavior of Upholstered Furniture,” by Vytenis Babrauskas and John Krasny. NBS Monograph 173, National Engineering Laboratory, Center for Fire Research, National Bureau of Standards, November 1985.

<sup>2</sup> “Fire Safety of Upholstered Furniture – the final report on the CBUF research programme.” Björn Sundström, ed. European Commission Measurements and Testing Report, EUR 16477 EN.

- The CBUF research, as well as other research, also determined that the filling material is the controlling element in smoldering ignition of upholstered furniture, not the cover material. This work confirmed testing in the early 1970s that demonstrated that the cover fabrics used on conventional upholstered furniture provided no protection against the smoldering ignition of cotton batting filling.<sup>3</sup> Thus, absent a requirement for the filling materials to either be protected or perform in a way to be resistant to ignition, the cover fabric tested according to the proposed standard could perform very differently with a different filling material beneath it when used in actual furniture.
- Examples of materials even more highly flammable than the standard polyurethane foam substrate specified in the test are loose-fill shredded polyurethane cushioning and what is known as “slickened” polyester fiber, both of which are commonly used in residential upholstered furniture today directly beneath the cover fabric. The result of the standard that is currently proposed would be an upholstered furniture flammability test that fails to measure real-world performance.

CPSC staff have not provided data to validate their claims.

- The CPSC staff claim that the proposed smoldering ignition standard is more stringent than the UFAC program. Unfortunately, there is currently no validation data to demonstrate this. We advise NASFM to encourage the CPSC both to provide data demonstrating that the proposed smoldering standard is superior to UFAC in its protection of upholstered furniture, and to conduct the planned large-scale validation tests without delay to ensure that the projected effects translate to how furniture behaves in the real world.
- It is important to keep in mind one limitation of large-scale validation tests on examples of today’s furniture: materials and styles will certainly change in the future due to fashion and economic pressures. A valid performance standard must protect against future constructions that could result in less safe furniture. The CPSC should discuss how it would address this limitation as it proceeds with a standard.

Will the CPSC proposed federal regulation preempt California Technical Bulletins 117 and 133?

- In light of the CPSC’s proposed federal regulation, the SAC is concerned about the future of California Technical Bulletin 117, which protects upholstered furniture against both smoldering and small open flame ignitions and in part is met by flame-retarding the polyurethane foam filling material. TB 117 is currently in effect for all residential upholstered furniture sold in California, and if it is preempted by this CPSC proposed rule, it would amount to a reversal of a major public safety regulation

---

<sup>3</sup> The earlier-cited NBS report, “Fire Behavior of Upholstered Furniture,” summarizes the research results referenced here.

that has been in effect for over 30 years in one of the most populous states in the nation.

- Additionally, it is estimated that 40% or more of the upholstered furniture currently being sold nationally complies voluntarily with California Technical Bulletin 117, which addresses both smoldering and small open flame ignitions of upholstered furniture. Absent a requirement to protect the filling materials in furniture under this proposed rule, along with the preemption of California TB 117, the SAC is concerned that the voluntary commitment by manufacturers also would be abandoned, further reversing public safety gains.
- This calls into question the CPSC staff economic analysis. If the estimated 40% or more of upholstered furniture that currently complies with California Technical Bulletin 117 will be manufactured to meet the lower requirements of the Federal regulation, fires, injuries and deaths due to small open flame ignition are very likely to increase. The CPSC staff economic analysis did not take this into consideration. Again, there is no assurance that the current materials used in upholstered furniture would not be replaced by cheaper and even more flammable materials.
- The federal preemption might also extend to California Technical Bulletin 133, which is designed to protect furniture in institutional settings from large open flame ignitions. TB 133 has been adopted in several states and localities besides California.

#### Construction – Experience with the CPSC mattress regulation applies to upholstered furniture.

- The California Bureau of Home Furnishings, Underwriters Laboratories, National Institute of Standards and Technology and mattress industry manufacturers themselves have reported failures of products complying with the new 16 CFR 1633 open flame standard for residential mattresses due to flame penetration into barrier seams that are not properly sewn. Even one dropped stitch can provide entrée for a flame to ignite filling materials, and this challenge has been a difficult one for mattress manufacturers to address.
- If interior fire-blocking barriers were used on upholstered furniture, there would be potentially many more seams than on a mattress. The open flame barrier test in the proposed upholstered furniture standard for “Type II” furniture does not address the integrity of seams used in barrier materials. We encourage NASFM to inquire as to how the CPSC plans to address this potential source of vulnerability in “Type II” furniture.

#### Certification

- A concern has been expressed by the North American Fire Testing Laboratories (NAFTL) consortium that the self-certification approach for mattress testing lacks language specifying proficiency in the use of the test method.

- The SAC strongly suggests a requirement that any laboratory used to test compliance with the proposed upholstered furniture standard be required to demonstrate proficiency in the use of the test method. Without such a requirement, there may be a tendency for manufacturers and suppliers to engage in “lab shopping,” to find a laboratory that provides the desired results without regard to competency in the execution of the test.
- The CPSC plans to allow furniture manufacturers to self-certify compliance with this proposed standard. However, because this product represents one of the largest components of residential fuel loads, the SAC strongly recommends that independent third-party certification (such as that being considered by Congress for toys in the anticipated reauthorization legislation affecting CPSC) be required.

#### Use of flame retardants.

- For many years prior to the issuance of the CPSC’s proposed rule, the CPSC had worked in cooperation with the US Environmental Protection Agency (EPA) to ensure that if flame retardants were to be used to meet a proposed upholstered furniture standard, they would be acceptable in terms of human health and environmental effects. For example, the EPA had expressed an intention to issue Significant New Use Rules under the Toxic Substances Control Act, which would require advance notification to and approval from EPA regarding commercialization of a chemical for “significant new use” as a fire retardant in residential upholstered furniture. In addition, the Furniture Flame Retardancy Partnership, which was organized through the EPA’s Design for the Environment program, aimed to “identify and move toward environmentally safer approaches to meeting fire safety standards.” Given the CPSC’s current desire to provide options that do not require the use of fire retardants, it may be worth inquiring about the status of the EPA’s efforts in this regard and if EPA will have a role moving forward.

#### In summary

The SAC urges NASFM to place these and any other concerns about this proposed rule on the CPSC public record, with the goal of expanding the current proposal into a meaningful flammability standard that addresses both smoldering and small open flame ignitions of upholstered furniture and that adequately protects the filling materials from ignition in order to provide occupants with sufficient escape time in the event that the cover fabric fails to prevent a fire from spreading.



**Members**  
**National Association of State Fire Marshals**  
**Science Advisory Committee**

Margaret Simonson, Ph.D., *Chair*  
Research Manager  
SP Technical Research Institute of Sweden

J. William Degnan, *NASFM Board Liaison to the SAC*  
New Hampshire State Fire Marshal

Geoffrey N. Berlin, Ph.D.  
Mathematician, Statistician, and Decision Support Consultant

Gordon H. Damant  
Consultant, Fire Investigations and Flammability of Clothing and Furnishings

Roy Deppa, P.E.  
Consumer Product Safety Consultant  
Marchica & Deppa, LLC

William L. Grosshandler, Ph.D.  
Deputy Director, Building and Fire Research Laboratory  
National Institute of Standards and Technology

James F. Hoebel  
Chief Engineer for Fire Safety (Ret.)  
US Consumer Product Safety Commission

Nick Marchica  
Consumer Product Safety Consultant  
Marchica & Deppa, LLC

Steven Spivak, Ph.D.  
Professor Emeritus and past Chair of Department  
Fire Protection Engineering, University of Maryland

John M. Watts, Jr., Ph.D.  
Director  
Fire Safety Institute

**Stevenson, Todd**

---

**From:** KFernico@aol.com  
**Sent:** Tuesday, April 15, 2008 10:38 AM  
**To:** CPSC-OS  
**Cc:** Ray, Dale  
**Subject:** Upholstered Furniture NPR  
**Attachments:** NASFMtoCPSCApr08FINAL.pdf

Attached is a submission from the National Association of State Fire Marshals to the CPSC on the Notice of Proposed Rulemaking, Standard for the Flammability of Residential Upholstered Furniture. Please confirm receipt of this email.

Thank you,  
Karen Suhr  
Government Relations  
National Association of State Fire Marshals  
202-737-1226

---

It's Tax Time! Get tips, forms and advice on [AOL Money & Finance](#).





Surgery Faculty Practice

*Upholstered  
Furniture 4*

CPSC/OPIC OF THE SECRETARY  
FREEDOM OF INFORMATION

April 14, 2008

2008 APR 22 P 2:53

San Francisco General Hospital  
Box 0807  
San Francisco, CA 94143-0807  
tel: 415/206-8814  
fax: 415/206-5484

Office of the Secretary  
Consumer Product Safety Commission  
4330 East West Highway  
Bethesda, MD 20814

Andre R. Campbell, M.D.  
General Surgery

Dear Chairwoman Nord:

David S. Chang, M.D.  
Plastic Surgery

I am writing to express my concerns for the direction the CPSC is moving in regard to fire safety standards on residential furniture. As a medical professional, I see first-hand the devastating affects of burn injuries on survivors and their families. It is my responsibility not only to treat the wounds that come into the hospital, but also to do everything in my power to prevent these often-avoidable accidents from occurring. I am alarmed by the proposed measures by the CPSC, as they do not seem to be moving toward more extensive fire safety standards, but instead further away from it.

Mitchell Jay Cohen, M.D.  
General/Trauma Surgery

Currently, fires starting on upholstered furniture and mattresses are responsible for over 35 percent of fire-related deaths, claiming the lives of up to 17 people each week. Despite this staggering statistic, the Commission is considering a measure to remove the heavily studied flame retardants in the foam of furniture.

Rochelle A. Dicker, M.D.  
General Surgery

Chemical flame retardants are used to protect the foam as well as the covering fabric from both small open flames and smoldering ignition. While they do not put out fires, they do provide crucial added time for the occupants to leave the residence thus saving lives. The reduction in fire deaths over the years has been attributed to the use of approved and studied chemical flame retardants. To eliminate this important element from the fire safety arsenal will result in an increase in fire deaths and property damage.

Arthur C. Hill, M.D.  
Cardiothoracic Surgery

Fire-related injuries are some of the most costly and emotionally damaging injuries, and without appropriate fire retardant protection, the risk for fire-related deaths is unimaginable. Approving this kind of measure would be a step in a very dangerous direction for the CPSC. To date, this type of legislation has been reviewed by 48 states and has been repeatedly turned down.

Jan K. Horn, M.D.  
General Surgery

It is crucial that the CPSC understands that the medical community stands on the side of fire safety and opposes any action to lessen the existing fire safety standards.

M. Margaret Knudson, M.D.  
Breast/Pediatric Surgery

The current flammability standards play a significant role in residential fire safety and the proposed measures to eliminate these effective fire prevention tools should be revisited by the CPSC.

Robert C. Mackersie, M.D.  
General Surgery

Mahesh H. Mankani, M.D.  
Plastic/Hand Surgery

Stanley J. Rogers, M.D.  
Minimally Invasive and  
General Surgery

William P. Schechter, M.D.  
General Surgery

Vivian Ting, M.D.  
Plastic Surgery

David M. Young, M.D.  
Plastic Surgery

Sincerely yours,

William P. Schechter, M.D.  
Professor of Clinical Surgery  
University of California, San Francisco  
Chief of Surgery  
San Francisco General Hospital

DISTRICT OFFICE  
4818 W. 137th St., Ste. 2  
Crestwood, Illinois 60445  
708-396-2822 Suburban  
773-291-1288 Chicago  
708-396-2898 Fax

SPRINGFIELD OFFICE  
292-S Stratton Building  
Springfield, Illinois 62706  
217-558-1000  
217-558-1091 Fax

e-mail: robertbobrita@aol.com

ILLINOIS HOUSE OF REPRESENTATIVES



*Robert A. Rita*

STATE REPRESENTATIVE - 28<sup>TH</sup> DISTRICT

*Robert A. Rita*

COMMITTEES

- Chairman - Tollway Oversight
- Vice Chairman  
Health & Healthcare Disparities
- Executive
- Consumer Protection
- Environment & Energy
- Insurance

5

April 18, 2008

Office of the Secretary  
Consumer Product Safety Commission  
4330 East West Highway  
Bethesda, MD 20814

Dear Chairwomen Nord:

I am writing to express my concerns for the direction the CPSC is moving towards in response to fire safety standards on residential furniture. As leaders in our state, we must fulfill our promise to our constituents, to establish sound legislation that will protect every citizen and put their safety above all other concerns.

In 2004, all stakeholders reached a consensus on a standard that would make sure all parts of a piece of furniture are flame retarded. It was agreed that both the covering textile and the foam needed to be retarded in order solve the problem of furniture fires. Ignoring this consensus, the CPSC staff continued to release proposals either calling for treating the covering fabric or the foam but not the entire piece of furniture.

Chemical flame retardants are used to protect the foam as well as the covering fabric from both small open flames and smoldering ignition. While they do not put out fires, they do provide crucial added time for the occupants to leave the residence thus saving lives. The reduction in fire deaths over the years has been attributed to the use of approved and studied chemical flame retardants. To eliminate this important tool from the fire safety tool box will result in an increase in fire deaths and property damage.

In fact, it is quite possible that measures like the one being considered by the Commission could weaken some of the toughest laws in the country such as California's furniture safety standard. On another note, 84% of furniture designed with no protection in the foam tends to be the class of furniture that finds its way either in its original or second-hand form in lower income households who cannot afford the higher-value, barrier protected furniture. The proposal does not address the increased danger that these citizens may be exposed to.

We have the opportunity to do this right the first time. The CPSC must take the time and consideration to propose a concept that will not require adjustments and further debate in the coming years.

To finalize a standard that will lead to high protection from fire for one end of the economic spectrum and a lesser standard for those at the lower end is not fire protection for all consumers. The CPSC should reconsider the stakeholder agreement from 2004, designed to protect the fabric and the foam, resulting in a standard that will provide the maximum protection to the public.

Sincerely,

A handwritten signature in cursive script that reads "Bob Rita".

Robert A. Rita  
State Representative  
28<sup>th</sup> District



Updated From 6

April 15, 2008

Office of the Secretary  
Consumer Product Safety Commission  
4330 East West Highway  
Bethesda, MD 20814

CPSC/OFC OF THE SECRETARY  
FREEDOM OF INFORMATION

2008 APR 22 P 2: 53

Dear Chairman Nord:

I am writing to express my concerns for the direction the CPSC is moving towards in lessening the fire safety standards in the manufacturing industry.

In 1998, the CPSC reviewed the 16 chemical flame retardants that could be used to meet a flammability standard. 8 of those 16 were deemed safe and effective for use. For the CPSC to now say chemical flame retardants do not need to be used to meet a standard is setting a dangerous precedent. While the staff proposal does not specifically say chemical flame retardants should not be used, the statement that a standard should not rely on chemical flame retardants will result in foam manufacturers discontinuing use of this important safety product.

As a person who runs a trade association, the CPSC proposal compromises my position as a corporate leader because there will be no means of ensuring that the new approved and un-studied flame retardants are as effective as those currently being used.

Chemical flame retardants are used to protect the foam as well as the covering fabric from both small open flames and smoldering ignition. While they do not put out fires, they do provide crucial added time for the occupants to leave the residence, thus saving lives. The reduction in fire deaths over the years has been attributed to the use of approved and studied chemical flame retardants. To eliminate this important tool from the fire safety tool box will result in an increase in fire deaths and property damage.

In 2004, fire-fighters, physicians, environmentalists and manufacturers reached a consensus on a standard that would make sure all parts of a piece of furniture are flame retarded. It was agreed that both the covering textile and the foam needed to be retarded in order solve the problem of furniture fires. Ignoring this consensus, the CPSC staff continued to release proposals either calling for treating the covering fabric or the foam, but not the entire piece of furniture.

Leaders like myself, need the Commission to develop a standard that will provide the maximum protection to the public in order to ensure quality products from manufacturers. The CPSC should reconsider the prior stakeholder agreements, designed to protect the fabric and the foam and to set an industry standard for fire safety.

Sincerely,

Mark A. Biel  
Executive Director

**Headquarters**

2250 E. DEVON AVENUE, SUITE 239, DES PLAINES, IL 60018 • TEL: (847) 544-5995 • FAX: (847) 544-5999

**Springfield**

400 W. MONROE SUITE 205, SPRINGFIELD, IL 62704 • TEL: (217) 522-5805 • FAX: (217) 522-5815  
cc: cpsc-osa@cpsc.gov

**Website:** www.cicil.net

April 21, 2008  
Office of the Secretary  
Consumer Product Safety Commission  
4330 East West Highway  
Bethesda, MD 20814

*Upcoming  
Furn.* 7

Dear Chairwomen Nord:

I am writing to express my concerns for the direction the CPSC is moving towards in lessening the fire safety standards in the manufacturing industry.

In 1998, the CPSC reviewed the 16 chemical flame retardants that could be used to meet a flammability standard. 8 of those 16 were deemed safe and effective for use. For the CPSC to now say chemical flame retardants do not need to be used to meet a standard is irresponsible. While the proposal does not specifically say chemical flame retardants should not be used, the statement that a standard should not rely on chemical flame retardants goes against years of research that proves their importance in residential fires.

Small business owners are responsible for consumer safety and strive to distribute products and provide services that meet the highest standards of fire protection. The proposal compromises my position as an ethical entrepreneur because I will no longer be able to guarantee that my customers are protected by the approved and studied chemical flame retardants.

Chemical flame retardants are used to protect foam as well as covering fabric from both small open flames and smoldering ignition. While they do not put out fires, they do provide crucial added time for the occupants to leave the residence, thus saving lives. The reduction in fire deaths over the years has been attributed to the use of approved and studied chemical flame retardants. To eliminate this important tool from the fire safety tool box will result in an increase in fire deaths and property damage.

In 2004, fire-fighters, physicians, environmentalists and manufacturers reached a consensus on a standard that would make sure all parts of a piece of furniture and other foam-based products are flame retarded. It was agreed that both the covering textile and the foam needed to be retarded in order solve the problem of residential fires. Ignoring this consensus, the CPSC staff continued to release proposals either calling for treating the covering fabric or the foam, but not the entire product.

Small business owners need the Commission to develop a standard that will provide the maximum protection to the public. The CPSC should reconsider the prior stakeholder agreements, designed to protect the public and to set an industry standard for fire safety.

Sincerely,

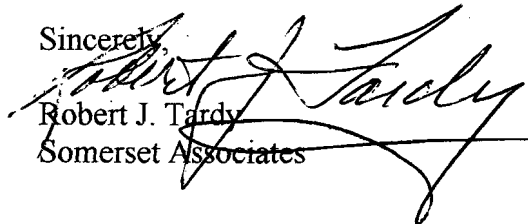
  
Robert J. Tardy  
Somerset Associates

cc: cpsc-os@cpsc.gov

STATE CAPITOL  
P.O. BOX 942849  
SACRAMENTO, CA 94249-0038  
(916) 319-2038  
FAX (916) 319-2138

DISTRICT OFFICE  
23734 VALENCIA BLVD., SUITE 303  
SANTA CLARITA, CA 91355  
(661) 286-1565  
FAX (661) 286-1408

Assembly  
California Legislature



CAMERON SMYTH  
ASSEMBLYMEMBER, THIRTY-EIGHTH DISTRICT

8  
COMMITTEES:  
VICE CHAIR, ENVIRONMENTAL  
SAFETY AND TOXIC  
MATERIALS  
LOCAL GOVERNMENT  
UTILITIES AND COMMERCE

April 24, 2008

Office of the Secretary  
Consumer Product Safety Commission  
4330 East West Highway  
Bethesda, MD 20814

Dear Chairwoman Nord:

I am writing to express concern about the direction the Consumer Product Safety Commission is taking in establishing fire safety standards for residential furniture. As a member of the California Legislature, I must fulfill my promise to my constituents to establish sound regulations that will protect every California citizen and put their safety above all other concerns.

The performance-based standards established by California's Bureau of Home Furnishings and Thermal Insulation evaluate the ability of furniture products to withstand both open flames and smoldering cigarettes. Measures like the one currently being considered by the CPSC could preempt California's furniture fire safety standards, which are viewed nationally by fire safety officials as the "gold standard." The CPSC proposal could also derail progress toward development and application of more protective fire safety standards to a broader range of consumer products.

For example, by limiting the scope of its proposal to cover fabrics, subject only to a smoldering ignition source, the CPSC proposal fails to address the increased fire danger that low income citizens face from less expensive furniture products that may not include adequate fire safety measures. Approximately 84 percent of furniture using foam fill that is either not treated for fire resistance or wrapped inside a flame resistant barrier tends to find its way, either in original or second-hand form, into lower income households. This foam, which fire officials have likened to "solid gasoline," presents an extreme hazard that will not be addressed by the current proposal.

It is my understanding that a stakeholder consensus was reached in 2004 on a federal flammability standard that addressed all of the individual components that make up a given piece of furniture. This is an approach that has been in place in California for some time, and has proven effective in reducing fires and resulting injuries and deaths, as evidenced by the lower incidences of all three outcomes. My concern is that the current CPSC proposal could actually undermine this lifesaving progress by preempting and

replacing California's comprehensive, proven approach to fire safety with a less protective standard.

Furniture should be made as fire safe as possible, and the standard for testing that level of protection should be comprehensive and not leave out such obvious potential sources of fire as an open flame. While it is not practical to make furniture 'fire proof,' making furniture fire safe is achievable through a variety of means and doing so can provide crucial added time for occupants to escape and for emergency responders to gain control of a fire.

It is critical that the CPSC set an appropriate, practical standard that addresses real-world situations and economics. The CPSC should promulgate a standard that will provide adequate and equivalent fire protection for all consumers across the economic spectrum, and it should not undermine strong, proven measures that are already in place, such as in California.

I encourage the CPSC to reexamine the model stakeholder agreement reached in 2004 and propose a comprehensive furniture flammability standard that will provide maximum protection to all citizens and not preempt those states that have already adopted such measures.

Sincerely,

A handwritten signature in black ink, appearing to read 'Cameron M. Smyth', written in a cursive style.

**CAMERON M. SMYTH**  
**Assemblyman, 38<sup>th</sup> District**  
**Vice Chair of Environmental Safety and Toxic Materials Committee**



Upholst  
Furn  
MPA  
9

---

## Illinois Manufacturers' Association

April 29, 2008

Office of the Secretary  
Consumer Product Safety Commission  
4330 East West Highway  
Bethesda, MD 20814

Dear Chairwomen Nord:

On behalf of the Illinois Manufacturers' Association (IMA) and its 4,000 member companies, I would respectfully like to express our concerns regarding possible changes that will be made by the Consumer Products Safety Commission (CPSC) with respect to fire safety standards on residential furniture. In our opinion, the proposed changes being considered will cause harm to employers and more importantly the residents of the United States.

Over the years, there has been a significant reduction in fire deaths due to the direct use of approved chemical flame retardants. The use of these products has been studied and deemed safe by a variety of independent sources. At this point, eliminating this tool from the fire safety tool box will result in increased fatalities, injuries and property damage.

Simply stated, chemical flame retardants are used to protect the foam as well as the covering fabric from both small open flames and smoldering ignition. While they do not put out fires, they provide crucial time for building occupants to flee a fire and additional time for firefighters to respond.

Secondly, the new measures will disproportionately impact low-income and minority communities. Studies show that 84 percent of furniture designed with no protection in the foam tends to be in the class of furniture that ends up in the lower-income or minority households either in its original or second-hand form. Many of these individuals will be unable to purchase costly furniture with these new standards.

It is critical that the CPSC study and understand the negative ramifications of its potential action. Not only will it harm the economy, but it will make a sector of our citizens less safe. The IMA recommends that the CPSC reconsider the standard and work to ensure a workable solution that will protect Americans.

Regards,

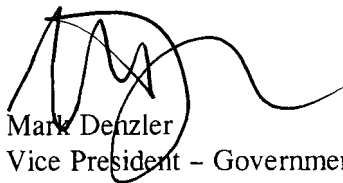

Mark Denzler  
Vice President – Government Affairs & Membership



*Update,  
From NPR* 10

# NJCC

THE STATE CHAMBER

---

April 29, 2008

Office of the Secretary  
Consumer Product Safety Commission  
4330 East West Highway  
Bethesda, MD 20814

Dear Chairwomen Nord:

I am writing on behalf of the New Jersey State Chamber of Commerce ("State Chamber") to express our concerns for the direction the CPSC is moving regarding fire safety standards on residential furniture. We are alarmed by the proposed measures the CPSC is considering.

The State Chamber, which seeks to promote the uniqueness and diversity of our members and to empower our citizens, foresees that the proposal will cause unanticipated harm to the economic and personal well-being of our residents. The State Chamber consists of leaders in business, community and governmental sectors who fear that the proposal will disproportionately affect low-income and minority communities. These individuals will be financially unable to fulfill the necessary adjustments the CPSC proposal requires, making the proposal a direct threat to lower-income and minority communities.

The reduction in fire deaths over the years has been attributed to the use of approved and studied chemical flame retardants. To eliminate this important tool from the fire safety tool box will result in an increase in fire deaths and property damage. Chemical flame retardants are used to protect the foam as well as the covering fabric from both small open flames and smoldering ignition. While they do not put out fires, they do provide crucial added time for the occupants to leave the residence, thus saving lives.

In addition, 84% of furniture designed with no protection in the foam tends to be the class of furniture that finds its way either in its original or second-hand form in lower income households who cannot afford the higher-value, barrier protected furniture.

To finalize a standard that will lead to high protection from fire for one end of the economic spectrum and a lesser standard for those at the lower end is not fire protection for all consumers.

The State Chamber is charged with making New Jersey and our communities a better place to work, live and play. With this mission in mind, we recommend that the CPSC reconsider the stakeholder agreement from 2004, designed to protect the fabric and the foam in furniture, resulting in a standard that will provide the maximum protection to the public.

Sincerely,



MICHAEL A. EGENTON  
Vice President – Environment & Transportation

CPSC/OFC OF THE SECRETARY  
FREEDOM OF INFORMATION  
2008 APR 32 A 11:34

STATE CAPITOL  
P.O. BOX 942849  
SACRAMENTO, CA 94249-0066  
(916) 319-2066  
FAX (916) 319-2166

DISTRICT OFFICE  
41391 KALMIA STREET, SUITE 220  
MURRIETA, CA 92562  
(951) 894-1232  
FAX (951) 894-5053

Assembly  
California Legislature



KEVIN JEFFRIES  
ASSEMBLYMEMBER, SIXTY-SIXTH DISTRICT

*Uphold  
Law NRA*

COMMITTEES  
PUBLIC EMPLOYEES, RETIREMENT  
AND SOCIAL SECURITY  
GOVERNMENTAL ORGANIZATION  
ENVIRONMENTAL SAFETY AND  
TOXIC MATERIALS

11

April 30, 2008

Office of the Secretary  
Consumer Product Safety Commission  
4330 East West Highway  
Bethesda, MD 20814

Dear Chairwoman Nord:

I am writing to express concern about the direction the Consumer Product Safety Commission is taking in establishing fire safety standards for residential furniture. After serving 29 years in the fire service, I know the importance of these standards in fire prevention. As a current member of the California State Legislature, I must fulfill my promise to my constituency to establish sound regulations that will protect every California citizen and put their safety above all other concerns.

The performance-based standards established by California's Bureau of Home Furnishings and Thermal Insulation evaluate the ability of furniture products to withstand both open flames and smoldering cigarettes. Measures like the one currently being considered by the CPSC could preempt California's furniture fire safety standards, which are viewed nationally by fire safety officials as the "gold standard." The CPSC proposal could also derail progress toward development and application of more protective fire safety standards to a broader range of consumer products.

For example, by limiting the scope of its proposal to cover fabrics, subject only to a smoldering ignition source, the CPSC proposal fails to address the increased fire danger that low income citizens face from less expensive furniture products that may not include adequate fire safety measures. Approximately 84 percent of furniture using foam-fill that is either not treated for fire resistance or wrapped inside a flame resistant barrier tends to find its way, either in original or second-hand form, into lower income households. This foam, which fire officials have likened to "solid gasoline," presents an extreme hazard that will not be addressed by the current proposal.

It is my understanding that a stakeholder consensus was reached in 2004 on a federal flammability standard that addressed all of the individual components that make up a given piece of furniture. This is an approach that has been in place in California for some

time, and has proven effective in reducing fires and resulting injuries and deaths, as evidenced by the lower incidences of all three outcomes. My concern is that the current CPSC proposal could actually undermine this lifesaving progress by preempting and replacing California's comprehensive, proven approach to fire safety with a less protective standard.

Furniture should be made as fire-safe as possible, and the standard for testing that level of protection should be comprehensive and not leave out such obvious potential sources of fire as an open flame. While it is not practical to make furniture "fire proof," making furniture fire safe is achievable through a variety of means and doing so can provide crucial added time for occupants to escape and for emergency responders to gain control of a fire.

It is critical that the CPSC set an appropriate and practical standard that addresses real-world situations and economics. The CPSC should promulgate a standard that will provide adequate and equivalent fire protection for all consumers across the economic spectrum, and it should not undermine strong, proven measures that are already in place, such as in California.

I encourage the CPSC to reexamine the model stakeholder agreement reached in 2004 and propose a comprehensive furniture flammability standard that will provide maximum protection to all citizens and not preempt those states that have already adopted such measures.

Sincerely,

A handwritten signature in black ink, appearing to read "Kevin Jeffries", with a large circular flourish on the left side.

Kevin Jeffries  
California State Assembly  
Assemblymember, 66<sup>th</sup> District

cc: [cpsc-os@cpsc.gov](mailto:cpsc-os@cpsc.gov)

# California Legislature

May 1, 2008

Office of the Secretary  
Consumer Product Safety Commission  
4330 East West Highway  
Bethesda, MD 20814

Dear Chairwoman Nord:

We the undersigned members of the California State Legislature would like to express our support for the U.S. Consumer Product Safety Commission's (CPSC) proposed regulations to improve fire safety for furniture products. These new regulations will help reduce fire-related mortalities and injuries nationally as well as in California and we support these prudent standards.

The new regulations are the result of years of study and deliberation by the CPSC and they are supported by a wide range of furniture industry groups, consumer advocates, environmental organizations, and fire safety proponents. In the proposed standard the CPSC notes that open-flame tests on components found inside furniture, such as the one mandated by California's outdated TB 117 test procedure, leads to the use of some fire retardant chemicals "that could pose both cancer and non-cancer chronic health risks."

We agree that it is not prudent to mandate the use of halogenated fire retardants in intimate use products like furniture, mattresses, and bedding, and have been working to modify TB 117 through legislation known as AB 706 now pending in the California Senate. We support the CPSC's strong performance-based standard that is reflective of how fires actually start instead of an open-flame provision for filling materials in the nation's furniture.

A letter being circulated in the California Legislature by the bromine industry charges that the new CPSC regulations would compromise fire safety in California and that it would increase the cost of furniture for low-income communities. These charges are false. In the 30 years that California has required our furniture to contain toxic fire retardants we have not seen a greater reduction in fire deaths than has occurred in other states without the fire retardant mandate. Furthermore, the new CPSC standard is likely to make furniture more affordable for low-income communities in California by removing some costs in the manufacturing process, and providing for a uniform national standard that does not require two sets of inventory – one for California, and another for the other 49 states.



It's time California reformed our state's fire safety standard to achieve equivalent fire safety without toxic bromine industry chemicals. We the undersigned members of the California State Legislature support the proposed CPSC regulations and request that you move forward with full approval of these important fire safety standards.

Sincerely,

Mark Leno

Sally Likhacheva MA

Mary Salas

Michaela Hanan

Gene Quinn

Mark S. S. S.

Betty Karnette

NAVA

Ruentez RIENTES

Travis Davis

HERNANDEZ

Patty Berg

Chris Burrows

Jose Solari

David J. Irwin

Mark S. S. S.

Anthony Portantino

Steven Eng

Gregory Price PRICE

John C. C.

Michael S.

Sh. K. S.

JONES

Q, R, L

John Lind

Paul Huffman

Law

STATE CAPITOL  
P.O. BOX 942849  
SACRAMENTO, CA 94249-0013  
(916) 319-2013  
FAX (916) 319-2113  
DISTRICT OFFICE  
455 GOLDEN GATE AVE., SUITE 14300  
SAN FRANCISCO, CA 94102  
(415) 557-3013  
FAX (415) 557-3015  
assemblymember.leno@assembly.ca.gov  
www.asm.ca.gov/leno

# Assembly California Legislature



**MARK LENO**  
ASSEMBLYMAN, THIRTEENTH DISTRICT

**COMMITTEES**  
APPROPRIATIONS, CHAIR  
ELECTIONS AND REDISTRICTING  
LABOR AND EMPLOYMENT  
PUBLIC SAFETY

May 16, 2008

Members of the California State Assembly signing the letter in support of the U.S. Consumer Product Safety Commission's proposed rule, "Standard for the Flammability of Residential Upholstered Furniture" (16 CFR Part 1634) without a small open flame standard for foam.

Mark Leno (San Francisco)

Patty Berg (Eureka)

Fiona Ma (San Francisco)

Julia Brownley (Santa Monica)

Sally Lieber (Mountain View)

Jose Solorio (Santa Ana)

Mary Salas (Chula Vista)

Wilmer Amina Carter (Rialto)

Mary Hayashi (Hayward)

Mervyn Dymally (Los Angeles)

Gene Mullin (South San Francisco)

Anthony Portantino (Pasadena)

Mark DeSaulnier (Martinez)

Noreen Evans (Santa Rosa)

Betty Karnette (Long Beach)

Curren Price (Inglewood)

Pedro Nava (Santa Barbara)

Joe Coto (San Jose)

Felipe Fuentes (Los Angeles)

Mike Feuer (Los Angeles)

Mike Davis (Los Angeles)

Sandré Swanson (Oakland)

Ed Hernandez (Baldwin Park)

Dave Jones (Sacramento)

Ira Ruskin (Redwood City)

Jared Huffman (San Rafael)

John Laird (Santa Cruz)

Loni Hancock (Berkeley)



**Coats  
North America**

Coats North America  
3430 Toringdon Way  
Suite 301  
Charlotte, NC 28277  
Telephone: 704/329-5800  
Fax: 704/329-5827

*Upholstery  
From  
NFR  
13*

May 2, 2008

US Consumer Products Safety Commission  
4330 East West Highway  
Bethesda, Md 20814

Attn: Mr. Dale Ray,

Coats has reviewed the proposed CPSC 16CFR Part 1634 draft and found several areas where we would like to suggest amendments to the document. I am attaching a copy of the draft with highlighted and numbered sections showing where we feel changes should be made in order to produce more consistent, relevant and dependable legislation.

We are asking that the flammability testing not be limited to only fabrics but extended to include seams as well. As you might well imagine, we feel that an upholstery seam is more likely to be subject to flame risk than would be plain fabric. There is also the precedent set forth in CFR 1633 mattress legislation which does include seam flammability testing.

Please consider these suggested changes and let us know if you feel that some or all of them could be included in the next draft of the CFR.

- 1) (f) *Upholstery cover fabric* means the outermost layer of attached fabric or other material, such as leather and sewing threads in seams, used to cover the seating area of the upholstered furniture item.
- 2) (s) *Specimen* means an individual piece of upholstery fabric, barrier material, and sewing threads in seams, as defined in paragraph (n) of this section, used in a mockup assembly for smoldering or open flame ignition testing.
- 3) (c) *Summary of § 1634.4 through § 1634.5 tests.* The test methods set forth in §§ 1634.4 through 1634.6 measure the flammability performance (resistance to smoldering or small open flame ignition) of cover fabrics, fire barrier materials, and sewing threads in seams through a series of tests using small scale mockups representative of the typical construction of upholstered furniture.
- 4) Vertical and horizontal panels of a standard foam substrate are covered, using the upholstery cover fabric to be tested. The standard cover fabric can be with or without stitched seams
- 5) The mockup must not continue to smolder nor the sewn seams rupture at the end of the test or transition to flaming at any time during the test, and the substrate must not exceed the mass loss limit.
- 6) (c) *Significance and use.* This test method is designed to measure the resistance of an upholstery cover fabric and any associated seams to a smoldering ignition source when the fabric and/or seams is placed over a standard polyurethane foam substrate.
- 7) (5) At 45 minutes, if the mockup assembly is smoldering or if stitched seams have ruptured, record a failure for the mockup and extinguish with appropriate means and proceed to paragraph (m) of this section. See Subparts C and D of this part.



8) (m) Pass/fail criteria. (1) The sample passes the requirements of this test procedure if the following criteria are met:

- (i) ok as written
- (ii) ok as written
- (iii) ok as written
- (iv) No stitched seam has failed with rupture from melting or burning.

9) Vertical and horizontal panels of the interior fire barrier material to be tested are placed between a standard foam substrate and a standard cover fabric. The interior fire barrier material and standard cover fabric can be with or without stitched seams

10) (c) *Significance and use.* This test method is designed to measure the resistance of an interior fire barrier material and any associated seams to a smoldering ignition source when the barrier and/or seams is placed between a standard cover fabric and a standard foam substrate.

11) (g) *Standard cover fabric.* (1) The standard cover fabric represents a smolder-prone fabric and any associated sewn seams. Use the standard cover fabric specified in subpart C of this part.

12) (5) At 45 minutes, if the mockup assembly is smoldering or if stitched seams have ruptured, record a failure for the mockup and extinguish with appropriate means and proceed to paragraph (m) of this section. See Subparts C and D of this part.

13) (n) Pass/fail criteria. (1) The sample passes the requirements of this test procedure if the following criteria are met:

- (i) ok as written
- (ii) ok as written
- (iii) No stitched seam has failed with rupture from melting or burning.

14) The interior fire barrier material to be tested is placed between a standard cover fabric and a standard foam substrate and assembled on a metal frame. The interior fire barrier material and standard cover fabric can be with or without stitched seams

15) (c) *Significance and use.* This test method is designed to measure the resistance of an interior fire barrier material and any associated seams to an open flame ignition source when the barrier and/or seams is placed between a standard cover fabric and a standard foam substrate.

16) (iii) Terminate a test run if any of the following conditions occurs:

- (A) The mockup self-extinguishes;
- (B) The 45 minute test duration has elapsed;
- (C) A stitched seam ruptures; or
- (D) The mass of the mockup reaches more than 20% mass loss of the initial mass before 45 minutes have elapsed.

Sincerely,



Chris Smith  
Director of Governmental Affairs, CNA  
Coats North America



# Federal Register

---

Tuesday,  
March 4, 2008

---

## Part II

### Consumer Product Safety Commission

16 CFR Part 1634  
Standard for the Flammability of  
Residential Upholstered Furniture;  
Proposed Rule

In accordance with the National Environmental Policy Act ("NEPA"), the Executive Director of CPSC has issued a Finding of No Significant Impact ("FONSI") for the proposed upholstered furniture flammability standard. The FONSI is based on the staff's Environmental Assessment and concludes that there will be no significant impacts on the quality of the human environment as a result of the proposed upholstered furniture flammability standard. The Commission requests comments on both the Environmental Assessment and the FONSI.<sup>93</sup>

#### L. Executive Order 12988

According to Executive Order 12988 (February 5, 1996), agencies must state the preemptive effect, if any, of new regulations. The preemptive effect of this proposed regulation is as stated in section 16 of the FFA, 15 U.S.C. 1203(a).

#### M. Effective Date

The Commission proposes that the rule would become effective one year from publication of a final rule in the **Federal Register** and would apply to upholstered furniture manufactured on or after that date. The Commission believes that a one-year effective date should allow sufficient time for manufacturers to develop products for nationwide markets that will meet the proposed requirements. The Commission requests comments, especially from small businesses, on the proposed effective date and the impact it would have.

#### N. Proposed Findings

1. *General.* In order to issue a flammability standard under the FFA, the Commission must make certain findings and include these in the regulation, 15 U.S.C. 1193(j)(2). These findings are discussed in this section.

2. *Voluntary standards.* In the 1970s the Upholstered Furniture Action Council (UFAC) developed a voluntary industry program to assess the cigarette ignition propensity of upholstered furniture. The substance of the UFAC tests was then adopted in the ASTM E-1353 test method. CPSC staff estimates that approximately 90% of furniture production conforms to the UFAC voluntary program/ASTM E-1353 standards. However, while fire losses from cigarette-ignited upholstered furniture fires have been declining, a large number of deaths (260 annually)

and injuries (320 annually) over the period 2002–2004 that could be addressed by the proposed rule remain. Moreover, CPSC laboratory testing has found that UFAC-conforming furniture can nevertheless ignite and burn when exposed to smoldering cigarettes. The Commission is unaware of any other adopted and implemented voluntary standards that address the risk of fire from upholstered furniture ignitions. Accordingly, the Commission finds that compliance with any adopted and implemented voluntary upholstered furniture flammability standard is not likely to result in the elimination or adequate reduction of the risk of injury from such fires.

3. *Relationship of benefits to costs.* The Commission estimates the potential discounted benefits of a year's production of upholstered furniture complying with the standard to range from about \$419 million to \$424 million (based on a 3 percent discount rate). Compliance costs range from an estimated \$34 million to \$59 million annually. Thus, projected net benefits of the proposed standard range from \$363 million to \$385 million. On this basis, the Commission finds that the expected benefits from the regulation bear a reasonable relationship to its costs.

4. *Least burdensome requirement.* The Commission considered proposing the following alternatives: the staff's 2005 draft standard, the staff's 2001 draft small open flame standard, revised requirements drafted by California, a rule based on the industry's voluntary program, and a "no action" alternative under which the status quo would continue to prevail. Although the staff's 2005 draft standard could result in substantial net benefits, it would impose significantly higher costs and would necessitate the increased use of FR chemicals. While the staff's 2001 draft small open flame standard would likely be more effective in reducing small open flame fire losses, it would also impose greater costs and necessitate an increase in FR chemicals (nearly 66 percent of upholstery covers would likely need to receive FR treatments to pass). A proposal based on California's TB 117 requirements, which contains provisions for both fabrics and filling materials, would likely have substantial annual costs (about \$370 million) and would result in significantly lower net benefits (about \$190 million) than the proposed standard. The fact that significant levels of annual deaths and injuries remain despite the existence of the voluntary standard and a high level of compliance with it demonstrate that both the alternatives of a rule based on the voluntary standard and the no

action alternative are unlikely to result in adequate reduction or elimination of the risk. Therefore, the Commission finds that the proposed upholstered furniture flammability standard is the least burdensome requirement that would prevent or adequately reduce the risk of injury for which the regulation is being promulgated.

#### O. Conclusion

For the reasons stated in this preamble, the Commission preliminarily finds that a flammability standard for upholstered furniture is needed to adequately protect the public against the unreasonable risk of the occurrence of fire leading to death, injury, and significant property damage. The Commission also preliminarily finds that the standard is reasonable, technologically practicable, and appropriate. The Commission further finds that the standard is limited to the fabrics, related materials and products which present such unreasonable risks.

#### List of Subjects in 16 CFR Part 1634

Consumer protection, Flammable materials, Labeling, Upholstered furniture, Upholstered furniture materials, Records, Textiles, Warranties.

For the reasons stated in the preamble, the Commission proposes to amend Title 16 of the Code of Federal Regulations by adding part 1634 to read as follows:

#### PART 1634—STANDARD FOR THE FLAMMABILITY OF UPHOLSTERED FURNITURE AND UPHOLSTERED FURNITURE MATERIALS

##### Subpart A—General, Definitions, Performance Requirements

Sec.	
1634.1	Purpose, scope and effective date.
1634.2	Definitions.
1634.3	General requirements.
1634.4	Upholstery cover fabric smoldering ignition resistance test.
1634.5	Interior fire barrier material smoldering ignition resistance test.
1634.6	Interior fire barrier material open flame ignition resistance test.

##### Subpart B—Requirements Applicable to Manufacturers, Labeling, Guaranties

1634.7	Requirements applicable to upholstered furniture material manufacturers.
1634.8	Labeling.
1634.9	Requirements applicable to guaranties under Section 8 of the FFA, 15 U.S.C. § 1197.

<sup>93</sup> Both of these documents are available from the Commission's Office of the Secretary (see ADDRESSES section above) or from the Commission's Web site at: <http://www.cpsc.gov/library/foia/foia08/brief/briefing.html>.

### Subpart C—Test Apparatus and Materials for Smoldering Ignition Resistance Tests

- 1634.10 Test room.
- 1634.11 Specimen holder.
- 1634.12 Ignition source.
- 1634.13 Shooting material.
- 1634.14 Standard polyurethane foam substrate.
- 1634.15 Standard cotton velvet cover fabric.
- 1634.16 Conditioning.

### Subpart D—Test Facility, Exhaust System, and Cautions

- 1634.17 Test facility and exhaust system.
- 1634.18 Cautions.

### Subpart E—Test Facility and Materials for Open Flame Ignition Resistance Tests

- 1634.19 Test room.
- 1634.20 Butane gas flame ignition source.
- 1634.21 Metal test frame.
- 1634.22 Standard rayon cover fabric.
- 1634.23 Open flame tests fabric cut-out dimensions.
- 1634.24 Standard polyurethane foam substrate.
- 1634.25 Conditioning.

### Subpart F—Reupholstering

- 1634.26 Requirements applicable to reupholstering.

### Figures

- Figure 1 to Part 1634—Cigarette Ignition Specimen Holder—Base
- Figure 2 to Part 1634—Cigarette Ignition Specimen Holder—Movable Horizontal Support Panel
- Figure 3 to Part 1634—Mockup Assembly for Upholstery Cover Fabric Smoldering Ignition Resistance Test
- Figure 4 to Part 1634—Mockup Assembly for Interior Fire Barrier Material Smoldering Ignition Resistance Test
- Figure 5 to Part 1634—Cut-Out Template Dimensions for Open Flame Test
- Figure 6 to Part 1634—Open Flame Metal Test Frame
- Figure 7 to Part 1634—Mockup Assembly for Interior Fire Barrier Materials Open Flame Ignition Resistance Test

Authority: 15 U.S.C. 1193.

### Subpart A—General, Definitions, Performance Requirements

#### § 1634.1 Purpose, scope, and effective date.

(a) *Purpose.* This part 1634 establishes flammability limits that all upholstered furniture subject to this part must meet before sale or introduction into commerce. The purpose of these requirements is to reduce deaths and injuries associated with upholstered furniture fires.

(b) *Scope.* All upholstered furniture as defined in § 1634.2(a) manufactured or

reupholstered on or after the effective date of this standard is subject to the requirements of this part.

(c) *Effective date.* The standard shall become effective on [the effective date of this standard] and shall apply to all upholstered furniture, as defined in 1643.2(a), manufactured or reupholstered on or after that date.

#### § 1634.2 Definitions.

In addition to the definitions given in section 2 of the Flammable Fabrics Act as amended (15 U.S.C. 1191), the following definitions apply for purposes of this part 1634.

(a) *Upholstered furniture* means, for purposes of this part 1634, an article of seating furnishing intended for indoor use in a home or other residential occupancy that: consists in whole or in part of resilient cushioning materials (such as foam, batting, or related materials) enclosed within a covering consisting of fabric or related materials, such as leather; and is constructed with contiguous upholstered seat and back or arms(s).

(1) Items included in the scope of paragraph (a) of this section include, but are not limited to, products that are intended or promoted for indoor residential use for sitting or reclining upon, such as: chairs, sofas, motion furniture, sleep sofas, home office furniture customarily offered for sale through retailers or otherwise available for residential use, and upholstered furniture intended for use in dormitories or other residential occupancies. This includes the unattached cushions or pillows on such items if they are sold with the item of upholstered furniture.

(2) Items excluded from the scope of paragraph (a) of this section consist of: furniture, such as patio chairs, intended solely for outdoor use; furniture without contiguous upholstered seating and backs and/or arm surfaces, such as ottomans; pillows or pads that are not sold with an article of furniture; commercial or industrial furniture not offered for sale through retailers or not otherwise available for residential use; furniture intended or sold solely for use in hotels and other short-term lodging and hospitality establishments; futons, flip chairs, the mattress portions of sleep sofas; and infant or juvenile products such as walkers, strollers, high chairs, or pillows.

(b) *Type I upholstered furniture* means upholstered furniture that is constructed with an upholstery cover fabric or other material that covers the seating area and is certified to meet the performance requirements of § 1634.4.

(c) *Type II upholstered furniture* means upholstered furniture that is constructed with an interior fire barrier material that:

(1) Is located directly beneath the external covering material;

(2) Completely encases the filling material used in the seating area of the item of upholstered furniture; and

(3) Is certified to meet the performance requirements of §§ 1634.5 and 1634.6.

(d) *Manufacturer* means any entity that produces or reupholsters upholstered furniture or manufactures upholstered furniture materials subject to this part 1634. For purposes of this part, an importer of upholstered furniture is also a manufacturer. See subpart F of this part for additional information on reupholstering.

(e) *Produced* means, for the purposes of this part 1634, manufactured or imported.

(f) *Upholstery cover fabric* means the outermost layer of attached fabric or other material, such as leather, used to cover the seating area of the upholstered furniture item.

(g) *Crevise* means the location in the mockup formed by the intersection of the vertical and horizontal surfaces of the test mockup.

(h) *Interior fire barrier* means a fire-resistant material which is interposed between the upholstery cover fabric and any interior filling material.

(i) *Fire-resistant material* means a material capable of reducing the likelihood of ignition or delaying fire growth.

(j) *Flame retardant* means having a chemical coating or treatment added that imparts greater fire resistance.

(k) *Ignition* (for open flame testing) means continuous, self-sustaining combustion, characterized by the presence of any visible flaming, glowing, or smoldering, after removal of the ignition source.

(l) *Metal test frame* means the apparatus consisting of two rectangular metal frames used for assembly of seating area mockups in open flame ignition resistance tests. See subpart E of this part.

(m) *Mockup assembly* means the seating area mockup consisting of the component material to be evaluated and all required standard test materials, fully assembled in the appropriate specimen holder or metal test frame.

(n) *Sample* means a material to be tested for use in upholstered furniture subject to this part.

(o) *Seating area* means those portions of an item of upholstered furniture which a person may sit upon, or rest against while sitting, including the seat

and the inside of the back and arms of the item. The seating area includes such surfaces of any loose pillows or cushions that are not attached to the item of upholstered furniture but are sold with it.

(p) *Self-extinguishment* means the unassisted termination of any visible combustion within a defined time period after ignition source removal and before the specimen is completely consumed.

(q) *Sheeting material* means cotton sheeting fabric used to cover the cigarette ignition source in smoldering ignition resistance tests. See subpart C of this part.

(r) *Smolder* means combustion characterized by smoke production, without visible flame or glowing.

(s) *Specimen* means an individual piece of upholstery fabric or barrier material, as defined in paragraph (n) of this section, used in a mockup assembly for smoldering or open flame ignition testing.

(t) *Specimen holder* means the two wooden panels used for assembly of seating area mockups in smoldering ignition resistance tests. See subpart C of this part.

(u) *Standard polyurethane foam (SPUF) substrate* means the standard substrate used for the assembly of seating area mockups to evaluate materials used in upholstered furniture construction. See subparts C and E of this part.

(v) *Substrate* means the innermost material of the tested seating area mockup, representing the filling material used in upholstered furniture.

(w) *Warp or machine direction of the fabric* means the direction of yarns that run lengthwise, i.e., parallel to selvage in woven fabrics.

#### § 1634.3 General requirements.

(a) *Upholstered furniture*. Each item of upholstered furniture subject to this part shall comply with the performance requirements of this part applicable to the upholstered furniture materials required for that "Type" of upholstered furniture and all other applicable requirements of this part.

(b) *Guaranties*. Each guaranty issued under this part shall be in accordance with the applicable requirements of § 1634.9.

(c) *Summary of § 1634.4 through § 1634.6 tests*. The test methods set forth in §§ 1634.4 through 1634.6 measure the flammability performance (resistance to smoldering or small open flame ignition) of cover fabrics and fire barrier materials through a series of tests using small scale mockups representative of

the typical construction of upholstered furniture.

(d) *Standard cover fabric cutting—(1) Smoldering test*. The vertical panel pieces shall be cut with the long dimension being in the warp direction and the top edge is defined such that the pile lays smooth when brushed from top to bottom. The horizontal panel pieces shall be cut with the long dimension being in the warp direction and the top edge is defined such that the pile lays smooth when brushed from top to bottom.

(2) *Open flame test*. The open flame test specimens shall be cut with the long dimension being in the warp direction (if applicable).

#### § 1634.4 Upholstery cover fabric smoldering ignition resistance test.

(a) *Scope*. This test method is intended to measure the cigarette ignition resistance of upholstery cover fabrics used in upholstered furniture. This test applies to all upholstery cover fabrics to be used in Type I upholstered furniture.

(b) *Summary of test method*. Ten initial test specimens are required for the upholstery cover fabrics sample. Vertical and horizontal panels of a standard foam substrate are covered, using the upholstery cover fabric to be tested. These panels are placed in the specimen holders, and a lighted cigarette is placed in the crevice formed by the intersection of vertical and horizontal panels of each test assembly. Each cigarette is covered with a piece of sheeting fabric. The cigarettes are allowed to burn their entire length. Test measurements and observations are recorded during and after the 45-minute test duration. The mockup must not continue to smolder at the end of the test or transition to flaming at any time during the test, and the substrate must not exceed the mass loss limit. If the 10 initial specimens meet the performance criteria in paragraph (m) of this section, the cover fabric sample passes. If a failure is recorded in any of the 10 initial specimens, the test shall be repeated on an additional 20 specimens. At least 25 of the 30 specimens tested must meet the performance criteria of paragraph (m) of this section.

(c) *Significance and use*. This test method is designed to measure the resistance of an upholstery cover fabric to a smoldering ignition source when the fabric is placed over a standard polyurethane foam substrate.

(d) *Test apparatus and materials*. The test apparatus and materials used in this test are detailed in subpart C of this part.

(e) *Ignition source*. The ignition source is the standard cigarette specified in subpart C of this part.

(f) *Sheeting material*. Sheeting material shall be used to cover the standard test cigarettes. For testing, the fabric shall be cut into squares 127 × 127 mm (5.0 × 5.0 in). Use the sheeting material specified in subpart C of this part.

(g) *Standard polyurethane foam substrate*. Upholstery cover materials shall be tested in a specimen holder using standard polyurethane foam (SPUF) substrate. Use the SPUF substrate specified in subpart C of this Part.

(1) The SPUF substrate shall be cut into 203 × 203 × 76 mm (8.0 × 8.0 × 3.0 in) pieces for vertical panels and 127 × 203 × 76 mm (5.0 × 8.0 × 3.0 in) pieces for horizontal panels.

(2) Each SPUF substrate piece shall be hand crushed before use by wadding or balling up one time in the fist.

(3) On the data sheet, record the initial mass of each horizontal and vertical SPUF substrate piece to the nearest 0.1 grams.

(h) *Specimen holder*. The specimen holder shall consist of two wooden panels, each a nominal 203 × 203 mm (8.0 × 8.0 in) and nominal 19 mm (0.75 in) thickness, joined together at one edge. A moveable horizontal panel support shall be positioned on a centrally located guide. See subpart C and Figures 1 and 2.

(i) *Test facility and cautions*. The test facility, exhaust system, and cautions are detailed in subpart D of this part.

(j) *Conditioning*. All test specimens and standard test materials (including SPUF substrates, cigarettes, and sheeting material) shall be conditioned in accordance with subpart C of this part.

(k) *Test specimens—(1) Specimen requirements*. (i) From the upholstery cover fabric sample to be tested, initially 10 specimens shall be cut, comprised of vertical panels, each 203 × 432 mm (8.0 × 17.0 in), and horizontal panels, each 203 × 280 mm (8.0 × 11.0 in).

(ii) The vertical and horizontal panel cover fabric pieces shall be cut with the long dimension in the warp direction and such that the major areas of fabric variation will lie in the crevice of the mockup assembly.

(iii) The horizontal panel cover fabric pieces shall be mounted warp to warp with the vertical panel pieces such that the major areas of fabric variation will lie in the crevice of the mockup assembly.

(2) *Specimen mounting*. (i) For vertical panels, place the cover fabric on the 203 × 203 × 76 mm (8.0 × 8.0 × 3.0

in) SPUF substrate pieces, taking care that any areas of fabric variation mentioned in paragraph (k)(1) of this section are positioned such that they will form the crevice of the assembled mockup. The warp or machine direction of the fabric should run front to back on the mockup assembly. Attach the cover fabric to the SPUF substrate pieces with straight pins and pull the cover fabric smooth so that no air gaps exist between the fabric and SPUF substrate. Attach the cotton sheeting material to the vertical panels with straight pins so that the sheeting material will cover the cigarette when placed in the crevice, approximately 50 mm (2 in) from the top of the 203 mm (8.0 in) dimension.

(ii) For horizontal panels, place the cover fabric on the 127 x 203 x 76 mm (5.0 x 8.0 x 3.0 in) SPUF substrate pieces, taking care that any areas of fabric variation mentioned in paragraph (k)(1) of this section are on the edge which will form the crevice of the assembled mockup. The warp direction of the cover fabric shall run front to back on the mockup assembly. Attach the cover fabric to the SPUF substrate pieces with straight pins and pull the fabric smooth so that no air gaps exist between the fabric and foam substrate.

(iii) Place the assembled vertical and horizontal panels in the specimen holder. Press the horizontal panel against the vertical panel to create a straight-line crevice at the intersection. See Figure 3.

(1) *Test procedure.* (1) Place the assembled mockups a sufficient distance apart from each other to avoid heat transfer between samples.

(2) Light cigarettes so that no more than 4 mm (0.16 inch) is burned away and place one cigarette on each mockup crevice created by the intersection of the vertical and horizontal panels, such that the cigarette contacts both surfaces and is equidistant from the side edges of the test panels.

(3) Immediately after placement in the crevice of each mockup, cover cigarettes with cotton sheeting and run one finger over the sheet along the length of the covered cigarette to ensure good cover sheeting-to-cigarette contact and begin timer. If a test is inadvertently interrupted or a cigarette self-extinguishes on lighting, it shall be repeated from the beginning with a new cigarette.

(4) Continue testing for 45 minutes.

(5) At 45 minutes, if the mockup assembly is smoldering, record a failure for the mockup and extinguish with appropriate means and proceed to paragraph (m) of this section. See Subparts C and D of this part.

(6) Remove cotton sheeting fabric and remains of upholstery fabric from the substrate pieces.

(7) Carefully remove the SPUF substrate pieces, clean all carbonaceous char from panels with a brush.

(8) If the application of an extinguishing agent was not necessary or a gaseous extinguishing agent (e.g., carbon dioxide or nitrogen) was applied to the SPUF substrate, record the mass of the un-charred portions of the SPUF substrate pieces to the nearest 0.1 grams within 15 minutes and proceed to paragraph (n) of this section.

(m) *Pass/fail criteria.* (1) The sample passes the requirements of this test procedure if the following criteria are met:

(i) No mockup continues to smolder after the 45 minute test duration;

(ii) No mockup transitions to open flaming; and

(iii) No SPUF substrate (i.e., sum of both horizontal and vertical pieces) of any mockup assembly has more than 10% mass loss.

(2) If the 10 initial specimens meet the performance criteria of this paragraph (m), the cover fabric sample passes. If a failure is recorded in any of the 10 initial specimens, the test shall be repeated on an additional 20 specimens. At least 25 of the 30 specimens tested must meet the criteria of this paragraph.

(n) *Test report.* The test report shall include, at a minimum, the following information:

(1) Name and address of test laboratory;

(2) Date of the test(s);

(3) Name of the operator conducting the test;

(4) Complete description of the test specimens;

(5) Applicable smoldering and mass and data for each SPUF substrate piece from each mockup including:

(i) Mockup smoldering at 45 minutes (Yes/No);

(ii) Pre-test mass;

(iii) Post-test mass; and

(iv) The percent mass loss of the SPUF substrate of each mockup assembly.

(6) Statement of overall pass/fail results.

#### § 1634.5 Interior fire barrier material smoldering ignition resistance test.

(a) *Scope.* This test method is intended to measure the cigarette ignition resistance of interior fire barrier materials used in upholstered furniture to be used in Type II upholstered furniture. This test method applies to fire-resistant materials including, but not limited to, all interior fabrics or high loft battings to be qualified as fire barriers.

(b) *Summary of test method.* Ten initial test specimens are required for the interior fire barrier sample. Vertical and horizontal panels of the interior fire barrier material to be tested are placed between a standard foam substrate and a standard cover fabric. The panels are placed in the specimen holders and a lighted cigarette is placed in the crevice formed by the intersection of the vertical and horizontal panels in each test assembly. Each cigarette is covered with a piece of sheeting fabric. The cigarettes are allowed to burn their full length. Test measurements and observations are recorded during and after the 45-minute test duration. The substrate must not exceed the mass loss limit at the end of the test and the mockup assembly must not transition to open flaming at anytime during the test. If the initial 10 specimens meet the performance criteria in paragraph (n) of this section, the interior fire barrier sample passes. If a failure is recorded in any of the 10 initial specimens, the test shall be repeated on an additional 20 specimens. The performance criteria of paragraph (n) of this section must be met on at least 25 of the 30 specimens tested.

(c) *Significance and use.* This test method is designed to measure the resistance of an interior fire barrier material to a smoldering ignition source when the barrier is placed between a standard cover fabric and a standard foam substrate.

(d) *Test apparatus and materials.* The test apparatus and materials are detailed in subpart C of this part.

(e) *Ignition source.* The ignition source is the standard cigarette specified in subpart C of this part.

(f) *Sheeting material.* Sheeting material shall be used to cover the standard test cigarettes. For testing, the fabric shall be cut into squares 127 x 127 mm (5.0 x 5.0 in). Use the sheeting material specified in subpart C of this part.

(g) *Standard cover fabric.* (1) The standard cover fabric represents a smolder-prone fabric. Use the standard cover fabric specified in subpart C of this part.

(2) From the standard cover fabric, initially 10 pieces shall be cut for vertical panels each 203 x 432 mm (8.0 x 17.0 in) and initially 10 pieces for horizontal panels each 203 x 280 mm (8.0 x 11.0 in).

(h) *Standard polyurethane foam substrate.* (1) Fire barrier materials shall be tested in a specimen holder using standard polyurethane foam (SPUF) substrate. Use the SPUF substrate specified in subpart C of this part.

(2) The SPUF substrate shall be cut into pieces 203 x 203 x 76 mm (8.0 x 8.0 x 3.0 in) for vertical panels and 127 x 203 x 76 mm (5.0 x 8.0 x 3.0 in) for horizontal panels.

(3) Each SPUF substrate piece shall be hand crushed before use by wadding or balling up one time in the fist.

(4) Record the initial mass to the nearest 0.1 grams of each horizontal and vertical SPUF substrate piece in the data sheet.

(i) *Specimen holder.* The specimen holder shall consist of two wooden panels, each a nominal 203 x 203 mm (8.0 x 8.0 in) and nominal 19 mm (0.75 in) thickness, joined together at one edge. A moveable horizontal panel support is positioned on a centrally located guide. See subpart C and Figures 1 and 2.

(j) *Test facility and cautions.* The test facility, exhaust system, and cautions are detailed in subpart D of this part.

(k) *Conditioning.* All test specimens and standard test materials (including SPUF substrates, cigarettes, and sheeting material) shall be conditioned in accordance with subpart C of this part.

(l) *Test specimens—(1) Test specimen requirements.* From the interior fire-barrier material sample to be tested, initially 10 specimens shall be cut, comprised of vertical panels each 203 x 356 mm (8.0 x 14.0 in) and horizontal panels each 203 x 229 mm (8.0 x 9.0 in). If the interior fire-barrier material is directional, the vertical panel pieces shall be cut with the long dimension being in the warp direction. The horizontal panel specimens shall be cut such that the short dimension is in the warp direction.

(2) *Specimen mounting.* (i) For vertical panels, place the 203 x 432 mm (8.0 x 17.0 in) standard cover fabric over the fire-barrier material on a 203 x 203 x 76 mm (8.0 x 8.0 x 3.0 in) SPUF substrate piece. The standard cover fabric and interior fire-barrier shall be oriented such that the top edges of these materials run from top to bottom. Attach with straight pins and pull smooth so that no air gaps exist. Attach the cotton sheeting material to the vertical panels with straight pins so that the sheeting material will cover the cigarette when placed in the crevice, approximately 50 mm (2.0 in) from the top of the panel.

(ii) For horizontal panels, place the 203 x 280 mm (8.0 x 11.0 in) standard cover fabric over the interior fire-barrier on the 127 x 203 x 76 mm (5.0 x 8.0 x 3.0 in) SPUF substrate pieces. The standard cover fabric and interior fire-barrier shall be oriented such that the top edges of these materials run from the crevice to the front. Attach with

straight pins and pull smooth so that no air gaps exist.

(iii) Place the assembled vertical and horizontal panels in the specimen holders. Press the horizontal panel against the vertical panel to create a straight-line crevice at the intersection. See Figure 4.

(m) *Test procedure.* (1) Place the assembled mockups a sufficient distance apart from each other to avoid heat transfer between samples.

(2) Light cigarettes so that no more than 4 mm (0.16 inch) is burned away and place one cigarette on each mockup crevice created by the intersection of the vertical and horizontal panels, such that the cigarette contacts both surfaces and is equidistant from the side edges of the test panels.

(3) Immediately after placement in the crevice of each mockup, cover cigarettes with cotton sheeting and run one finger over the sheet along the length of the covered cigarette to ensure good cover sheeting-to-cigarette contact and begin timer. If a test is inadvertently interrupted or cigarette self extinguishes on lighting, it shall be repeated from the beginning with a new cigarette.

(4) Continue testing for 45 minutes.

(5) At 45 minutes, if the mockup assembly is smoldering, extinguish with appropriate means. See subparts C and D of this part.

(6) Remove cotton sheeting fabric, remains of standard cover fabric, and interior fire-barrier material from the substrate panels.

(7) Carefully remove the SPUF substrate test panels and clean all carbonaceous char from panels with a brush.

(8) If the mockup has self-extinguished by the end of the 45 minute test, or if a gaseous extinguishing agent (e.g. carbon dioxide or nitrogen) was applied to the mockup, record the mass of the un-charred portions of the SPUF substrate pieces to the nearest 0.1 grams within 15 minutes and proceed to § 1634.5(n).

(9) If a mass-adding extinguishing agent (e.g., water-based agent) was applied to the substrate, re-condition the SPUF substrate pieces as follows.

(i) Place the SPUF substrate pieces in the active flow of a laboratory air hood to dry for at least 24 hours.

(ii) Measure and record the mass of the SPUF substrate pieces to the nearest 0.1 gram.

(iii) Place the SPUF substrate pieces in the active flow of the laboratory air hood to dry for at least three additional hours.

(iv) Measure and record the mass of the SPUF substrate pieces to the nearest

0.1 gram and compare the measurement with the previous one.

(v) Repeat this procedure every three hours until the mass of the substrate pieces remains within a tolerance of 0.5% from the previous reading.

(vi) Re-condition the SPUF pieces according to paragraph (k) of this section.

(vii) Record the mass of the un-charred portions of the SPUF substrate pieces to the nearest 0.1 grams.

(n) *Pass/fail criteria.* (1) The sample passes the requirements of this test procedure if the following criteria are met:

(i) No SPUF substrate (i.e., sum of both horizontal and vertical pieces) of any specimen from a mockup assembly has more than 1% mass loss; and

(ii) No mockup assembly transitions to open flaming.

(2) If the 10 initial specimens meet the performance criteria of this paragraph (n), the interior fire-barrier sample passes. If a failure is recorded in any of the 10 initial specimens, the test shall be repeated on an additional 20 specimens. At least 25 of the 30 specimens tested must meet the performance criteria of this paragraph (n).

(o) *Test report.* The test report shall include, at a minimum, the following information:

(1) Name and address of test laboratory;

(2) Date of the test(s);

(3) Name of the operator conducting the test;

(4) Complete description of the test specimens;

(5) Mass data for each SPUF substrate piece from each mockup including:

(i) Pre-test mass;

(ii) Post-test mass; and

(iii) The percent mass loss of the SPUF substrate of each mockup assembly.

(6) Statement of overall pass/fail results.

#### § 1634.6 Interior fire barrier material open flame ignition resistance test.

(a) *Scope.* This test procedure is intended to measure the open flame ignition resistance of interior fire-barrier materials to be used in Type II upholstered furniture. This test applies to materials including, but not limited to, interior fabrics or high loft battings to qualify them as fire-barriers.

(b) *Summary of test method.* Ten initial test specimens are required for the interior fire-barrier sample. The interior fire-barrier material to be tested is placed between a standard cover fabric and standard foam substrate and assembled on a metal test frame. An

open flame ignition source is applied to the crevice formed by the intersection of the seat/back surfaces of the mockup. Test measurements and observations are recorded during the 45-minute test duration. The mockup assembly must not exceed the mass loss limit. If the 10 initial specimens meet the performance criteria of paragraph (n) of this section, the interior fire-barrier sample passes. If a failure is recorded in any of the 10 initial specimens, the test shall be repeated on an additional 20 specimens. At least 25 of the 30 specimens tested must meet the performance criteria of paragraph (n) of this section.

(c) *Significance and use.* This test method is designed to measure the resistance of an interior fire-barrier material to an open flame ignition source when the barrier is placed between a standard cover fabric and a standard foam substrate.

(d) *Test apparatus and materials.* The test apparatus and materials are detailed in subpart E of this part.

(e) *Ignition source.* The ignition source is the nominal 240 mm butane gas flame described in subpart E of this part.

(f) *Standard cover fabric.* (1) The standard cover fabric represents a moderately flammable upholstery cover fabric. Use the standard cover fabric specified in subpart E of this part.

(2) The standard cover fabric size needed for each test is 1020 x 700 ± 10 mm (40 x 27.5 ± 0.4 in). From the standard cover fabric, cut triangular cut-outs centered 575 mm (22.5 in) from the top edge on both sides. The size of these cut-outs shall be approximately 55 x 135 ± 5 mm (2.1 x 5.25 ± 0.2 in) high. See subpart E of this part and Figure 5.

(g) *Standard polyurethane foam substrate.* (1) Interior fire-barrier materials shall be tested with a standard polyurethane foam (SPUF) substrate. Use the SPUF substrate specified in subpart E of this part.

(2) Two panels of the SPUF substrate shall be used. The vertical (back) block shall be 457 x 305 ± 5 mm (18.0 x 12.0 ± 0.2 in) x 76 ± 2 mm (3.0 ± 0.08 in) thick. The horizontal (seat) block shall be 457 x 83 ± 5 mm (18.0 x 3.25 ± 0.2 in) x 76 ± 2 mm (3.0 ± 0.08 in) thick.

(h) *Metal test frame.* The metal test frame shall consist of two rectangular metal frames locked at right angles to each other. A rod shall be continuous across the back of the metal test frame. See subpart E of this part and Figure 6.

(i) *Test facility and cautions.* The test facility, exhaust system and cautions are detailed in subpart D of this part.

(j) *Conditioning.* All test specimens and standard test materials shall be

conditioned in accordance with subpart E of this part.

(k) *Test specimens.* (1) The interior fire-barrier specimen needed for each test is 1020 x 700 ± 10 mm (40 x 27.5 ± 0.4 in). From the interior fire-barrier specimen, cut triangular cut-outs centered 575 mm (22.5 in) from the top edge on both sides. The size of these cut-outs shall be approximately 55 x 135 ± 5 mm (2.1 x 5.25 ± 0.2 in) high. See subpart E of this part and Figure 5.

(2) If the interior fire-barrier material is directional, the specimen shall be cut with the long dimension (1020 mm, 40 in) being in the warp direction and the top edge is defined as appropriate.

(l) *Mockup assembly.* (1) Position the seat frame in the upright position. Adjust the horizontal and vertical (seat and back) panels by loosening the screws holding the two panels in place. Pull the horizontal panel forward and the vertical panel upwards creating a larger gap between the two panels at the crevice. Temporarily secure the two panels in place (expanded position).

(2) Lay the interior fire-barrier specimen flat and face up on the table. Lay the standard cover fabric on top, face up.

(3) Fold the two sides of the top (larger) section of fabric and fire-barrier specimen (from the cutout upwards) over the face of the standard cover fabric.

(4) Thread the folded standard cover fabric and fire-barrier specimen under the horizontal rod and pull them out from the back of the metal test frame until the cutouts are lined up with the horizontal rod.

(5) Thread the folded standard cover fabric and fire-barrier specimen back over the rod and pull them out from the front of the frame.

(6) Line up and pull both the top and bottom sections of the standard cover fabric and fire-barrier specimen so that the cutouts are lined up with the metal rod on both sides and the standard cover fabric and fire-barrier specimen are laying flat and free of folds and wrinkles.

(7) Place the larger SPUF block flush against the back metal frame and resting on the fire-barrier specimen. Loosen the screws holding the vertical (back) panel and lower the panel until the top of the panel is flush with the top of the larger SPUF foam block. Tighten the screws so that the vertical panel is secure.

(8) Lift the larger portion of both the fire-barrier specimen and standard cover fabric over the SPUF back block and secure them to the top of the back section of the metal frame using metal clips.

(9) Starting at the lowest part of the vertical section on one side, clip both the fire-barrier specimen and standard cover fabric to the frame. At the top corner, make a diagonal fold of the fire-barrier specimen separate from the standard cover fabric. Make a similar fold with the standard cover fabric and secure all the folded layers (both fire-barrier and standard cover fabric) to the frame with metal clips to the side of the test frame. Repeat for the other side.

(10) When the back section is completed, place the frame down so that the back of the frame is on the table.

(11) Lift up the smaller portion of the standard cover fabric and fire-barrier specimen and lay them flat on the back panel.

(12) Place the smaller SPUF block with the 83 mm (3.25 in) side flush against the seat section of the metal frame and press against the back panel. Loosen the screw holding the horizontal panel and move the panel until the panel is flush with the smaller SPUF foam block. Tighten the screws so that the horizontal panel is secure.

(13) Pull the smaller section of the fire-barrier specimen and standard cover fabric over the SPUF seat block and secure them to bottom front edge of the metal frame using metal clips.

(14) Re-position the assembly in the upright position.

(15) On one side, fold the unsecured front edge of the fire-barrier specimen back against the SPUF block. Then, make a diagonal fold with the unsecured top edge of fire-barrier specimen down on top of it. Repeat with the unsecured edges of standard cover fabric and clip to the bottom of the metal test frame. Repeat on the other side.

(16) Ensure that the standard cover fabric and fire-barrier specimens are smooth and under uniform tension at all locations to eliminate air gaps between the standard cover fabric, fire-barrier specimen, and the SPUF blocks. Do not allow a gap exceeding 3 mm (0.125 inch) along the seat/back crevice. See Figure 7.

(m) *Test procedure.* Have a means for extinguishing the specimen close at hand. A hand-held carbon dioxide extinguisher is adequate for most specimens; however, a water spray system should be available as a back-up, in case the carbon dioxide fails to completely extinguish the fire.

(1) *Pretest.* (i) Tare the scale with the empty metal test frame and clips or, if the scale does not have tare capability, record the mass of metal test frame and clips.



(ii) Assemble the mockup as described in paragraph (l) of this section.

(iii) Record the initial mass of the fabric/specimen/substrate assembly directly (if tared) or by subtraction (if not tared).

(iv) Calculate and record the mass corresponding to 20% mass loss of initial mass of the mockup assembly.

(2) *Lighting the igniter flame.* (i) Open the butane tank slowly and light the end of the burner tube. Adjust the gas flow to the appropriate rate to achieve a 24C mm flame. See subpart E of this part.

(ii) Allow the flame to stabilize for at least 2 minutes.

(3) *Starting and performing the test.*

(i) Place the lit burner tube in the crevice of the mockup so that the end of the igniter is at the center of the mockup equidistant from either edge.

(ii) Apply the flame for  $70 \pm 1$  seconds, then immediately remove ignition source from the mockup. Observe the mockup combustion behavior for 45 minutes.

(iii) Terminate a test run if any of the following conditions occurs:

(A) The mockup self-extinguishes;

(B) The 45 minute test duration has elapsed; or

(C) The mass of the mockup reaches more than 20% mass loss of the initial mass before 45 minutes have elapsed.

(n) *Pass/fail criterion.* (1) The sample passes if no mockup assembly has more than 20% mass loss at the end of the 45-minute test.

(2) If the 10 initial specimens meet the performance criterion, the interior fire-barrier sample passes. If a failure is recorded in any of the 10 initial specimens, the test shall be repeated on an additional 20 specimens. At least 25 of the 30 specimens tested must meet the performance criterion of this paragraph.

(o) *Test report.* The test report shall include, at a minimum, the following information:

(1) Name and address of the test laboratory;

(2) Date of the test(s);

(3) Name of operator conducting the test;

(4) Complete description of the test specimens;

(5) Mass data for the mockup including:

(i) Initial mass;

(ii) Mass corresponding to 20% mass loss of initial mass;

(iii) Time to reach the mass equal to 20% mass loss of the initial mass;

(iv) The percent mass loss of the mockup at 45 minutes.

(6) Statement of overall pass/fail results.

## Subpart B—Requirements Applicable to Manufacturers, Labeling, Guaranties

### § 1634.7 Requirements applicable to upholstered furniture manufacturers.

(a) *General.* Each manufacturer (including importers) of upholstered furniture subject to this part shall ensure that each article of upholstered furniture it manufactures or imports for introduction into commerce complies with all applicable requirements of this part.

(b) *Label.* Each article of upholstered furniture subject to this part shall bear a label conforming to the requirements of § 1634.8.

(c) *Certification.* The certification statement specified on the label required by paragraph (b) of this section constitutes the manufacturer's certification that the article of upholstered furniture to which it is affixed complies with all applicable requirements of this part.

(d) *Basis for certification.* The manufacturer shall have an objectively reasonable basis for the certification required by paragraph (c) of this section. Examples of an objectively reasonable basis for certification are:

(1) Records of reasonable and representative tests demonstrating compliance with all applicable requirements of this part for each cover or barrier material required for the Type of furniture specified on the label required by § 1634.8; or

(2) Possession of guaranties meeting the requirements of § 1634.9 for each cover or barrier material required for the Type of furniture specified on the label required by § 1634.8 and maintaining that the manufacturer has not, by further processing, negatively affected the fire performance of any such cover or barrier material.

(e) *Records.* (1) Every upholstered furniture manufacturer (including importers) subject to this part shall maintain records of the test results and details of each test performed by or for that manufacturer (including failures) intended to support certification in accordance with paragraph (c) of this section. Details shall include all the information required in the Test Report in accordance with §§ 1634.4(n), 1634.5(o) and 1634.6(o).

(2) Records required by this paragraph (e) shall be in English and kept at a location in the United States.

(3) Records required by this paragraph (e) shall be maintained by the manufacturer during production of the upholstered furniture and for a period of at least three (3) years after production of the article of upholstered furniture ceases. These records shall be made

available to Commission staff upon request.

(f) *Cessation of production.* If the manufacturer becomes aware of any information that indicates that any article of upholstered furniture manufactured by that manufacturer fails to comply with this part, the manufacturer shall cease production and distribution of such upholstered furniture until corrective action has been taken to ensure that further production will conform to all applicable requirements of this part.

(g) *Notification to upholstered furniture material suppliers.* An upholstered furniture manufacturer who becomes aware of information indicating that any cover or barrier material used, or intended to be used, in upholstered furniture produced by it fails to meet any applicable requirement of this part shall promptly inform the supplier of that material of the deficiency. (Upholstered furniture manufacturers are also reminded of the reporting requirements of § 15 of the Consumer Product Safety Act, 15 U.S.C. 2064, and implementing regulations at 16 CFR part 1115.)

### § 1634.8 Labeling.

(a) Each article of upholstered furniture subject to this part shall bear a permanent, conspicuous, and legible label containing:

(1) Name of the manufacturer (and importer, if any);

(2) Location of the manufacturer (and importer, if any), including street address, city and state;

(3) Month and year of manufacture;

(4) Model identification;

(5) Type identification (i.e., "Type I" or "Type II"); and

(6) The statement "The manufacturer hereby certifies that this article of upholstered furniture complies with all applicable requirements of 16 CFR part 1634".

(b) The information required by paragraph (a) of this section shall be set forth separately from any other information appearing on the label. Other information, representations, or disclosures, appearing on labels required by this section or elsewhere on the item, shall not interfere with, minimize, detract from, or conflict with, the required information.

(c) No person shall remove or mutilate, or cause or participate in the removal or mutilation of, any label required by this section to be affixed to any article of upholstered furniture.

**§ 1634.9 Requirements applicable to guaranties under section 8 of the FFA, 15 U.S.C. 1197.**

(a) *General.* Either the manufacturer of a finished article of upholstered furniture subject to this part or the manufacturer of any cover or barrier material subject to this part may issue a guaranty in accordance with this section. The guaranty shall specify the classification(s) (Type I or II) of upholstered furniture for which the guaranty is intended to be valid.

(b) *Tests to support guaranties.* Section 8 of the Flammable Fabrics Act, 15 U.S.C. 1197, requires that a guaranty thereunder ultimately be supported by reasonable and representative tests. Reasonable and representative tests for purposes of this part shall be tests performed sufficiently to demonstrate that the tested item conforms with each applicable requirement of this part.

**Subpart C—Apparatus and Materials for Smoldering Ignition Resistance Tests**

**§ 1634.10 Test room.**

(a) The test room shall have an appropriate fire protection, suppression system. A suitable extinguishment system such as a water bottle fitted with a spray nozzle shall be provided to extinguish any ignited portions of the mockup assembly. Dry chemical extinguishing agents shall not be used to extinguish or suppress smoldering combustion since the chemicals add mass therefore increasing the post-test mass of the mockup remains. In addition, straight pins, staples, a razor, knife or scissors, a scale, and a brush and/or tongs may be needed to perform the tests.

(b) If conditions in the test room do not meet the conditioning specifications, then testing must be initiated within 10 minutes after the specimens are removed from the conditioning room.

**§ 1634.11 Specimen holder.**

The specimen holder shall consist of two wooden panels, each nominal 203 x 203 mm (8.0 x 8.0 in) and nominal 19 mm (0.75 in) thickness, joined together at one edge. A moveable horizontal panel support is positioned on a centrally located guide. See Figures 1 and 2.

**§ 1634.12 Ignition source.**

The ignition source for all smoldering tests shall be cigarettes without filter tips made from natural tobacco,  $85 \pm 2$  mm ( $3.3 \pm 0.1$  in) long and with a packing density of  $0.27 \pm 0.02$  g/cm<sup>3</sup> ( $0.16 \pm 0.01$  oz/in<sup>3</sup>) and a total weight of  $1.1 \pm 0.1$  g ( $0.039 \pm 0.004$  oz).

**§ 1634.13 Sheetting material.**

(a) The specifications of the sheetting material are as follows:

- (1) Fiber content: 100% cotton
- (2) Color: White
- (3) Construction: Plain weave, 19–33 threads per square centimeter (120–210 threads per square inch)
- (4) Weight/square yard:  $125 \pm 28$  g/m<sup>2</sup> ( $3.7 \pm 0.8$  oz/yd<sup>2</sup>).

(b) The sheetting shall be refurbished once before use with the following laundering procedure. The sheetting material shall be washed and dried one time in accordance with sections 8.2.2 and 8.2.3 of American Association of Textile Chemists and Colorists (AATCC) Test Method 124–2001 “Appearance of Fabrics after Repeated Home Laundering.” Washing shall be performed in accordance with sections 8.2.2 and 8.2.3 of AATCC Test Method 124–2001 using wash temperature (V)  $60 \pm 3$  °C ( $140 \pm 5$  °F) specified in Table II of that method, and the water level, agitator speed, washing time, spin speed and final spin cycle specified in “Normal/Cotton Sturdy” in Table III of the method. A maximum wash load shall be 8 pounds. Drying shall be performed in accordance with section 8.3.1(A) of that test method, Tumble Dry, using the exhaust temperature ( $66^\circ \pm 5$  °C;  $150^\circ \pm 10$  °F) and cool down time of 10 minutes specified in the “Durable Press” conditions of Table IV of the method.

**§ 1634.14 Standard polyurethane foam substrate.**

(a) The SPUF substrate is used for assembly of the mockups for evaluation of upholstery cover fabric and interior fire barriers and to qualify standard cover fabrics.

(b) *Flammability performance.* (1) Open flame performance. The SPUF shall be tested in accordance with the test procedures specified in § 1634.6, but without the use of the standard cover fabric and using a 5-second impingement of the 35 mm butane flame specified in § 1634.20(d). In three consecutive trials, using SPUF from the production lot to be qualified, the SPUF substrate shall have a mass loss that is greater than 20 percent in less than 120 seconds after removal of the ignition source.

(2) *Smoldering performance.* The SPUF shall be tested in accordance with the test procedures specified in § 1634.4, but without the use of a cover fabric. In three consecutive trials, using SPUF from the production lot to be qualified the SPUF substrate shall have a mass loss less than 1%.

(c) The SPUF substrate shall have the following specifications:

- (1) Density: 1.8 lb/ft<sup>3</sup>
- (2) Indentation Load Deflection (ILD): 25 to 30
- (3) Air permeability: Greater than 4.0 ft<sup>3</sup>/min
- (4) No flame-retardant chemical treatment as determined by post-production chemical analysis.

**§ 1634.15 Standard cover fabric (cotton velvet) smoldering qualification for barrier test.**

(a) *Flammability properties.* The standard cover fabric used in smoldering tests for interior fire barriers in accordance with § 1634.5, shall meet the following requirements: when tested directly over a qualified SPUF foam substrate following the procedure in § 1634.4, the substrate mass loss average of 10 test results shall be  $50 \pm 5\%$ .

(b) The standard cover fabric shall also have weight/square yard: 10 oz/yd<sup>2</sup>.

(c) A 100% cotton, velvet pile fabric of beige color, with no backcoating and treated with certain finishing chemicals involving a resin catalyst that contains small amounts of melamine, generally demonstrates the desired flammability performance characteristics specified.

**§ 1634.16 Conditioning.**

(a) All test specimens and standard test materials (including SPUF substrates, cigarettes, and sheetting material) shall be conditioned at a temperature of  $21^\circ \pm 3$  °C ( $70^\circ \pm 5$  °F) and between 50% and 66% relative humidity for at least 24 hours prior to testing.

(b) If conditions in the test room do not meet these specifications, then testing must be initiated within 10 minutes after the specimens are removed from the conditioning room.

**Subpart D—Test facility, exhaust system, and hazards**

**§ 1634.17 Test facility and exhaust system.**

The room in which tests under this part are conducted shall have a volume greater than 20 m<sup>3</sup> in order to contain sufficient oxygen for testing, or if smaller, the room shall have a ventilation system permitting the necessary flow of air. During the pretest and testing period, airflow rates shall be maintained below 0.1 m/s, measured in the locality of the mockup assembly to provide adequate air movement without disturbing the burning behavior. Room ventilation rates before and during tests shall be maintained at about 200 ft<sup>3</sup>/min. Airflow rates in this range have been shown to provide adequate oxygen without physically disturbing the burning behavior of the ignition source or the mockup assembly. In addition, the ventilation system of the test facility

shall be capable of extracting smoke and toxic combustion products generated during testing for health and safety reasons.

#### § 1634.18 Hazards.

(a) Health and safety risks associated with conducting the required testing in accordance with this part 1634 exist. It is essential that suitable precautions be taken, which include the use of breathing apparatus and protective clothing. Products of combustion can be irritating and dangerous to test personnel. Test personnel should avoid exposure to smoke and gases produced during testing.

(b) A suitable means of fire extinguishment shall be at hand. When the termination point of the test has been reached and the fire is extinguished, the presence of a back-up fire extinguisher is recommended. It is often difficult to determine when combustion in a mockup assembly has ceased, even after an extinguishment action is taken, due to burning deep inside the specimens. Care should be taken that specimens are disposed of only when completely inert.

#### Subpart E—Test Facility and Materials for Open Flame Ignition Resistance Tests

##### § 1634.19 Test room.

The test room shall be draft protected and equipped with a suitable ventilation system for exhausting smoke and any toxic gases generated during testing.

##### § 1634.20 Butane gas flame ignition source.

(a) The butane gas flame ignition source shall be in accordance with the following specifications or equivalent:

(1) The burner tube shall consist of a stainless steel tube,  $8.0 \pm 0.1$  mm ( $5/16 \pm 0.004$  inch) outside diameter,  $6.5 \pm 0.1$  mm ( $0.256 \pm 0.004$  inch) internal diameter.

(2) The butane shall be "C.P. Grade" (chemically pure) butane, 99.0% purity.

(b) There shall be a means to control the flow rate of butane.

(c) In the open flame test of section 1634.6 a nominal 240 mm flame butane is required. The nominal 240 mm butane flame is obtained by establishing a flow rate of butane gas that is  $350 \pm 10$  ml/min at 25 °C (77 °F) and 101.3 kPa (14.7 psi).

(d) In standard material qualification tests for SPUF and Rayon, a nominal 35 mm butane is required. The nominal 35 mm butane flame is obtained by establishing a flow rate of butane gas that is  $45 \pm 2$  ml/min at 25 °C (77 °F) and 101.3 kPa (14.7 psi).

(e) Flame height is measured from the center end of the burner tube when held horizontally and the flame is allowed to burn freely in air.

##### § 1634.21 Metal test frame.

(a) The metal test frame shall consist of two rectangular steel frames locked at right angles to each other [See Figure 6].

(b) The frames shall be made of nominal 25 mm x 25 mm (1 x 1 inch) steel angle 3 mm (0.125 inch) thick, and shall securely hold platforms of steel mesh set  $6 \pm 1$  mm ( $0.25 \pm 0.05$  inch) below the front face of each test frame.

(c) An optional standard edging section around the steel mesh will provide protection and greater rigidity. The rod shall be continuous across the back of the apparatus.

##### § 1634.22 Standard cover fabric (rayon) open flame qualification for barrier test.

(a) The standard cover fabric used in open flame tests for interior fire barriers shall be tested in accordance with the test procedures specified in § 1634.6 using a 20 second application of the 35 mm butane gas flame specified in § 1634.20. In five consecutive trials, the assembly mass loss must be greater than 40% at 5 minutes when tested with a qualified SPUF.

(b) The standard rayon cover fabric shall also:

(1) Be 100% bright regular rayon, scoured, 20/2 ring spun basket weave construction; and

(2) Have weight/square yard:  $8.0 \pm 0.5$  oz/yd<sup>2</sup>.

##### § 1634.23 Open flame tests fabric cut-out dimensions.

The fabric cut-out dimensions needed for installing in the mockup assembly to conduct open flame tests are shown in Figure 5.

##### § 1634.24 Standard polyurethane foam substrate.

(a) The SPUF substrate used for assembly of mockups shall meet the following flammability performance requirements.

(1) The SPUF shall be tested in accordance with the open flame test procedures specified in § 1634.6, but without the use of the standard cover fabric and using a 5-second impingement of the 35 mm butane flame specified in § 1634.20(d). In three consecutive trials, using SPUF from the production lot to be qualified, the SPUF substrate shall have a mass loss that is greater than 20 percent in less than 120 seconds after removal of the ignition source.

(2) The SPUF shall be tested in accordance with the smoldering test procedures specified in § 1634.4, but

without the use of a cover fabric. In three consecutive trials, using SPUF from the production lot to be qualified the SPUF substrate shall have a mass loss less than 1%.

(b) The SPUF substrate shall have the following specifications:

(1) Density: 1.8 lb/ft<sup>3</sup>

(2) Indentation Load Deflection (ILD): 25 to 30

(3) Air permeability: Greater than 4.0 ft<sup>3</sup>/min

(4) No flame-retardant chemical treatment as determined by post production chemical analysis.

##### § 1634.25 Conditioning.

(a) All test specimens and standard test materials shall be conditioned at a temperature of  $21^\circ \pm 3^\circ$  C ( $70^\circ \pm 5^\circ$  F) and between 50% and 66% relative humidity for at least 24 hours prior to testing.

(b) If conditions in the test room do not meet the conditioning specifications, then testing must be initiated within 10 minutes after the specimens are removed from the conditioning room.

#### Subpart F—Reupholstering

##### § 1634.26 Requirements applicable to reupholstering.

(a) Section 3 of the Flammable Fabrics Act (15 U.S.C. 1192) prohibits, among other things, the "manufacture for sale" of any product which fails to conform to an applicable standard issued under the FFA.

(b) Reupholstering upholstered furniture for sale is manufacturing upholstered furniture for sale and, therefore, is subject to the FFA and all applicable requirements of this part.

(c) Reupholstering is any replacing of upholstered furniture material that is subject to any applicable performance requirements of §§ 1634.4 through 1634.6.

(d) If the person who reupholsters the upholstered furniture intends to retain the reupholstered furniture for his or her own use, or if a customer hires the services of the reupholsterer and intends to take back the reupholstered furniture for his or her own use, "manufacture for sale" has not occurred and such an article of reupholstered furniture is not subject to this part.

(e) If an article of reupholstered furniture is sold or intended for sale, either by the reupholsterer or the owner of the upholstered furniture who hires the services of the reupholsterer, such a transaction is considered to be "manufacture for sale" and the article of upholstered furniture is subject to all applicable requirements of this part.

Dated: February 14, 2008.  
**Alberta E. Mills,**  
*Acting Secretary, Consumer Product Safety Commission.*

**Note:** The following appendix will not appear in the Code of Federal Regulations.

**List of Relevant Documents**

1. Briefing memorandum from Dale R. Ray, Project Manager, Directorate for Economic Analysis, to the Commission, "Regulatory Alternatives for Upholstered Furniture Flammability," November 20, 2007.
2. Memorandum from Rohit Khanna & S. Mehta, Directorate for Engineering Sciences, to Dale R. Ray, Project Manager, Directorate for Economic Analysis, "Technical Rationale Report for the Draft Standard for the Flammability of Upholstered Furniture," November 2007.
3. Memorandum from D. Miller, Directorate for Epidemiology to Dale R. Ray,

- Project Manager, Directorate for Economic Analysis, "Analysis of Laboratory Data for Upholstered Furniture," November 16, 2007.
4. Memorandum from Robert Franklin, P.C. to Dale R. Ray, Project Manager, Directorate for Economic Analysis, Environmental Assessment of a Draft Proposed Flammability Standard for Residential Upholstered Furniture," November 2007.
5. Memorandum from Charles L. Smith, Directorate for Economic Analysis, to Dale R. Ray, Project Manager, "Preliminary Regulatory Analysis of a Draft Proposed Flammability Rule to Address Ignitions of Upholstered Furniture," December 2007.
6. Memorandum from Charles L. Smith, Directorate for Economic Analysis, to Dale R. Ray, Project Manager, Directorate for Economic Analysis, "Proposed Rulemaking on Upholstered Furniture Flammability, Initial Regulatory Flexibility Analysis," December 2007.
7. Memorandum from Martha A. Kosh, Office of the Secretary, to Directorate for

- Economic Analysis, "Ignition of Upholstered Furniture by Small Open Flames and/or Smoldering Cigarettes," List of Comments on CF 04-2, December 29, 2003, revised October 19, 2004.
  8. Memorandum from A. Bernatz, L. Fansler & L. Scott, to Dale R. Ray, Project Manager, Directorate for Economic Analysis, "Test Program for Upholstery Fabrics and Fire Barriers," November 8, 2007.
  9. Memorandum from P. Semple, Executive Director, to the Commission, "Finding of No Significant Impact from Implementation of the Proposed Flammability Standard for Residential Upholstered Furniture," November 19, 2007.
  10. Memorandum from W. Zamula, Directorate for Economic Analysis, to Dale R. Ray, Project Manager, Directorate for Economic Analysis, "Costs for Non-Fatal, Addressable Residential Civilian Injuries Associated with Upholstered Furniture Fires," September 6, 2007.
- BILLING CODE 6355-01-P**

Figure 1 - Cigarette Ignition Specimen Holder - Base

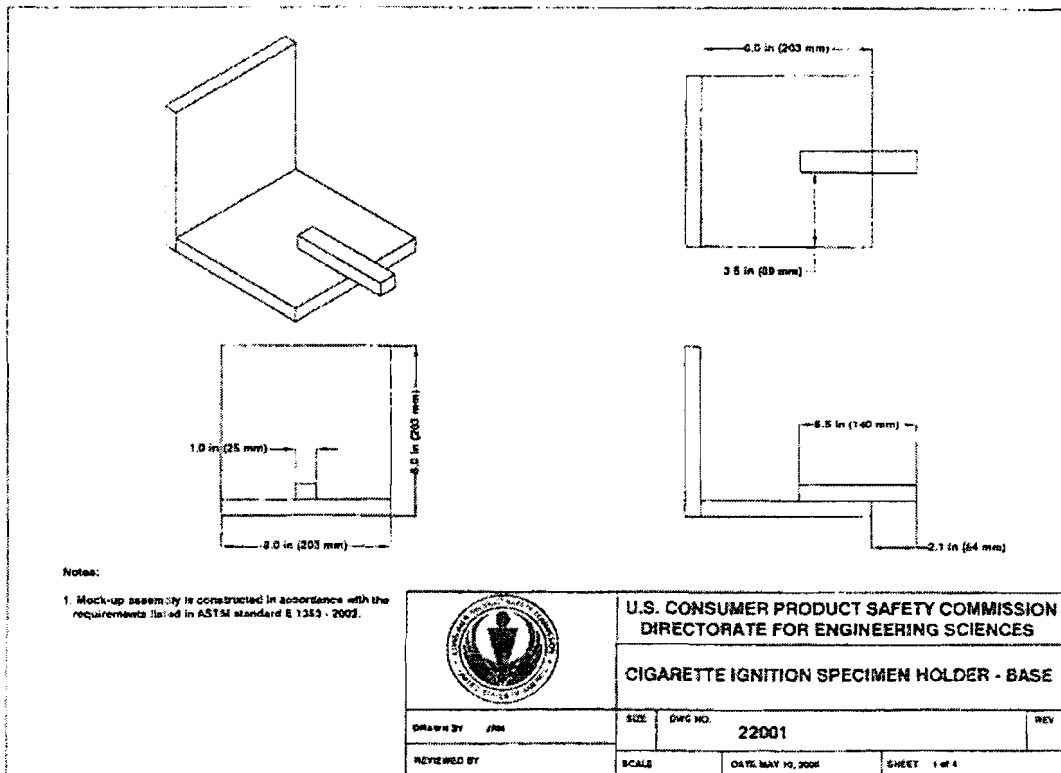

Figure 2 - Cigarette Ignition Specimen Holder - Movable Horizontal Support Panel

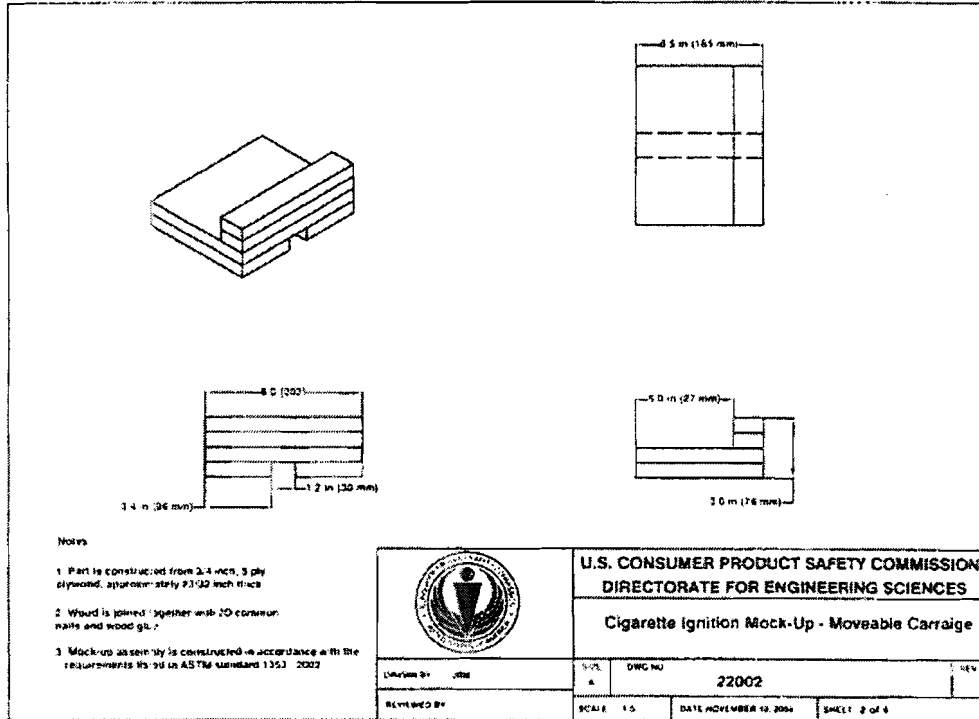

Figure 3 - Mockup Assembly for Upholstery Cover Fabric Smoldering Ignition Resistance Test

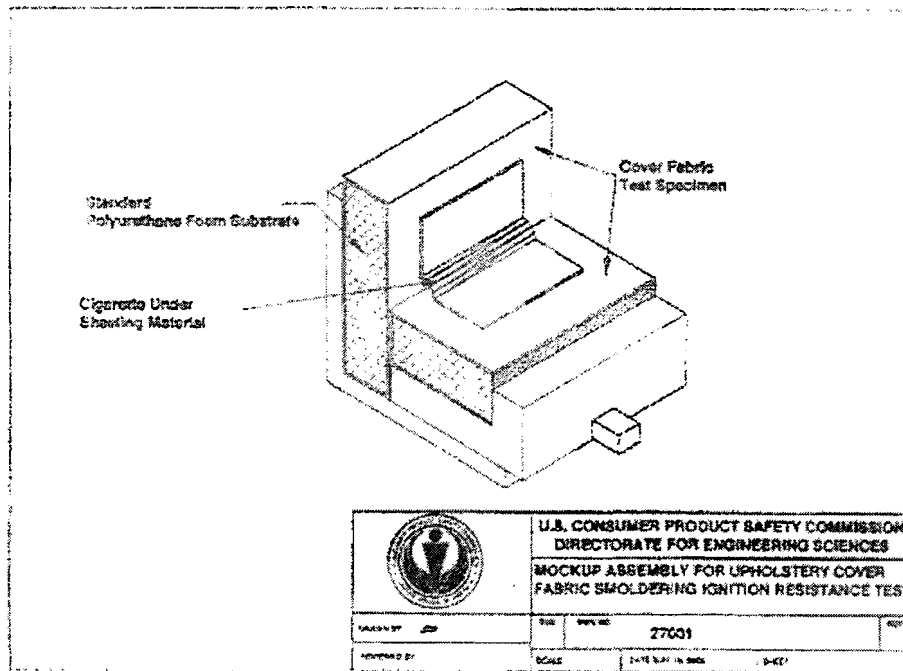

Figure 4 - Mockup Assembly for Interior Fire Barrier Material Smoldering Ignition Resistance Test

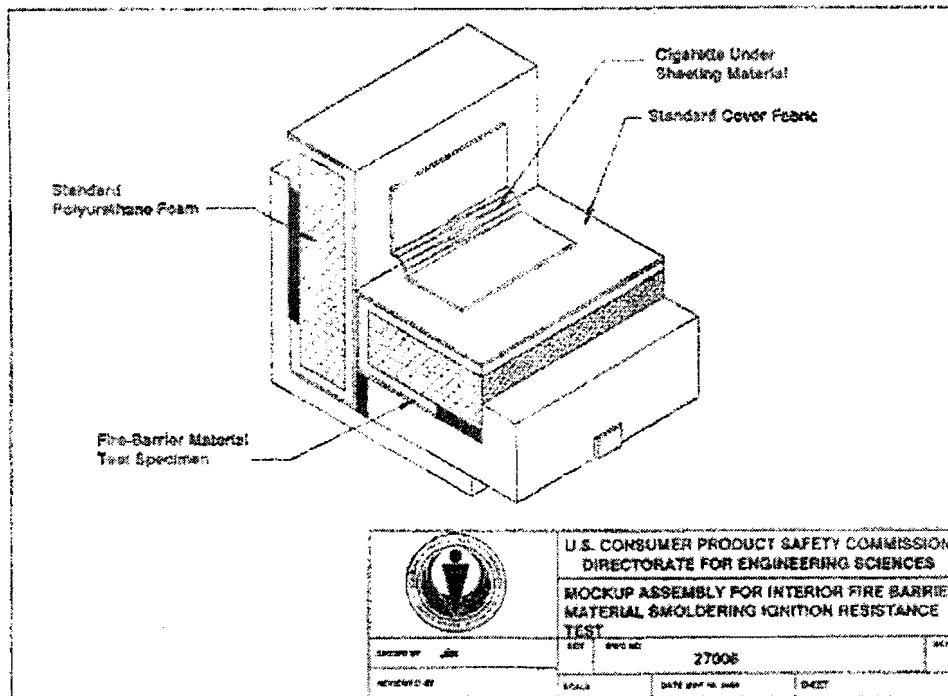

Figure 5 - Cut-Out Template Dimensions for Open Flame Test

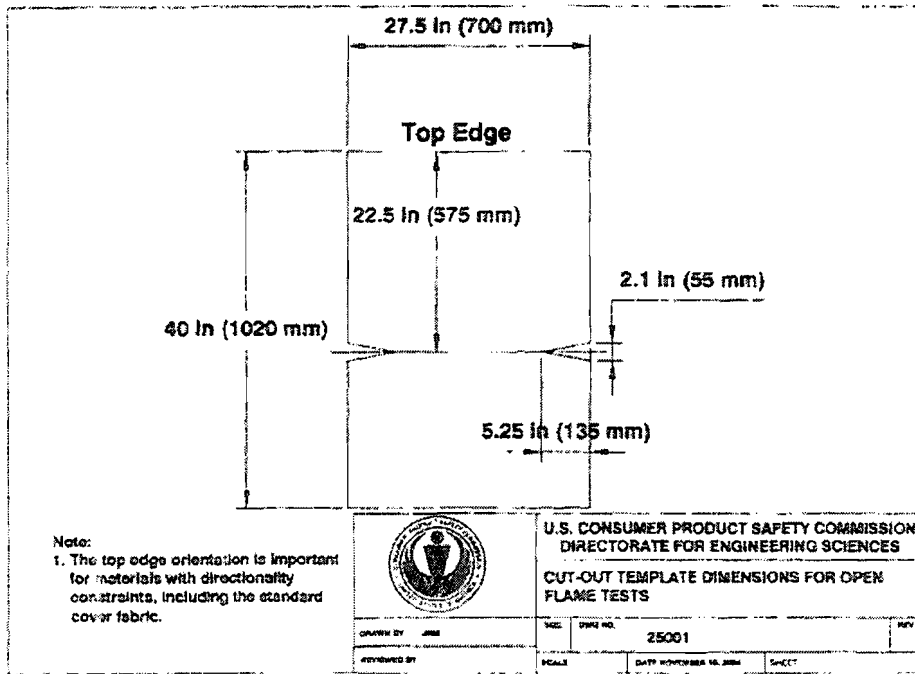
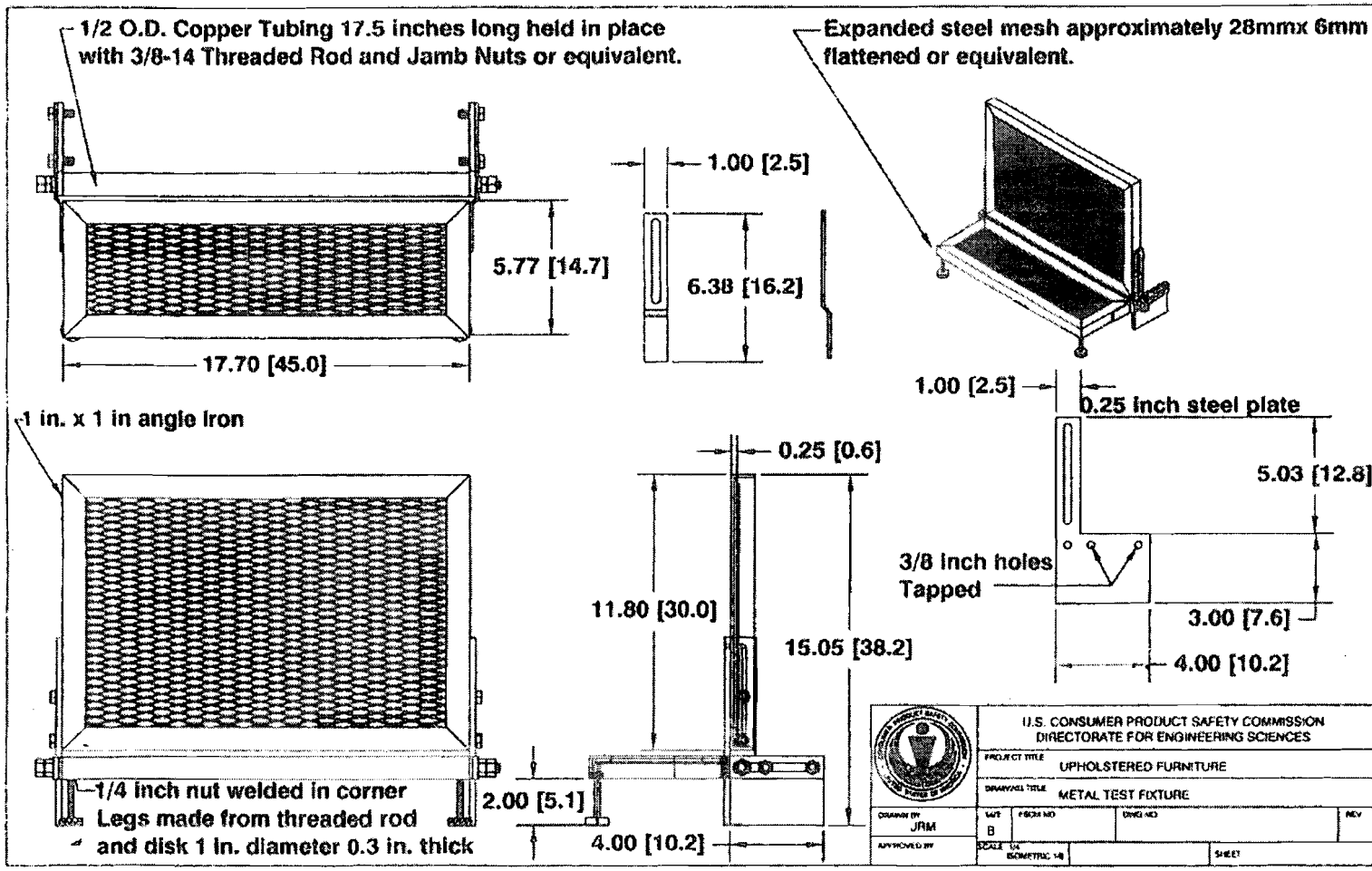

Figure 6 - Open Flame Metal Test Frame





**Stevenson, Todd**

---

**From:** Chris.Smith@coats.com  
**Sent:** Friday, May 02, 2008 1:54 PM  
**To:** CPSC-OS; Ray, Dale  
**Cc:** Shantanu.Banerjee@COATS.COM; Bill.Stuckey@coats.com  
**Subject:** Coats North America / CFR Part 1634 Comments

**Attachments:** 16 CFR Part 1634 Proposed Rule Uph Furn-Marked with Revision Suggestions by Coats NA.pdf



16 CFR Part 1634  
Proposed Rule...

Dale,  
It was a pleasure to speak to you today about the possibility of draft revisions. Please see the attached file with Coats comments.

(See attached file: 16 CFR Part 1634 Proposed Rule Uph Furn-Marked with Revision Suggestions by Coats NA.pdf)

Thanks,  
Chris

---

Chris Smith  
Director of Governmental Affairs, CNA  
Coats North America  
3430 Toringdon Way  
Suite 301  
Charlotte, NC 28277

Phone US: (704) 329-5002  
Cell US: (704) 756-0819  
Fax US: (704) 329-5970

e-mail: [chris.smith@coats.com](mailto:chris.smith@coats.com)

\*\*\*\*\*  
This communication may be confidential and privileged and the views expressed herein may be personal and are not necessarily the views of Coats plc. It is for the exclusive use of the intended recipient(s). If you are not the intended recipient(s), please note that any distribution, copying or use of this communication or the information in it is strictly prohibited. If you have received this communication in error, please notify us by email ([Apps.Support@coats.com](mailto:Apps.Support@coats.com)) or telephone our technical support helpdesk at Coats plc. +44 (0)20 8210 5100 (UK 0830H - 1800H, Mon-Fri, GMT) and then delete the email and any copies of it.  
\*\*\*\*\*

**Subject:** Upholstered Furniture NPR  
Reply to Federal Register Document of  
Tuesday March 4<sup>th</sup>, 2008 Part II  
Consumer Product Safety Commission  
16CFR Part 1634  
Standard for the Flammability of Residential Upholstered Furniture;  
Proposed Rule  
[cpsc-os@cpsc.gov](mailto:cpsc-os@cpsc.gov)  
Attention: Office of the Secretary,  
Consumer Product Safety Commission  
Room 502  
4330 East- West Highway  
Bethesda, Maryland 20814  
Telephone (301) 504-7530

To whom it may concern,

The following comments are in reference to the published document.

1. **Reference Vol. 73 ,no.43 11725 ~paragraph 6 “Therefore, Increased material cost probably would be \$2.01 to 2.48 per linear yard” ...** In Type II -where a 70second 240 mm open flame ignition is concerned, the robustness need for adequate flame barrier is more realistic in the \$3.25 to \$4.25+ range. Assumption is a 60” fabric for linear yard.
2. We are concerned that the constraints set in the Type II barrier test smoldering and open flame would only allow higher cost fiber barriers (Kevlar, Nomex, Basofil e.g.). In this event of the higher cost fiber flame barriers, the lower cost chemically treated products may be ruled out. In our experience, these more economical flame barriers are just as effective in performance for realistically protecting SPUF from igniting (e.g., treated cellulosic/ polyester blends commonly used to meet 16 CFR 1633).
3. It would appear that historical proposals of 1.5 inch butane flame (38mm) for 70 seconds would be adequate to create an ignition. The 240 mm flame ignition seems to be severe and does not appear to logically align with commonly occurring residential ignition sources. As proposed, this ignition source may rule out more cost efficient materials that would adequately resist or retard ignition of the foam as barrier materials for the forty five minute test duration.
4. **11743 Starting with item (6) “Remove Cotton sheeting ... to 1634.6 “Interior Fire Barrier”...**
  - a. The dissection of a burnt or completed test mockup with SPUF and the Standard Ticking over the barrier (except for academia) lends to excessive error in the final results by “novice” labs. We are referring to quality control at a typical textile or furniture manufacturing site. Expensive equipment and highly trained individuals would be necessary to accomplish the objectives of the test as written.
  - b. Relative to test complexity – inadvertent endorsement of the use of outside testing facilities vs. in house quality control make domestically manufactured materials thereof more cost prohibitive.

The US manufacturer of raw materials (textiles) and furniture experience severe competitive strain caused by unregulated foreign government subsidized imports.

c. We do not see this as proper governmental stewardship. This arduous test as written, and the cost of compliance, maintains an unwanted burden on the USA manufacturer. The jobs and revenue they create should be respected in the effort. Given lives are to be saved, much opportunity to improve the test and compliance without compromising the technical objective remain.

d. Therefore I recommend the following to simplify the test for the novice or manufacturing lab:

- **Weigh mass of all components separately before hand**: standard ticking, SPUF, barrier X, specimen holder.
- **Perform test as described** up to the point of dissection (45minute termination) either by placing test assembly and weighing on a nonflammable 15"x15" ceramic or concrete board (tare with the scale ) on top of scale accurate to 0.1 gram.  
**Another idea is pre-weigh sample assembly with components** on the scale, perform the ignition test off the scale, and weigh assembly at forty five minutes.
- **Develop an algorithm** to account for total assembly mass loss of the Standard Ticking, Barrier "X", cover sheet, and cigarette- that is ***\*realistic*** for a passing result and not requiring arduous assembly dissection.

E.g. ***Proposed or modified specification***:

"Equal to" or "less than" one percent mass loss specification of the SPUF is now "Equal to" or "less than" five percent to ten percent??... accounting for the Standard Ticking component weight loss, and weight loss of insulated Flame Barrier component "X".

With the above proposed test procedure no arduous dissection is necessary. The labor time required is therefore abbreviated, also creating a safer test design for the operator.

e. I would suggest that if the test had to be extinguished by a mass adding system, one could probably predetermine fit for use by looking at the dynamic weight loss. This would involve running the test as prescribed on a ceramic type fireproof board placed on an appropriate scale in the testing hood or area. (Ref. Calf. 117 2004 draft).

As soon as the weight exceeds the proposed ***\*realistic mass loss specification***, the test could be terminated and appropriately extinguished.

If it makes forty five minutes with recorded mass and is under ***\*realistic mass loss specification***, (E.g. still smoldering) no dissection is needed. At this point the assembly extinguishing can take place without test objective interference. This could also abbreviate test cycle time. If it makes open flame or mass loss via proposed failure mode, it is terminated anyway.

Thanks for your careful consideration of these comments. Please feel free to contact me for discussion.

Sincerely ,

Ladson L.(Larry) Fraser Jr. – Research & Development

Precision Fabrics Group Incorporated

301 East Meadowview Road

Greensboro, NC 27420-1448

Phone: 336 -510- 3139; mobile 336- 209 -0333

[larry.fraser@precisionfabrics.com](mailto:larry.fraser@precisionfabrics.com)

**Stevenson, Todd**

---

**From:** Fraser, Larry [Larry.Fraser@precisionfabrics.com]  
**Sent:** Friday, May 02, 2008 12:26 PM  
**To:** CPSC-OS  
**Cc:** Kale, Lisa; Small, Doug; Walton, John; Baldwin, Frank  
**Subject:** Upholstered Furniture NPR -Precision Fabrics Group Inc. 05-02-2008 -PFG reference DR6044  
**Importance:** High  
**Attachments:** Ladson L Fraser (Larry).vcf; PFG NPR 05-02-2008 CPSC 16 CFR Part1634-Upholstered Furniture NPR -March 4th 2008 CPSC federal registry.doc

Please see attached Upholstered Furniture NPR word document.

Per Tuesday March 4<sup>th</sup> 2008 document CPSC 16CFR part 1634

Please advise any difficulty with attached WORD document-(read only) .

Sincerely,

Ladson L. Fraser – Precision Fabrics  
Mobile 336 209 0333

---

The information and any files contained in this e-mail are intended only for the individual or entity to which it is addressed and may contain confidential, proprietary and/or privileged material. If you are not the intended recipient you should not review, disseminate, distribute or take any action in reliance upon the information. If you received this in error please contact the sender and delete the material from all computers.

## Stevenson, Todd

---

**Full Name:** Ladson L. Fraser (Larry)  
**Last Name:** Fraser  
**First Name:** Ladson  
**Job Title:** Research & Development - Nonwoven Products  
**Company:** Precision Fabrics Group Inc.

**Business Address:** Greensbor Finishing Plant  
301 East Meadowview Road  
Greensboro, NC 27420-1448

**Other Address:** Freight:  
Greensboro Finishing Plant  
200 Patton Ave.  
Greensboro, NC 27406

**Business:** (336) 510-3139  
**Home:** (336) 887-4888  
**Mobile:** (336) 209-0333  
**Business Fax:** (336) 510-3123

**E-mail:** Larry.Fraser@precisionfabrics.com  
**E-mail Display As:** Ladson L. Fraser (Larry) (Larry.Fraser@precisionfabrics.com)

**Web Page:** <http://www.precisionfabrics.com>

**Stevenson, Todd**

---

**From:** Ray, Dale  
**Sent:** Monday, May 05, 2008 1:55 PM  
**To:** Khanna, Rohit; Mehta, Shivani; Adair, Patricia; Fansler, Linda; Scott, Lisa; Smith, Charles L.; Miller, David; Babich, Michael; Rodgers, Gregory; Aiken, Deborah  
**Cc:** Tenney, Allyson; Stevenson, Todd  
**Subject:** Another NPR Comment

Well, here's one.

Todd, I assume he sent this to you separately (?)

*Dale R. Ray*  
*Directorate for Economic Analysis*  
*U.S. Consumer Product Safety Commission*  
*4330 East-West Hwy., Rm. 600*  
*Bethesda, MD USA 20814-4408*  
*tel: 301-504-7704*  
*fax: 301-504-0109*  
*dray@cpsc.gov*

---

**From:** Blair Schrader [mailto:blair@schraderbeds.com]  
**Sent:** Monday, May 05, 2008 12:01 PM  
**To:** Ray, Dale  
**Subject:** New Furn Regs

Good Morning Todd,

I would like to comment the CPSC Upholstered Furniture proposed regulations.

Getting to the point--I cannot believe that the CPSC would propose a regulation to destroy another segment in which small business makes up the majority of the industry.

Please look at what the 1633 regulation has done to the Mattress industry as a hole. We have been devastated on the supply side and the manufacturing side. I am hanging on because I don't want to blame the government for my closing. I have weathered 52 yrs of the economy and the regulations imposed on us by the State and the US government. But it makes me sad to see where the CPSC has put the bedding industry(and mainly the small manufacturer.)

Not only is the Manufacturer affected but the consumer now gets reduced choice and an inferior product.(IE--1 sided matts).

In the year since 1633 I know of 6 factories myself that have gone out of business and my main supplier has also closed her doors. All this because of the CPSC's non responsiveness to the small manufacturer.

I have had to diversify over the years. Upholstered furniture was a excellent addition to our niche in the industry. Now CPSC will invade that segment and destroy that side of our business thru the new regs.

5/5/2008

You want answers and suggestions? Leave the Upholstery industry alone or at least exempt the small manufacturer like OSHA has done. CPSC will destroy another viable part of the nations small business economy or make us go underground like has been done in the Mattress industry!

CPSC should concentrate on the regulations it now has on the books.

We should all be responsible for our own actions and quit being regulated to death. How can all this shift in responsibility be upheld while USA businesses are closing their doors?

MANY THANKS!  
Blair J. Schrader  
E.J. SCHRADER CO., INC.  
SINCE 1956



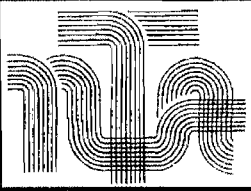

# National Textile Association

6 Beacon Street • Suite 1125 • Boston, Massachusetts 02108

617 542-8220 • [info@nationaltextile.org](mailto:info@nationaltextile.org) • [www.nationaltextile.org](http://www.nationaltextile.org) • 617 542-2199 fax

BY FAX AND MAIL

May 5, 2008

Desk Officer  
Consumer Product Safety Commission  
Office of Information and Regulatory Affairs  
Office of Management and Budget  
Washington, DC 20503

Re: Upholstered Furniture NPR

Dear Desk Officer for the Consumer Product Safety Commission (CPSC):

The National Textile Association (NTA) is pleased to comment on the Consumer Product Safety Commission's proposed mandatory Upholstered Furniture Flammability rule published in the March 4, 2008 *Federal Register*, pages 11701 – 11752. There are serious testing and recordkeeping issues which would have an enormous negative impact on our members, specifically the upholstery fabrics industry. We have also addressed several alternatives not included by the Commission which we believe are more cost effective and would not reduce the levels of safety for the public.

The NTA is the largest trade association representing the U.S. Textile Industry, and consists of approximately 100 companies that spin yarns; manufacture fabrics; dye, finish and print fabrics; and cut and sew top-of-the-bed textile products. Our comments are submitted primarily on behalf of our Upholstery Fabrics Committee, a committee comprised largely of small businesses that manufacture an enormous number of upholstery fabric styles and products, many in lengths as small as 50 linear yards or shorter. Most products produced by these decorative fabric weavers range in price from moderate to upper end, and they are sold to furniture manufacturers and distributors that service the upper end of the furniture market.

Lack of Test Data to Clearly Substantiate a Mandatory Standard. The Consumer Product Safety Commission proposed this regulation, which has as its centerpiece a test for upholstery fabric flammability that is entirely new to our industry. The proposal was made without the necessary testing to determine if the standard would, in fact, produce safer furniture. The Agency has produced very little small-scale test data and no full-scale testing to substantiate the technical assumptions that have been made in the proposed rule.

Over the past 30 years, no other CPSC rule that we know of has been proposed where technical data, including small-scale and full-scale tests, have been so skimpy and have not been available for review by the impacted industry. It appears this particular proceeding was "rushed" to a vote to meet the late February deadline when the Commission would lose its quorum again.

Impact on Small Business Greatly Underestimated. According to our industry experts, less than two dozen upholstery fabric manufacturers produce the large majority of upholstery fabrics in the U.S. and about a dozen of these would be adversely affected by the proposed flammability rule. These firms, comprised almost entirely of small businesses, manufacture the large majority of all upholstery fabrics that fall in the categories of "Severely Cigarette-Ignition-Prone Cellulosics" and "Moderately Cigarette-Ignition-Prone Cellulosics" as outlined in the March 4 *Federal Register* on page 11722.

The impact this mandatory furniture flammability standard would have on these small businesses is greatly underestimated in the proposed rule. In fact, for these few companies alone, the testing and recordkeeping burden is magnitudes greater than that suggested by the Agency.

Table I below lists the testing costs and recordkeeping costs for a sample of six small decorative weavers, members of NTA, who were able to provide data within the short comment period on the enormous number of styles of fabrics that would be required for testing under the Agency's proposed rule. Companies have combined similar products to reduce the overall number of required tests and have used the cost per test data referenced in the Initial Regulatory Flexibility Analysis.

These estimates are extremely conservative because there was not enough time to test fabrics and determine which would pass the fabric test for Type 1 Furniture and therefore be approved for use on Type 1 Furniture. Companies "assumed" that their Upholstered Furniture Action Council \* (UFAC) class I fabrics would pass the Commission's fabric test for Type 1 Furniture and, therefore, could be used to make furniture designated as the Commission's Type 1. However, Commission staff acknowledged that their testing has shown that some UFAC class I fabrics fail the new CPSC fabric test for Type 1 Furniture. Because of this fact, we likely projected that more of our members' fabrics could be used on CPSC Type 1 Furniture than is the actual case.

**Table I: Testing and Recordkeeping Costs**

Company	Testing Costs (\$)	Recordkeeping Costs (\$)	Total (\$)
A	2,400,000	166,000	2,566,000
B	1,758,000	137,000	1,895,000
C	4,197,000	378,000	4,575,000

D	5,750,000	520,000	6,270,000
E	5,600,000	234,000	5,834,000
F	5,375,000	481,000	5,856,000
<b>Total</b>	<b>25,080,000</b>	<b>1,916,000</b>	<b>26,996,000</b>

For these six companies, annual costs, after the initial year, would be approximately \$1,500,000 for the range of new patterns introduced annually. Recordkeeping costs for these six companies after the initial year would be approximately \$140,000.

It is important to note that the companies that participated in this survey have workforces that range in size from 50 to 250 employees. None of the companies, or any of that comprise the group most vulnerable to this standard, have testing labs that can even come close to conducting the volume of tests which would be required by the rule. Therefore, virtually all testing for compliance would be outsourced to commercial testing labs which would likely be severely overwhelmed if the standard is promulgated as proposed. This brings into question the \$50 per test value assigned by the Agency; as demand goes up, normally costs rise accordingly.

Skills of technicians who would perform the fabric flammability tests are very important. These technicians should be trained professionals who are capable of making technical judgments on issues such as whether any smolder exists at the conclusion of 45 minutes. This judgment is critical in reporting accurate data.

The overwhelming question, though, is whether the fabric test for Type 1 Furniture is a true predictor or indicator of how a fabric performs, and more importantly, how the furniture performs. The fact that the test has not undergone a precision and bias study or any other evaluation leaves open the issue of whether it is acceptable for regulatory purposes.

The Commission's tests are so new that very little small-scale and no full-scale testing has been generated to determine relevance of small scale to full scale. This work, at a minimum, should have been done before moving to the Notice of Proposed Rulemaking phase of developing a mandatory standard.

Alternate Proposals. Based on requirements under the Initial Regulatory Flexibility Analysis, we believe several important alternative approaches to the proposed mandatory standard were omitted and we would like to suggest several that we believe have merit. The options we are suggesting would likely reduce the cost of the regulation without reducing the level of safety contained in the proposed rule.

**Alternative 1. Fabric Test Using Fiberfill Barrier.** The large majority of furniture (estimated to be 95%) is currently manufactured using a polyester fiberfill material

between the cover fabric and foam. This synthetic product serves as a smolder barrier and can provide protection from ignition of interior components when using certain cover fabrics that do not pass the fabric test for Type 1 Furniture. We believe that by adding a Type 1A fabric test (same mock-up apparatus and pass/fail criteria as the fabric test for Type 1 Furniture but with non-slickened fiberfill barrier placed between the cover fabric and foam) as an option before requiring the expensive barrier material for Type 2 Furniture would provide greater flexibility for fabric and furniture manufacturers and would enable more fabrics to be used with minimal or no additional furniture construction costs. The level of safety should be unchanged from the Commission's proposal.

While we cannot quantify the cost savings this option would bring about for the fabric and furniture industries due to the shortage of time to evaluate this new proposal, we hope to have more specific information by the May 19 closing date for public comments. Nonetheless, we view this as a tremendous opportunity to reduce the overall cost of the standard and an option that would reduce the huge burden on our members and other companies faced with the same upholstery fabric cost issues associated with the proposed rule.

**Alternative 2. Reduced Ignition Propensity (RIP) Cigarettes.** In the NPR, CPSC refers to RIP cigarettes by saying "Particularly noteworthy is the expected growth in the availability of cigarettes that reduce the probability of igniting upholstered furniture." The agency continues by saying that RIP cigarettes are expected to greatly reduce, but not eliminate, residential fires started by cigarettes. However, it stops short of suggesting a role for RIP cigarettes either in the proposed mandatory standard or any of its alternatives.

The second largest cigarette manufacturer, R.J. Reynolds Tobacco Company, has declared that it will convert its entire line of cigarettes to the self-extinguishing type by the end of 2009, and other large cigarette manufacturers are moving in the same direction, it seems that RIP cigarettes should play a vital role in any standard for the future.

If a mandatory standard is necessary, we believe a major alternative to the Commission's proposal should be to test fabrics using RIP cigarettes instead of the standard non-filtered, non-RIP Pall Mall which is no longer being produced. The RIP cigarette should be the standard ignition source for all alternative methods suggested in this letter.

In our opinion, the Agency's proposal should be re-evaluated simply on the fact that the standard cigarette required for testing by the mandatory proposal has not been produced since February 2008 and this has created a shortage of cigarettes for testing purposes – if you are not able to find a source that has a supply of standard cigarettes in inventory, those who wish to test are at a severe disadvantage for evaluating upholstery fabrics. This is especially critical since the Agency changed to a completely new fabric test for which no small-scale data were available except for a small number

of samples tested and maintained by CPSC's laboratory. The new test became available to the public at the time the proposed standard was announced.

**Alternative 3. Exemption from the Rule.** While it is a well known fact that heavyweight cellulosic fabrics do not perform as well as lighter fabrics or fabrics made of other fibers in small-scale and large-scale smoldering tests, there are no data available to suggest that these heavyweight cellulosic fabrics are involved in actual furniture fires where a smoldering ignition source is present. The main reason for this lack of data is that heavyweight cellulosic fabrics are used on high-end furniture that is sold to customers in upper economic levels who normally have much lower smoking rates and live in occupancies with working smoke detectors and, many times, sprinkler systems.

The long history of data on furniture fires fails to isolate heavyweight cellulose as a major or even minor real life furniture fire problem when smoldering ignition was the cause. In fact, discussions with several prominent expert witnesses who have been active in furniture flammability cases and have testified in numerous fire investigations, emphatically state that heavyweight cellulosic upholstery fabrics are generally never involved in furniture flammability cases.

To the contrary, most furniture flammability cases have occurred in lower socioeconomic communities where less expensive furniture has either been purchased or passed down through families or has been purchased at other second hand sources. Many times, these cases involve older furniture that is worn in some areas and normally is covered with fabrics other than heavyweight cellulose. With this being the case, an option for the Commission to consider is to exempt furniture covered with heavyweight cellulosic fabrics from the mandatory standard because, from a practical point, this is not the furniture type which is involved in flammability incidents.

In closing, we appreciate the opportunity to file comments on the true costs of testing and recordkeeping which would be borne by many small upholstery fabric businesses if CPSC's proposed upholstered furniture standard is promulgated. We also appreciate the chance to suggest several additional alternatives that we believe would much less costly to American consumers but would not reduce the level of safety described in the Commissions' proposal.

Sincerely,

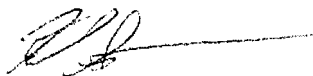

Karl Spilhaus  
President

KS/jl

**Stevenson, Todd**

---

**From:** Hardy Poole [hpoole@nationaltextile.org]  
**Sent:** Monday, May 05, 2008 3:31 PM  
**To:** CPSC-OS  
**Subject:** Comment to the Consumer Product Safety Commission  
**Attachments:** OBM letter0001.pdf

Please see National Textile Association comment on the Consumer Product Safety Commission's proposal mandatory Upholstered Furniture Flammanability rule published in the March 4, 2008 Federal Register, pages 11701-11752.

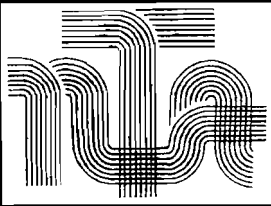

# National Textile Association

6 Beacon Street • Suite 1125 • Boston, Massachusetts 02108

617 542-8220 • [info@nationaltextile.org](mailto:info@nationaltextile.org) • [www.nationaltextile.org](http://www.nationaltextile.org) • 617 542-2199 fax

16A

May 19, 2008

Office of the Secretary  
Consumer Product Safety Commission  
4330 East West Highway  
Bethesda, MD 20814  
[cpsc-os@cpsc.gov](mailto:cpsc-os@cpsc.gov)

OFFICE OF THE SECRETARY  
FREEDOM OF INFORMATION  
2008 MAY 23 P 1:52

Re: Upholstered Furniture NPR

Dear Madam Acting Secretary:

The National Textile Association (NTA) is pleased to file comments regarding the Consumer Product Safety Commission's (Commission) proposed Standard for the Flammability of Residential Upholstered Furniture. We have been strong proponents of improving the flammability characteristics of upholstered furniture and are long-time supporters of the only formal program directed to this purpose, the Upholstered Furniture Action Council's (UFAC) voluntary program, and are proud of the accomplishments this program has achieved.

We also realize that the continuous reduction in deaths from smoldering furniture fires has also been due to a variety of other factors such as the role of smoke detectors and the fact that fewer American now smoke.

The NTA is the largest trade association representing the U.S. Textile Industry, and consists of approximately 100 companies that spin yarns; manufacture fabrics; dye, finish and print fabrics; and cut and sew top-of-the-bed textile products. Our comments are submitted primarily on behalf of our Upholstery Fabrics Committee, a committee comprised almost entirely of small businesses that manufacture an enormous number of upholstery fabric styles and products, many being in runs as small as 50 linear yards. Most products produced by our decorative fabric weavers range in price from moderate to upper end, and they are sold to furniture manufacturers and distributors that service the upper end of the furniture market.

## Introduction

Our industry has been involved in Upholstered Furniture flammability issues with CPSC for more than 30 years. We have seen a vast number of approaches to address the flammability problem, and we have discussed numerous technical approaches with Commission staff and other industry sectors. However, we have never seen the Commission move so quickly to the Notice of Proposed Rulemaking (NPR) stage with so few hard facts and concrete data. The NPR appears to have been hurriedly assembled with very little small-scale data and no full-scale data to support the proposal, truly a step taken without the normal back-up study and supporting information expected for a proceeding that has been underway for over three decades. The technical aspects of the proposal seem to be based on unproven assumptions.

In fact, Commissioner Moore, in his February 1, 2008 statement said, "...the design and implementation of the validation testing for this proposed standard will be critical in determining how effective the draft standard will be in reducing fire deaths and injuries." He also said he intends to pay close attention to the preliminary regulatory analysis which relies heavily on a number of unproven assumptions.<sup>1</sup>

Commissioner Moore also believes that, "Until validation testing is done on large-scale mockups or full-scale furniture samples, we do not know how effective the standard will really be or how well the bench-scale mockup is at predicting effectiveness."<sup>2</sup> This powerful statement suggests that the rule was not developed fully enough to be advanced to the NPR stage and an enormous amount of testing by industry and the Commission remains to be done.

We believe the proposal is incomplete in that it did not address several key issues that are critically important to reduce furniture flammability incidents. The upholstery fabrics sector in the United States has changed drastically over the past five years and the proposal does not appear to acknowledge these changes as it includes out-of-date and inaccurate information in its analysis and overlooks several other promising options for addressing the problem.

By proposing a completely new fabric smoldering test method in the NPR and then allowing only limited time for industry to collect fabrics and conduct tests the proposal does not allow for a thorough evaluation of the method by those who will be most greatly affected, thus eliminating the opportunity for industry to evaluate the full impact this method will have on the upholstery fabrics industry. We strongly encourage the Commission to allow adequate time for the upholstery fabrics industry to evaluate this new test method, and we encourage the Agency to immediately share with us its test data based on the new method.

---

<sup>1</sup> Statement of The Honorable Thomas H. Moore on the Vote to Approve the *Federal Register* Notice for the Upholstered Furniture Rulemaking

<sup>2</sup> Statement of The Honorable Thomas H. Moore on the Regulatory Alternatives to Address the Flammability of Upholstered Furniture



There are no short cuts in evaluating this new test. CPSC staff has said that many UFAC class 1 fabrics will pass the new CPSC test method, but staff is quick to follow up by saying that all UFAC class 1 fabrics will not pass, thus leaving it up to the industry to evaluate the almost unlimited number of styles of fabrics produced to determine which will meet the new CPSC test and which will not. (See attached May 5, 2008 NTA letter to OMB for indication on testing and recordkeeping costs associated with the Commission proposal). Adequate time for the Commission and industry to complete testing to fully evaluate the proposal and its impact on the industry and consumers is imperative before the issue is considered as a final rule.

#### What is the Problem?

The problem being addressed is primarily smoldering ignition of upholstered furniture. It is a well-known fact that heavyweight cellulosic (cotton, rayon, etc.) fabrics do not perform as well in smoldering tests as thermoplastic fiber fabrics or lighter weight cellulosic fabrics. But the Commission should not ignore that the key portion of the issue is identifying actual fabrics that are involved in furniture fires. At this point we have not seen any data on this issue, and we believe that the agency should develop a profile on the fabric types involved in furniture fires before the proceeding advances.

Speaking of heavyweight cellulosic fabrics that tend to be smolder prone, the staff notes in the NPR that, "To the extent that furniture with smolder prone fabrics is more often found in higher-income households with lower smoking prevalence, the benefits of a flammability rule could be reduced somewhat."

We have contacted several expert witnesses who have participated in hundreds of furniture flammability suits throughout the nation over the years. According to them, heavyweight cellulosic fabrics have not been highlighted in furniture fires and therefore we believe these types of fabrics are being falsely accused as the culprits in the problem. Surely they might not perform as well as thermoplastic or lighter weight cellulosic fabrics in laboratory smoldering tests, but are they actually involved in the relatively few remaining furniture fires resulting from smoldering ignition that occur each year? We believe that they are not and therefore they should not be singled out as the culprits when they are rarely involved in fires. We would like to see the Agency's data showing the degree of involvement of heavyweight cellulosic fabrics in actual furniture fires started by smoldering sources.

#### Performance Basis of Fabric for the Proposed Type I Furniture Standard

At this point, we have not seen test data, either small-scale or large-scale, that is adequate to show that the proposal will be effective in reducing smoldering fires in upholstered furniture. Therefore, we believe, at this point, that the proposal is arbitrary and capricious, and severely penalizes only one sector of the supply chain, the small business dominated decorative fabric weavers.

### Fabric Industry in Transition

The upholstery fabrics industry has been undergoing a massive transition especially over the past five years with the changes accelerating greatly in the last two years. Of the five upholstery fabric companies mentioned in the NPR, none is an active fabric producer in the U.S. today. Though the number of domestic upholstery fabric manufacturers noted by CPSC staff was 100 to 200, today's count is closer to two dozen and the large majority are small business. These small businesses employ between 50 and 250 employees and provide an almost unlimited number of styles of fabrics for the furniture industry.

An indication of the enormous testing and recordkeeping costs which would be thrust on these small businesses is contained in the May 5, 2008 NTA letter to the Office of Management and Budget. You'll see in our calculations on the number of tests required per company, based on our sample of manufacturers, that the total number of tests is magnitudes higher than the number projected by the Commission.

The NPR describes the tremendous changes in the upholstery fabrics industry in recent years. It reported that one manufacturer, previously a major U.S. producer of upholstery fabrics that was liquidated in 2007, estimated that 60 percent of furniture upholstery fabric sales were imported by the end of 2006. This trend has continued.

### Reduced Ignition Propensity (RIP) Cigarettes

The NPR's opening sentence addressing RIP cigarettes makes a powerful statement: "Particularly noteworthy is the expected growth in the availability of cigarettes that reduce the probability of igniting upholstered furniture." This relatively new product can have a greater impact on reducing the number of furniture fires started by smoldering sources at a lower cost than any single solution that has been proposed. According to the Coalition for Fire Safe Cigarettes, 76% of the U.S. population is now or soon will be better protected by RIP cigarettes.

The percentage of our population affected by RIP cigarettes continues to grow. We recognize that RIP cigarettes will not necessarily provide 100% protection against smoldering furniture fires but it should address a very large proportion of these fires, and the impact should be realized much quicker than any mandatory standard. Because of the extremely important role of RIP cigarettes in improving overall fire safety, we would like to be kept apprised of the Agency's progress in evaluating the impact of RIP cigarettes on upholstery fabrics, and we will be pleased to provide assistance with fabric samples, etc. if needed.

Because of the rapid increase in the number of jurisdictions requiring RIP cigarettes, we believe if a mandatory standard is promulgated, it should, as a minimum, rely on RIP cigarettes for small-scale and large-scale testing. This recommendation is particularly timely since the production of the Commission's standard cigarette for testing upholstery fabric and furniture (non-filter king size

Pall Malls) ceased last February and its manufacturer, R.J. Reynolds Tobacco Company, has stated it does not plan to make this product any longer.

Leading cigarette makers are moving quickly to RIP-type products. As stated in the NPR, R.J. Reynolds Tobacco Company, which makes about one third of the cigarettes sold in the U.S., has announced that it intends to market only RIP cigarettes by the end of 2009, and other cigarette manufacturers have indicated similar trends. The impact of RIP cigarettes should be evaluated carefully as the least costly, quickest and most efficient way to reduce deaths, injuries and property damage from fires resulting from smoldering ignition sources.

The Coalition for Fire Safe Cigarettes has several very impressive facts about RIP cigarettes on its homepage. Prominently displayed is the fact that:

*NFPA research in the mid-1980s predicted that fire-safe cigarettes would eliminate three out of four cigarette fire deaths. If cigarette manufacturers had begun producing only fire-safe cigarettes then, an estimated 17,000 lives could have been saved by now.*

Applying this projection to the latest data on deaths attributable to smolder ignition of upholstered furniture, the reduction would be more than 200 lives saved. Truly, no standard could achieve this improvement level in fire safety as fast as RIP cigarettes.

#### Fabric Test for Type 1 Furniture

The fabric test for Type 1 Furniture is similar to other tests which the Commission has reviewed but contains enough different aspects that it is impossible to predict how a fabric will perform in the new test based on past performance. This means that fabric testing conducted by industry and government alike over the past 30 years cannot be used to determine the impact of the new fabric test for Type 1 Furniture and therefore, only new fabric tests which meet the requirements of the new proposal will have value.

It would also be helpful to have the Commission staff's test data based on this new method which would help us select the most meaningful fabric types for our review. Though we plan to test products using CPSC's fabric test for Type 1 Furniture, it is extremely important to acknowledge that the test method has not undergone an evaluation to determine its precision and bias.

We have tried to develop small-scale test data to include in this statement but time has not allowed us to do so. However, we will be conducting an expanded program on fabrics in the future and would like to gain more knowledge of small-scale testing by having access to the Commission's test data. Our intention is to continue our testing program and, we hope, evaluate the true impact of the proposed fabric test for Type 1 Furniture and also evaluate several options to this method.

### Options for Fabrics that Do Not Pass the Fabric Test for Type I Furniture

According to the Commission's proposal, fabric manufacturers have three options when a fabric does not pass the Type I Furniture test: 1) the fabric can be re-engineered; 2) the fabric can be treated with flame retardant (FR) chemicals; and 3) the fabric can be sold for use in Type 2 Furniture using an appropriate barrier. All three options lead to incurred costs and options one and two incur additional changes in fabric aesthetics such as drape, hand and perhaps functionality.

The textile industry has done an enormous amount of fabric re-engineering to achieve class 1 UFAC fabrics. Changes in constructions, fiber blends and other parameters have optimized the smoldering performance of these fabrics and additional changes will lead to large shifts in the overall types of fabrics offered by our industry – changes that our customers do not desire.

While it appears that the FR requirement for polyurethane foam was dropped due to concerns about human health and chemical safety, this change places more emphasis on the upholstery fabrics industry to use FR chemicals to provide fabrics for Type 1 Furniture. Though the Commission staff says it is unlikely that fabric suppliers would use FR treatments, the industry considers the use of FR chemicals as a feasible option to meeting the proposed rule for some fabrics.

The upholstery fabrics industry does its best to select chemical systems which are believed to be safe and will always follow this strictly; however, it is important to point out that chemical treatments on fabrics, by their very nature, provide an opportunity for exposure to chemicals via absorption (skin contact), inhalation (breathing) and ingestion (oral contact). Treated polyurethane foam appears to provide exposure only via inhalation and that exposure is minimized due to the cover fabric acting as somewhat of a barrier.

### Add A New Version of the Fabric Test for Type 1 Furniture

Alternative 1 in our letter to the Office of Management and Budget describes a variation of the fabric test for Type 1 Furniture which we propose be added as an option to satisfying the Type 1 Furniture fabric. (For discussion, refer to the added test as the fabric test for Type 1A Furniture.) The test is identical to the proposed fabric test for Type 1 Furniture, including the same pass/fail criteria, except unslickened polyester fiberfill is placed between the cover fabric and foam. This slight change provides additional improvement over typical slickened battings used in today's furniture construction, and fabrics that meet the pass/fail criteria of the fabric test for Type 1A Furniture should be allowed for use in appropriate furniture constructions.

In the NPR, CPSC staff says that many smolder-prone fabrics can sometimes overwhelm the inherent smolder resistance of synthetic filling materials such as polyester batting, and we agree. However, it is a known fact that polyester batting such as unslickened polyester fiberfill can provide insulation properties that will prevent smoldering ignition of furniture for some, but clearly not all,

fabrics that are categorized as smolder prone. The addition of this fabric test for Type 1A Furniture would allow more fabrics to be used safely at a much lower cost to the consumer than the required application of a barrier for Type 2 Furniture.

In conducting these tests (Type 1 and Type 1A), we propose that RIP cigarettes be used. With state laws rapidly changing to require RIP cigarettes and with the requirement already in place to impact cigarettes sold in states that contain more than three quarters of the U.S. population, it is reasonable to substitute RIP cigarettes into the test protocols to reflect real life exposure. A standard that does not specify RIP cigarettes will be out dated before it is promulgated.

#### Imported Upholstery Fabrics and Furniture

With the rapid increase of upholstery fabrics and furniture imported in the United States and with limited resources by the Commission, U.S. Customs Service and other federal enforcement agencies, we strongly encourage coordination among those organizations with authority to determine if these imported products meet the required level of compliance in the United States, and that swift and appropriate action be taken for those who are not in compliance.

#### Test Data and Analysis

Due to the complexities of collecting fabrics and conducting the new CPSC fabric test for Type 1 Furniture, no test data is available for submission with our comments. However, we will be conducting a variety of test to determine the impact of the Commission's new fabric test for Type 1 Furniture on the many products made by our members.

As noted in the March 4, 2008 **Federal Register** NPR notice, parties may request the opportunity to present comments orally before the Commission. We intend to request this opportunity and would like to present more information about the impact this proposed regulation will have on our industry, once we have had the opportunity to evaluate it fully.

We appreciate the opportunity to file our comments on this important rulemaking. Please let me know if I can answer any questions.

Sincerely,



Karl Spilhaus  
President

KS/jl

Attachment: May 5, 2008 NTA Letter to OMB

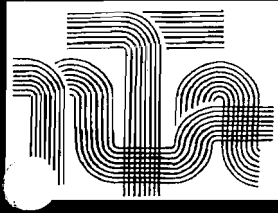

# National Textile Association

6 Beacon Street • Suite 1125 • Boston, Massachusetts 02108

617 542-8220 • [info@nationaltextile.org](mailto:info@nationaltextile.org) • [www.nationaltextile.org](http://www.nationaltextile.org) • 617 542-2199 fax

BY FAX AND MAIL

May 5, 2008

Desk Officer  
Consumer Product Safety Commission  
Office of Information and Regulatory Affairs  
Office of Management and Budget  
Washington, DC 20503

Re: Upholstered Furniture NPR

Dear Desk Officer for the Consumer Product Safety Commission (CPSC):

The National Textile Association (NTA) is pleased to comment on the Consumer Product Safety Commission's proposed mandatory Upholstered Furniture Flammability rule published in the March 4, 2008 *Federal Register*, pages 11701 – 11752. There are serious testing and recordkeeping issues which would have an enormous negative impact on our members, specifically the upholstery fabrics industry. We have also addressed several alternatives not included by the Commission which we believe are more cost effective and would not reduce the levels of safety for the public.

The NTA is the largest trade association representing the U.S. Textile Industry, and consists of approximately 100 companies that spin yarns; manufacture fabrics; dye, finish and print fabrics; and cut and sew top-of-the-bed textile products. Our comments are submitted primarily on behalf of our Upholstery Fabrics Committee, a committee comprised largely of small businesses that manufacture an enormous number of upholstery fabric styles and products, many in lengths as small as 50 linear yards or shorter. Most products produced by these decorative fabric weavers range in price from moderate to upper end, and they are sold to furniture manufacturers and distributors that service the upper end of the furniture market.

Lack of Test Data to Clearly Substantiate a Mandatory Standard. The Consumer Product Safety Commission proposed this regulation, which has as its centerpiece a test for upholstery fabric flammability that is entirely new to our industry. The proposal was made without the necessary testing to determine if the standard would, in fact, produce safer furniture. The Agency has produced very little small-scale test data and no full-scale testing to substantiate the technical assumptions that have been made in the proposed rule.

Over the past 30 years, no other CPSC rule that we know of has been proposed where technical data, including small-scale and full-scale tests, have been so skimpy and have not been available for review by the impacted industry. It appears this particular proceeding was "rushed" to a vote to meet the late February deadline when the Commission would lose its quorum again.

Impact on Small Business Greatly Underestimated. According to our industry experts, less than two dozen upholstery fabric manufacturers produce the large majority upholstery fabrics in the U.S. and about a dozen of these would be adversely affected by the proposed flammability rule. These firms, comprised almost entirely of small businesses, manufacture the large majority of all upholstery fabrics that fall in the categories of "Severely Cigarette-Ignition-Prone Cellulosics" and Moderately Cigarette-Ignition-Prone Cellulosics" as outlined in the March 4 *Federal Register* on page 11722.

The impact this mandatory furniture flammability standard would have on these small businesses is greatly underestimated in the proposed rule. In fact, for these few companies alone, the testing and recordkeeping burden is magnitudes greater than that suggested by the Agency.

Table I below lists the testing costs and recordkeeping costs for a sample of six small decorative weavers, members of NTA, who were able to provide data within the short comment period on the enormous number of styles of fabrics that would be required for testing under the Agency's proposed rule. Companies have combined similar products to reduce the overall number of required tests and have used the cost per test data referenced in the Initial Regulatory Flexibility Analysis.

These estimates are extremely conservative because there was not enough time to test fabrics and determine which would pass the fabric test for Type 1 Furniture and therefore be approved for use on Type 1 Furniture. Companies "assumed" that their Upholstered Furniture Action Council \* (UFAC) class I fabrics would pass the Commission's fabric test for Type 1 Furniture and, therefore, could be used to make furniture designated as the Commission's Type 1. However, Commission staff acknowledged that their testing has shown that some UFAC class I fabrics fail the new CPSC fabric test for Type 1 Furniture. Because of this fact, we likely projected that more of our members' fabrics could be used on CPSC Type 1 Furniture than is the actual case.

**Table I: Testing and Recordkeeping Costs**

Company	Testing Costs (\$)	Recordkeeping Costs (\$)	Total (\$)
A	2,400,000	166,000	2,566,000
B	1,758,000	137,000	1,895,000
C	4,197,000	378,000	4,575,000

D	5,750,000	520,000	6,270,000
E	5,600,000	234,000	5,834,000
F	5,375,000	481,000	5,856,000
Total	25,080,000	1,916,000	26,996,000

For these six companies, annual costs, after the initial year, would be approximately \$1,500,000 for the range of new patterns introduced annually. Recordkeeping costs for these six companies after the initial year would be approximately \$140,000.

It is important to note that the companies that participated in this survey have workforces that range in size from 50 to 250 employees. None of the companies, or any of that comprise the group most vulnerable to this standard, have testing labs that can even come close to conducting the volume of tests which would be required by the rule. Therefore, virtually all testing for compliance would be outsourced to commercial testing labs which would likely be severely overwhelmed if the standard is promulgated as proposed. This brings into question the \$50 per test value assigned by the Agency; as demand goes up, normally costs rise accordingly.

Skills of technicians who would perform the fabric flammability tests are very important. These technicians should be trained professionals who are capable of making technical judgments on issues such as whether any smolder exists at the conclusion of 45 minutes. This judgment is critical in reporting accurate data.

The overwhelming question, though, is whether the fabric test for Type 1 Furniture is a true predictor or indicator of how a fabric performs, and more importantly, how the furniture performs. The fact that the test has not undergone a precision and bias study or any other evaluation leaves open the issue of whether it is acceptable for regulatory purposes.

The Commission's tests are so new that very little small-scale and no full-scale testing has been generated to determine relevance of small scale to full scale. This work, at a minimum, should have been done before moving to the Notice of Proposed Rulemaking phase of developing a mandatory standard.

Alternate Proposals. Based on requirements under the Initial Regulatory Flexibility Analysis, we believe several important alternative approaches to the proposed mandatory standard were omitted and we would like to suggest several that we believe have merit. The options we are suggesting would likely reduce the cost of the regulation without reducing the level of safety contained in the proposed rule.

**Alternative 1. Fabric Test Using Fiberfill Barrier.** The large majority of furniture (estimated to be 95%) is currently manufactured using a polyester fiberfill material



between the cover fabric and foam. This synthetic product serves as a smolder barrier and can provide protection from ignition of interior components when using certain cover fabrics that do not pass the fabric test for Type 1 Furniture. We believe that by adding a Type 1A fabric test (same mock-up apparatus and pass/fail criteria as the fabric test for Type 1 Furniture but with non-slickened fiberfill barrier placed between the cover fabric and foam) as an option before requiring the expensive barrier material for Type 2 Furniture would provide greater flexibility for fabric and furniture manufacturers and would enable more fabrics to be used with minimal or no additional furniture construction costs. The level of safety should be unchanged from the Commission's proposal.

While we cannot quantify the cost savings this option would bring about for the fabric and furniture industries due to the shortage of time to evaluate this new proposal, we hope to have more specific information by the May 19 closing date for public comments. Nonetheless, we view this as a tremendous opportunity to reduce the overall cost of the standard and an option that would reduce the huge burden on our members and other companies faced with the same upholstery fabric cost issues associated with the proposed rule.

**Alternative 2. Reduced Ignition Propensity (RIP) Cigarettes.** In the NPR, CPSC refers to RIP cigarettes by saying "Particularly noteworthy is the expected growth in the availability of cigarettes that reduce the probability of igniting upholstered furniture." The agency continues by saying that RIP cigarettes are expected to greatly reduce, but not eliminate, residential fires started by cigarettes. However, it stops short of suggesting a role for RIP cigarettes either in the proposed mandatory standard or any of its alternatives.

The second largest cigarette manufacturer, R.J. Reynolds Tobacco Company, has declared that it will convert its entire line of cigarettes to the self-extinguishing type by the end of 2009, and other large cigarette manufacturers are moving in the same direction, it seems that RIP cigarettes should play a vital role in any standard for the future.

If a mandatory standard is necessary, we believe a major alternative to the Commission's proposal should be to test fabrics using RIP cigarettes instead of the standard non-filtered, non-RIP Pall Mall which is no longer being produced. The RIP cigarette should be the standard ignition source for all alternative methods suggested in this letter.

In our opinion, the Agency's proposal should be re-evaluated simply on the fact that the standard cigarette required for testing by the mandatory proposal has not been produced since February 2008 and this has created a shortage of cigarettes for testing purposes – if you are not able to find a source that has a supply of standard cigarettes in inventory, those who wish to test are at a severe disadvantage for evaluating upholstery fabrics. This is especially critical since the Agency changed to a completely new fabric test for which no small-scale data were available except for a small number

of samples tested and maintained by CPSC's laboratory. The new test became available to the public at the time the proposed standard was announced.

**Alternative 3. Exemption from the Rule.** While it is a well known fact that heavyweight cellulosic fabrics do not perform as well as lighter fabrics or fabrics made of other fibers in small-scale and large-scale smoldering tests, there are no data available to suggest that these heavyweight cellulosic fabrics are involved in actual furniture fires where a smoldering ignition source is present. The main reason for this lack of data is that heavyweight cellulosic fabrics are used on high-end furniture that is sold to customers in upper economic levels who normally have much lower smoking rates and live in occupancies with working smoke detectors and, many times, sprinkler systems.

The long history of data on furniture fires fails to isolate heavyweight cellulose as a major or even minor real life furniture fire problem when smoldering ignition was the cause. In fact, discussions with several prominent expert witnesses who have been active in furniture flammability cases and have testified in numerous fire investigations, emphatically state that heavyweight cellulosic upholstery fabrics are generally never involved in furniture flammability cases.

To the contrary, most furniture flammability cases have occurred in lower socioeconomic communities where less expensive furniture has either been purchased or passed down through families or has been purchased at other second hand sources. Many times, these cases involve older furniture that is worn in some areas and normally is covered with fabrics other than heavyweight cellulose. With this being the case, an option for the Commission to consider is to exempt furniture covered with heavyweight cellulosic fabrics from the mandatory standard because, from a practical point, this is not the furniture type which is involved in flammability incidents.

In closing, we appreciate the opportunity to file comments on the true costs of testing and recordkeeping which would be borne by many small upholstery fabric businesses if CPSC's proposed upholstered furniture standard is promulgated. We also appreciate the chance to suggest several additional alternatives that we believe would much less costly to American consumers but would not reduce the level of safety described in the Commission's proposal.

Sincerely,

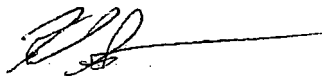

Karl Spilhaus  
President

KS/jl



May 5, 2008

Office of the Secretary  
Consumer Product Safety Commission  
4330 East-West Highway  
Bethesda, MD 20814

Re: Upholstered Furniture NPR

Dear Secretary Stevenson:

On behalf of the National Home Furnishings Association (NHFA), I wish to submit comments regarding the Notice of Proposed Rulemaking for a Standard for Flammability of Upholstered Residential Furniture.

The National Home Furnishings Association is the nation's largest organization devoted specifically to the needs and interests of home furnishings retailers. NHFA's membership comprises 2800 business entities representing 10,000 stores in all 50 states and several foreign countries.

We would like to submit comments on one issue unique to the retail sale of upholstered furniture. It may take three years or more for a retailer to liquidate the inventory of upholstered goods. Unlike other consumer goods, discontinued upholstered goods, particularly those which are single items of what may have originally been a part of a set of furnishings, are held in inventory for a considerable period of time. The retailer has a significant investment in those items and therefore complete early liquidation is not an option. It is a well-established industry standard that with patience and appropriate marketing, the retailer can recover a portion of the investment in that inventory.

For this reason, we strongly urge the Commission to adopt a rule, as it has in other rulemakings, that allows for the unrestricted sale of upholstered goods manufactured prior to the effective date of the rule.

Thank you for consideration.

Sincerely,

A handwritten signature in black ink, appearing to read "Steve DeLiaan", is written over a horizontal line.

Steve DeLiaan  
Executive Vice President

**Stevenson, Todd**

---

**From:** Mary Jane Bolek [mbolek@nhfa.org]  
**Sent:** Wednesday, May 07, 2008 2:47 PM  
**To:** CPSC-OS  
**Cc:** Steve DeHaan  
**Subject:** NPR - Standard for Flammability of Upholstered Residential Furniture  
**Attachments:** image001.emz; oledata.mso

Dear Secretary Stevenson:

Below are comments from Steve DeHaan, Exec. Vice President, National Home Furnishings Assn., with regard to the subject NPR:



California Building Industry Association

1215 K Street  
Suite 1200  
Sacramento, CA 95814  
916/443-7933  
fax 916/443-1960  
www.cbia.org

**2008 OFFICERS**

*Chairman*  
**RAYMOND C. BECKER**  
DMB  
El Rancho San Benito  
Hollister

*Vice Chairman*  
**HORACE HOGAN II**  
Brehm Communities  
Carlsbad

*CFO/Secretary*  
**JOHN R. YOUNG**  
Young Homes  
Rancho Cucamonga

*President & CEO*  
**ROBERT RIVINIUS, CAE**  
Sacramento

**MEMBER ASSOCIATIONS**

Building Industry Association of Central California Modesto

Building Industry Association of the Delta Stockton

Building Industry Association of Fresno/Madera Counties Fresno

Building Industry Association of San Diego County San Diego

Building Industry Association of Southern California Diamond Bar

Home Builders Association of Central Coast San Luis Obispo

Home Builders Association of Kern County Bakersfield

Home Builders Association of Northern California San Ramon

Home Builders Association of Tulare & Kings Counties Visalia

North State Building Industry Association Sacramento

*Upholster from NPA 12*

May 5, 2008

Nancy A. Nord  
Acting Chair  
Consumer Product Safety Commission  
4330 East West Highway  
Bethesda, MD 20814

Dear Madam Chair:

California homebuilders, represented by the California Building Industry Association (CBIA), wish to register their concerns regarding new chemical standards recently proposed by the Consumer Product Safety Commission (CPSC) that are in direct conflict with California's robust fire-safety regime.

The standard, proposed by the CPSC in November, 2007 for residential upholstered furniture – which is much less stringent than California's existing furniture flammability standards – would seriously impact the California homebuilding industry by effectively rendering obsolete the state's standards for fire-safe furniture in homes. Indeed, the proposed regulation preempts the California standard and sets a precedent for less protective standards for a broader range of commercial and consumer products in the state.

Additionally troubling is that the new standard is being advanced as a new consumer "safety" change – purporting that the flame retardant chemicals long used in these furniture products are harmful to humans, animals and the environment and discourages manufacturers and other producers to discontinue use of these safety products. This admonition against the use of fire retardants appears to run afoul of the CPSC's own research on flame retardants which within the last decade determined that the chemicals used were effective and safe for use in residential product applications. What's left is the absence of guidance to manufacturers, suppliers, retailers and ultimately consumers as to what is safe and what isn't and at great expense to the national economy.

CBIA recommends that the CPSC withdraw the current proposed new standard and, as has been done in the past, work toward developing a more reasonable, balanced and safe standard utilizing fire-safety experts and other relevant stakeholders in the process.

Thank you for your consideration.

Very sincerely yours,

Timothy L. Coyle  
Senior Vice President

*Upward from NPR*



May 5, 2008

Office of the Secretary  
Consumer Product Safety Commission  
4330 East West Highway  
Bethesda, MD 20814

Dear Chairman Nord:

The California Chamber of Commerce, CalChamber, would like to express our concern regarding the direction the CPSC is taking to weaken fire safety standards in California.

The Commission issued a proposed standard in November, 2007, for residential upholstered furniture that is substantially less stringent than California's existing furniture flammability standards. It would not apply to the most flammable components of upholstered furniture and does not include an open flame test, used for decades under California's performance-based standard to simulate actual sources of ignition common in residential settings. This standard, if adopted as is, would preempt the California standard and set a precedent for less protective standards for a broader range of commercial and consumer products.

We are also concerned that the Commission's proposal is predicated on the false premise that all flame retardant chemicals are harmful to humans, animals and the environment. In fact, the CPSC proposal specifically states that the standard should not rely on use of chemical flame retardants, and in so doing sends a message to manufacturers that they should discontinue use of products that have proven effective in significantly reducing incidence of residential fires, related deaths and injuries. This statement also disregards the CPSC's own research on flame retardant chemicals, leading to a determination in 1998 that half of the 16 substances tested were effective and safe for use in residential product applications.

Corporations have a social responsibility to distribute products that meet the highest standards of consumer safety. The CPSC should not adopt standards that erect regulatory barriers to achieving this objective. The current proposal would create a gap in public fire protection, and thus represents a very real threat to public health and safety that vastly eclipses any theoretical risk associated with incidental exposure to flame retardant chemicals.

In 2004, fire-fighters, physicians, environmentalists and manufacturers reached consensus on a proposal that would provide maximum fire protection for the public and preserve flexibility for manufacturers in order to ensure consistently safe, high quality products. We recommend the Commission issue a new proposal that incorporates this consensus approach, and which will not preempt proven measures already in place, such as in California.

Sincerely,  
  
Jason Schmelzer  
Policy Advocate

JS:ad

cc: cpssc-os@cpssc.gov

1215 K Street, Suite 1400  
Sacramento, CA 95814  
916 444 6670  
www.calchamber.com

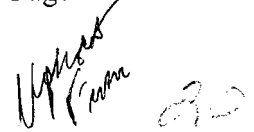

**Stevenson, Todd**

---

**From:** Simmons Bill - High Point Plant [Bill.Simmons@Kohler.Com]  
**Sent:** Tuesday, May 06, 2008 9:11 AM  
**To:** CPSC-OS  
**Subject:** Federal Register 73 FR 11702 (March 4, 2008)

I am writing to express my concern regarding the proposed standard for the flammability of upholstered furniture, 73 FR 11702. The proposal addresses the testing for ignition of fabrics from a smoldering cigarette. The test is based on using a Pall Mall cigarette in testing that will no longer be made. Before a standard is issued, testing should be done using the new Pall Mall fire safe cigarette which may alter test results achieved to date on a variety of fabrics. The root cause of upholstered furniture fires is the ignition source and a reduction in the heat source through reduced ignition propensity cigarettes is a significant step in decreasing the potential of a fire.

I do not understand why a fabric must be tested 10 times for compliance. Most test are conducted on a single pass/fail basis and continued testing of a fabric will only increase costs dramatically. If a single test results in a failure, flame retardant treatments could be applied to the fabric and retested for compliance saving the consumer additional costs and the manufacturer a lot of testing time and expense. The application of fire barriers adds considerable expense to the product and can affect the comfort of the furniture.

I would request that further testing be completed with the new ignition source and results analyzed to determine if the proposed standard is applicable. Thank you for your time and consideration of my concerns.

Regards,  
Bill Simmons  
Baker Furniture Company

Upholstered Furniture  
3/21

**GORDON H. DAMANT  
DAMANT AND ASSOCIATES**

3550 Watt Ave., Suite 5  
Sacramento, California 95821  
Phone 916-485-7018  
Fax 916-481-0252  
[gdamant@lycos.com](mailto:gdamant@lycos.com) and [gdamant2@yahoo.com](mailto:gdamant2@yahoo.com)

May 6, 2008

Office of the Secretary,  
Consumer Product Safety Commission  
4330 East West Highway  
Bethesda, MD 20814

**Comments Related to 16 CFR Part 1634 – Standard for the Flammability of Residential Upholstered; Proposed Rule**

The following comments are provided in response to the 16 CFR 1634 proposed rule for the Flammability of Upholstered Furniture, published in the Federal Register on March 4, 2008, pp. 11702 – 11752. After having worked on flammability problems related to upholstered furniture, mattresses, and a variety of other consumer products for the past 40 years both as a regulator and as a consultant, I appreciate the opportunity to comment on this important fire safety issue.

**General Comments**

To say that I am disappointed in the proposed flammability rule for upholstered furniture would be a gross understatement. I am frankly appalled that after about 35 years of effort seeking a solution to the serious and pervasive problem of furniture flammability that the current (incomplete) proposal is apparently the best solution that the Commission has been able to develop.

On November 29, 1972, more than 35 years ago, the U.S. Department of Commerce published a Notice in the Federal Register indicating that a flammability standard for upholstered furniture may be needed<sup>1</sup>. When the

<sup>1</sup> Federal Register, Vol 37, No. 230, November 29, 1972, Department of Commerce, Office of the Secretary (15 CFR Part 7), Upholstered Furniture, "Notice of Finding That Flammability Standard or Other Regulation May Be Needed and Institution of Proceedings".



Consumer Product Safety Commission (CPSC) commenced operation in 1973, and assumed responsibility for the promulgation and enforcement of standards pursuant to the Flammable Fabrics Act (FFA), the Commission inherited the previously published Federal Register notice. Almost from the first day of its existence in 1973, more than 35 years ago, the CPSC has focused on issues related to the flammability of furniture. It is sobering to note that a review of U.S. fire statistics since 1973 reveals that about 30,000 victims, many of them young children, have lost their lives from fires that are reported to have been started by the ignition of upholstered furniture. In addition to the many tragic deaths that have been caused by upholstered furniture fires since 1973, tens of thousands of additional victims have sustained debilitating burn injuries from furniture fires. Many of these burn survivors have sustained disfiguring injuries that will remain with them for the remainder of their lives. Many of these deaths and injuries have resulted from upholstered furniture fires caused by direct open-flame ignition. I suggest that the victims, and their families, would gain little satisfaction from the proposal that CPSC has produced after years of vacillation on this critically important issue of fire safety and consumer protection, that fails to address direct open-flame ignition of furniture.

The CPSC's failure to address this critical product safety issue expeditiously is frankly appalling, and is a great stain upon the reputation of a federal agency whose primary responsibility is product safety. With regard to improving the flammability of upholstered furniture it is my opinion, and that of many others, that the CPSC has failed miserably to provide the type of consumer protection and safety leadership that U.S. citizens expect from a federal agency.

One of the purposes of the Consumer Product Safety Act is stated as follows – “To protect the public against unreasonable risks of injury associated with consumer products”. Virtually every year since the CPSC started publishing annual “U.S. Fire Loss Estimates”, deaths resulting from upholstered furniture fires have been the number-one cause of U.S. fire deaths for any U.S. consumer product under CPSC's jurisdiction. The cumulative U.S. loss of life and burn injuries that have been caused by the ignition of upholstered furniture is a tragedy of major proportions. But an even greater tragedy is that it has taken the CPSC, a Federal agency with the specific responsibility for consumer product safety, more than 35 years to even formally propose a flammability standard to address this critical U.S. fire safety problem.

Almost every day I receive copies of press releases from the CPSC that memorialize that the agency has recalled X number of products (sometimes involving 10's of thousands of individual products) for known or suspected safety violations. Many of these releases contain language that suggests that, although the CPSC knows of no actual injuries or deaths resulting from the alleged safety defect(s), the recall action is taken to prevent injury or death that might occur due to the continued use of the potentially dangerous product. In such instances it appears that CPSC errs on the side of caution and takes preventative action to forestall potential injury. The contrast and disconnect between such recall regulatory actions (even though they are apparently initiated under a different section of the Act), and the CPSC's 35-year response to the catastrophic public safety problems caused by highly flammable residential upholstered furniture is beyond belief. Yes, the problem has been and continues to be challenging, but while CPSC has vacillated from one potential solution to another, other more progressive government agencies both in the United States and Europe have successfully implemented fire safety standards that address both cigarette and small open-flame ignition of furniture used in both residential and public occupancies.

Perhaps there may be criticisms of existing standards, and perhaps they are less than perfect. But the bottom line is that others have attempted to address this critically important fire safety problem, have developed standards, and have provided a level of protection and fire safety to their citizens that has been sadly lacking throughout much of the United States, primarily due to CPSC's ineptitude in addressing this critical fire safety issue. In the meantime, although apparently expending a great deal of time, money and employee resources, CPSC has substantially abdicated its responsibility, by failing to expeditiously and comprehensively address this important fire safety problem. Over a 35-year period CPSC has achieved very little relating to the fire safety of upholstered furniture, and has provided no safety to the public from furniture fires, despite the multitude of tragic deaths and injuries resulting from such fires. In my opinion the current CPSC proposal does little to improve the problems caused by residential furniture fires.

Upholstered furniture and bedding products constitute the major fuel loads in most homes. Both products, unless modified to be ignition resistant, are easily ignited by small flaming and smoldering ignition sources. The Commission's activities in recent years to address the open-flame ignition of mattresses and bed sets was a significant step forward in the fire safety of U.S. homes. In the mattress rulemaking the CPSC recognized the potential fuel load

of bedding systems. The agency further acknowledged that a significant step forward in U.S. residential fire safety could be achieved, not only by preventing ignition of bed sets, but also by significantly delaying the onset of flashover from bedding fires that may rapidly put an entire residence at risk.

Many in the fire safety community were greatly encouraged by the CPSC's approach to the fire safety of bed sets and anticipated, since bedding products and upholstered furniture are closely related, a similar approach would be used in the rulemaking relating to upholstered furniture. However, the science-based approach to fire safety employed in addressing the fire problem of mattresses and bed sets is sadly lacking in the current CPSC proposal related to upholstered furniture. The fact is that upholstered furniture may constitute a greater fuel load, and may be responsible for more rapid fire growth, than bedding products. But the CPSC has inexplicably chosen to largely ignore the fire growth and flashover dangers presented by upholstered furniture in the current proposal. It should also be pointed out that mattress producers have been required to comply with a mandatory CPSC standard for cigarette ignition resistance since 1974,<sup>2</sup> unlike the furniture industry that, outside of California, have faced no mandatory flammability requirements of any type for residential furniture. One can only conjecture that the difference between a cooperative and progressive industry, and one perhaps less cooperative and less progressive, played a significant role in the Commission's approach to this critical fire safety issue.

### History and Recent Developments

As previously noted the CPSC has been involved in upholstered furniture flammability activities since the early 1970's. In the early 1970's the CPSC worked with the National Bureau of Standards (NBS) in the development of a proposed test method for the cigarette ignition of furniture. A proposed cigarette ignition test method, PFF 6-76<sup>3</sup>, was developed by the Center for Fire Research at NBS and was provided to the CPSC in the mid-1970's. The record shows that 30 years ago the CPSC was presented with a cigarette test method for upholstered furniture, developed by one of the most prestigious fire research organizations in the world. For some reason that is not clearly apparent, even though in November 1978 CPSC staff recommended

---

<sup>2</sup> 16 CFR 1632 – “Standard for the Flammability of Mattresses and Mattress Pads (FF 4-72 amended)”.

<sup>3</sup> Back-Up Report for the Proposed Standard for the Flammability (Cigarette Ignition Resistance) of Upholstered Furniture PFF 6-76, NBSIR 78-1438, Joseph Loftus, Center for Fire Research, National Engineering Laboratory, National Bureau of Standards, Final Report June 1978.

that the NBS test method, with some modification, be published as a proposed standard. The Commission chose to reject the modified NBS proposal in favor of monitoring a furniture industry voluntary program developed under the auspices of an industry furniture consortium, the Upholstered Furniture Action Council (UFAC). It should be noted that the test method developed 30 years ago at NBS (PFF 6-76) has been adopted, with modifications, as consensus test methods by both the American Society for Testing and Materials (ASTM), and by the National Fire Protection Association (NFPA).<sup>4,5</sup>

It is ironic that today, CPSC has apparently rejected the UFAC program, which it had previously been so willing to embrace, and is now proposing a test method that addresses the same flammability issue for which a technical solution was proposed by the NBS 30 years earlier – ignition of furniture by smoldering cigarettes. One can only speculate on the lives that might have been saved, the injuries prevented, and the property loss that may not have occurred, had the CPSC not equivocated on this important safety issue 30 years ago. Unfortunately it is apparent to many that for the past 30 years, in the area of upholstered furniture flammability, the CPSC has failed dismally, and has been less than diligent, in its stated mission of providing any real consumer safety or protection on this important fire safety issue.

The current activity related to furniture flammability can be traced to a petition filed by the National Association of State Fire Marshals (NASFM) in 1993<sup>6</sup>. The NASFM petition requested a mandatory standard to address the flammability of upholstered furniture, and suggested several existing test methods the CPSC should consider. It is perfectly clear from the petition that a major thrust of NASFM's request was that CPSC not only focus on cigarette ignition of furniture, but also specifically address issues related to open-flame ignition of furniture products. State Fire Marshals were particularly concerned with reports of rapid fire development in modern homes when typical items of upholstered furniture were the first items to ignite. Investigators and fire researchers report that flashover from fires involving modern furniture may occur in as little as 3 minutes – long before the typical fire department is able to

---

<sup>4</sup> ASTM E 1352 – “Standard Test Method for Cigarette Ignition Resistance of Mock-Up Upholstered Furniture Assemblies”.

<sup>5</sup> NFPA 260 – “Standard Methods of Tests and Classification System for Cigarette Ignition Resistance of Components of Upholstered Furniture”.

<sup>6</sup> Petition for Promulgation of Upholstered Furniture Fabric Flammability Regulations Under the Flammable Fabrics Act, 15 U.S.C. §§ 1191 et seq., Submitted by the National Association of State Fire Marshals, March 31, 1993.

arrive at the fire scene, giving residents little time for detection of the fire, or escape from it.

Additionally it has been clear to fire authorities for many years that the major fuel load in furniture fires is the highly combustible filling-material hidden beneath upholstery fabrics. In recent years fire authorities have pushed strongly for either the protection of the highly flammable furniture filling materials, using some of the fire blocking techniques currently employed in current mattress production, or replacement of the filling materials by appropriate fire retardant materials. It has also been clear to both fire authorities and fire researchers for years that standards which primarily address the smoldering resistance of furniture cover fabrics and filling materials that are intimately adjacent will not suffice to prevent the rapid involvement of furniture fillings should even small open-flame ignition occur.

After due deliberation the Commission voted to partially grant NASFM's petition in 1994, published an Advance Notice of Public Rulemaking (ANPR)<sup>7</sup>, and specifically instructed CPSC staff to evaluate, and give consideration to all available furniture flammability test methods in the development of an appropriate CPSC furniture test standard. In October 1997 CPSC staff forwarded a briefing package to the Commission in which the staff concluding that a small open flame standard was feasible and a CPSC standard could effectively reduce the risks to consumers, including risks from both small open flame and cigarette ignitions. Subsequently, in 2003, the Commission voted to issue a second ANPR that included both cigarette and small open-flame ignition in the CPSC rulemaking on furniture flammability.

For many who had followed the CPSC furniture flammability activities over the years it was clear that the Commission had made the correct decision, though perhaps very belatedly, in choosing to address both cigarette and small open-flame ignition. It was the right thing to do, and we were encouraged that the Commission had finally seen the light and had chosen to follow a correct and scientifically valid approach to the furniture fire safety problem. To say the least I, along with many others, was astounded in late 2007 when informed that the CPSC had backed away from its previous position and was now concentrating only on cigarette ignition of furniture.

---

<sup>7</sup> ANPR 59 FR 30735. June 15, 1994. The portion of NASFM's petition requesting a small open-flame standard was granted; the portion requesting a large open-flame standard was denied; and the portion requesting a cigarette ignition standard was deferred pending further information about the effectiveness of the voluntary industry program on cigarette ignition of furniture.

The circumstances behind this apparent radical change of direction by the CPSC are somewhat vague, but in 2007 acting chairman Commissioner Nancy Nord apparently acting unilaterally instructed CPSC staff<sup>8</sup>, to change direction once again and to develop a flammability standard for furniture based only upon resistance to cigarette ignition. It is interesting to note that this important fire safety decision was made in relative secrecy, even without the knowledge of Commissioner Thomas Moore<sup>9</sup>. It is also apparent that, to my knowledge, this critical decision was made without the benefit of any open and public input or comment, particularly from interested parties, consumer groups or organizations such as the National Association of State Fire Marshals, who were the petitioners for an upholstered furniture standard in 1993, and who had specifically requested that CPSC address the serious fire problem of open-flame ignition. For an agency that has prided itself over the years on the openness of its regulatory process, the circumstances of the apparent process by which this critical decision was made leaves much to be desired and raises many questions relating to the openness of CPSC's decision making. The drastic change of direction by the CPSC clearly appears to repudiate the essence of the valid NASFM petition that had been granted by the Commission in 1994 and reiterated by additional Commission votes in 2003.

### Upholstered Furniture Flammability

A review of U.S. fire statistics, as well as investigations of fires caused by furniture, shows that upholstered furniture fires are primarily caused by three types of ignition source – cigarettes, small open-flames, and a variety of electrical devices. Cigarette-caused furniture fires always start as smoldering fires. The smoldering process may continue for as little as 30 minutes, but furniture may smolder for many hours, before the transition to flaming combustion. In some cases furniture smolders itself out, without ever flaming.<sup>10</sup> Small open-flame ignition of furniture, is usually caused by matches, lighters, and candles, and is frequently associated with child-play. The serious problem of child play has been well documented in several reports published by the National Fire Protection Association (NFPA).<sup>11, 12</sup> Ignition of furniture by

---

<sup>8</sup> Acting Chairman Nancy Nord, Opening Statement – Upholstered Furniture Briefing, December 6, 2007.

<sup>9</sup> Statement of the Honorable Thomas H. Moore on the Regulatory Alternatives to Address the Flammability of Upholstered Furniture – December 27, 2007.

<sup>10</sup> McCormack J.A., Damant G.H. and Williams S.S. "Flaming Combustion of Upholstered Furniture Ignited by Smoldering Cigarettes", 12th International Conference on Fire Safety, Clarion Hotel - Millbrae, California, January 12, 1987.

<sup>11</sup> Children Playing with Fire: U.S. Experience, 1980 – 1991, John Hall, NFPA, August 1993.

small-open flame typically results in a much more rapid fire process than is seen from the cigarette smoldering process. Depending on the exterior upholstery fabric, ignition of furniture may occur within a few seconds, and fire propagation in the worst cases can result in flashover of the room of origin in as little as 3 minutes. Ignition of furniture by electrical devices may follow a variety of paths, most of which lead to either initial smoldering, or rapid flaming combustion.

The exterior fabric on furniture (the upholstery) potentially plays a very critical role in the initial phase of furniture fires. With respect to cigarette ignition and the potential for furniture smoldering, fabrics made from cellulosic fibers – primarily cotton, rayon and linen - are much more likely to become ignited and start the smoldering process, than are fabrics made primarily from other textile fibers, such as thermoplastics and thermosets. Cellulosic fabrics tend to smolder while man-made fabrics such as polyester, nylon, polypropylene (olefin), acrylic, and modacrylic do not smolder under cigarette ignition conditions, although some localized melting of the fibers may occur from cigarette contact.

The potential for cellulosic fabrics to smolder increases as the weight of fabrics increase. In other words heavyweight cellulosic fabrics are theoretically likely to be a much greater smoldering problem, than are lighter-weight cellulosic fabrics. However, heavy weight cellulosic fabrics tend to be some of the more expensive upholstery fabrics and are typically used on high-end, custom furniture, and are often specified by a design professional. It should also be noted that fire investigations and studies show that furniture fires occur less frequently in the types of affluent homes that are likely to have furniture covered by custom heavy-weight cellulosic fabrics. So the use of the most smolder-prone upholstery fabrics, does not necessarily increase the fire risk from careless use of cigarettes, since such fabrics are typically used in homes where cigarette-caused fires are less likely to occur in any event.

A detailed report, involving cigarette tests of about 1200 pieces of furniture – tested full-scale - has been published.<sup>13</sup> This report looks in detail at the effect of fabric on the smoldering potential of upholstered furniture when ignited by cigarettes. Incidentally, I am unaware that the CPSC has ever performed a similar comprehensive cigarette ignition study of complete articles

---

<sup>12</sup> Patterns of Fire Casualties in Home Fires by Age and Sex, 1986 – 1990, Alison L. Miller, NFPA, June 1993.

<sup>13</sup> Cigarette Ignition of Upholstered Furniture, Damant G.H., Journal of Fire Sciences, Volume 13, No 5, pp. 337-350, September - October 1995.

of furniture during its 35-year investigation into upholstered furniture flammability.

Although the use of thermoplastic-based fabrics is advantageous in resisting smoldering, their performance under flaming ignition conditions is much less stellar. Many thermoplastic fabrics when heated, by even a small open-flame, will immediately melt and rapidly ignite. The ignition and melting of thermoplastic furniture fabrics quickly exposes furniture filling materials (typically materials such as flexible polyurethane foam and polyester fiber batting, which constitute the major fuel load in most furniture) to the burning conditions. Unless the highly flammable filling materials are flame retardant, or are protected by some type of a fire barrier system, the result is often rapid flame development, and the potential for room flashover within minutes.

In contrast, furniture covered by cellulosic fabrics, particularly of medium to heavy fabric weight, are more difficult to ignite by small open-flames; generally burn much more slowly than do thermoplastic fabrics; do not melt; do not quickly expose the furniture filling materials to flames; and often provide a protective carbonaceous barrier over the highly flammable filling materials, that may last for many minutes. In other words cellulosic fabrics are a much safer choice than are many thermoplastic and thermoset fabrics when considering small open flame ignition of furniture. Cellulosic fabrics may not prevent small open-flame ignition of furniture, but many laboratory tests have shown that their use does significantly delay full furniture fire involvement, and can provide many additional minutes for fire detection and suppression, as well as precious and vital additional time for potential victims to escape from a furniture-caused residential fire.

In the mid 1970's the State of California conducted an industry survey of fabrics used on furniture offered for sale in California. At that time about 75% of the fibers used in California furniture fabrics were cellulosic, and the remaining 25% were mostly thermoplastic. The high percentage of cellulosic furniture fabrics in use no doubt related to the significant problem of cigarette ignition reported by fire statistics at that time. About 15 - 20 years later California conducted a similar survey, and the result was quite different. The second survey revealed that about 75% of furniture fabrics were now made predominantly from thermoplastic fibers, and the remainder from cellulosic and other fibers. There is no reason to believe that the results of these surveys would not also reflect the distribution of fibers that would have existed on furniture sold throughout the U.S. in these time periods. The California surveys



showed that over a period of about two decades a remarkable transition had occurred in the types of fibers used in upholstery fabrics. Not surprisingly, over this period fire statistics also showed a marked decline in the number of furniture fires caused by cigarette ignition.<sup>14</sup>

The current CPSC furniture proposal focuses only on cigarette ignition of furniture, except for cases that are considered Type II by the CPSC proposal (for Type II furniture a fire barrier system must be used that is both cigarette and open-flame resistant). Currently it is estimated that about 80 – 85% of furniture fabrics are made from fibers that are thermoplastic or thermoset and generally would not be considered to be Type II. The previously referenced study (Footnote 13), reports that about 95% of furniture covered with fabric containing at least 80 percent of thermoplastic fibers was inherently cigarette resistant. The study further showed that a very high percentage of furniture was cigarette resistant (about 93%) when the upholstery fabric contained as little as 50% of non-cellulosic fibers. In other words a very high percentage furniture with upholstery fabrics containing 50% or greater of thermoplastic fibers is likely to be automatically cigarette resistant, even in the absence of the proposed CPSC standard. Further, it is likely that the CPSC-proposed standard may encourage furniture producers to discard, or severely limit, their use of cellulosic fabrics (many will be Type II and require a fire blocking system), and promote the use of fabrics that are predominantly thermoplastic.

But here's the problem. In general, cellulosic fabrics are much better than fabrics based upon thermoplastic and thermoset fibers with respect to open-flame ignition. The fire hazard of thermoplastic/thermoset fabrics is from open flame. To prevent rapid propagation of furniture fires and protection of highly combustible filling materials, it is the thermoplastic/thermoset fabrics that are the most dangerous and that require the use of a fire barrier system. But the proposed CPSC standard implicitly, if not explicitly, encourages the use of thermoplastic fabrics, and requires a small percentage of cellulosic Type II fabrics to be used with fire barriers. The CPSC proposal seeks to achieve a slight gain in performance from cigarette ignition, at the expense of a potentially creating an increased problem from open-flame ignited furniture fires. From this aspect alone, the CPSC proposal is clearly a backwards step in achieving a true improvement in furniture fire safety. To achieve a real improvement in furniture fire safety, it is the

---

<sup>14</sup> It should be noted that a number of factors were probably also responsible for the decline in cigarette caused furniture fires, such as, but not limited to, increased use of residential smoke detectors, fewer smokers, and the California and UFAC standards for furniture flammability.

thermoplastic/thermoset fabrics that should be used with a fire blocking. However, the CPSC proposal does not require protection of filling materials when used with fabrics that are the greatest danger with regard to small open-flame ignition.

A number of factors contribute to the marked improvement in the cigarette ignition resistance of upholstered furniture in recent years (See footnote 14). In the 1980's and early 1990's the State of California conducted annual surveys of upholstered furniture offered for sale in California.<sup>15</sup> Over an 11-year period California randomly purchased from furniture retailers about 200 articles of furniture each year for the purpose of determining the flammability properties of furniture sold in California. Every piece of furniture was tested full-scale to determine resistance to cigarette ignition – testing was performed in accordance with California Technical Bulletin 116.<sup>16</sup> To measure cigarette resistance, multiple test cigarettes were placed on every furniture location where a cigarette might accidentally lodge. In 1981, the first year of the survey, 60% of the furniture purchased ignited and smoldered when tested by standard cigarettes. The test data for succeeding years are shown in the following table:

<b>Year</b>	<b>Percent of Furniture Ignited by Cigarettes</b>
1981	60
1982	40
1983	36
1984	30
1985	20
1986	12
1987	18
1988	0
1989	2
1990	6
1991	5

<sup>15</sup> Damant G.H. and Nurbakhsh S., "Development of Flammability Standards in California for Upholstered Furniture and Bedding Products for use in Residences and Public Buildings", Flame Retardants '94, Queen Elizabeth Conference Center, London, England, January 26-27, 1994.

<sup>16</sup> California Technical Bulletin 116 – "Requirements, Test Procedure and Apparatus for Testing the Flame Retardance of Upholstered Furniture", January 1980, State of California, Department of Consumer Affairs, Bureau of Home Furnishings and Thermal Insulation.

Even though California TB 116 has been a voluntary requirement in California, the high rate of compliance with it has been impressive. The key factor that resulted in improved cigarette resistance of upholstered furniture sold in California appears to have been the gradual transition from cellulosic upholstery fabrics to fabrics made from thermoplastic and thermoset fibers over this time period. This is a change that was experienced throughout the U.S., and the national reduction of U.S. cigarette-caused fires demonstrated by fire statistics appears to be reflective of the transition to more smolder-resistant fabrics.

Added to the factors already referenced that appear to have contributed to more cigarette-resistant furniture (even in the absence of any CPSC regulatory intervention), we now have the promulgation in many states of requirements that all cigarettes sold be of “low ignition propensity”. At the time of preparation of these comments, the National Fire Protection Association (NFPA) reports that 27 states, representing about 60 percent of the U.S. population, have enacted laws requiring the sale of cigarettes of reduced ignition propensity, with ten states (New York, California, Vermont, Illinois, New Hampshire, Massachusetts, Oregon, Maine, Montana and Kentucky) already having laws in effect.<sup>17</sup>

Even though it is unlikely that cigarettes of reduced ignition propensity will prevent all furniture fires, it is very likely that a high percentage of newly manufactured furniture will be cigarette resistant (even without the CPSC proposal), and that a substantial percentage of furniture currently on the market will be less likely to be ignited by reduced ignition propensity cigarettes once all the state laws are enacted. All of the above factors point to the fact that it is clearly apparent that the current CPSC furniture flammability proposal is “too little – to late”, and that the CPSC proposal fails to address a very serious furniture fire problem – ignition by small open-flame.

#### Flame Retardant Chemicals and Other Fire Safety Improvement Measures

In comments related to an open-flame standard for upholstered furniture the CPSC has recently expressed concern over the potential use of flame retardant chemicals to achieve improved fire safety. CPSC’s suddenly expressed concern on the issue of flame retardants appears to inconsistent with the position that CPSC took just a few months ago while addressing the 16 CFR 1633 flammability standard relating to mattresses and bed sets. During the

---

<sup>17</sup> [www.firesafecigarettes.org](http://www.firesafecigarettes.org)

public comment period for 16 CFR 1633, CPSC received many comments regarding the use of FR chemicals in mattresses. CPSC staff addressed this issue as follows:

“A major concern of consumers commenting on the proposed standard is the use of flame retardant (FR) chemicals in mattresses. At the time the staff conducted its preliminary qualitative assessment for the proposed standard, data on potential exposures to FR chemicals used in mattresses did not exist. Since then the staff has conducted a quantitative risk assessment to provide a more accurate estimate of the potential risk to consumers associated with exposures to these FR chemical/chemical classes in commercially available FR-treated barriers that may be used by mattress manufacturers to meet the draft final flammability standard. Results of the quantitative risk assessment indicate that there are a number of commercially available FR-treated barriers that can be used to meet the staff’s draft final mattress flammability standard. These chemicals are not expected to pose any appreciable risk of health effects to consumers who sleep on treated mattresses”.

“As indicated in the staff’s earlier environmental assessment and confirmed in the updated environmental information, manufacturers appear to have a number of alternatives for meeting the staff’s draft final standard that will not result in unacceptable adverse impacts to human health or the environment. Moreover, government agencies, advocacy organizations, academics, and chemical manufacturers are monitoring and conducting research on the environmental and health impacts of different FR chemicals and other materials. There are regulatory and other mechanisms that can be used to control the use of specific flame retardants if they are ever found to pose unacceptable adverse impacts on human health or the environment.”<sup>18</sup>

In the Executive Summary to 16 CFR 1633 Mattress Briefing Package CPSC staff provided extensive additional documentation regarding “Potential Health Issues Associated with Flame Retardant Use” and “Exposure to Flame

---

<sup>18</sup> Briefing Package – Final Rule for the Flammability (Open Flame) of Mattress Sets, 16 CFR 1633, pages 6 – 7 Executive Summary.

Retardant Chemicals”, as well as devoting one entire section of the Briefing Package (TAB D) to this important issue.<sup>19, 20</sup> It is clear from a review of the 16 CFR 1633 rulemaking that CPSC staff did not have a major concern over the potential use of certain flame retardant chemicals in products that are used for sleeping purposes, and in fact stated in public documents, “These chemicals are not expected to pose any appreciable risk of health effects to consumers who sleep on treated mattresses” and “manufacturers appear to have a number of alternatives for meeting the staff’s draft final standard that will not result in unacceptable adverse impacts to human health or the environment”.

Mattresses, Bed Sets and Upholstered Furniture are not dissimilar products. In fact they are remarkably similar. With the exception of fabric choices used for furniture and mattress applications, and differing geometric configurations, virtually all components (the concealed filling materials, metal springs and wood), are identical. It is therefore fascinating that FR chemicals are found to be acceptable by CPSC, and “not to pose any appreciable risk of health effects to consumers” in one application and for one product, but apparently not the other.

There is a great amount of confusion and misinformation circulating currently about flame retardant chemicals, as well as other chemicals generally associated with usage in a variety of plastics and textile applications. Much of this misinformation is generated by organizations whose agenda is clearly not fire safety, and who appear to have a very little understanding of the science behind many of the chemicals that they allege to be unacceptable. There are many in our society who apparently have no interest or concern about the tragic deaths and debilitating injuries that result from fire, provided that their chemophobic agendas are satisfied.

Today many chemicals, particularly flame retardants, are found “guilty by association”. Because one or two flame retardant chemicals have been found to present an unacceptable risk, many chemicals (sometimes not even closely related chemically) are being implicated by irresponsible organizations whose sole agenda appears to be the spread of chemophobia. CPSC’s apparent position related to the potential use of flame retardants in upholstered furniture does little to alleviate the confusion and misinformation. In fact, it does the

---

<sup>19</sup> Briefing Package – Final Rule for the Flammability (Open Flame) of Mattress Sets, 16 CFR 1633, pages 16 – 17, 22-26, Executive Summary.

<sup>20</sup> Briefing Package – Final Rule for the Flammability (Open Flame) of Mattress Sets, 16 CFR 1633, TAB D.

opposite and plays right into the hands of those who would seek to deprive consumers of safe solutions to serious fire safety problems.

CPSC's position related to the safety to chemicals used for consumer applications needs to be based upon the best science available, and not emotional rhetoric. Fire safety and public health are not an "either/or" situation. To protect the U.S. public we can and must have fire safe products that also provide no health risk. Fire safety and public health are not mutually exclusive, as many of the proponents for banning literally hundreds of chemicals would have us believe.

### Fire Barriers and Fire Blocking Systems

Putting aside the issue of the use, or non-use, of flame retardant chemicals in upholstered furniture applications, in any event their use may not be crucial to improving the open-flame ignition fire performance of upholstered furniture. Since the early 1970's a variety of fire blocking systems, or fire barriers, have been developed by numerous suppliers. Many of these products and materials are specifically intended to improve the fire performance of furnishings. Numerous documents memorializing the development of fire-blocking systems for furnishings have been published.<sup>21,22,23</sup>

The implementation of full-scale fire tests for mattresses, bed sets, and upholstered furniture, such as California Technical Bulletins 121, 129, 133 and 603 and 16 CFR 1633 at the federal level, as well as consensus test methods and standards such as ASTM E 1537, ASTM E 1590, ASTM E 1822, and various NFPA requirements, has resulted in a literal explosion in the development of new and innovative fire barriers for furniture and bedding applications. Most of these fire barrier systems are made from inherently fire resistant fibers, and many of the barrier systems are represented as containing "no flame retardant chemicals". It is important to recognize that most of the inherently FR fibers used in the fire barriers that are currently used in furnishings have been safely used for years in other fire safety applications such

---

<sup>21</sup> Damant G.H., "Use of Barriers and Fire Blocking Layers to Comply with Full-Scale Fire Tests for Furnishings", Fifth Annual Conference on Flame Retardancy - Recent Advances in Flame Retardancy of Polymeric Materials, Stamford, Connecticut, May 24 - 26, 1994.

<sup>22</sup> Damant G.H., "Recent United States Developments in Tests and Materials for the Flammability of Furnishings," **Journal of the Textile Institute**, UK,, Volume 85, Number 4, pp. 505 - 525, 1994.

<sup>23</sup> Damant G.H. "Use of Barriers and Fire Blocking Layers to Comply with Full-Scale Fire Tests for Furnishings," **Journal of Fire Sciences**, Volume 14, No. 1, pp. 3 - 25, January - February 1996.

as fire/heat protective clothing – where they are often in direct contact with the wearer’s skin. Today virtually 100 percent of the mattresses and bed sets sold in the U.S., to comply with the stringent provisions of 16 CFR 1633, incorporate fire barriers in their design. The specific intent of using the fire barriers in mattresses and bed sets is to reduce the likelihood of the fire involvement of mattress filling materials, and to delay the potential for flashover (for example, the mattress standard, 16 CFR 1633, allows only slow controlled burning for the first 30 minutes after ignition, with a limit on the amount of heat that can be released by the burning bed set).

The U.S. furniture industry is no stranger to the use of fire barrier technology. Since 1984 millions of pieces of upholstered furniture have been sold in the U.S. with fire blocking or fire barrier technology. Virtually every piece of furniture sold in the U.S. designed to comply with the provisions of California Technical Bulletin 133 uses a fire barrier system. Although TB 133 is a California standard, its use is widespread throughout the U.S. in contract furniture that is intended for use in a variety of public buildings (other standards such as ASTM E 1537, the Boston standard – BFD IX - 10, and the New York/ New Jersey Port Authority standard are all similar to TB 133).

As indicated above, mattress producers selling in the U.S. have embraced fire barrier technology for use in all residential mattresses and bed sets sold to comply with 16 CFR 1633. The use of fire barriers in bed sets appears to be no impediment to their manufacture or sale. The cost of the barriers has declined markedly as their use has become more common, and barrier suppliers assure us that there is plenty of industry capacity to meet the needs of the furniture industry. Therefore, there appears to be no reason that fire barriers could not be used with great effect in upholstered furniture. Their use in residential furniture would result in a quantum improvement in the fire safety of furniture currently sold for use in consumers homes, and would result in a significant decline in the deaths and injuries that are currently caused by furniture fires. The CPSC is apparently committed to reducing deaths and injuries from unsafe consumer products. Ladies and gentlemen of the CPSC, there is a viable solution to the furniture flammability problem, we need you to embrace it and provide some real leadership on this important fire safety problem. The current CPSC proposal fails to provide the solution that is required.

The frustrating aspect of the current CPSC flammability proposal for upholstered furniture is not only that cigarette ignition resistance is merely a partial and incomplete solution to a significant fire safety problem, but that

solutions to the open-flame ignition resistance of upholstered furniture, including the use of fire barrier technologies, are readily available. There is no reason to believe that the fire barrier products that have been embraced by the mattress industry would not be equally effective in reducing the open-flame fire hazard of residential furniture, and would at a minimum achieve the same objectives that CPSC found persuasive, and embraced, when addressing mattress flammability. Namely prevention of rapid fire involvement of furniture filling materials, and minimizing and/or delaying full-room flashover when an article of furniture is ignited in a typical residential fire. If CPSC found it important to minimize and delay flashover from residential mattresses and bed set fires, why is it not also as important, or even more so, to achieve the same goal and objective with furniture, given the extreme fuel load and fire hazard of much modern furniture? Faced with the currently available technologies for improving the fire safety of furnishings, CPSC's reluctance to address this important fire safety issue is even more baffling and inexcusable. The CPSC's inconsistent approach to this critical fire safety problem leaves much to be desired, and leaves those of us who have been involved in upholstered furniture research, testing or regulation for so many years frustrated and greatly disappointed.

### Validation Testing

It is understood that CPSC plans to perform validation testing to ensure that the proposed furniture flammability mock-up standard will be predictive of furniture fire performance in real scale. Obviously such validation testing is critically important if one is to conclude that the mock-up tests mean anything relating to real-life performance. It is difficult to understand why validation testing was not performed prior to proposing a standard. Surely it would be helpful to know if one is heading in the right direction before proposing a potential solution to a problem. Typically regulatory agencies validate their approach to problems before they formally propose the solution. Such an approach is more economical, provides greater confidence in the proposed solution, and is the right thing to do, scientifically. The current plan by CPSC to conduct validation testing after proposing a standard does not give one a lot of confidence in the CPSC process, and is typical of the convoluted and vacillating approach that CPSC has used to address the furniture flammability problem for the past 35 years.

Full-scale fire tests are also extremely helpful in understanding the nature of a problem. To my knowledge CPSC has done little full-scale fire testing of



upholstered furniture in their attempt to fully understand the furniture flammability problem, or to help in the development of potential solutions. Performing full-scale investigative testing does not mean that the solution needs to be a full-scale test, but it clearly does give one a critical understanding of the nature and dynamics of the fire problems that need to be addressed. Other than a report of 27 full-scale tests in CPSC's 1997 furniture flammability briefing package,<sup>24</sup> which incidentally I found to be of very little value and about which I disagree with CPSC's conclusions, I am unaware of any comprehensive evaluation by CPSC of full-scale performance of upholstered furniture under both cigarette and small open-flame ignition conditions.

### The Potential Impact of CPSC's Proposal on Other Furniture Standards

The Consumer Product Safety Act and the Flammable Fabrics Act (FFA) both address issues related to preemption of local standards. Both of these Acts indicate that state and local jurisdiction standards for products that address the same risk of injury, and that are inconsistent with CPSC standards, are preempted by the standards adopted by the CPSC.<sup>25, 26</sup> Essentially both Acts prohibit a state or local jurisdiction from having a standard for a product that is inconsistent with or not identical to a CPSC standard, that addresses the same risk of injury (or specifically with respect to the FFA if the local standard or regulation is designed to protect against the same risk of injury from occurrence of fire). The Acts do, however, permit States and local jurisdictions to apply for exemption from preemption.

As previously noted, the current CPSC proposal addresses only cigarette ignition of upholstered furniture, and ignores ignition of furniture by other sources, such as an open-flame and electrical devices. However, the State of California has in place residential furniture regulations (since 1975), that address ignition of furniture components and mock-ups by both cigarettes and small-open flames. For 33 years California regulations have required furniture sold in the State to exhibit resistance to both cigarette and open flame ignition when tested by the requirements of Technical Bulletin 117. With the potential

---

<sup>24</sup> Consumer Product Safety Commission, "Regulatory Options Briefing Package – Regulatory Options for Small Open-Flame and Smoking Material Ignited Fires", October 28, 1997.

<sup>25</sup> Consumer Product Safety Act, 15 U.S.C. 2051 – 2084, Section 26 (15 U.S.C. 2075).

<sup>26</sup> Flammable Fabrics Act, 15 U.S.C. 1191-1204, Section 16 (U.S.C. 1203).

adoption of the CPSC furniture proposal, there is the very real threat that the California standards will be preempted.<sup>27</sup>

If the CPSC proposal were equal to, or more stringent than, the existing California standards, preemption would be less of an issue. But that is not the case. While it is true that to some extent, the CPSC's un-validated proposal addresses cigarette ignition of furniture, the open-flame ignition scenario is totally ignored. If the California standards were to be preempted by the CPSC proposal, they would in fact be replaced by a standard that only addresses part of the problem, and which totally ignores the problem of open-flame ignition. In fact it is probably that furniture made to comply with the CPSC proposal might be more susceptible to open-flame ignition, due to an expected transition towards the use of thermoplastic fabrics and away from the medium-to heavy weight cellulosic fabrics that are common to high-end furniture.

The California furniture flammability regulations, in effect since 1975, legally apply only to furniture sold in California. On a demographic basis about 12 – 14 percent of furniture sold in the U.S. is sold in California. However, compliance with the California furniture flammability regulations is far more widespread. Over the last 10 – 15 years, many U.S. furniture producers, including most of the largest U.S. producers, have converted all of their production to be in compliance with the California requirements, irrespective of the point of sale. In addition several large retail chains sell only California-complying furniture throughout the U.S. I estimate that currently 40 – 50 percent of furniture sold in the U.S. is made to comply with the current California furniture flammability standards.

Can CPSC really be serious about proposing a furniture flammability standard that potentially invalidates and preempts a standard that has been embraced by about 50 percent of the furniture industry, without providing an equivalent level of safety, or at least an alternative or additional test method that furniture producers can use to evaluate the small open-flame ignition resistance of their products? Is CPSC able to document that number of furniture fires that did not occur, that were so minor that they were unreported, or that progressed more slowly, because of compliance with current California standards? Can CPSC speak to the number of lives that were saved or injuries prevented because furniture fires were prevented or developed more slowly, or

---

<sup>27</sup> CPSC Advisory Opinions related to CPSC preemption have indicated that the risk of injury from burning products, such as furniture and mattresses, does not depend upon the method or type of ignition. Ignition by cigarettes or open-flame are apparently treated as being the same risk of injury for Federal preemption purposes – Advisory Letter from the CPSC Office of the General Counsel to Thomas W. Power, December 8, 1983.

because residents were given additional time to escape, due to the California standards being in place?

One has to assume that, at least in part, furniture makers voluntarily complied with the California standards because they thought they were making safer furniture, it was the right thing to do, and they wanted to provide their customers with an additional level of safety (concerns related to product liability and the advisability of making uniform products might also be factors). Is CPSC prepared to now tell U.S. furniture makers, that it is all right to discarded the flammability requirements that they have chosen to comply with, and that it satisfactory to sell furniture that may flashover the homes of their customers in 3 – 5 minutes? Does CPSC condone this type of fire performance? Is CPSC willing to inform U.S. consumers that it is OK to buy furniture that may destroy homes, and potentially cause death and injury to their children, in a matter of minutes? For an agency whose mission is one of consumer safety, these options seem egregious and preposterous.

There may be some small incremental benefit to be gained from CPSC's cigarette ignition proposal. But CPSC's failure to address the serious problem of open-flame ignition of furniture, as well as the potential for invalidating a widespread standard that does address open-flame ignition to some degree, is far too great a price to pay. It is ironic that several years ago after developing a proposed revision to California Technical Bulletin 117, the California Bureau of Home Furnishings delayed implementation of the revised standard in a commitment to work cooperatively with CPSC in the interest of developing a comprehensive solution to the U.S. furniture fire safety problem. Perhaps if California had continued to promulgate the revision to TB 117, we would not find ourselves in the unfortunate position that we are in today. Overall it is my opinion that CPSC's cigarette test proposal by itself does not significantly improve U.S. fire safety, and is clearly a step backwards. For that reason alone I am unable to support the CPSC proposal.

At a minimum it is imperative that CPSC not go forward with the current proposal until a comprehensive solution to the serious problem of furniture fire safety has been achieved that addresses both cigarette and small open-flame ignition, as previously voted on and endorsed by the Commission. The cost of losing current standards that do address open-flame ignition of furniture, to at least some degree, due to preemption is too high a price to pay. Hopefully, a comprehensive solution could be achieved within a reasonable time frame and with minimal additional delay, particularly since the CPSC staff

has already developed and published several prior proposals to address open-flame ignition.

### Summary

Most homes contain two primary fuel packages: upholstered furniture and bedding products. U.S. consumers now have the benefit of mandatory fire standards for mattresses and bed sets addressing both cigarette ignition (since 1974), and open-flame (since July 2007). However, U.S. consumers have no such current benefit, outside of California, related to flammability standards for upholstered furniture. The furniture rulemaking has provided the CPSC an opportunity to rectify this serious deficiency.

CPSC's proposed rule does little to address this deficiency in a serious way. In fact the proposed rule, for the reasons stated earlier, may actually be a backwards step in fire safety. Many of us who have followed CPSC's furniture-related activities over the years are greatly disappointed by CPSC's failure to comprehensively address the serious fire safety problems caused by highly flammable furniture. It seems clear the CPSC current proposal is more of a politically acceptable solution than one truly based upon the objective of protecting consumers from the ravages of furniture fires. The societal impact of furniture fires in recent years, involving thousands of deaths, injuries, and extensive property loss has been a national tragedy. About 3,000 victims lost their lives in the World Trade Center tragedy, and the governmental and societal response was impressive. In recent years about 30,000 citizens, many of them young children, have perished in furniture fires. CPSC's response – little more than a band aid.

By its very charter, CPSC has a responsibility to protect consumers from unreasonably dangerous products. For 35 years, CPSC has substantially abdicated that responsibility with respect to furniture flammability. The current proposal does little to make amends. Although it is apparent the CPSC believes that open-flame ignition of upholstered furniture is not a high priority, it is doubtful that the thousands of victims of recent furniture fires and their

families would agree, and certainly those who are on the front lines of fighting furniture related house fires, and who have to cope with the countless victims, have great difficulty in accepting CPSC's failure to comprehensively address this issue.

Many government agencies are faced with severe time constraints when developing standards and regulations. Many agencies are required by law to complete standards, regulations and rulemaking within certain prescribed time periods. It is apparent, based upon the current experience with upholstered furniture, that the CPSC is not limited by any such constraints. However, it is hard to believe that in 1972 when Congress was engaged in producing the Consumer Product Safety Act, it contemplated that the CPSC would spend about 35 years working on a single flammability standard, and then propose a standard that only addresses a portion of the overall problem. Perhaps it is timely that federal legislators are taking a fresh look at the process under which CPSC develops consumer product safety standards.

If the CPSC is really serious about addressing problems associated with the flammability of furniture, it is imperative that a standard addressing both smoldering and flaming ignition be proposed. Anything less is a serious disservice to the consumers that CPSC is charged to protect. More than 30 years of activity on this important consumer safety issue is far too long for any government agency. There has been far too much vacillation on this issue. Far too many lives have been lost, and far too many children and adults have been injured. Now it's time for the agency to take a leadership position by proposing a comprehensive solution to the problem of upholstered furniture flammability. As they say – where there's a will, there's a way.

If there is a positive in the proposed rulemaking, it concerns the well thought out and encouraging comments of Commissioner Thomas Moore. Some of Commission Moore's comments are among the more insightful that I have seen from the CPSC on this issue. I agree with Commissioner Moore that the current proposal could be considered a first step in the process of addressing furniture flammability. But only on two conditions. There must be a commitment at the agency to rapidly and comprehensively address the issue of open-flame ignition, and there must be no preemption of existing standards until CPSC comes up with a viable and scientifically acceptable solution to this vexing problem. Anything less is a disservice to U.S. consumers, and a backwards step in fire safety.

I am also encouraged by recent activity involving Underwriters Laboratories (UL) and the NFPA's Research Foundation to take a fresh look at the open flame ignition of furniture. I have made a personal commitment to assist in this project. Commission staff are currently monitoring this activity. It is critically important that the CPSC remains actively engaged in this project. There have been times in the past when CPSC has displayed a "not invented here" attitude on issues related to consumer product flammability standards. The time for parochialism has long past – fire involving furniture, and other consumer products, is an important issue that has either directly or indirectly affected thousands of lives in recent years. It is time for the CPSC, the furniture industry, other associated trade associations and companies, and other interest parties to become fully engaged in this important issue. Foot dragging and obfuscation on this issue has gone on for far too long. The time has come for all parties make a determined effort to provide consumers with what they have the right to expect – safe furniture products. We can and must do better.

I appreciate the opportunity to provide these comments related to furniture fire safety. I have spent the best part of 40 years working on a variety of issues related to consumer product flammability. This is a consumer product safety issue about which I have strong feelings. Over the years I have had the opportunity to work closely with the Commission on many issues, and have over the past 35 years developed personal friendships with many employees of the Commission. These comments, although genuine and perhaps strong, are not intended to demean any past or current employee of the Commission. It is clear to many of us that Commission employees often work under difficult circumstances and are faced with challenging procedural requirements.

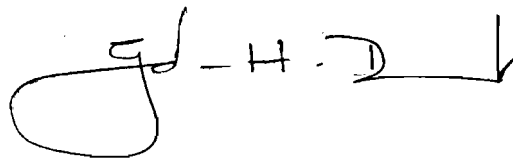
A handwritten signature in black ink, appearing to read "G. H. D." with a stylized flourish on the left and a downward-pointing arrow on the right.

Gordon H. Damant  
Damant & Associates

**Stevenson, Todd**

---

**From:** Gordon Damant [gdamant2@yahoo.com]  
**Sent:** Tuesday, May 06, 2008 11:18 AM  
**To:** CPSC-OS  
**Subject:** Comments on "Upholstered Furniture NPR"  
**Attachments:** Damant Furniture Comments to CPSC - May 2008.doc

Attached are my comments related to the "Upholstered Furniture NPR".

Please contact me with any questions.

Gordon Damant

Damant & Associates

3550 Watt Ave., Suite 5

Sacramento, CA 95821

916-485-7018 Phone

# **GBH International**

**2 Friar's Lane**

**Mill Valley, CA, 94941**

**Tel: 415-388-8278; FAX: 415-388-5546**

**e-mail: [GBHINT@aol.com](mailto:GBHINT@aol.com)**

**Website: [www.gbhinternational.com](http://www.gbhinternational.com)**

## **Comment by GBH International on CPSC NPRM on Upholstered Furniture Flammability**

### **Summary**

The regulation for the flammability of upholstered furniture by means of 16 CFR 1634, as proposed in the Notice of Proposed Rulemaking (Federal Register / Vol. 73, No. 43 / Tuesday, March 4, 2008 / Proposed Rules), is severely flawed and needs to be amended or withdrawn. There are ten reasons for this, as shown below. Further details of each reason will follow, when they are expanded on.

1. The proposed regulation involves testing for smoldering ignition of the upholstered furniture cover fabrics without providing any regulation for the foam or for any other padding or filling contained within the upholstered furniture. This means that any material will be able to be used as padding, filling or foam material within upholstered furniture, even if that material is extremely flammable (such as a flammable solid) or even explosive.
2. The proposed regulation involves testing for smoldering ignition of the upholstered furniture cover fabrics but does not require any flaming ignition testing of fabrics. This means that any fabric without a cellulosic content will be permitted to be used as an upholstered furniture cover fabric, since fabrics that are 100% plastic (typically thermoplastic) will virtually never ignite by smoldering ignition.
3. The proposed regulation involves testing for smoldering ignition of the upholstered furniture cover fabrics but permits fabrics that fail the smoldering test to still be acceptable for use in upholstered furniture if they are placed over a barrier and the barrier meets an open flame test. This means that even fabrics that are ignited by the effect of smoldering cigarettes will be permitted to be used as upholstered furniture cover fabrics.



4. The proposed regulation involves testing for smoldering ignition of the upholstered furniture cover fabrics without providing any regulation for the interior fabrics, barriers (except when used with smoldering cover fabrics), filling materials, deck padding used under loose cushions, decorative trims and welt cords contained within the upholstered furniture. This means that many materials that are not permitted to be used under the voluntary requirements of the Upholstered Furniture Action Council (UFAC), which requires that all of those materials described above are tested, will be permitted to be used within upholstered furniture.

5. The proposed regulation involves testing for smoldering ignition of the upholstered furniture cover fabrics without providing any regulation of the flaming ignition of any material (other than barriers for use with smoldering fabrics) contained within the upholstered furniture. This means that this ignores the key issue in a fire: heat release. Heat release rate is the key factor in determining the fire hazard of upholstered furniture and is a much more important factor in fire safety than is ignitability.

6. The proposed regulation involves testing the cover fabric of the upholstered furniture only. This means that the heat released by the filling materials in upholstered furniture is ignored even though the heat released by the filling materials is much greater than that released by the cover fabrics.

7. The proposed regulation involves testing for smoldering ignition only. This means that upholstered furniture containing materials releasing enormous amounts of heat very rapidly, to such an extent that they can overwhelm sprinkler systems and hurt first responders such as firefighters, will be permitted to be used.

8. The proposed regulation involves regulation of smoldering ignition of cover fabrics only in upholstered furniture, in spite of the fact that the voluntary requirements from the Upholstered Furniture Action Council (UFAC) which require that all residential upholstered furniture component materials be tested for smoldering ignition, have been an important factor in the decrease in fire fatalities associated with upholstered furniture in homes since they were implemented in the 1970s. Additional requirements for smoldering ignition have also been in place for many years as implemented by the state of California and voluntarily followed by many manufacturers: the entire upholstered furniture item (in California Technical Bulletin 116) and all upholstered furniture filling materials (in California Technical Bulletin 117).

9. The proposed regulation involves regulation of smoldering ignition of cover fabrics in upholstered furniture only in spite of the fact that the requirements of the British regulation for the flaming ignition of all components of residential upholstered furniture since the 1980s has resulted in a much more dramatic decrease in the fire fatalities associated with upholstered furniture in homes in Britain compared to statistics in the US.

10. The proposed regulation will have no significant effect in decreasing fire losses resulting from upholstered furniture and may even result in an increase in fire losses, especially fire deaths and injuries.

**Further details:**

1. The proposed regulation contains no requirements for fire performance of any of the filling materials. This means that any filling material can be used. The proposed CPSC test does not require that any filling material to be used in the furniture be assessed at all. In the smoldering test for the cover fabric, a standard polyurethane foam is used and not actual materials from the furniture item to be approved.

One example of a material that can be used as a filling material for upholstered furniture is non flame retarded polyurethane foam. Of course this material is used now. However, we now know that non flame retarded polyurethane foam is a flammable solid in accordance with the CPSC (and fire code) requirements for flammable solids (contained in the US Code of Federal Regulations in section 16 CFR 1500.44) because it ignites easily and burns too fast (see evidence in Attachment 1). This means that more care is needed rather than less care, especially after 14 years of studies on the issue since the National Association of State Fire Marshals' petition. Fire codes do not allow storage of more than 125 pounds of flammable solids per "control area", with control areas required to be separated from one another by fire barriers. The fire codes allow, as an alternative, that the building be constructed as a "hazardous material location", and no homes, stores or warehouses are built like that. Since it is not unusual for one upholstered sofa to weigh 170-200 pounds or more, that means that one sofa can contain enough flammable solid material to exceed the maximum allowable quantity of flammable solids. The fact that fire codes don't apply the regulation to non flame retarded polyurethane foam (or upholstered furniture containing it) is no excuse for continuing to permit the use of such a dangerous product in upholstered furniture without a proper protective barrier.

All toys sold in the US comply with ASTM F 963, "Standard Consumer Safety Specification for Toy Safety", which contains significant levels of safety protection for toys. The requirements are being administered by CPSC with the support of trade associations, including the Toy Industry Association (TIA) and the Juvenile Products Manufacturers Association (JPMA). In fact, TIA stated that "The Toy Industry Association supports Congress' federal legislative efforts to strengthen U.S. toy safety laws and believes a national, unified set of regulations is the best approach to ensure the safety of our nation's children." A key requirement within ASTM F 963 is the protection from lead content in toys. However, ASTM F 963 specification also requires that all toys must pass a flammability test to ensure that they are not flammable solids. The flammability test (contained in 16 CFR 1500.44) from ASTM F 963 applies to any toy at least 1 inch long, with some exceptions. The exceptions are mostly outdoor products, such as bicycles and sporting goods. The specification also specifically excludes furniture. The contrast between the two rules is stark: a stuffed toy cannot contain a block of non flame retarded polyurethane foam that is just over 1 inch long (or has a volume of 1 cubic inch), but a living room

upholstered furniture set can contain blocks of foam that are some 5 feet long (and have volumes of some 11,000 cubic inches)! If the same foam is contained in a mattress it has to be covered by a barrier that resists an open flame (based on the 16 CFR 1633 test). Even more ironic: a child's upholstered chair does not have to be flame retarded but her doll's chair must have flame retarded foam.

The proposed CPSC regulation is silent on the use of any other filling materials, including some that may be extremely dangerous in their own right.

The state of California has had some requirements for both smoldering and flaming ignition of all components of upholstered furniture for many years, with California Technical Bulletin 117. Even though that regulation is not enough to provide fire safety it is much better than what is being proposed by CPSC in that it guarantees that very dangerous materials cannot be used as filling materials.

The state of California has also had a requirement for many years, in California Technical Bulletin 116, that the actual upholstered furniture item be tested for smoldering ignition. This also offers some added safety protection, when compared to the simple use of a standard foam only, since it would show whether the actual combination of cover fabric and fillings can resist smoldering ignition.

2. The proposed CPSC regulation contains no requirements for flaming ignition requirements of the cover fabrics. This means that fabrics that ignite very easily from a dropped match or lighter will be able to continue to be used for upholstered furniture.

Work conducted by researchers in the cotton industry (Wakelyn et al., Attachment 2) have shown that fabric modifications made so that a cellulosic (such as cotton) fabric is less susceptible to smoldering ignition will not result in improvements in the performance of the fabric with regard to flaming ignition. Thus the proposed regulation will do nothing to protect against flaming ignition of cellulosic (cotton-based) fabrics.

Work conducted by many researchers has shown that fabrics which have no cellulosic content will practically never ignite by the effect of smoldering ignition sources, such as cigarettes (see for example Attachments 3-4). That means that virtually any fabric that is not cellulosic will be able to be used as a cover fabric for upholstered furniture.

The regulation in 16 CFR 1610, for apparel fabrics, involves a very small open flame test. This test is extremely mild and its requirements can be met by almost all fabrics, with some exceptions: raised surface fabrics and very lightweight fabrics can fail the test. In fact the test has been credited with protecting people, particularly children and the elderly, from suffering burns when their clothes catch fire (see Attachment 5). The proposed regulation would permit the use of fabrics that are banned from use in apparel.

3. The proposed CPSC regulation involves testing for smoldering ignition of the upholstered furniture cover fabrics but permits fabrics that fail the smoldering test to still be acceptable for use in upholstered furniture if they are placed over a barrier and the barrier meets an open flame

and a smoldering test. This means that even fabrics that are ignited by the effect of smoldering cigarettes will be permitted to be used as upholstered furniture cover fabrics.

The flaming ignition test for barriers is a butane open flame test in which none of the materials intended for use in the upholstered furniture item, other than the barrier itself, are tested. The barrier is tested between a standard foam and a standard cover fabric. The smoldering ignition test is also conducted without using the cover fabric intended for use to see whether the fabric and barrier combination would be ignited by cigarettes. This failure is important since the preliminary test has already shown that the fabric itself will be ignited by cigarettes. Therefore, there is no guarantee that the cover fabric/barrier/foam combination will not undergo smoldering ignition.

4. The proposed CPSC regulation involves testing for smoldering ignition of the upholstered furniture cover fabrics without providing any regulation for the interior fabrics, barriers (except when used with smoldering cover fabrics), filling materials, deck padding used under loose cushions, decorative trims and welt cords contained within the upholstered furniture. This means that many materials that are not permitted to be used under the voluntary requirements of the Upholstered Furniture Action Council (UFAC), which requires that all of those materials described above are tested, will be permitted to be used within upholstered furniture.

The UFAC set of tests includes tests for interior fabrics, barriers (except when used with smoldering cover fabrics), filling materials, deck padding used under loose cushions, decorative trims and welt cords contained within the upholstered furniture. The same tests are also included in the ASTM E 1353 and NFPA 260 standards. By CPSC choosing not to require any of the additional tests it provides lower safeguards than the voluntary safeguards that the furniture industry has had in place since the 1970s.

The UFAC voluntary flammability requirements are being complied with by 117 furniture manufacturing companies which are members of UFAC, as shown on their web site (see Attachment 6). It is likely that additional manufacturers also comply, without paying the UFAC dues. This means that a very large fraction of the manufacturers (probably the vast majority) who sell upholstered furniture in this country are complying with regulations that protect more than the proposed CPSC regulation would do.

5. The proposed regulation does not involve testing for flaming ignition of any upholstered furniture material (other than barriers for use with smoldering fabrics). This means that the proposed regulation ignores the key issue in a fire: heat release. Heat release rate is the key factor in determining the fire hazard of upholstered furniture and is a much more important factor in fire safety than is ignitability. Attachment 7, work by V. Babrauskas and R. Peacock, explains why heat release rate is the most important fire safety issue.

As explained by Babrauskas and Peacock, the effect of doubling the heat release rate of one upholstered furniture item in a standard room is that the survival time is reduced by a factor of more than three times (from > 600 seconds to just 180 seconds). On the other hand, if the time required for furniture ignition is doubled it has virtually no effect on survival time.

It has been shown by a significant amount of work that a single upholstered furniture item can release enough heat to get a room to flashover. Flashover is “a stage in the development of a contained fire in which all exposed surfaces reach ignition temperatures more or less simultaneously and fire spreads rapidly throughout the space.” As explained by NFPA 555, Guide on Methods for Evaluating Potential for Room Flashover, flashover occurs when the surface temperatures of combustible contents rise, producing pyrolysis gases, and the room heat flux becomes sufficient to heat all such gases to their ignition temperatures. In a small room (similar to a typical bedroom) flashover occurs when heat is released at a rate of 1,000 kW (1 MW); typical upholstered furniture items often exhibit heat release rates that are much higher than that, with values of 2-5 MW being quite typical (see Attachments 8-11).

7. Upholstered furniture items such as the ones that caused the fire in the furniture warehouse in Charleston, SC, on June 18, 2007, will still be allowed.

In that 2007 fire “An inferno raced through a Charleston, South Carolina, furniture warehouse, collapsing its roof and killing nine firefighters” in “the single greatest loss of American firefighters in the line of duty since the September 11, 2001, attacks” where “the fire quickly spread throughout the building, which collapsed less than 30 minutes after the blaze began.” Later investigations (which are proprietary with results that cannot be made public) have shown that multiple upholstered furniture items in a storage or display facility release enormous amounts of heat very rapidly, to such an extent that they can overwhelm sprinkler systems. These materials and products would still be permitted if the proposed regulation is approved. They will endanger the lives of our first responders, namely our firefighters.

8. The proposed regulation does nothing more (and perhaps even less) than the voluntary requirements of the Upholstered Furniture Action Council (UFAC), which includes required tests for testing of all residential upholstered furniture component materials and not just the cover fabric. Evidence shows that the UFAC requirements have been an important factor in the decrease in fire fatalities associated with upholstered furniture in homes since it was implemented in the 1970s.

Moreover, the state of California introduced, in 1980, regulations for all upholstered furniture items sold in the state, in California Technical Bulletins 116 and 117. These regulations have been voluntarily adopted by many furniture manufacturers countrywide. CA TB 116 requires that all upholstered furniture items themselves to resist smoldering ignition, and thereby tests the cover fabric in combination with the actual filling and barrier materials used (and not the cover fabric alone). CA TB 117 tests all filling materials for smoldering

ignition and also contains flaming ignition tests. The California requirements provide a level of resistance to smoldering ignition comparable to that in the UFAC voluntary guidelines.

Some statistics are found in Attachment 12 and in NFPA statistics. In 1982, 20.1% of all civilian fire fatalities in the USA started with the ignition of upholstered furniture; a number that has remained fairly steady: 18.2% in 1994-1998, and 19.0% in 1999-2002. Smoking materials (comprising cigarettes, matches and lighters) have been associated with starting upholstered furniture fires leading to 449 deaths in 1994-98, 336 deaths in 1999-2002 and 300 deaths in 2002-2005. Four key factors are associated with the improvements: (a) the smoldering cigarette standards (a mandatory 16 CFR 1632 introduced for mattresses in 1973 and the voluntary UFAC standard for upholstered furniture introduced in the late 1970s), (b) the implementation of California Technical Bulletins 116 and 117 in 1980, (c) the decrease in cigarette smoking and (d) the increased penetration of residential smoke detectors. NFPA statistics indicate that smoking-related home fires starting in upholstered furniture have declined by 87% from 1980 to 2005. The number of upholstered furniture fires that started with cigarettes was almost 25,000 in 1980, while it was only some 11,000 for all other ignition sources combined. By 2004, the number of upholstered furniture fires starting with cigarettes was down to under 2,000 and was significantly lower than those for other ignition sources.

Therefore, it appears that the voluntary UFAC system and the California requirements are having an effect on cigarette initiated fires. In order for the proposed CPSC regulation to further reduce the incidence of cigarette-ignited fires, it must be adequately demonstrated that the proposed smoldering ignition test of the cover fabric is more stringent than what is currently in use. That has not been done and, in fact, it is extremely unlikely that even the upholstered furniture smoldering fire losses will be severely affected by the proposed regulation

Some major reasons why upholstered furniture items are still being ignited by cigarettes appear to be: (a) upholstered furniture lasts for many years, (b) older upholstered furniture items tend to migrate to homes in lower socio-economic strata, where fires are more frequent, (c) many of the non compliant items are imports, and (d) cushions, blankets and other fabrics are often draped on furniture (especially old and used items) and, if they are cellulosic fabrics, they will be susceptible to smoldering ignition. It is unlikely that introducing the proposed mandatory requirements will have a significant effect on these reasons.

9. The proposed regulation involves only requirements for smoldering ignition of cover fabrics in upholstered furniture, while the requirements of the British regulation for the flaming ignition of all components of residential upholstered furniture since the 1980s has resulted in a much more dramatic decrease in the fire fatalities associated with upholstered furniture in homes in Britain compared to statistics in the US..

Data from a study conducted for the British government (Department of Trade and Industry, Attachment 13) shows that the fire fatalities in the UK are much lower than those in the US for fires where upholstered furniture is the item first ignited (see Table 1, with some data updates to 2004). The decreases are primarily associated with the changes in fire safety

requirements for upholstery in the UK. The results clearly show that the decrease in fire fatalities per capita in the UK was very fast over the first 10 years following the UK fire safety regulations (introduced in 1988), and is continuing. The US fire fatality rate (which was not much larger than the UK one in 1988) has decreased much more slowly. The UK fire losses are almost completely associated with old furniture, since there are so few fires where the material first ignited is “combustion-modified foam upholstery”. Table 2 shows that there were only two fire fatalities associated with upholstered furniture using “combustion-modified foam upholstery” between 1996 and 2002. In the US, where upholstered furniture does not use “combustion modified foam”, the associated fires and fire fatalities are much higher, as shown in Table 3.

Year	UK Population (millions)	US Population (millions)	Fire Fatalities per Million UK	Fire Fatalities per Million US
1988	57.0	245.8	3.4	3.9
1997	58.9	267.8	1.5	2.5
2002	60.2	287.6	1.1	1.7
2004	59.8	> 285	0.1	> 1.5

It is worth pointing out that the decreases in fire incidents and fire fatalities in the UK have led to a significant amount of economic savings by the society, as shown in Table 4. The data, for upholstered furniture only, come from the study commissioned by the UK Department of Trade and Industry which looked at the effects of the 1988 legislation in terms of lives saved, decreased number of injuries and economic impact. The study indicated that 710 lives (and over £5 billion) were saved over a 10 year period, in spite of the relatively low smoke detector penetration into the UK at the time. The report also stated: “In addition where fire started in another item but involved upholstered furniture in the house, furniture complying with the Regulations will not catch fire as quickly as non-compliant furniture, thus allowing occupants more time to escape from a fire. This is particularly relevant where smoke alarms detect the fire early. These additional benefits could mean that the actual number of lives saved could be as high as 1860 in the period from 1988 to 1997.” In fact, a follow-up UK study showed that neither smoke detector penetration nor the changes in smoking patterns could explain the improvement in fire losses. A further particularly important economic aspect revealed by the UK study is the fact that the increased cost to industry of developing and selling products with greatly improved fire performance was not passed on to the consumer. In fact prices of upholstered furniture during the period studied increased at the same rate as those of other household products, or of inflation.

<b>Table 2. Fire Losses in the United Kingdom</b>			
<b>When the Material First Ignited is "Combustion-Modified Foam Upholstery"</b>			
<b>Year</b>	<b>Fires</b>	<b>Fire Fatalities</b>	<b>Fire Injuries</b>
1994	0	0	0
1995	Not available	Not available	Not available
1996	1	0	0
1997	7	0	5
1998	14	0	2
1999	8	1	1
2000	13	0	3
2001	41	1	9
2002	58	0	19
<b>Total</b>	<b>142</b>	<b>2</b>	<b>39</b>

**Table 3. US Fire Losses in Homes Where Upholstered Furniture is the Item First Ignited**

<b>Year</b>	<b>Fires</b>	<b>Fire Fatalities</b>
1980	36,850	1,356
1981	33,830	1,360
1982	27,480	1,185
1983	24,560	1,099
1984	24,080	1,093
1985	23,110	931
1986	22,120	1,068
1987	20,760	1,030
1988	20,180	1,098
1989	18,050	883
1990	16,360	867
1991	16,160	676
1992	15,190	631
1993	14,330	653
1994	13,970	669
1995	13,300	659
1996	12,790	652
1997	11,800	655
1998	11,580	543
1999	11,000	472
2000	10,320	632
2001	9,490	639
2002	8,840	502



Table 4 - Benefits Resulting From UK Upholstery Regulations up to 1997			
Benefit measure	Annual benefit		Cumulative benefit 1988-1997
	1992	1997	
Number of dwelling fires	3,715	8,769	42,754
Total lives saved	169	362	1,856
Lives saved for upholstery as item first ignited	65	138	710
Total non-fatal injuries saved	1,548	3,315	17,000
Injuries saved for upholstery as item first ignited	526	1,126	5,774
Loss adjusted cost saving £m/yr	23	53	249
Final cost saving £m/yr	507	10,835	5,567
Total cost saving £m/yr	530	1,138	5,615

Note: the exchange rate between the £ and the \$ is approximately 2 in April 2008.

10. The proposed regulation will have no significant effect on decreasing fire losses resulting from upholstered furniture and may even result in an increase in fire losses, especially fire deaths and injuries.

At the February 2008 International Code Council fire code development hearings it was proposed to protect US consumers from being exposed to new upholstered furniture items with non flame retarded polyurethane foam, by having all such furniture either meet the California Technical Bulletin 133 (or its equivalent ASTM E 1537) test or have the foams meet the British Standard BS 5852 crib 5 fire test. This was not approved. The upholstered furniture retail industry proposed that any store displaying or selling upholstered furniture must be sprinklered. This was approved. This is clearly nothing but a baby step forward, since (a) it has been shown that having a large numbers of upholstered furniture items burning in one store will overwhelm many sprinkler systems and (b) each individual item will burn vigorously once it gets into a home (and very few homes are sprinklered). It was interesting, however, that these proposals caused significant debate.

Calculations indicate that over 8,000 Americans have died in fires starting with upholstered furniture since the National Association of State Fire Marshals petitioned CPSC to institute a mandatory flaming ignition requirement. Furthermore CPSC is responsible for the implementation of the Flammable Fabrics Act (FFA) (passed in 1953 to regulate the manufacture of highly flammable clothing, such as brushed rayon sweaters and children's cowboy chaps, amended in 1967 to expand its coverage to include interior furnishings) since it was created in 1972. This means that CPSC is responsible for regulating the manufacture of foams and other highly flammable materials used in interior furnishings, such as upholstered furniture. Since CPSC has undertaken this responsibility, about 30,000 Americans, many of them children, and a large number of firefighters (such as the 9 victims of the June 2007 Charleston upholstered furniture warehouse fire) have lost their lives in fires that started in upholstered furniture products.

It is also of interest that CPSC granted the NASFM petition, in theory, while not acting in practice. The recent NPRM in fact has CPSC reversing itself and denying the NASFM petition to act on regulation of flaming ignition of upholstered furniture. It is to be hoped that CPSC will reverse itself again and act in the interest of public safety and regulate the flaming ignition of upholstered furniture.



---

Dr Marcelo M. Hirschler