

Crash-Type Manual for Bicyclists

by Carol Tan

FOREWORD

Approximately one out of six highway fatalities in the United States is a bicyclist or pedestrian each year. Estimates for 1995 indicate that 61,000 bicyclists were injured and 830 were killed in traffic crashes. These crashes can be classified or "typed" by their precipitating actions, predisposing factors, and characteristic populations and/or location that can be targeted for intervention.

The information provided in the following guide is the result of a Federal Highway Administration (FHWA) research study that applied the basic National Highway Traffic Safety Administration (NHTSA) bicycle and pedestrian typologies to a sample of bicycle-and pedestrian-motor vehicle crashes from six States with the purpose of refining and updating the crash type distributions. Particular attention was given to roadway and locational factors in order to identify situations where engineering, educational, and/or regulatory countermeasures might be effectively implemented to reduce the frequency of the crashes.

This informational guide should be of interest to State and local bicycle and pedestrian coordinators, transportation planners, and transportation engineers involved in safety and risk management. Other interested parties include those in education, enforcement, and the medical profession.

Pub No. FHWA-RD-96-104

This work was done by the University of North Carolina Highway Safety Research Center.

Manual Index

- [Ride Out At Residential Driveway](#)
- [Ride Out At Commercial Driveway](#)
- [Ride Out From Sidewalk](#)
- [Ride Out At Midblock](#)
- [Ride Out At Stop Sign](#)
- [Trapped](#)
- [Multiple Threat](#)
- [Drive Out At Midblock](#)
- [Drive Out At Stop Sign](#)
- [Unknown](#)
- [Right On Red](#)
- [Backing](#)
- [Drive Through](#)
- [Motorist Overtaking Failed To Detect](#)
- [Motorist Lost Control](#)
- [Motorist Overtaking - Counteractive Evasive Actions](#)
- [Motorist Overtaking - Misjudged Passing Space](#)
- [Motorist Overtaking - Bicyclist Path Obstructed](#)
- [Bicyclist Left Turn In Front Of Traffic](#)
- [Bicyclist Left Turn - Facing Traffic](#)
- [Bicyclist Lost Control](#)
- [Bicyclist Right Turn](#)
- [Motorist Left Turn In Front Of Bicyclist](#)
- [Motorist Left Turn - Facing Bicyclist](#)
- [Motorist Right Turn](#)
- [Uncontrolled Intersection - Other](#)

- Wrong Way Bicyclist
- Bicyclist Overtaking
- Wrong Way Motorist
- Non-Roadway
- Drive Out From On-Street Parking
- Weird
- Motorist Overtaking - Other
- Play Vehicle
- Bicyclist Strikes Parked Vehicle
- Drive Out At Intersection - Other
- Ride Out At Intersection - Other
- Controlled Intersection - Other

Ride Out At Residential Driveway

Frequency: 153 cases; 5.1% of all crashes
Severity: 24% resulted in serious or fatal injuries

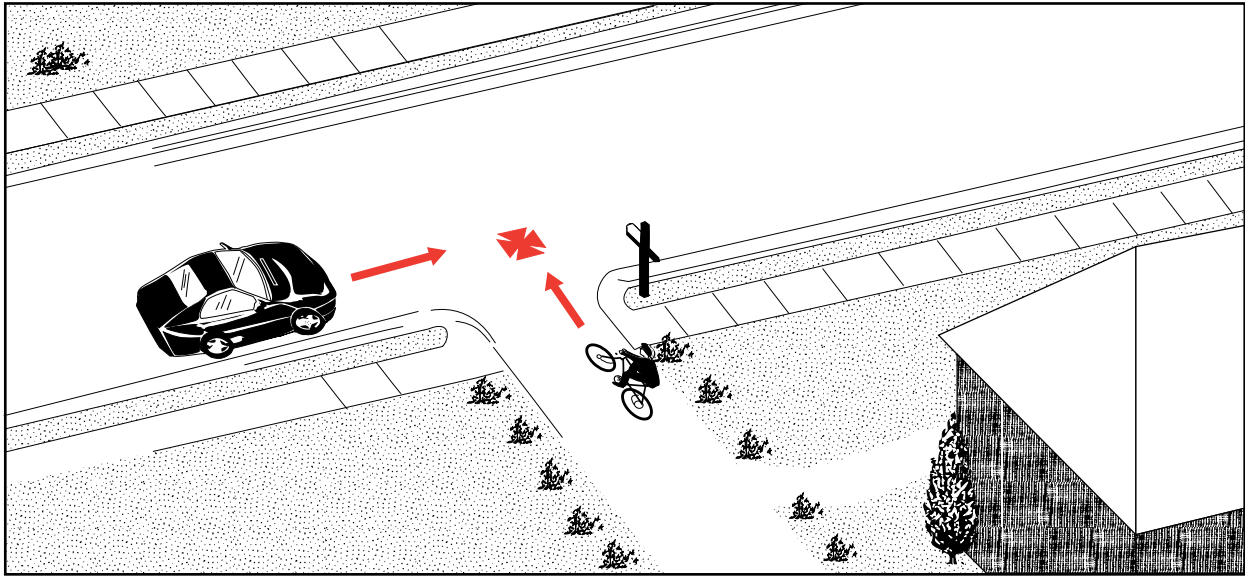

Description: The bicyclist entered the roadway from a residential driveway or alley.

Summary: In comparison to all crashes, this crash was more likely to involve child (age 0 to 9) bicyclists who accounted for more than 1/2 of these events. Child and youth (age 10 to 14) combined accounted for 85 percent.

More than 90 percent occurred on two-lane roads.

A parked vehicle was a vision obstruction in 11 percent. “Other” vision obstructions were present in an additional 10 percent. Thus, more than one in five of these crashes involved some type of vision obstruction.

This crash tended to be slightly more severe than the average.

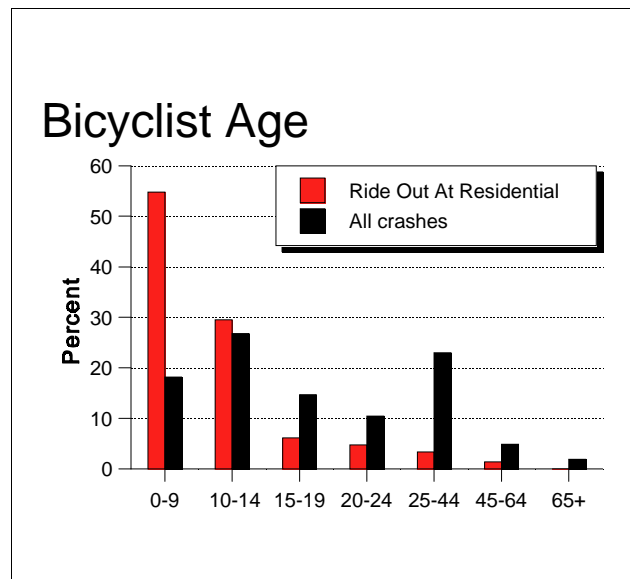
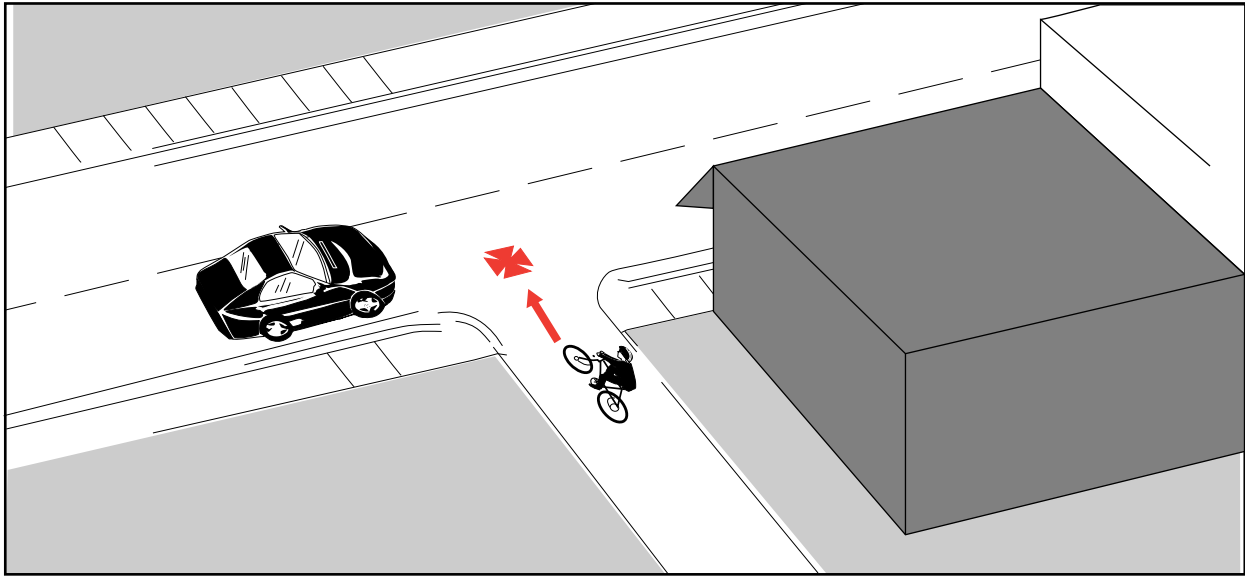

Figure 74. Bicyclist age in “Ride Out At Residential Driveway.”

Ride Out At Commercial Driveway

Frequency: 68 cases; 2.3% of all crashes
Severity: 22% resulted in serious or fatal injuries



Description: The bicyclist was entering the roadway from a commercial driveway.

Summary: In comparison to all crashes, this crash was more likely to involve younger bicyclists, particularly youths (age 10 to 14).

The light condition, number of lanes, and speed limit variables closely followed the results for all crashes combined.

A moving or stopped vehicle was a vision obstruction in 8 percent of these crashes. Overall, there was some type of vision obstruction in 16 percent.

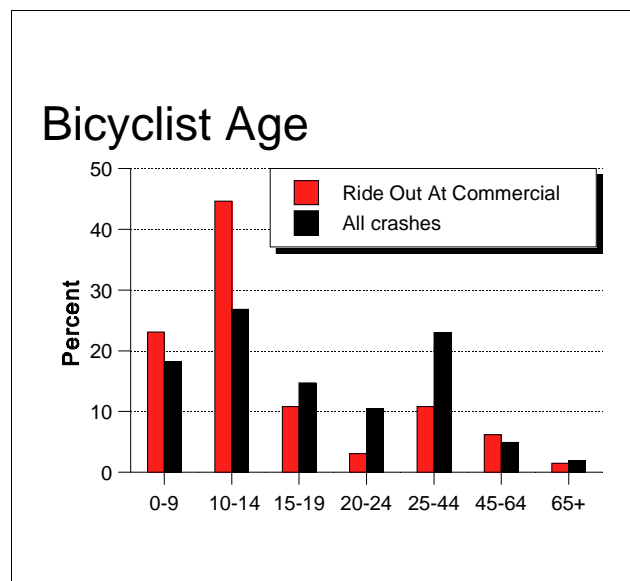
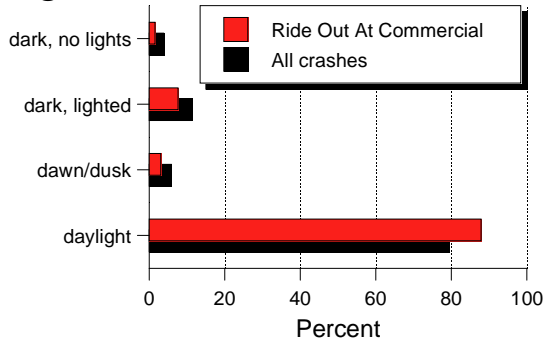

Figure 77. Bicyclist age in “Ride Out At Commercial Driveway.”

Ride Out At Commercial Driveway

Light Condition



Number of Lanes

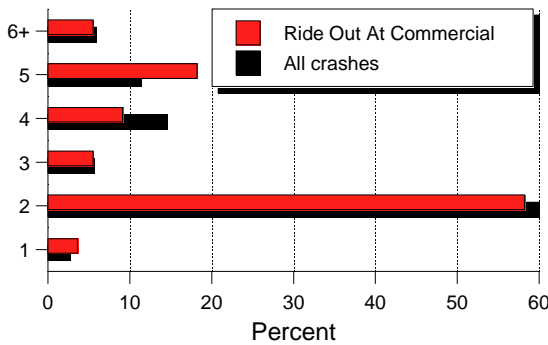

Speed Limit (km/h)

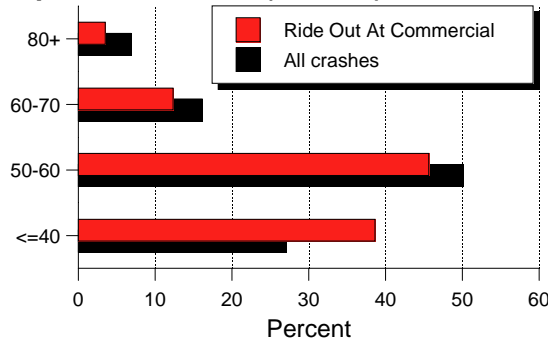

Figure 78. Light condition, number of lanes, and speed limit in “Ride Out At Commercial Driveway.”

Development Character

- ▶ Urban 71%
- ▶ Rural 29%

Traffic Control

- ▶ None 91%
- ▶ Stop Sign 6%
- ▶ Other 3%

Positions

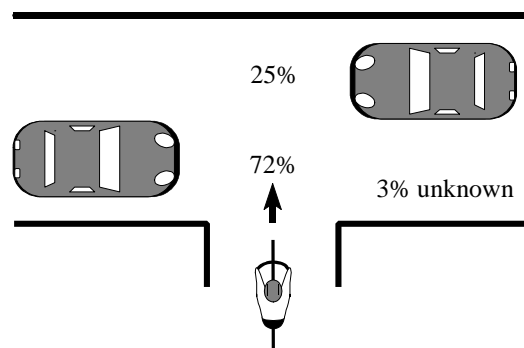

More than 7 out of 10 bicyclists were struck in the first half of the roadway.

Figure 79. Positions in “Ride Out At Commercial Driveway.”

Ride Out From Sidewalk

Frequency: 21 cases; 0.7% of all crashes
Severity: 18% resulted in serious or fatal injuries

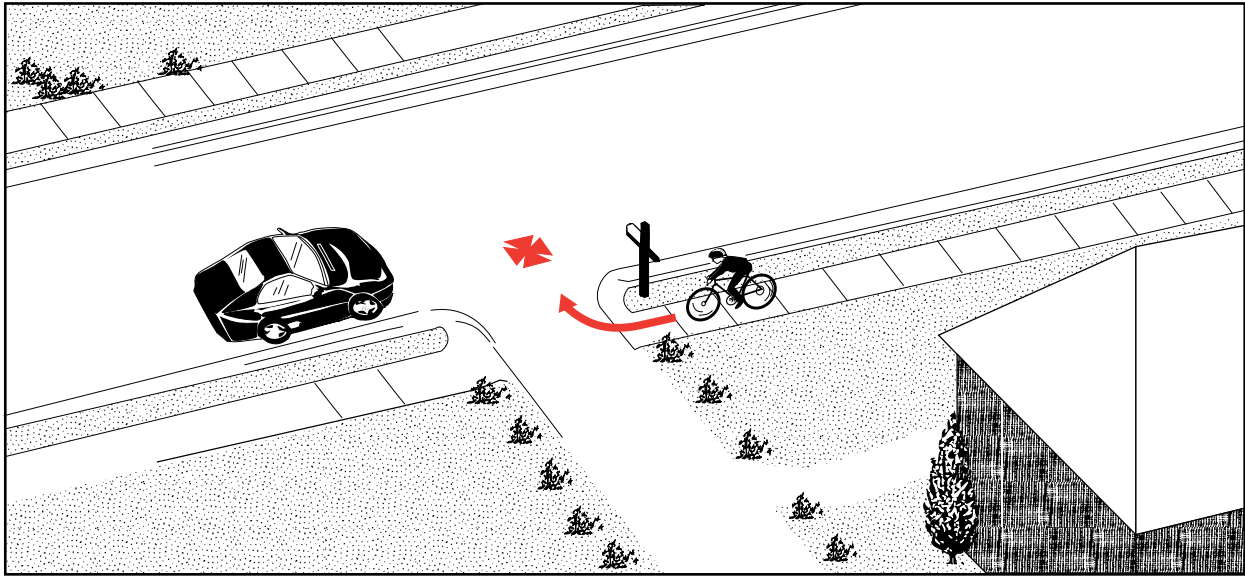

Description: Initially riding along a sidewalk, the bicyclist entered the roadway from a driveway or alley cut.

Summary: In comparison to all crashes, this crash was more likely to involve child (age 0 to 9) and youth (age 10 to 14) bicyclists. More than half of these crashes occurred on streets with a speed limit of 40 km/h or less.

Seventy percent were on 2-lane roads.

More than 75 percent happened in urban areas and 90 percent under daylight conditions.

About 70 percent of the bicyclists were riding on the sidewalk facing traffic.

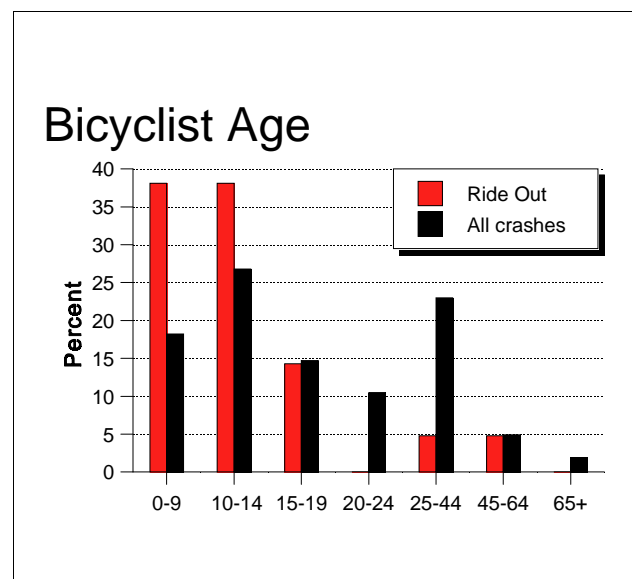
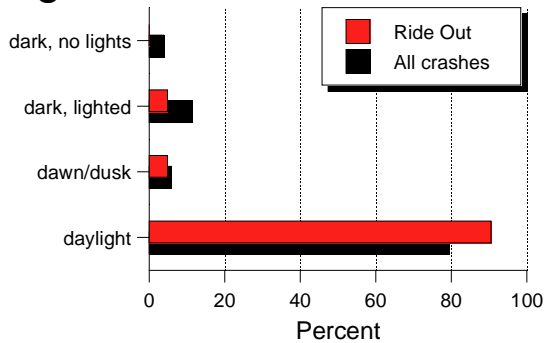

Figure 11. Bicyclist age in “Ride Out From Sidewalk.”

Ride Out From Sidewalk

Light Condition



Number of Lanes

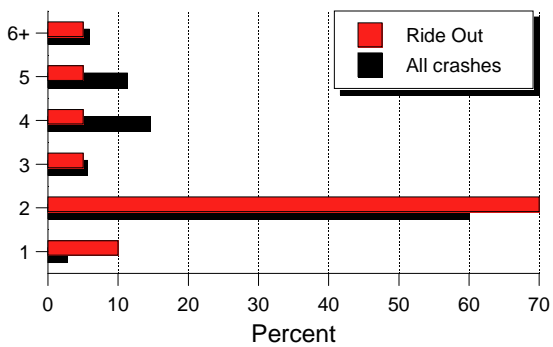

Speed Limit (km/h)

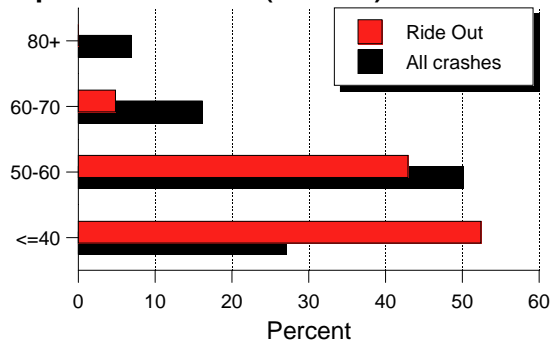
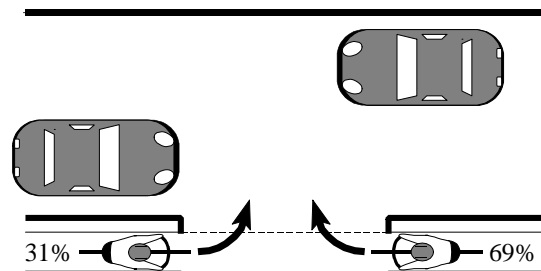

Figure 12. Light condition, number of lanes, and speed limit in “Ride Out From Sidewalk.”

Development Character

- ▶ Urban 77%
- ▶ Rural 23%

Positions



Almost 7 out of 10 bicyclists were riding facing traffic when on the sidewalk.

Figure 13. Positions in “Ride Out From Sidewalk.”

Ride Out At Midblock

Frequency: 132 cases; 4.4% of all crashes
Severity: 20% resulted in serious or fatal injuries

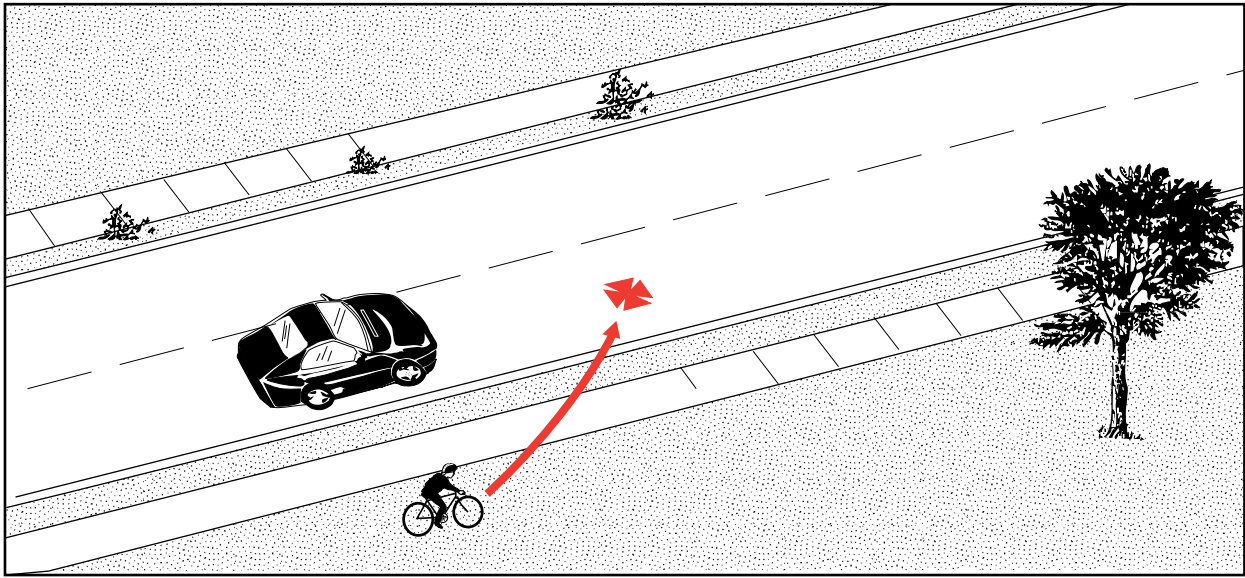

Description: The bicyclist entered the roadway at a shoulder or curb midblock location.

Summary: In comparison to all crashes, this crash was more likely to involve child (age 0 to 9) bicyclists.

A parked vehicle was a vision obstruction in 9 percent of these crashes and a moving or stopped vehicle in 8 percent. Including other vision obstructions, almost one in five of these events had some form of vision obstruction. In addition, 8 percent occurred on a curve in the roadway.

Forty-five percent of adult bicyclists age 25 and older had been drinking.

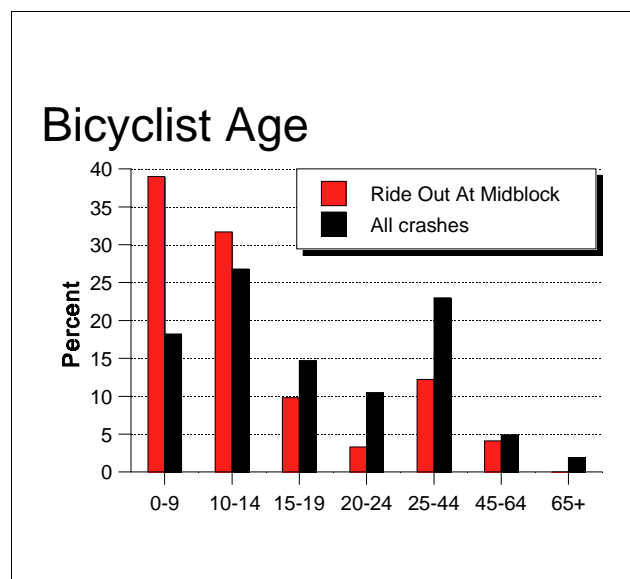
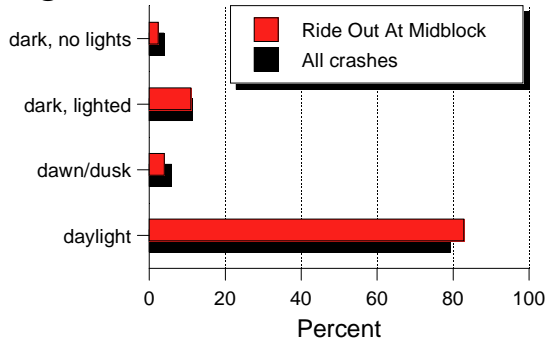

Figure 80. Bicyclist age in “Ride Out At Midblock.”

Ride Out At Midblock

Light Condition



Number of Lanes

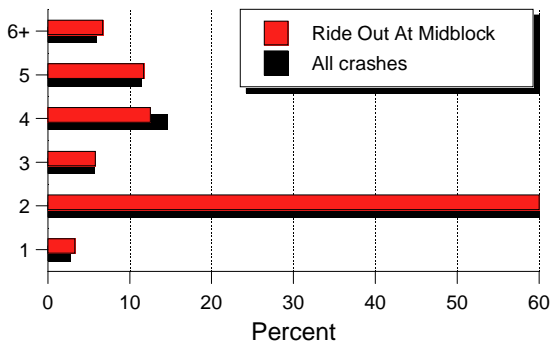

Speed Limit (km/h)

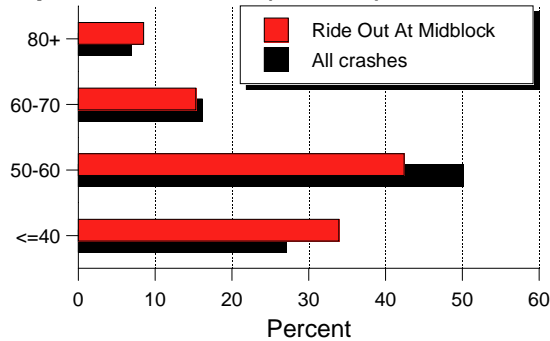

Figure 81. Light condition, number of lanes, and speed limit in “Ride Out At Midblock.”

Development Character

- ▶ Urban 63%
- ▶ Rural 37%

Positions

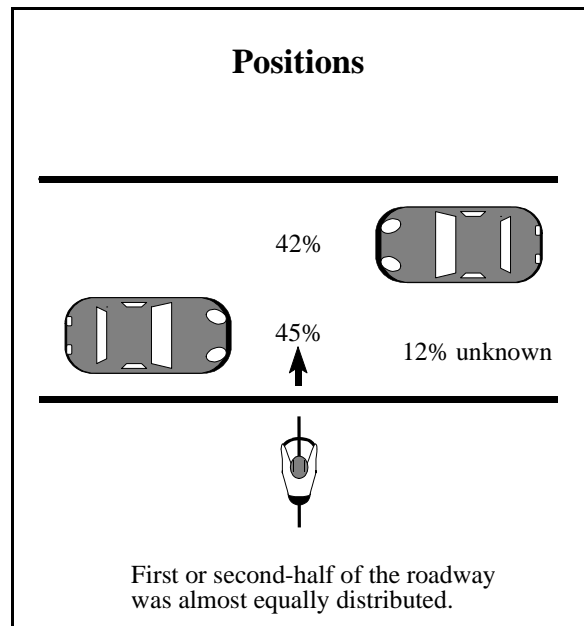
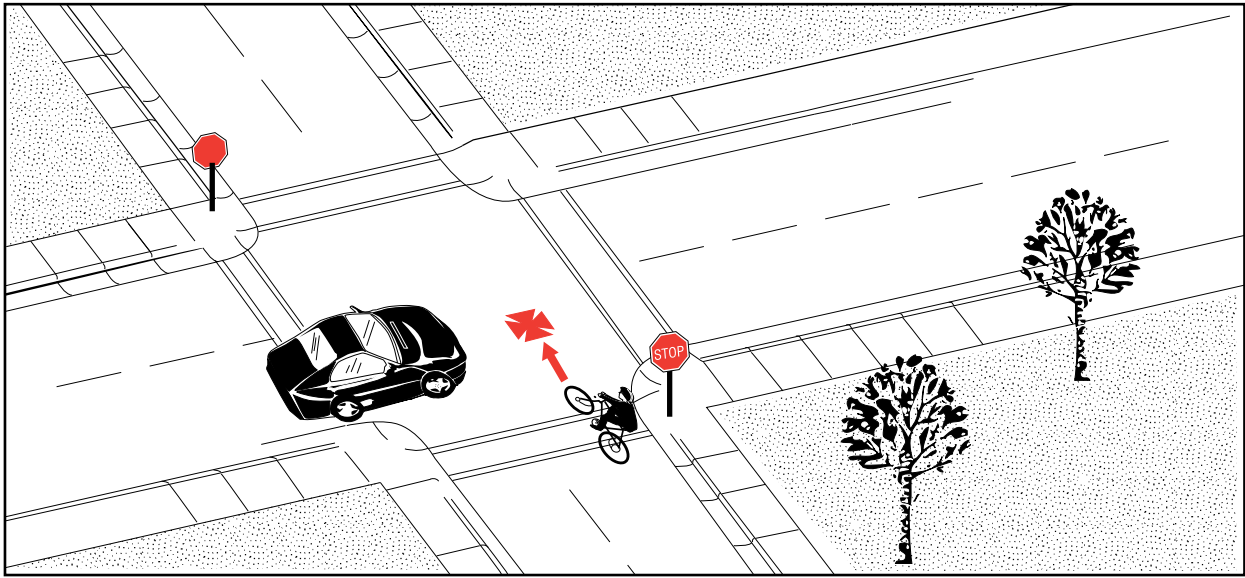

Figure 82. Positions in “Ride Out At Midblock.”

Ride Out At Stop Sign

Frequency: 290 cases; 9.7% of all crashes
Severity: 23% resulted in serious or fatal injuries



Description: The crash occurred at an intersection at which the bicyclist was facing a stop sign or flashing red light.

Summary: In comparison to all crashes, this crash was more likely to involve child (age 0 to 9) and youth bicyclists (age 10 to 14).

Eighty-six percent took place on two-lane roads, and 88 percent were on roads with speed limits less than 60 km/h.

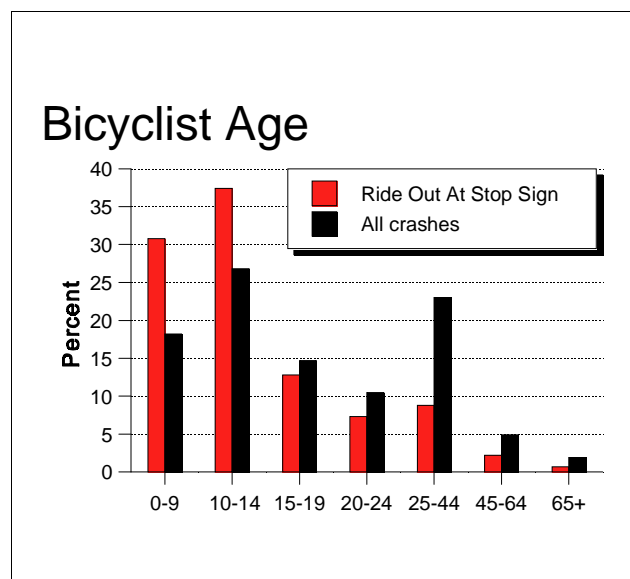
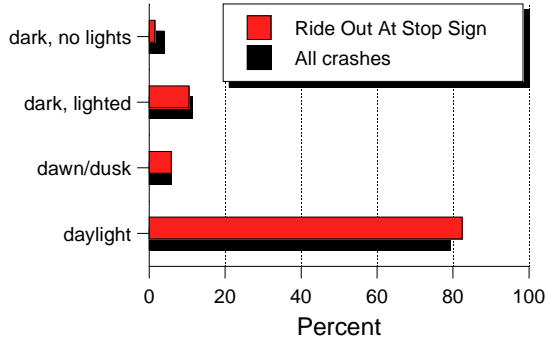

Figure 83. Bicyclist age in “Ride Out At Stop Sign.”

Ride Out At Stop Sign

Light Condition



Number of Lanes

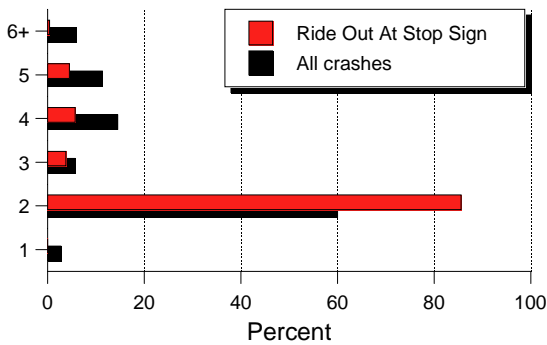

Speed Limit (km/h)

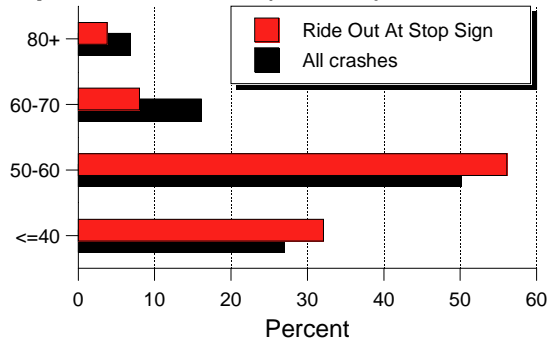

Figure 84. Light condition, number of lanes, and speed limit in “Ride Out At Stop Sign.”

Development Character

- ▶ Urban 72%
- ▶ Rural 28%

First-half of Roadway Positions

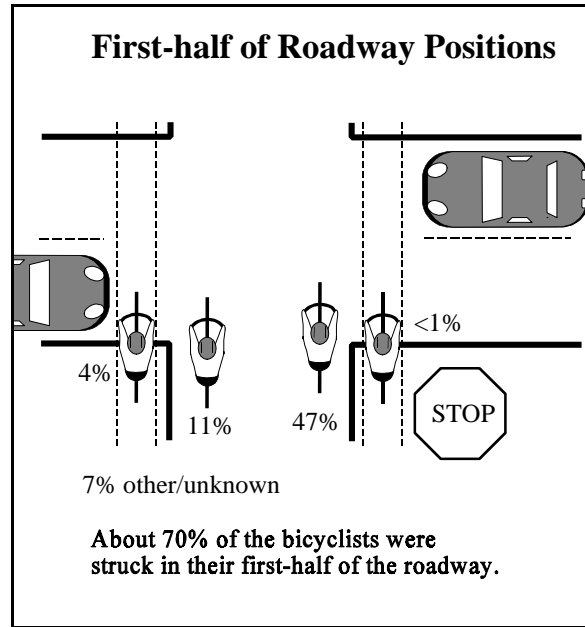

Figure 85. First-half positions in “Ride Out At Stop Sign.”

Second-half of Roadway Positions

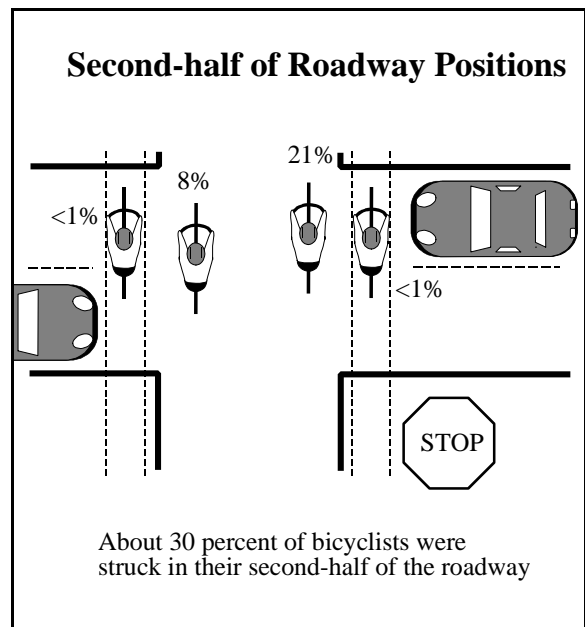
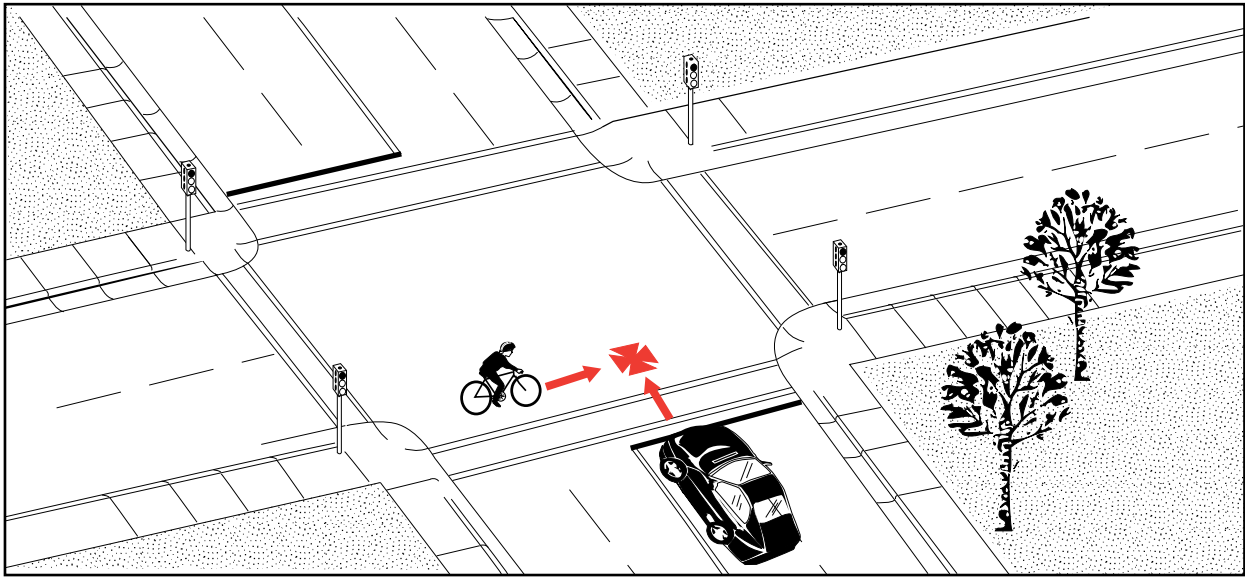

Figure 86. Second-half positions in “Ride Out At Stop Sign.”

Trapped

Frequency: 15 cases; 0.5% of all crashes
Severity: 7% resulted in serious or fatal injuries



Description: The bicyclist did not clear the intersection before the traffic signal turned green for cross traffic, and the motorist's view of the bicyclist was **not** obstructed.

Summary: In comparison to all crashes, this crash was more likely to involve youth (age 10 to 14), teen (age 15 to 19), and elder adult (age 65+) bicyclists. Child (age 0 to 9) and middle adult (age 45 to 64) bicyclists were not represented.

Multilane roads (4, 5, 6+ lanes) accounted for more than 4/5 of these events and the speed limit was 50 to 60 km/h for 70 percent. None took place on 40 km/h roads.

This crash had a lower incidence of serious injuries than the average. There were no fatalities.

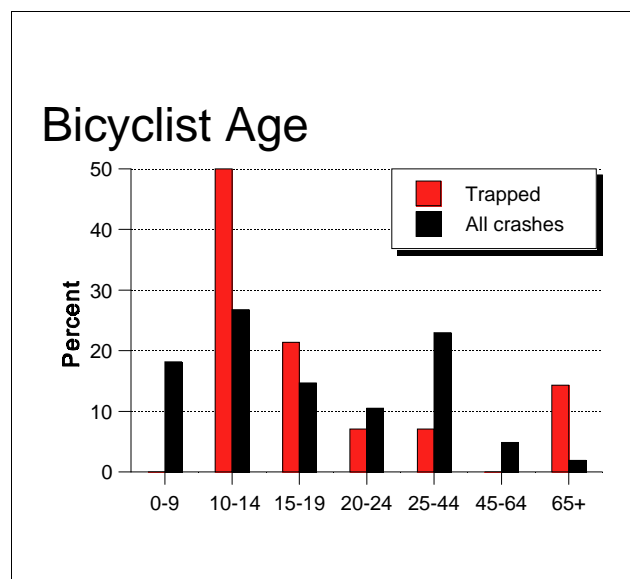
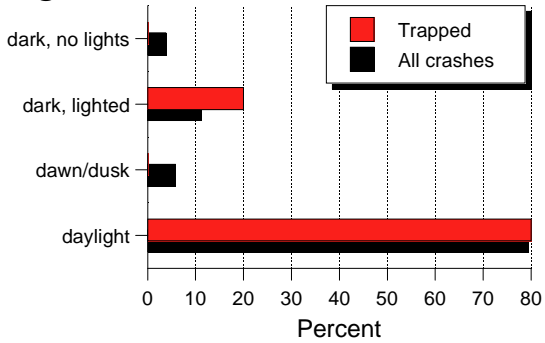

Figure 51. Bicyclist age in "Trapped."

Trapped

Light Condition



Number of Lanes

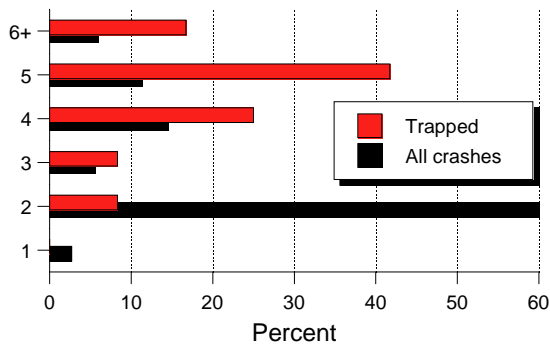

Speed Limit (km/h)

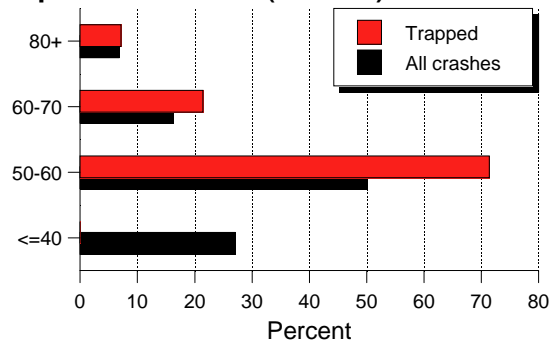

Figure 52. Light condition, number of lanes, and speed limit in “Trapped.”

Development Character

- ▶ Urban 60%
- ▶ Rural 40%

Positions

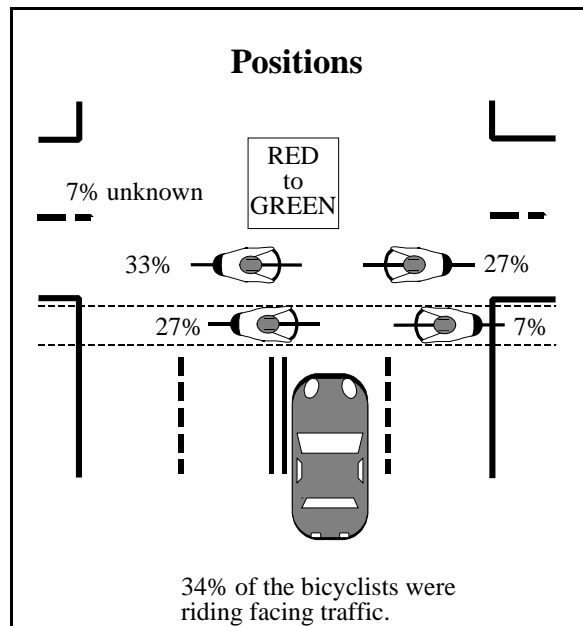
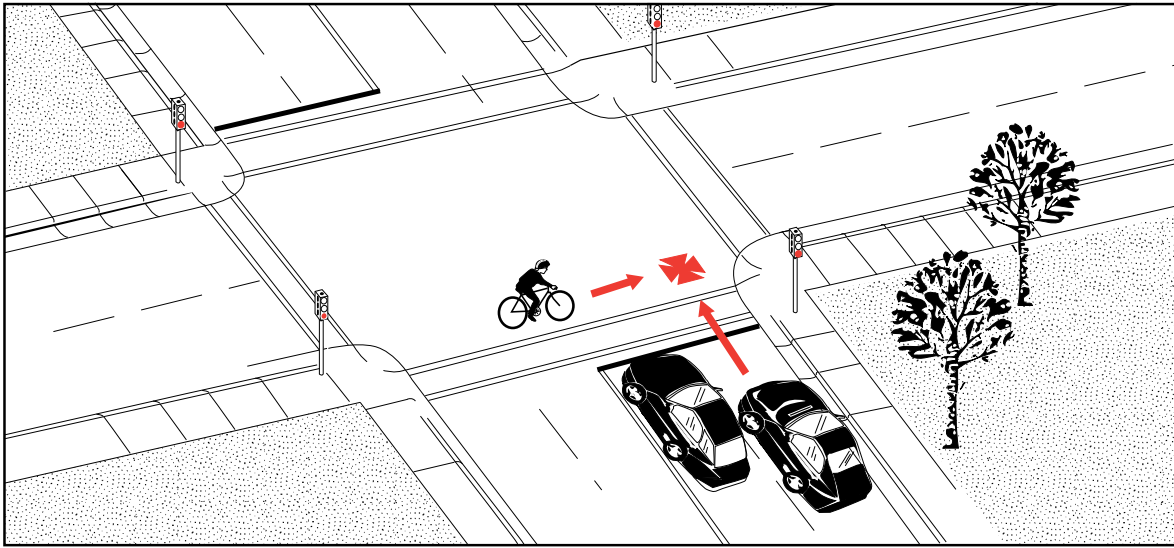

Figure 53. Positions in “Trapped.”

Multiple Threat

Frequency: 27 cases; 0.9% of all crashes
Severity: 15% resulted in serious or fatal injuries



Description: The bicyclist did not clear the intersection before the light turned green for cross traffic, **and** the motorist's view of the bicyclist was obstructed by standing traffic.

Summary: In comparison to all crashes, this crash was more likely to involve youth (age 10 to 14), teen (age 15 to 19), and young adult (age 20 to 24) bicyclists. Middle (age 45 to 64) and elder adults (age 65+) were not represented.

All of these crashes took place on multilane roads (4, 5, 6+ lanes), and high-speed (60 to 70 km/h) and very high-speed (80+ km/h) roads accounted for about 55 percent. None took place on roads of 40 km/h or less.

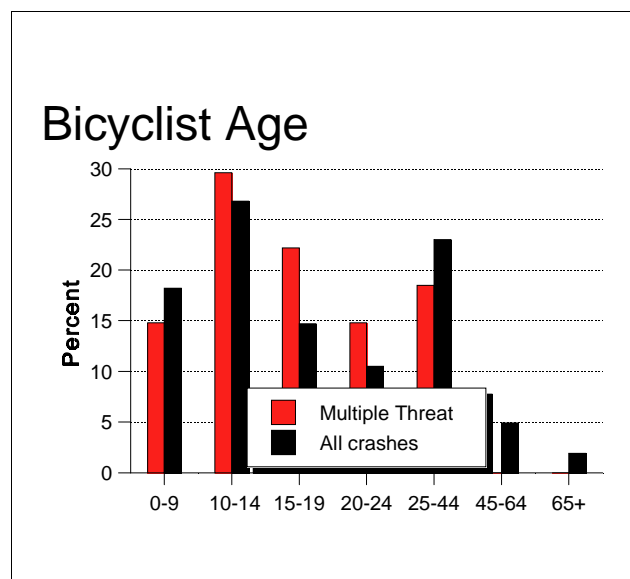
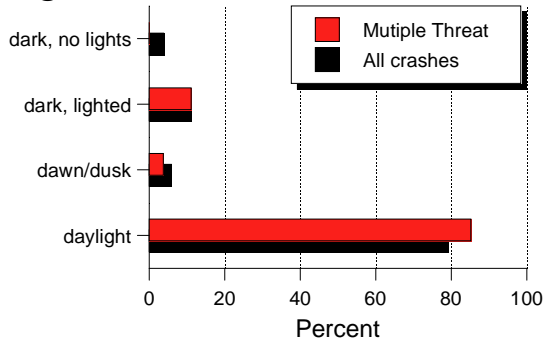

Figure 54. Bicyclist age in “Multiple Threat.”

Mutiple Threat

Light Condition



Number of Lanes

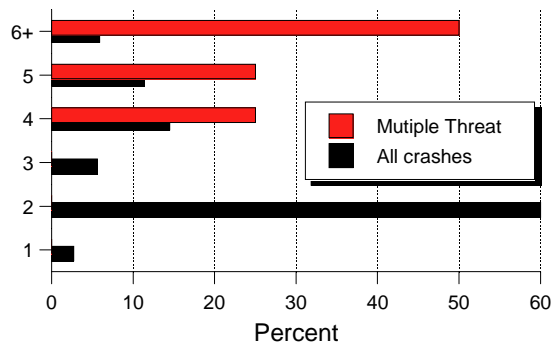

Speed Limit (km/h)

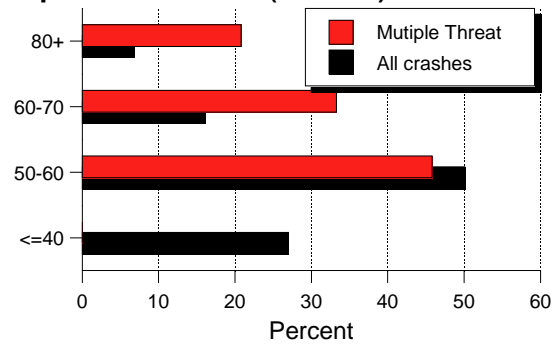

Figure 55. Light condition, number of lanes, and speed limit in “Multiple Threat.”

Development Character

- ▶ Urban 52%
- ▶ Rural 48%

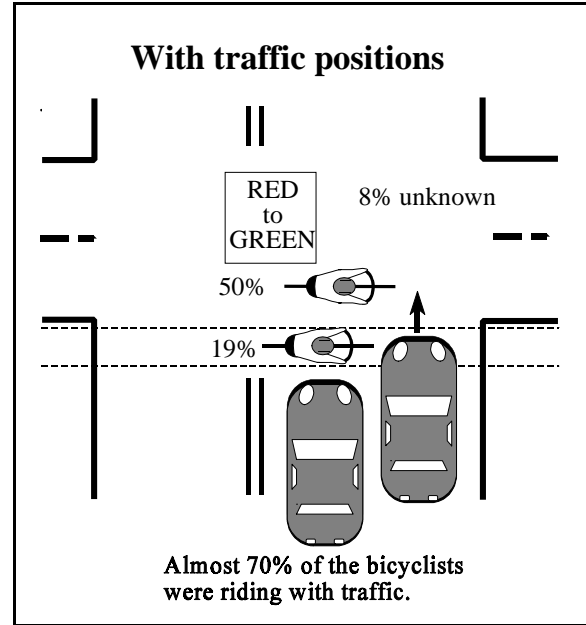

Figure 56. With traffic positions in “Multiple Threat.”

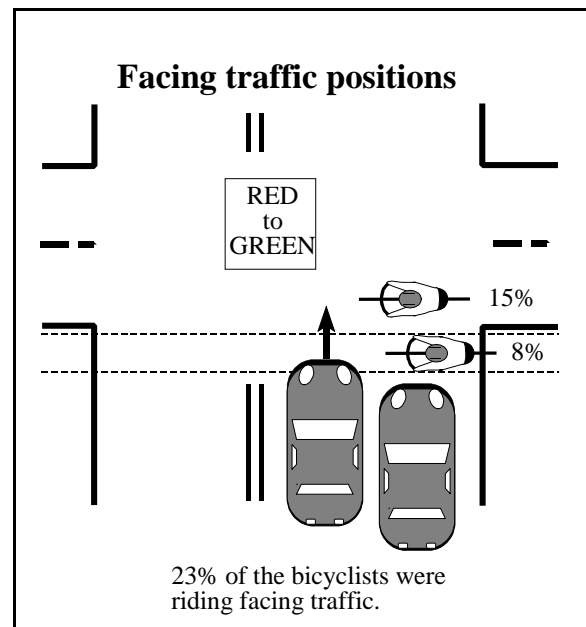
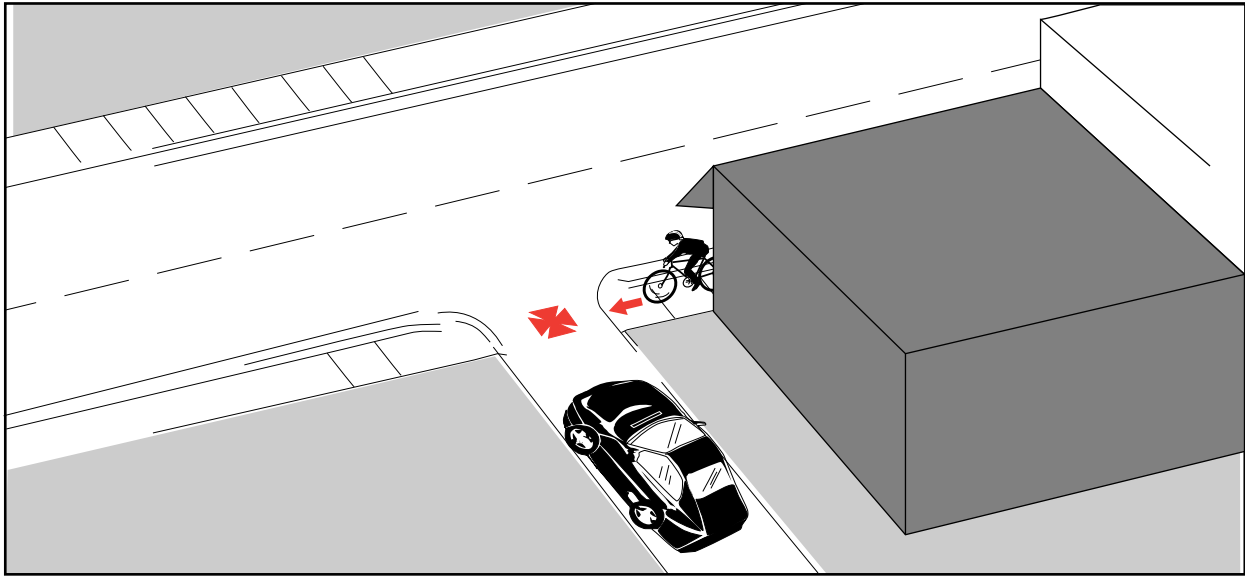

Figure 57. Facing traffic positions in “Multiple Threat.”

Drive Out At Midblock

Frequency: 207 cases; 6.9% of all crashes
Severity: 7% resulted in serious and fatal injuries



Description: The motorist was entering the roadway from a driveway or alley.

Summary: In comparison to all crashes, this event was more likely to involve teen (age 15 to 19) and all adult (age 20+) bicyclists.

More than 55 percent occurred on multilane roads, and almost 30 percent took place on roads with a speed limit of 60 to 70 km/h.

More than 3/4 occurred at public driveways. Almost one in five bicyclists were on a sidewalk that was continuous over the driveway.

Slightly more than 2/3 of the bicyclists, including those on a sidewalk, were riding against traffic.

This crash tended to be less severe than the average.

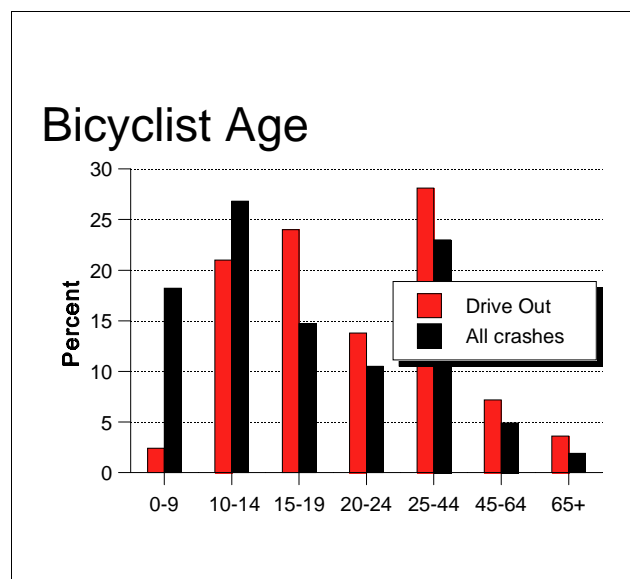
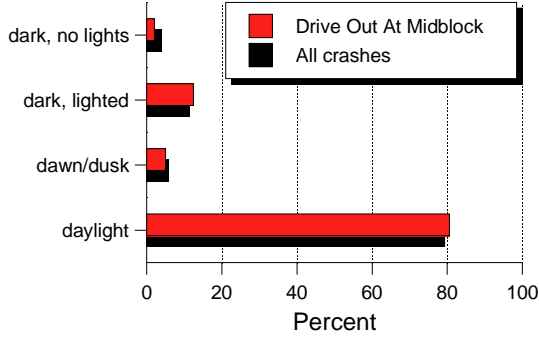

Figure 58. Bicyclist age in “Drive Out At Midblock.”

Drive Out At Midblock

Light Condition



Number of Lanes

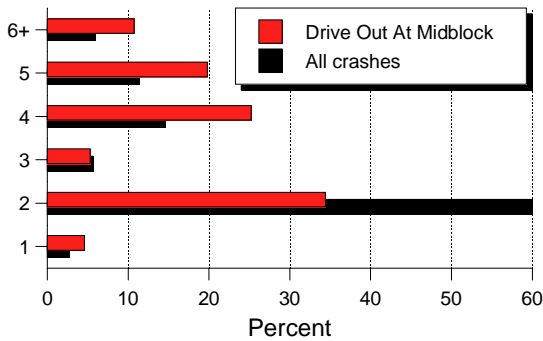

Speed Limit (km/h)

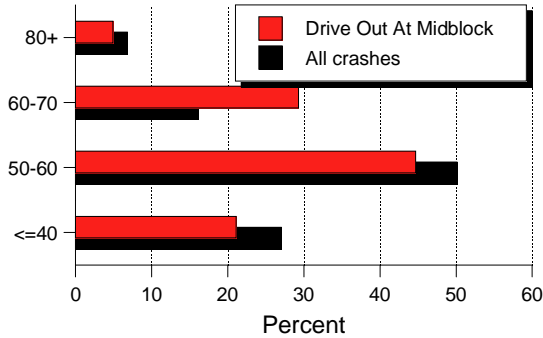

Figure 59. Light condition, number of lanes, and speed limit in “Drive Out At Midblock.”

Development Character

- ▶ Urban 75%
- ▶ Rural 25%

Road Feature

- ▶ Public Driveway . . . 77%
- ▶ Private Driveway . . 17%
- ▶ Alley 5%

Positions

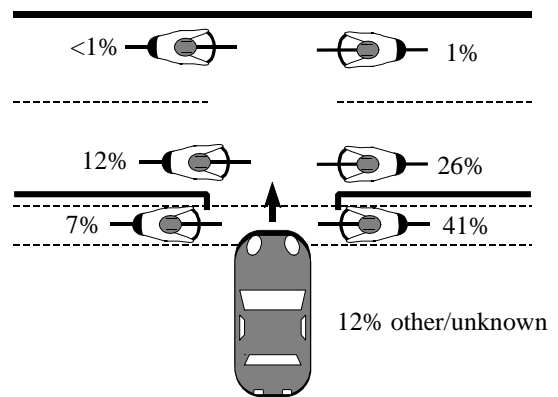

Two thirds of the bicyclists were riding facing traffic. Almost 1/2 were in the “off road” position.

Figure 60. Positions in “Drive Out At Midblock.”

Drive Out At Stop Sign

Frequency: 277 cases; 9.3% of all crashes

Severity: 10% resulted in serious or fatal injuries

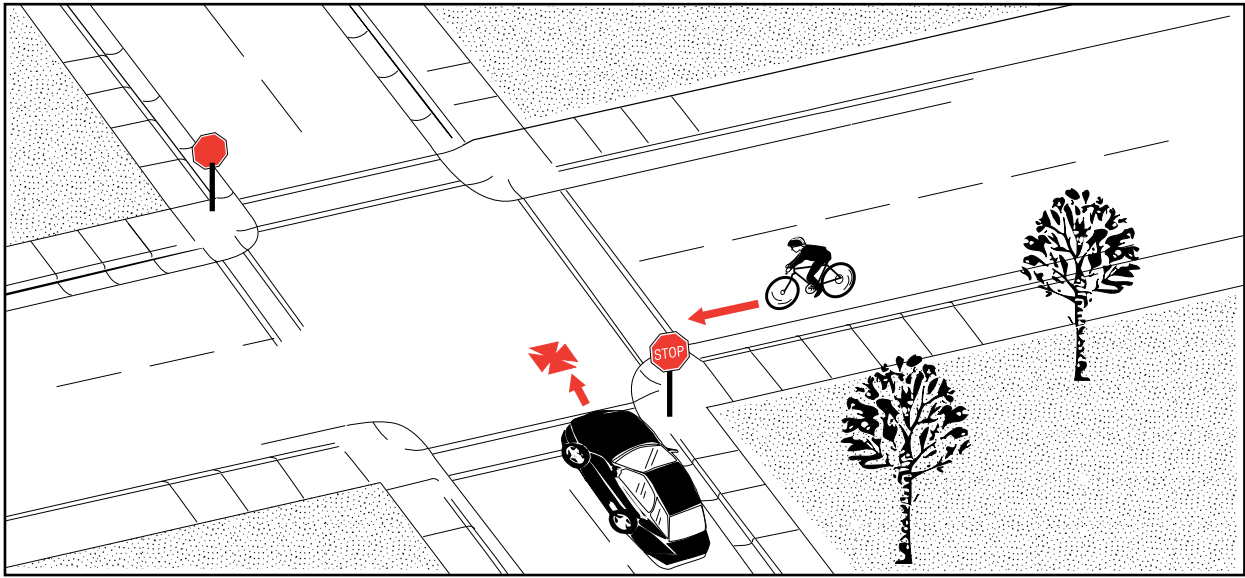

Description: The crash occurred at an intersection at which the motorist was facing a stop sign.

Summary: In comparison to all crashes, this crash was more likely to involve teen (age 15 to 19) and adult (age 25 to 44) bicyclists. More than 3/4 of these events occurred in urban areas.

The light condition, number of lanes, and speed limit parameters closely followed the results for all crashes combined.

About 60 percent of the bicyclists were riding facing traffic, whether “in road” or “off road.”

This type of crash tended to be less severe than the average.

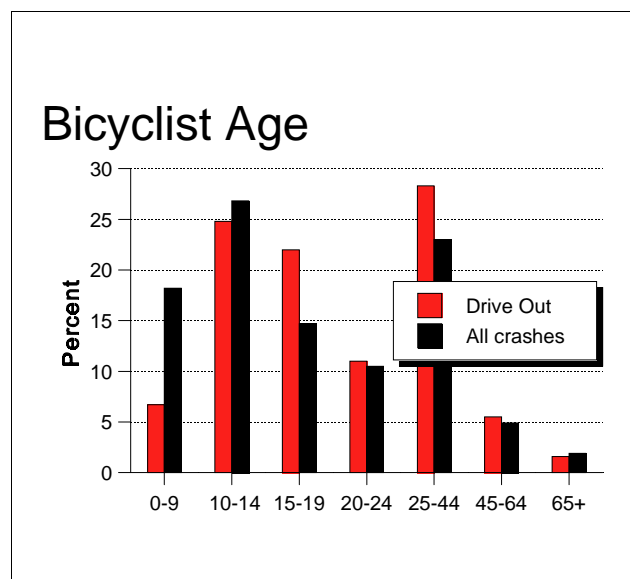
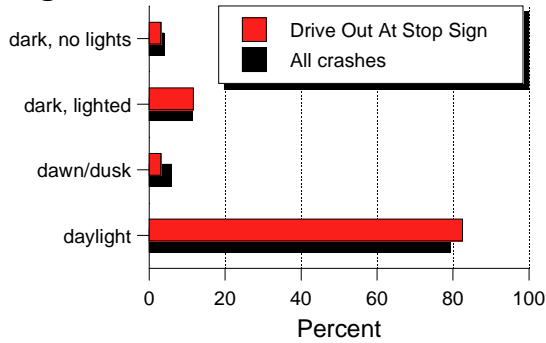

Figure 64. Bicyclist age in “Drive Out At Stop Sign.”

Drive Out At Stop Sign

Light Condition



Number of Lanes

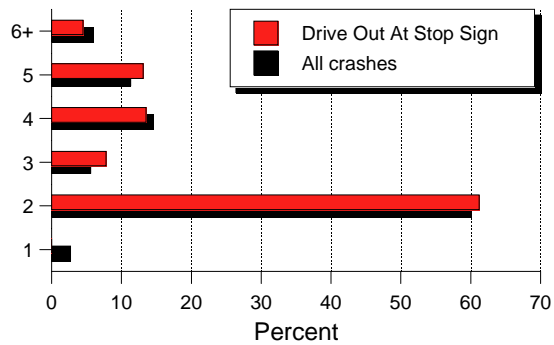

Speed Limit (km/h)

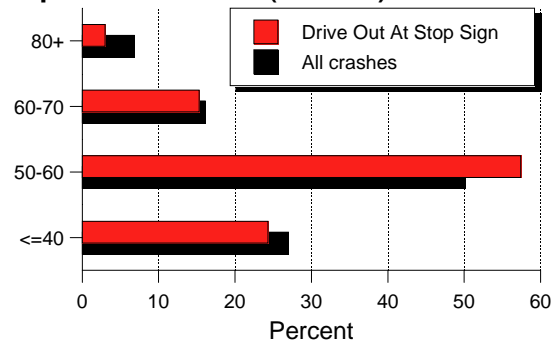

Figure 65. Light condition, number of lanes, and speed limit in “Drive Out At Stop Sign.”

Development Character

- ▶ Urban 78%
- ▶ Rural 22%

Facing Traffic Positions

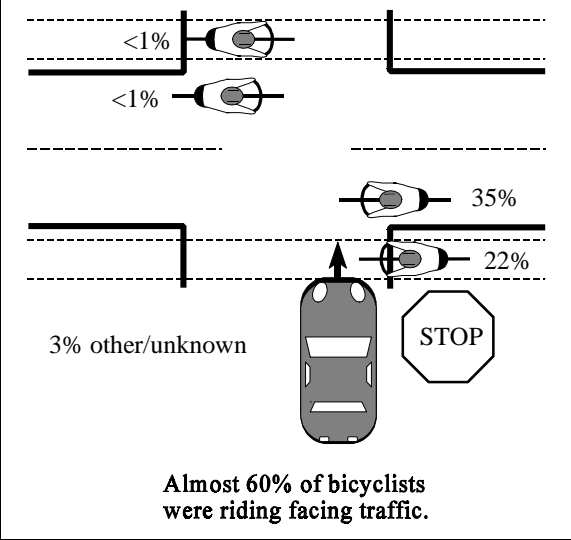

Figure 66. Facing traffic positions in “Drive Out At Stop Sign.”

With Traffic Positions

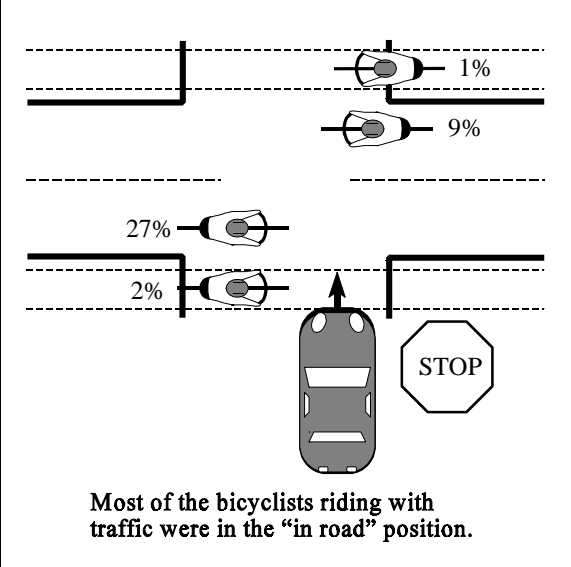

Figure 67. With traffic positions in “Drive Out At Stop Sign.”

Unknown

Frequency: 50 cases; 1.7% of all crashes
Severity: 11% resulted in serious or fatal injuries

No drawing

Description: Insufficient information was available to specify a crash type. It was determined that:

- ▶ 38 percent were on crossing paths.
- ▶ 30 percent were on parallel paths.
- ▶ in 32 percent the pre-crash path was unknown.

Summary: The bicyclist age distribution for this crash generally corresponded with that of all crashes combined. About 30 percent occurred during darkness, and 75 percent took place on two-lane roads.

Forty six percent were hit & run.

Some type of road or environmental condition such as weather, vision obstruction, glare, etc. was noted in 44 percent of these crashes.

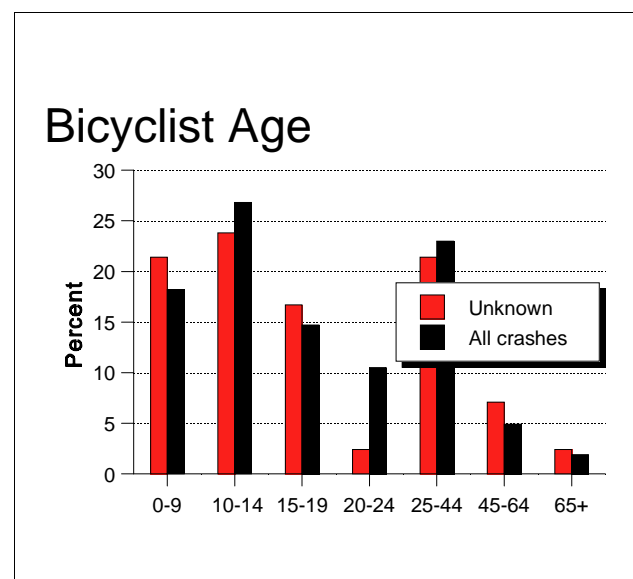
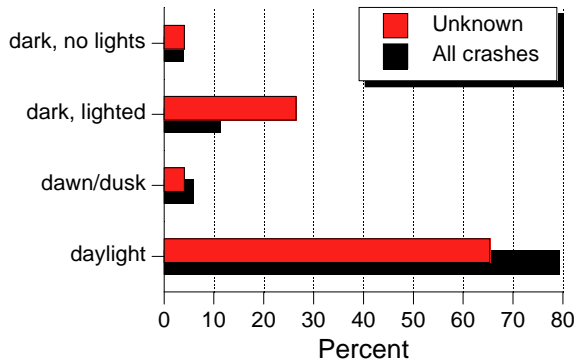
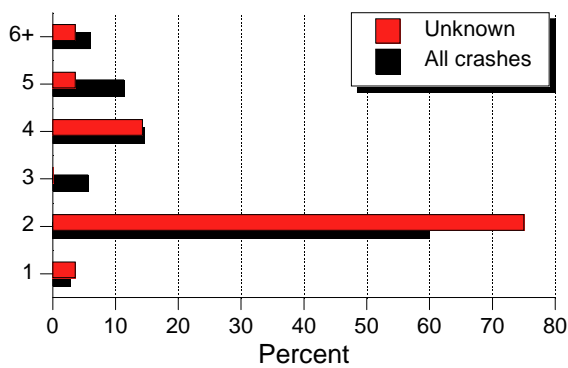

Figure 114. Bicyclist age in “Unknown.”

Light Condition



Number of Lanes



Speed Limit (km/h)

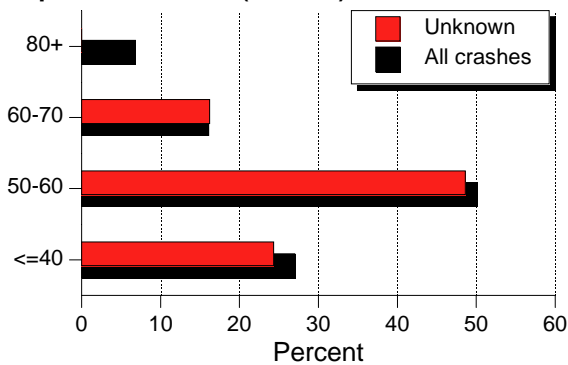

Development Character

- ▶ Urban 71%
- ▶ Rural 29%

Traffic Control

- ▶ None 56%
- ▶ Stop Sign 20%
- ▶ Traffic Signal 12%
- ▶ Other 12%

Road Feature

- ▶ Intersection 48%
- ▶ No special feature .. 36%
- ▶ Driveway/Alley 4%
- ▶ Other 12%

Figure 115. Light condition, number of lanes, and speed limit in “Unknown.”

Right On Red

Frequency: 108 cases; 3.6% of all crashes
Severity: 6% resulted in serious or fatal injuries

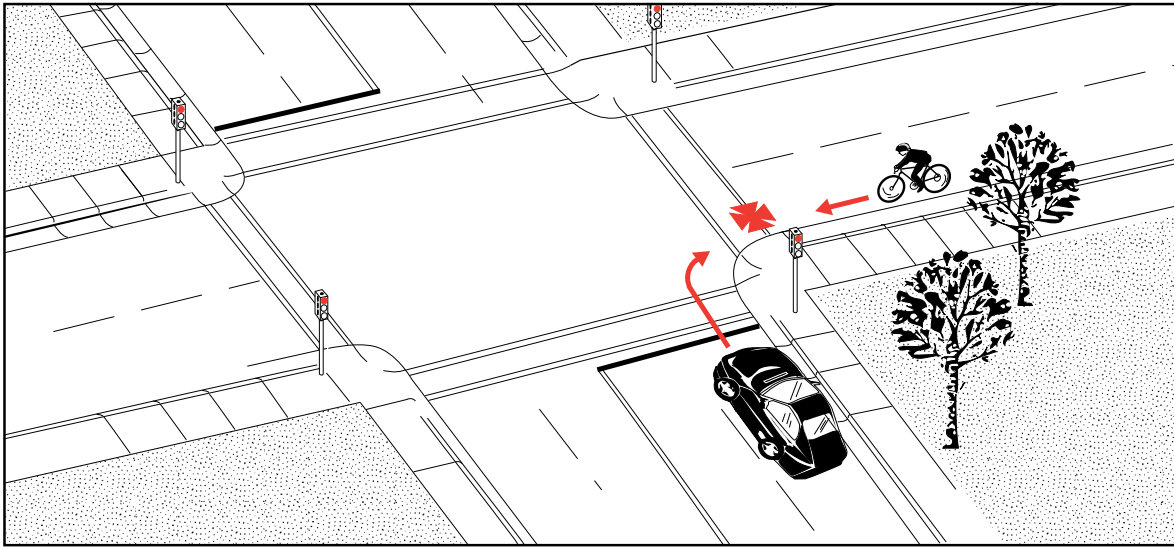

Description: At an intersection controlled by a signal, the motorist struck the bicyclist while making a right turn on red.

Summary: In comparison to all crashes, this crash was likely **not** to involve child (age 0 to 9) bicyclists.

More than 1/2 occurred at larger multilane intersections (5 and 6+ lanes). Almost 85 percent took place on roads with a speed limit between 50 to 70 km/h.

Eighty percent of bicyclists were riding facing traffic whether “in road” or “off road.”

Bicyclists were riding in a **marked** crosswalk in 45 percent. A marked crosswalk was involved in only 7 percent of all crashes combined.

This crash had a far lower incidence of serious injuries than the average. There were no

fatalities.

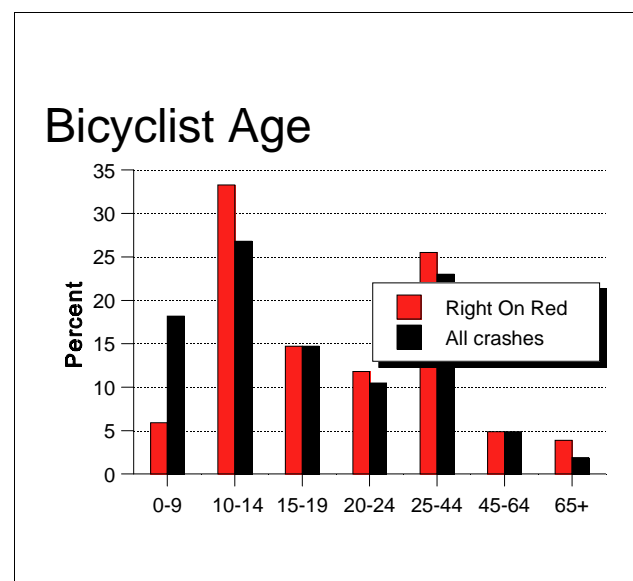
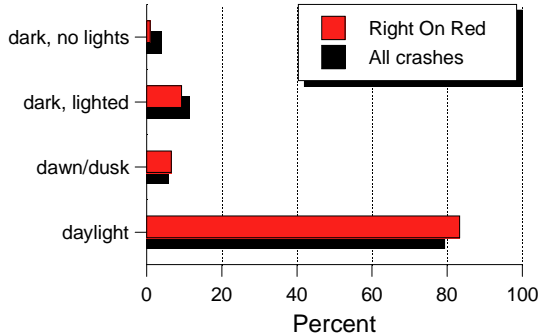

Figure 68. Bicyclist age in “Right On Red.”

Right On Red

Light Condition



Number of Lanes

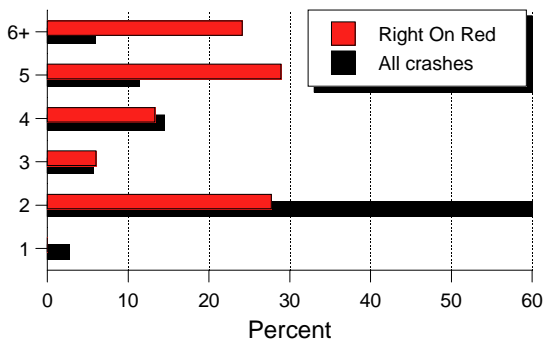

Speed Limit

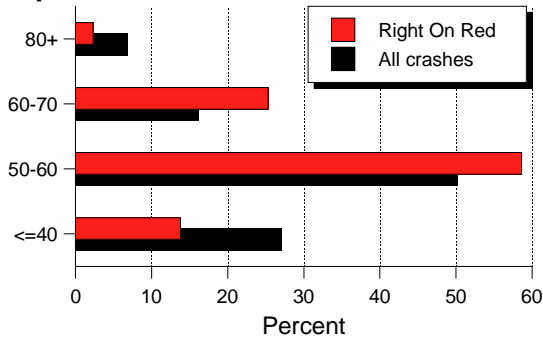
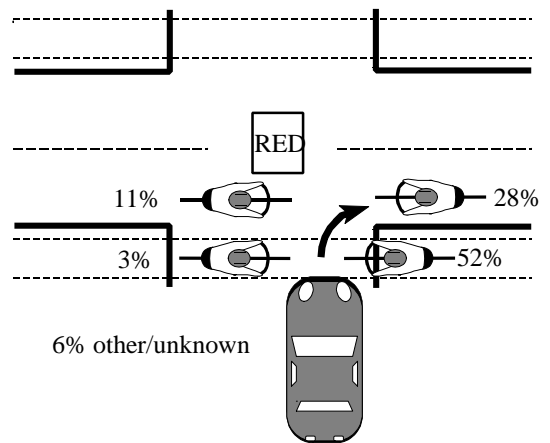

Figure 69. Light condition, number of lanes, and speed limit in “Right On Red.”

Development Character

- ▶ Urban 72%
- ▶ Rural 28%

Positions



4 out of 5 bicyclists were riding facing traffic.

Figure 70. Positions in “Right On Red.”

Backing

Frequency: 47 cases; 1.6% of all crashes
Severity: 2% resulted in serious or fatal injuries

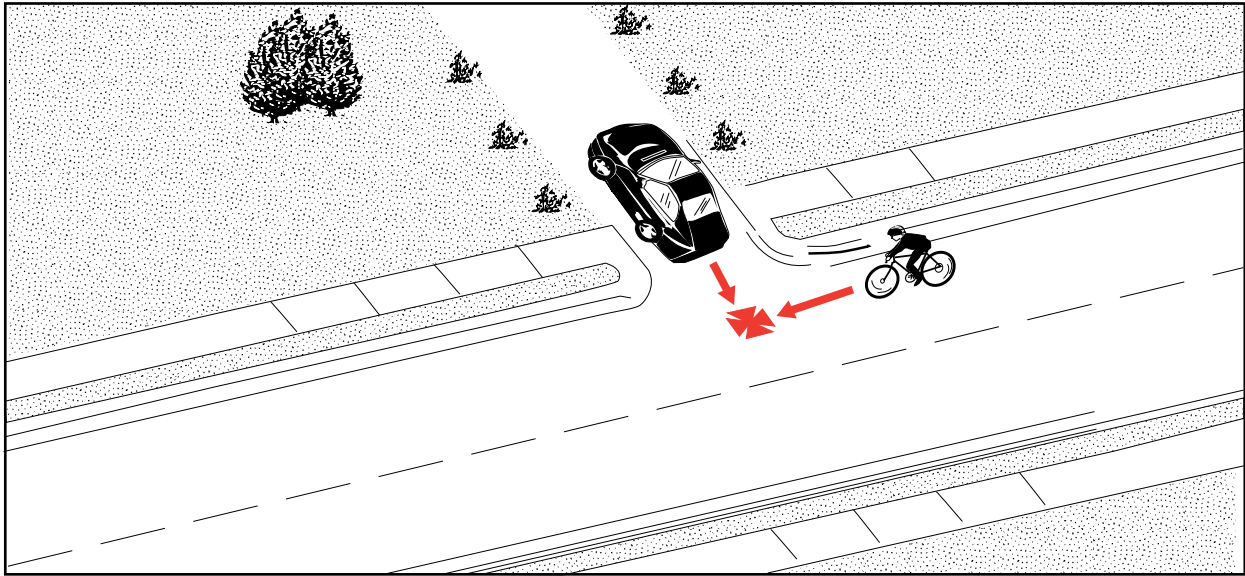

Description: The crash involved a motor vehicle which was backing. Note: Crash type “Play Vehicle” had an additional 7 backing incidents, which would bring the total for “Backing” to 54, or 1.8 percent of all crashes.

Summary: In comparison to all crashes, this crash was more likely to involve child (age 0 to 9) and middle adult (age 45 to 64) bicyclists.

Sixty-two percent occurred on the roadway. Of those, all happened on one- or two-lane roads. More than 40 percent had a speed limit of 40 km/h or less.

Of the 38 percent non-roadway, 19 percent took place in a parking lot, and in 19 percent the bicyclist and motorist were both in a driveway or alley.

This crash had a far lower incidence of serious injuries than the average. There were no

fatalities.

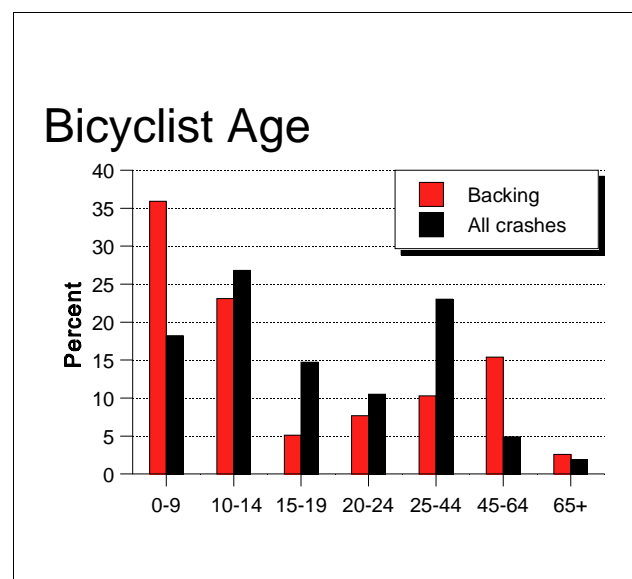
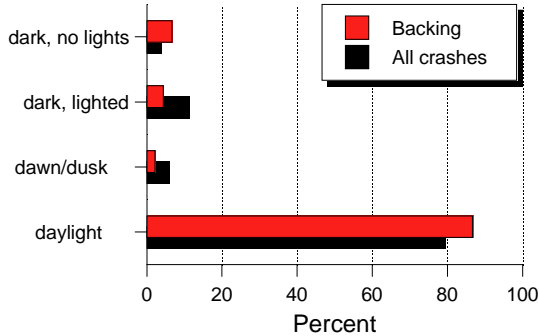

Figure 108. Bicyclist age in “Backing.”

Backing

Light Condition



Number of Lanes

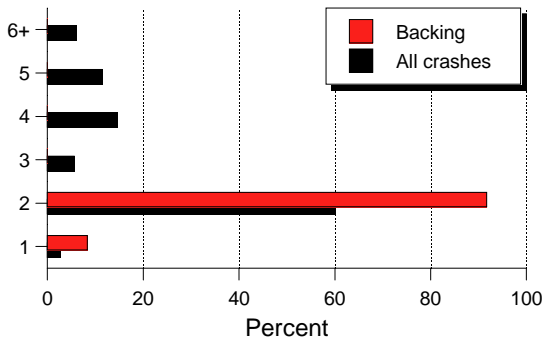

Speed Limit

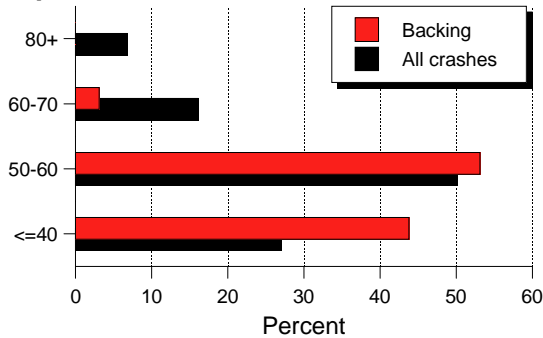

Figure 109. Light condition, number of lanes, and speed limit in “Backing.”

Development Character

- ▶ Urban 71%
- ▶ Rural 29%

Location

- ▶ Roadway 62%
- ▶ Non-roadway 38%

Road Feature

- ▶ Driveway/Alley . . . 52%
- ▶ No special feature . . 45%
- ▶ Other 4%

Roadway Positions

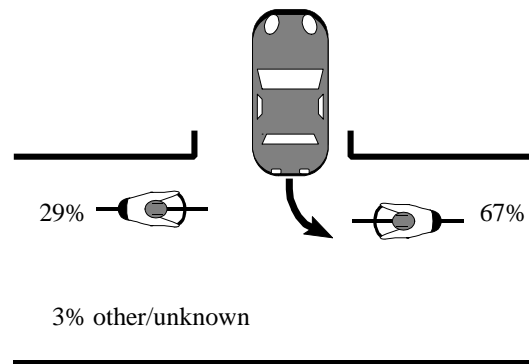

Of the bicyclists who were in the roadway, almost 1/3 were riding facing traffic.

Figure 110. Roadway positions in “Backing.”

Drive Through

Frequency: 45 cases; 1.5% of all crashes
Severity: 11% resulted in serious or fatal injuries

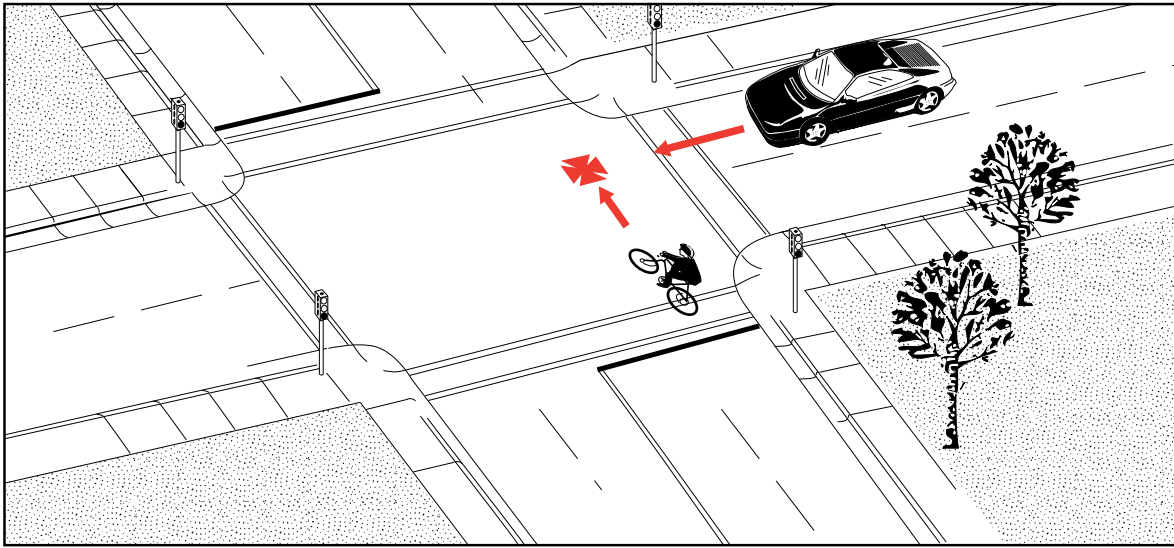

Description: At a controlled intersection, the motorist ran a sign or signal.

Summary: In comparison to all crashes, this crash was more likely to involve teen (age 15 to 19) and young adult (age 20 to 24) bicyclists, take place on multilane roads (4, 5, 6+ lanes), and occur during conditions of darkness with street lights.

More than 70 percent occurred on roads with a 50 to 60 km/h speed limit.

Thirty four percent were hit & run.

This type of crash tended to be less severe than the average.

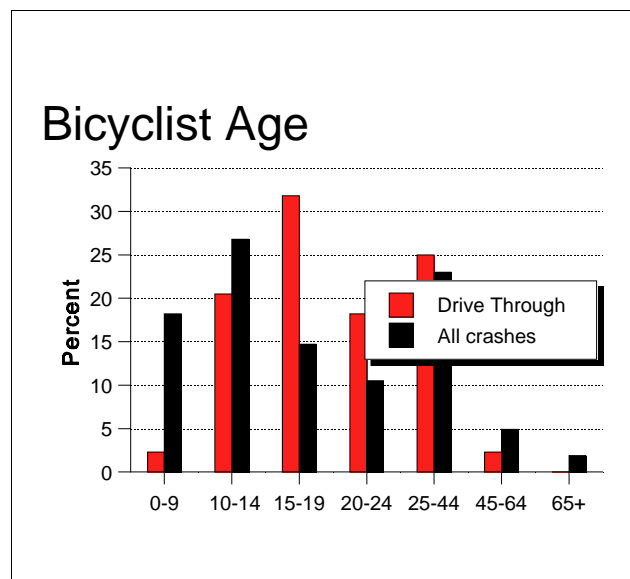
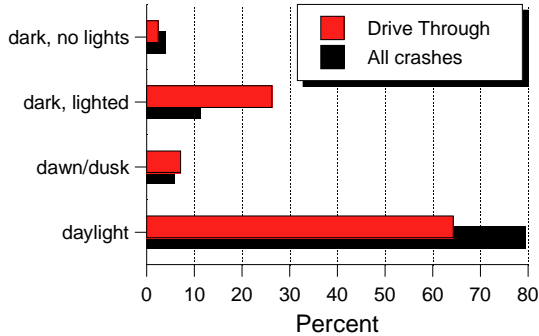

Figure 61. Bicyclist age in “Drive Through.”

Drive Through

Light Condition



Number of Lanes

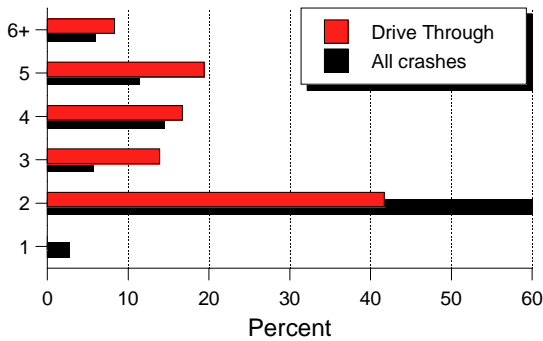

Speed Limit (km/h)

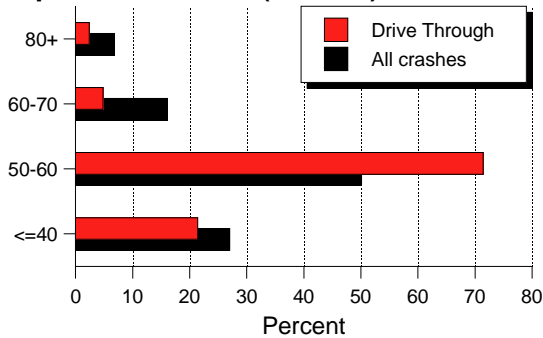

Figure 62. Light condition, number of lanes, and speed limit in “Drive Through.”

Development Character

- ▶ Urban 70%
- ▶ Rural 30%

Traffic Control

- ▶ Traffic Signal 49%
- ▶ Stop Sign 47%
- ▶ Other 4%

Positions

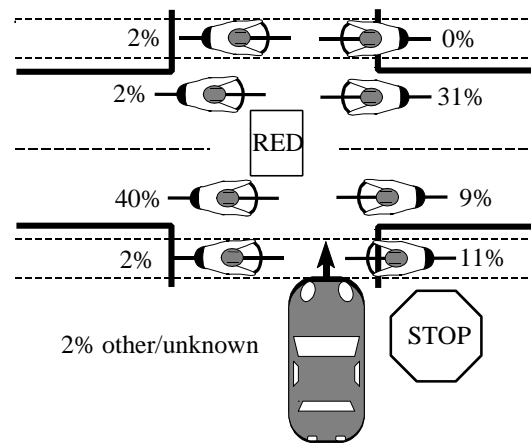

About 3 out of 5 bicyclists were in the first half of the roadway relative to the motorist.

Figure 63. Positions in “Drive Through.”

Motorist Overtaking— Failed To Detect

Frequency: 39 cases; 1.3% of all crashes
Severity: 54% resulted in serious or fatal injuries

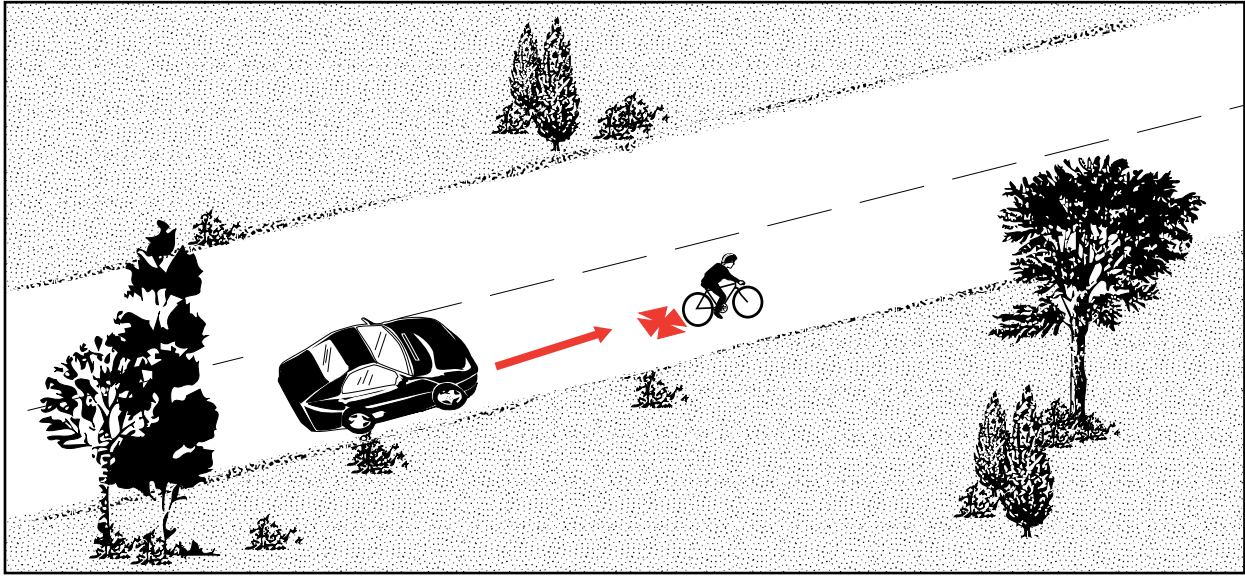

Description: The motorist was overtaking and failed to detect the bicyclist.

Summary: This crash involved almost exclusively adult bicyclists age 20 and above.

High-speed (60 to 70 km/h) and very high-speed (80+ km/h) roads were strongly represented. More than 60 percent of the crashes took place in rural areas.

About 60 percent occurred under low light conditions, with 4 out of 10 happening during darkness with no street lights. Drivers were blinded by the sun in 28 percent of the daylight and dawn/dusk events.

Seventeen percent of adult bicyclists age 25 and older and 11 percent of motorists had been drinking. Almost 1 out of 6 were hit & run.

More than half resulted in serious or fatal

injuries.

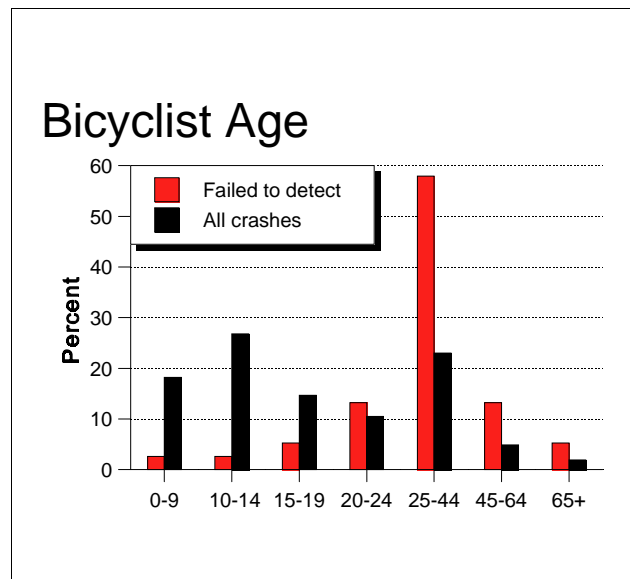
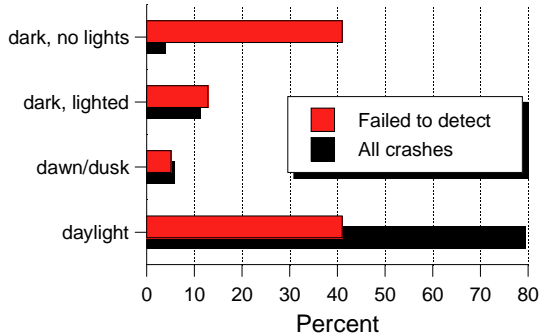

Figure 26. Bicyclist age in “Motorist Overtaking—Failed To Detect.”

Motorist Overtaking—Failed To Detect

Light Condition



Number of Lanes

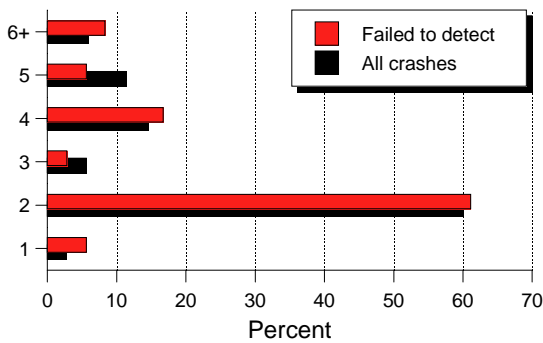

Speed Limit (km/h)

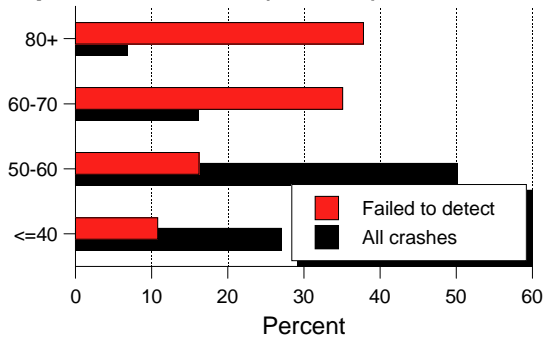

Figure 27. Light condition, number of lanes, and speed limit in “Motorist Overtaking—Failed To Detect.”

Development Character

- ▶ Urban 38%
- ▶ Rural 62%

Road Feature

- ▶ No special feature . . . 97%
- ▶ Intersection 3%

Positions

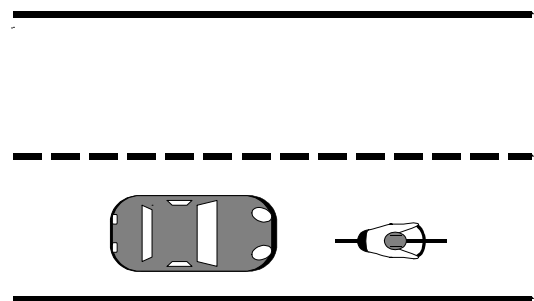

4 out of 10 bicyclists were undetected during daylight conditions.

Figure 28. Positions in “Motorist Overtaking—Failed To Detect.”

Motorist Lost Control

Frequency: 19 cases; 0.6% of all crashes
Severity: 37% resulted in serious or fatal injuries

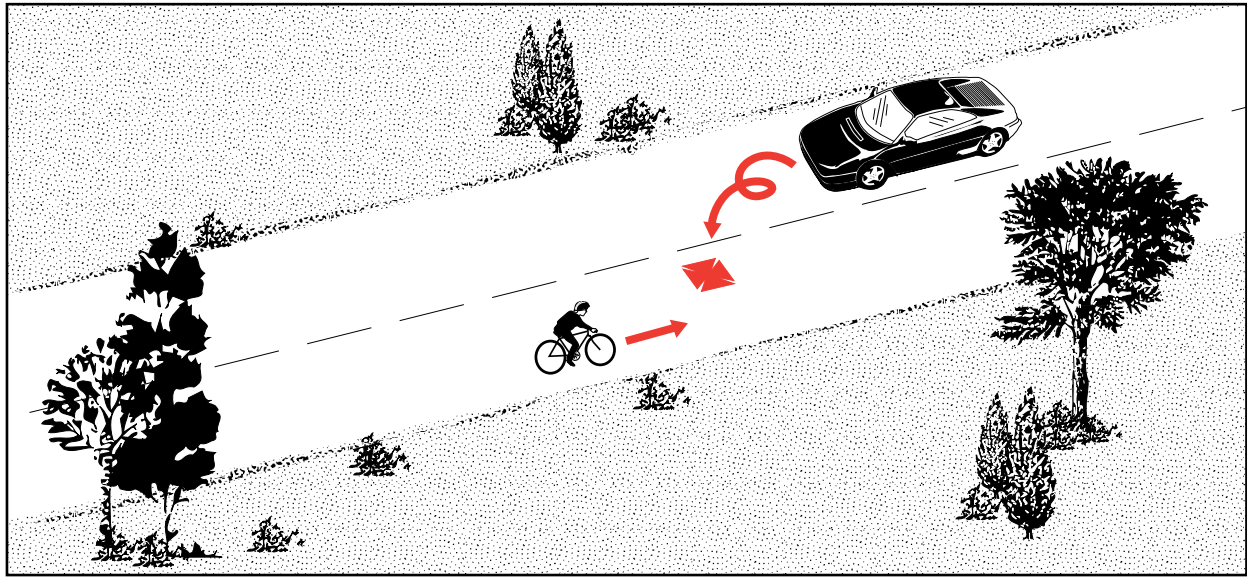

Description: The motorist lost control and inadvertently swerved into the path of the bicyclist.

Summary: In comparison to all crashes, this crash was much more likely to involve middle adult (age 45 to 64) bicyclists.

More than 40 percent occurred during low light conditions (dark with or without street lights, dawn/dusk). High-speed (60 to 70 km/h) and very high-speed (80+ km/h) roads accounted for 45 percent of the crashes.

Sixty-five percent of drivers had been drinking.

Almost one in five were hit & run.

This crash tended to be much more serious than the average.

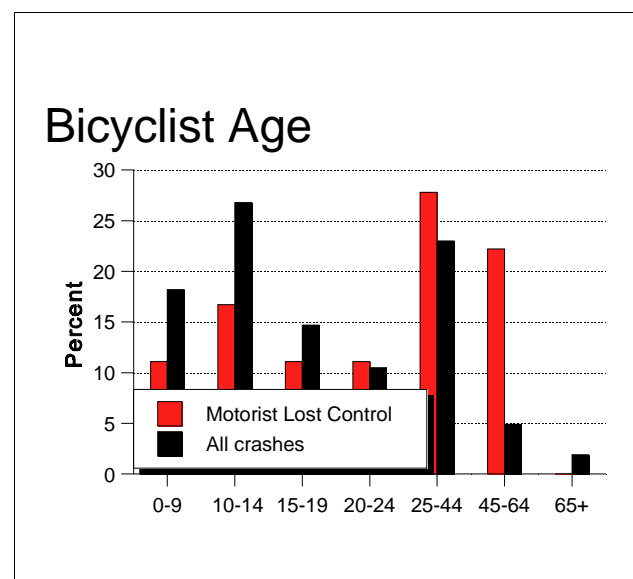
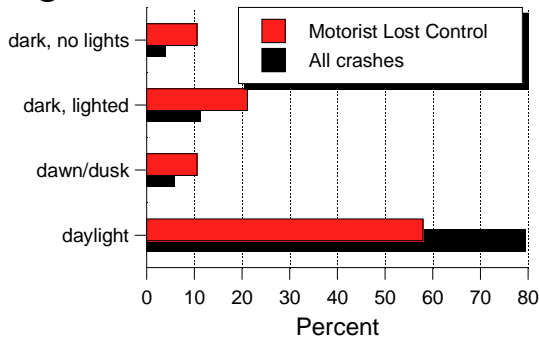

Figure 45. Bicyclist age in “Motorist Lost Control.”

Motorist Lost Control

Light Condition



Number of Lanes

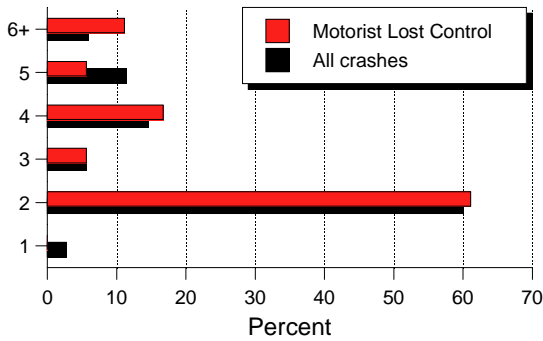

Speed Limit (km/h)

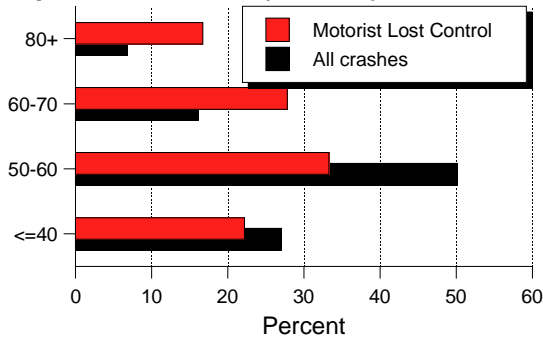

Figure 46. Light condition, number of lanes, and speed limit in “Motorist Lost Control.”

Development Character

- ▶ Urban 58%
- ▶ Rural 42%

Traffic Control

- ▶ None 84%
- ▶ Traffic Signal 0%
- ▶ Stop Sign 11%
- ▶ Other 5%

Road Feature

- ▶ No special feature .. 84%
- ▶ Intersection 11%
- ▶ Other 5%

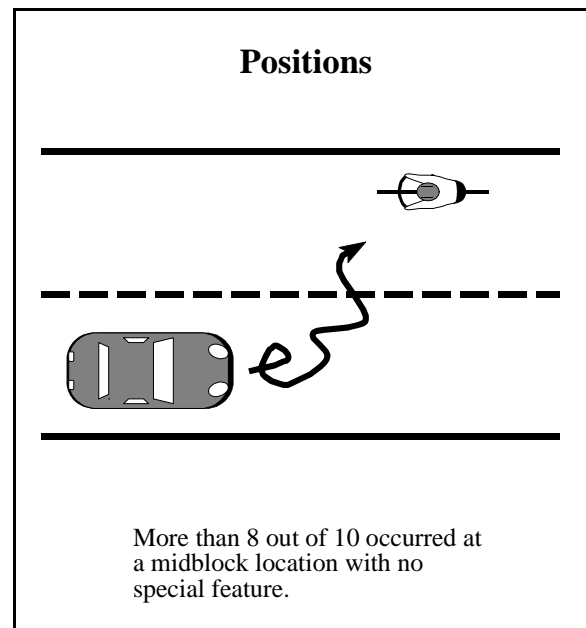
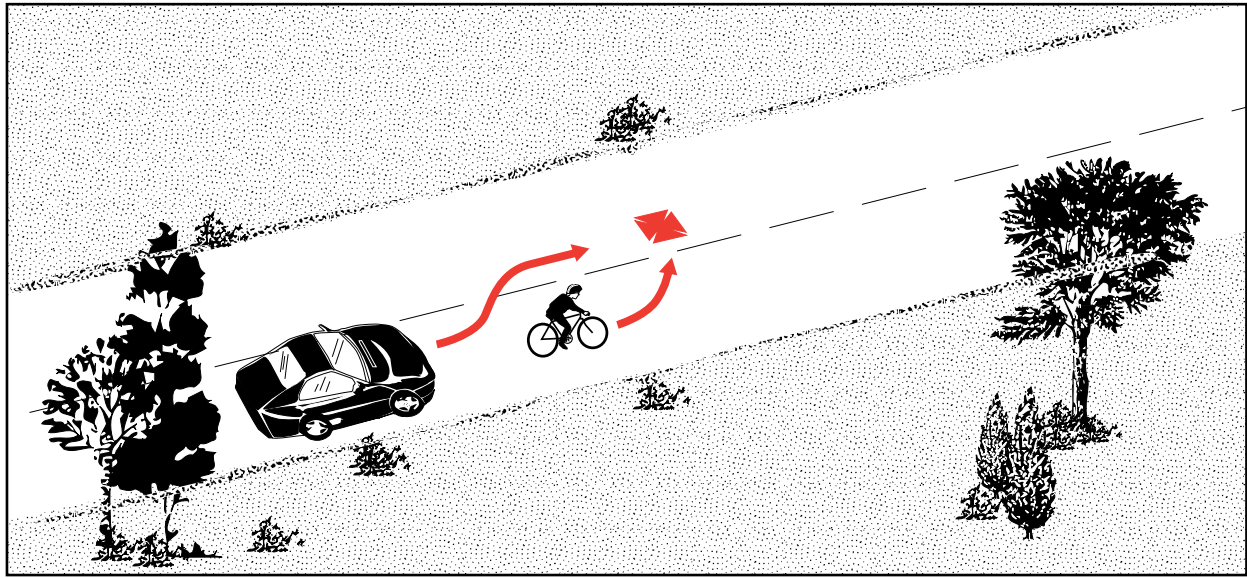

Figure 47. Positions in “Motorist Lost Control.”

Motorist Overtaking— Counteractive Evasive Actions

Frequency: 59 cases; 2.0% of all crashes
Severity: 22% resulted in serious or fatal injuries



Description: The motorist was overtaking the bicyclist and the evasive actions were counteractive. The bicyclist swerved left (or, very rarely, right).

Summary: In comparison to all crashes, this crash was more likely to involve youth (age 10 to 14) bicyclists.

Almost all occurred on 2-lane roads, and very high-speed (80+ km/h) roads were strongly represented, accounting for 35 percent of the crashes.

Almost 60 percent occurred in rural areas.

This crash was about average in severity. There were no fatalities.

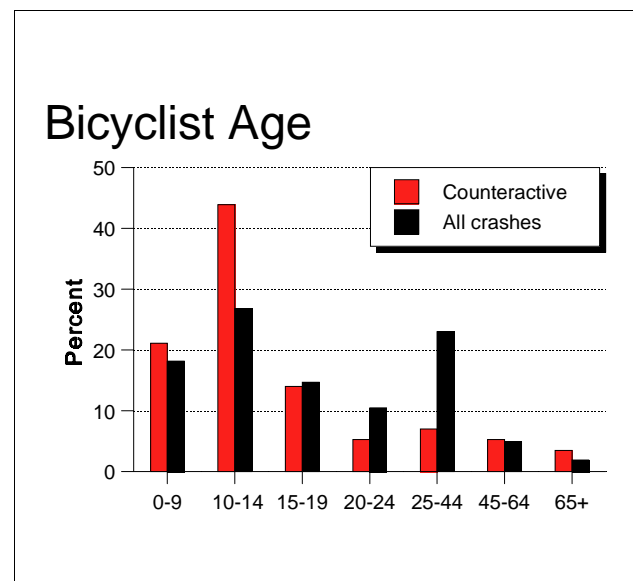
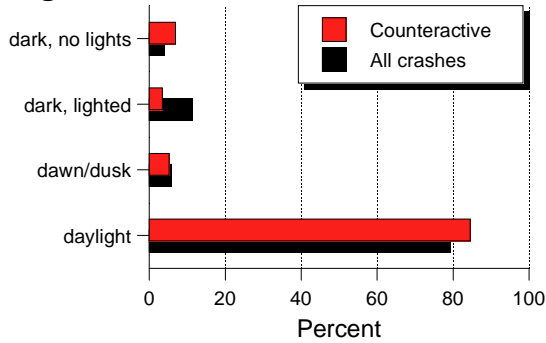

Figure 29. Bicyclist age in “Motorist Overtaking—Counteractive Evasive Actions.”

Motorist Overtaking—Counteractive Evasive Actions

Light Condition



Number of Lanes

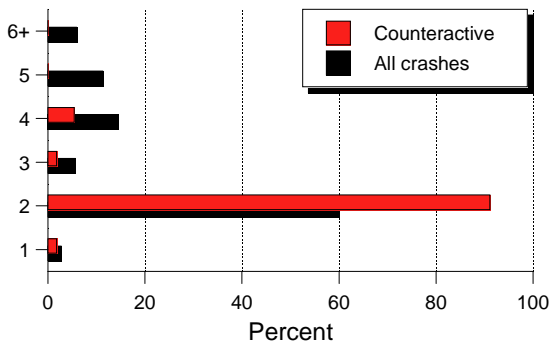

Speed Limit (km/h)

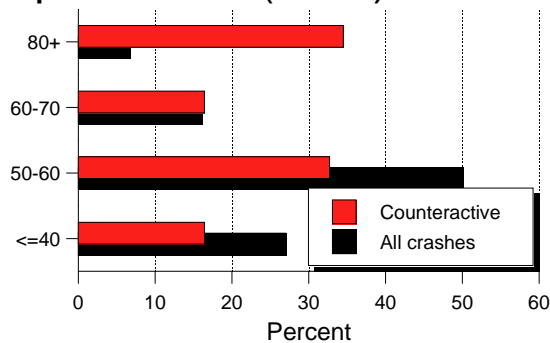

Figure 30. Light condition, number of lanes, and speed limit in “Motorist Overtaking—Counteractive Evasive Actions.”

Development Character

- ▶ Urban 43%
- ▶ Rural 57%

Road Feature

- ▶ No special feature . . . 93%
- ▶ Intersection 3%
- ▶ Other 3%

Positions

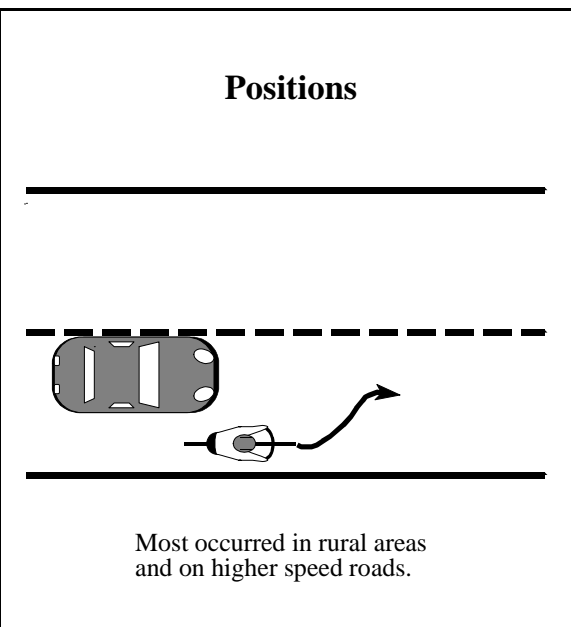
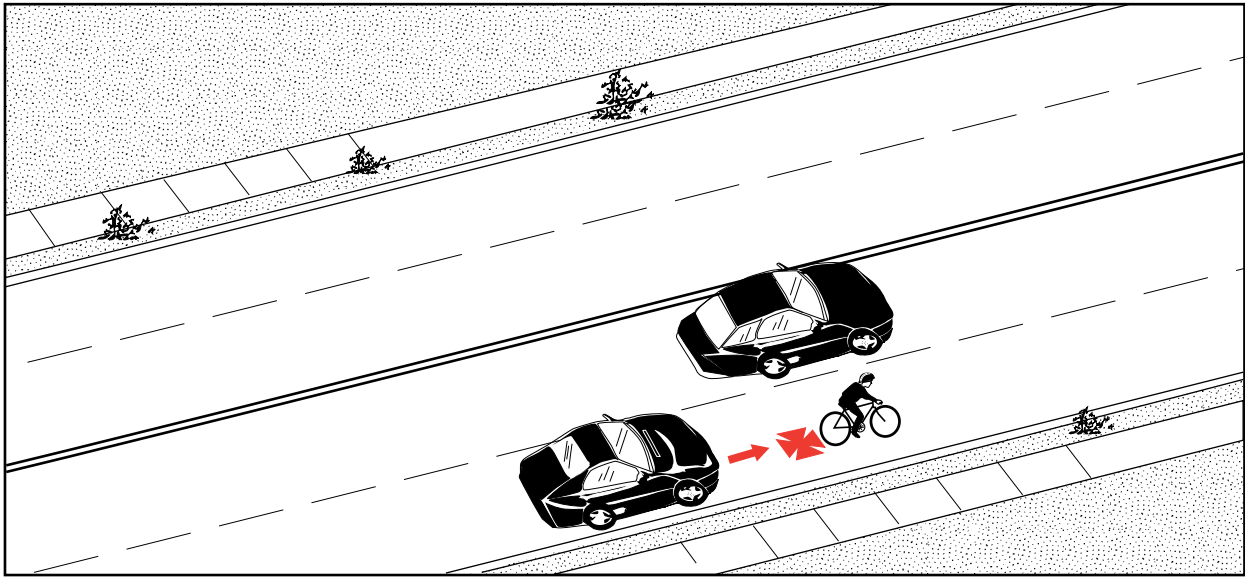

Figure 31. Positions in “Motorist Overtaking—Counteractive Evasive Actions.”

Motorist Overtaking— Misjudged Passing Space

Frequency: 37 cases; 1.2% of all crashes
Severity: 22% resulted in serious or fatal injuries



Description: The motorist was overtaking and misjudged the width or length required to pass the bicyclist.

Summary: In comparison to all crashes, this crash was more likely to involve adult (age 25 to 44), middle adult (age 45 to 64), and elder adult (age 65+) bicyclists. High-speed (60 to 70 km/h) and very high-speed (80+ km/h) roads were strongly represented.

While most of these crashes occurred at midblock locations, more than 20 percent occurred at or near an intersection.

Fourteen percent of the bicyclists were on the shoulder and 5 percent were in a bike lane. Sixteen percent were on a curve.

Seventeen percent of these events were motorist hit & run.

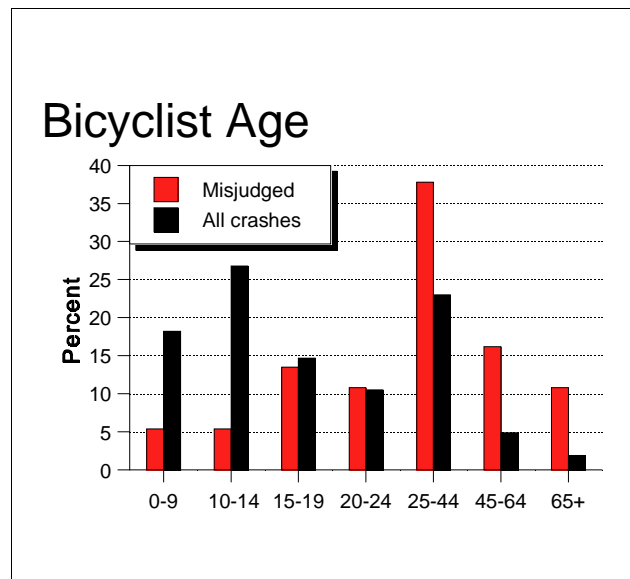
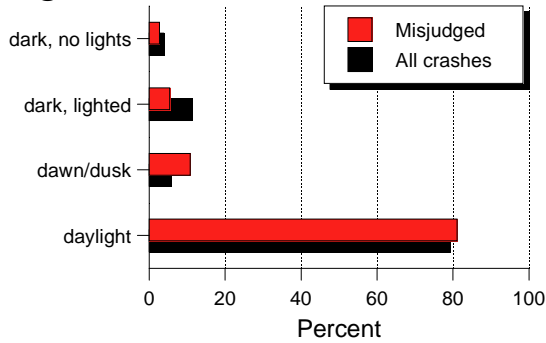
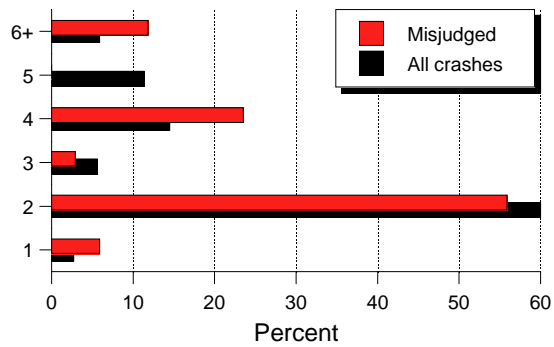

Figure 32. Bicyclist age in “Motorist Overtaking—Misjudged Passing Space.”

Light Condition



Number of Lanes



Speed Limit (km/h)

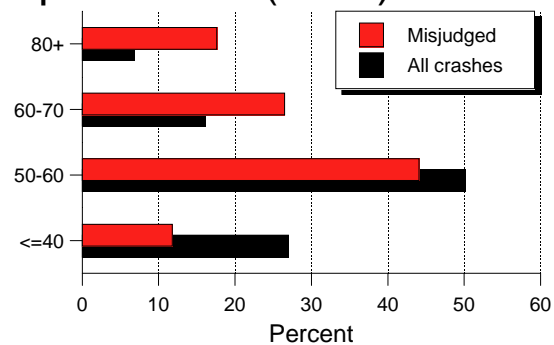

Figure 33. Light condition, number of lanes, and speed limit in “Motorist Overtaking—Misjudged Passing Space.”

Development Character

- ▶ Urban 57%
- ▶ Rural 43%

Road Feature

- ▶ No special feature . . . 70%
- ▶ Intersection 22%
- ▶ Driveway 3%
- ▶ Other 5%

Positions

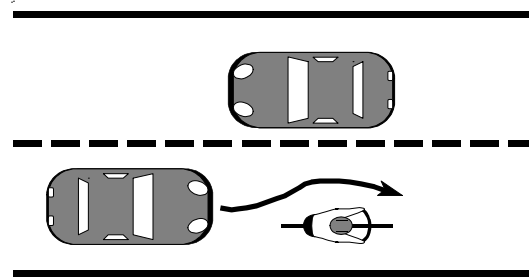

Almost 1 out of 5 bicyclists were on the shoulder or in a bike lane.

Figure 34. Positions in “Motorist Overtaking—Misjudged Passing Space.”

Motorist Overtaking— Bicyclist Path Obstructed

Frequency: 5 cases; 0.2% of all crashes
Severity: None resulted in serious or fatal injuries

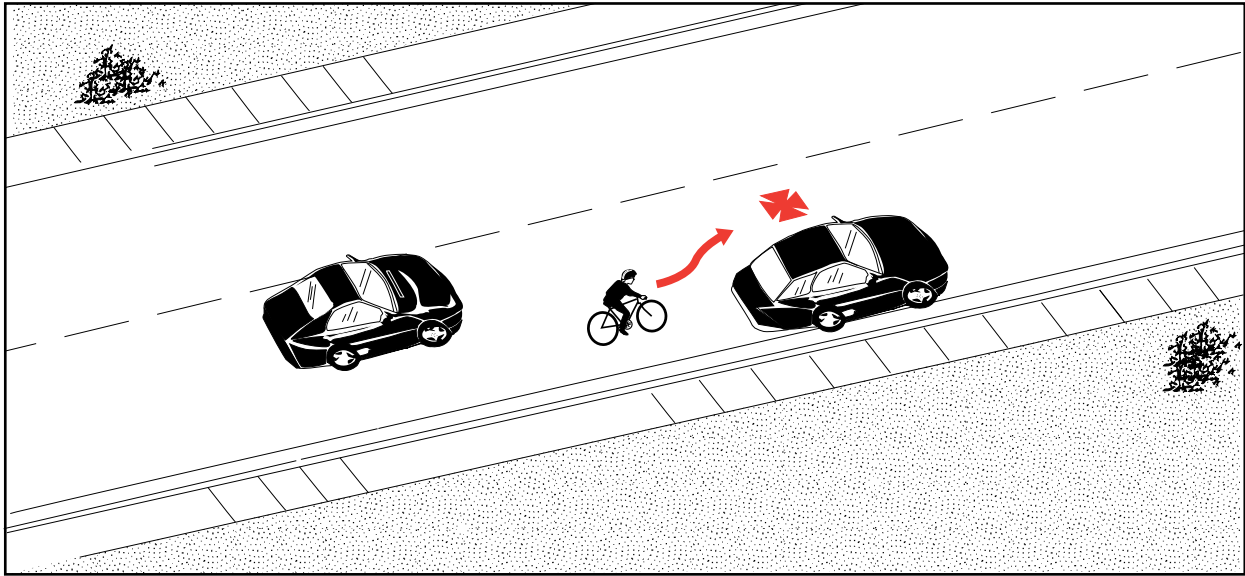

Description: The motorist was overtaking a bicyclist whose path was obstructed. The bicyclist struck the obstruction or overtaking motorist.

Summary: For the few ($n=5$) crashes of this type, four took place under daylight conditions, and one was on a road with a speed limit of 80+ km/h.

None of these crashes resulted in serious or fatal injuries.

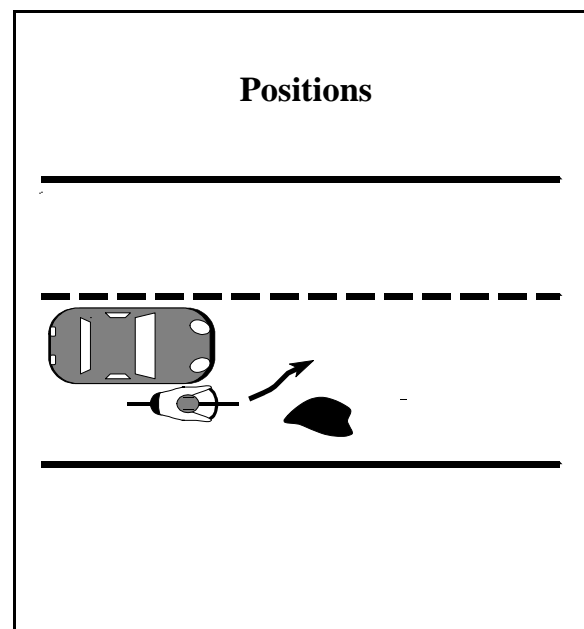
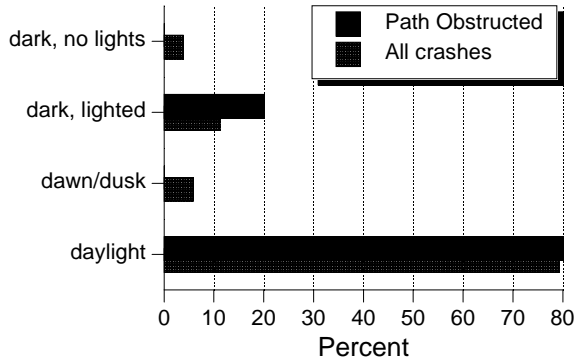

Figure 35. Positions in “Motorist Overtaking—
Bicyclist Path Obstructed.”

Motorist Overtaking—Bicyclist Path Obstructed

Light Condition



Number of Lanes

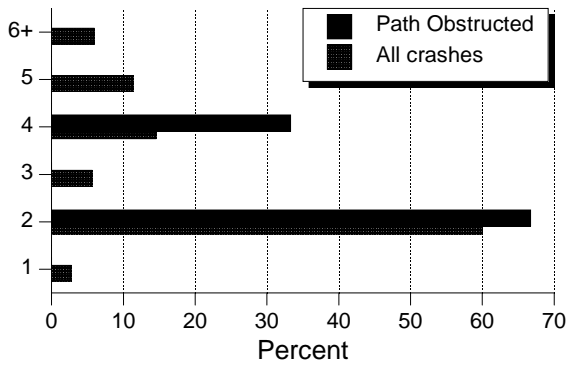

Speed Limit

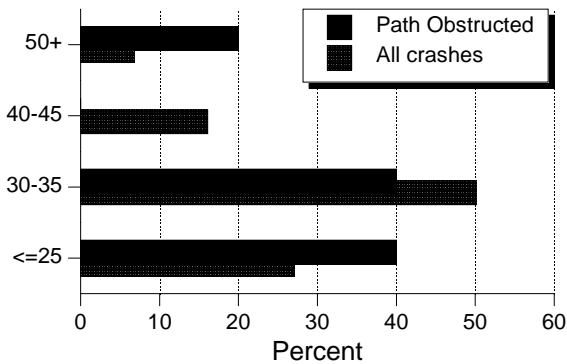

Development Character

- ▶ Urban 60%
- ▶ Rural 40%

Road Feature

- ▶ No special feature . 100%

Positions

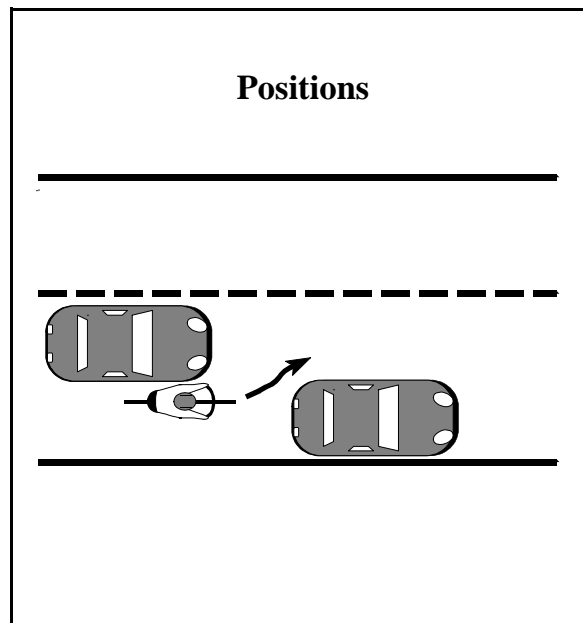

Bicyclist Left Turn In Front Of Traffic

Frequency: 130 cases; 4.3% of all crashes
Severity: 28% resulted in serious and fatal injuries

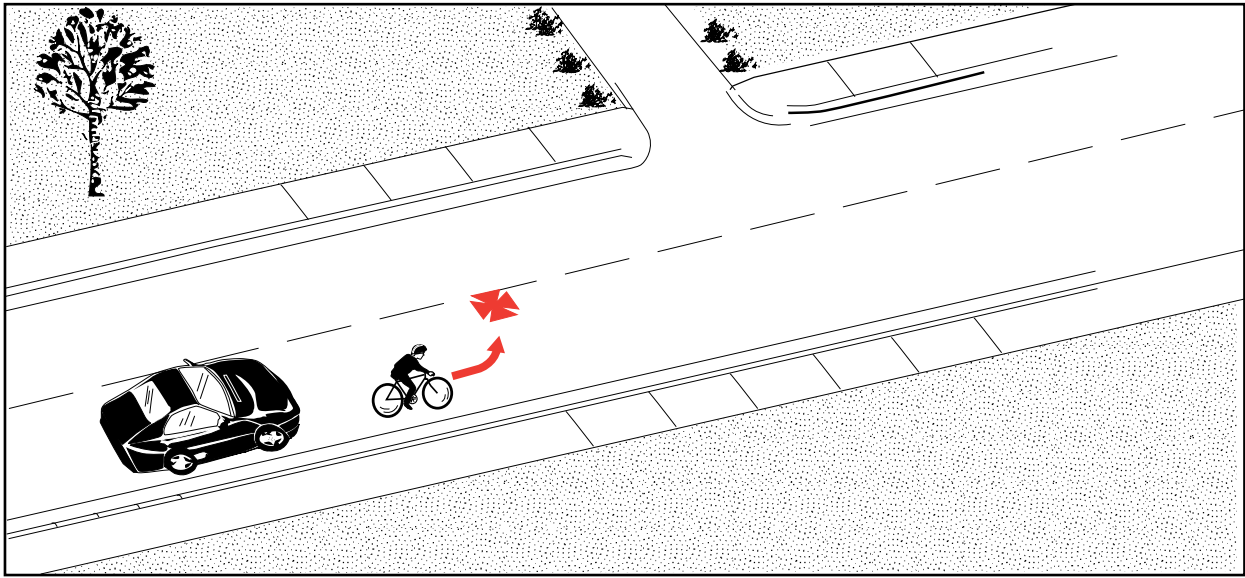

Description: The bicyclist made a left turn in front of traffic traveling in the same direction.

Summary: In comparison to all crashes, this crash was more likely to involve youth (age 10 to 14) bicyclists and occur on high-speed, 2-lane roads.

Slightly more than 60 percent of these events took place at a midblock location which had no special feature.

These crashes tended to be more severe than the average.

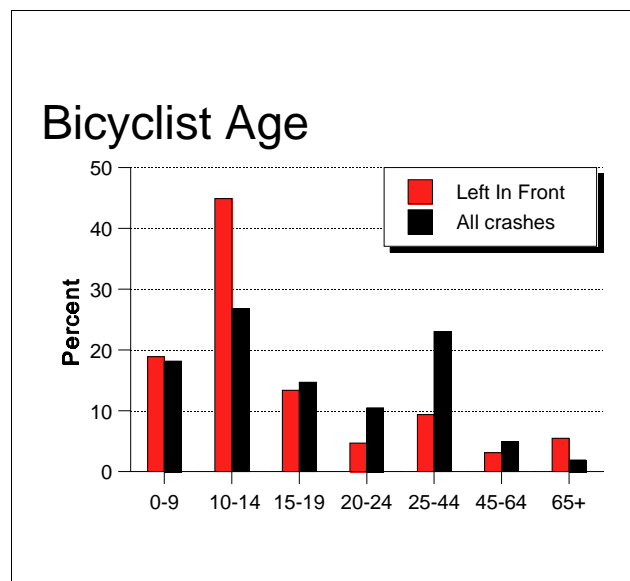
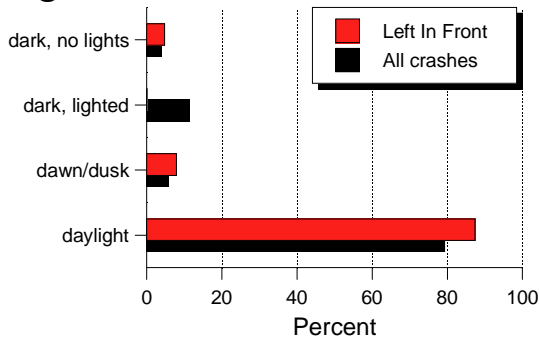

Figure 14. Bicyclist age in “Bicyclist Left Turn In Front Of Traffic.”

Bicyclist Left Turn In Front Of Traffic

Light Condition



Number of Lanes

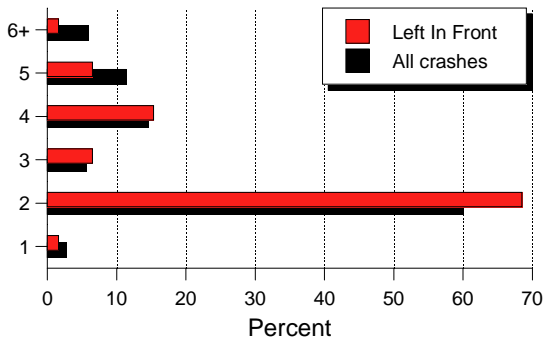

Speed Limit (km/h)

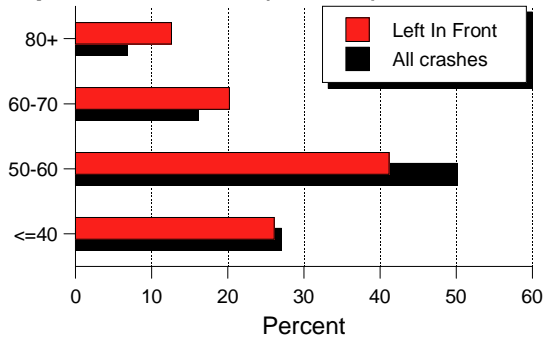

Figure15. Light condition, number of lanes, and speed limit in “Bicyclist Left Turn In Front Of Traffic.”

Development Character

- ▶ Urban 64%
- ▶ Rural 36%

Traffic Control

- ▶ None 92%
- ▶ Traffic Signal 4%
- ▶ Stop Sign 2%
- ▶ Other 2%

Road Feature

- ▶ No special feature .. 62%
- ▶ Intersection 27%
- ▶ Driveway/Alley 8%
- ▶ Other 3%

Positions

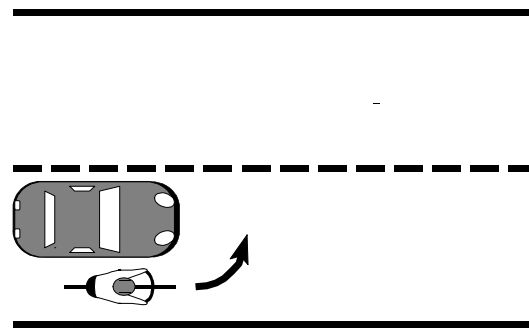

More than 3 out of 5 occurred at a midblock location with no special feature.

Figure 16. Positions in “Bicyclist Left Turn In Front Of Traffic.”

Bicyclist Left Turn—Facing Traffic

Frequency: 25 cases; 0.8% of all crashes
Severity: 26% resulted in serious or fatal injuries

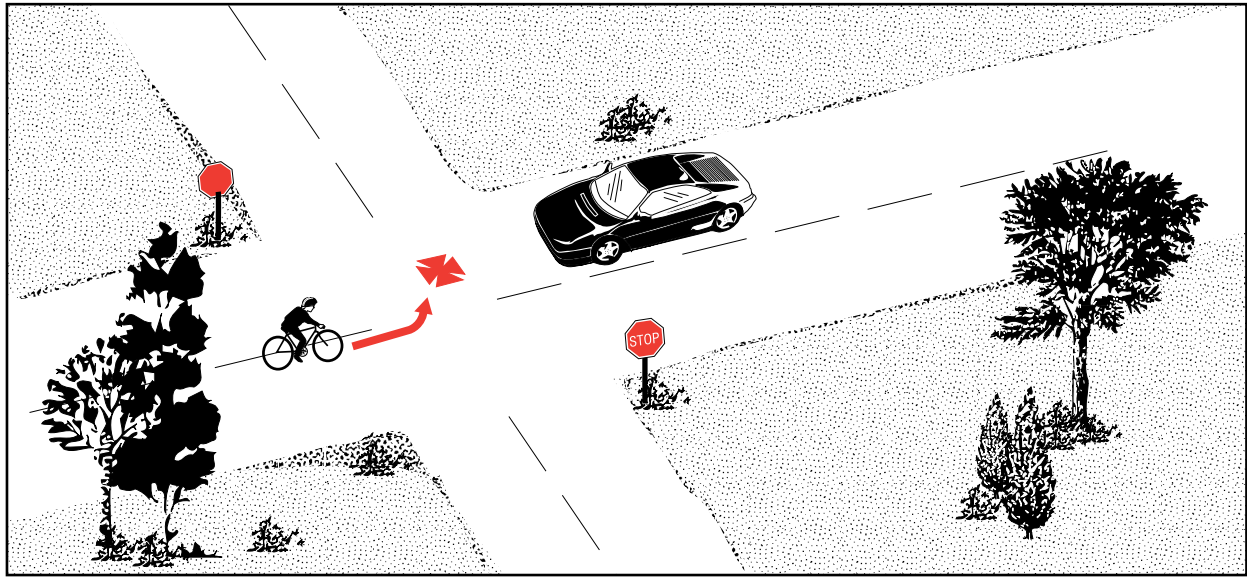

Description: The bicyclist made a left turn in front of facing approach traffic.

Summary: In comparison to all crashes, this crash was more likely to involve child (age 0 to 9) bicyclists.

Almost 50 percent occurred on high-speed (60 to 70 km/h) and very high-speed (80+ km/h) roads combined. More than 50 percent took place in rural areas.

A moving or stopped vehicle was a vision obstruction in 16 percent of the crashes. The road condition was wet in 13 percent.

This event tended to be more severe than the average.

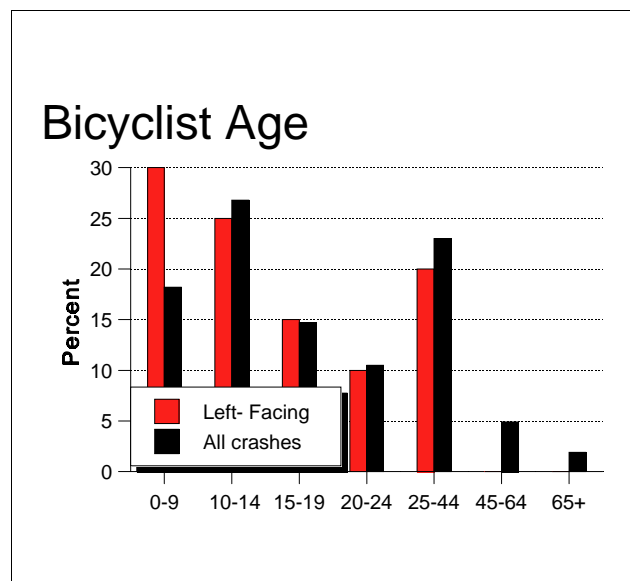
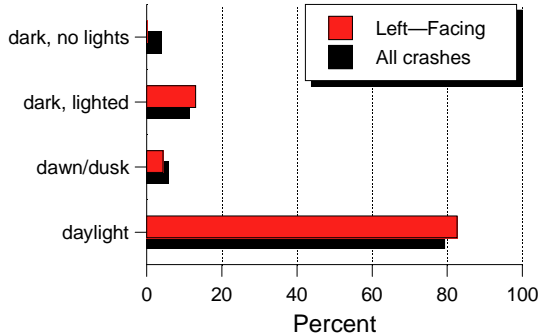

Figure 17. Bicyclist age in “Bicyclist Left Turn—Facing Traffic.”

Bicyclist Left Turn—Facing Traffic

Light Condition



Number of Lanes

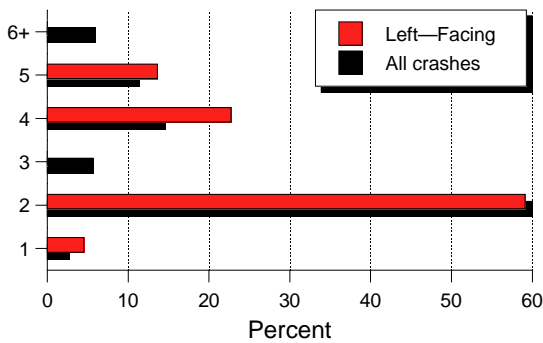

Speed Limit (km/h)

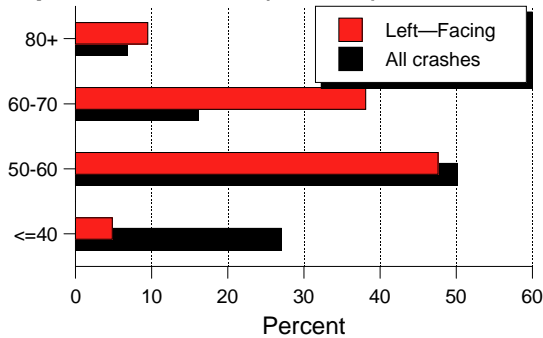

Figure 18. Light condition, number of lanes, and speed limit in “Bicyclist Left Turn—Facing Traffic.”

Development Character

- ▶ Urban 48%
- ▶ Rural 52%

Traffic Control

- ▶ None 68%
- ▶ Traffic Signal 20%
- ▶ Stop Sign 8%
- ▶ Other 4%

Road Feature

- ▶ Intersection 52%
- ▶ No special feature .. 36%
- ▶ Driveway/Alley 8%
- ▶ Other 4%

Positions

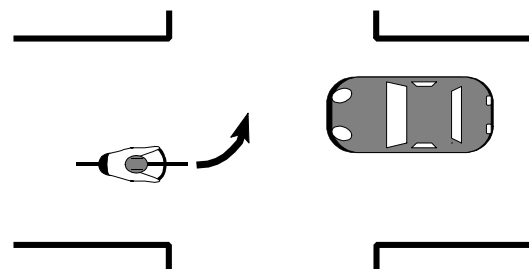

While most occurred at intersections, more than 1/3 took place at a midblock location with no special feature.

Figure 19. Positions in “Bicyclist Left Turn—Facing Traffic.”

Bicyclist Lost Control

Frequency: 35 cases; 1.2% of all crashes
Severity: 33% resulted in serious or fatal injuries

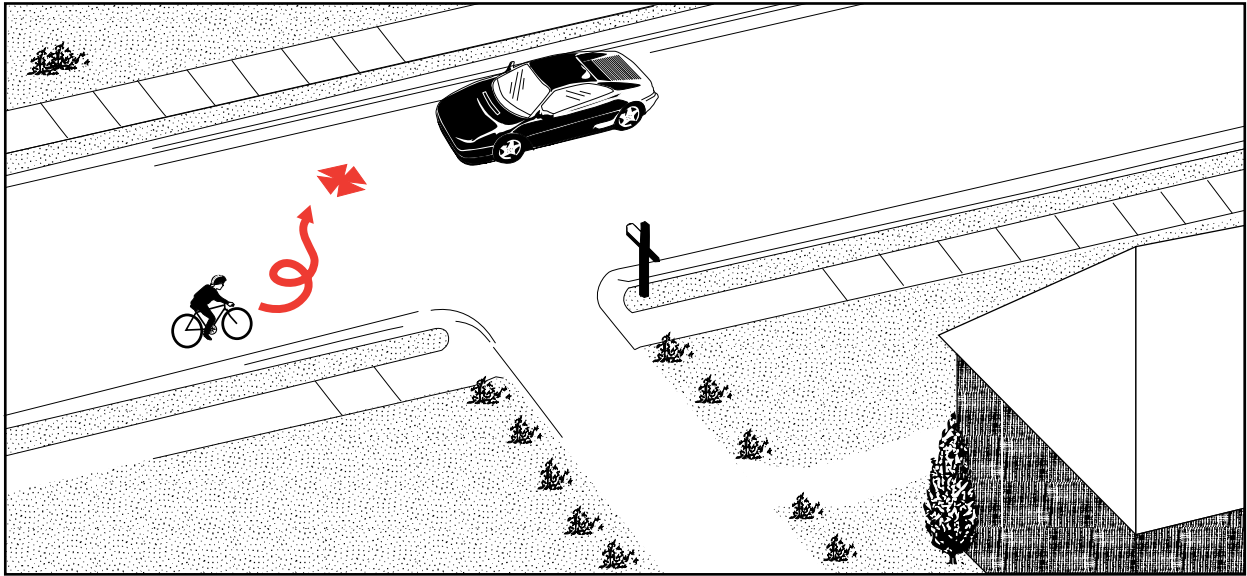

Description: The bicyclist lost control and inadvertently swerved into the path of the motorist.

Summary: In comparison to all crashes, this crash was more likely to involve child (age 0 to 9) and adult (age 25 to 44) bicyclists.

The light condition, number of lanes, and speed limit parameters generally followed the results for all crashes combined.

Forty two percent of adult bicyclists age 25 and older had been drinking.

Fourteen percent of these crashes occurred on a curve. “Bicyclist Lost Control” crashes were much more serious than the average.

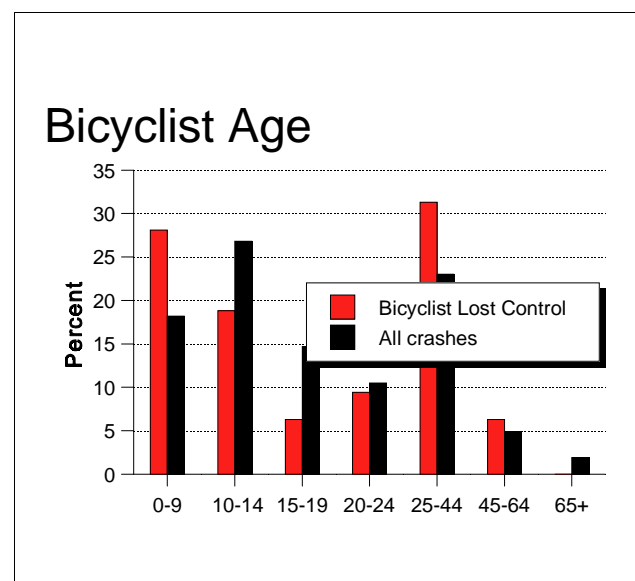
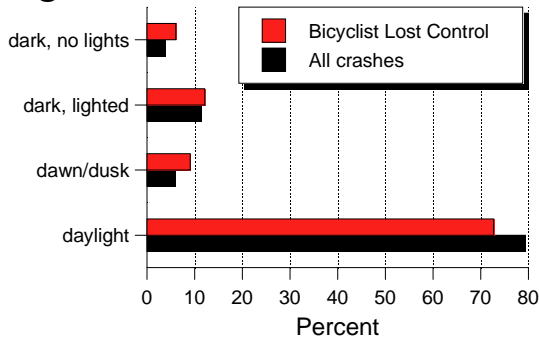

Figure 48. Bicyclist age in “Bicyclist Lost Control.”

Bicyclist Lost Control

Light Condition



Number of Lanes

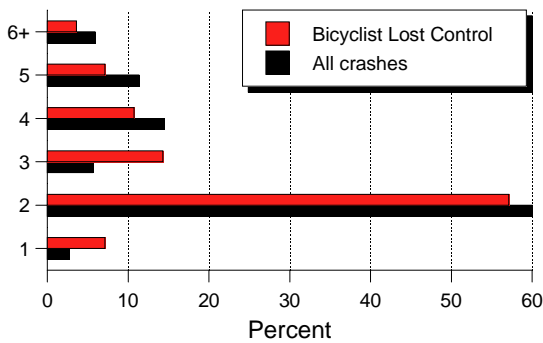

Speed Limit (km/h)

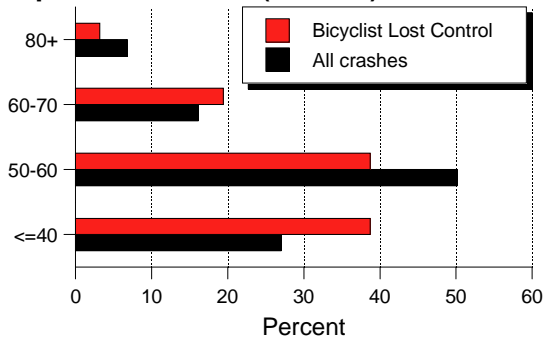

Figure 49. Light condition, number of lanes, and speed limit in “Bicyclist Lost Control.”

Development Character

- ▶ Urban 64%
- ▶ Rural 36%

Traffic Control

- ▶ None 80%
- ▶ Traffic Signal 9%
- ▶ Stop Sign 9%
- ▶ Other 3%

Road Feature

- ▶ No special feature .. 69%
- ▶ Intersection 23%
- ▶ Driveway 9%

Positions

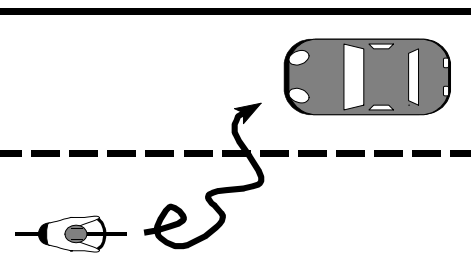

More than 2/3 occurred at a midblock location with no special feature.

Figure 50. Positions in “Bicyclist Lost Control.”

Bicyclist Right Turn

Frequency: 43 cases; 1.4% of all crashes
Severity: 27% resulted in serious or fatal injuries

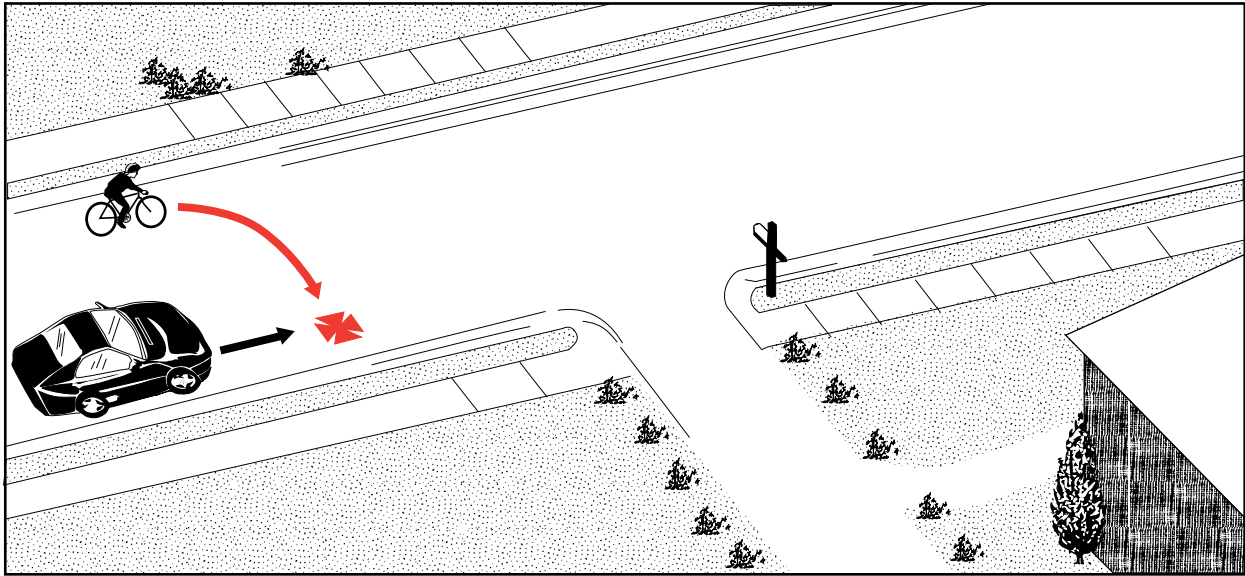

Description: The bicyclist was making a right turn while riding facing traffic.

Summary: In comparison to all crashes, this crash was more likely to involve child (age 0 to 9) and youth (age 10 to 14) bicyclists.

More than 20 percent occurred on very high-speed (80+ km/h) roads.

More than 40 percent occurred in rural areas.

Only 1/3 occurred at roadway intersections.

This event tended to be more severe than the average.

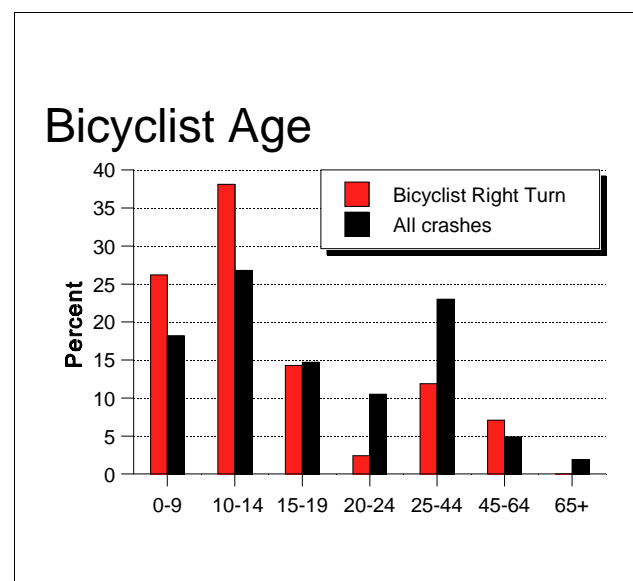
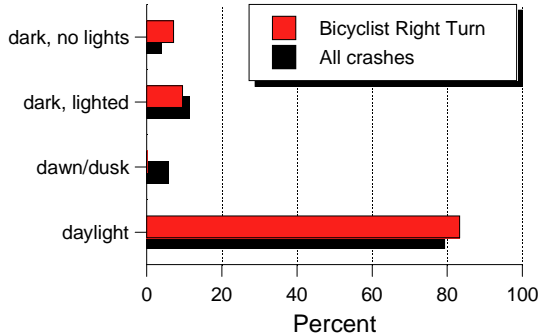

Figure 20. Bicyclist age in “Bicyclist Right Turn.”

Bicyclist Right Turn

Light Condition



Number of Lanes

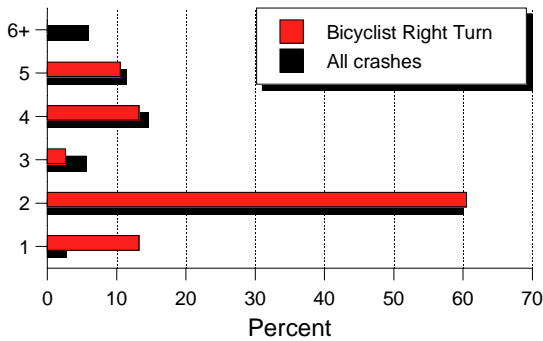

Speed Limit (km/h)

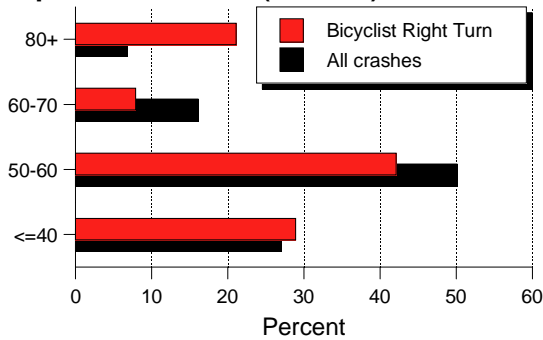

Figure 21. Light condition, number of lanes, and speed limit in “Bicyclist Right Turn.”

Development Character

- ▶ Urban 59%
- ▶ Rural 41%

Traffic Control

- ▶ None 92%
- ▶ Traffic Signal 5%
- ▶ Stop Sign 3%

Road Feature

- ▶ No special feature . . . 68%
- ▶ Intersection 32%

Positions

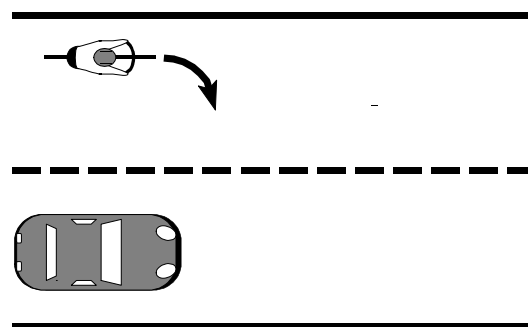

More than 2/3 occurred at a midblock location with no special feature.

Figure 22. Positions in “Bicyclist Right Turn.”

Motorist Left Turn In Front Of Bicyclist

Frequency: 36 cases; 1.2% of all crashes
Severity: 9% resulted in serious or fatal injuries

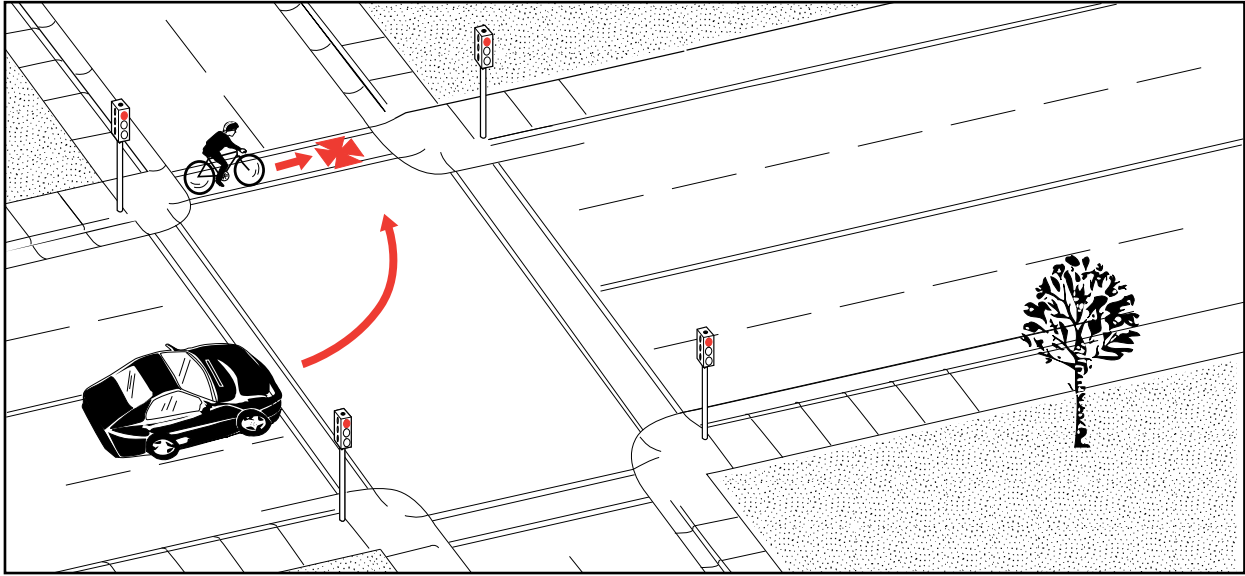

Description: Both parties were traveling in the same direction and the motorist turned left in front of the bicyclist.

Summary: In comparison to all crashes, this crash was more likely to involve young adult (age 20 to 24) bicyclists and take place on multilane roads (4, 5, and 6+ lanes).

Seventy five percent of these crashes took place at an intersection.

Almost 4 out of 5 bicyclists were riding facing traffic either in the roadway or in the “off road” position.

This crash tended to be less serious than the average. There were no fatalities.

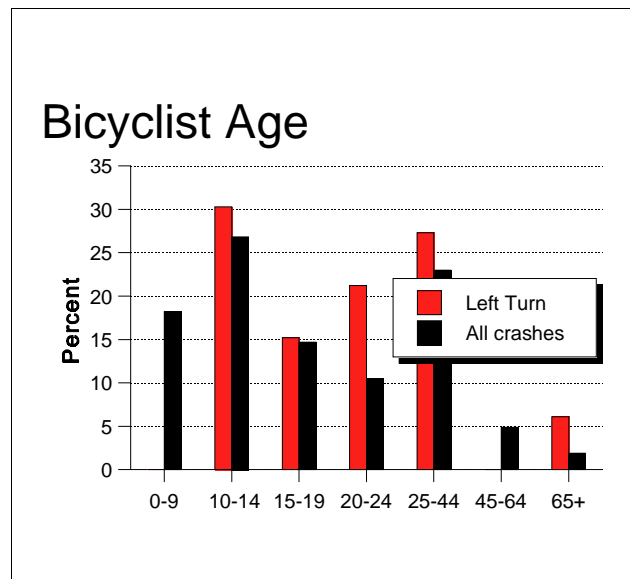
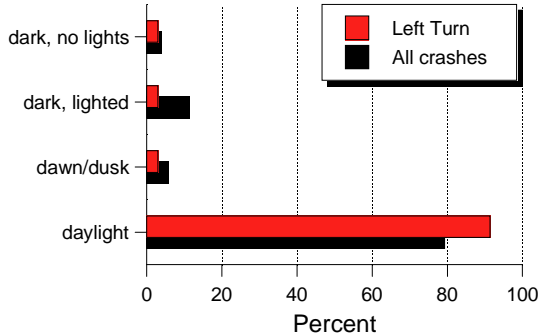

Figure 2. Bicyclist age in “Motorist Left Turn In Front Of Bicyclist.”

Motorist Left Turn In Front Of Bicyclist

Light Condition



Number of Lanes

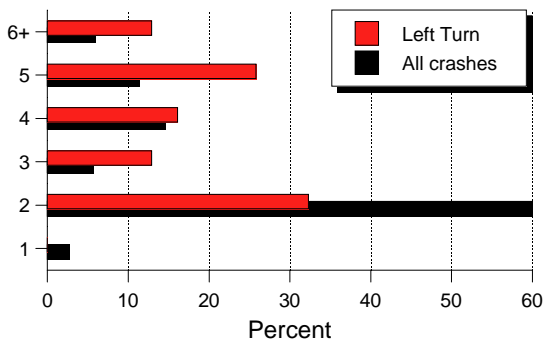

Speed Limit (km/h)

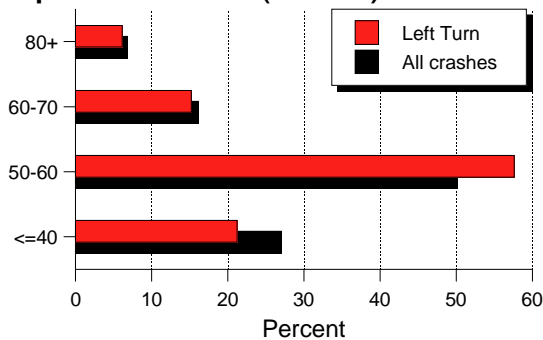

Figure 3. Light condition, number of lanes, and speed limit in “Motorist Left Turn In Front Of Bicyclist.”

Development Character

- ▶ Urban 71%
- ▶ Rural 29%

Traffic Control

- ▶ None 56%
- ▶ Traffic Signal 33%
- ▶ Stop Sign 8%
- ▶ Other 3%

Road Feature

- ▶ Intersection 75%
- ▶ Public Driveway ... 11%
- ▶ Private Driveway ... 5%
- ▶ Other 9%

Positions

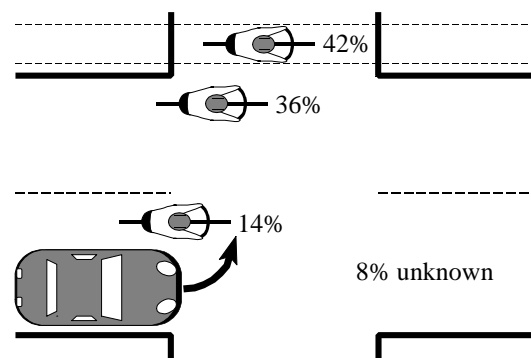

Almost 4 out of 5 bicyclists were riding facing traffic.

Figure 4. Positions in “Motorist Left Turn In Front Of Bicyclist.”

Motorist Left Turn—Facing Bicyclist

Frequency: 176 cases; 5.9% of all crashes
Severity: 24% resulted in serious or fatal injuries

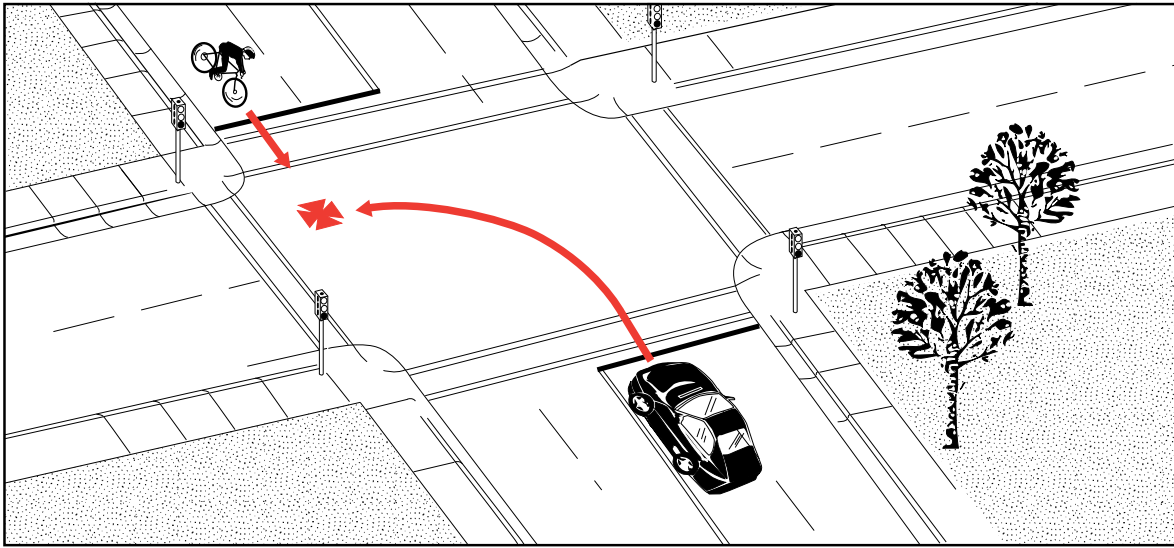

Description: The motorist made a left turn while facing the approaching bicyclist.

Summary: In comparison to all crashes, this crash was more likely to involve young adult (age 20 to 24) and adult (age 25 to 44) bicyclists who accounted for more than 70 percent.

More than 50 percent took place on multilane roads (4, 5, and 6+ lanes). More than 60 percent were on roads with a 50 to 60 km/h speed limit. Twenty percent took place under dark, lighted conditions.

Sun glare was a factor for 6 percent of drivers, and a moving or stopped vehicle was a visual obstruction for 9 percent.

Bicyclists were riding in a bicycle lane in 5 percent of these crashes. Bicycle lanes were present in 2 percent of all crash types combined.

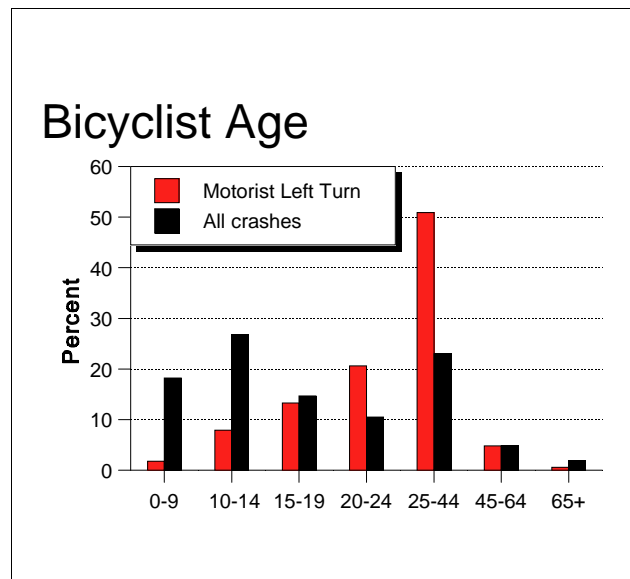
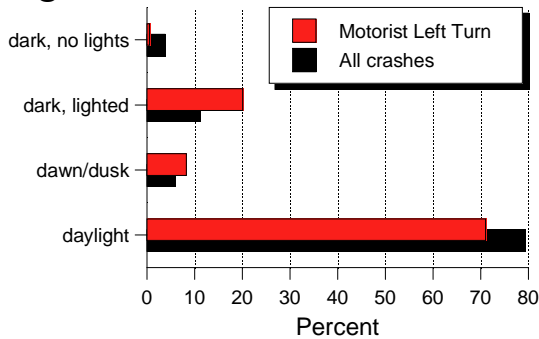

Figure 5. Bicyclist age in “Motorist Left Turn—Facing Bicyclist.”

Motorist Left Turn—Facing Bicyclist

Light Condition



Number of Lanes

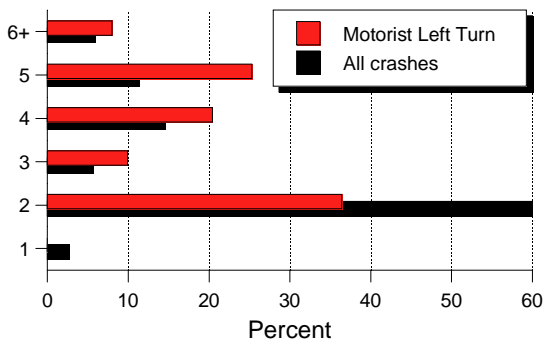

Speed Limit (km/h)

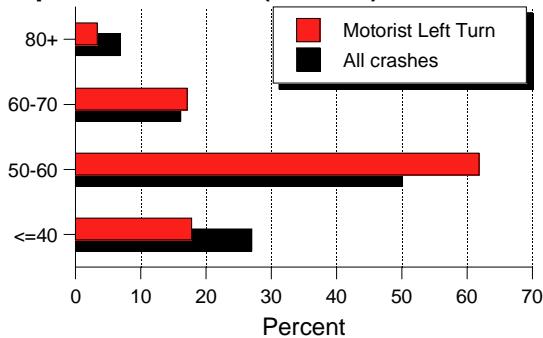

Figure 6. Light condition, number of lanes, and speed limit in “Motorist Left Turn—Facing Bicyclist.”

Development Character

- ▶ Urban 77%
- ▶ Rural 23%

Traffic Control

- ▶ None 56%
- ▶ Traffic Signal 30%
- ▶ Stop Sign 14%
- ▶ Other 1%

Road Feature

- ▶ Intersection 77%
- ▶ Public Driveway 17%
- ▶ Private Driveway 5%

Positions

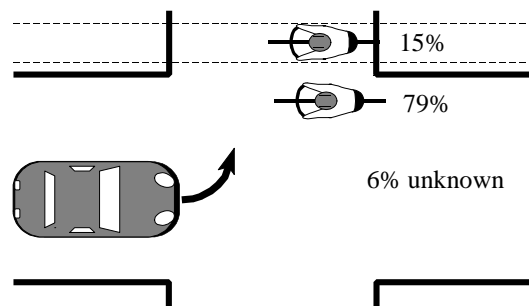

Almost 4 out of 5 bicyclists were riding in the “in road” position.

Figure 7. Positions in “Motorist Left Turn—Facing Bicyclist.”

Motorist Right Turn

Frequency: 143 cases; 4.7% of all crashes
Severity: 11% resulted in serious or fatal injuries

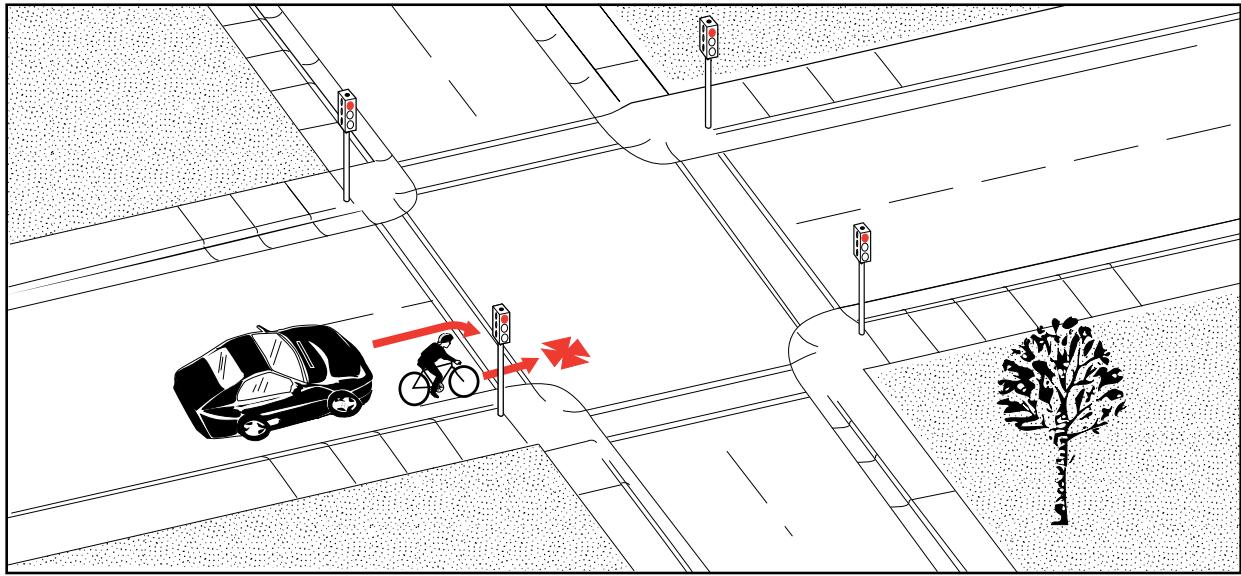

Description: The motorist was making a right turn and the bicyclist was riding in either the same or opposing direction.

Summary: In comparison to all crashes, this crash was more likely to involve young adult (age 20 to 24) and adult (age 25 to 44) bicyclists and take place on multilane roads (4, 5, and 6+ lanes).

More than 60 percent were on roads with a 50 to 60 km/h speed limit.

For the 113 cases in which the bicyclist was riding the same direction as traffic, the motorist was overtaking the bicyclist 74 percent of the time and the bicyclist was overtaking the motorist on the right 11 percent. The overtaking action was undetermined 15 percent of the time.

Bicyclists were riding in a bicycle lane in 8 percent of these crashes. Bicycle lanes were

present in only 2 percent of all the crash types combined.

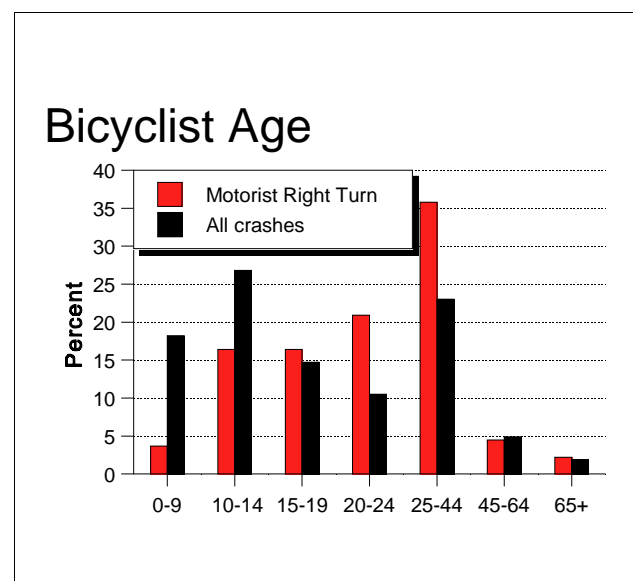
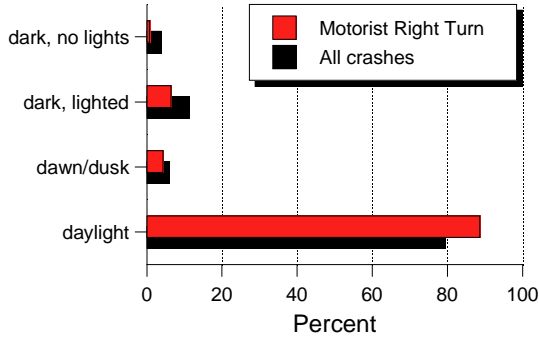

Figure 8. Bicyclist age in “Motorist Right Turn.”

Motorist Right Turn

Light Condition



Number of Lanes

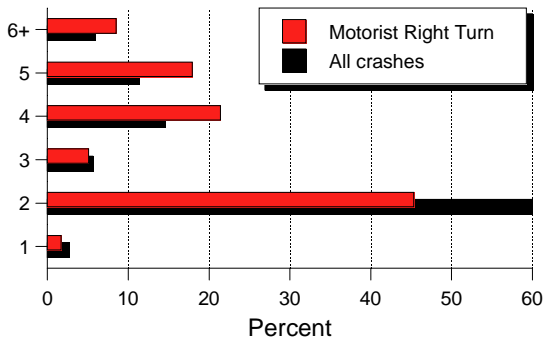

Speed Limit (km/h)

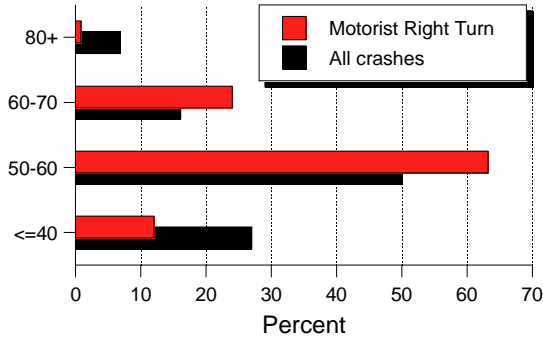

Figure 9. Light condition, number of lanes, and speed limit in “Motorist Right Turn.”

Development Character

- ▶ Urban 77%
- ▶ Rural 23%

Traffic Control

- ▶ None 57%
- ▶ Traffic Signal 28%
- ▶ Stop Sign 10%
- ▶ Other 5%

Road Feature

- ▶ Intersection 59%
- ▶ Public Driveway ... 27%
- ▶ Private Driveway .. 12%
- ▶ Other 2%

Positions

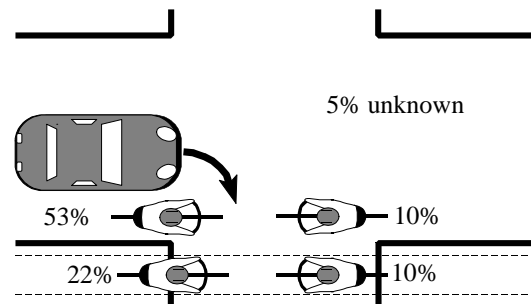

More than 1/2 of the bicyclists were in road riding with traffic. About 1/3 were in the “off road” position.

Figure 10. Positions in “Motorist Right Turn.”

Uncontrolled Intersection—Other

Frequency: 23 cases; 0.8% of all crashes
Severity: 14% resulted in serious or fatal injuries

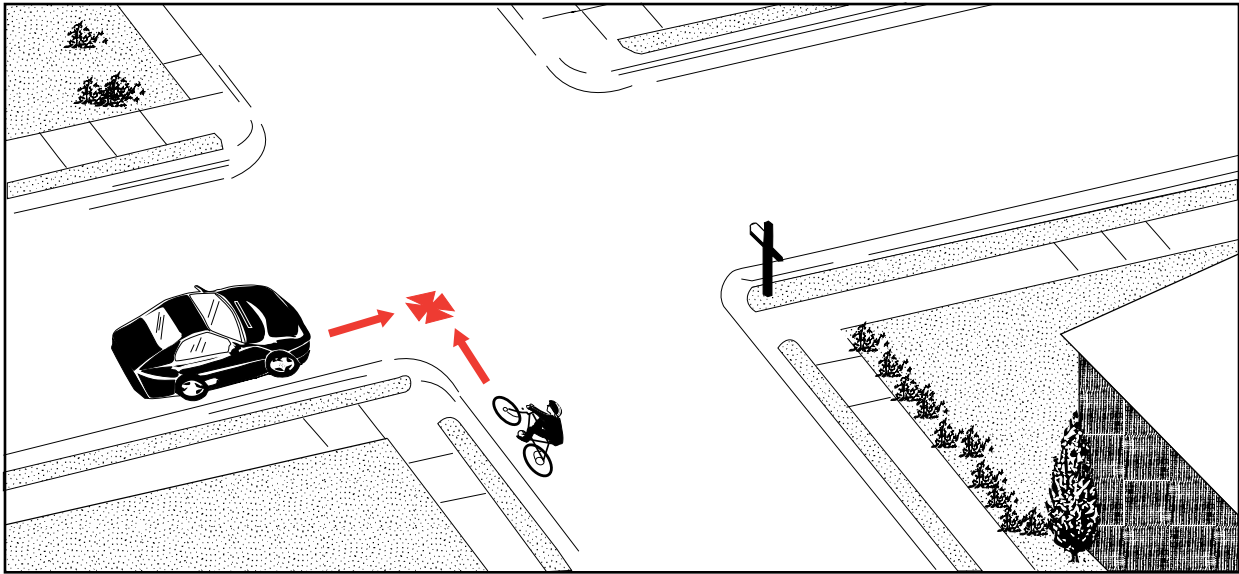

Description: The crash occurred at an intersection that had neither stop sign nor traffic signal, and did not conform to any of the other crash types.

Summary: In comparison to all crashes, this crash was more likely to involve child (age 0 to 9) bicyclists who accounted for more than 40 percent of these events. Middle (age 45 to 64) and elder adult (age 65+) bicyclists were not represented.

More than 70 percent occurred on two-lane roads, and more than 40 percent were on roads with a speed limit of 40 km/h or less.

More than 40 percent occurred in rural areas.

This crash tended to be less severe than the average. There were no fatalities.

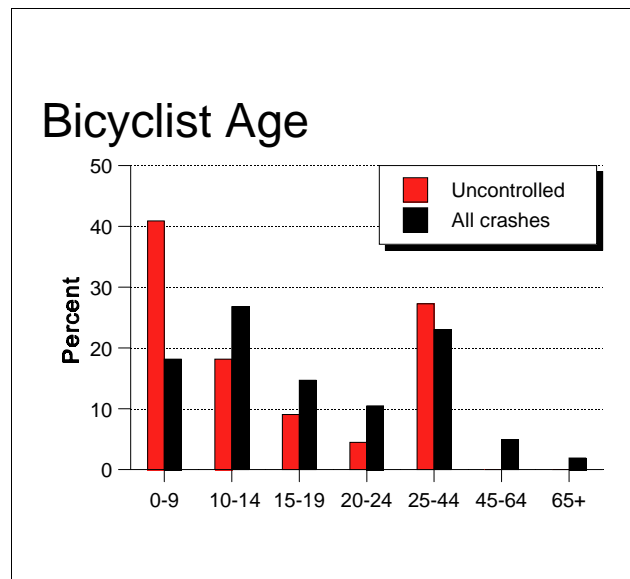
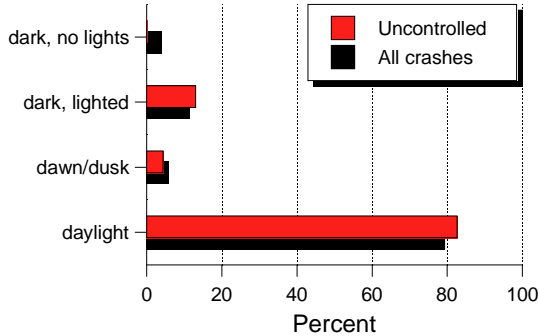

Figure 100. Bicyclist age in “Uncontrolled Intersection—Other.”

Uncontrolled Intersection—Other

Light Condition



Number of Lanes

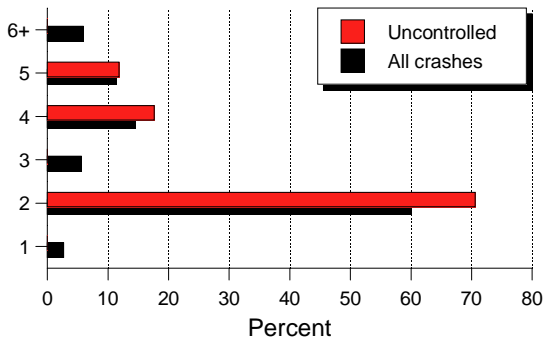

Speed Limit (km/h)

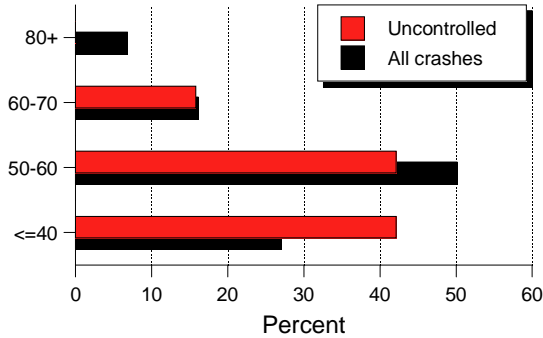

Figure 101. Light condition, number of lanes, and speed limit in “Uncontrolled Intersection—Other.”

Development Character

- ▶ Urban 59%
- ▶ Rural 41%

Positions

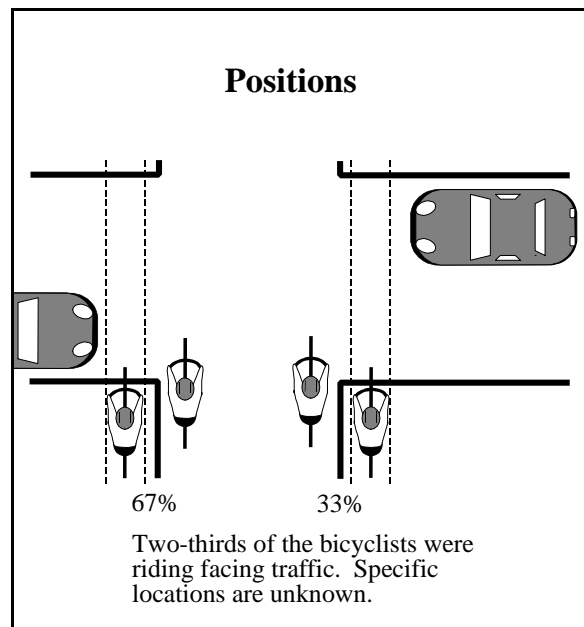
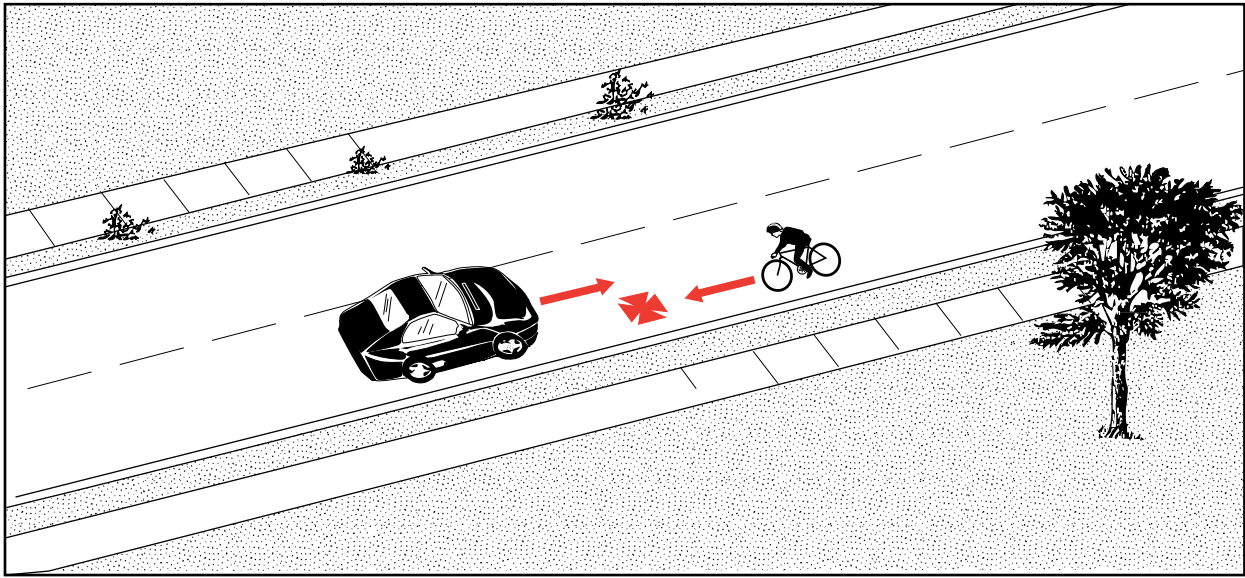

Figure 102. Positions in “Uncontrolled Intersection— Other.”

Wrong Way Bicyclist

Frequency: 81 cases; 2.7% of all crashes
Severity: 32% resulted in serious or fatal injuries



Description: The bicyclist was on a parallel path with the motorist and was riding in the roadway against traffic.

Summary: The bicyclist age distribution for this crash generally followed the pattern for all crashes combined.

More than 1/4 happened under conditions of darkness, with and without street lights.

Twenty two percent of adult bicyclists age 25 and older had been drinking. Twenty two percent were motorist hit & run.

In 7 percent of these events, the pre-crash evasive actions of both parties were counteractive.

This crash tended to be more severe than the average.

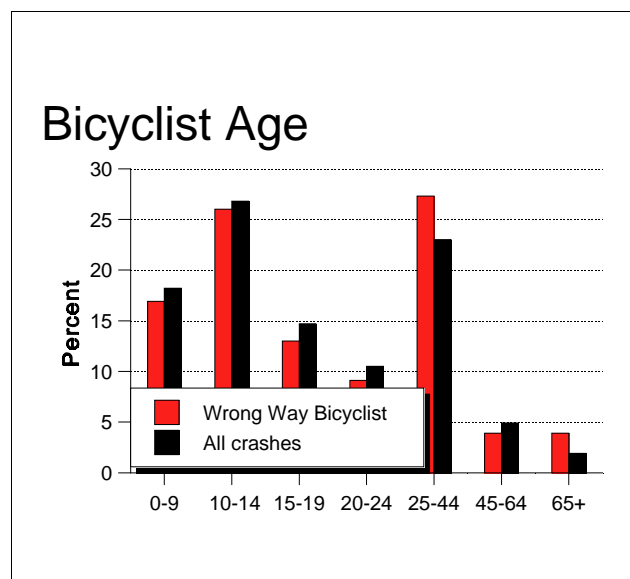
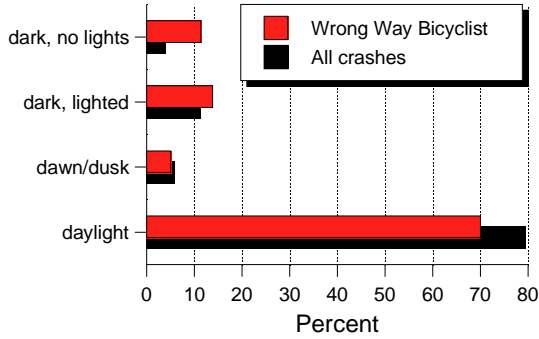

Figure 23. Bicyclist age in “Wrong Way Bicyclist.”

Wrong Way Bicyclist

Light Condition



Number of Lanes

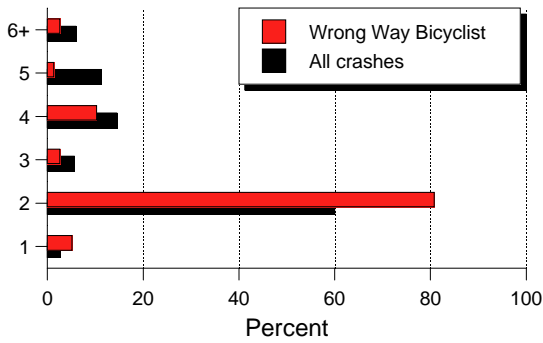

Speed Limit (km/h)

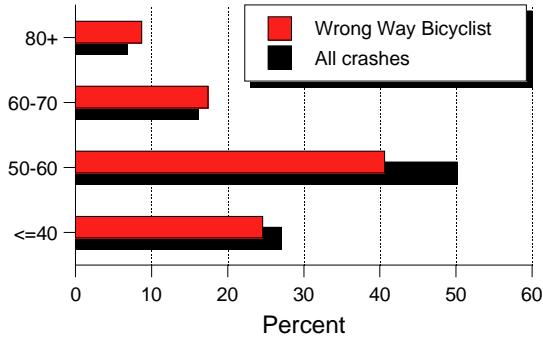

Figure 24. Light condition, number of lanes, and speed limit in “Wrong Way Bicyclist.”

Development Character

- ▶ Urban 59%
- ▶ Rural 41%

Road Feature

- ▶ No special feature . . 80%
- ▶ Intersection 14%
- ▶ Driveway/Alley 5%
- ▶ Other 1%

Positions

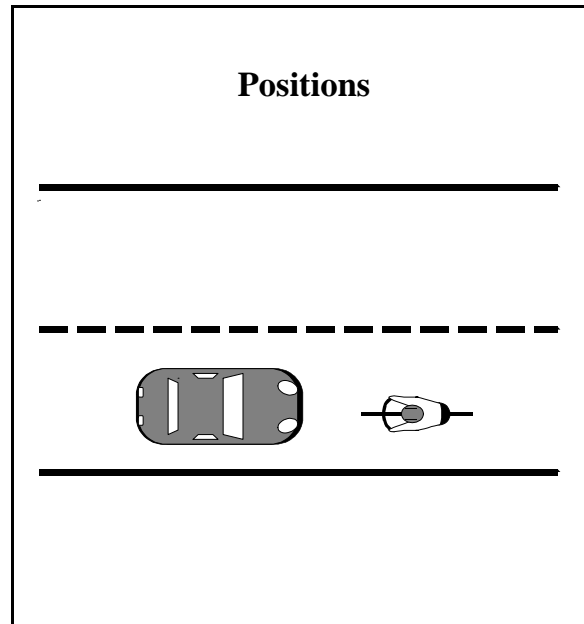
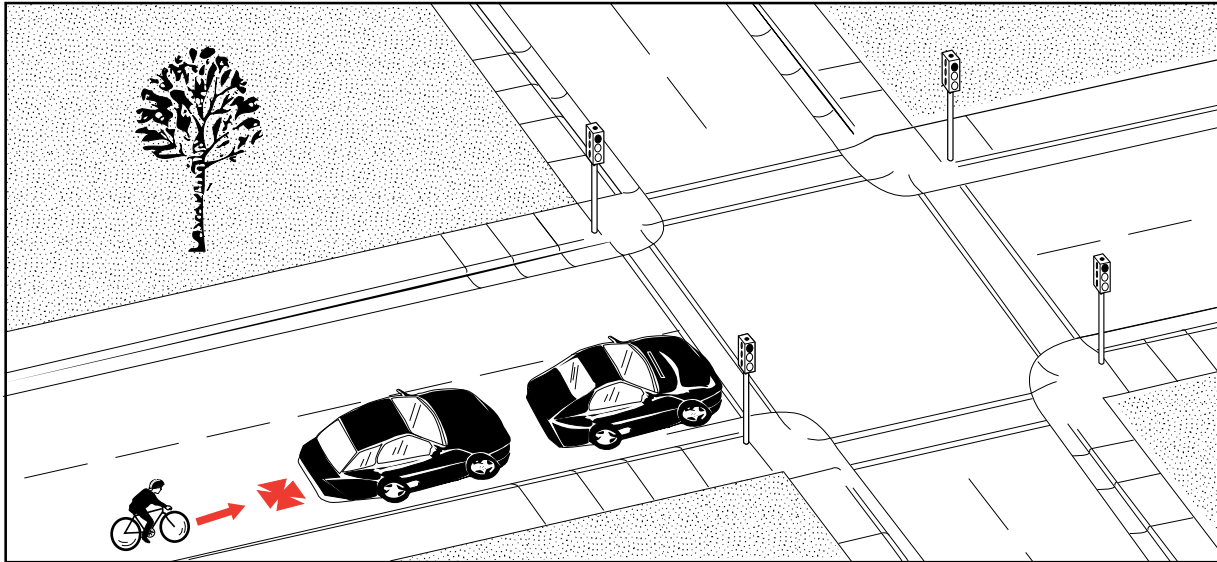

Figure 25. Positions in “Wrong Way Bicyclist.”

Bicyclist Overtaking

Frequency: 39 cases; 1.3% of all crashes
Severity: 5% resulted in serious or fatal injuries



Description: The bicyclist struck a slow or stopped motor vehicle in a travel lane.

Summary: In comparison to all crashes, this crash was more likely to involve young adult (age 20 to 24) and adult (age 25 to 44) bicyclists. Elder adults (age 65+) were not represented.

Almost 60 percent occurred on streets with a 40 km/h or less speed limit. Almost 80 percent occurred in urban areas.

Some type of road/environmental contributing factor such as weather, vision obstruction, glare, etc. was noted in 30 percent of these crashes.

This crash had a far lower incidence of serious injuries than the average. There were no fatalities.

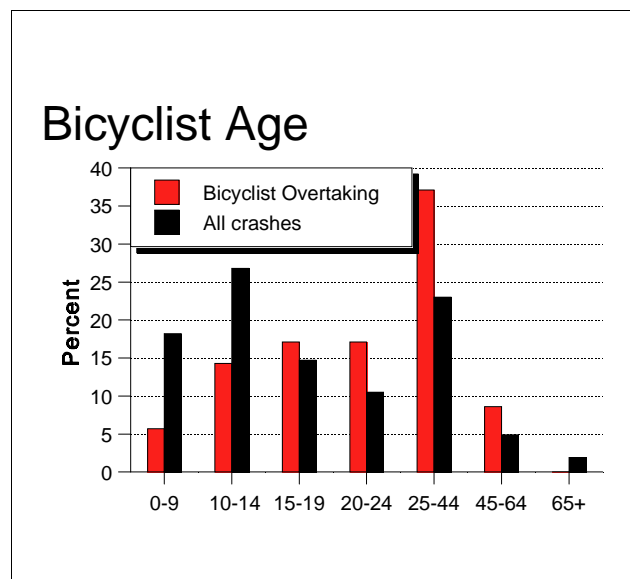
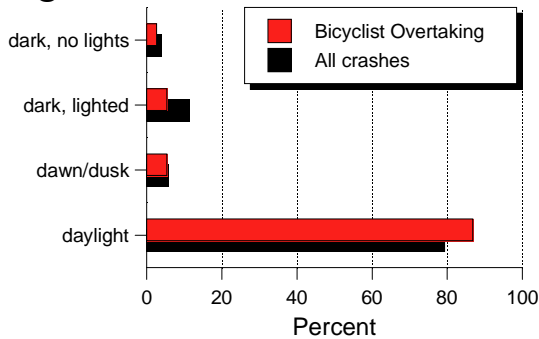

Figure 39. Bicyclist age in “Bicyclist Overtaking.”

Bicyclist Overtaking

Light Condition



Number of Lanes

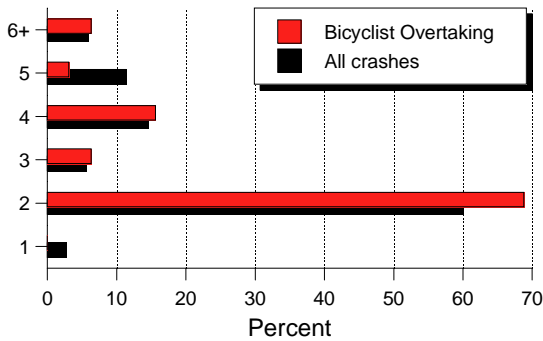

Speed Limit (km/h)

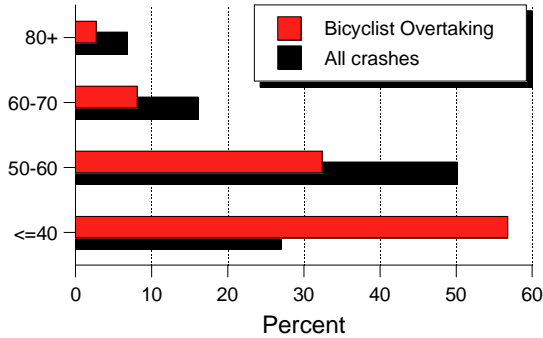

Figure 40. Light condition, number of lanes, and speed limit in “Bicyclist Overtaking.”

Development Character

- ▶ Urban 79%
- ▶ Rural 21%

Road Feature

- ▶ Intersection 41%
- ▶ No Special Feature 38%
- ▶ Public Driveway 10%
- ▶ Private Driveway 8%
- ▶ Other 3%

Positions

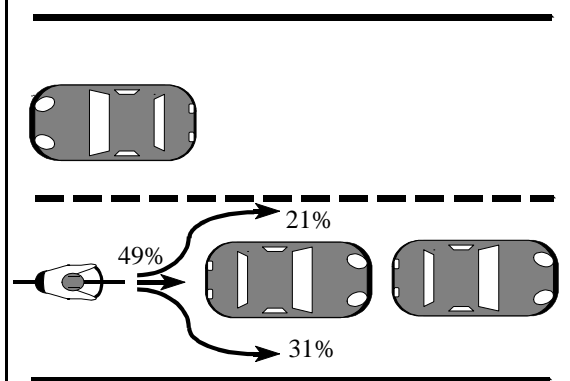

Almost 1/3 of the bicyclists were overtaking on the right.

Figure 41. Positions in “Bicyclist Overtaking.”

Wrong Way Motorist

Frequency: 3 cases; 0.1% of all crashes
Severity: 33% resulted in serious or fatal injuries

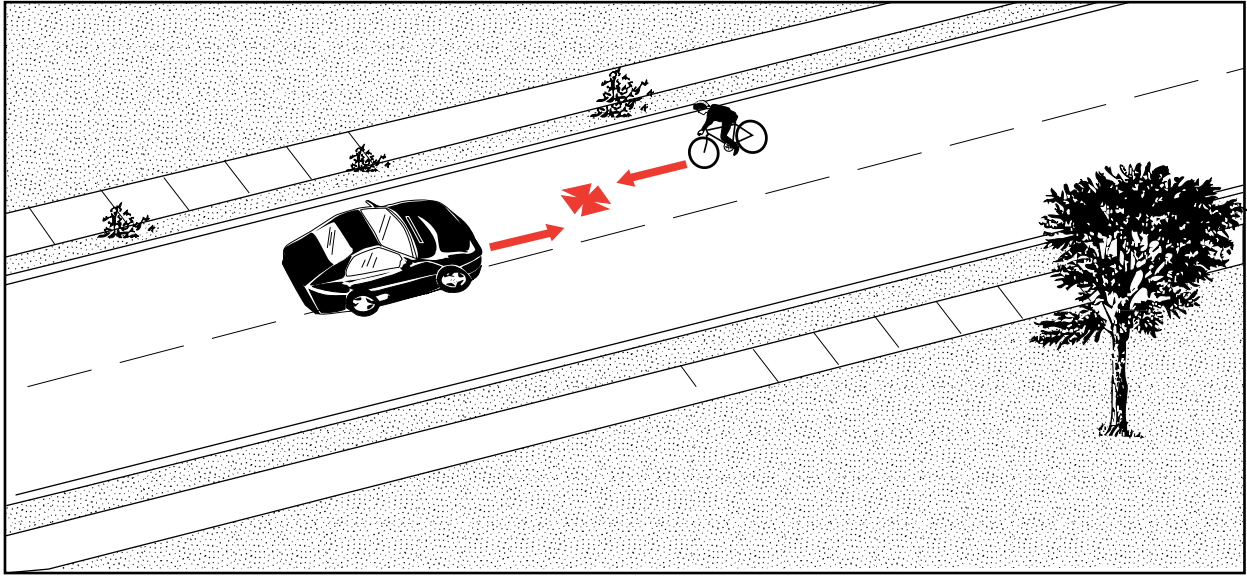

Description: For the few (n=3) crashes of this type, two occurred during daylight and one during darkness, no lights.

All three were in urban areas.

One was hit and run.

There were no fatalities.

Non - Roadway

Frequency: 112 cases; 3.7% of all crashes
Severity: 11% resulted in serious or fatal injuries

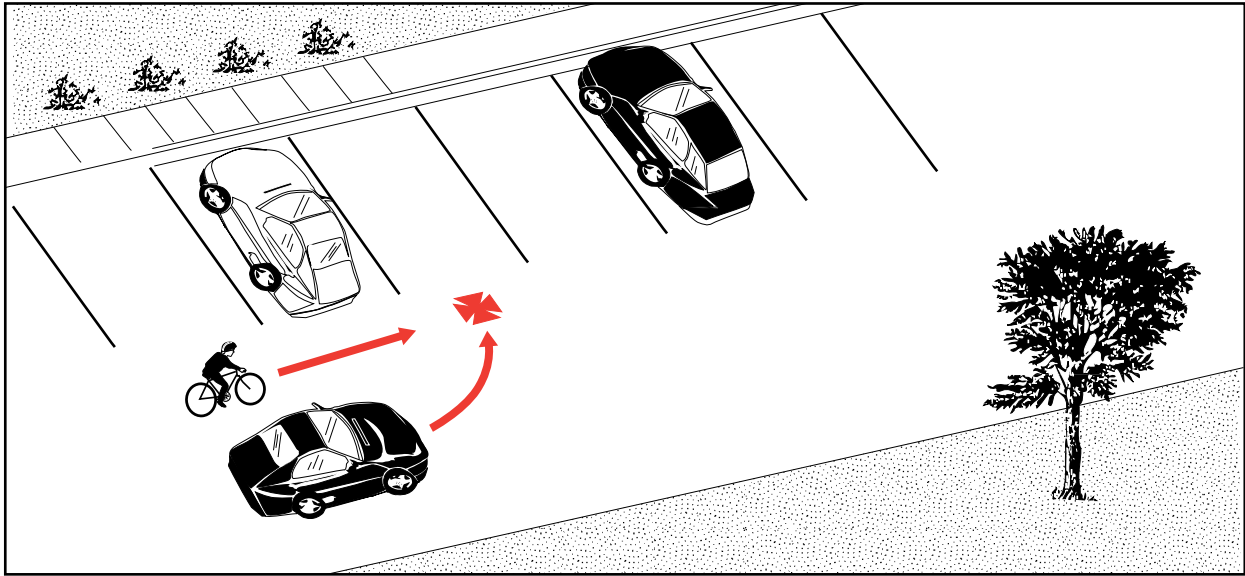

Description: The crash occurred in a non-roadway location such as parking lot, driveway/alley, open area, etc.

Summary: In comparison to all crashes, this crash was more likely to involve child (age 0 to 9) and youth (age 10 to 14) bicyclists.

Seventy one percent occurred in a parking lot, and 22 percent in a driveway or alley.

If the non-roadway crashes from the “Weird,” “Play Vehicle,” and “Backing” crashes types are included, the total frequency of “Non-Roadway” amounts to 141 cases and 4.7 percent of all crashes.

This crash had a lower incidence of serious injuries than the average. There were no fatalities.

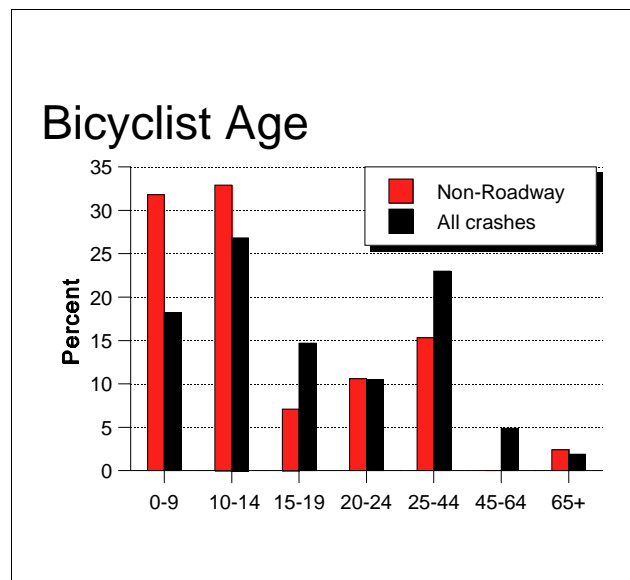
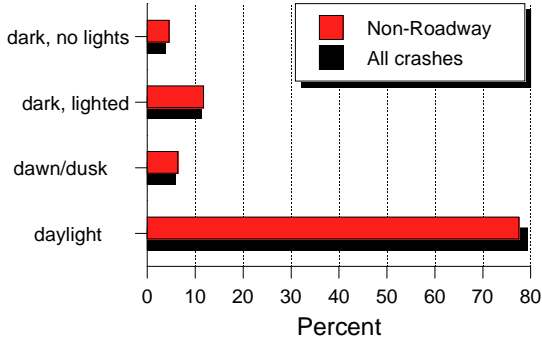

Figure 111. Bicyclist age in “Non-Roadway.”

Non-Roadway

Light Condition



Number of Lanes

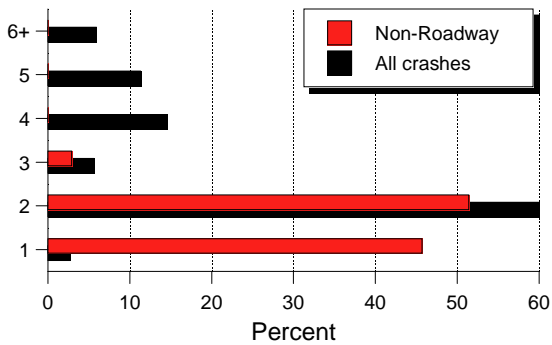

Speed Limit (km/h)

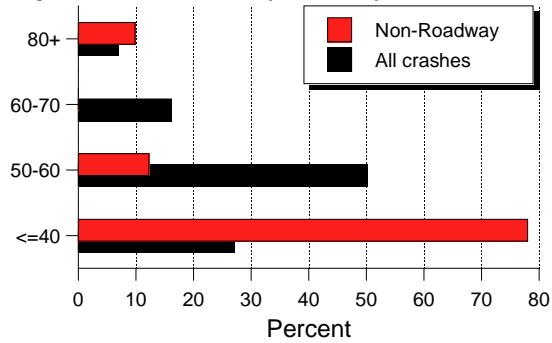

Figure 112. Light condition, number of lanes, and speed limit in “Non-Roadway.”

Development Character

- ▶ Urban 66%
- ▶ Rural 34%

Non-Roadway Location

- ▶ Parking lot 71%
- ▶ Driveway/Alley ... 22%
- ▶ Sidewalk 4%
- ▶ Other 4%

Example Parking Lot Positions

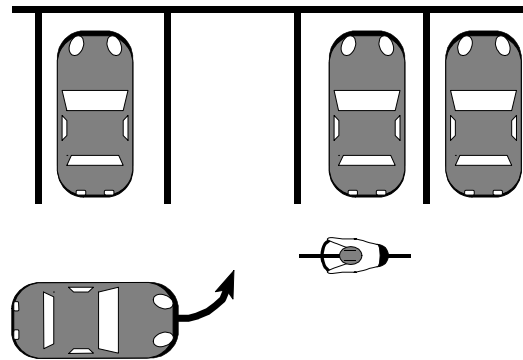

Parking lot locations accounted for 71% of this crash type.

Figure 113. Positions in “Non-Roadway.”

Drive Out From On-Street Parking

Frequency: 10 cases; 0.3% of all crashes
Severity: 11% resulted in serious or fatal injuries

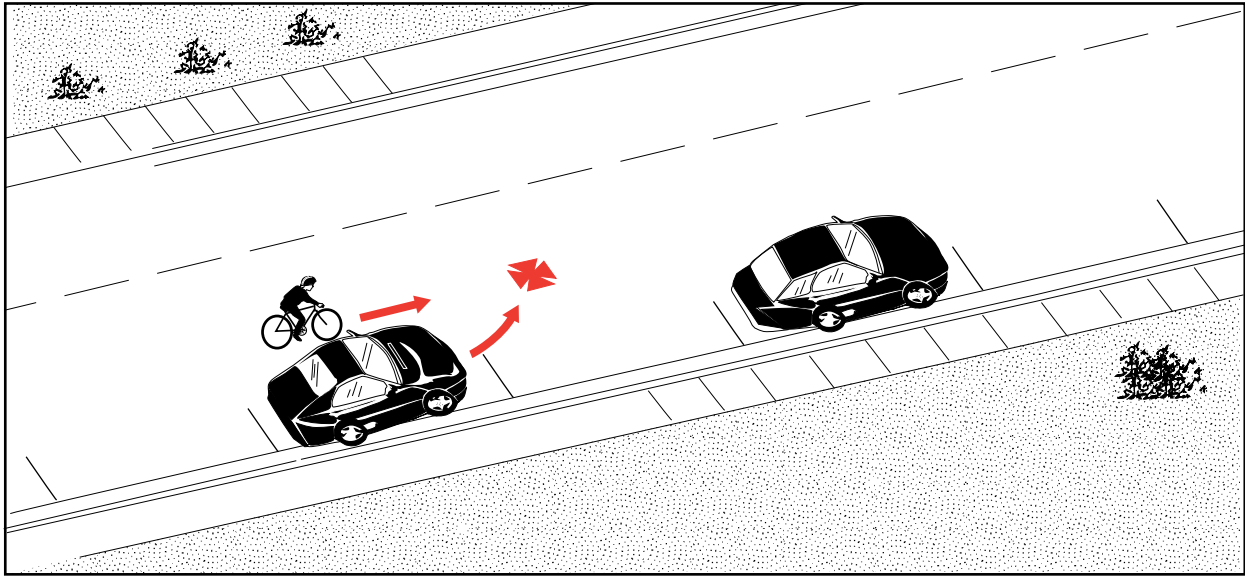

Description: The motorist was exiting or entering on-street parking.

Summary: For the few (n=10) crashes of this type, the vast majority involved a motorist pulling out from a parking space. Teen (age 15 to 19), young adult (age 20 to 24) and adult (age 25 to 44) bicyclists were represented.

Four of the ten crashes occurred under low light conditions. All took place in urban areas and half on streets with a speed limit of 40 km/h or less.

This crash tended to be less severe than the average. There were no fatalities.

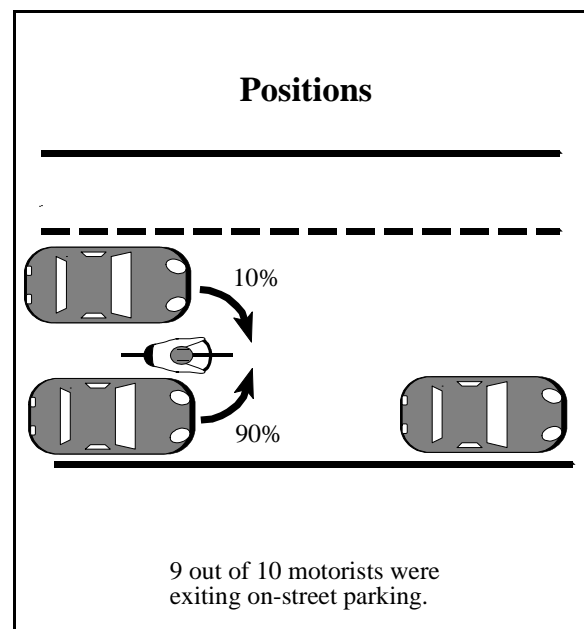
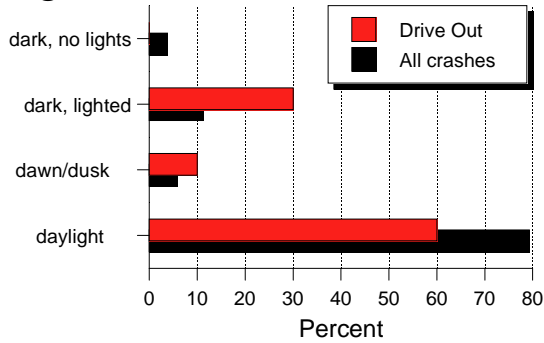

Figure 1. Positions in "Drive Out From On-Street Parking."

Drive Out From On-street Parking

Light Condition



Number of Lanes

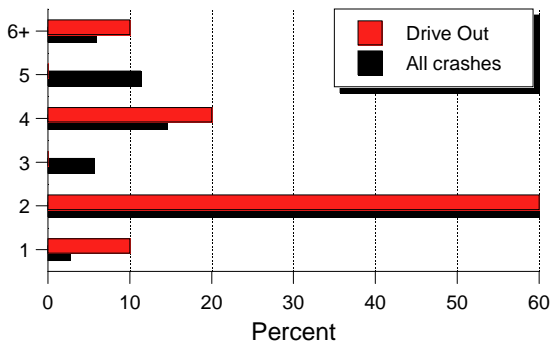

Speed Limit (km/h)

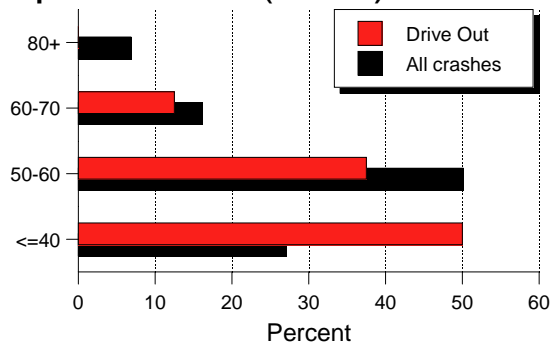

Figure 1. Light condition, number of lanes, and speed limit in “Drive Out From On-Street Parking.”

Development Character

- ▶ Urban 100%
- ▶ Rural 0%

Positions

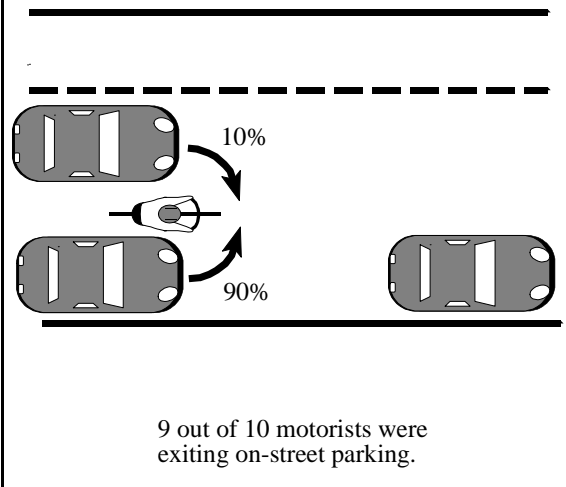

Figure 1. Positions in “Drive Out From On-Street Parking.”

Weird

Frequency: 34 cases; 1.1% of all crashes
Severity: 22% resulted in serious or fatal injuries

No drawing

Description: The crash was weird because:

- ▶ The motorist intentionally caused the crash.
- ▶ The bicyclist was struck by falling cargo, extended cargo, construction equipment, etc.
- ▶ Of other unusual circumstances.

Summary: In comparison to all crashes, this crash was more likely to involve teen (age 15 to 19), young adult (age 20 to 24), and adult (age 25 to 44) bicyclists.

About 30 percent occurred under low light conditions.

Twenty-four percent were hit & run, and 24 percent were assault with motor vehicle.

This crash was slightly more severe than the average. There were no fatalities.

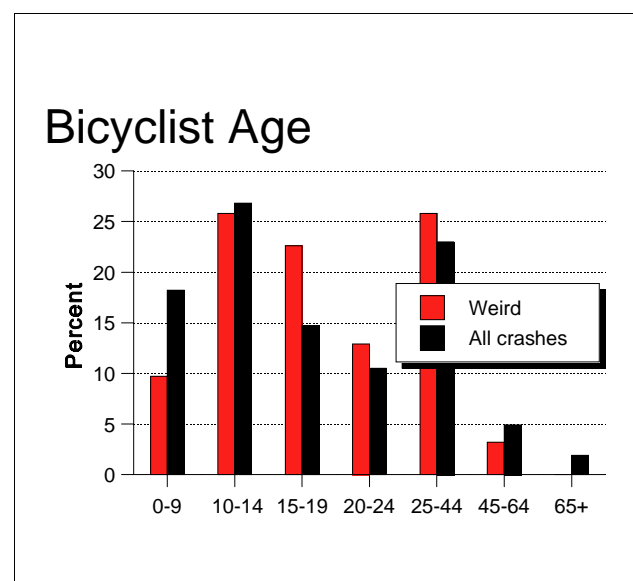
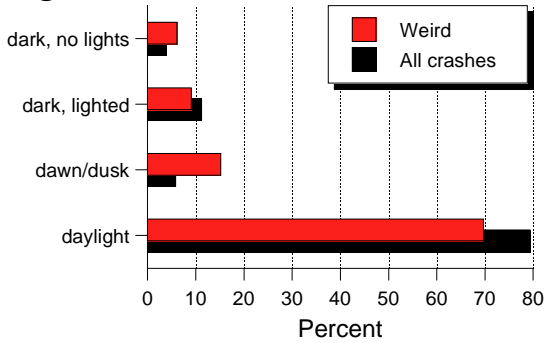
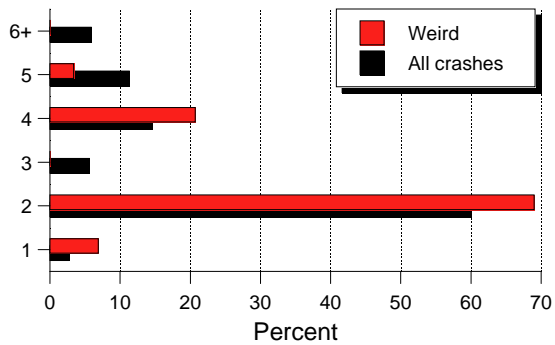

Figure 103. Bicyclist age in "Weird."

Light Condition



Number of Lanes



Speed Limit (km/h)

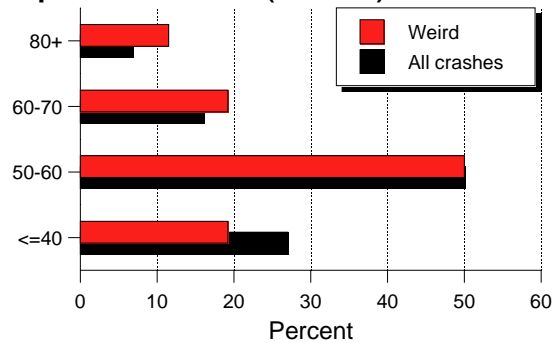

Development Character

- ▶ Urban 66%
- ▶ Rural 34%

Traffic Control

- ▶ None 85%
- ▶ Traffic Signal 9%
- ▶ Stop Sign 6%

Road Feature

- ▶ No special feature .. 59%
- ▶ Driveway 24%
- ▶ Intersection 18%

Figure 104. Light condition, number of lanes, and speed limit in “Weird.”

Motorist Overtaking—Other

Frequency: 117 cases; 3.9% of all crashes
Severity: 28% resulted in serious or fatal injuries

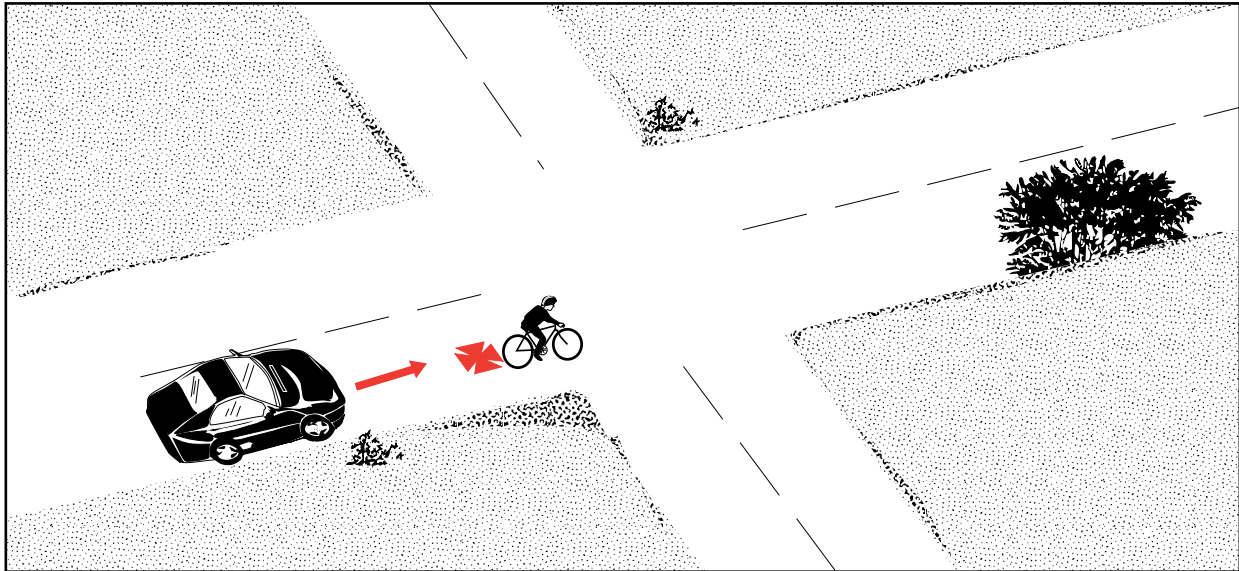

Description: The motorist was overtaking a bicyclist and the circumstances could not be specified.

Summary: In comparison to all crashes, this crash was more likely to involve young adult (age 20 to 24), adult (age 25 to 44) and middle adult (age 45 to 64) bicyclists, take place at night, and occur on very high-speed (80+ km/h) roads. Almost 40 percent occurred during darkness.

While the large majority occurred at midblock, 15 percent occurred at or near an intersection. Twelve percent of bicyclists were on the shoulder and 3 percent were in a bike lane. Nine percent were on a curve.

Sixteen percent of adult bicyclists age 25 and older and 6 percent of motorists had been drinking.

Forty-one percent were hit & run. Injury severity was worse than the average of all crashes.

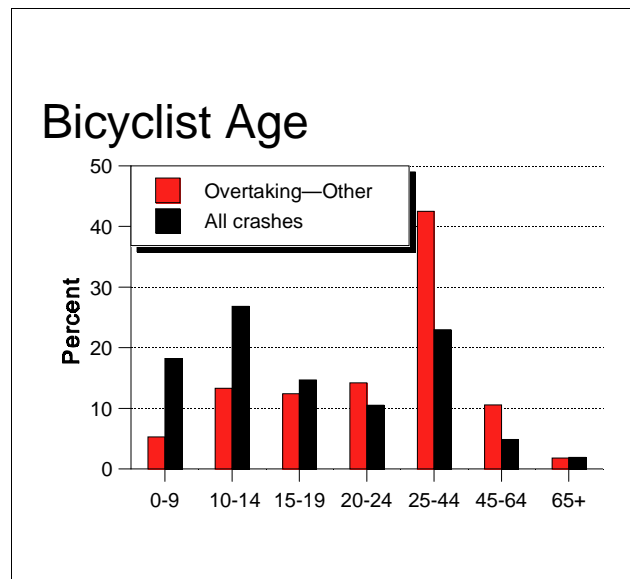
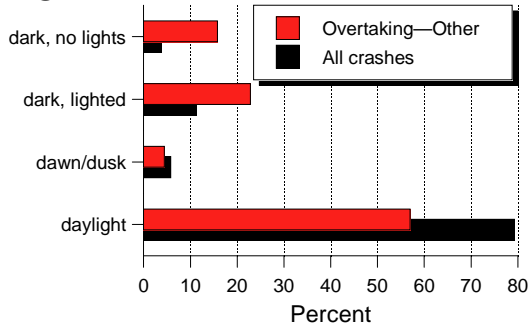

Figure 36. Bicyclist age in “Motorist Overtaking—Other.”

Motorist Overtaking—Other

Light Condition



Number of Lanes

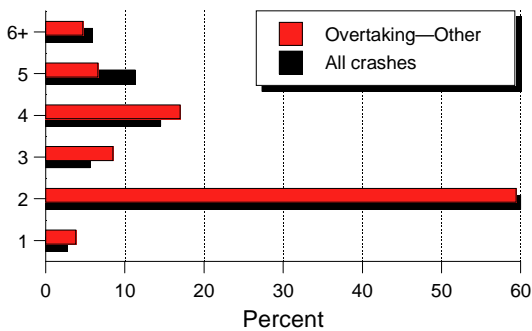

Speed Limit

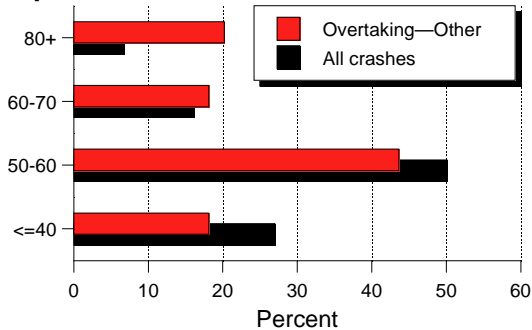

Figure 37. Light condition, number of lanes, and speed limit in “Motorist Overtaking—Other.”

Development Character

- ▶ Urban 57%
- ▶ Rural 43%

Road Feature

- ▶ No special feature . . . 77%
- ▶ Intersection 15%
- ▶ Driveway 3%
- ▶ Other 4%

Positions

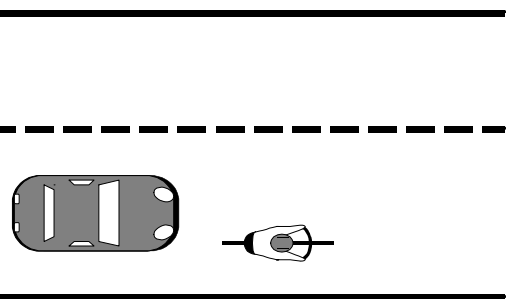

15% of bicyclists were on the shoulder or in a bike lane.

Figure 38. Positions in “Motorist Overtaking—Other.”

Play Vehicle

Frequency: 16 cases; 0.5% of all crashes
Severity: 28% resulted in serious or fatal injuries

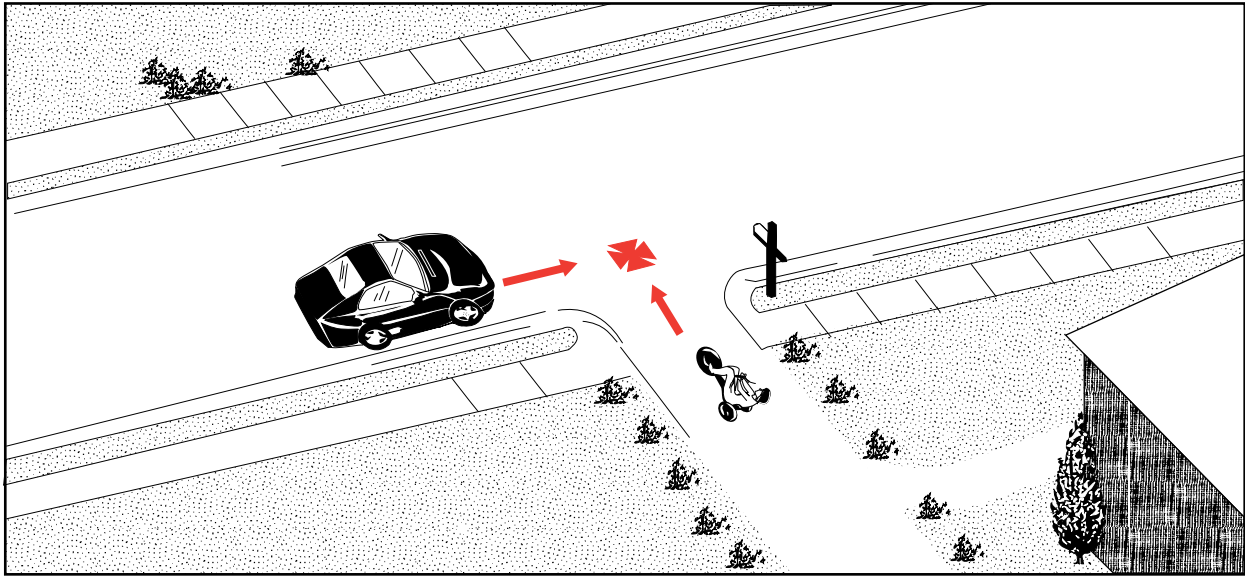

Description: The bicyclist was riding a child's vehicle such as a tricycle, a "Big Wheel" type tricycle, or a bicycle with training wheels.

Summary: This crash involved 100 percent child (age 0 to 9) bicyclists, daylight conditions, and two-lane roads (for those crashes that were roadway-related).

Sixty-three percent occurred on the roadway and 37 percent were non-roadway. Forty-four percent of motor vehicles were backing.

This crash tended to be more severe than the average.

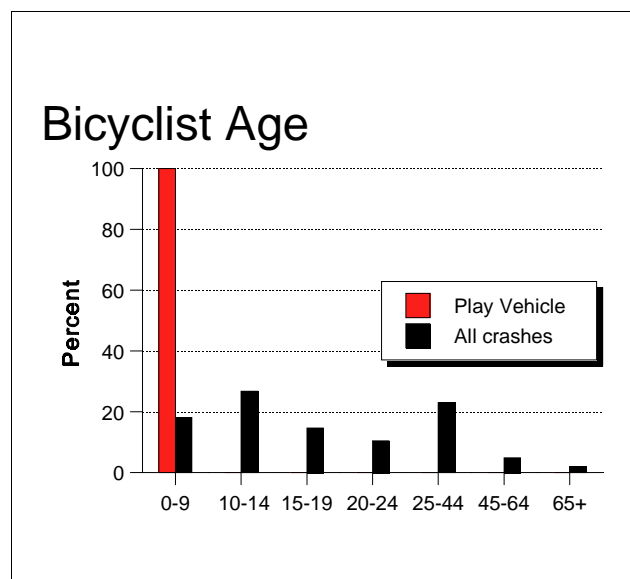
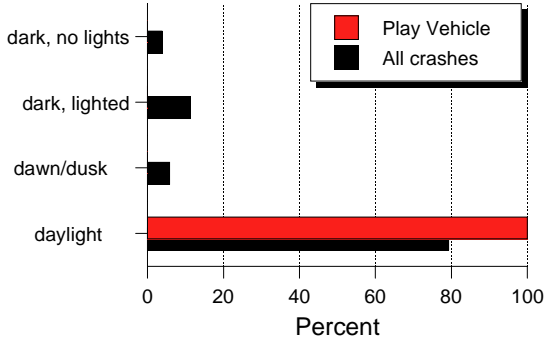

Figure 105. Bicyclist age in "Play Vehicle."

Play Vehicle

Light Condition



Number of Lanes

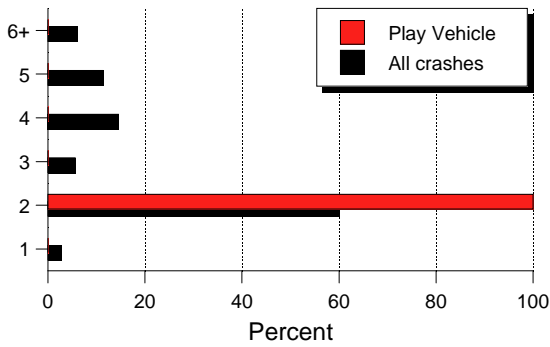

Speed Limit (km/h)

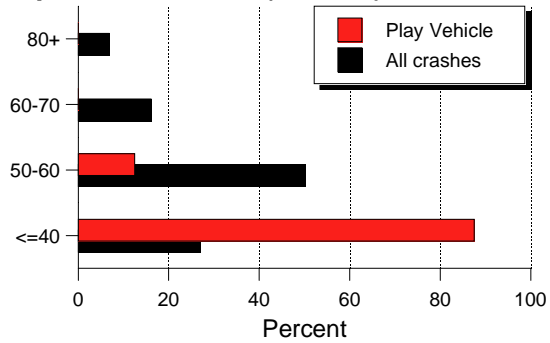

Figure 106. Light condition, number of lanes, and speed limit in “Play Vehicle.”

Development Character

- ▶ Urban 67%
- ▶ Rural 33%

Location

- ▶ Roadway 63%
- ▶ Non-roadway 37%

Road Feature

- ▶ Driveway/Alley ... 60%
- ▶ No special feature .. 30%
- ▶ Intersection 10%

Example Positions

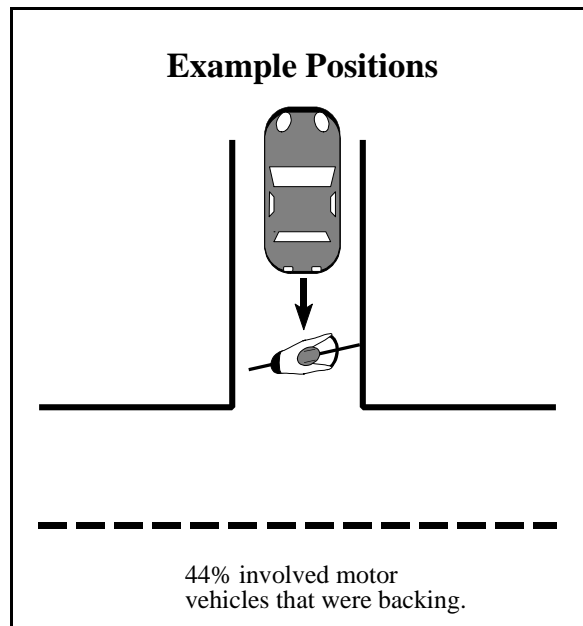
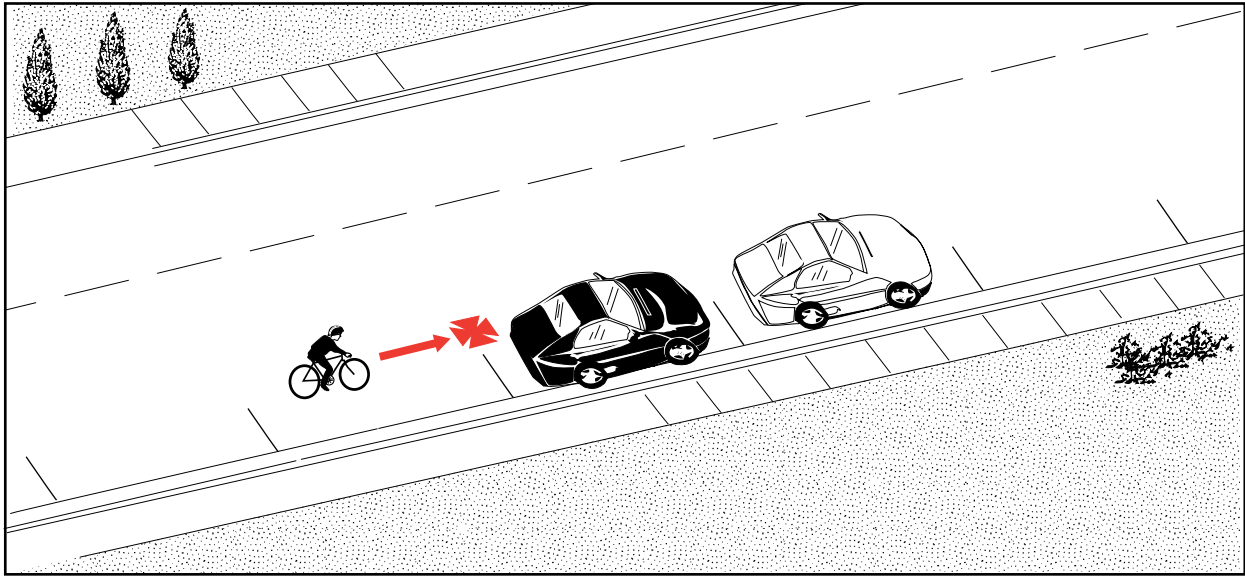

Figure 107. Positions in “Play Vehicle.”

Bicyclist Strikes Parked Vehicle

Frequency: 43 cases; 1.4% of all crashes
Severity: 10% resulted in serious or fatal injuries



Description: The bicyclist struck a motor vehicle parked within the roadway right-of-way.

Summary: In comparison to all crashes, this crash was more likely to involve young adult (age 20 to 24) and adult (age 25 to 44) bicyclists. Almost 90 percent occurred in urban areas.

The motor vehicle was in a marked parking lane in 19 percent of the crashes, an unmarked parking “lane” 64 percent, on the shoulder 7 percent, in a bike lane 9 percent, and in the travel lane 1 percent.

Some type of road/environmental contributing factor such as weather, vision obstruction, glare, etc. was noted in 39 percent of these events.

These crashes tended to be less severe than the average. There were no fatalities.

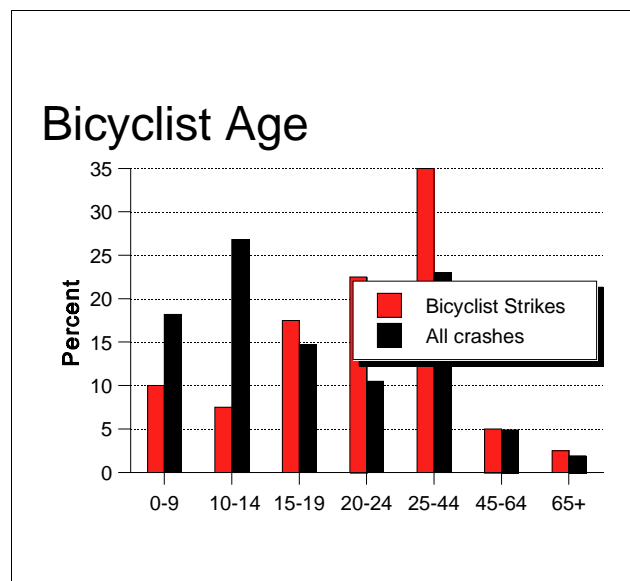
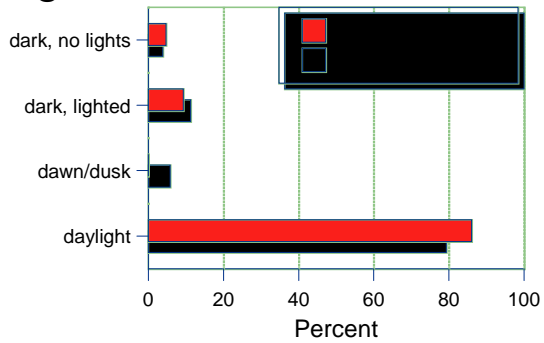

Figure 42. Bicyclist age in “Bicyclist Strikes Parked Vehicle.”

Bicyclist Strikes Parked Vehicle

Light Condition



Number of Lanes

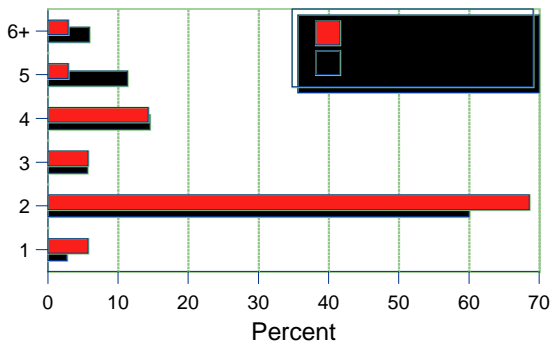

Speed Limit (km/h)

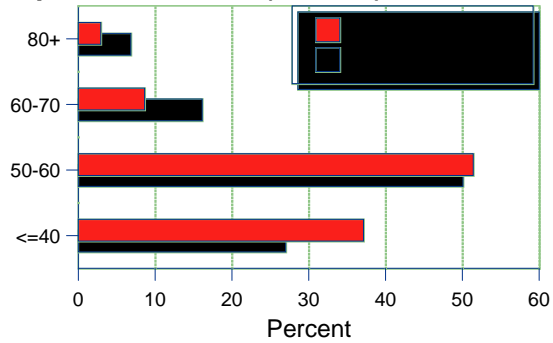

Figure 43. Light condition, number of lanes, and speed limit in “Bicyclist Strikes Parked Vehicle.”

Development Character

- ▶ Urban 86%
- ▶ Rural 14%

Positions

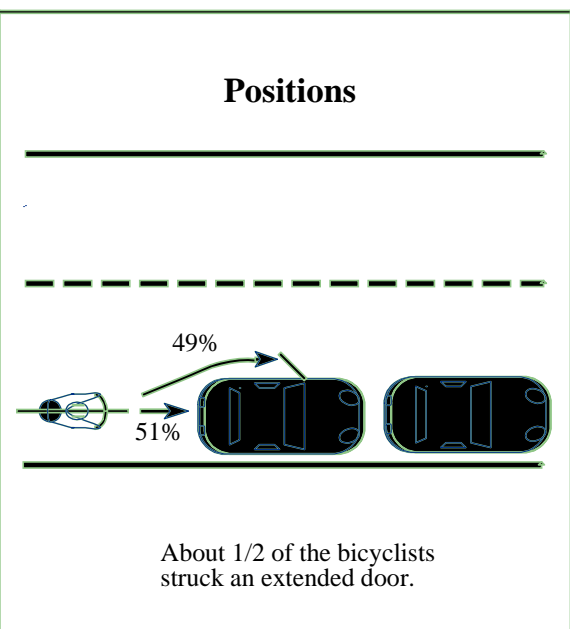
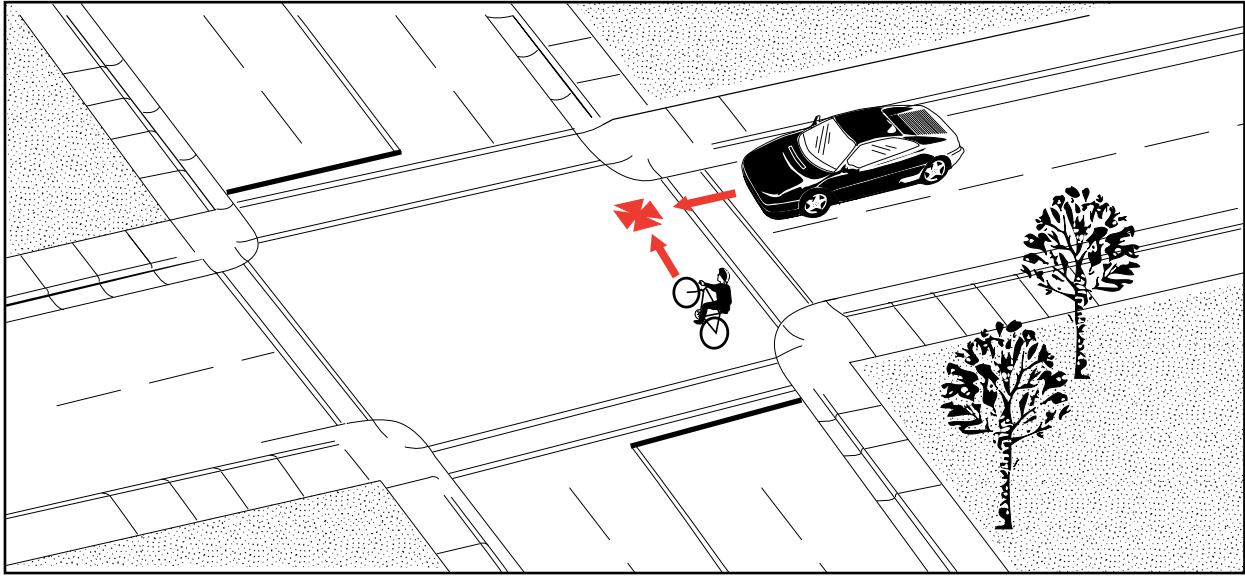

Figure 44. Positions in “Bicyclist Strikes Parked Vehicle.”

Drive Out At Intersection—Other

Frequency: 16 cases; 0.5% of all crashes
Severity: 9% resulted in serious or fatal injuries



Description: The crash occurred at an intersection, signalized or uncontrolled, at which the motorist failed to yield. The circumstances did not conform to any other crash type.

Summary: In comparison to all crashes, this crash was more likely to involve adult (age 25 to 44) and middle adult (age 45 to 64) bicyclists.

Four and five-lane roads were heavily represented, combined accounting for 70 percent of crashes.

All of these crashes occurred on roads with a speed limit of 50 to 60 or 60 to 70 km/h.

This type of crash tended to be less severe than the average. There were no fatalities.

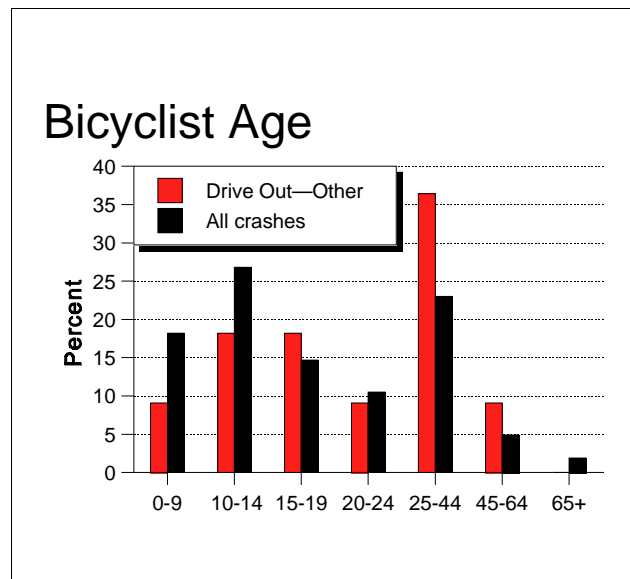
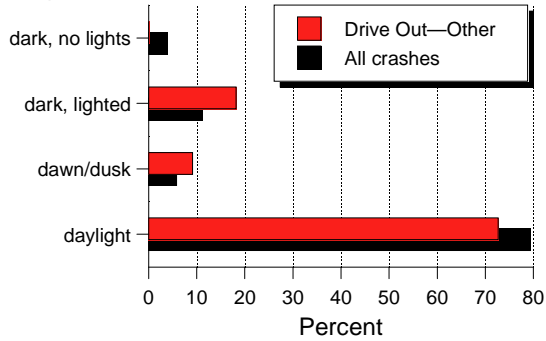

Figure 71. Bicyclist age in “Drive Out At Intersection—Other.”

Drive Out At Intersection—Other

Light Condition



Number of Lanes

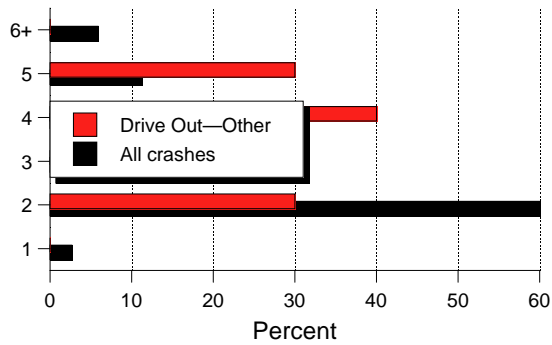

Speed Limit (km/h)

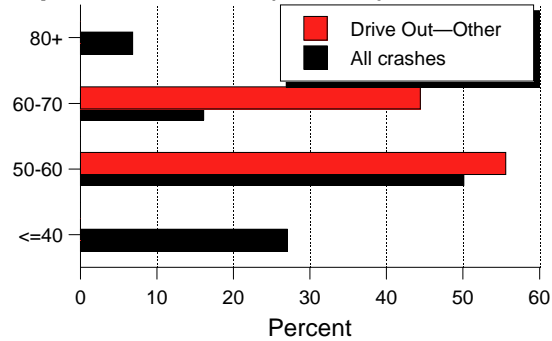

Figure 72. Light condition, number of lanes, and speed limit in “Drive Out At Intersection—Other.”

Development Character

- ▶ Urban 64%
- ▶ Rural 36%

Traffic Control

- ▶ None 82%
- ▶ Traffic Signal 9%
- ▶ Other 9%

Positions

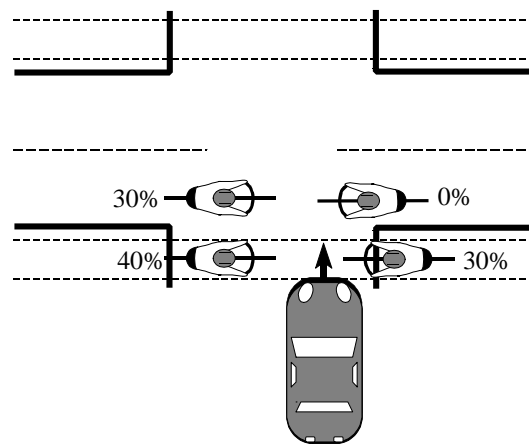

Most of the bicyclists were in the “off road” position.

Figure 73. Positions in “Drive Out At Intersection—Other.”

Ride Out At Intersection—Other

Frequency: 211 cases; 7.1% of all crashes
Severity: 16% resulted in serious or fatal injuries

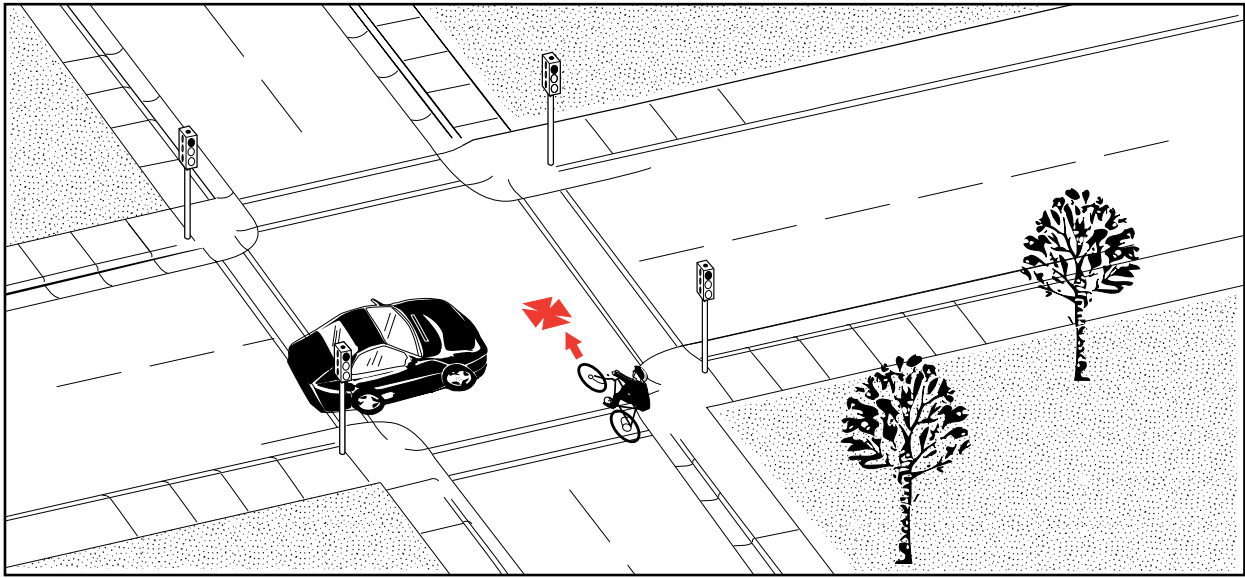

Description: The crash occurred at an intersection, signalized or uncontrolled, at which the bicyclist failed to yield.

Summary: In comparison to all crashes, this crash was more likely to involve child (age 0 to 9) and youth (age 10 to 14) bicyclists.

Almost 50 percent took place on multilane roads (4, 5, and 6+ lanes).

A traffic signal was present in about 60 percent of the crashes.

More than 60 percent of the bicyclists were struck in their first half of the roadway.

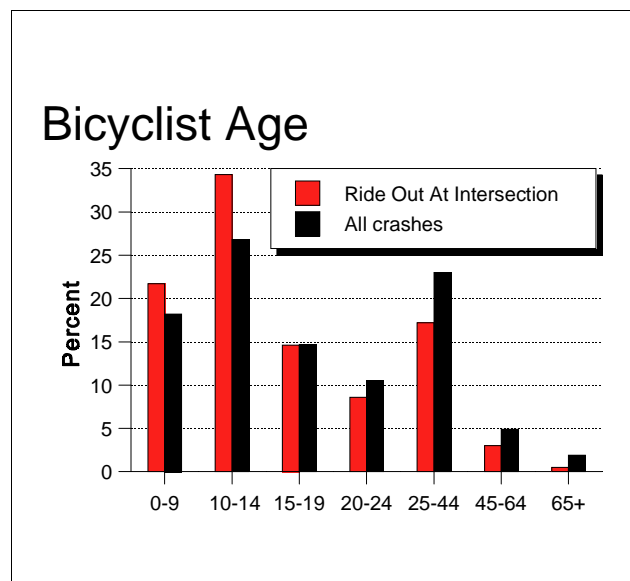
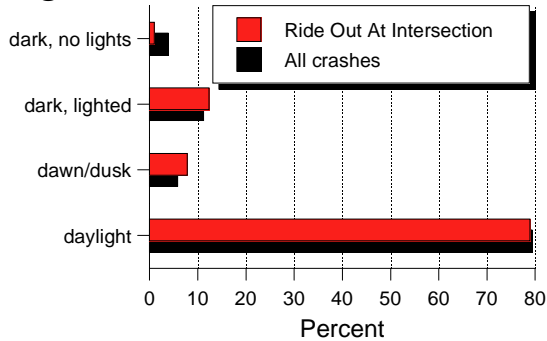

Figure 87. Bicyclist age in “Ride Out At Intersection—Other.”

Ride Out At Intersection—Other

Light Condition



Number of Lanes

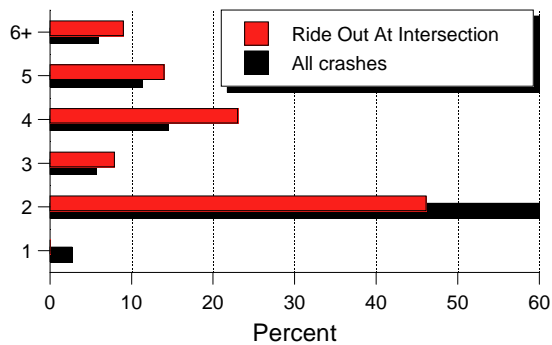

Speed Limit (km/h)

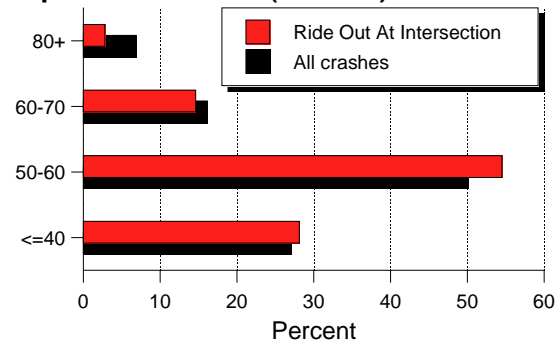

Figure 88. Light condition, number of lanes, and speed limit in “Ride Out At Intersection—Other.”

Development Character

- ▶ Urban 67%
- ▶ Rural 33%

Traffic Control

- ▶ Traffic Signal 58%
- ▶ None 36%
- ▶ Other 6%

First-half of Roadway Positions

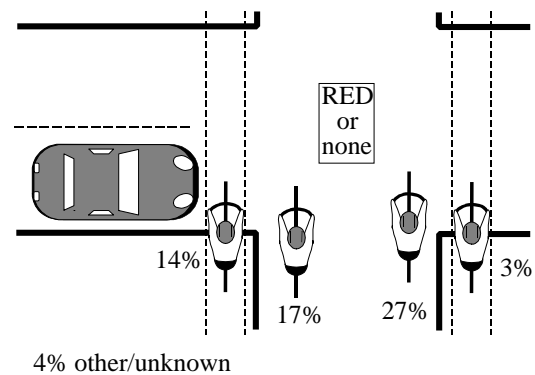

65% of the bicyclists were struck in their first-half of the roadway.

Figure 89. First-half positions in “Ride Out At Intersection—Other.”

Second-half of Roadway Positions

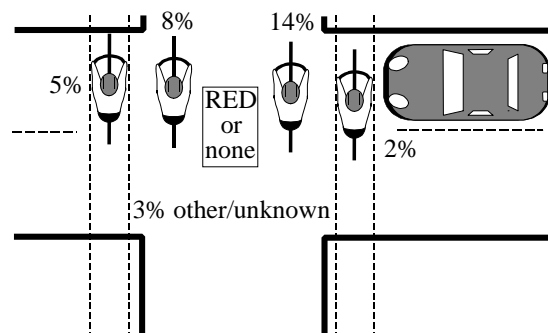

32% of the bicyclists were struck in their second-half of the roadway. 3% were unknown first or second half.

Figure 90. Second-half positions in “Ride Out At Intersection—Other.”

Controlled Intersection—Other

Frequency: 63 cases; 2.1% of all crashes
Severity: 16% resulted in serious injuries

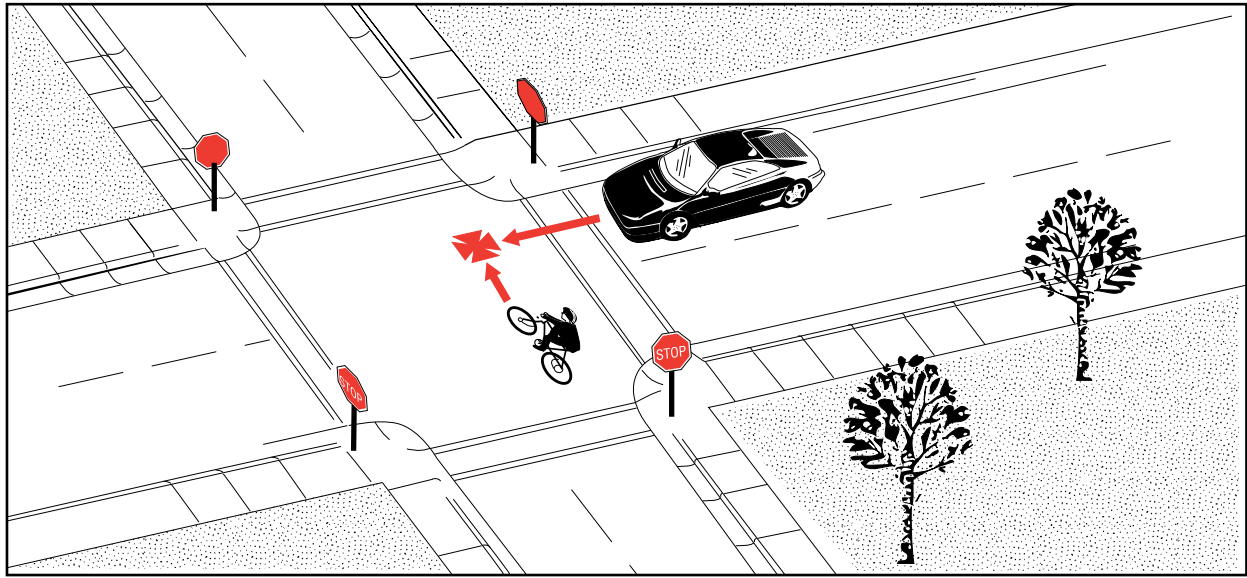

Description: The crash occurred at an intersection that was controlled by stop sign or traffic signal, and did conform to any of the other crash types.

This crash was about average in severity. There were no fatalities.

Summary: The bicyclist age distribution for this crash generally followed the pattern for all crashes combined. Compared to all crashes, multilane roads (4, 5, and 6+ lanes) and roads with a speed limit of 50 to 60 and 60 to 70 km/h were more likely to be involved.

More than 8 out of 10 occurred in urban areas.

The traffic control was approximately equally split between traffic signal and stop sign. Bicyclists were riding in a marked crosswalk in 24 percent of these crashes. A marked crosswalk was involved in only 7 percent of all crashes combined.

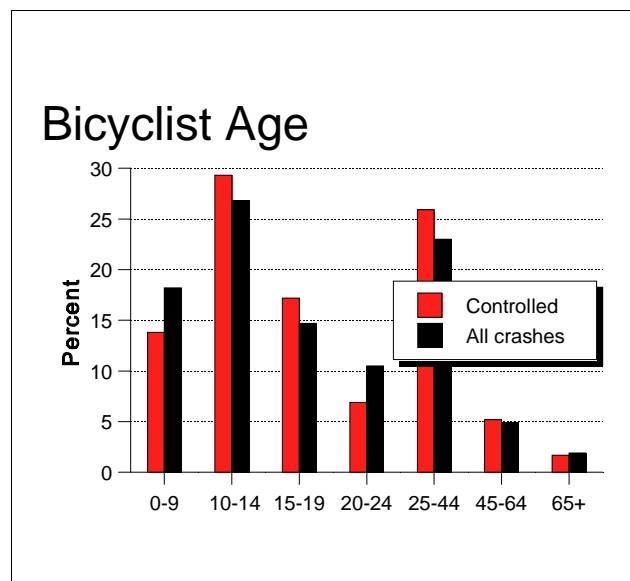
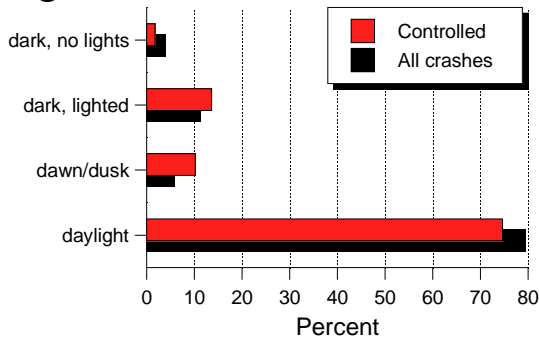

Figure 97. Bicyclist age in “Controlled Intersection—Other.”

Controlled Intersection—Other

Light Condition



Number of Lanes

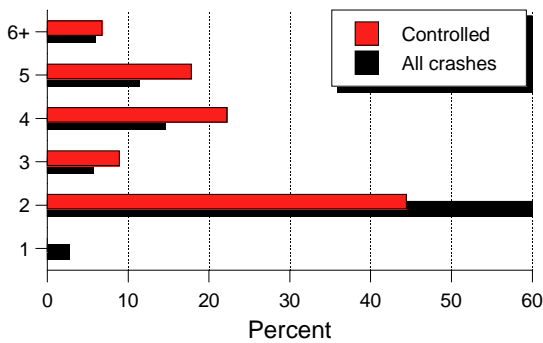

Speed Limit (km/h)

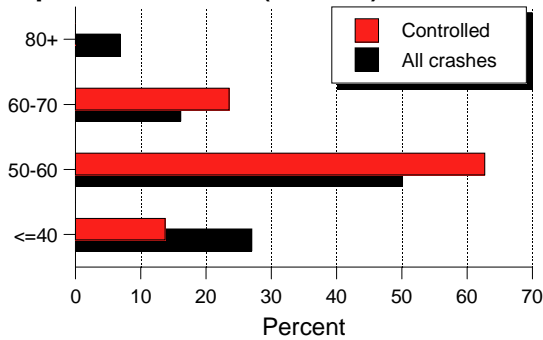

Figure 98. Light condition, number of lanes, and speed limit in “Controlled Intersection—Other.”

Development Character

- ▶ Urban 82%
- ▶ Rural 18%

Traffic Control

- ▶ Traffic Signal 46%
- ▶ Stop Sign 40%
- ▶ Other 14%

Positions

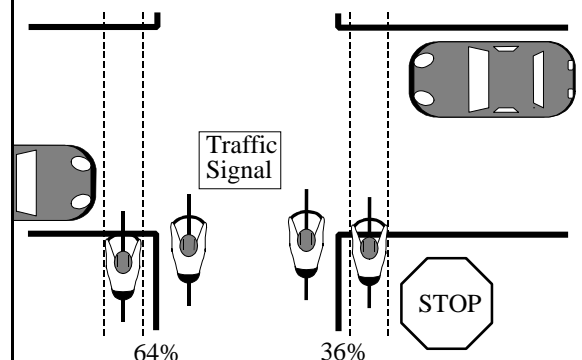

About 2/3 of the bicyclists were riding facing traffic. Specific locations are unknown.
 Note: The motorist may have had the stop sign.

Figure 99. Positions in “Controlled Intersection—Other.”