

CHAPTER IV

LEAK DETECTION

This chapter contains a simplified description of the leak detection requirements contained in the pipeline safety regulations. The complete text section 192.723 can be found in 49 CFR Part 192.

METHODS OF DETECTING A LEAK

1. Odor. Gas is intentionally odorized so that the average person can perceive it at a concentration well below the explosive range. That odorant concentration is generally between 0.5 to 1.0 percent by volume or as local applicable codes dictate. Gas odor is a common and effective indication of a leak. **A report of gas odor should be investigated immediately.** If a leak is found, the migration pattern of the gas should be determined. If an immediate hazard is determined to exist, the hazard potential should be eliminated and the leak repaired immediately. Appendix 11 of the Gas Piping Technology Committee's "Guide for Gas Transmission and Distribution Piping Systems" (published by the American Gas Association), contains detailed information on leak classification and action criteria. The odor of gas may be filtered out as the odorized gas passes through certain types of soil. It may also be modified by passing through soil and into a sewer system containing vapors or fumes from other combustibles as well as the sewer odor itself. Therefore, odor is not always totally reliable as an indicator of the presence or absence of gas leaks. For this reason all gas leak reports should be investigated using a leak detection instrument such as a Combustible Gas Indicator (CGI) or a Flame Ionization Detector (FI). Gas personnel should remember that the primary purpose of the gas odor is to provide a warning to the public, who do not have gas detection instruments.
2. Vegetation. Vegetation in an area of gas leakage may improve or deteriorate, depending on the soil, the type of vegetation, the environment, the climate, and the volume and duration of the leak. Changes in vegetation may indicate slow below ground leaks. A vegetation survey by itself is not an acceptable method of complying with the pipeline safety regulations (see 49 CFR §192.723). Leak surveys should be conducted with leak detection equipment.
3. Insects (flies, roaches, spiders). Insects migrate to points or areas of leakage due to microbial breakdown of some components of gas. Some insects like the smell of the gas odorant. Heavy insect activity, particularly near the riser, the gas meter, or the regulator, can sometimes indicate a gas leak.
4. Fungus-like Growth. Such growth in valve boxes, manholes, etc., may indicate gas leakage. These fungi grow best where there is a lack of oxygen, such as in a gas leak area. The color of the growth is generally white or grayish-white similar to a coating of frost. All such indications should be investigated with a leak detection instrument. Personnel should never enter manholes or other confined spaces without first testing oxygen levels and gas concentrations. Check Occupational Safety and Health Administration (OSHA) regulations concerning confined space entry for further details on this subject.

5. Sound. Listen for leaks. A hissing sound at a bad connection, a fractured pipe, or a corrosion pit is the usual indication of a gas leak. Using a soap solution directly on the pipe or fitting will indicate the presence of a leak. If a strong gas odor is in the air, care should be taken to turn on and zero gas detection equipment away from the area where the odor is present.
6. Unaccounted for Gas. A possible leak is indicated when an off-peak reading of a master meter with a known average seasonal utilization rate, shows unaccountably high usages rate. Periodic off-peak checks (preferably in the summer months from midnight to 3 or 4 a.m.) can be averaged to provide data for comparison in future checks. This method may indicate a leak on the system, but will not provide a location for the leak. It is also most effective if consumption figures are known for a time period before the leak(s) occurred. A comparison of bills from the gas supplier showing gas consumption may also indicate leakage on the system. This procedure is also most effective when comparing consumption during summer months over a period of several years. If excess consumption is suspected, the system should be leak surveyed using gas detection equipment.

Gas leaks in residential areas (served by a master meter as well as by customer meters) can be detected by comparing the total consumption registered on the customer meters with that registered on the master meter. If the master meter reading is greater than that recorded by adding all the unit meter readings, then a leak probably exists in the distribution system. This condition may also indicate gas theft or a malfunctioning meter problem. If this method is used, the individual or customer meters should be read on the same day as the master meter. This will allow a more accurate comparison of gas volumes.

For a municipal system, an unexpected increase in the amount of natural gas purchased from the transmission company for a given month, as compared to past gas consumption for the same month, may indicate a leak in the system. The operator is cautioned that changes in load factors and weather must be considered when using this method. The operator should be sure to compare similar time periods, as a change in the meter reading cycle will affect this process. Dividing the gas purchased by the number of days in the billing cycle will give an average per day consumption, which would be more accurate to use in comparing bills. Low load periods such as the summer months would provide the best data.

7. Soap Solutions. A soap solution can pinpoint the location of a leak on an exposed pipe, on the riser, or on the meter. The solution is brushed or sprayed on and the location of bubbling indicates leakage. When excavating underground piping to investigate a suspected leak location, the pipe should be brushed clean and completely expose the top, sides and bottom. Many leaks are found on the bottom of the pipe. A mirror may be used to observe the underside of the pipe. NOTE: It is recommended that a soap solution specifically designed for pipelines be used.
8. Leak Detection Instruments. Gas leak indicators are sophisticated instruments that require regular care, maintenance, and calibration, and should be used by trained personnel. Two types are commonly used by the gas industry for surveying and pinpointing leaks:
 - Combustible gas indicator (CGI),

- Flame ionization (FI) gas detector.

A third type of instrument, called a bead sensor type detector, is most often used for inspecting exposed piping and appliances to pinpoint leaks on those facilities. Bead sensor instruments are not generally used for leak surveys of underground piping.

DESCRIPTION OF LEAK DETECTION EQUIPMENT

Combustible gas indicator. The CGI (FIGURE IV-3) consists of a meter, a probe, and an aspirator bulb. The bulb is pumped by hand to bring a sample of air into the probe and the instrument. The dial on the instrument indicates the percentage of flammable gas in air (percent gas scale) or percent of the lower explosive limit (LEL) scale. These instruments must be calibrated for the type of gas in the system. The CGI should be calibrated for natural gas for use on a natural gas system.

FIGURE IV-3

These are pictures of CGIs. RSPA recommends that a two-scale meter be purchased (LEL and percent gas).



FIGURE IV-3A

Example of today's new CGI technology, which is motor driven and gives digital readouts.

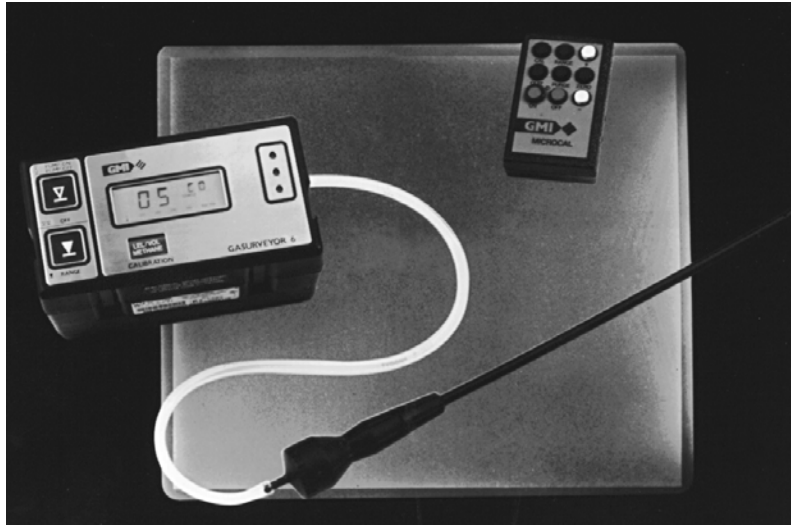
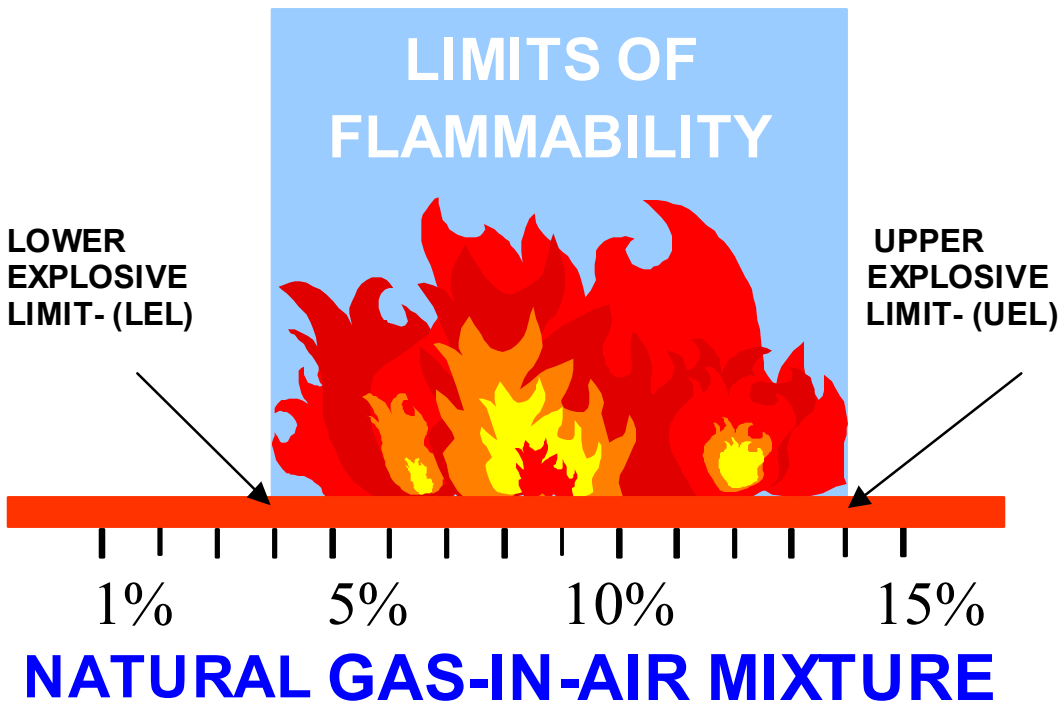

FIGURE IV-4



This is an illustration of the lower and upper explosive limits for natural gas. Typical natural gas is flammable in 4 to 14 percent natural gas in air mixture. In a confined space, a 4 to 14 percent mixture can be explosive.

The CGI is not suitable for above ground surveys. The CGI was designed primarily for use in a confined space. Its two main applications for outside surveys are termed "available openings" and "bar holing." A bar hole is a small diameter hole made in the ground in the vicinity of gas piping to extract a sample of the ground atmosphere for leak analysis. NOTE: Use extra caution when bar holing in the area of polyethylene pipe.

The CGI instruments are also useful in building surveys and in areas within a building, such as heater closets, and other confined areas. The bead sensor unit is also used in these locations. However, it does not give readings in percent of gas or percent of LEL, and must not be used for determining if a hazard exists. A CGI should always be used first when entering a building to determine if a hazardous atmosphere is present. Once the atmosphere has been determined to be non-hazardous (no LEL or gas readings), a bead sensor may be used for an inside leak survey.

One person can operate the CGI. Leak location is accurate and minimal training is necessary to use the instrument. The cost of a CGI is substantially lower than an FI unit.

The Flame Ionization (FI) detector uses a hydrogen fuel to power a small flame in a detector cell. A pump or venturi system is used to pass continuous air samples through the detector cell. If the air contains hydrocarbons such as natural gas, they will be burned or ionized in the hydrogen flame. This is detected electronically and displayed on a meter readout. FI units are equipped with meters that indicate gas concentrations from 1 part per million (PPM) to 10,000 PPM (which is the same as one-percent gas in air). They are also equipped with audible alarms to alert the operator when there is a meter deflection.

Leak survey can be done more rapidly with an FI unit than with a CGI using the bar hole method. FI units can be carried by hand for a walking survey or mounted on a vehicle for a mobile survey. Any gas indications detected by the FI should be confirmed using a combustible gas indicator. Leak pinpointing is also done with a CGI.

Leak survey technicians must be trained and qualified in the operation of the FI and CGI. Additional training is required on leak survey procedures, leak classification, recognition of hazards and pinpointing. All gas personnel should also receive training on "make safe" actions. Gas operators are not required to own FI equipment or to conduct their own leak surveys. They may choose to hire a leak survey consultant to conduct inspections. Consultants should also be trained in these topics and are required to be in a drug and alcohol-testing program, the same as gas personnel.

FIGURE IV-5
A picture of a FI unit.



FIGURE IV-6



This man is checking a gas meter for leaks with a hand-carried FI unit.

RECOMMENDED METHOD FOR SURFACE GAS DETECTION SURVEY WITH FI UNIT (NATURAL GAS SYSTEM ONLY)

The ability of the gas to vent at the ground surface is critical for the success of a surface survey with an FI unit (FI is not to be used when the ground is frozen). A continuous sampling of the atmosphere at buried main and services should be made at ground level or at no more than 2 inches above the ground surface. In areas where the gas piping is under pavement, samplings should also be at curb line(s), available ground surface openings (such as manholes, catch basins, sewers, power, telephone duct openings, fire and traffic signal boxes, or cracks in the pavement or sidewalk), or other interfaces where the venting of gas is likely to occur. For exposed piping, sampling should be adjacent to the piping.

In wet, frozen, or windy conditions the gas may be restricted from venting or be rapidly diluted below FI detection levels. One method to determine if conditions are appropriate for leak survey is to re-survey a known small leak on the system. If it can be detected at normal walking or driving speeds, the survey can continue.

FIGURE IV-7

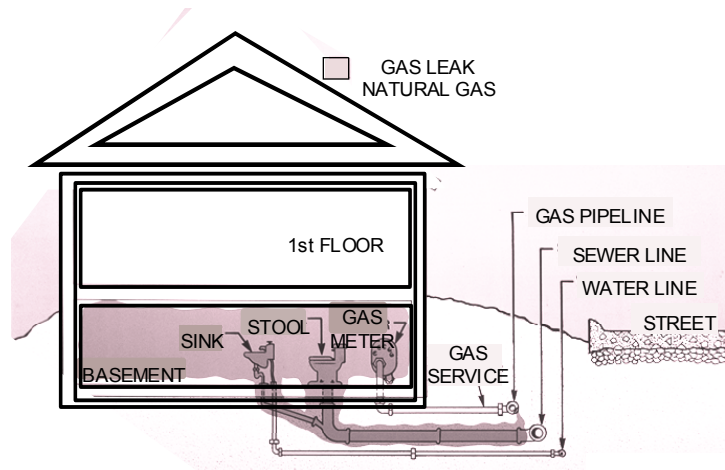

This figure shows leaking gas following the sewer line into the home, after leaking at the service tee. Natural gas can migrate in this manner.

FIGURE IV-8

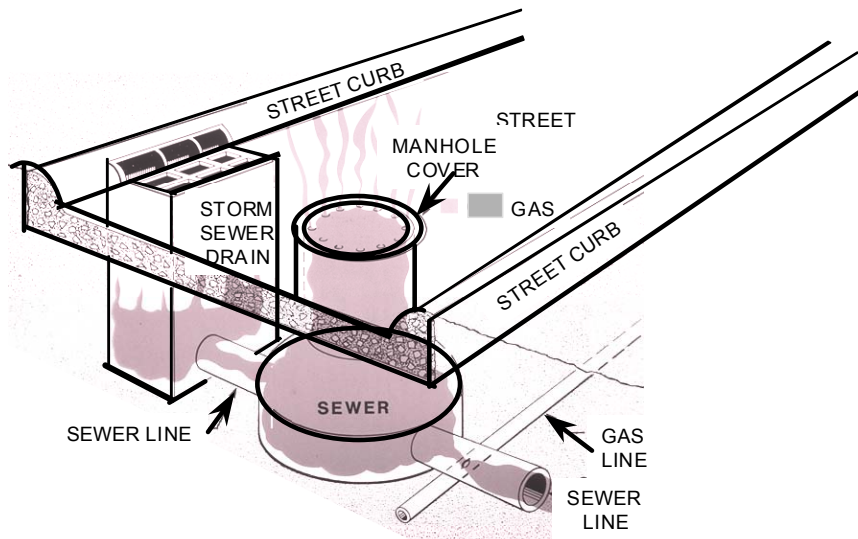

This is an example of how a gas leak can get into a sewer system. This is why it is essential when conducting a leakage survey to check all available openings, including manholes, sewers, vaults, etc. Any indication of gas in a confined space or in a building should be considered a hazardous situation. Persons should be removed from the area, and ignition sources eliminated. Once this is done, the leak investigation should begin, and the leak repaired when found. The facilities affected should be monitored, and the gas migration pattern determined. Gas should be vented from the soil and structure before allowing persons to return to the area.

ODORIZATION EQUIPMENT

This chapter provides information for natural gas system operators who odorize their own gas. All of the equipment and illustrations refer to natural gas systems.

The following are some illustrations and brief discussions of odorization equipment used by operators of small natural gas systems.

FIGURE IV-9

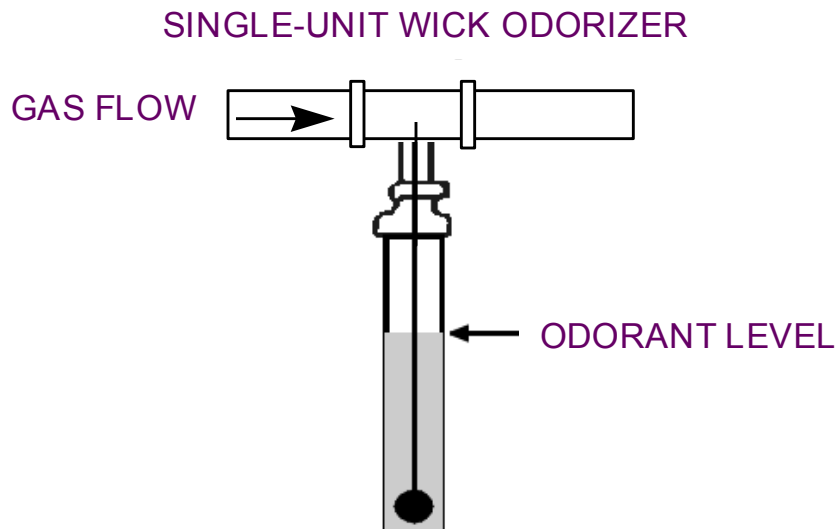

The figure shows equipment which odorizes the gas by having natural gas flow across a wick saturated with odorant (generally used for individually odorized lines such as farm taps).

NOTE: Pitot tube version eliminates wick and lessens summer problems with odorization process.

FIGURE IV-10

Equipment in which a portion of the main gas stream is diverted, by an orifice plate or partially closed valve in the line, through a tank provided with baffles or wicking. The odorant-saturated portion of the bypass gas is then returned to the main stream. Generally used for low, more uniform flows.

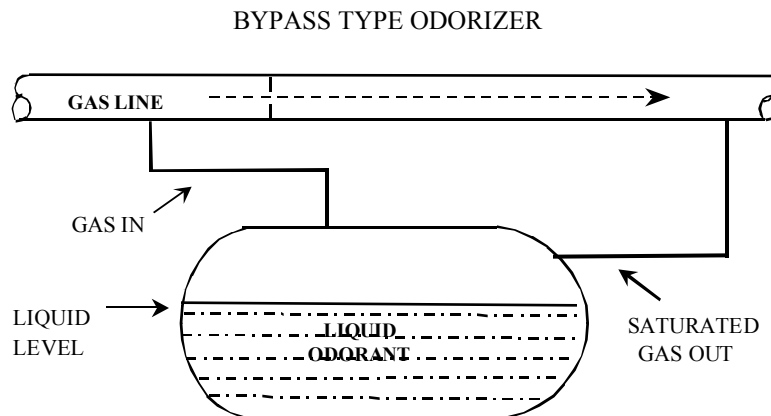

Odorization equipment may need seasonal adjustments. Valves that regulate the amount of gas diverted into the odorizer need to be adjusted between seasons of high flow and low flow of gas (winter vs. summer). Based on the equipment manufacturer's recommendation, operational instructions for specific systems can be developed. These instructions should be included in the operations and maintenance plan.

Equipment Selection Considerations

Selection of the appropriate odorant and odorizing equipment may require professional advice. Operators should consult with an odorant and/or equipment supplier who can help guide odorant selection. These persons can evaluate an operator's unique pipeline situation and advise on the best odorant and the best equipment. Operators are encouraged to consult with more than one of these organizations to obtain the best odorant and equipment for the best price.

Types of Odorants

Most odorants used in the United States are mercaptans or mercaptan sulfide blends, both of which contain tertiary butyl mercaptans as their main component. The only other odorant in wide use is cyclic sulfide (thiophane), which is mainly used in gas systems containing natural odorants. It is also used in farm tap odorizers.

The human sense of smell is very discerning and can detect mercaptans at a concentration of only 1 part per billion (ppb), which is currently beyond the capabilities of most instruments. The sulfur content of the odorants in the gas stream can be measured by gas analysis, which may then be used to determine if there is sufficient odorant.

The main types of detectors are odor concentration meters, titrators, and gas chromatographs dedicated to sulphur analysis. Of these instruments, the most common is the odor concentration meter. The pipeline safety regulations require operators to odorize a combustible gas in a distribution pipeline. The operator is referred to 49 CFR §192.625 for the existing requirements regarding odorization of gas.

Discussion of Odor Testing Instruments

Odor testing instruments are used to determine the lowest concentration at which gas can be detected through odor (see FIGURE IV-11). The unit is actually a measuring device that indicates the percent of gas by volume in a sample when an odor is detected. To determine the odor threshold level, the unit is used in an area where it can draw in fresh air and be connected to a gas source. A blower in the unit draws ambient air through the analyzer and out the exhaust chamber. The procedure for running a test is as follows: After the instrument is connected to gas and running, quickly open the gas valve fully to make certain that gas is entering the instrument and then shut the valve quickly. Wait for any odor to dissipate and then proceed with the test. With just air coming from the exhaust port, inhale or "sniff" at the opening. There are two important points to remember when running a test. First, put the nose as close to the opening as possible (see FIGURE IV-12), as this is the location at which the instrument is calibrated. If the operator does not put his or her nose close to the opening, the sample will be diluted by surrounding air and not representative of the percent gas shown by the odor testing instrument. Second, after sniffing at the opening, immediately withdraw the nose to fresh air and take a breath. If the nose is left at the opening, the mercaptan odor will temporarily deaden the operator's sense of smell.

To repeat, take a sniff or two of only air at the opening, getting a breath of fresh air between sniffs, and become familiar with the smell of the air coming from the instrument. The operator does this because each instrument has its own unique background odor. After a couple of sniffs of air at the opening, slowly open the gas valve and sniff. Continue to open and sniff, getting a breath of fresh air between sniffs. Repeat this procedure until a change in odor can be detected. At that point record the percentage of gas and mark it "threshold." Threshold, as used here, is the minimum concentration of a gas in air at which one can detect a change in odor. The odor cannot be readily identified at that concentration, but a change in odor is barely detectable. Do not shut the valve but continue to open and sniff (getting a fresh breath in between, and remembering to put the nose as close as possible) until there is a sufficient odor for the operator to decide that the odor is a readily detectable gas odor. Record that reading and mark it "readily detectable." Turn off the gas valve at this point.

Do not skip the threshold part of the test. This part of the test is very important because it slows the operator's decision process and prevents him from making a premature decision. Manufacturers recommend that odor testing instruments be recalibrated on an annual basis, and are currently offering to update old instruments.

Monitoring Techniques

- Operators of master meter or small natural gas systems should periodically verify the odor level with the gas company or have a consultant run an odor test using some type of odor testing instrument on the gas in the system to determine if it is properly odorized. The best time would be when there is a low usage of gas by customers. Operators should check with their respective state regulatory agencies to see whether there are additional requirements.
- Operators should include as an operating procedure the requirement that "sniff tests" be made whenever a meter set, repair to system, or leak check is made. A sniff test is when one or more observers smell gas from an open valve, or gas burner. The name of the person, the date, and location of the test must be kept on file.
- Operators should make a sniff test at extremities of the system at least once a month.

FIGURE IV-11

A picture of an odor testing instrument.



FIGURE IV-12

This man is conducting a sniff test using an odor testing instrument.



RECORDS

Operators must record all leakage surveys, leaks found, and all repair data. The sample form in Appendix B may be used. Remember that operators can develop their own forms (see APPENDIX B, FORM 2).

Records must include leak reports received from customers or tenants. A sample form for the recording of these leak reports is in APPENDIX B, FORMS 2 AND 3.

GPTC – GUIDE MATERIAL FOR “LEAK CLASSIFICATION AND ACTION CRITERIA”

GPTC has developed guidance material for “Leak Classification and Action Criteria” (see FIGURE IV-13, TABLES 3A, 3B AND 3C).

FOLLOW-UP INSPECTION

The adequacy of leak repairs should be checked before backfilling. The perimeter of the leak area should be checked with a CGI. Where there is residual gas in the ground after the repair of a Class 1 leak, a follow-up inspection should be made as soon as practical after allowing the soil atmosphere to vent and stabilize. OPS suggests follow-up inspection within 24 to 48 hours, but in no case later than 1 month following the repair. In the case of other leak repairs, qualified personnel should determine the need for a follow-up inspection.

A method to remember when investigating gas leaks and determining the classification is to ask, “WHERE is the Gas?” as follows:

- Where is the gas? (Use a detector to confirm gas is present)
- How much is there? (Take readings on the CGI)
- Extent of the spread? (Determine the migration pattern)
- Relation to other structures? (Is gas detected in or near buildings or in manholes?)
- Evaluate/evacuate? (Classify the leak and take appropriate action)

TABLE 3A-LEAK CLASSIFICATION AND ACTION CRITERIA-GRADE 1

GRADE	DEFINITION	ACTION CRITERIA	EXAMPLES
1	A leak that represents an existing or probable hazard to persons or property, and requires immediate repair or continuous action until the conditions are no longer hazardous.	<p>Requires <i>prompt action</i>* to protect life and property, and continuous action until the conditions are no longer hazardous.</p> <p>*The prompt action in some instances may require one or more of the following:</p> <ul style="list-style-type: none"> a. Implementation of company emergency plan (§192.615). b. Evacuating premises. c. Blocking off an area. d. Rerouting traffic. e. Eliminating sources of ignition. f. Venting the area. g. Stopping the flow of gas by closing valves or other means. h. Notifying police and fire departments. 	<ol style="list-style-type: none"> 1. Any leak which, in the judgment of operating personnel at the scene, is regarded as an immediate hazard. 2. Escaping gas that has ignited. 3. Any indication of gas which has migrated into or under a building, or into a tunnel. 4. Any reading at the outside wall of a building, or where gas would likely migrate to an outside wall of a building. 5. Any reading of 80% LEL, or greater, in a confined space. 6. Any reading of 80% LEL, or greater in small substructures (other than gas associated substructures) from which gas would likely migrate to the outside wall of a building. 7. Any leak that can be seen, heard, or felt, and which is in a location that may endanger the general public or property.

TABLE 3B-LEAK CLASSIFICATION AND ACTION CRITERIA-GRADE 2

GRADE	DEFINITION	ACTION CRITERIA	EXAMPLES
2	<p>A leak that is recognized as being non-hazardous at the time of detection, but justifies scheduled repair based on probable future hazard.</p>	<p>Leaks should be repaired or cleared within one calendar year, but no later than 15 months from the date the leak was reported. In determining the repair priority, criteria such as the following should be considered:</p> <ol style="list-style-type: none"> a. Amount and migration of gas. b. Proximity of gas to buildings and subsurface structures. c. Extent of pavement. d. Soil type and soil conditions (such as frost cap, moisture and natural venting). <p>Grade 2 leaks should be reevaluated at least once every six months until cleared. The frequency of reevaluation should be determined by the location and magnitude of the leakage condition.</p> <p>Grade 2 leaks may vary greatly in degree of potential hazard. Some Grade 2 leaks, when evaluated by the above criteria, may justify scheduled repair within the next 5 working days.</p> <p>Others will justify repair within 30 days. During the working day on which the leak is discovered, these situations should be brought to the attention of the individual responsible for scheduling leak repair.</p> <p>On the other hand, many Grade 2 leaks, because of their location and magnitude, can be scheduled for repair on a normal routine basis with periodic reinspection as necessary.</p>	<p>A. <i>Leaks Requiring Action Ahead of Ground Freezing or Other Adverse Changes in Venting Conditions.</i> Any leak which, under frozen or other adverse soil conditions, would likely migrate to the outside wall of a building.</p> <p>B. <i>Leaks Requiring Action Within Six Months</i></p> <ol style="list-style-type: none"> 1. Any reading of 40% LEL, or greater, under a sidewalk in a wall-to-wall paved area that does not qualify as a Grade 1 leak. 2. Any reading of 100% LEL, or greater, under a street in a wall-to-wall paved area that has significant gas migration and does not qualify as a Grade 1 leak. 3. Any reading less than 80% LEL in small substructures (other than gas associated substructures) from which gas would likely migrate creating a probable future hazard. 4. Any reading between 20% LEL and 80% LEL in a con-fined space. 5. Any reading on a pipeline operating at 30 percent SMYS, or greater, in a class 3 or 4 location, which does not qualify as a Grade 1 leak. 6. Any reading of 80% LEL, or greater, in gas associated sub-structures. 7. Any leak which, in the judgment of operating personnel at the scene, is of sufficient magnitude to justify scheduled repair.

TABLE 3C-LEAK CLASSIFICATION AND ACTION CRITERIA-GRADE 3

GRADE	DEFINITION	ACTION CRITERIA	EXAMPLES
3	A leak that is non-hazardous at the time of detection and can be reasonably expected to remain non-hazardous.	These leaks should be reevaluated during the next scheduled survey, or within 15 months of the date reported, whichever occurs first, until the leak is regraded or no longer results in a reading.	<p><i>Leaks Requiring Reevaluation at Periodic Intervals</i></p> <ol style="list-style-type: none"> 1. Any reading of less than 80% LEL in small gas associated substructures. 2. Any reading under a street in areas without wall-to-wall paving where it is unlikely the gas could migrate to the out-side wall of a building. 3. Any reading of less than 20% LEL in a confined space.