

EMISSIVITY EVALUATION OF FIXED POINT BLACKBODIES

Sergey Mekhontsev, Vladimir Khromchenko, Alexander Prokhorov, Leonard Hanssen

National Institute for Standards and Technology, Gaithersburg, MD, USA

ABSTRACT

A new facility for the characterization of infrared spectral emittance of materials has recently been developed at NIST. The facility operation is based on measurements of a sample's spectral radiance and surface temperature with help of a set of variable temperature blackbodies and a spectral comparator. For highest accuracy, variable temperature blackbodies are calibrated in spectral radiance against a pair of fixed-point blackbodies with interchangeable crucibles of In, Sn, and Zn, and Al, Ag, and Cu, respectively. The spectral emissivity of the fixed-point blackbodies also needs to be accurately characterized. We employ a multi-prong approach: (1) Monte Carlo ray-trace modeling and calculations, (2) hemispherical reflectance measurements of the crucible cavity material flat sample, as well as the cavity itself, (3) direct spectral emittance measurements of the same samples using the facility, and (4) comparison of the fixed point blackbodies with each other as well as with variable temperature heat pipe blackbodies, using filter radiometers and the facility's Fourier transform spectrometer. The Monte Carlo code is used to predict the cavity emissivity with input of the cavity shape and the emissivity and specularity of the cavity material. The reflectance measurements provide emissivity data of both the material and the cavity at room temperature. The results are used to compare with and validate the code results. The direct emittance measurements of the material provide the temperature dependence of the material emittance as code input. The code predicted results for the cavities at their operating temperature (freeze points) are then compared with the relative spectral radiance measurements. Use of this complete set of evaluation tools enables us to obtain the spectral emissivity of the blackbodies with reliably determined uncertainties.

1. INTRODUCTION

As described in an earlier paper [1], a direct emissivity measurement system has recently been developed at NIST operates as a spectral radiance comparator, with a set of variable temperature blackbodies serving as transfer reference sources. Sources are compared by means of a Fourier Transform Infrared (FTIR) spectrometer, as well as a set of filter radiometers and a radiation pyrometer. While every effort has been made to build these blackbody sources to deliver the best possible performance, the emissivity and uniformity of their cavities, as well as the accuracy of their temperature sensors require independent verification.

As a result, it was decided to realize a series of metal freezing fixed point blackbodies to serve as primary standards of spectral emissivity in the thermal infrared region. This paper presents our efforts to evaluate the uncertainties of these blackbodies.

2. FIXED POINT BLACKBODIES DESIGN

For the fixed point blackbodies we have designed and built two furnaces, each accommodating three different types of crucibles containing high purity metals. The overall design of the fixed point blackbody sources is shown in Figure 1 below. Our design was driven by the requirements of minimizing the size of source error while at the same time achieving high emissivity for a relatively large opening diameter of 7 mm.

Every effort is made to ensure that no hot parts are visible through the opening port within the field of view ($F:7$ or smaller). We achieve this by minimizing the distance from the crucible to the exit

port and the placement of a water-cooled baffle (Figure 1). Such a design also necessitated the unusual geometry of the heat pipe liner to ensure isothermal conditions of the front part of the crucible. We believe that this design has effectively eliminated the unpredictable pyrometer errors due to out of field scatter, which is hard to compensate especially while using fixed point blackbodies.

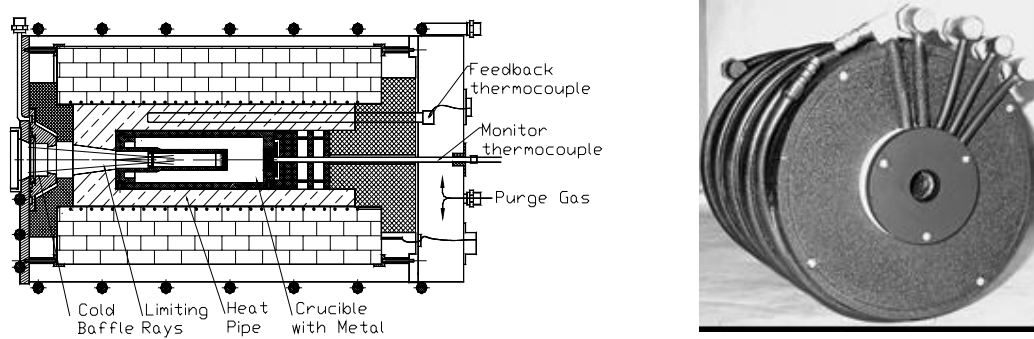

Figure 1. Design of the fixed point blackbody

The fixed point crucibles have a capacity of 120 cm³ of 6N purity metal and are made from graphite with 10 parts per million ash contents. The initial cavity geometry (Figure 2 (a), shown to scale)) was modeled using commercially available software and graphite emissivity data measured with the NIST FTIR spectrophotometric facility [2] at room temperature (Figure 3). The results were found to be below our target specification. So a second design employing a grooved bottom and an extended cavity (Figure 2(b)) was adopted. The predicted values of the effective spectral emissivity for isothermal conditions are shown in the Figure 4.

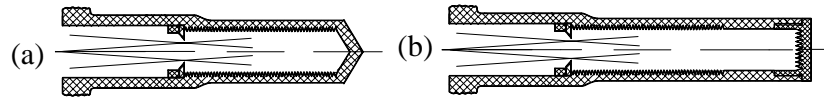

Figure 2. Designs of the fixed point blackbody cavity - (a) with a conical bottom and (b) with a grooved one.

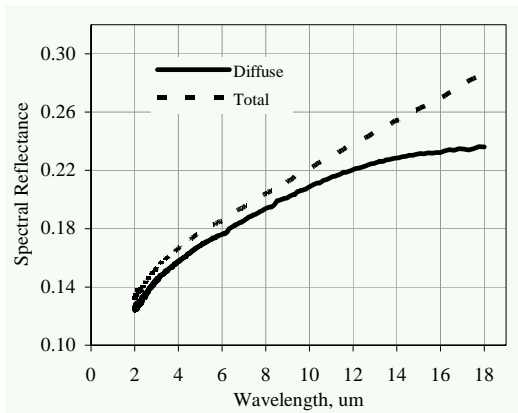

Figure 3. Flat graphite sample spectral directional-hemispherical reflectance and its diffuse component measured for incidence angle of 8°.

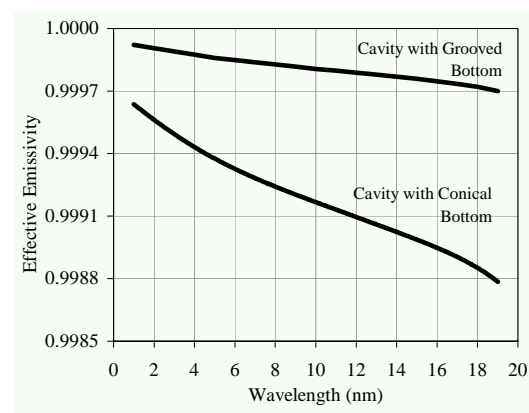

Figure 4. Spectral effective emissivity of two shapes of radiating cavity computed for wall diffusivity $D = 0.55$.

3. CAVITY REFLECTOMETRY AND COMPARISON WITH MODELING

The measured spectral reflectance shown in Figure 3 was used as initial data for the effective emissivity computation of a radiating cavity. The computation was performed by the Monte Carlo method [3]. The computational method employs the specular-diffuse model of reflection. According to the data depicted in Figure 3, the diffusivity (the ratio of diffuse reflectance to the sum of its diffuse and specular reflectance) varies approximately from 0.95 at 2 μm to 0.8 at 19 μm . However, the diffusivity of a surface depends also on its mechanical and thermal treatment as well as on incidence angle. In particular, the internal surface of a cavity after machining may have a higher specular component of reflection, especially for large angles of incidence. To evaluate the average diffusivity for such conditions, we compared the computed and measured effective emissivity of a sample with concentric V-grooves. The reciprocity principle was used: the viewing conditions for the computation of effective emissivity reproduce the conditions of irradiation for the reflectance measurements. The spectral effective emissivity computed for two values of diffusivity as well as measured is shown in Figure 5. The computed curve for $D = 0.55$ (not depicted) has good agreement with the measured curve.

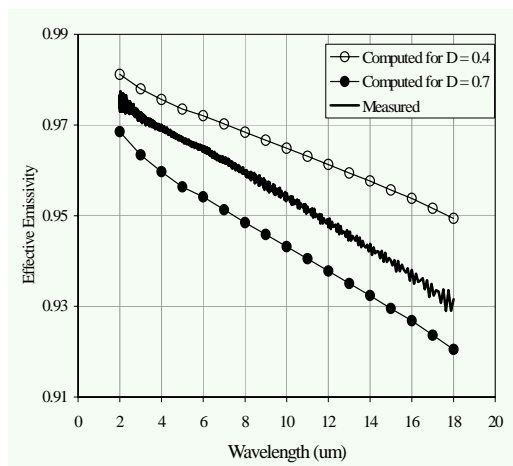

Figure 5. Measured and computed spectral effective emissivity of a sample with concentric V-grooves

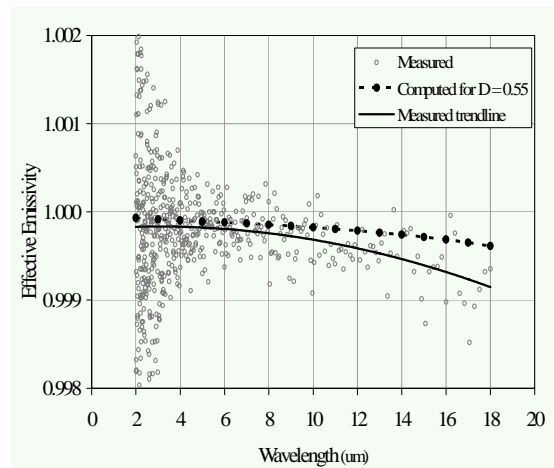

Figure 6. Measured and computed spectral effective emissivity of a cavity with V-grooved bottom

The computed curve for the effective emissivity of a cavity with a V-grooved bottom and measured data (calculated from the cavity spectral reflectance) are depicted in Figure 6. During the measurements, the interferometer's beam was focused onto the center of cavity's aperture and underfills the cavity bottom. The comparison shows reasonable agreement, but further characterization is required to obtain reasonable uncertainty levels. This includes measurements of the cavity bi-directional distribution function (BRDF) to evaluate the retro-reflected component that is not provided by the system's integrating sphere.

4. TRANSFER STANDARD PYROMETER MEASUREMENTS

Another characterization of the fixed point blackbody emissivity was performed by a recently constructed high temperature transfer standard pyrometer shown in Figures 7 and 8. The pyrometer uses mostly off the shelf components and is equipped with a single AR-coated lens. Two units were made: S/N 101 and 102.

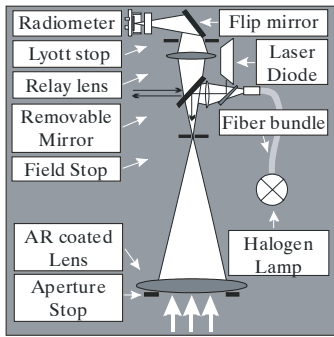

Figure 7. Principal components of the pyrometer

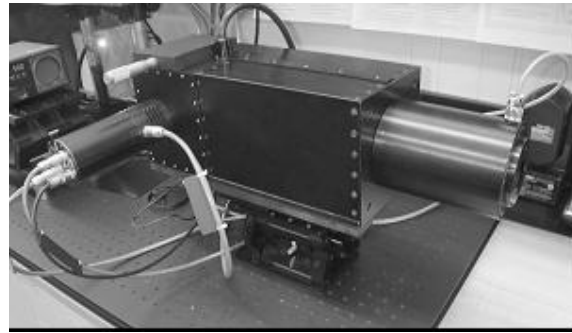

Figure 8. Picture of the assembled transfer standard pyrometer

After characterization of its relative spectral responsivity by the NIST spectral responsivity facility [4], we examined the out of field scattering of the pyrometer. For this purpose we constructed a simple device, shown in Figure 9, for Size of Source Effect (SSE) measurements. (This device has proven to be quite practical because of its compact size and flexibility of use.)

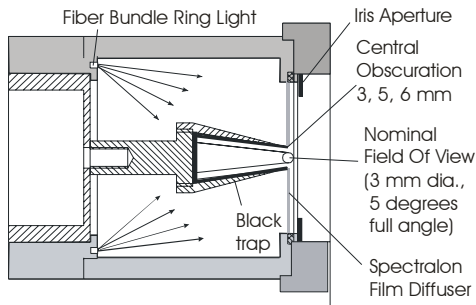

Figure 9. Broad band device for Size-of-Source Effect measurements by the central obscuration method

The SSE results obtained for the pyrometer are shown in Figures 10 and 11; they exhibit good performance. For the particular case of our blackbody comparison, where the hot area diameter does not exceed 8 mm, the correction for SSE amounts to a few parts in 10^5 and is considered negligible. For measurements of sample or hot plate source, a more substantial correction of up to several parts in 10^4 may be necessary.

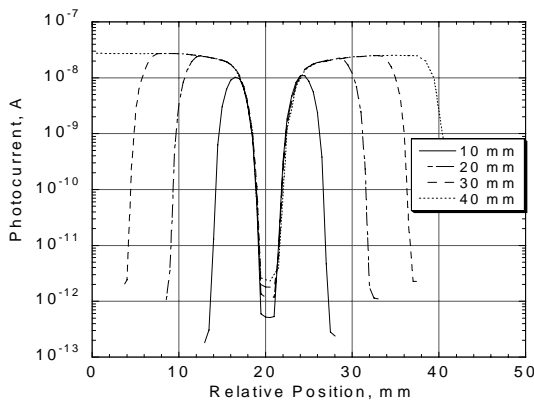

Figure 10. Results of pyrometer scanning across the SSE source with obscuration 6 mm and different outer diameter

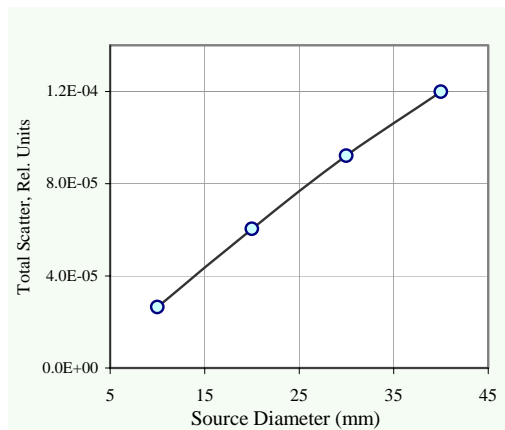

Figure 11. Total out of field scatter (SSE) performance of the NIST transfer standard pyrometer

Following the described pyrometer characterization, both units 101 and 102 were used to examine the fixed point blackbody equipped first with the Al and then the Ag crucibles. The fixed point performance was found to be satisfactory, with a typical plateau duration ranging from 1 to 3 hrs and the agreement of melt and freeze temperatures is within 1 mK. The standard deviation of temperature during the plateau operation shown in Figure 12 was 0.1 mK.

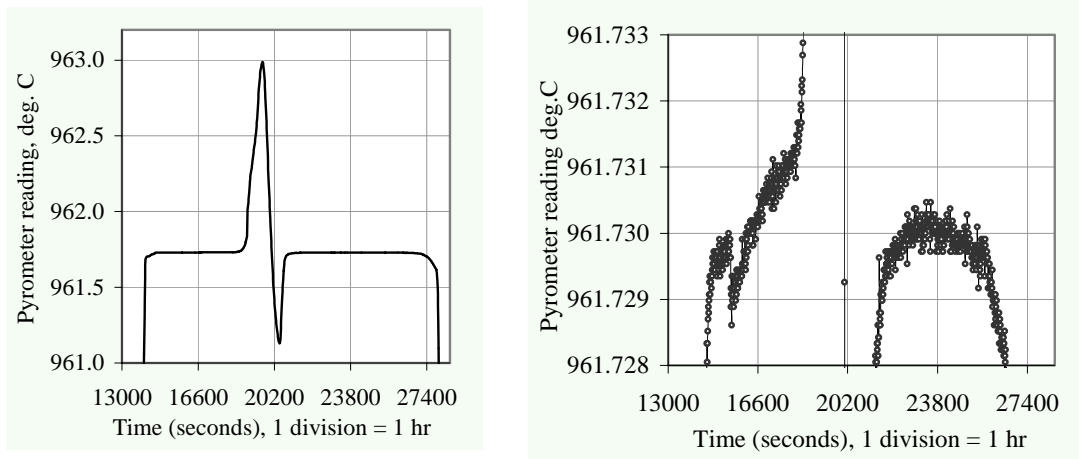

Figure 12. Transfer pyrometer readings during silver freezing and melting plateau after calibration using aluminum fixed point results. The standard deviation of the temperature reading during the freeze is 0.1 mK

As a result of each fixed point blackbody measurement, we were able to assign an absolute responsivity scale to the pyrometer (Figure 13) by finding the appropriate normalization factors. After performing these calibrations for both pyrometer units at several fixed points, we obtained fairly good agreement of these absolute scales (Table 1).

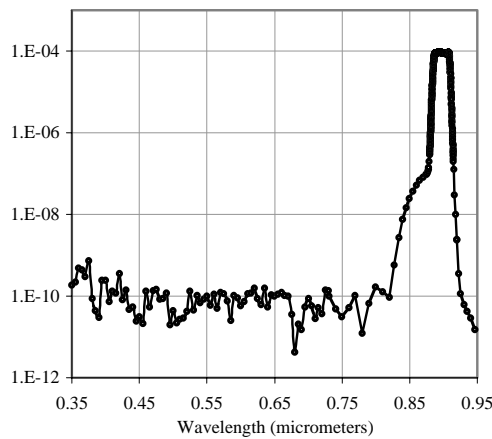

Figure 13. Typical pyrometer absolute responsivity curve, measured using relative responsivity and fixed point calibrations

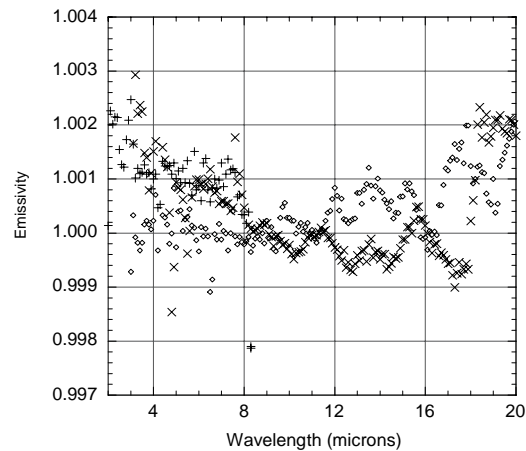

Figure 14. Overlaid results of spectral comparison of Cs vs Na heat pipe blackbodies by multiple detectors

The above results can prove only that our fixed point blackbodies are non-selective within a few parts in 10^4 at the calibration wavelength (900 nm). To characterize the blackbody performance over the entire mid-IR range we plan to perform a direct comparison of two fixed point blackbodies using the spectral radiance comparator of the high temperature emissivity facility.

Table 1: Results of fixed point blackbody comparison with transfer standard pyrometers.

Measured temperature deviation from calculated using Ag point (961.78 °C) calibration	Pyrometer 101		Pyrometer 102	
	Radiance	Temperature	Radiance	Temperature
660.323 °C (Aluminum)	- 0.033%	-18 mK	- 0.046%	- 25 mK
1064.18 °C (Gold)	0.023%	25 mK	No data	

Currently we have been able to achieve acceptable relative expanded uncertainty levels of comparison (0.1% ; $k = 2$) in the range of 2 to 20 μm only for sources with nearly identical temperatures. An example is shown in Figure 14; the results of a comparison of a cesium heat pipe blackbody vs. a sodium heat pipe blackbody.

5. CONCLUSION AND FUTURE PLANS

The measurements and modeling results we have obtained serve as a foundation for the uncertainly evaluation of the infrared spectral radiance and emissivity scales currently being established at NIST. At the same time all presented experimental data is still a work in progress, and it is expected that the following new results should complement our current results: (1) a direct spectral comparison of Zinc and Aluminum fixed point blackbodies with a Fourier transform comparator, (2) a comparison of all our fixed point blackbodies by means of filter radiometers, (3) a more accurate cavity absorptance evaluation by means of a laser based BRDF facility. In addition, a new absolute spectral radiance mode calibration of the pyrometer at the NIST SIRCUS facility [5] is currently underway. This will enable linking of the blackbody radiance to an absolute cryogenic radiometer and allow direct measurements of blackbody emissivity.

ACKNOWLEDGEMENTS

We would like to acknowledge the valuable input of George Eppeldauer, Tom Larason, Steven Brown, Alex Gura and Robert Saunders (all at NIST) in the pyrometer design and characterization, and Gregory Strouse (NIST) and Ortwin Brost (IKE, Stuttgart) in the blackbody design.

REFERENCES

- [1] Hanssen L. M., Khromchenko V. B., Mekhontsev S. N., "Infrared spectral emissivity characterization facility at NIST," Proceedings of the SPIE, V. 5575, 1-12 (2004)
- [2] Hanssen L. M., Kaplan S. G., "Infrared diffuse reflectance instrumentation and standards at NIST," Analytica Chimica Acta 380, 289-302 (1998)
- [3] Sapritsky V.I. and Prokhorov A. V. Spectral effective emissivities of nonisothermal cavities calculated by the Monte Carlo method. Appl. Opt. V. 34, 5645–5652 (1995).
- [4] Larason T.C., Bruce S.S., and Cromer C.L., The NIST High Accuracy Scale for Absolute Spectral Response from 406 nm to 920 nm, J. Res. Natl. Inst. Stand. Technol. V. 101, 133 -140 (1996).
- [5] Parr A.C., "The candela and radiometric and photometric measurements", J. Res. Natl. Inst. Stand. Technol. V. 106, 151–186 (2000)

Addresses of the Authors:

National Institute of Standards and Technology, 100 Bureau Dr., Stop 8442, Gaithersburg, MD, USA, tel. 301 975 2344, fax 301 840 8551, e-mail: hanssen@nist.gov, website: www.nist.gov