

Covered Bridge Manual

PUBLICATION NO. FHWA-HRT-04-098

APRIL 2005



U.S. Department of Transportation
Federal Highway Administration

Research, Development, and Technology
Turner-Fairbank Highway Research Center
6300 Georgetown Pike
McLean, VA 22101-2296



FOREWORD

The Transportation Equity Act for the 21st Century (TEA-21) as amended by the TEA-21 Restoration Act established the National Historic Covered Bridge Preservation Program (NHCBBP). This program includes preservation of covered bridges that are listed, or are eligible for listing, on the National Register of Historic Places. It includes research for better means of restoring and protecting covered bridges. It also includes technology transfer to disseminate information on covered bridges as a means of preserving our cultural heritage. The development of the *Covered Bridge Manual* is one of the research projects funded through NHCBBP.

The broad objectives of the NHCBBP research program are to find means and methods to restore and rehabilitate historic covered bridges to preserve our heritage using advanced technologies, and to assist in rehabilitating and restoring these bridges. The specific objectives of this research project are to provide comprehensive support to those readers involved with maintaining, assessing, strengthening, or rehabilitating any covered bridge.

The manual is intended primarily for engineers and historic bridge preservationists to provide technical and historical information on preservation of covered bridges. It will also be of interest to others involved with these bridges—including lay people, owners, and contractors.

The manual is separated into several sections with a number of chapters devoted to the specifics of each. The sections include background, description of bridge components, technical engineering issues, existing bridges, and references. The appendices include multiple case studies of existing bridge rehabilitation and construction of new authentic covered bridges.

This manual does not supersede any other. This publication is the final version of the manual.

Notice

This document is disseminated under the sponsorship of the U.S. Department of Transportation in the interest of information exchange. The U.S. Government assumes no liability for the use of the information contained in this document. This report does not constitute a standard, specification, or regulation.

The U.S. Government does not endorse products or manufacturers. Trademarks or manufacturers' names appear in this report only because they are considered essential to the objective of the document.

Quality Assurance Statement

The Federal Highway Administration (FHWA) provides high-quality information to serve Government, industry, and the public in a manner that promotes public understanding. Standards and policies are used to ensure and maximize the quality, objectivity, utility, and integrity of its information. FHWA periodically reviews quality issues and adjusts its programs and processes to ensure continuous quality improvement.

Technical Report Documentation Page

1. Report No. FHWA-HRT-04-098	2. Government Accession No.	3. Recipient's Catalog No.	
4. Title and Subtitle Covered Bridge Manual		5. Report Date April 2005	
		6. Performing Organization Code	
7. Author(s) Phillip C. Pierce, P.E., Robert L. Brungraber, P.E., Ph.D., Abba Lichtenstein, P.E., and Scott Sabol, P.E. Chapter 19 was authored by J.J. Morrell, Department of Wood Science and Engineering, Oregon State University and S.T. Lebow, U.S. Forest Products Laboratory, Madison, WI.		8. Performing Organization Report No.	
9. Performing Organization Name and Address Phillip C. Pierce, P.E. 6738 County Highway 14 Treadwell, NY 13846		10. Work Unit No. (TRAIS)	
		11. Contract or Grant No. DTFH61-00-C-00116	
12. Sponsoring Agency Name and Address Turner-Fairbank Highway Research Center (HR D1-07) Federal Highway Administration 6300 Georgetown Pike McLean, VA 22101-2296		13. Type of Report and Period Covered Final Report October 2000- November 2004	
		14. Sponsoring Agency Code	
15. Supplementary Notes Contracting Officer's Technical Representative (COTR), Sheila Rimal Duwadi, P.E., Office of Infrastructure Research and Development (R&D); John O'Fallon, P.E., Office of Infrastructure R&D			
16. Abstract This manual provides guidance to those involved with all aspects of the work, from initial inspection and evaluation, through the engineering of rehabilitation, to construction issues. Broadly speaking, this manual covers general terminology and historic development of covered bridges. The manual also addresses loads, structural analysis, connections, and design issues. The last six chapters contain discussions of evaluation, maintenance, strengthening, and preservation of existing covered bridges; historic considerations of existing structures; and provide a state-of-the-art guide on wood preservatives for covered bridges. Historic preservation requirements as they relate to the U.S. Department of Interior standards for these important and unusual structures also are provided. The appendices include an extensive series of case studies. The manual focuses on the nuances of the engineering aspects of covered bridges, including some issues not addressed currently by national bridge specifications. The chapter on timber connections provides a comprehensive discussion of covered bridge joinery and represents an important contribution to covered bridge engineering.			
17. Key Words Covered, Bridge, Manual, Design, Construction, Rehabilitation, Historic, Preservation		18. Distribution Statement No restrictions. This document is available to the public through the National Technical Information Service (NTIS), Springfield, VA 22161	
19. Security Classif. (of this report) Unclassified	20. Security Classif. (of this page) Unclassified	21. No. of Pages 341	22. Price

PREFACE

This manual attempts to fill in gaps in the literature about the nuances of covered bridges. It deals with quirks about them known to the team of four experienced engineers who have prepared this manual. Yet, the relatively small number of covered bridges in the United States and their geographic dispersion makes it impractical for any team to have first-hand knowledge of all aspects of all covered bridges. There are, no doubt, some issues that have not been included herein.

For readers who have attempted to document the strength of covered bridges, this manual may not contain the answers to all questions. There are several things about covered bridges that continue to defy explanation: How have they survived as long as they have, subject to the abuse of vehicles weighing substantially more than the vehicles familiar to the builders of these bridges? How does an engineer explain the discrepancy between theoretical weakness and observed performance?

Some research projects have focused specifically on various aspects of covered bridges, and research continues. Yet the relatively small number of covered bridges makes the potential return on investment in that research relatively limited, and other research awaits funding.

Having offered the above caveat, we hope this manual is interesting and useful.

SI* (MODERN METRIC) CONVERSION FACTORS

APPROXIMATE CONVERSIONS TO SI UNITS

Symbol	When You Know	Multiply By	To Find	Symbol
LENGTH				
in	inches	25.4	millimeters	mm
ft	feet	0.305	meters	m
yd	yards	0.914	meters	m
mi	miles	1.61	kilometers	km
AREA				
in ²	square inches	645.2	square millimeters	mm ²
ft ²	square feet	0.093	square meters	m ²
yd ²	square yard	0.836	square meters	m ²
ac	acres	0.405	hectares	ha
mi ²	square miles	2.59	square kilometers	km ²
VOLUME				
fl oz	fluid ounces	29.57	milliliters	mL
gal	gallons	3.785	liters	L
ft ³	cubic feet	0.028	cubic meters	m ³
yd ³	cubic yards	0.765	cubic meters	m ³
NOTE: volumes greater than 1000 L shall be shown in m ³				
MASS				
oz	ounces	28.35	grams	g
lb	pounds	0.454	kilograms	kg
T	short tons (2000 lb)	0.907	megagrams (or "metric ton")	Mg (or "t")
TEMPERATURE (exact degrees)				
°F	Fahrenheit	5 (F-32)/9 or (F-32)/1.8	Celsius	°C
ILLUMINATION				
fc	foot-candles	10.76	lux	lx
fl	foot-Lamberts	3.426	candela/m ²	cd/m ²
FORCE and PRESSURE or STRESS				
lbf	poundforce	4.45	newtons	N
lbf/in ²	poundforce per square inch	6.89	kilopascals	kPa

APPROXIMATE CONVERSIONS FROM SI UNITS

Symbol	When You Know	Multiply By	To Find	Symbol
LENGTH				
mm	millimeters	0.039	inches	in
m	meters	3.28	feet	ft
m	meters	1.09	yards	yd
km	kilometers	0.621	miles	mi
AREA				
mm ²	square millimeters	0.0016	square inches	in ²
m ²	square meters	10.764	square feet	ft ²
m ²	square meters	1.195	square yards	yd ²
ha	hectares	2.47	acres	ac
km ²	square kilometers	0.386	square miles	mi ²
VOLUME				
mL	milliliters	0.034	fluid ounces	fl oz
L	liters	0.264	gallons	gal
m ³	cubic meters	35.314	cubic feet	ft ³
m ³	cubic meters	1.307	cubic yards	yd ³
MASS				
g	grams	0.035	ounces	oz
kg	kilograms	2.202	pounds	lb
Mg (or "t")	megagrams (or "metric ton")	1.103	short tons (2000 lb)	T
TEMPERATURE (exact degrees)				
°C	Celsius	1.8C+32	Fahrenheit	°F
ILLUMINATION				
lx	lux	0.0929	foot-candles	fc
cd/m ²	candela/m ²	0.2919	foot-Lamberts	fl
FORCE and PRESSURE or STRESS				
N	newtons	0.225	poundforce	lbf
kPa	kilopascals	0.145	poundforce per square inch	lbf/in ²

*SI is the symbol for the International System of Units. Appropriate rounding should be made to comply with Section 4 of ASTM E380.
(Revised March 2003)

TABLE OF CONTENTS

Chapter 1. Introduction	3
Chapter 2. Covered Bridges: Form, Use, and Terminology	7
The “Typical” Covered Bridge.....	7
The Typical Setting.....	8
Vehicular Loading	8
Water Crossing	9
Vehicle Opening.....	9
Component Terminology	10
Facts about Covered Bridges.....	20
Oldest Covered Bridge in United States	20
Length.....	21
Locations.....	22
Types of Supporting Trusses.....	23
Reasons for Using Covered Bridges vs. Other Alternatives	25
Chapter 3. Historical Development of Covered Bridges	27
The Development of Truss Concepts in Europe	27
Early Truss Construction in the United States.....	28
The First Covered Bridge in the United States.....	29
Patents and Covered Bridges.....	29
Prevalence, Prominence, Demise, and Resurgence.....	31
Chapter 4. Types of Longitudinal Trusses	35
Kingpost.....	35
Queenpost.....	36
Multiple Kingpost	37
Burr Arch.....	40
Town Lattice	42
Long Truss.....	43
Howe Truss.....	45
Other.....	46
Chapter 5. Floor Systems	49
Floor Beams	51
Bending.....	51
Shear.....	51
Live Load Deflection	53
Typical Theoretical Weakness of Floor Beams	53
Consideration of Distribution Beams	54
Other Issues with Floor Beams.....	55
Typical Floor Beams	55
Stringers	55
Decking.....	56
Plank Decking	56
Nail-Laminated Decking.....	57
Glue-Laminated Decking	57
Running Planks	58
Replacement Floor Systems	59
Chapter 6. Ancillary Features.....	63
Roof	63
Style	63
Materials	64
Roof Boards	64
Rafters	65
Configuration.....	65
Ties or Struts.....	65
Engineering Challenges Related to Rafters.....	66
Portals	67
Siding.....	68

Bracing	69
Upper Chord Tie Beams	69
Lateral Bracing Systems	69
Knee Braces	70
Check Braces	72
Chin Braces	73
Traffic Railing	74
Bridge Railing	74
Approach Railing	75
Chapter 7. Foundations	79
Types of Foundations	79
Common Conditions of Foundations	81
Foundation Challenges	83
Support Features	84
Bearing Blocks	84
Bolster Beams	85
Hold-Downs	86
Chapter 8. The Engineering Challenge	91
Overview	91
Why Do They Stand?	92
Chapter 9. Design and Analysis Specifications	93
American Association of State Highway and Transportation Officials	93
The National Design Specifications for Wood Construction	94
Specifications for Minimum Loads	94
Other Building Specifications	95
Glued-Laminated Timber Specifications	95
Chapter 10. Issues Related to Wood	97
Terminology	97
Wood Typical to Historic Covered Bridges	97
Wood Availability for Repairs	98
Seasoned Versus Green Wood	99
Sawing / Sizing / Finishing	100
Nuances of Glulam Components	101
Wood Preservatives	102
Chemically Treated Wood	103
Fire Retardants	104
Protective Finish Treatments	104
Chapter 11. Loads	107
Dead Load (Self-Weight)	107
Vehicular Loads (Live Load)	108
Standard Design Vehicles	108
Design Vehicle for Covered Bridges	110
Posted Weight Restrictions	111
Other Live Load Issues	111
Snow Load	111
Wind Load	112
Other Loads	114
Load Combinations and Load Duration	115
Chapter 12. Force and Stress Analysis Issues	119
Truss Analysis–Basics	119
Simplified Truss Analysis	120
Refined Truss Analysis	121
Combined Truss and Arch Analysis	123
Effect of Bolster Beams	124
Floor Analysis	125
Floor Beams	125
Distribution Beams	127

Stringers.....	128
Decking	129
Bracing Analysis.....	129
Chapter 13. Design Issues	131
Material Properties/Allowable Stresses.....	131
NDS Penalty for Tension Stresses in Large Members	133
Horizontal (or Along-the-Grain) Shear.....	134
General	134
Nuances of Loading Location As It Relates to Horizontal Shear Stresses.....	135
Chapter 14. Connections	137
Introduction.....	137
Truss Connections–Trusses Other Than Town Lattice	137
Tensile Member Connections	137
Compression Member Connections	149
Connections of Diagonals to Chords	150
Connections of Verticals to Chords	152
Connections between Diagonals and Verticals	153
Timber Counter Connections	156
Bearing Blocks in Howe Trusses–Diagonals and Verticals at Chords	157
Long Truss Wedges.....	158
Truss Connections–Town Lattice Trusses	158
Traditional Lattice–General.....	158
Chord Terminations/Butt Joints in the Chords	160
Chord to Lattice Connections.....	161
Lattice to Lattice Connections.....	162
Bolts Versus Wooden Pegs	162
Sister Elements.....	163
Lattice Posts	164
Vertical Ends.....	164
Inclined Lattice Truss Ends.....	167
Intermediate Lattice Truss Posts	168
Recommendations for Lattice Truss Posts	168
Lattice Member Tails at Bearing Points	169
Arch Bearing Pads and Arch Connections to Sandwiched Truss Elements	169
Overhead Bracing.....	171
Tie Beam to Truss Top Chord.....	171
Upper Lateral Connections	172
Knee Braces	173
Rafter Plates in Short Kingpost and Queenpost Trusses	174
Floor Connections	177
Decking to Stringers or Floor Beams	177
Stringers to Floor Beams	177
Floor Beams to Trusses.....	177
Lower Lateral Bracing.....	178
Roofing and Siding	179
Rafter Connections	179
Siding	179
Chapter 15. Evaluating Existing Bridges.....	183
Field Examination and Inspection	183
Wood Species Identification	187
Timber Grading.....	187
Individual Member Assessment Through Strength Ratio Concepts.....	187
Analytical Evaluations for Vehicle Capacities (Load Rating).....	187
Analytical Evaluation for Pedestrian Density Capacities	189
Load Testing.....	189
Destructive Testing of Components Removed From Bridges	191
Chapter 16. Repairing and Strengthening Existing Structures	193

Repair of Trusses	193
Common Ways to Strengthen Covered Bridge Trusses	197
Less Authentic Repair and Strengthening of Trusses	200
New Methods of Strengthening Trusses	202
Floor System Repair and Strengthening	203
Summary of Recommended Actions	204
Example Projects	205
Chapter 17. Preserving Existing Covered Bridges	207
Roofing and Siding	207
Roadway Drainage	208
Foundation Support Details	210
Regular Cleaning	211
Fire Protection	212
In Situ Chemical Treatment	212
Painting or Treating Siding	213
Retightening Connectors	213
Chapter 18. Historic Considerations With Existing Structures	215
National Register of Historic Places	215
Historic American Engineering Record	216
State Historic Preservation Offices	216
The Advisory Council on Historic Preservation	216
U.S. Secretary of Interior’s Standards for Historic Preservation	217
Chapter 19. Initial Preservative Treatment of Wood in Covered Bridges	219
Introduction	219
Evaluating the Need for Preservative Treatment	219
Types of Deterioration	220
Molds and Stains	220
Decay Fungi	220
Wood Boring Insects	221
Preventing Fungal and Insect Attack	222
Methods of Preservative Treatment	222
Environmental Considerations for Treatment	223
Treatment Specifications	224
Methods for Improving Performance of Treated Wood	225
Preservative Chemicals	225
Preservatives That Are Effective in High-Decay Hazard Applications	227
Preservatives That are Effective Above Ground, Fully Exposed to the Weather	234
Preservatives That are Effective Above Ground with Partial Exposure and Occasional Wetting	235
Preservatives That are Effective Above Ground, Occasionally Damp, But Protected from Liquid Water	238
Conclusions	239
Appendix A. Those Intriguing Town Lattice Timber Trusses	243
Introduction	243
Description of the Truss	243
The Problem	244
Alternative Approaches	244
The Latest Chapter	245
Appendix B. The Trials and Successes of Covered Bridge Engineering and Construction—Hamden Covered Bridge, Delaware County, NY	249
Abstract	249
Introduction	249
Description of the Bridge	249
Pre-rehabilitation Conditions	250
Engineering and Construction Challenges	250
How, and How-Not, to Move a Covered Bridge	250
Bottom Chord Splices	251
Comparing Bracing—Previous versus New	253

High-End Web Member Stresses	253
The Myth and Reality of Colonel Long’s Wedges	254
Connectors in Joints of the Long Truss	255
How Tight Should the Counters Be?	256
Upper Lateral System Diagonals—How to Maintain Tight Fit?	257
Completed Bridge	257
Appendix C. Rehabilitation of Fitch’s Covered Bridge	259
History of the Bridge and Condition Prior to Current Project	259
Modifications/Rehabilitation as Part of Current Project	262
Original and New Construction Techniques	265
Problems and Solutions	266
Hidden Deterioration	266
Replacement of Top Chord Elements	266
Vertical Camber of the Trusses	266
Research Conducted	267
Costs	267
Final Project Photos	268
Appendix D. Rehabilitation and Resiting of the Brown’s River Covered Bridge, Westford, VT	271
Bridge Description and Project Background	271
Engineering and Construction Challenges	271
Bridge Condition at the Start of the Project	271
Limited Engineering	272
Timber Repairs	272
Modified Burr Arch Details	275
Foundation Considerations	275
Roof Replacement	276
Relocation of the Bridge	276
Appendix E. A Tale of Two Bridges	279
Speed River Covered Bridge, Guelph, Ontario, Canada	279
Twin Bridges, North Hartland, VT	281
Appendix F. Smith Covered Bridge Over the Baker River	285
Introduction	285
Bridge Dimensions and Details	285
Main Truss and Arch Configuration	285
Floor System Configuration	286
Superstructure Materials	286
Substructure Configuration	286
Superstructure Fabrication and Erection	286
Construction Costs	286
Project Photographs	287
Appendix G. Caine Road Covered Bridge, Ashtabula County, OH	289
Appendix H. Replacement of the Mill Covered Bridge, Tunbridge, VT	295
Mill Bridge at Tunbridge, VT	296
Appendix I. Rehabilitation of the Paper Mill Covered Bridge, Bennington, VT	301
Appendix J. Replacement of the Power House Covered Bridge, Johnson, VT	305
References	313
Other Resources	315
Nontechnical Covered Bridge Information	315
Technical Information—Books / Articles Relevant to Covered Bridges	320
Articles Related to Covered Bridges	322
Covered Bridge Societies	327

LIST OF FIGURES

Figure 1. Chiselville Bridge, Sunderland, VT.	1
Figure 2. Eagleville Bridge, Washington County, NY.	1
Figure 3. A classic historic covered bridge, the Taftville Bridge, Woodstock, VT.	3
Figure 4. Typical covered bridge, Upper Falls Bridge, Weathersfield, VT.	7
Figure 5. Pony truss covered bridge, Comstock Bridge, East Hampton, CT.	8
Figure 6. Bridge diagram—general terminology.	11
Figure 7. Diagram of queenpost truss—general terminology.	12
Figure 8. Floor system with stringers and floor beams—Warren Bridge, VT.	13
Figure 9. Floor system with floor beams, but without stringers—Hutchins Bridge, VT.	13
Figure 10. Running planks—Hutchins Bridge, VT.	14
Figure 11. An unusual upper lateral system—Seguin Bridge, VT.	15
Figure 12. Lower lateral system—Williamsville, VT.	16
Figure 13. Unusual ship knee braces—Village or Great Eddy Bridge, in Waitsfield, VT.	17
Figure 14. Shelter panel covering of truss ends—Fitch’s Bridge, Delaware County, NY.	18
Figure 15. A shelter panel separate from the trusses—Hamden Bridge, Delaware County, NY.	18
Figure 16. Framing of the independent shelter panel—Hamden Bridge, Delaware County, NY.	18
Figure 17. Foundations.	19
Figure 18. Bolster beams—Worrall’s Bridge, Rockingham, VT.	20
Figure 19. Blenheim Bridge—longest clear span in the United States.	22
Figure 20. Rare, old double-barrel covered bridge—Pulp Mill Bridge, Middlebury, VT.	27
Figure 21. Classic use of a natural formation as an abutment—Red Bridge, Morristown, VT.	29
Figure 22. Date carved in an end post of the Westford Bridge, Westford, VT—may be original to the bridge.	31
Figure 23. Salisbury Center Bridge—Herkimer County, NY.	33
Figure 24. Brown Bridge—Shrewsbury, VT.	33
Figure 25. Diagram of kingpost truss.	35
Figure 26. Diagram of kingpost truss with subdiagonals.	36
Figure 27. Diagram of queenpost truss.	37
Figure 28. Diagram of multiple kingpost trusses.	38
Figure 29. Shear failure of a vertical at a notch—Mill Bridge, Tunbridge, VT.	39
Figure 30. Example of a broken tail from ice impact—South Randolph Bridge, VT.	40
Figure 31. Bowing of bottom chord due to impact from ice floes—South Randolph Bridge, VT.	40
Figure 32. Diagram of conventional and modified Burr arch.	41
Figure 33. Connection of arch to post—Wehr Bridge, Lehigh County, PA.	42
Figure 34. Diagram of Town lattice truss.	43
Figure 35. Diagram of Long truss.	44
Figure 36. Long truss bottom chord wedge—Downsville Bridge, Delaware County, NY.	45
Figure 37. Wedges between counter and floor beam in a Long truss—Hamden Bridge, Delaware County, NY.	45
Figure 38. Diagram of Howe truss.	46
Figure 39. Diagram of Paddleford truss.	47
Figure 40. Transverse floor beams and longitudinal decking—Fitch’s Bridge, Delaware County, NY.	50
Figure 41. A floor with stringers, floor beams, and transverse decking—Comstock Bridge, East Hampton, CT.	50
Figure 42. Mortise-and-tenon connection in floor beam—Downsville Bridge, Delaware County, NY.	51
Figure 43. End notches of floor beams used in a Town lattice truss—West Dummerston Bridge, VT.	52
Figure 44. Timber dowel reinforcement of post—Mill Bridge, Tunbridge, VT.	53
Figure 45. Installation of distribution beams—Union Village Bridge, VT.	54
Figure 46. Typical transverse plank decking with running planks—Salisbury Center Bridge, Herkimer County, NY.	56
Figure 47. Nail-laminated decking being removed—Fitch’s Bridge, Delaware County, NY.	57
Figure 48. Glue-laminated floor beams and decking system under construction—Hamden Bridge, Delaware County, NY.	58
Figure 49. Running plank installation—Taftville Bridge, VT.	58

Figure 50. Independent floor system—Chisleville Bridge, VT. Note that the pier cap does not support the timber truss, which must still support the weight of the covering and snow.	60
Figure 51. Classic gable roof—Forks ville Bridge in Sullivan County, PA.	63
Figure 52. A flat roof bridge—Hogback Bridge, Madison County, IA.	64
Figure 53. Example of rafter ties—Northfield Falls Bridge, VT.	66
Figure 54. Unusual detailing of a portal—Upper Falls Bridge, Weathersfield, VT.	67
Figure 55. Example of portal extension—Wehr Bridge, Lehigh County, PA.	68
Figure 56. Lateral brace connection at tie beam—Fitch’s Bridge, Delaware County, NY.	70
Figure 57. Traditional knee brace—Salisbury Center Bridge, Herkimer County, NY.	71
Figure 58. Alternative and stronger style of knee brace—Hamden Bridge, Delaware County, NY.	71
Figure 59. Another alternative knee brace—Hopkins Bridge, Enosburgh, VT.	72
Figure 60. Check brace at bottom chord—Brown’s River Bridge, Westford, VT.	72
Figure 61. Check brace at top chord—Quinlan Bridge, Charlotte, VT.	73
Figure 62. Chin brace—Elder’s Mill Bridge, Watkinsville, GA.	74
Figure 63. Interior curbing—West Dummerston Bridge, VT.	75
Figure 64. Squeeze timber approach railing—Hamden Bridge, Delaware County, NY.	76
Figure 65. Approach railing and bridge curb—Paper Mill Bridge, Bennington, VT.	76
Figure 66. Transition from approach railing to inside curb—Mill Bridge, Tunbridge, VT.	77
Figure 67. Original stone high abutment in good condition—Upper Falls Bridge, Weathersfield, VT.	79
Figure 68. Supplemental pile bents—Hamden Bridge, Delaware County, NY.	80
Figure 69. Abutment stem and wing wall identification.	81
Figure 70. Badly cracked and shifted stones in the bottom of an abutment stem—Halpin Bridge, Middlebury, VT, before its replacement.	82
Figure 71. Parged stone abutment stem.	82
Figure 72. Damage to stone wall caused by tree roots.	83
Figure 73. Modified original stone abutment—Fitch’s Bridge, East Delhi, Delaware County, NY.	84
Figure 74. Bearing block installation—Brown’s River Bridge, Westford, Vermont.	85
Figure 75. Bolster beam—Fuller Bridge, Montgomery, VT.	86
Figure 76. Hold-down anchor—Paper Mill Bridge, Bennington, VT.	87
Figure 77. Thetford Center Bridge, exterior view, Thetford, VT.	89
Figure 78. Thetford Center Bridge, interior view, Thetford, VT.	89
Figure 79. Surface evidence of powder post beetles.	104
Figure 80. A covered bridge with painted siding—Wehr Bridge, Lehigh County, PA.	105
Figure 81. Example of bridge without protective treatment (the Westford Bridge in Vermont before its recent rehabilitation).	105
Figure 82. H20 design truck vehicle (after AASHTO standard specifications).	109
Figure 83. HS20 design truck vehicle (after AASHTO standard specifications).	109
Figure 84. Lane load configuration (after AASHTO standard specifications).	110
Figure 85. Snow load on covered bridges can cause failure—Power House Bridge, Johnson, VT.	112
Figure 86. A covered bridge destroyed by wind—Bedell Bridge between Haverhill, NH, and Newbury, VT, 1979.	113
Figure 87. Another example of collapse by wind—Smith Bridge at Brownsville, VT.	114
Figure 88. The Smith Bridge before collapse.	114
Figure 89. Typical eccentric joint in a timber truss (Brown’s River Bridge, Westford, VT, before its recent rehabilitation).	120
Figure 90. Three-dimensional image of computer simulation—unloaded. Note the short transverse elements at the truss lattice intersections that depict the trunnel connectors.	122
Figure 91. Three-dimensional image of computer simulation—distorted from load.	122
Figure 92. A heavy timber Burr arch—Wehr Bridge, Lehigh County, PA.	124
Figure 93. A lightweight arch attached only to the inside of the truss—Salisbury Center Bridge, Herkimer County, NY.	124
Figure 94. Large bolster beam supported on bearing blocks—Hall Bridge, Rockingham, VT.	125
Figure 95. A bolster formed of concrete—Village or Great Eddy Bridge, Waitsfield, VT.	125
Figure 96. Distribution beam system—Worral’s Bridge, Rockingham, VT.	128
Figure 97. No X lateral system and no knee braces—Comstock Bridge, East Hampton, CT.	130
Figure 98. An extremely strong upper lateral and knee brace system—Hamden Bridge, Delaware County, NY.	130

Figure 99. American Chestnut (allowable stresses are not in the NDS)—Comstock Bridge, East Hampton, CT.	132
Figure 100. Example of tensile failure of a bottom chord element in a World War II timber building.	133
Figure 101. Example of a tensile failure of a bottom chord in a covered bridge.	134
Figure 102. A horizontal shear failure—Mill Bridge, Tunbridge, VT, before its recent collapse due to ice floe impact.	135
Figure 103. Simple lap joint, with through-plane connectors.	138
Figure 104. Simple lap joint, with in-plane connectors.	139
Figure 105. Grain orientation of rectangular in-plane connector.	140
Figure 106. Lap joint with bypassing leaves and end grain bearing surfaces.	141
Figure 107. Lap joint with tapered halves and connectors.	142
Figure 108. Bolt-of-lightning joint.	143
Figure 109. Eccentricity in member layout and prying at connectors.	144
Figure 110. Eye-and-wedge clamping bolt, hand-forged.	145
Figure 111. A double-leaf lap joint, with through connectors.	146
Figure 112. Butt joint with steel fish plates.	147
Figure 113. Butt joint with fish plates—wooden plates.	148
Figure 114. Butt joint with bars and rods splice.	149
Figure 115. Simple lap joint for compression members.	150
Figure 116. Simple bearing joint at angled notch.	151
Figure 117. Top and bottom chord connections to vertical.	153
Figure 118. Truss vertical at bearing seat with critical shear face.	154
Figure 119. A sistered diagonal.	155
Figure 120. Example of pegs added to increase the shear capacity.	156
Figure 121. Long truss with counter timbers.	157
Figure 122. Town lattice trusses with identical versus mirrored web members.	159
Figure 123. Town lattice truss connections need to be inspected carefully.	161
Figure 124. Sistered lattice web at chord connection.	164
Figure 125. Built-up end post for a Town lattice terminated vertically—Paper Mill Bridge, Bennington, VT.	165
Figure 126. A solid-sawn end post—Fuller Bridge, Montgomery, VT.	166
Figure 127. An inclined end treatment—Bartonsville Bridge, Rockingham, VT.	167
Figure 128. The corresponding interior end post—Bartonsville Bridge, Rockingham, VT.	167
Figure 129. Intermediate posts—Worrall’s Bridge, Rockingham, VT.	168
Figure 130. Bearing blocks beneath the bottom chord where tails have been removed—Paper Mill Bridge, Bennington, VT.	169
Figure 131. Load sharing between arch and superimposed truss.	171
Figure 132. Tie beam to top chord connection.	172
Figure 133. A set of upper braces.	173
Figure 134. Added verticals at tie beams in Town lattice truss.	174
Figure 135. Tie beam to top chord connection details, first diagram.	175
Figure 136. Tie beam to top chord connection details, second diagram.	176
Figure 137. Tie beam to top chord connection details of failed joint.	176
Figure 138. Siding nailers spaced away from truss elements.	179
Figure 139. Fitch’s Bridge, Delaware County, NY.	181
Figure 140. Brown’s River Bridge, Westford, VT.	181
Figure 141. Racked two-span continuous bridge—West Dummerston, VT, before its recent rehabilitation.	184
Figure 142. Example of sag—Station Bridge, Cambridge, VT, before rehabilitation.	185
Figure 143. A chord butt joint in trouble—Station Bridge in Northfield, VT.	186
Figure 144. Field tests for deflection measurement comparison against computer prediction—Brown Bridge, Shrewsbury, VT.	190
Figure 145. Dial gauges used to measure the load response.	191
Figure 146. Three-element test specimen.	192
Figure 147. Tensile tests on lattice elements.	192
Figure 148. Replacement versus sister elements in Long truss—Downsville Bridge, Delaware County, NY, during its major rehabilitation in 1999.	194

Figure 149. Sister elements in Town lattice—Silk Road Bridge, Bennington, VT.	195
Figure 150. Sistered post repair in Long truss—Downsville Bridge, Delaware County, NY, during its major rehabilitation in 1999.	196
Figure 151. Partial post replacement in multiple kingpost truss—Union Village Bridge, VT.	197
Figure 152. Extra chord elements added to an existing Town lattice truss—Cedar Swamp Bridge, between Salisbury and Cornwall, VT.	198
Figure 153. Metal elements added to an existing bottom chord—Lincoln Bridge, Woodstock, VT.	198
Figure 154. An arch element added to a Town lattice structure—Scott Bridge, Townshend, VT.	199
Figure 155. A single bolt connects these single-piece arch segments to the truss post—Wehr Bridge, Lehigh County, PA.	200
Figure 156. Steel plates at heel connection of queenpost truss—Power House Bridge, Johnson, VT, before its collapse in 2001.	201
Figure 157. Spliced lattice tail replacements—River Road Bridge, Troy, VT.	202
Figure 158. Use of steel bolts in chord replacement—Kingsley Bridge, Shrewsbury, VT.	202
Figure 159. Installation of metalwork beneath a timber floor beam—Wehr Bridge, Lehigh County, PA. ...	203
Figure 160. Strengthening by using glue-laminated deck panels and floor beams—Hamden Bridge, Delaware County, NY.	204
Figure 161. Good siding details—Fitch’s Bridge, Delaware County, NY.	207
Figure 162. Good siding details around a window—Fitch’s Bridge.	208
Figure 163. Unfortunate approach grading directing drainage into a covered bridge—West Hill Bridge, Montgomery, VT.	209
Figure 164. Consequences of the poor entrance drainage in figure 163.	209
Figure 165. A trench drain at a bridge entrance—Fitch’s Bridge, Delaware County, NY.	210
Figure 166. Sacrificial timbers beneath truss elements.	211
Figure 167. Accumulation of debris and asphalt encasing timber elements.	212
Figure 168. Bridge at the Green, Arlington, VT.	215
Figure 169. Comstock Bridge, East Hampton, CT.	216
Figure 170. Museum at Shushan Bridge—Washington County, NY.	217
Figure 171. Brown Bridge, Shrewsbury, VT.	242
Figure 172. Lower Cox Bridge, Northfield, VT.	242
Figure 173. Side view of a typical covered bridge supported by Town lattice timber trusses. This is the Fuller Bridge, Montgomery, VT, during its recent reconstruction.	243
Figure 174. Depicts a portion of the bottom chords (upper and lower portions) of a Town lattice truss. The sections demonstrate the termination of one of the four chord elements at a given location along the truss.	244
Figure 175. Depicts the “rat’s nest” of wiring accompanying the installation of the 46 transducers. The equipment is shown mounted on top of the lower bottom chord element. The upper bottom chord element is in the foreground. The edge of the nail-laminated deck is shown along the right edge (a curb timber had been removed).	246
Figure 176. The temporary platform suspended beneath the bottom chords to enable access for strain gage installation. The siding was removed to facilitate the testing, but the bridge was scheduled to undergo a complete rehabilitation after the testing, which required siding removal for other purposes.	246
Figure 177. View of the Hamden Covered Bridge prior to work in 2000. Note the mid-span timber bent added in the 1970s to help support the sagging trusses. Also note the external top chord braces.	250
Figure 178. How NOT to relocate a covered bridge for repair work.	251
Figure 179. Successful relocation of the bridge using rollers on a false work system. The siding and roofing at the ends awaits final bearing installation.	251
Figure 180. A classic “Bolt-of-Lightning” splice. It relies on end bearing and shear to transfer the forces. The cuts include vertical mitering to allow the bearing blocks to settle into a tight fit, without falling out, should the joint tend to stretch.	252
Figure 181. One-hundred-thirty-foot- (39.6 meter) long one-piece bottom chords—monsters to fabricate and deliver and a handful to work with.	253
Figure 182. Internal bracing. It is certainly hard to pick out, but the major light-colored diagonal member is the Knee Brace. It is bolted to a lighter color Tie Beam and behind it with a Principal Rafter. The darker members are the original upper lateral system.	253
Figure 183. Diagonal to post connections at the top chord indicating significant overstress.	254

Figure 184. Wedges used in the connection between vertical post and chord—you have to look closely on the left side of the right post. In the writer’s opinion, their value is principally to distribute the high side-grain bearing stresses in the post to a larger area.....	255
Figure 185. Typical “folding wedges” of a counter. In this application, the main (glue-laminated) transverse member in the middle of the photo is the Floor Beam. The counter on the left bears against the wedges, then the Floor Beam against the side of the post.	256
Figure 186. Near final exterior view. Guide rail not yet installed and final seeding and mulch also not yet in place.....	257
Figure 187. Final inside view. Note the lighter-colored replacement members.	258
Figure 188. Start of work.	259
Figure 189. Deterioration at end.	260
Figure 190. Older “hung” floor.	260
Figure 191. Partially removed 1976 floor.	261
Figure 192. South Abutment prior to work.	261
Figure 193. North Abutment prior to work.	262
Figure 194. Longer trusses and new recess in existing abutment.	262
Figure 195. Reworked internal bracing system.	263
Figure 196. Partially installed deck.	264
Figure 197. Installing cedar shakes.	264
Figure 198. Siding details during installation.	265
Figure 199. Approach railing configuration at north entrance.	265
Figure 200. Elevation view of completed bridge.	268
Figure 201. View of south entrance and railing configuration.	268
Figure 202. Internal view of completed bridge.	269
Figure 203. As the bridge sat for 13 years.	272
Figure 204. Replacement top chords.	273
Figure 205. Hidden rot inside top of old post.	273
Figure 206. Bridge moved, but not down off temporary cribs.	274
Figure 207. View of shear dowel reinforcement.	274
Figure 208. Reconstructed east abutment.	276
Figure 209. Underway on dollies.....	276
Figure 210. On top of the bypass bridge—ready to be slid sideways.	277
Figure 211. Sliding sideways.	277
Figure 212. Bridge perspective view.	279
Figure 213. Typical bridge section.	280
Figure 214. Raising the trusses.	281
Figure 215. Hartland Bridge on the move.	283
Figure 216. Observers watching a bridge move past.....	284
Figure 217. Bridge in place awaiting final lowering.	284
Figure 218. Overall view of bridge showing overhanging portal, metal roof, outboard sidewalk, main truss, and arch visible through open side, and granite-faced abutment.	287
Figure 219. Main truss and arch during construction showing shouldered and wedged timber connections.	287
Figure 220. Underside of bridge showing floor beams, metal deck clips, bottom lateral bracing, arch springing area, and steel fabrication at the location where the arch passes through the bottom chord.	288
Figure 221. Final bridge.	289
Figure 222. Existing site with poor alignment.	289
Figure 223. New abutment construction on new alignment.	290
Figure 224. New stub abutment stem.	290
Figure 225. Truss assembly.	290
Figure 226. Three chord elements.	291
Figure 227. Adding siding before truss lifting and installation.	291
Figure 228. North truss in position and secured.	292
Figure 229. Both trusses erected.	292
Figure 230. Installation of roof trusses and purlins.	293
Figure 231. Installation of wood shingles.	293

Figure 232. Completed bridge.....	293
Figure 233. Original view.	295
Figure 234. Destroyed March 4, 1999.....	295
Figure 235. View in December, 2002.....	295
Figure 236. A view of the original bridge.....	296
Figure 237. Wooden peg reinforcement of post corbel.....	297
Figure 238. Reinforcement rod.....	297
Figure 239. Closeup of the failed corbel after the repair.....	298
Figure 240. Bar-and-rod connector tensile splice.....	298
Figure 241. Transition from approach rail to inside curb.....	299
Figure 242. Bridge being moved into position.....	299
Figure 243. Oxen power and capstan.....	300
Figure 244. Completed bridge.....	300
Figure 245. New pad at East Abutment—truss erection underway.....	301
Figure 246. Entrance of completed bridge.....	301
Figure 247. The bridge before work.....	302
Figure 248. Modified knee braces.....	303
Figure 249. Cranes and truck positioning the trusses.....	303
Figure 250. Bridge following reopening.....	304
Figure 251. Opening day parade.....	305
Figure 253. Bridge before collapse.....	305
Figure 254. Bridge after collapse from snow.....	306
Figure 255. Double bottom chord arrangement with scarf joint.....	306
Figure 256. Connection between deck and bottom chord.....	307
Figure 257. Heel connection details.....	307
Figure 258. Connection of tie beam, truss vertical, and rafter plate.....	308
Figure 259. Final product.....	308
Figure 260. Power house replica, Johnson, VT.....	311
Figure 261. Old Stone Fort Bridge, Schoharie County, NY.....	311

LIST OF TABLES

Table 1. Locations and dates of covered bridges by State	23
Table 2. Truss configurations—numbers and lengths.....	24

SECTION 1. BACKGROUND

- Chapter 1 Introduction
- Chapter 2 Covered Bridges: Form, Use, and Terminology
- Chapter 3 Historical Development of Covered Bridges



Figure 1. Chiselville Bridge, Sunderland, VT.

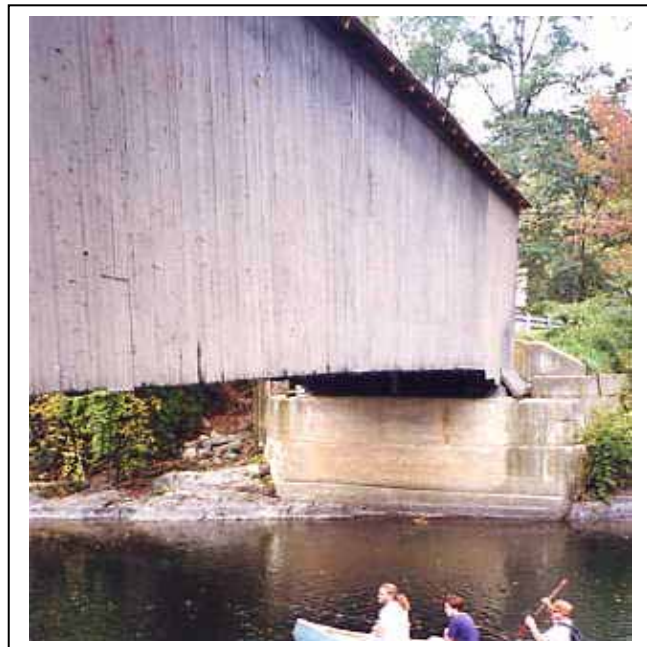

Figure 2. Eagleville Bridge, Washington County, NY.

Chapter 1. Introduction

Reference to a covered bridge often sparks an image of a quaint setting with a narrow, but inviting, timber tunnel crossing of a stream. For some, the image is of a more substantial structure crossing a raging river, withstanding the rigors of time and nature. At one time, the United States reportedly had 14,000 of these unique bridges dotting the countryside over a surprisingly large area. Now, fewer than 900 of the historic structures survive, and pressures grow to help preserve them from replacement, abandonment, vandalism, and arson. Federal funding over the past decade has grown to augment that of the States, owners, and others to find comprehensive and proven means of maintaining the ability of these vestiges of our bridge-building heritage to continue to serve current and future generations.

This manual is intended to provide comprehensive support to those involved with maintaining, assessing, strengthening, or rehabilitating covered bridges, especially heavy timber truss bridges. Although there are covered bridges throughout the world, this manual focuses on covered bridges within the United States. There is brief reference to those in other countries, primarily to provide a historical context of the development of timber truss bridges.

According to the *World Guide to Covered Bridges (World Guide)*, of the approximately 1600 covered bridges in the world, roughly 880 are in the United States.^[1] Even though there are many similarities among these bridges, no two were absolutely alike the day they were opened to traffic, and none have undergone identical use and maintenance to date. Therefore, even by limiting coverage to North American bridges, a fairly large and varied population is addressed.

This manual focuses on those covered bridges supported (or at least supported at one time) by longitudinal trusses built of relatively large (heavy) timber components. This manual deals only with covered bridges, and not with those bridges that are covered. The former describes a structure that earns its keep—one that is as it appears to be—an authentic covered bridge. The other, so-called covered bridges (usually girder-supported bridges with some sort of shed on top) just happen to support a roof and walls, and are not generally considered legitimate covered bridge structures.

Figure 3 shows a classic historic covered bridge—the Taftsville Bridge in Woodstock, VT. This two-span bridge, supported by unique trusses with heavy arches, was built in 1836, making it one of the older covered bridges in the United States.

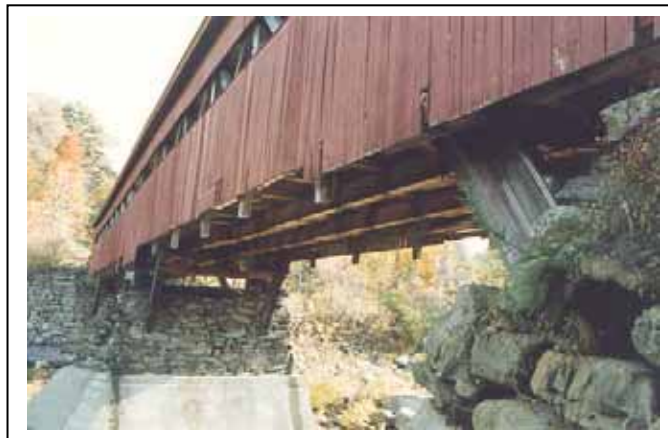

Figure 3. A classic historic covered bridge, the Taftsville Bridge, Woodstock, VT

Some authentic covered bridges have been retrofitted to remove their timber floor system and replace it with an independent system. The remaining timber-framed covering must still support its own weight, along with wind forces, and potentially snow. This manual does not separate these retrofitted structures from other authentic complete bridges; –the discussion can deal with either, and will be useful in establishing ways to evaluate the timber trusses and means of maintaining and/or rehabilitating them.

Information is culled from both readily and not-so-readily available references. Because little has been written about the technical aspects of covered bridges, information is provided based on both the experience and expertise of the authors. It is worth noting that some of the information in this manual represents opinions regarding best practices, even though these practices may not be commonly or widely accepted.

The content of this manual is strongly influenced by the Principal Investigator’s involvement in the comprehensive statewide study of 75 covered bridges in Vermont. The work, was performed by a consulting firm under contract to the Vermont Agency of Transportation, and was concluded in 1995. The study involved preparing a long-term preservation plan for each bridge based on the condition of the bridge and the traffic needs at the site. The team responsible for this manual has had firsthand hand engineering involvement on more than 110 bridges in many States. The population of covered bridges in the United States is diverse, in large part due to the nature of their construction. Few builders traveled long distances and features favored by one builder were different from those in another area. Hence, this manual presents a comprehensive discussion of the multiple facets of covered bridges, but cannot include all aspects.

While many of the references are useful in covering several topics, they will be introduced with each topic. Some very general and useful references are cited throughout the manual. The most pervasive background sources, specific to their specialized topics, are:

For bridge specifications—*Standard Specifications for Highway Bridges*, as adopted by the American Association of State Highway and Transportation Officials (AASHTO).^[2] These specifications were published first in 1931 and have been modified and expanded regularly. The latest edition of these specifications is the 17th edition of 2002. Chapter 9 of this Covered Bridge Manual clarifies some of the confusion regarding the differences between the AASHTO “Standard Specifications” versus the “Load and Resistance Factor Specifications” as they relate to covered bridge practice.

For timber specifications—*National Design Specifications for Wood Construction* (NDS[®]) and its *Supplement: Design Values for Wood Construction*, published by the American Forest and Paper Association.^[3] These specifications were published first in 1944 and have been modified and reissued regularly ever since. The most recent edition was published in 2001. The NDS, is commonly cited and is the basis of timber-related provisions published by other organizations (including the AASHTO bridge specifications), is commonly cited.

For an excellent overall reference regarding timber bridges is—*Timber Bridges Design, Construction, Inspection, and Maintenance*, published by the U.S. Department of Agriculture, U.S. Forest Service.^[4] The latest reprinting is 1990.

For a comprehensive listing of covered bridges, with a synopsis of relevant information concerning them, see the *World Guide*, published by the National Society for the Preservation of Covered Bridges, Inc.^[1] First published in 1956, the latest edition is 1989. A new edition was under development as of 2004.

The manual is primarily intended for engineers and historic bridge preservationists to provide technical and historical information on preservation of covered bridges. However, it will also be of interest to others involved with covered bridges, including the lay persons, owners who may have some knowledge on the topic, or contractors involved with covered bridges. Accordingly, the presentation style is somewhat modified, depending on the topic and perceived audience.

The manual is separated into several sections with a number of chapters devoted to the specifics of each. The first three chapters provide background information. The typical covered bridge is described, along with its setting and terminology. Some general facts and statistics are provided. A brief historical development is included to help explain how timber bridges evolved and spread across the United States.

The description of bridge components section provides descriptions of the various truss configurations, discussions of the floor systems of the bridges, the various ancillary features that supplement the primary features of trusses and floor, and a discussion of the foundations that support the bridge.

Technical engineering issues begins with a short chapter that explains some of the unusual challenges of work with covered bridges and why their engineering is different from that for other bridges. Other chapters are devoted to guiding specifications; clarifications of topics related to wood; loads and the increased importance of the weight of the structure and the special handling of snow in combination with vehicular traffic; nuances related to forces, stress analysis and design; and a lengthy discussion of connections.

The existing bridges section is the heart of this manual. The first chapter of this section is devoted to evaluating a bridge. The next chapter provides a discussion of repair and strengthening of bridges, along with examples of three recent projects. The following chapters include a guide for preservation actions and a summary of historic considerations related to this type of work. A comprehensive state-of-the-art guide for preservative treatment of wood in covered bridges is presented as the last technical chapter.

The final chapter provides a list of references and other sources of information.

The appendices include case studies that provide more indepth examples of repair and strengthening of extant bridges. Examples of recent authentic-type construction at new sites and replica bridges intended to generally duplicate a destroyed bridge, are also included as appendices in this manual. The growing number of new covered bridges warrants inclusion in this manual, because many of the same issues are relevant to them as for historic bridges are also relevant to new bridges.

Chapter 2. Covered Bridges: Form, Use, and Terminology

The “Typical” Covered Bridge

To gain the most from the use of this manual, one begins with the basic definition of a covered bridge. For the purposes of this manual, a covered bridge is a timber structure supporting a deck surface that carries loads over an obstruction (e.g., a river). A covered bridge’s structural components are protected from the elements by various coverings: walls, roofs, and decks. Figure 4 depicts a classic example of a covered bridge.

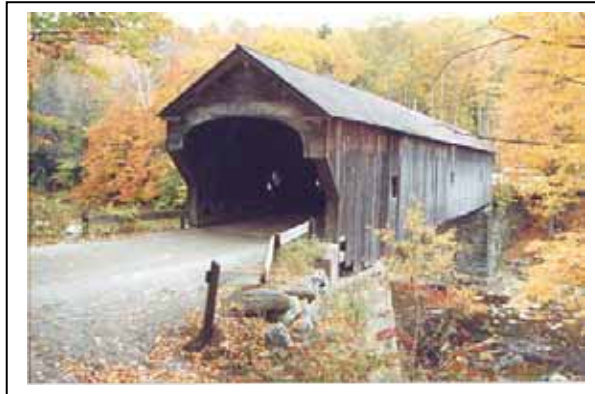

Figure 4. Typical covered bridge, Upper Falls Bridge, Weathersfield, VT.

The typical covered bridge uses heavy timber trusses to carry loads over an obstruction. The floor system spans between the longitudinal trusses, and distributes and carries the loads between those trusses. The bridge is completed by lateral bracing (elements that connect each truss, or side, of the bridge), a wall system, and roof intended to prevent weathering. The roof’s primary function is to protect the structural timbers from the ravages of intermittent wetting. In bridge engineering terms, this style of structure is termed a through truss.

Some timber truss spans have deck surfaces exposed to the weather, with only the longitudinal trusses sheathed in by two walls and a very narrow roof—a style traditionally termed a pony truss or half-through truss. Figure 5 shows one of these especially rare remaining pony truss covered spans, the Comstock Bridge in Connecticut. The bridge is closed to vehicular traffic. As seen in the photograph, a covering a pony truss hides all details of the truss from view.



Figure 5. Pony truss covered bridge, Comstock Bridge, East Hampton, CT.

Many popular explanations have been offered for covering the bridge, but the simplest (and most common) reason was to preserve the supporting timbers. Timber bridges initially were built without coverings and failed in just a few years because of rot and deterioration, because chemical wood preservatives were not available or used. Builders familiar with the construction of houses, barns, and large community structures naturally added siding and roofs to help protect the bridge. They understood that the covering would soon pay for itself. They believed that regular maintenance and occasional replacement of the light covering was far easier and cheaper than building an entirely new bridge. North American covered bridges still serve after nearly 200 years, due in part to the continued soundness of the trusses, which was possible only with these protective coverings.

In addition to the floor, side-supporting trusses, roof, and siding, internal bracing is required to maintain the intended geometric shape and capacity of the structure. Bracing enables the structure to resist lateral load from wind and remain straight along its sides and square, thus enabling the structural components to support their greatest loads.

The Typical Setting

Vehicular Loading

Covered bridges have been built in many different situations and in widely varied settings. However, the focus of this manual is on the most common surviving covered bridge—one intended to provide for vehicular loads, originally carriages, carts, and wagons, but now automobiles, trucks, and motorcycles.

There used to be many covered railroad bridges, but only a few still remain in the United States. According to the *World Guide*, there are only eight North American railroad covered bridges still standing. There may be others, but these are the ones observed in the guide.

1. Bridge 29-05-14 Clark/Pinsley Railroad over Pemigewasset River, Grafton County, NH, occasionally open as tourist line.
2. Bridge 29-07-07 Contoocook Railroad over Contoocook River, Merrimack County, NH, closed to traffic.
3. Bridge 29-07-09 Sulphite Railroad over Winnepesaukee River, Merrimack County, NH, closed to traffic.
4. Bridge 29-10-03 Pier Railroad over Sugar River, Sullivan County, NH, closed to traffic.
5. Bridge 29-10-04 Wright Railroad over Sugar River, Sullivan County, NH, closed to traffic.
6. Bridge 37-20-40 Chambers Railroad over Coast Fork of the Willamette River, Lane County, OR, closed to traffic.
7. Bridge 45-01-05 East Shoreham Railroad over Lemon Fair River, Addison County, VT, closed to traffic.

8. Bridge 45-08-16 Fisher (Wolcott) Railroad over Lamoille River, Lamoille County, VT, occasionally open as tourist line.

Unfortunately, none of these bridges is still in regular service; all, have been abandoned or converted to other uses. The bridges at Clark's Trading Post in New Hampshire and the Fisher Bridge in Vermont serve an occasional tourist shortline. The very heavy loads of the railroads were sustained only through extraordinarily strengthened truss configurations. Lattice truss bridges were often doubled, using two vertical trusses instead of one. Other trusses (Howe trusses were popular for railroads) were strengthened by a variety of means. This provided the capacity for what remain the heaviest common design loads. Much of the material contained within this manual would apply to these few remote and unraveled spans.

Water Crossing

The great majority of the original and surviving covered bridges crossed streams, usually with a single span. Many of the first crossings of the major Eastern rivers were accomplished with multiple span covered bridges. (The record, at 1,735 meters (m) (5,690 feet (ft)) long, was erected across the Susquehanna River between Columbia and Wrightsville, PA). However, the heavy traffic loads and wildly fluctuating water levels made for relatively short lifespans for those magnificent bridges. In addition, the close proximity of the covered bridge to water caused special problems related to accelerated deterioration due to rot, as well as the ever-present danger from floods.

Vehicle Opening

Almost without exception, covered bridges were built to carry only a single, narrow lane. Most covered bridges were built at naturally narrow spots in the stream, and at right angles to the flow, to minimize the span length. This means that many covered bridges, which were built for much slower moving traffic than most modern automobiles, have at least modest curves at both ends of the bridge. These common existing bridge geometries—single lane and sharp curves at the ends—are both curses and blessings. The problem is that the geometry is often enough out of tolerance with modern traffic to make the covered bridge functionally obsolete; this is the main reason . More bridges have had to be replaced because of this than any other reason. On the positive side is the fact that these same geometries have contributed to the spans' longevity. The single-lane bridges limited the load carried on the structure at any one time. The sharp curves slowed traffic, thereby reducing the extra effect of the impact of bouncing vehicles. Slower speeds also reduced the number of accidents, which might have harmed the bridge. What was acceptable for horse-drawn vehicles, however, is sometimes not tolerable for cars and trucks.

Single-lane bridges are also far more likely to be well- proportioned than doublewides. A few 20th-twentieth century covered bridges have two-lane- wide, undivided roadways, rather than. They do not have the classic proportions that make many older covered bridges so photogenic and popular. The designers also had trouble spanning between the trusses, because the floor systems tend to be very heavy.

In a very few instances, the original builders needed to plan for two-way traffic to avoid the delays inherent in sharing use of the bridge. Today, according to the *World Guide*^[1], only six remaining covered bridges provide this double-barrel capacity. These bridges have an added central, third truss. The center truss avoided extra long and substantially deeper floor beams, and separated opposing traffic flows. Furthermore, this central and more heavily loaded truss was often built deeper to take advantage of the pitch of the roof, thereby gaining additional strength and stiffness.

Another issue related to vehicle opening is the restricted vertical clearance. Most historic covered bridges have limited vertical clearance that prevents taller loads from passing through the bridge. This restriction has helped prevent some heavier vehicles from causing weight-related damage to the bridge. Unfortunately, it is common to find damage to the portals of covered bridges caused by attempted passage of overheight vehicles. This restricted vertical clearance contributes to the functional obsolescence of the bridge according to modern measures.

Component Terminology

Figures 6 and 7 depict the technical terminology used with covered bridges. Many of the same terms used are common among covered bridges and other metal trusses, yet there are some terms that are unique to covered bridges. Further, some terms historically have been applied to covered bridge components in ways that are not necessarily compatible with similar components of metal trusses. Figure 6The following provides the terms as typically used in covered bridge work.

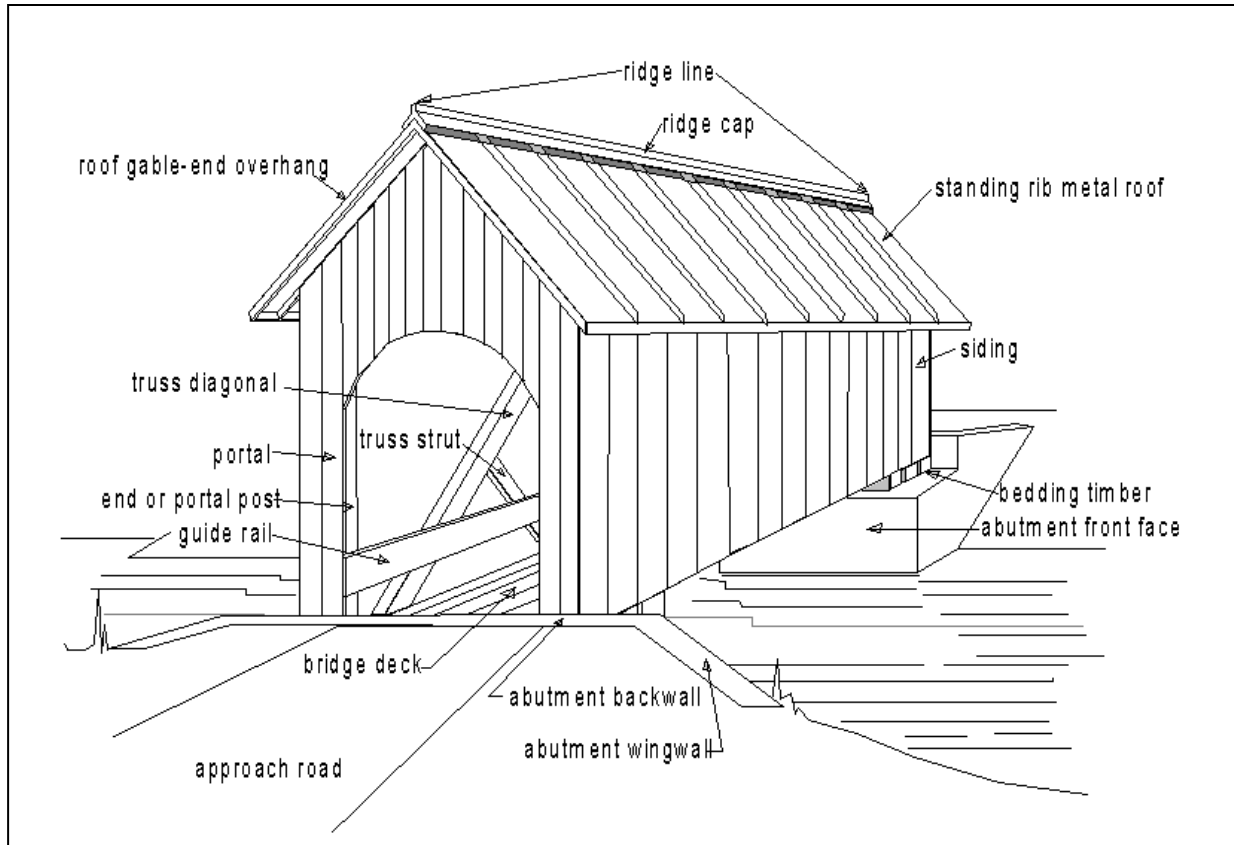

Figure 6. Bridge diagram—general terminology.

The longitudinal trusses are the backbone of the bridge. There are numerous configurations for these principal elements, and they are discussed in chapter 4. For the purposes of this overview, the primary trusses all contain three main components—a top chord, a bottom chord, and web members. A truss is a beam with a latticed web. As a beam has strength from its bending resistance, the structural capacity of any truss relies on the principal members resisting axial forces, —forces that act along the longitudinal axis of the component. These axial forces are either compression or tension.

Those members that run longitudinally along the top and bottom of the truss are termed chords. The upper, or top, chords are in compression. The bottom, or lower, chords are in tension. (This simplified characterization is intended for the most common single-span covered bridge. Those very few covered bridges that have continuous spans behave in a different way to reverse the forces in the chords, depending on location along the span, —a clarification that probably is not warranted for this purpose.) These chord members in a given truss can be of a single piece (say, the full length of the bridge) or spliced. The chord members also may be built of multiple pieces, in cross section.

The vertical and diagonal truss members between the upper and lower chords that prevent those chords from moving relative to each other are called web members. These same members provide the transfer of vertical loads along the span to the supports at the ends. Some of these web members will usually be in compression; others will consistently be in tension.

Depending on the truss type, and their location within the truss, the diagonal web members may have special names, such as the end post, main diagonal, counter, or brace. The vertical elements are termed posts or verticals. The portion of the truss between verticals and diagonals is termed a panel. Figure 7 illustrates the truss components for a modified queenpost truss. Other configurations use similar terminology.

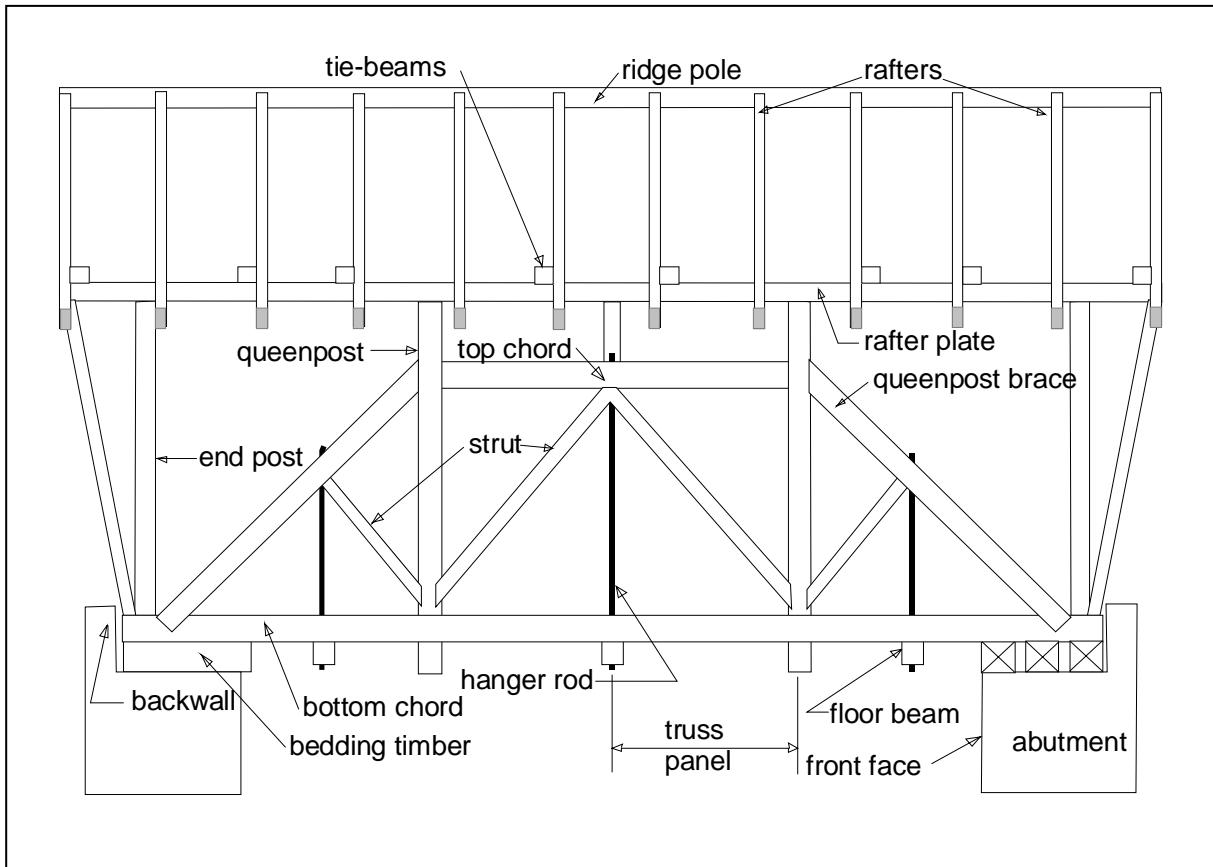

Figure 7. Diagram of queenpost truss—general terminology.

Most heavy timber trusses violate two basic modeling assumptions made in analyzing simple trusses. First, many chord and web members are continuous through some connections and not pinned at every truss joint. Second, many of the truss joints are detailed, with some eccentricities in member centerlines. Both of these variations from classic truss analysis theory mean that the truss members will also be resisting shear and bending forces, sometimes significant ones, particularly near the truss connections.

Covered bridge floor systems are configured in a number of ways but, in general, their heaviest members span between the trusses and are known as floor beams. There may be other members, supported on top of the floor beams that are aligned parallel to the bridge. These lighter members are termed stringers. The longitudinal stringers are sometimes referred to as joists, after their similarity to flexural members in building construction. In this manual, they will be referred to as stringers.

There is no clear separation between those bridges with stringers versus those without—virtually any type of truss configuration can support a floor beam and stringer system. Those with stringers have floor beams spaced farther apart—up to 3.0 to 3.7 m (10 to 12 ft). Figure 8 presents an example of a floor system with stringers supported by widely spaced floor beams. The floor beams in these types of bridges are, therefore, much heavier than those found in bridges with far more, but lighter, floor beams. An example of a floor system with closely spaced floor beams but without stringers is presented in figure 9.

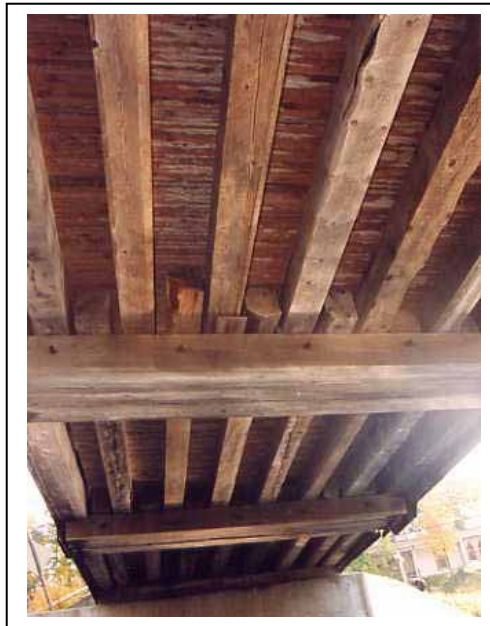

Figure 8. Floor system with stringers and floor beams—Warren Bridge, VT.



Figure 9. Floor system with floor beams, but without stringers—Hutchins Bridge, VT.

The uppermost structural layer, termed the decking, directly supports the vehicle wheels and transfers their load to the stringers or floor beams below. The decking rests on the stringer or floor beam. On occasion, there is more than one layer of deck planks;—as many as three is a common configuration.

If there are few, but heavy, floor beams, the stringers span between them and are spaced close enough to support the decking. These bridges have transverse (side-to-side) decking. In contrast, if there are many, lighter floor beams, the decking itself can span between the floor beams. These bridges, as a result, have longitudinal decking. In both cases, these bridges may have yet another layer of floor boards,

running longitudinally, often termed running planks, or simply, runners. These are the actual wearing surface on which vehicles travel. These boards are like a wearing surface on a concrete deck, and sacrificial; i.e., they can be replaced when badly worn. Figure 10 shows an example of running planks. In this case, the top layer of deck planks run transversely (there are bottom planks spanning longitudinally between closely spaced floor beams).



Figure 10. Running planks–Hutchins Bridge, VT.

In a traditional covered bridge, the floor components, or decking, are all timber and may be in one or more layers. Many bridges have been repaired by using other materials, including steel stringers, concrete slabs, or even steel grating. There could be a layer of asphalt on top of the decking to provide some additional skid resistance, better traction, and increased durability.

Next in the discussion of bridge terminology is the lateral bracing system. These members help keep the structure both straight and square, and prevent twisting and torsion. The bracing installed in a horizontal plane at or immediately above the upper chord level is usually referred to as upper lateral bracing. Some people will refer to these elements as diagonal bracing. This description is ambiguous, however, because the web members of the main trusses include diagonals in the vertical plane of those trusses. The upper bracing includes members that span transverse to the axis of the bridge—these are termed tie beams (the preferred term used hereafter), or more properly struts (in structural engineering terminology, struts can support either compression or tension). The members that cross between the trusses, and that are connected to the ends of these tie beams, may be termed diagonals, cross bracing, or laterals. The preferred term is lateral braces. This system of tie beam and lateral bracing transfers the lateral wind loading on the upper half of the bridge along the span to the portal framing and then to the abutments. The lateral bracing system provides the resistance against wind loading and helps the top of the bridge to remain straight along its axis.

Figure 11 provides an example of an upper lateral bracing system. Looking closely, one can see this builder's use of a very unusual fish configuration of the laterals as they widen along the bridge and cross at both ends. The tie beams are supplemented with a center post that supports the ridge beam. The rafters are quite widely spaced with solid roof boards. The knee braces are short diagonal members mortised into the underside of the tie beams and the front face of the vertical posts.



Figure 11. An unusual upper lateral system—Seguin Bridge, VT.

Some covered bridges also contain a lower lateral bracing system below the floor that is configured similarly to the top lateral bracing. It is called the bottom lateral system or lower lateral bracing. Bottom lateral bracing systems usually consist of diagonal members, connected to the ends of the floor beams. This system resists lateral movement of the bridge and helps to resist wind loading. Town lattice truss floors were often built with more closely spaced floor beams—so close, in fact, that a lower lateral system was not installed. However, for other configurations of trusses, a lower lateral system commonly was installed during the original construction. Subsequent floor replacements may have eliminated the lateral system, because unlike the upper level, where there is no other major component to replace it, the floor of the bridge can serve the same function. Even when the bottom lateral bracing is included, it shares lateral loads with the decking. Depending on how the decking is installed, its relative stiffness against lateral loads may mean it carries the majority of any lateral loading. If the bridge does not have bottom lateral bracing, a temporary bracing system should be installed during redecking operations. (Refer also to the related, more technical discussion of bracing in chapter 6 regarding the need to restore missing lower lateral bracing). An example of lower lateral bracing system is shown in figure 12. This nail-laminated deck is supported by transverse floor beams in a T Town lattice truss structure.



Figure 12. Lower lateral system—Williamsville, VT.

Finally, there are components that help to keep the bridge cross section square along its length. These short diagonal members are located in the upper corners of the bridge at regular spacing. In relation to their counterparts in metal trusses, they are termed knee braces (the preferred term and used hereafter). More colloquial terminology of covered bridges uses the term wind brace or sway brace (not to be confused with the overhead transverse frames in a metal truss). They usually connect the tie beam to the web members of the truss. These knee braces can also transfer lateral loads down, from the roof to the deck, if the deck level lateral system is much stiffer than the upper level lateral bracing system. In any event, these relatively small members can play very significant roles in holding the covered bridge in line. Of all structural members, they are also among the most vulnerable of the structural members to traffic damage. The covered bridge traffic aperture is constrained. When rehabilitating bridges for modern traffic, many methods are used to provide this aperture bracing while maintaining maximum overhead clearance when rehabilitating bridges for modern traffic.

Figure 13 depicts very unusual knee braces made from the juncture of tree root and trunk, modeled after those used in old ships. In this case, the knees of the bridge are prone to being struck by larger vehicles, and these knees present less intrusion into the lane while still providing a strong connection between tie beam and truss vertical.

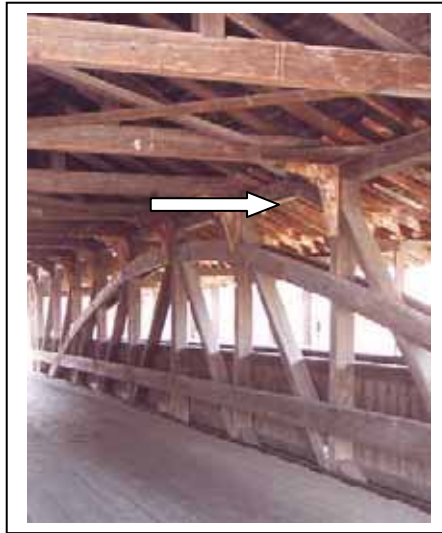

Figure 13. Unusual ship knee braces—Village or Great Eddy Bridge, in Waitsfield, VT.

Covered bridges also include a set of more ancillary components. The roof is comprised of rafters, just as in a house. The rafters are usually spaced closely enough that light sheathing boards can span longitudinally between them. The rafters may be connected at their midheight with horizontal rafter struts, whose function is to help stiffen the occasionally undersized rafters against sag. If these collars are under a lot of compression, their connections to the truss tops must be able to resist the added outward thrust. Those trusses, in turn, must be connected to each other well enough through the roof struts to resist the outward thrust at the roof eave level. There may be a longitudinal ridgepole or board at the peak, into which the rafters frame. Only very rare covered bridges had heavier structural longitudinal ridge beams in their roof systems. These heavy ridges had to be supported on roof struts that were stout enough to handle the bending from the weight of the ridge beam conveyed to the center of the strut via a vertical post (refer back to figure 11 for such an example).

Some bridges have an upright transverse frame that extends above the tie beam level and stiffens the roof system against distortion. This unusual lateral bracing system has been called various names, and there is no specific bridge-related terminology. It can be referred to as an upper wind frame (also shown in figure 11).

The bridge siding sometimes wraps around and continues on the inside of the trusses at the ends of the bridge, sometimes as far as 2.4 to 3 m (8 to 10 ft). This portal siding protects the end truss members from windborne rain and from the splash of water from entering vehicles. This siding is identified by various terms, including interior end siding, false door, or more commonly, shelter panel. The shelter panels can be of two types: —boarded over a short distance of the inside of the trusses, or as a separate structural extension beyond the ends of the trusses.

Figure 14 provides an example of a shelter panel that involves boards covering the end of the truss. Figure 15 shows an example of an end shelter panel separate from the truss. Figure 16 shows the overall framing of this end of the bridge before the completion of the siding and roof.

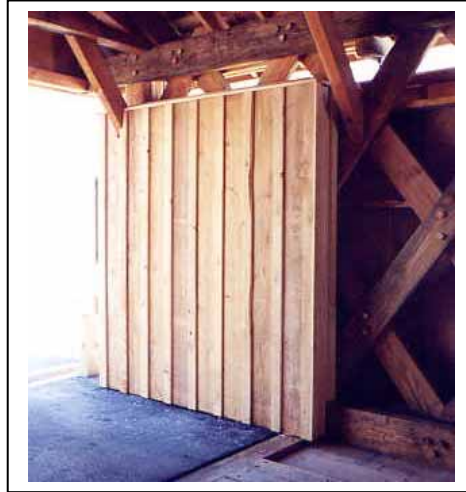

Figure 14. Shelter panel covering of truss ends—Fitch's Bridge, Delaware County, NY.



Figure 15. A shelter panel separate from the trusses—Hamden Bridge, Delaware County, NY.



Figure 16. Framing of the independent shelter panel—Hamden Bridge, Delaware County, NY.

The ends of the bridge are called portals and include the siding above the entrances to the bridge (they are the entrance to any bridge with overhead bracing). Portals are areas that typically contain any distinctive decorations on the bridge; they may include some fancy finish work. On some bridges, various regulatory signs, such as height, width, or load restrictions, are placed on the portal.

Following is a description of the bridge's foundations, those components that support the bridge—its foundations. The foundations at the end of the bridge are termed abutments. Any intermediate foundations are called piers. (Refer to figure 17 for terminology.) Most original multiple-span covered bridges were simple spans, framed separately but in line. Some Town lattices were originally continuous. Other covered bridges have intermediate piers (both permanent and long-term temporary) that were added to strengthen or to simply reinforce what had been a simple span. Some of these added piers are both well-intended and well-done. Others are just well-intended, albeit necessary. Most original foundations were constructed of stone, with or without mortar between the stones. More modern foundations, or in most cases, more recent rehabilitations, may have included reinforced concrete, cast either in front of the stone or in place of the original stone. The comparison of the economy and durability between concrete and stone is debatable; however, stone is often cited as much more aesthetically pleasing.

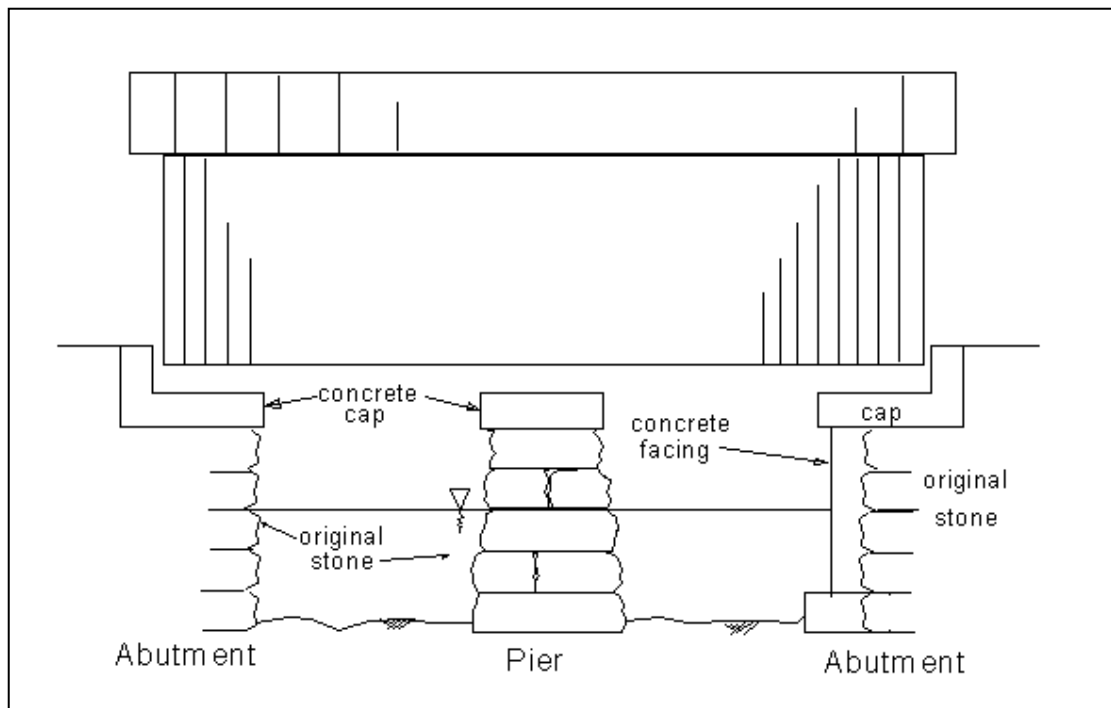

Figure 17. Foundations.

There are usually a number of small timber components between the foundation material and the underside of the main truss components. These timbers are labeled by a number of different terms, including bedding timbers, bearing timbers, or bearing blocks. These shorter timbers, placed at right angles beneath the chords, are intended to be sacrificial and readily replaced, if and when they rot and deteriorate, thereby preventing deterioration in the main truss components. In some bridges, these timbers are longer (placed parallel to, and below, the bottom chord) and extend out beyond the face of the foundation, where they support the main truss members. These longer timbers are often termed bolster beams, because they help support the bridge by effectively shortening the clear span. Figure 18 shows an example of bolster beams—the large timbers positioned directly beneath the bottom chords and above the concrete cap, jutting out beyond the front face of the cap. The two longitudinal timbers below the floor beams and between the bolster beams are distribution beams.

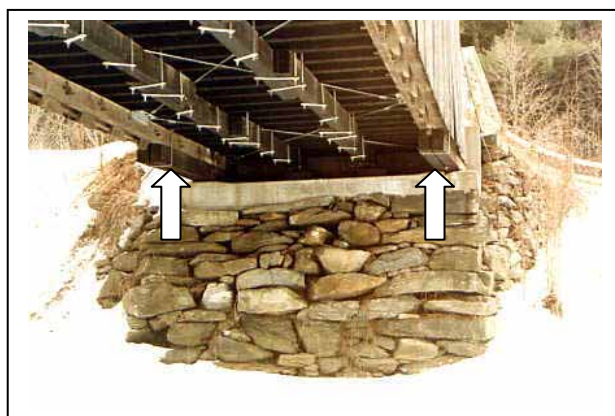

Figure 18. Bolster beams—Worrall's Bridge, Rockingham, VT.

Facts about Covered Bridges

Covered bridges have been around long enough and have been built in so many forms that they have accumulated a trove of oddities.

The National Society for the Preservation of Covered Bridges has, since 1956, periodically published the *World Guide*, beginning with the first edition in 1956.^[1] The most recent edition was printed in 1989, and the next edition is being prepared. Although not error-free, the *World Guide* provides the only available comprehensive documentation of the world's covered bridges. The information contained in this section of this manual is intended for general interest regardless of any errors contained here. It is not intended to end arguments, nor start new ones. It is intended to help the reader gain perspective about covered bridges in the United States.

There are 880 covered bridges listed in the *World Guide*^[1] that are located in the United States. About 810 of them (according to J. Conwill, major contributor to the 1989 edition) could be described as authentic, according to this manual's definition. Given the loss of covered bridges to arson, flood, and neglect, this number is decreasing. However, new and authentic covered bridges are being built occasionally, so the total number is a moving target. In effect, then, there are nearly 900 covered bridges in the United States. Analysis of the covered bridge population database reveals the following.

Oldest Covered Bridge in United States

There is much controversy about the age of older covered bridges. In this regard, the *World Guide* is considered quite misleading, with many unsubstantiated dates. According to Conwill, there are three with authenticated dates before 1830.

- Hyde Hall Bridge in Oswego County, NY, circa 1825.
- Haverhill-Bath Bridge at Woodsville, NH, circa 1829
- Roberts Bridge in Preble County, OH, built in 1829.

Whatever their precise construction dates, these are old bridges—much older than any made of steel or concrete. Only stone arches predate covered bridges in the United States.

It is also interesting to examine the geographic distribution of the contenders for the oldest remaining covered bridge title. As one would expect, the oldest bridges were built in the Middle Atlantic and New England States. One might expect to be able to track the migration of covered bridges across the States, with the West Coast being the last region to build covered bridges. It is very possible, if not probable, to

use the available information for the remaining bridges to draw misleading conclusions about this potential spread of technology. However, covered bridges were built in California long before they appeared in many of the intervening States (as early as 1862). This may well reflect the leapfrog of population that followed the California Gold Rush, as well as the availability of large timbers in the West.

Another classification of the covered bridge distribution involved the decade of original construction. Of the 880 surviving bridges, 195 were built between 1870 and 1879, and 149 more were built between 1880 and 1889. Covered bridge building continued to decline steadily, to a low of seven surviving examples that were built between 1940 and 1949, and only five from 1950 to 1959. More than a dozen were built in each decade of the 1960s, 1970s, and 1980s, which shows a recent resurgence in their popularity.

Length

To understand this category, a brief discussion of measuring a bridge's length, or span, is necessary. Many conventional bridges have a fairly well-defined support point, with distinct bearing between the foundation and the superstructure of the bridge. The distance between the centers of these bearing points establishes the bridge's span or length—an important feature related to the design and/or determination of the capacity of the bridge. However, conventional bridges also tend to incorporate very limited structure outside these clearly defined bearing points. A single-span steel girder bridge, for example, with 30.5 m (100 ft) between the centers of the end bearing points, might be built with girders that are only 31.1 m (102 ft) long.

Even if the end of the bridge is difficult to clearly identify, there is usually a joint in the roadway surface to allow expansion and contraction with thermal effects. Therefore, when measuring the span of a conventional bridge, one can determine both its span length and total length without much controversy.

Covered bridges, in contrast, do not usually contain a single and clear bearing point between foundation and superstructure. Instead, there may be a number of timbers that help transfer the load from the bridge trusses to the foundations. This transfer occurs over a distance that could be several feet at each foundation. Furthermore, the portal framing can extend fairly far out onto the abutments, in the interest of increased protection to the vulnerable and heavily loaded end timbers. These end conditions often have made it difficult to clearly establish the span length for many covered bridges. A dimension that is sometimes substituted is the distance between abutments.

These end conditions can create big differences between the face-to-face of abutment dimension and the readily perceived overall length of the bridge's apparent superstructure. To further complicate the situation, some span measurements have included the length of the roof overhang at the portals in the length of the bridge, while others do not.

The Bridgeport Bridge in Bridgeport, CA, built in 1862, has the longest recorded structure length, at 71.0 m (233 ft). The second longest bridge is the Blenheim Bridge in Schoharie, NY, built in 1855, at 69.5 m (228 ft). However, the Blenheim Bridge has the longest distance between abutments at 64.0 m (210 ft) (see figure 19). A classic historic covered bridge, the Blenheim Bridge is supported by long trusses supplemented with arches. It is one of the very few surviving double-barrel bridges. Many authentic covered bridges were built with clear spans greater than 30.5 m (100 ft).



Figure 19. Blenheim Bridge—longest clear span in the United States.

Locations

Many people associate covered bridges only with New England and a very few other States. Interestingly, there is at least one covered bridge still standing in 30 States. Pennsylvania has, by far, the most, with 227 surviving examples. This is followed by Ohio, with 143; Vermont, with 100; and Indiana, with 93. Those States with only one surviving, authentic covered bridge are: Minnesota, Mississippi (this bridge's authenticity has been questioned), New Jersey, and South Carolina.

Table 1. Locations and dates of covered bridges by State*

State	Number	Ranking	Earliest	Latest
Alabama	14		c1850	1934
California	13		1862	1984
Connecticut	5		1841	1976
Delaware	2		c1870	1870
Georgia	17		c1840	1975
Illinois	9		1854	1987
Indiana	93	4 th	1838	1922
Iowa	12		1869	1969
Kentucky	13		c1835	c1925
Maine	12		1857	1990
Maryland	6		c1850	1880
Massachusetts	17		1832	1985
Michigan	6		1832	1980
Minnesota	1		1869	
Mississippi	1		1966	
Missouri	5		1868	1980
New Hampshire	57	5 th	1827	1987
New Jersey	1		1866	
New York	29	7 th	1823	1982
North Carolina	5		c1860	c1910
Ohio	143	2 nd	1829	1986
Oregon	51	6 th	1914	1989
Pennsylvania	227	1 st	180_	1988
South Carolina	1		1909	
Tennessee	6		1876	1977
Vermont	100	3 rd	c1820	1982
Virginia	9		c1800	1920
Washington	6		1905	1976
West Virginia	17		1852	1911
Wisconsin	2		1876	1962
30 States	880			

*From the *World Guide to Covered Bridges*^[1], published by the National Society for the Preservation of Covered Bridges, 1989 edition. The caveat about dates cited in the table is explained more thoroughly in a previous section of this chapter, "Oldest Covered Bridge in the United States."

Types of Supporting Trusses

According to information provided in the *World Guide*, the 880 surviving covered bridges are supported by 18 distinct truss configurations, and multiple variations thereof. (Chapter 4 contains a description of each of the truss configurations.) The Burr arch is by far the most popular, with 224 surviving examples. The Howe truss is used in 143 bridges, followed by 135 Town lattice bridges, 101 queenpost truss bridges, and 95 multiple kingpost truss bridges.

Table 2. Truss configurations—numbers and lengths*

Truss Configuration	Number	Title	Single Span Length ("L") Without Variations				Ranking
			Shortest		Longest		
			feet	meters	feet	meters	
Brown	2		100	30.5	116	35.4	
Burr	224	and variations	32	9.8	222	67.7	1 st in L
Childs	7		50	15.2	104	31.7	
Haupt	2	and variations	85	25.9	134	40.8	
Howe	143		20	6.1	200	61.0	2 nd in L
Inverted bowstring	2		75	22.9	100	30.5	
King	30		22	6.7	70	21.3	
Long	27		51	15.5	170	51.8	5 th in L
Multiple king	95	and variations	36	11.0	124	37.8	
Paddleford	10		35	10.7	120	36.6	
Paddleford arch	11		78	23.8	183	55.8	3 rd in L
Partridge	6		64	19.5	154	46.9	
Post	1		165	50.3		0.0	6 th in L
Pratt	8	and variations	36	11.0	96	29.3	
Queen	101	and variations	25	7.6	130	39.6	
Smith	20		59	18.0	172	52.4	4 th in L
Tied arch	4		37	11.3	136	41.5	
Town	135		25	7.6	162	49.4	7 th in L
Town and supplemental	14		80	24.4	129	39.3	
Warren	6	and variations	30	9.1	87	26.5	
Double multiple	4	and variations	63	19.2	111	33.8	
Double town	4		98	29.9	122	37.2	
Double warren	1		116	35.4		0.0	
Other / unknown	23						
	880						

*From the *World Guide to Covered Bridges*, published by the National Society for the Preservation of Covered Bridges, Inc., 1989 edition.

Reasons for Using Covered Bridges vs. Other Alternatives

As stated earlier, the reason these timber structures were covered was simply to help protect the timber from the ravages associated with periodic wetting. Those involved with early truss structures have stated that timber truss structures without coverings would often fail after 10-20 years of service. Coverings quickly proved their worth by greatly extending the life of the structure—so much so that the use of timber structures without coverings was only for a brief period of time.

The development of the timber truss allowed these bridges to span greater distances than those with beam-only structures. They were also able to surpass the spanning capability of arch structures, whether of stone, masonry, or timber.

The development of processes that produced wrought iron and cast iron in larger capacities during the mid-1800s soon led to truss types made of progressively more metal. Timber trusses quickly lost their popularity in the late-1800s and were used less and less after the early 1900s, except in those areas of plentiful large timber.

Chapter 3. Historical Development of Covered Bridges

A brief perspective of the historical development of covered bridges is provided in this chapter. Additional, in-depth information is available in many of the references. Perhaps the best in-depth discussion of this topic is that authored by J. G. James. In 1982, he prepared a compendium entitled, "The Evolution of Wooden Bridge Trusses to 1850."^[5] His acknowledgements and apologies humbly explain that he prepared the material as an offshoot to his real love of iron trusses, for which he had prepared an earlier paper. The material was reprinted more recently in the United States, in 1997 and 1998 issues of *Covered Bridge Topics*.^[6] Other sources provide even more distilled and generic summaries of the evolution of truss development, although it is very difficult to accurately portray such rapidly changing, complex events.

Figure 20 shows one of the rare double-barrel covered bridges and one of the older in the United States (although the date of original construction is controversial.) The sidewalk on the left is a more recent addition.



Figure 20. Rare, old double-barrel covered bridge—Pulp Mill Bridge, Middlebury, VT.

The following historical context is intended to describe some of the challenges surmounted by those engineers and contractors who have built bridges that spanned distances longer than the longest available timbers.

The Development of Truss Concepts in Europe

Andrea Palladio, a Venetian architect (1518-1580), is usually credited as the first to describe the form of structure we recognize as a truss, as presented in his *Four Books of Architecture*, more commonly referred to as his *Treatise on Architecture*, or simply *Treatise*, circa 1570. Yet some say that he was really only the first to publish information known to many at that time, including examples constructed (and possibly still extant) in Switzerland. In either event, little attention was paid to his writings until the middle of the 18th century, when European nations began building the bridges required for significant transportation systems. Although France had been the leader in early engineering, based primarily on their advances in stone and arch theory and construction, the Swiss and Germans were devoting more attention to using timber trusses in their bridges. Most timber bridges in Europe were not covered, although the oft-cited Schaffhausen Bridge over the Rhine River, constructed by the Grubenmann brothers in 1758, which included an awkward and inefficient timber roof, was an impressive two-span (52.1-m (171-ft) and 58.8-m (193-ft)) bridge. Many of the other early examples of covered bridges stemmed from efforts to provide roofed galleries, usually over simple pile and beam bridges, dating back many centuries.

These early timber covered bridges were somewhat primitive; they consisted of piles driven into the riverbed, with timber beams spanning longitudinally between pile caps. The covers were more for the convenience of users who wanted to linger on the pleasant bridge setting. To span deeper rivers or gorges, the 18th century builders found piers to be costly, if not impractical, and they began looking for ways to span greater distances. They did not move directly to pure truss forms; they first used some versions of braced beams. Early German and Swiss truss bridges relied on kingpost and queenpost configurations with modifications to add arch action, via a strutted beam. Some of the German bridges included diagonal panel bracing in trusses with parallel top and bottom chords. The Swiss often relied more on ever-heavier timber framing, without many diagonal members. They preferred to build very deep beams, using mechanical connectors between stacked layers—an effort at laminating deep members from smaller members without relying on structural adhesives. Other developments in the evolution of timber truss bridges followed in several other European countries, but early bridge building in the United States really led to the most significant advancements in the theory of truss behavior.

Early Truss Construction in the United States

Americans who wanted to travel inland from coastal areas immediately faced the need to span streams of various sizes. Those sites conducive to pile driving were crossed with the classic multiple-span, timber stringer structures. Deeper water demanded longer spans. The gradual developments in Europe provided insufficient guidance to the American pioneers faced with a compelling need to build so many and such demanding structures as fast as they were needed. As might be expected, enterprising and ingenious American craftsmen, business people, and visionaries forged ahead, willing to test a myriad of structure styles to meet the demand for safe waterway crossings. Some of these structures were modeled after examples in Europe, while others clearly included ideas unique to the Americans.

A notable advancement in timber bridge building was the crossing of the Connecticut River at Bellows Falls, VT. Colonel Enoch Hale used a two-span structure with total length of 111 m (365 ft). The supporting structure was a strutted beam; it took advantage of a natural and striking rock pier in the middle of a natural cascade. The bridge was immediately considered a major accomplishment, because it was the first to provide spans longer than possible with simple beams.

Hale's bridge was not an isolated case. Many old bridges took advantage of natural features. Figure 21 shows a stone abutment that should last long after the bridge.

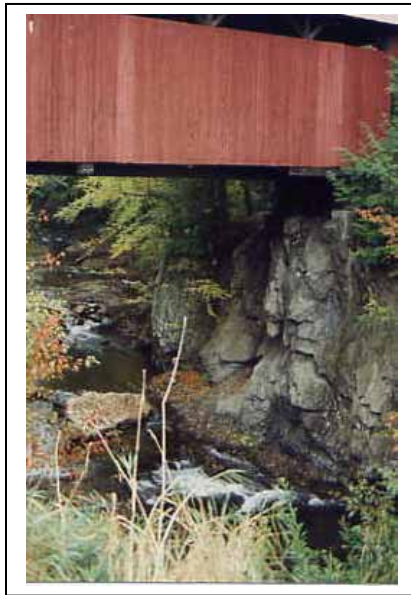

Figure 21. Classic use of a natural formation as an abutment—Red Bridge, Morrystown, VT.

The First Covered Bridge in the United States

Another American bridge pioneer was Timothy Palmer. He was an extraordinarily energetic, talented, and prolific bridge builder who experimented with progressively flatter structures that relied less on arch action. The bridges built by Palmer through his career consistently used more panel braced timber frames in configurations that can be identified as trusses. After constructing several large bridges, Palmer sought and gained approval to span the Schuylkill River at Philadelphia, PA. His resulting structure was substantially different from earlier bridges built at the same spot, and included three spans (two of 45.8 m (150 ft)), and one of (59.4 m (195 ft)) without struts from below. The trusses were built of heavy timber members with bracing, and the bridge was completed in 1805 or 1806, depending on the source. The bridge was expensive and critical to ongoing commerce, so it was enclosed with sides and a roof to protect it from weathering, leading to its name the Permanent Bridge. Although there are hints of even earlier covered bridges in the United States, this bridge is most often cited as the first.

Patents and Covered Bridges

The United States established its first patent office in 1790. Tragically, for the purposes of historical research, a fire destroyed this office in 1836 with the loss of all patent records to that date. Efforts were made to restore as many of the patents as possible, yet many remain lost forever. Hence, any definitive statements of fact regarding the earliest patents related to the developments of timber trusses and covered bridges are suspect. Not surprisingly, some historians have made heroic efforts to compile as many of the lost pieces as possible. Richard Sanders Allen deserves special recognition for his compendium of "Thirty-Two Lost Bridge Patents." As his title suggests, even just the recovered patent variations alone are too numerous to fully describe in this manual. In an ongoing effort to focus on the surviving authentic examples of North American covered bridges, the following discussion includes only the more prominent developments.

Early North American bridge builders actively pursued patents for their designs in an attempt to gain more bridge construction contracts. A few of the very first patents involved general bridge construction, but by 1797, there were several that involved specific schemes for timber arches. Among others, Timothy Palmer received a patent that year, the details of which remain unknown, but he began construction of his Permanent Bridge only a few years after this, his initial patent.

Theodore Burr obtained the first of his many patents in 1804 or 1806, (again, according to the source), which regrettably remains among the unrecovered records. His second patent was issued in 1817. Burr's trademark design dates from this patent. He extended curved lower ribs that had reached only bottom chords, up along the trusses, all the way to the top chord. This superposition of arch and truss forms seems to have been influenced by earlier bridges built in Switzerland. The resulting structure has been described as a combination of conventional trusses (parallel chords with compression diagonals) and supplemental arches. One of Burr's early examples of this bridge form, and probably the basis for his 1817 patent, was his Union Bridge crossing of the Hudson River between Lansingburgh and Waterford, NY, circa 1804. This was a significant structure; 244 m (800 ft) long, with four spans. The structure was rebuilt after being in service for some time, to include a roof and siding. This heavily braced and counterbraced structure exemplified what today is called a Burr arch.

Lewis Wernwag was born in Germany in 1769 and obtained a patent (which is also lost) in 1812. The patent most likely described a structure similar to his crossing of the Schuylkill River at Philadelphia, PA's Upper Ferry. The huge 104-m (340-ft) trussed arch span was quickly termed the "Colossus" and represented a major triumph in bridge construction, with its attractive and apparently efficient use of timber, supplemented with iron rod bracing members. Wernwag owned a metal works company and relied more on early forms of metal connections and components rather than on traditional timber joinery only. He received a second patent in 1829 for improvements in his structure. Regrettably, the bridge was lost to fire in 1838.

Ithiel Town (1784–1844) of New Haven, CT, was a prominent architect known for designing many types of buildings. He also planned many bridges, initially experimenting with various truss arch combinations. However, Town wanted to devise a structure that would require fewer carpentry skills than was required by the intricate joinery details of some of the early bridges. Using only planks joined with round wooden pegs, he began developing a lattice style of truss construction and obtained his first patent in 1820. He was nearly as good a promoter as an inventor, and the lattice truss became very popular, although it has been criticized for its apparent waste of material. This truss layout proved to be very adaptable. It could include heavier members for longer spans, and could even be doubled up to include two layers of web members and three layers of chords for heavy loads, such as those generated by the railroads. A few of his bridges were built with such heavy members that they became identified as a timber lattice, as compared with the more common plank lattice. The most famous of the surviving timber lattices is found in the Windsor, VT-Cornish, NH, covered bridge over the Connecticut River, which remains one of the longest two-span covered bridges in the United States.

Stephen Long (1784–1864) had a varied background and career. He gained his experience as a timber bridge builder while serving in the U.S. Army. Long was commissioned to locate, plan, and build the Baltimore and Ohio Railroad. He chose to use a standardized truss for all his spans, with timber counterbraces in all the panels. With the addition of timber wedges at the bearing joints between the posts and diagonals, he found that he had better control over the trusses' as-built geometry. He obtained his first bridge patent in 1830. Subsequent printed materials pronounced that these wedges allowed the truss builders to induce member forces in the trusses that effectively prestressed the structure, to employ today's terminology.

William Howe (1803–1852) made a major contribution to the evolution of timber covered bridges by being the first to use metal components as primary members within an otherwise timber truss. He used parallel timber chords, with timber diagonals and counters in the panels, but he used round iron rods for the vertical tension members. The threaded rod ends allowed easy adjustment of the structure, to keep it tight both during and after erection. Many modifications were made over the years to Howe's original design to address various desired details, but his truss was quickly adopted to withstand the heavy loads on railroads. The popularity of the Howe truss continues today. It is often selected when constructing new covered bridges. Howe's modification was a major reason for the short life and reduced popularity of Stephen Long's truss—which was essentially the same, but without the iron rod verticals.

Prevalence, Prominence, Demise, and Resurgence

There are many reasonable estimates of the number of covered bridges that have been built in the United States. One very conservative and informed estimate is that at least 10,000 covered timber bridges were built before 1900. Figure 22 shows what appears to be an authentic date carved in the end post of a bridge in Vermont. An examination of the data from the *World Guide* indicates that the largest number of extant covered bridges was built during the 1870s. Subsequent decades saw progressively fewer bridges built. The 1930s seem to end the major construction of covered bridges. Very few were built in the following decades until renewed interest in them developed in the 1960s. This revival of the builders' craft was due, in no small part, to Milton Graton. His 1978 book, *Last of the Covered Bridge Builders*, is a fascinating collection of stories and information from his many years spent rehabilitating existing covered bridges and constructing new examples.

There are many examples of authentic, but new, covered bridges built in the last few decades of the 20th century. Interestingly, of the 30 States that currently have covered bridges, more than half have built a new covered bridge within the past 30 years; some have built several. Although some owners, engineers, contractors, and even bridge users have distinct preferences for specific truss types, these newer bridges have used nine different truss types.



Figure 22. Date carved in an end post of the Westford Bridge, Westford, VT—may be original to the bridge.

SECTION 2. DESCRIPTION OF BRIDGE COMPONENTS

- Chapter 4 Types of Longitudinal Trusses
- Chapter 5 Floor Systems
- Chapter 6 Ancillary Features
- Chapter 7 Foundations

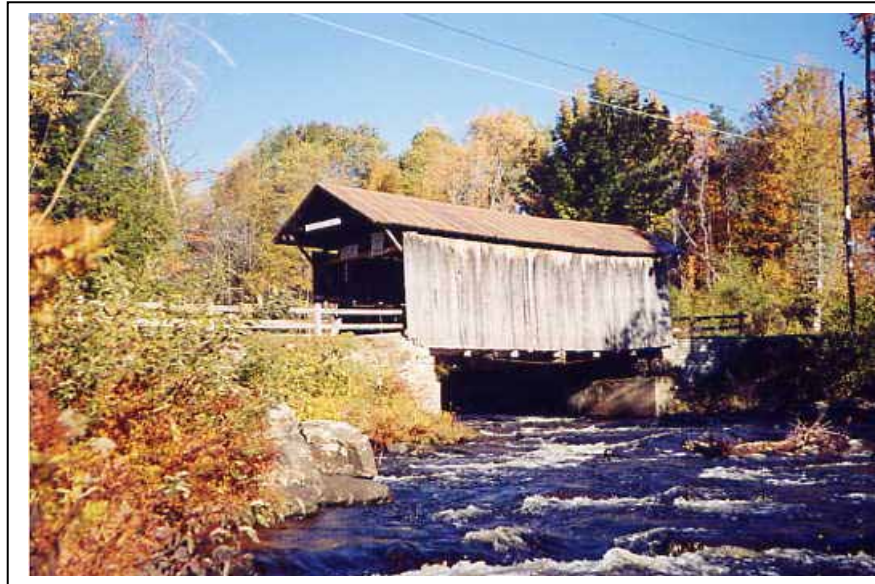

Figure 23. Salisbury Center Bridge—Herkimer County, NY.



Figure 24. Brown Bridge—Shrewsbury, VT.

Chapter 4. Types of Longitudinal Trusses

This chapter describes the key engineering features of the timber truss types introduced in chapter 3. Terminology and illustrations are included to facilitate comparisons and contrasts among the truss types. Special details are highlighted.

The truss types described here are presented in the order of their span length, starting with the shortest. The first three truss types (kingpost, queenpost, and multiple kingpost) are ones used in the earliest North American covered bridges. No patents were ever taken on their configurations, and no individual is specifically credited with their development. The other truss types that follow were developed and ultimately named after enterprising early builders/engineers (usually in recognition of a patent obtained for the details of the truss).

Kingpost

The most elementary heavy timber truss configuration is the kingpost (see figure 25). The inclined members of a kingpost truss serve both as the top chord and as the main diagonals, and resist compression forces. The horizontal member, along the bottom of the truss, is the bottom chord and acts in tension. A central vertical member (the kingpost), also acts in tension to support the floor loads and serves as the connecting element between the opposing main diagonals. The kingpost truss configuration has two panels. A panel is that portion of the truss that lies between any two vertical components.

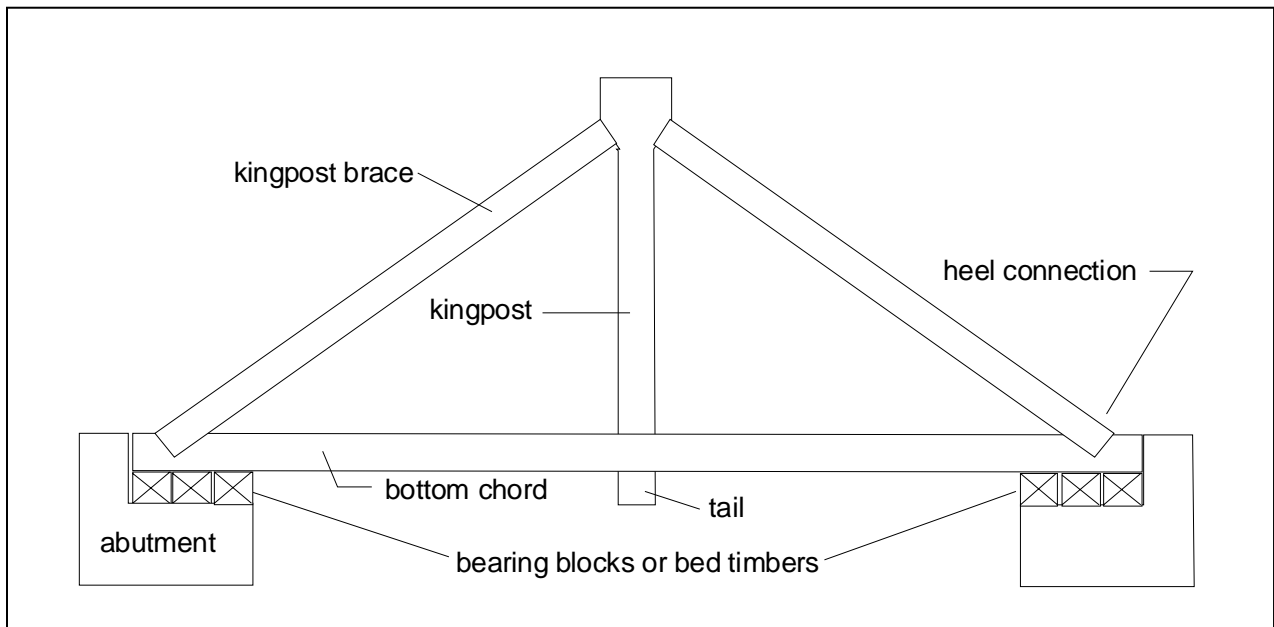

Figure 25. Diagram of kingpost truss.

In addition to resisting the tensile forces generated by the opposing diagonals, the bottom chord almost always supports the floor beams. In most kingpost truss bridges, the floor beams are located only at the ends of the bridge and next to the center kingpost. The floor beam point loading does not coincide with the intersections of the theoretical centerlines of the truss members. This connection eccentricity induces bending stresses in the bottom chord that may be large or negligible, depending on the distance of the floor beams from the joints and the depth of the bottom chord.

The dead and live loads are applied differently to kingpost trusses. Live traffic loads are carried to the truss through the central floor beam, while much of the bridge dead load is carried in the rafter plate,

along the eaves of the roof. As a result, almost half of the bridge weight is carried to the end posts of the bridge, which transfer their loads directly to the foundation. The kingpost truss carries the centerline floor beam(s) and the inner ends of the four eave plates. Technically, the end posts and the eave struts are not structural members of the kingpost trusses, and their connections are not intended to transfer axial loads within the truss; they are simply members of the associated framework.

The inclination angle for the kingpost diagonals is restricted. Generally, steeper diagonals are more efficient at resisting shear forces in a truss. There are, however, compromises to consider when laying out the members in any truss. For instance, given a set span for a two-panel kingpost truss, steeper diagonals make taller trusses. Beyond the aesthetic issues of building unusually tall, but short-span structures, there are practical limits to the height of the bridge involving bracing and its connections. Hence, the span limit for this simplest truss is quite short, typically only about 7.6 to 9.1 m (25 to 30 ft).

Longer kingpost trusses have been built by including subdiagonals. These members act as braces, from the bottom of the kingpost up to the midpoint of the main diagonals, thereby producing a minitruss within the larger kingpost truss. Short struts often extend above this junction to support the load from the roof eave plate. Vertical metal rod hangers may also be used from the intersection of these subdiagonals downward to the bottom chord, allowing installation of floor beams at this quarter point of the bridge. These modifications allowed builders to increase kingpost spans out to about 10.7 to 12.2 m (35 to 40 ft).

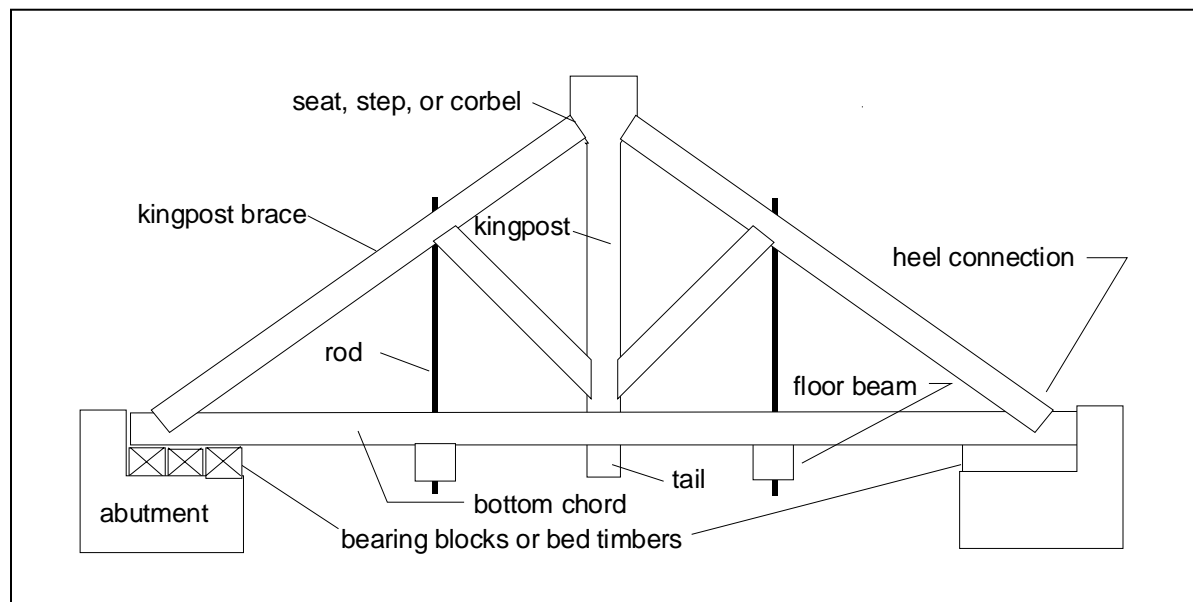

Figure 26. Diagram of kingpost truss with subdiagonals.

Most kingpost trusses were built with single member components, usually large sawn or hand-hewn timbers. The most critical connection in kingpost trusses is the heel connection of the main diagonals to the bottom chord. These connections are prone to several weaknesses discussed in more detail later.

The kingpost truss is not very common in the extant United States covered bridge population. There are only about 30 kingpost covered bridges¹ remaining in the United States, with spans ranging from 6.7 to 21.3 m (22 to 70 ft).^[1] It is very unusual for a kingpost bridge to span 6.7 m (70 ft)—approximately 15.2 m (50 ft) would be the more common upper limit. The extant kingpost bridges were built between 1870 and 1976.^[1]

Queenpost

The next range in span lengths commonly includes trusses developed from a simple modification of the kingpost. The queenpost truss is, conceptually, simply a stretched-out version of the kingpost truss,

accomplished by adding a central panel with extra horizontal top and bottom chords (see figure 27). Classic examples of queenpost trusses do not have any diagonal web members in the central rectangular web panel. Therefore, the most simple queenpost trusses are not true trusses at all,; but rather frames (although this distinction is not relevant to this discussion). The vertical members are termed queenposts. These trusses are considered to have three panels.

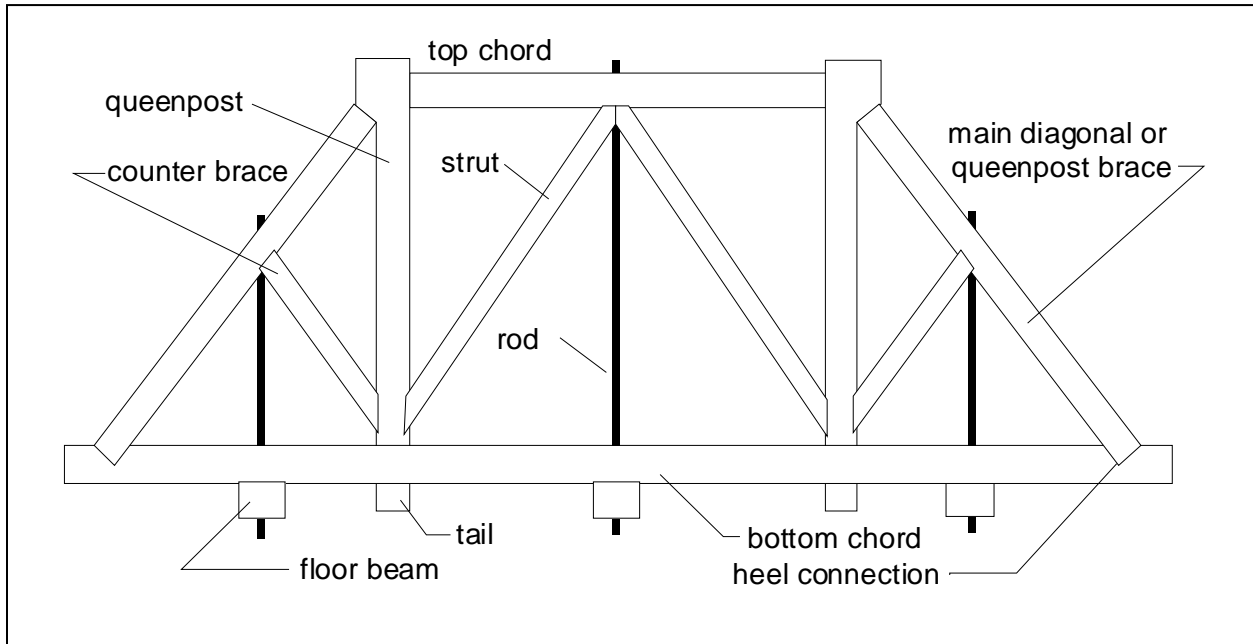

Figure 27. Diagram of queenpost truss.

The member forces and behavior in queenpost trusses are very similar to those found in kingpost trusses: therefore, the design considerations for these two basic truss styles are equally similar. A number of similarities exist between kingpost and queenpost trusses:

Truss components are usually of single members.

The key area of interest is the heel connection.

Some of the longer spans use subdivided panels, with subdiagonals, hanger rods, and extra floor beams.

The span lengths of queenpost truss bridges range from about 12.2 to 18.3 m (40 to 60 ft), although there are a few examples that are longer. The longer span requires that many of their bottom chords be spliced longitudinally from separate timbers. This tensile connection is another area of weakness in the truss and is discussed in more depth later.

There are approximately 101 bridges supported by queenpost trusses, or slightly more than 10 percent of all the surviving covered bridges in the United States. Their spans range from 7.6 to 39.6 m (25 to 130 ft), and they were built between 1845 and 1985.^[1]

Multiple Kingpost

A straightforward way to stretch the span capability of the queenpost truss is to add panels to the kingpost truss to create what is known as multiple kingpost trusses (see figure 28). Accordingly, the basic kingpost truss is sometimes referred to as a simple kingpost truss. (The image depicted in figure 28 demonstrates verticals that have been cut down to accept the diagonal; –some refer to these as gunstock verticals. The verticals depicted in figure 29 are, perhaps, more commonly notched to accept the diagonal.) Most of these trusses were built with an even number of panels so that all the diagonals are in compression and all the verticals are in tension under normal loading. Very few multiple kingpost trusses have an odd number of panels, with opposing (or crossing) diagonals in the center panel.

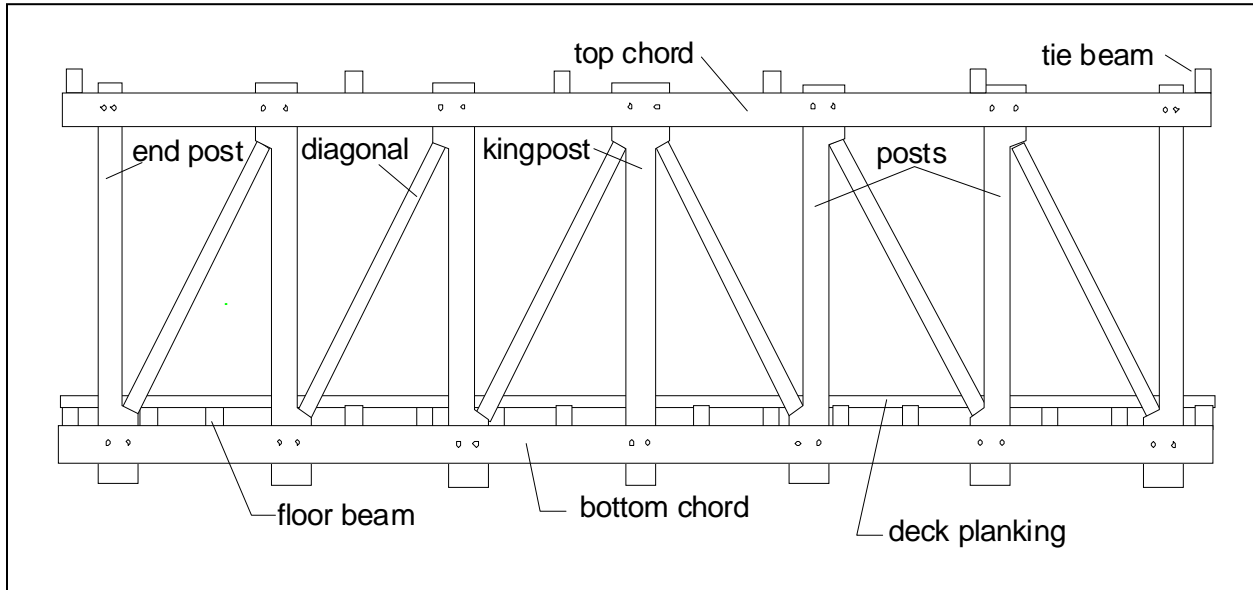

Figure 28. Diagram of multiple kingpost trusses.

There is a lack of tensile capacity of the connection of the diagonals to posts. In this instance, the compressive force in the diagonals under the influence of the dead load of the bridge is usually much larger than the tensile force resulting from the passage of vehicles. Hence, under normal circumstances, the diagonals remain in compression under all combinations of loading, and the tensile connection is unnecessary.

The longer spans of the multiple kingpost truss, without increasing truss depth significantly, generate higher member forces, which require more capacity. Multiple kingpost truss chords are often comprised of twin members that sandwich a central plane of single web (vertical and diagonal) members. The longer chord members also usually require splices that typically are staggered along the truss length. This critical detail is meant to ensure that, at any particular cross section along the bridge, there is at least one unspliced bottom chord (tension) member in each longitudinal truss; —more specifically, there should be 1 m (3.28 ft) separation between splices of adjacent members of the bottom chord.

The panels in multiple kingpost trusses are often quite short, which means that the transverse floor beams could be located abutting each vertical member. This minimal eccentricity between load application and truss joint location greatly reduces bending stresses in the bottom chord. In addition, these more closely spaced web members tend to have smaller member forces in the diagonals due to their geometry, so that the connection forces are somewhat smaller than those associated with kingpost or queenpost trusses.

The truss diagonals bear on shoulders cut into the sides of the vertical tension members. This means that the verticals must be made from substantially wide timbers. Unfortunately, this joint eccentricity means that the shoulders of the verticals are significantly overstressed in shear along the grain. Many truss verticals have failed in shear; it is common to find evidence of separation and slippage of the shoulder relative to the main portion of the vertical. This can happen at either the top or bottom of the post. Figure 29 provides an example of a shear failure at the notch for the diagonal. Note the vertical shift of the right half of the post above the notch, most noticeable at the top of the post. This is from the Mill Bridge in Tunbridge, VT, before it collapsed due to flooding-borne ice impact in 1999.

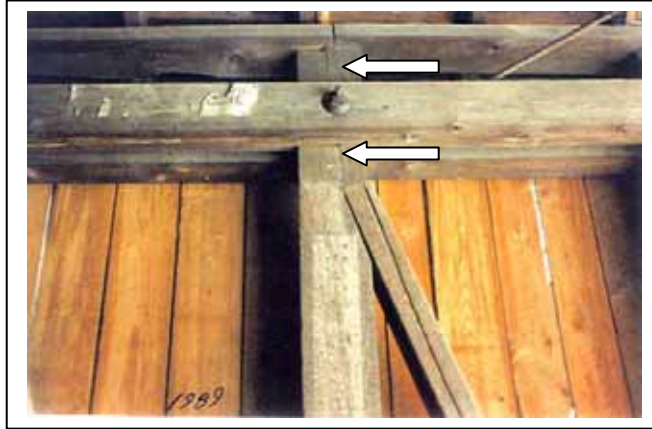

Figure 29. Shear failure of a vertical at a notch—Mill Bridge, Tunbridge, VT.

Another truss component that suffers a common weakness is the bottom tail of the vertical member. It is subject to the same high shear stresses as discussed and illustrated above. The tails are also subject to impact by floodwaters, debris, and/or ice floes. In many instances, the tails have been broken off, as illustrated below. Unfortunately, the tails hold the chords in place vertically, and collapse of the floor is probable when the tails are broken. Figure 30 presents an example of a complete fracture of a tail from ice impact, which was subsequently repaired. Figure 31 provides a view along the same bottom chord showing the bowing due to the impact to the inside of the bottom chord from ice floes, from right to left. The broken tail is just outside of the photo. Looking closely, one can see that the chord has been pushed out from under the floor beams at midspan. Only the longitudinal timber decking, spiked to the floor beams, kept the floor from falling into the river.



Figure 30. Example of a broken tail from ice impact—South Randolph Bridge, VT.

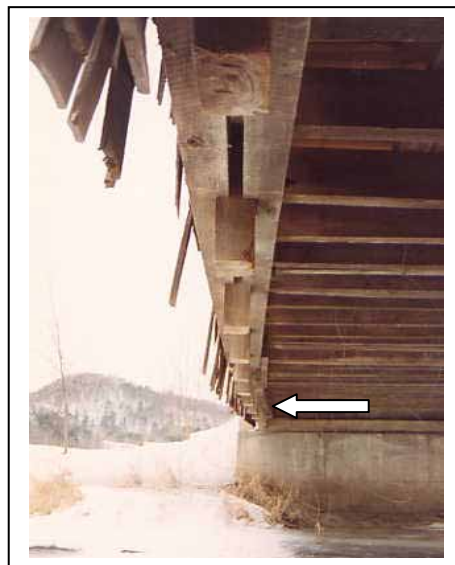

Figure 31. Bowing of bottom chord due to impact from ice floes—South Randolph Bridge, VT.

About 95 bridges using multiple kingpost trusses remain, or a little more than 10 percent of all covered bridges in the United States. Multiple kingpost trusses have spans that range from 11.0 to 41.1 m (36 to 124 ft), and they all seem to have been built between 1849 and 1983.^[1] Interestingly, comparing the span ranges and the construction dates between queenpost and multiple kingpost trusses, one may observe the similarity of these two features.

Burr Arch

As noted in chapter 3, Theodore Burr obtained the first U.S. patent issued for a specific timber truss configuration in 1806. The Burr arch is, basically, a combination of a typical multiple kingpost truss with a superimposed arch (see figure 32). The arch was added to allow heavier loads on the bridges and to stretch their span capabilities to greater lengths. Surviving examples of Burr arch bridges have spans of up to 67.7 m (222 ft).^[1]

Burr's development was immediately popular with bridge builders and has proven durable. More existing North American covered bridges use the Burr arch than any other type. The classic, or conventional, Burr

arch supports the ends of the arch components at the abutment, with no connection between the bottom chord and arch as they pass each other (the chord is supported by the abutment directly separated from the arch end). A variation of the Burr arch (sometimes referred to as a modified Burr arch) terminates (and ties) the arch with a connection directly to the bottom chord, which is supported on the abutments.

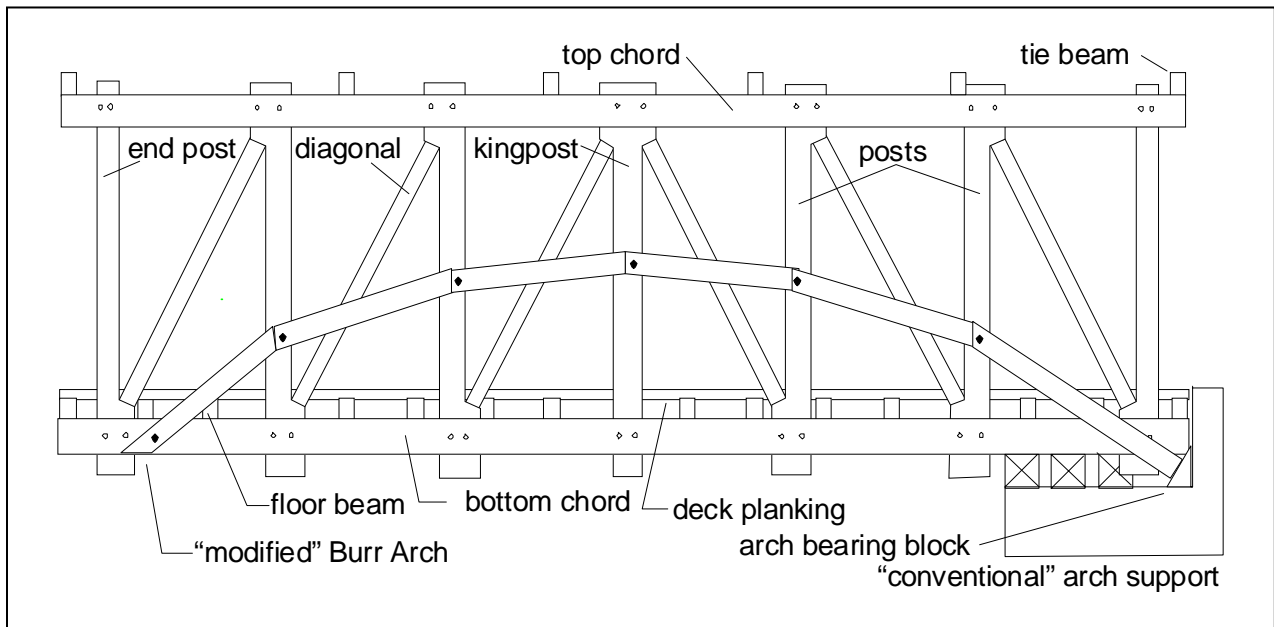

Figure 32. Diagram of conventional and modified Burr arch.

The actual arches of most Burr arches are in pairs; these sandwich a single multiple kingpost truss between them. The most common connection uses a single bolt to join the arches through each of the vertical members of the truss. This means that the load sharing between the truss and the arch components is largely dependent on the relative stiffnesses of those bolts. The floor beams carry the live loads to the truss bottom chords, and the roof loads bear on their top chords. For these vertical loads to be distributed into the arch, the bolts must resist significant vertical shear forces. The initial, traditional Burr arches used arch components sawn from large, single timbers that were lap-spliced to each other at the verticals. Later, use of continuous but laminated (multiple-layer) timber arches became popular with some builders.

In addition to the critical areas of interest cited above for the multiple kingpost truss that comprises the central portion of the Burr arch structure, special attention should be paid to the ends of the arches and the interconnections of the arch to the truss. Figure 33 shows the connection of timber arch with post using only a single bolt. This Burr arch happens to have a dual timber arch, —one above the other.

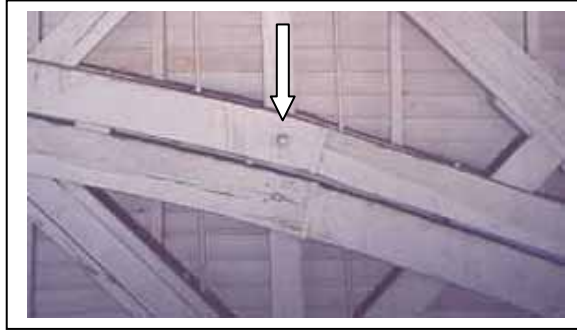

Figure 33. Connection of arch to post—Wehr Bridge, Lehigh County, PA

There are about 224 remaining bridges supported by the Burr arches and its multiple variations (about 25 percent of all covered bridges).^[1] The Burr arch has individual spans that range from 10.0 to 67.7 m (33 to 222 ft); this longest span is 10 percent longer than the next rival configuration of truss (the Howe). The extant Burr arches were built between the early 1800s and 1988.^[1]

Town Lattice

Ithiel Town, an architect by education, obtained his first patent for a unique type of timber truss in 1820 (see figure 34). All the other trusses mentioned above, and those that follow this subsection, principally rely on large and heavy timbers that require skilled artisans to properly craft the rather elaborate joinery between the various components. Town sought a means of constructing bridges that would rely on an easily adapted design and would require less skilled labor. His patented truss developed a configuration that could be extended to a wide range of span lengths with relatively little modification of the configuration. In the opinion of many informed bridge aficionados, his patented truss represents arguably the most important development in the history of covered bridges, and one that remains a popular and enduring style. Later portions of this manual will examine the merits of this truss configuration.

Town's lattice configuration relies on assembling relatively short and light planks that were available and easy to handle. He connected the overlapping intersection of members with round timber dowels or pegs, termed treenails—pronounced trunnels (and so spelled hereafter in this manual). The plank intersections in the web may have from one to three trunnels. Where chord members intersect with web or lattice members, the overlapping zone may contain as many as four trunnels. The dowels are often 38 to 51 millimeters (mm) (1.5 to 2 inches) in diameter. The parallel and closely spaced web members are joined to chords along both the top and bottom of the trusses. Two levels of chords commonly are used as the bottom chords. The top chords may have one or two levels of members. The lowest bottom chord provides the seat for the transverse floor beams.

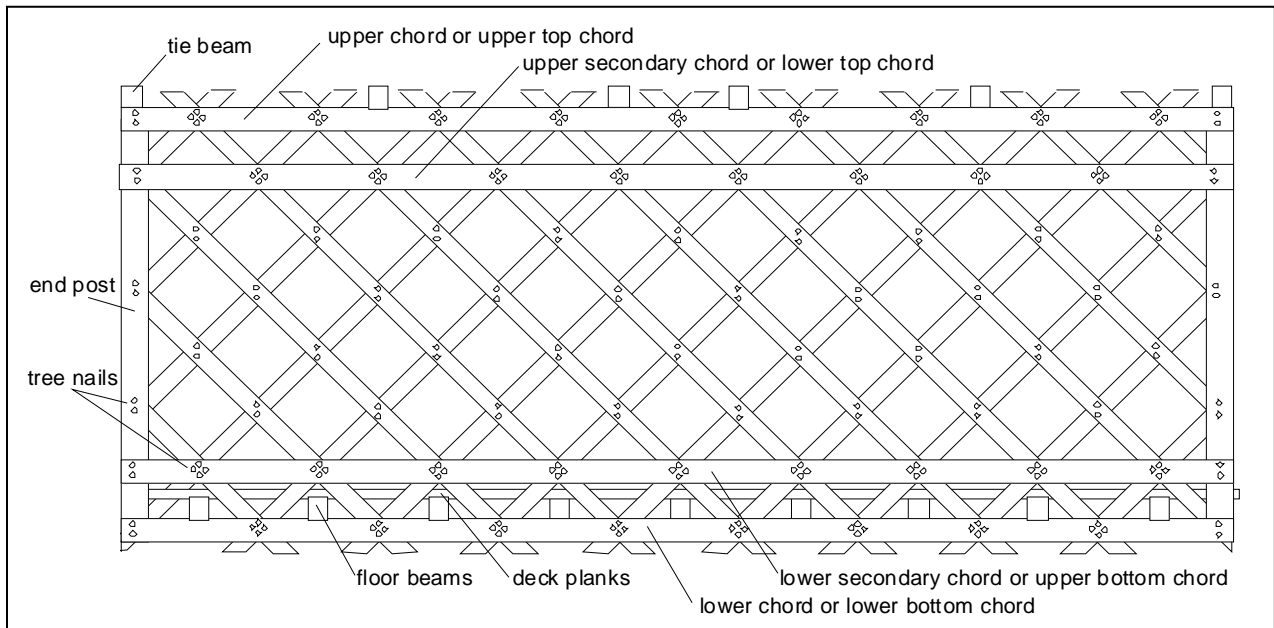

Figure 34. Diagram of Town lattice truss.

Town, or lattice, trusses are most commonly comprised of thin members with pairs of chords on each side of the lattice webs. In this case, the truss is sometimes termed a plank lattice. The chord members generally are not spliced to abutting pieces at their ends, but the terminations are staggered so that any panel of chord has at least one unspliced member. A few Town lattice trusses were fabricated of heavier components using single chord members on each side of the lattice. In this case, the truss is termed a timber lattice. The chord members require splices at their ends.

There remain about 135 bridges supported by Town lattice trusses.^[1] Town lattice trusses support varying span lengths, from relatively short (only 7.6 m (25 ft)), up to some of the longest covered bridge spans in the world. Individual Town lattice trusses span up to 49.4 m (162 ft).^[1] The oldest surviving Town lattice bridge (the Halpin Bridge in Middlebury, VT) was purportedly built about 1824.^[1] New examples of Town lattice covered bridges are still being built.

Long Truss

Colonel Stephen H. Long first patented a truss configuration in 1830. His focus was on a parallel chord truss made with heavy timbers and with crossed diagonals in each panel (see figure 35). A special feature of his bridge included the use of timber wedges at the intersections of the chords, posts, and diagonals. The wedges allowed builders and maintainers to adjust the shape of the panels, and provided the opportunity to adjust the initial camber.

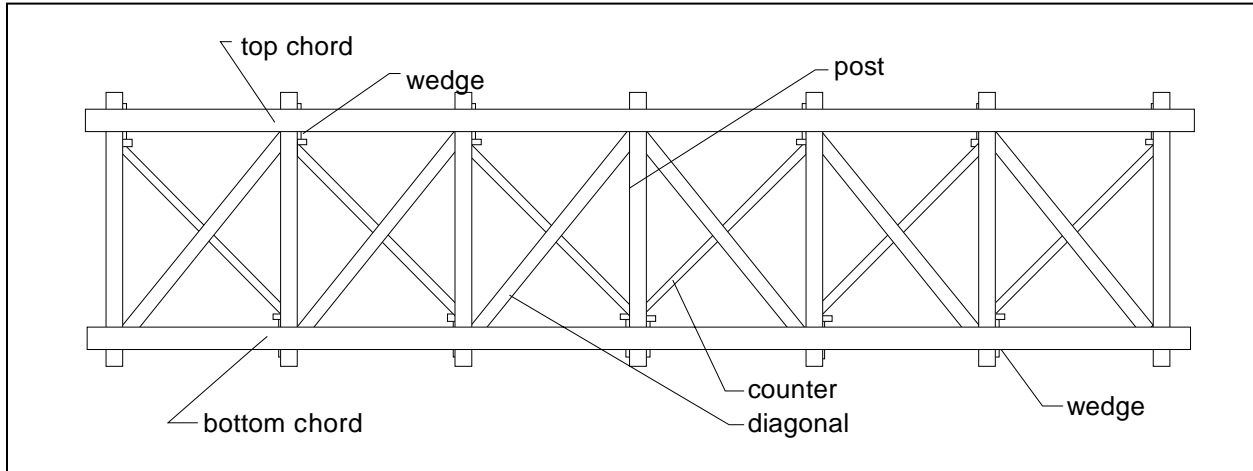

Figure 35. Diagram of Long truss.

In today's jargon, the wedges allowed builders to induce forced loads in the diagonals in a way that is described as prestressing. It is extremely difficult to predict the amount of the induced prestressing force. Long's patent applications included images of wedges between the vertical and the chord (as shown in figure 36) and between the counter and the chords (as indicated in figure 35).

However, the wedges do increase the strength of the connection between the horizontal component of the load in the diagonal and the chord. The transfer of load without wedges flows from the end bearing on the diagonal to the cross grain bearing in the post, then from the cross grain bearing at the shoulder of the post back to the end grain bearing at the shoulder of the chord. Introducing the wedge distributes the bearing load from the chord over a much larger area of the post through the wedge in direct cross grain bearing.

Figures 36 and 37 clarify how Long wedges work. The image in figure 36 is from the outside of the bridge (siding and outside chord stick removed) looking back toward the inside of the bridge. The wedge on the right side normally is hidden from view by the floor beam. As the wedge is driven downward, the post is moved with respect to the chord along the shoulders cut in the chord stick. An important engineering aspect of the wedge is to distribute large edge stresses along the vertical face of the shoulder across a wider face of the post at the interface with the wedge.

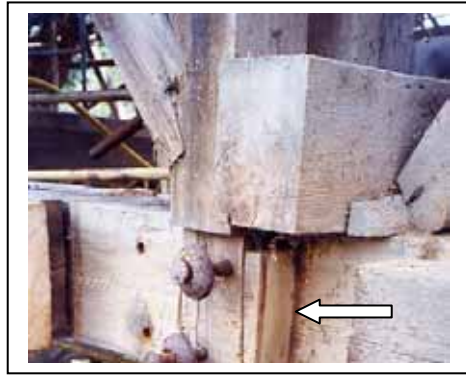

Figure 36. Long truss bottom chord wedge—Downsville Bridge, Delaware County, NY.

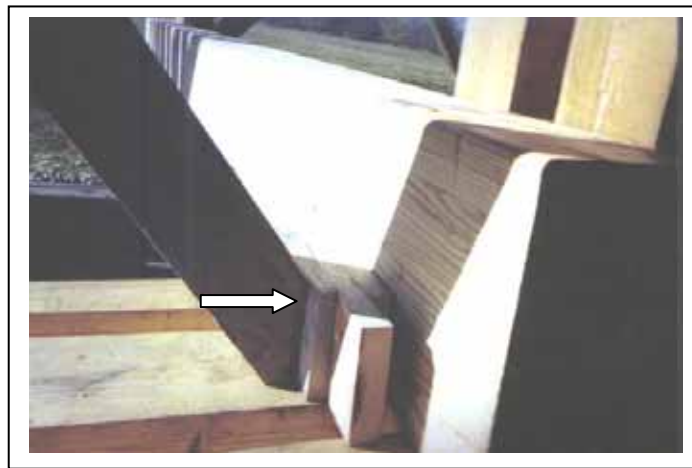

Figure 37. Wedges between counter and floor beam in a Long truss—Hamden Bridge, Delaware County, NY.

The Long truss was adopted by many builders for use in highway and railway bridges, but the timing of its introduction meant that it was destined to be overtaken quickly in popularity by the Howe truss, as discussed in the following section.

There are about 40 surviving bridges supported by the Long truss, with individual spans that range from 15.5 to 51.8 m (51 to 170 ft).^[1] The oldest extant Long truss was built in 1840, and the newest was built in 1987.^[1]

Howe Truss

William Howe (1803–52) of Massachusetts was granted his first truss patent in 1840 and a second one later in the same year. His second patent used metal rods as the vertical members of what was otherwise a simple timber parallel-chord, cross-braced truss. This was the first truss patent granted with some major structural components made with metal. The configuration used easy-to-erect and readily prefabricated components that could be assembled on site and adjusted via threaded connections at the rod ends. Little skilled labor was involved in assembling and erecting this truss type, and it became an immediate success (see [figure 38](#)).

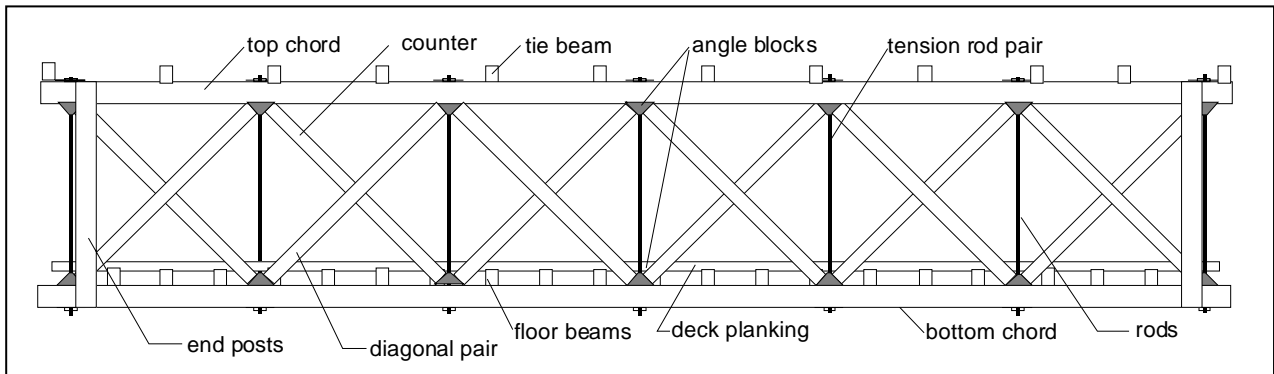

Figure 38. Diagram of Howe truss.

Another factor in the success of Howe's truss type was his inclusion of a detailed structural analysis with the patent application. Up to this time, the selection of member sizes, materials, and overall geometry, was generally left to the judgment of the individual bridge builder. The fledgling structural engineering profession was developing rules and relationships to govern such matters, but no consensus had been attained at the time of Howe's patent.

The initial Howe truss bridges had wooden blocks cut to fit at the connections at the ends of the diagonal members against the chords. Later versions converted to the use of cast iron angle blocks. These blocks were simple to construct and install, and they were a major factor in the popularity of this configuration.

The Howe truss is second only to the Burr arch in popularity of extant covered bridges in the United States. There are about 143 bridges supported by the Howe truss, or about 15 percent of all covered bridges.^[1] The Howe truss has individual spans that range from an unusually short 6.1 m (20 ft) up to an impressive 61.0 m (200 ft), the longest being only 10 percent shorter than the longest Burr arch.^[1] The oldest extant Howe truss was built in 1854, and the configuration remains popular with new authentic examples built today.^[1]

Other

The preceding seven truss configurations support the vast majority of covered bridges. There are many other truss configurations, however, that were patented with a few representative examples still standing, including those identified as Smith, Paddleford, Pratt, Childs, and Partridge trusses. Each of these trusses contains some technical nuance to differentiate it from others, but the basics of their behavior follows those described above.

The Pratt truss deserves special note because it was the precursor of the very popular metal truss of this configuration. In the initial form, Pratt used metal rods for the diagonal tensile elements and timber in the compression posts, taking advantage of the respective strengths of those materials. Very few Pratt timber truss bridges remain, in large part due to the difficult connection of the diagonals to posts, but a very large number of Pratt metal trusses survive, in which the connections with metal were simplified.

While very few exist, the Paddleford trusses (see figure 39) are remarkable in that the assembly of interconnected timbers requires exceptional skill for a proper fit. These structures behave more like frames than trusses, involving shoulder bearing at the frame connections with much of the resistance due to shear and bending stresses in the elements, in addition to the axial forces. The analysis of these structures is especially complex and challenging.

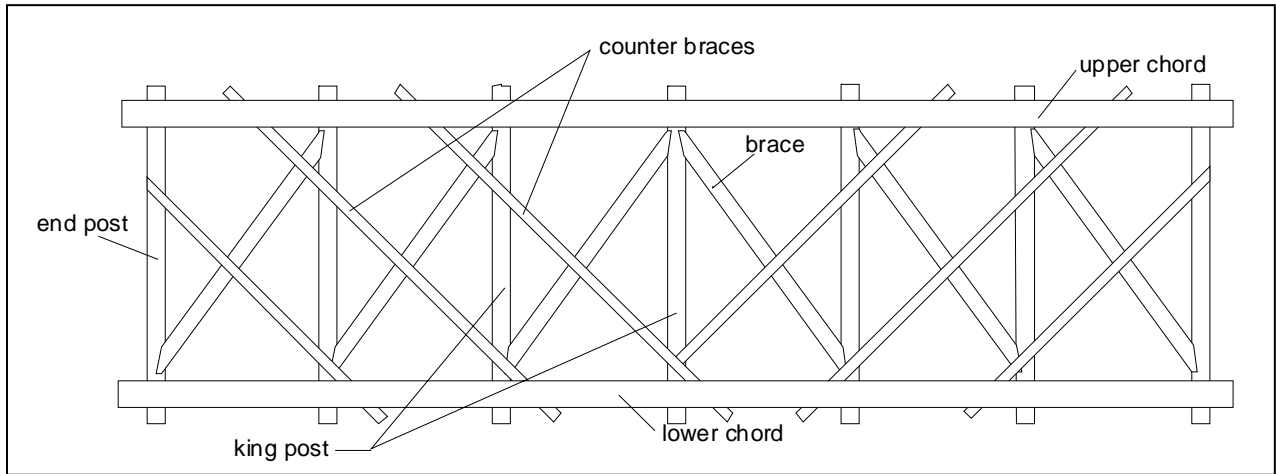

Figure 39. Diagram of Paddleford truss.

There are also a number of covered bridges supported by tied arches (technically not trusses at all). The tied arches are labeled as such due to a horizontal tension element that connects the ends of the arches. The roof and siding are supported by rafter plates and columns above the arches. Rods suspend the floor from the arches.

Chapter 5. Floor Systems

The floor system of a covered bridge is an important element of the bridge, because it supports the loads and transfers them to the trusses. To keep the relationship of floor and trusses in perspective, it is helpful to understand that designers prefer the floor to have somewhat less capacity than the trusses. The trusses are designed with more capacity than the floor so that, in case of an expected overload, the floor will be the first to exhibit distress, avoiding a major failure.

This chapter presents information about the following parts of the timber floor system:

- Floor beams—important transverse elements in the support of vehicular loading.
- Distribution beams—elements attached to the underside of floor beams intended to supplement the floor beams.
- Longitudinal stringers—span between the floor beams (stringers can be eliminated if the floor beams are closely spaced).
- Decking—the component that transfers the wheel loads to the stringers or floor beams.
- Running planks—a sacrificial riding surface on top of the decking found in many covered bridges.
- Replacement floor systems—when the previous floor has been removed entirely and the new floor is independent from the trusses.

It is extremely rare to find a floor system in an historic covered bridge that is still intact from the time of its original construction. At a minimum, the decking is likely to have been replaced several times. Often, the stringers and/or floor beams also will have been replaced. Accordingly, this chapter deals with the various floor conditions and components that are currently found in those bridges. It also presents a number of examples of how floor components are replaced in covered bridge rehabilitation projects.

Figures 40 and 41 depict two of the most common conventional floor systems. Figure 40 represents the basic floor system, a type most routinely found in Town lattice truss bridges. This floor system comprises transverse floor beams and longitudinal decking. Figure 41 represents the more complicated floor system, typically used in queenpost truss bridges, or more generically, all other truss types which have more distinct, separated panel points (unlike the uniform construction of the Town lattice truss). This system results in fewer, but heavier, transverse floor beams. An added element in this system is the longitudinal stringer that supports the transverse decking. The following sections discuss these individual components in more detail. The bulk of this chapter is devoted to the conventional timber floor components. The final subsection discusses some of the various replacement floor systems that have been installed in covered bridges.



Figure 40. Transverse floor beams and longitudinal decking—Fitch's Bridge, Delaware County, NY.

Figure 41 depicts the three-layer floor system of floor beam, longitudinal stringer, and transverse deck (out of view). The extension of the floor beam beyond the face of the outside siding covering of the Pony truss normally supports a strut between the end of the floor beam and the top of the truss to provide lateral support for the top of the truss. An alarming feature of this image is that the struts were temporarily removed to facilitate inspection of the bridge when this photograph was taken.

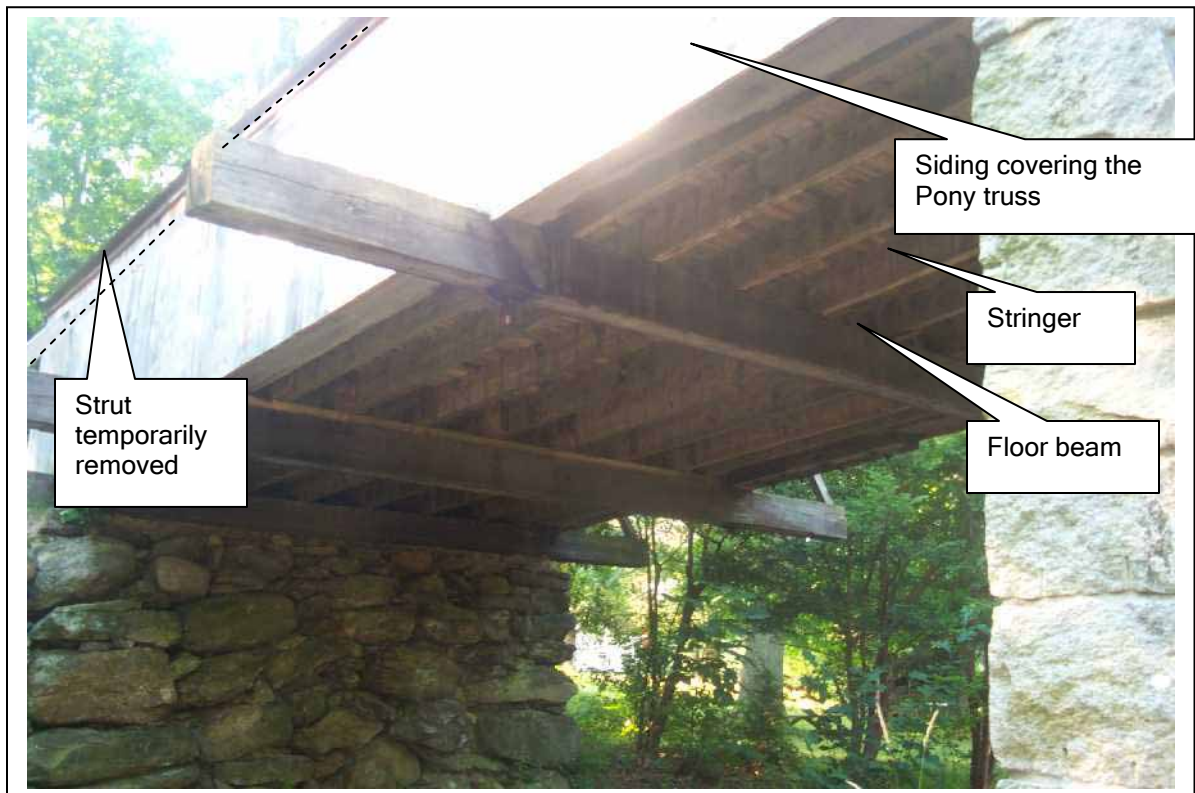

Figure 41. A floor with stringers, floor beams, and transverse decking—Comstock Bridge, East Hampton, CT.

Floor Beams

Transverse floor beams are important members of any covered bridge floor system. As explained in chapter 2, these beams span between the two (or, rarely, three) longitudinal trusses. These beams provide the primary support for live loads by spanning between the trusses.

Bending

Floor beams are subject to two primary stresses: bending and shear. Stress bending is experienced as the beam is loaded. The top fibers of the member are compressed, tending to shorten the top of the beam. The bottom fibers in the member are pulled apart in tension, tending to lengthen the bottom of the beam. Bending stresses often control the design of floor beams made of steel and/or concrete. Timber is relatively strong in resisting bending stresses.

Bending stresses are at the highest near the center of the span of the floor beam, indicating the need for a full beam section there. Some floors contain a bottom lateral system with members that meet at midspan of a floor beam. Often, such connections involve a mortise and tenon arrangement that causes some section loss from the floor beam (see figure 42 for an example of a similar connection at the end of the floor beam). Although the mortise will be located near the neutral axis of the section, the reduced strength of the floor beam can be significant. (The neutral axis of an element is that geometric location within the section that experiences no stress from flexural loading of the section; e.g., for a rectangular element, it is usually located at midheight of the section.) Hence, careful consideration of this situation is advisable, and such details should be avoided, if possible.



Figure 42. Mortise-and-tenon connection in floor beam—Downsville Bridge, Delaware County, NY.

Although there may also be a connection of the laterals nearer the end of the floor beam (as shown in figure 42), or substantial reduction of section due to the notching of the end of the floor beam, the flexural stresses in the floor beam are usually quite small at the ends. These conditions rarely control the sizing of the floor beam, but should be checked.

Shear

The second primary stress type to consider in floor beams is shear. One way to visualize shear stresses relates to the tendency for individual elements within the beam to distort from their originally square shape

to parallelogram (but nonsquare) shapes (technically a rhomboid). This type of distortion is termed shear distortion.

Timber is an orthotropic material; its basic properties vary in relationship to the wood grain direction. In timber, the vertical shear resistance (across the grain of the member) is strong and rarely controls the sizing of the member. However, horizontal shear resistance (along the grain of the member) is relatively weak. It is this along-the-grain shear stress that is tabulated in the allowable stress tables of the NDS. The horizontal shear stress term is used in timber references, because shear forces (and their attendant shear stresses) are generally larger in beams than in columns. The weaker along-the-grain shear component is oriented horizontally in beams designed to resist vertical gravity loads. Shear stresses often control the size of the floor beams. Unlike flexure, which results in the highest bending stresses at the middle of the floor beam, shear stresses are largest near the end of the beam.

Local horizontal shear stresses in a timber beam increase where there is any cross-sectional defect. These defects could be natural, such as shrinkage checks resulting from the normal drying of the wood, or a knot. The defect could also result from the connection details used with the member, such as a notch cut to fit a floor beam into its support location along the truss. Figure 43 depicts the detail used at the ends of most floor beams in Town lattice trusses. Note that both the bottoms and tops are notched. The bottom notch provides a transverse and positive stop against the truss chord. The top is notched to allow the member to fit into the smaller and sloped top openings among the lattice truss members. The combination of these notches can increase the shear stresses in the floor beam sufficiently to require reinforcing the beam at its ends. This is commonly accomplished with vertical, large-diameter lag screws. This method of member reinforcement is not currently included in design specifications; however, the article, "Design of Notched Wood Beams" in the *Journal of Structural Engineering* discuss these issues.^[7]



Figure 43. End notches of floor beams used in a Town lattice truss—West Dummerston Bridge, VT.

Recently there has been some interest in using hardwood timber dowels as a substitute for the lag screw in reinforcing the critical shear planes in the floor beams. The lags tend to rust (even if originally galvanized), thereby becoming both unsightly and less effective. A hardwood dowel can also be less expensive than a galvanized lag screw. Wooden dowels are not mentioned in current design specifications, but various researchers are starting to discuss dowel behavior. Several bridge engineers have used dowels in lieu of lag screws in a few installations where there was confidence that the timber dowel could provide the improvement in shear resistance that analysis indicated to be necessary. Figure 44 depicts use of timber dowel reinforcement of a post against horizontal shear from the vertical component of load in the diagonal. The darker colored chord is pressure treated, while the lighter colored post and diagonal are not. Similar dowel reinforcement of the floor beam is possible. The truss is shown horizontal in this image as it was being constructed on falsework.



Figure 44. Timber dowel reinforcement of post-Mill Bridge, Tunbridge, VT.

Live Load Deflection

Vertical deflections also deserve investigation when considering floor beams. A floor beam adequate to withstand the bending and shear stresses associated with passage of a vehicle could still deflect enough to be noticed by the bridge user. Most design specifications limit the amount of deflection that is permitted in members—for instance, AASHTO specifications indicate a live load deflection limitation of span length (in inches) divided by 500 for timber elements. This deflection limitation can, in some instances, establish that the floor beams should be larger than would be required to resist the shear and bending stresses. In practice, floor beams of covered bridges are often too flexible to satisfy this requirement. Therefore, one must decide if such a serviceability limitation is reasonable or if the limitation can be relaxed. Several practitioners have accepted such a relaxation, but the degree of such acceptance is not known.

Typical Theoretical Weakness of Floor Beams

Somewhat separate from the discussion of the general issues related to floor beams, this section of the manual raises a related topic. That is, evaluation of covered bridges often finds the floor system to be substantially weaker than desired, when compared to current requirements. Many believe that the current specifications are unduly harsh when evaluating the strength of floor beams. This conclusion comes from the fact that a floor beam found to be theoretically weaker than desired often may be functioning successfully, without evidence of distress. Some say that the allowable stresses for shear are too conservative. Others suspect that the load distribution factors for these types of floor systems are too conservative. To date, there is no commonly accepted engineering analysis or practice related to this topic, although many people are pursuing it. Much more research is warranted.

Therefore, if one subscribes to such a belief and resists accepting the verdict of the analysis as taken directly from applying today's specifications, then there must be a consideration of alternative means of assessing the strength and serviceability of the floor beams. This point is reinforced every time recommendations are made to replace seemingly sound and satisfactory existing floor beams.

Consideration of Distribution Beams

Many extant floor systems contain structural elements not part of the original construction. These elements are aligned along the axis of the bridge and are attached to the underside of the floor beams. They typically include a single line of elements along the center of the floor; sometimes there are twin lines along the third points of the floor beams. The members are usually solid sawn timbers and are arranged in a staggered fashion along the bridge with each component continuous under many floor beams.

These elements are identified by a number of terms; a common term is distribution beam. The name derives from the intent of the element to distribute the effect of a wheel load to more than one floor beam. “Distribution Beams” in chapter 12 discusses the analytical issues involved; their effectiveness is debatable. Figure 45 shows an example of a twin line of distribution beams.

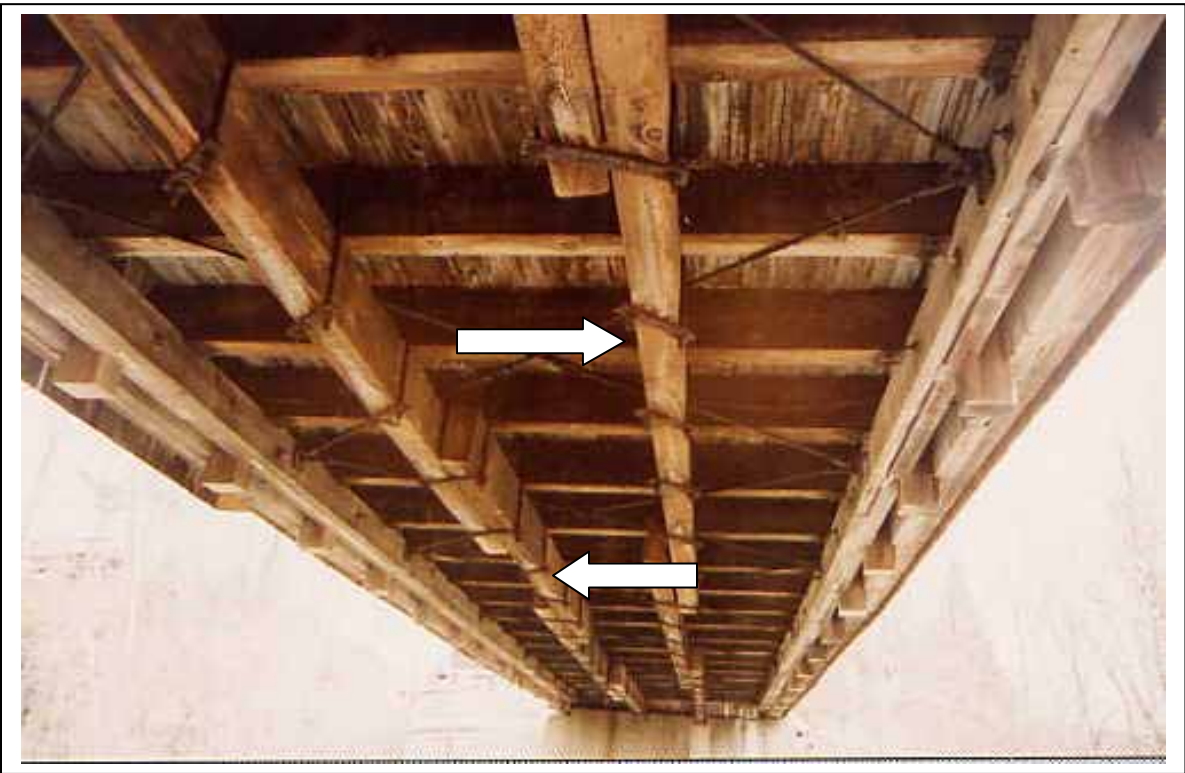

Figure 45. Installation of distribution beams–Union Village Bridge, VT.

The connection to the underside of the floor beam is almost always via steel U-bolts positioned over the top of the floor beam and clamped under the distribution beam, with a steel plate at the downward end of the U-bolt. When a vehicle crosses a floor beam, its deflection forces the distribution beam downward, thereby pulling down on adjacent floor beams; this is why it is called a distribution beam.

In practice, the connections can loosen over time (even if only from shrinking timbers), and the deflection of the distribution beam may become so small as to make its contribution to a particular floor beam suspect.

These beams are often quite stout—up to 203 mm thick by 406 mm high (8 by 16 inches). Therefore, they can add considerable weight to the bridge.

Some engineers believe that these distribution beams are clear evidence that bridge specifications underestimate the capacity of the floor beams. Adding distribution beams is simply intended as a means to increase the distribution of vehicular loads to more members. Yet, comparing the conditions of floor beams in scores of historic covered bridges does not demonstrate improved conditions of the floor beams in those bridges with distribution beams than in those bridges without them.

A study of these components was undertaken as part of the statewide study of Vermont covered bridges during the early 1990s. The conclusion of the study was that the contribution of the components could not be assured; therefore, no benefit from them should be assumed. Further, when work on a particular bridge with distribution beams was undertaken, it was recommended that the beams be removed to lighten the load on the bridge.

Other Issues with Floor Beams

There are several other topics of common interest regarding floor beams.

Floor beams play a vital role in helping the bottom of the bridge resist lateral loading from wind or stream forces. For bridges with intermediate connections to lower laterals in the middle of the floor beams, larger forces can be imparted to the floor beams from such lateral loading, causing transverse (weak axis) bending of the floor beam.

Similarly, traction forces in the deck system (from the braking of vehicles) can also cause additional stresses in the floor beam.

Occasionally, the ends of floor beams have an inadequate bearing area that can lead to crushing of the floor beam. This may be especially relevant to Town lattice truss floor systems for those floor beams that are supported only by the innermost chords.

Typical Floor Beams

Typical floor beams range between 203 to 254 mm (8 to 10 inches) wide and 305 to 356 mm (12 to 14 inches) deep. Some narrow Town lattice bridges, with their multiple floor beams, contained much narrower floor beams to support the originally lighter vehicles. In bridges that require sufficient capacity for heavier vehicles (18 metric tons (MT) or 20 tons), or those that are two lanes wide, reasonably sized solid-sawn members may not be strong enough. In these cases, floor beams made from laminations of dimensional lumber glued together (glue-laminated, or “glulam” beams) can provide more capacity through increased allowable stresses and larger sections.

Stringers

As explained above, some covered bridges have stringers—longitudinal beams supporting load from the decking to the floor beams. The stringers are usually spaced no more than 0.6 to 1.2 m (2 to 4 ft) on center. Stringers only span from one floor beam to the next, with the span limited to 2.4 to 3.7 m (8 to 12 ft). Sometimes, the stringers are long enough to span across two bays of floor beams, making them two-span continuous members. These members are more stiff than simple spans (when the same size as single span elements), and do a better job of distributing live load deflections, particularly when the two-span stringers are staggered with the ends supported by alternating floor beams.

Like floor beams, stringers are sized to resist flexural and shear stresses, and to limit deflection. Shear stresses often control the size of stringers. Member sizes of up to 254 to 305 mm (10 to 12 inches) deep and 100 to 150 mm (4 to 6 inches) wide are common. Stringers are usually single component, solid-sawn timbers.

Decking

As indicated earlier, this discussion is limited to timber decking, which can be of three types: individual planks, nail-laminated panels, or glue-laminated panels. The following summarizes the usual practices for covered bridges decks. The *Timber Bridges—Design, Construction, Inspection, and Maintenance* handbook provides a more indepth discussion of decking typically used for ordinary timber bridges.^[4] There are many similarities between the timber decking used in covered and uncovered bridges, but there are some important differences.

An issue common to all timber decking in a covered bridge is the lack of friction of the road surface. The deck surface inside a covered bridge often becomes slick, and it is common to experience sliding inside of a covered bridge when applying the brakes. There is no commonly accepted practice to combat this phenomenon, yet it is an important issue to recognize. Some choose to install railing constrictions to force slow passage of vehicles in light of this issue. In rare instances, an asphalt-wearing surface is used above the decking for this purpose.

Plank Decking

The simplest and most common deck type uses heavy, solid timber planks. They directly support the wheel loads, and distribute them to the stringers or floor beams. In stringer floors, the deck planks run transverse to the bridge. In bridges with floor beams only, the planks span longitudinally. Planking is routinely 75 or 100 mm (3 or 4 inches) thick, and can be 152 to 305 mm (6 to 12 inches) wide, and up to 3.7 to 4.9 m (12 to 16 ft) long. Deck planks are usually cut from softwoods, like Southern Pine or Douglas Fir. The added dead load applied with denser hardwood planks is rarely justified by load requirements. Planks are usually simply spiked or screwed to the supporting members. Typical transverse plank decking is shown in figure 46. This instance has longitudinal running planks on top along the wheel lines.



Figure 46. Typical transverse plank decking with running planks—Salisbury Center Bridge, Herkimer County, NY.

Some covered bridges have two layers of timber planks, laid at right angles. This is difficult to justify, either economically or from the standpoint of load capacity. There are even examples of bridges with a double layer of deck planks, and a third layer—running planks—on top of those two layers (see “Running Planks” later in this chapter).

Nail-Laminated Decking

A fairly common type of heavier timber decking uses nominal (50-mm (2-inch))-thick lumber, 100, 150, or 200 mm (4, 6, or 8 inches) deep, that is nailed tightly together and in an upright position so that the deck is 100 to 200 mm (4 to 8 inches) thick. This decking system is relatively easy to construct and is, therefore, relatively inexpensive. When the pieces are installed, they are toe-nailed to the top of the supporting stringers or floor beams, and through-nailed between laminae. These decks usually can carry more load than heavy planks, not just because they are deeper, but also because they share load more thoroughly among decking elements and are usually relatively continuous over their entire length. Figure 47 shows a nail-laminated decking being removed during a rehabilitation project.

One disadvantage of nail-laminated decking is that it tends to loosen over time. This negates some of the load carrying capacity and allows dirt and debris to get between the laminations. This can eventually cause gradual deterioration from the intrusion of water, which in combination with the moisture-retaining dirt, creates an ideal environment for decay. Some owners install a full-width layer of running planks on top of the deck to help prevent this situation.



Figure 47. Nail-laminated decking being removed—Fitch’s Bridge, Delaware County, NY.

Nail-laminated decking is usually assembled with pressure-treated lumber, to help protect against early deterioration. Structural grade material (select structural, or No. 1 grade) can provide the strength necessary to properly support design vehicles. Southern Pine is a popular species for this use.

Glue-Laminated Decking

An alternative to the nail-laminated decking is to use deck panels glue-laminated in shops, from 50-mm (2-inch) nominal lumber. These panels are often about 1.2 m (4 ft) wide and may be up to 4.9 to 6.1 m (16 to 20 ft) long. The panel depth is the same nominal 100, 150, 200, or 250 mm (4, 6, 8, or 10 inches). This depth and the higher allowable stresses make these panels effective at carrying loads between widely spaced floor beams. These deck panels are, therefore, usually oriented longitudinally along the bridge. This means there are multiple panels across the width of the roadway. The panels are usually staggered so that the butt joints of adjacent panels are supported on different floor beams. Often, adjacent joints are specified to be at least 1.2 m (4 ft) apart along the axis of the bridge. Panels may be installed transversely over longitudinal stringers.

The panels are usually manufactured of treated lumber and milled on the top to provide a smooth surface. Adjacent and end-butteted panels are often interconnected with blind steel dowels to share loads between panels and decrease differential displacements. Special hardware attachments connect the panels to the floor beams. The pressure treated lumber warrants specifying galvanized or even stainless steel panel connection hardware. Figure 48 shows glue-laminated floor beams and decking system under construction. These panels were fabricated in single units for the full length of the bridge—39.6 m (130 ft) .



Figure 48. Glue-laminated floor beams and decking system under construction—Hamden Bridge, Delaware County, NY.

Running Planks

Traffic will gradually wear away the top surface of any decking. This wear can be significant, especially on softwood decking, so that it would all have to be replaced in a few years, even though the damage is fairly localized. A common practice is to lay down a layer of hardwood planks, aligned only along the wheel paths. These members are intentionally sacrificed to the wear and more readily replaced as necessary, without having to replace the entire deck. A typical installation of twin lines of running planks is shown in figure 49.



Figure 49. Running plank installation—Taftsville Bridge, VT.

Running planks may be positioned along the wheel paths in two separate runs, often 1 m (3 ft) wide, and made of multiple planks in each unit. Occasionally, the running planks are placed in a single full-width layer. The former scheme is less expensive, and tends to slow traffic by helping drivers avoid slipping off the running planks. The latter scheme, in contact, avoids the issue of vehicles slipping off the wheel tracks (which could cause the driver to lose control of the vehicle) and hitting the trusses. The tendency of twin pairs of running planks to slow down drivers is widely recognized as an effective tool to enforce a speed restriction on the one-lane bridge. For those bridges often used by snowmobiles, the issue of the width of snowmobile tracks and skis must be addressed and may lead to the decision to avoid using the

central gap between wheel line strips. Similarly, those travelers using motorcycles must be careful due to slickness of the wood and the instability associated with the drop-off.

Running planks are usually 50-mm (2-inch) nominal thickness and may be treated with preservatives, if desired. Running planks often wear out long before untreated members would rot, indicating that treatment against decay may be an unnecessary expense. This decision should be based, in part, on the expected number of vehicle passages each day. Higher use will require member replacement more often, meaning pressure treatment is more extraneous. Low use might direct the prudent use of decay-resistant treatment.

Replacement Floor Systems

Timber floor systems are fairly regularly replaced, due to deterioration, excessive wear, and/or structural distress after 30-40 years. Occasionally, an owner will install a different floor system than the one originally installed in the bridge. The owner may find that an alternative is apparently less expensive or may provide more capacity than the previous floor system provided. In fact, the floor systems are often the weak link in the bridge's load capacity. This may not be all bad; an overly heavy load might fail some floor components without dropping a vehicle in the river, or without taking the entire span with it. Heavier nail-laminated or glue-laminated decks are generally installed to upgrade the load-carrying capacity from that of the original timber plank deck. Usually, this does not have a significant aesthetic effect on the structure.

In some instances, a deck is replaced in the course of installing a structurally independent bridge system within the shell of the original covered bridge. This can be accomplished by installing two or more steel beams within but below the original trusses with a timber, or even a concrete deck, supported on the longitudinal steel beams. The beams would be supported on independent bearing areas at the abutment, separate from the truss support area. Sometimes the beams are deep enough to show below the bottom of the original trusses. This means that either the roadway surface must be raised to maintain the same low point of the structure elevation (important when the hydraulic opening must not be reduced), or the beams project below the trusses (when there is ample hydraulic opening). Often, the beams are not readily visible and are not objectionable to the traveling public. Many consider this action an effective gutting of the bridge and, therefore, unacceptable. However, it may be the only way to keep the bridge in service. Figure 50 depicts an independent floor system.



Figure 50. Independent floor system—Chiselville Bridge, VT. Note that the pier cap does not support the timber truss, which must still support the weight of the covering and snow.

Recent experience in Vermont indicates that this action would not be accepted in that State, while Pennsylvania continues to allow this reinforcement method. Each State and owner deals with this preservation issue according to local practices, customs, and resources.

This action, when completed, separates the timber trusses and covering from the support of vehicular loading. Hence, routine bridge inspections (mandated by the Federal Government every two years) will focus on the main supporting members (steel beams and decking) and may pay less attention to the trusses and covering. Eventually, serious deterioration may become more pronounced and avoid detection until collapse of the covering onto the beam bridge is imminent. This represents a significant safety concern for the users of the bridge and a potential loss of an historic bridge.

An important issue relates to the connection of the shell to stabilize the bottom chord of the truss. A horizontal connection of the bottom chord of the shell is required to provide resistance to wind loading against the sides of the shell. However, the independent structure will deflect vertically under the influence of vehicular traffic. The unconnected shell will not deflect from that live load. Conversely, the shell will deflect from the influence of snow loading while the independent structure does not. Hence, if

one attempts to join the bottom of the shell to the independent structure, adequate vertical differential motion must be accommodated. Further, if this connection binds over time, it can pull the bottom chord of the shell apart and destroy the shell. Therefore, this requires extreme care in detailing the connection.

Chapter 6. Ancillary Features

This chapter deals with several important bridge components, though these are ancillary to the main trusses and floor system. These ancillary features include:

- The roof—including its appearance, geometry, materials, and structural support.
- Portals—the entrance of the bridge.
- Siding—including modifications during subsequent rehabilitation of the bridge.
- Bracing—very important to a covered bridge and often found to be inadequate in extant covered bridges.
- Railings—a topic that warrants special consideration for historic covered bridges.

It should be noted that there is no correct or recommended practice for many of these topics. Historic preservation issues prevent significant alterations from those of the original construction. For example, a bridge built with a flat roof and no portal extension would not be rebuilt with a gabled roof and portal extension. Accordingly, the discussion here aims to document engineering and construction issues related to an inherited feature. In instances where changes can be made—notably the railing system—recommendations are offered.

Roof

Of all of the ancillary features of a covered bridge, the roof may be the most important, because it is the first line of defense against the detrimental affects of weather. Yet the complete system is quite involved, with many individual aspects deserving attention.

Style

Covered bridges have diverse rooflines. By far, the most common roof style is the gable configuration (see figure 51). Yet, even in this simple form, the slope can vary from very nearly flat to quite steep. The side overhang can vary from short to moderate. In elevation view, the roof ends are usually cut at right angles to the axis of the bridge (or plumb), while a few extend to a point over the entrance of the bridge. Perhaps the most recognizable roof form is the flat-roofed bridge of film fame, from “The Bridges of Madison County.” Figure 52 presents a flat roof bridge in Madison County, IA.

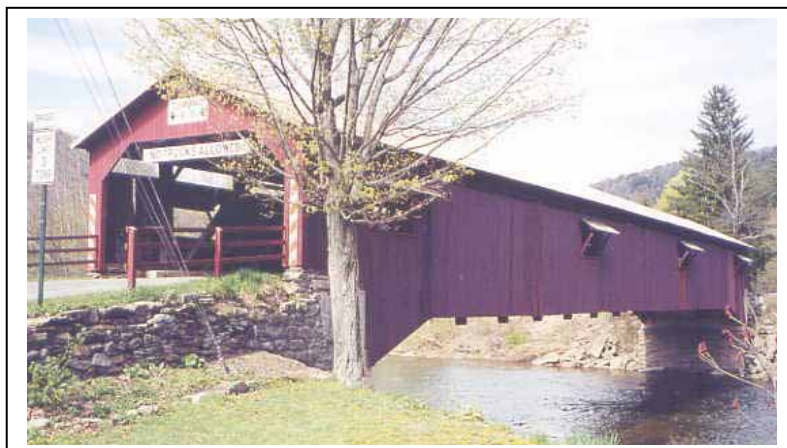

Figure 51. Classic gable roof—Forksville Bridge in Sullivan County, PA.



(photo courtesy of Abba Lichtenstein)

Figure 52. A flat roof bridge—Hogback Bridge, Madison County, IA.

Materials

The statewide Vermont study (noted earlier) identified the following distribution by material types:

- 80 percent had a metal roof.
- 10 percent had wood shingles.
- 5 percent had asphalt shingles.
- 5 percent had slate (longer-lasting, but heavier).

This represents the largest survey of roofing materials on covered bridges in a large geographic area and is informative, although not necessarily indicative of other areas.

Preservationists tend to prefer wood shingles, because wood generally would have been used on the original construction. However, metal roofing can represent important advantages to the covered bridge engineer, because it tends both to reduce the dead load and to help shed snow loads much faster than any other material. As explained in chapter 11, snow loads often represent a significant load on a covered bridge. Avoiding large snow accumulations, especially asymmetrical snow drifts, helps to preserve bridges for longer periods with reduced major rehabilitation needs. For these reasons, it is recommended that metal roofing be used for replacements in areas of snow.

Roof Boards

The roofing material typically is supported on roof boards that are, in turn, supported on rafters. As might be imagined, a very diverse assortment of roof boards (or nailers) has been installed on covered bridges by original builders and by all subsequent maintainers. Generally, however, one finds nominal 25-mm (1-inch)-thick boards that may be spaced either tightly or with gaps. Plywood sheathing is rarely used. In part, the roof board type and spacing depend on the type of roofing material (e.g., wood shingles require nailers that are more regularly spaced than metal roofing).

Rafters

Configuration

The rafter configurations on covered bridges are almost always similar. For the conventional gable roof, the rafters are invariably single pieces on each side of the ridge. Rafters vary in size, with the most common dimensions of 50 to 100 mm (2 to 4 inches) wide by 100 to 150 mm (4 to 6 inches) thick, and on-center spacing ranging from 610 to 915 mm (24 to 36 inches). Most rafters overhang the outside edge of the truss, anywhere up to 0.6 m (2 ft) on either side. The rafters are usually notched where they bear on the truss top chord (“bird’s-mouth”) and are toe-nailed to the truss.

The peak of the gable roof may have a ridge pole, a board or plank member that runs the length of the roof, at its peak. The rafters butt against it from either side. This ridgepole can be omitted, leaving the rafters butting against one another at the ridgeline.

The typical gabled roof slope varies, but is usually about a ratio of one unit vertical to two units horizontal, or 6 on 12. A steep roof would be 12 on 12; a so-called flat roof would be only 2 or 3 on 12.

Ties or Struts

Often, a horizontal member is attached between opposing rafters, at about their midheight from the truss top chord to the peak. These members are commonly called rafter ties, which imply that they are loaded principally in tension. Yet many builders install them to reduce the sag in otherwise undersized rafters, which would require their being loaded in compression and more properly called rafter struts. This basic misnomer is typical of the general confusion about how these members behave in roof structures. The basic axial load issue—tension or compression—is a direct function of the lateral restraint available at the rafter bird’s-mouth connection. If the rafters are restrained laterally by firm connections to sufficiently rigid timbers, the rafter strut is in compression and reduces sag while increasing the outward thrust at the bird’s mouth. If, on the other hand, the rafters are free to spread at the bird’s-mouth connection, the collar tie is in tension and is responsible for holding the roof together. This is achieved at the cost of increased bending (and the attendant sag) in the rafters.

One underappreciated effect these members can have is in mitigating the impact of unbalanced snow loads. If a snowdrift builds on one side of the roof, then the rafter beneath it sags and pushes the opposite side of the roof, through the intervening rafter strut, in a way to help share the unbalanced load between the two rafters. Sometimes the ties are used on every rafter; other times they may not be present on all rafter pairs—perhaps on only every other or every third rafter.

Rafter ties certainly are not mandatory, and many roofs do not have them. It seems to be more a matter of individual preference on the part of the engineer or builder, yet the advantages of rafter ties outweigh their cost, and they are recommended. Figure 53 presents an example of rafter ties at midheight of the rafters. These are the horizontal members above the X upper laterals in the foreground.

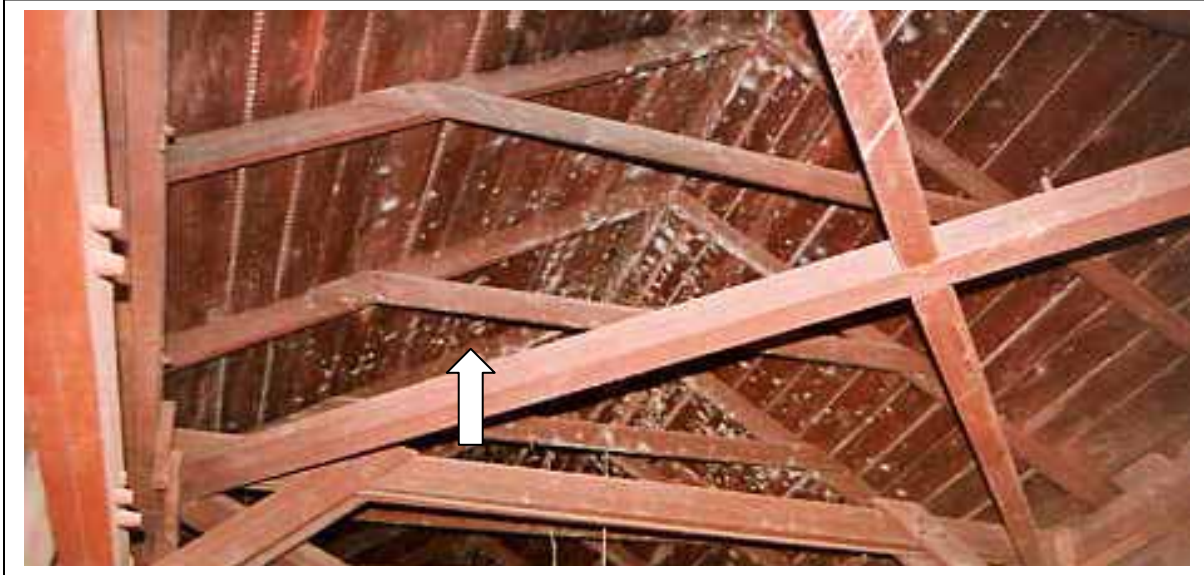

Figure 53. Example of rafter ties—Northfield Falls Bridge, VT.

Engineering Challenges Related to Rafters

It may seem odd that something so seemingly inconsequential and straightforward as a rafter can be such an analytical challenge to the covered bridge engineer. The rafter design strongly depends on its assumed span length. If the designer/analyst does not use rafter ties or struts, then it is fairly clear that the span of the rafter is between the support on the truss top and the peak. Yet, the analyst must be careful. The design is predicated on compatible loading and span length. If one uses the length along the slope of the roof, then one must use a load value that is at right angles to the rafter (or the component normal to the roof plane). If the analyst is using globally projected vertical loads, then the horizontal component of the length must be used to be compatible. A common mistake is to use globally projected vertical loads and span lengths measured along the rafter. While this is not compatible, it is fortunately conservative (i.e., this methodology leads to larger rafters being required or specified).

If the designer includes rafter ties, then is the rafter span only the longest of the two sections? On first inspection, this might seem to be so. Yet, the rafter tie (or strut) essentially converts the simple span behavior of two independent rafters on opposite sides of the roof into an interconnected unit that functions as a frame. Now, with the tie in place, snowdrifts can induce frame behavior, and the assumed support condition at the trusses becomes crucial. Does one assume that the trusses are fixed horizontally (in which case, the rafter frame is restrained against deflecting outward at the ends), or does one assume the trusses may spread apart under roof loading, so that the rafter ends are allowed to settle outward? In this latter case, the bending stresses in the bottom surface of the rafter frame would increase substantially.

Are rafter frames always restrained from horizontal motion at the truss tops? Yes, if a properly designed and detailed top chord horizontal bracing system exists, because the trusses are restrained at the point of connection of the bracing. Additional questions also arise: Can the trusses deflect outward between brace points? What bracing is both sufficiently stiff and strong to provide and to resist the horizontal support component?

These are interesting points for the engineer to ponder. Each situation is different and requires a site-specific evaluation according to the strength of the bracing system and lateral strength of the truss top chord. Therefore, the rafter analysis that at first seemed straightforward becomes a little more involved.

In general, it usually is sufficient to size rafters based on simple span behavior, regardless of whether or not a rafter tie is used. Attempting to analyze the rafter combination with tie or strut more accurately may even lead to erroneous results, if some of the more complex support issues cited above are mishandled.

Rafters should not be designed without considering these consequences. When replacing rafters, engineers should size them according to proper design techniques. However, historic preservation of rafters that may be in good condition otherwise, regardless of theoretical overstress, may be desired. This discussion highlights the various issues related to these elements.

Portals

The portal of a covered, or any other through bridge, is its entranceway or opening (or the end elevation view), comprised of the sides and roofing. Covered bridge builders have provided plain portals or more ornate portals with special architectural treatments and enhancements. An example of unusual detailing of a roof portal, finished more like a house than a bridge, is shown in figure 54.

In large part, the portal represents a nonstructural detail; the designer or builder may simply provide what the owner desires. Very few covered bridges have included especially stiff and strong lateral load bearing elements in the portal detailing. This is not a conservative method—how is the entire lateral load carried in the top chord lateral bracing finally transferred down to the abutments, if not through some particular portal bracing? The knee braces can transfer the loads down to the floor level bracing along the span. The flow of the lateral forces, applied to the upper half of the central zone of the span, usually is resisted by a complex combination of knee bracing and transverse bending in the truss elements down to the deck, and top chord bracing longitudinally to the ends.



Figure 54. Unusual detailing of a portal—Upper Falls Bridge, Weathersfield, VT.

Some bridges contain a separate panel of structure before the beginning of the actual trusses. This feature is often termed a portal extension, or shelter panel. It helps protect the ends of the trusses from wind-blown rain. An example of a portal extension that protects the ends of the trusses from weather damage is shown in figure 55 (see also figures 14, 15, and 16).



Figure 55. Example of portal extension–Wehr Bridge, Lehigh County, PA.

Siding

Covered bridge siding can be full height or only partial. Often, the siding is stopped well below the eaves to provide better ventilation through the bridge. This gap can also introduce natural lighting, at least during the day. Sometimes there is a larger gap at the top, such that the siding covers only the bottom portion of the trusses. In some cases, it may even be short enough to allow passing motorists to look over the top of the siding; such a bridge offers a continuous window to users, albeit with reduced weather protection.

The siding is usually rough-cut softwood, either painted, stained, or untreated. In these cases, the siding is installed vertically. Sometimes the siding also includes “battens” (narrow boards over the gaps of the main boards), but usually the gaps are left open.

More elaborate siding is installed on some covered bridges, either vertically or horizontally, in which case the siding is often painted. Rehabilitating bridges with special siding often requires that the siding be removed carefully so that it can be reinstalled and repainted.

Many bridges contain openings (windows) in the siding. The windows may be quite small or large, depending on the preference of the owner, designer, or builder. The windows provide additional light inside the bridge to facilitate safe daytime passage. They also often provide fishing access. At many bridges detailed without windows, vandals break boards to gain such fishing access. This behavior seems so widespread that wise detailers install windows when rehabilitating a bridge, even if it did not previously have them. While the windows expose surrounding timber to the effects of windborne rain, significant rotting of primary timbers around these windows is quite rare, provided good trim details are used (ones that foster rapid drainage and do not trap any water). Many bridges have windows only on one side.

At some bridges, the siding extends on the inside at the ends, for distances up to 3 m (10 ft). This internal siding is identified by various terms, as noted in chapter 2, but the most appropriate term is shelter panel.

This siding protects the ends of the primary structural members from splashing water from vehicles and windborne rain. The inside siding can effectively protect the timbers, but it also makes it difficult to perform routine visual inspections in that portion of the structure. Further, the reduced ventilation around the truss members may actually accelerate rotting of the timbers.

There is some controversy regarding siding, from the perspective of historic preservation. Some believe it is very important to replace siding, when necessary, with virtually identical materials and details, including maintaining the same preservative treatment (paint, stain, or no treatment). Others believe that the siding is less significant from a preservation perspective, since it almost always has been replaced at least once during the life of an historic covered bridge.

Therefore, some choose to modify the siding details to provide improvements as deemed necessary during subsequent rehabilitation of the bridge. Such improvements might include better detailing around windows to reduce exposure of truss elements, or battens might be added where not used before the rehabilitation. Some also use 50-mm (2-inch)-thick siding specifically to lessen damage from vandals. Modern siding installations often rely on the use of stainless steel screws rather than smooth shank nails as an improved means of vandal protection.

Bracing

Bracing is vital to the structural well-being of covered bridges (as with almost all structures). Chapter 2 introduced the various bracing components, in the nomenclature subsection. This subsection offers additional engineering information related to bracing.

Upper Chord Tie Beams

Transverse tie beams connect the tops of the two longitudinal trusses. They are often larger sawn members, up to 200 to 300 mm (8 by 12 inches), to accommodate the joinery details with the lateral braces. The tie beams are anchored to the top of the trusses, often with vertical bolts. They are usually notched across the top chord to provide an additional and positive stop against transverse displacement at the top chords.

Lateral Bracing Systems

The lateral braces at the top chord level are usually at least 100- x 150-mm (4- x 6-inch) members and are usually joined to the transverse tie beams with mortise-and-tenon connections. Instead of being pegged, these connections are usually tightened with matched wedges to keep the system tight. This means that only those braces that are oriented to be loaded in compression will be working. The wedges cannot transfer any tension forces from the braces to the tie beams. Figure 56 depicts a typical connection of lateral braces (complete with painted markings from 1885 when this bridge was relocated to its current location) with the light-colored tie beam replacement. The light-colored matched wedges (shown transversely in this view) can be driven against each other to keep the system tight. At the intersection of the lateral X-braces, there may be a vertical bolt, and there might be a matching dado notch cut into both members, to ensure that they are flush and in plane. A common feature of lateral X-braces is that the end mortise-and-tenon connections are cut so that the lateral X-braces must be slightly bowed around one another, to fit into the connections. This bowing adds resistance to potential loosening of the laterals, by inducing some friction forces along the top and bottom surfaces of the joinery. The pretensioning also helps to prevent rattling overhead.

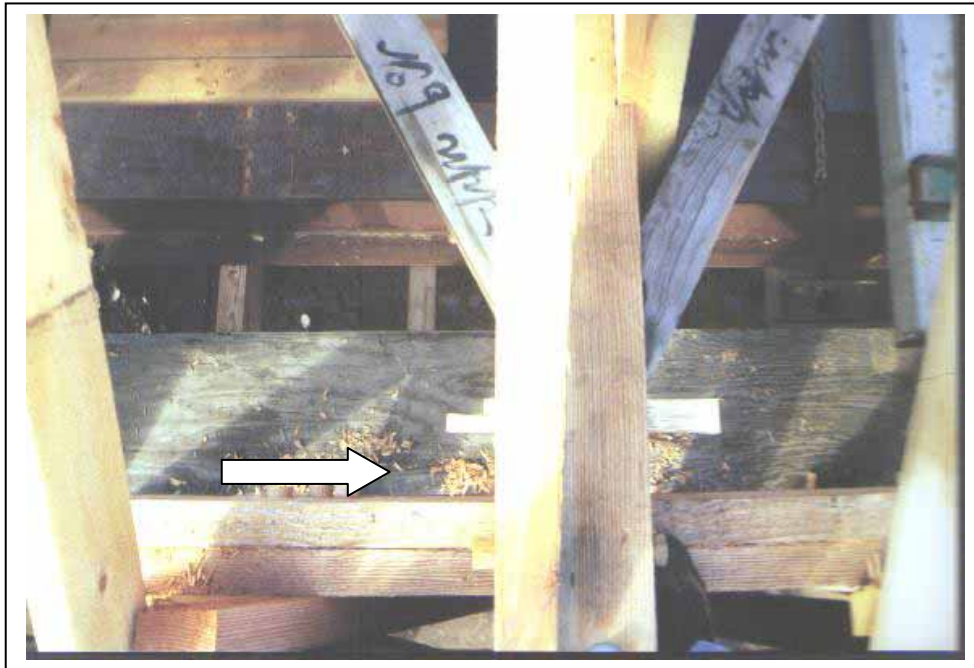

Figure 56. Lateral brace connection at tie beam—Fitch's Bridge, Delaware County, NY.

Lower lateral braces are more controversial than upper bracing systems, from an engineering analysis perspective. Most bridges were built with these members in the original floor system. Original floor systems often included longitudinal stringers in addition to the decking and transverse floor beams. In the three-layer system, the lower lateral braces maintained strength and stiffness at floor level against wind loading. Because most floor systems have been altered or replaced during the life of the bridge, the current floor system may not present the original conditions. These lateral bracing members are even more commonly omitted in recent renovations, because modern floor systems usually include only two layers of floor members—the decking and the floor beams. In these floor systems, the decking can be detailed to provide a more direct diaphragm action, and the need for the lower lateral braces is reduced. The lower lateral braces are traditionally attached to the floor beams with heavy spike toenails. Occasionally, mortise-and-tenon connections are used, very similar to those found in the upper lateral bracing system. One reason not to use traditional mortise and tenon joinery in the lower bracing system is that most heavy transverse floor beams are nearly critical already, without taking net section away with mortises for the X-braces.

Knee Braces

The detailing that connects transverse plane knee braces is varied and depends on personal preferences of the engineer and builder. Chapter 12 contains a discussion of the analysis of bracing systems and the knee braces. This subsection is directed more to the general arrangement of the members and typical sizes thereof.

Many bridges contain short members (knee braces) connecting the underside of a tie beam to the side of a vertical truss member or to the intersection of the lattice planks in a Town lattice truss. These knee braces typically do not have any substantial connection capacity in tension. The consequence of such a compression-only system often is distortion and racking in the bridge.

Figure 57 depicts a traditional knee brace. Note the mortise-and-tenon connection to the tie beam and to the side of the post.

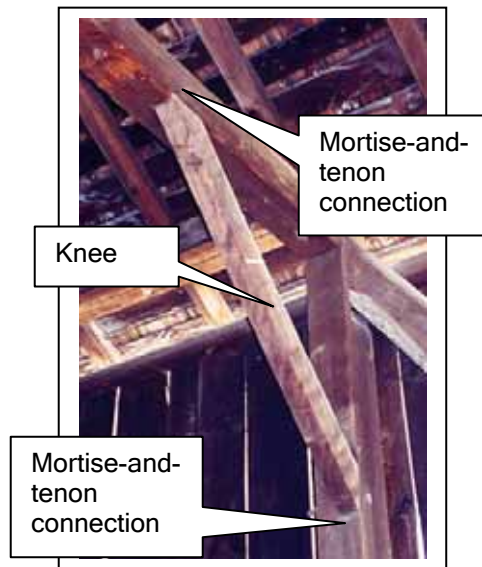

Figure 57. Traditional knee brace—Salisbury Center Bridge, Herkimer County, NY.

More recent rehabilitation projects of historic covered bridges have occasionally modified the knee braces to make them stronger and stiffer. One popular means is the use of heavier members, with extensions above the tie beams up to the rafters beyond, to form a transverse frame, as shown in figure 58. Note the longer component, projecting above the tie beam, and connected to an upper strut member, effectively making the pair of knee braces into a much stronger frame.



Figure 58. Alternative and stronger style of knee brace—Hamden Bridge, Delaware County, NY.

In some instances, an additional metal rod is added above the knee braces and detailed to add extra tensile capacity to the members. Figure 59 depicts such an example. Note the metal rod positioned above the timber knee brace that penetrates through the tie beam and the intersection of lattice elements. The rod adds tensile capacity to the knee brace system.

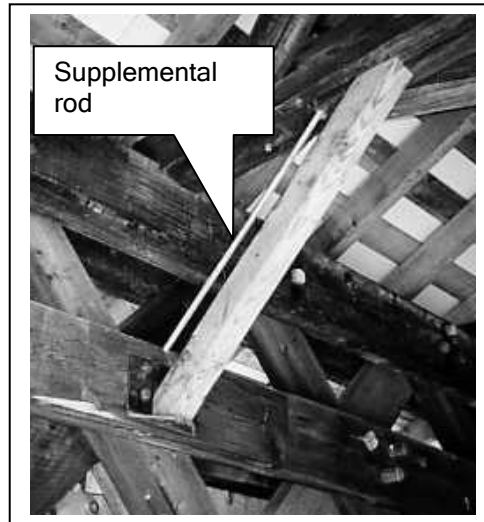

Figure 59. Another alternative knee brace—Hopkins Bridge, Enosburgh, VT.

Check Braces

The posts of Burr arch trusses and some other configurations are subject to substantial bending forces due to the geometrically necessary separation of the horizontal forces between diagonal and chord. Many bridges were built with check braces to help strengthen the post. Figure 60 depicts a classic installation of a check brace at a bottom chord connection to the post. In this installation, the lighter colored post has been replaced. The new check brace on the right side of the post is notched into the top of the bottom chord and resists the horizontal component of force in the diagonal notched into the left side of the post. Figure 61 depicts a check brace at a top chord, on the far side of the post backing up the horizontal force in the diagonal on the near side of the post.

Unfortunately, check braces commonly were removed during subsequent rehabilitation of bridges and not reinstalled. These elements are important and must always be reinstalled if removed. Further, in those bridges that do not have them and may not have had them initially, rather than simply strengthening the posts or replacing them with larger elements, this form of bracing element is a good retrofit option to strengthen posts that are overloaded,.

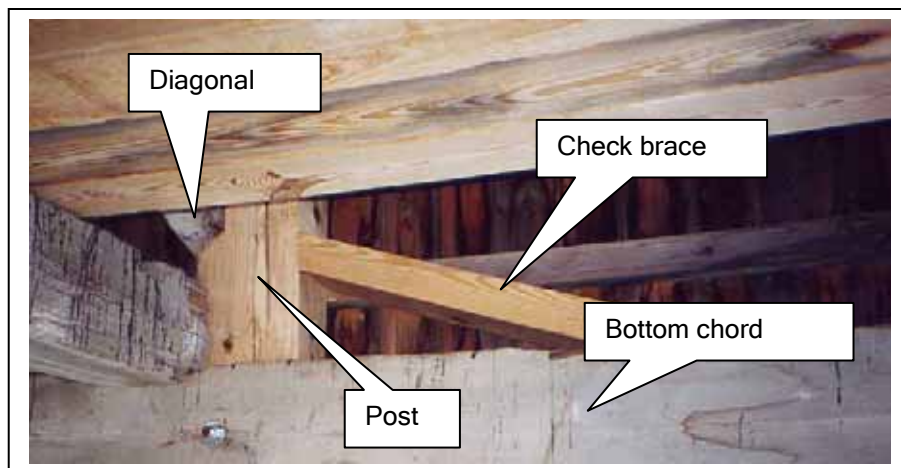

Figure 60. Check brace at bottom chord—Brown's River Bridge, Westford , VT.



Figure 61. Check brace at top chord—Quinlan Bridge, Charlotte, VT.

Chin Braces

An example of bracing common to a geographic area is a chin brace. Many of Georgia's Town lattice trusses are fitted with a timber brace at each inside corner that projects from the top of the foundation, past the inside of the lower chords, to the inside of the top chord. Its angle is steep, limiting its strength as a bracing element and making its connections vital to its function. Refer to figure 62 for a typical example. Due to their immediate proximity to vehicular traffic, these elements are susceptible to impact damage. These elements are sometimes used in lieu of knee braces.

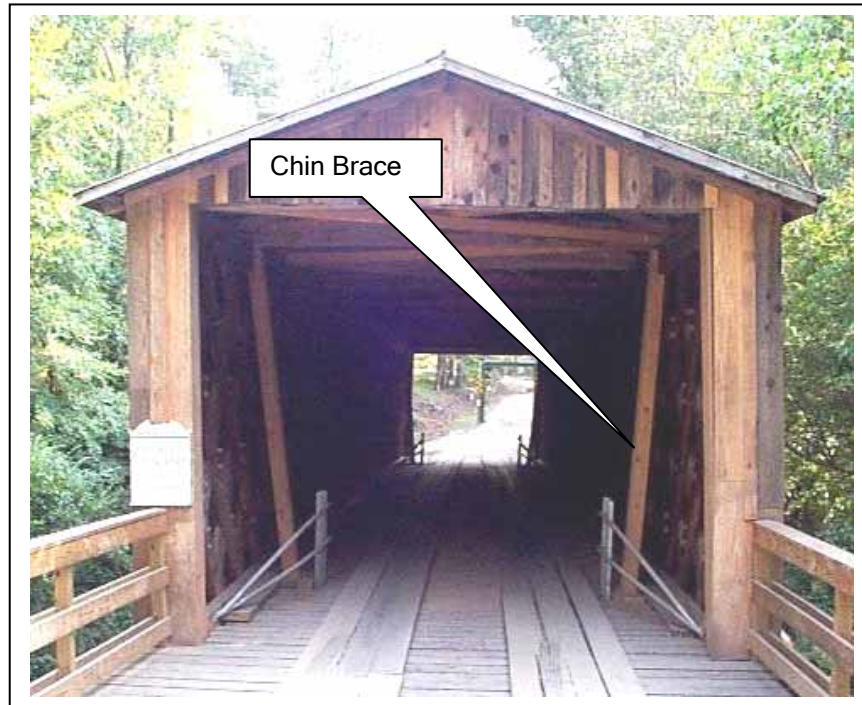

Figure 62. Chin brace—Elder's Mill Bridge, Watkinsville, GA.

Traffic Railing

Railing systems are a necessary part of modern highway design; they increase safety for the traveling public. The bridge railing system includes the railing on the bridge (bridge railing) and the railing on the approaches leading to the bridge (approach railing).

The Federal Highway Administration (FHWA) requires that crash-tested railing be used on all National Highway System (NHS) highways. For secondary roads, the State's and/or bridge owner's standards and policies should be followed. Historic covered bridges are only rarely, if ever, located on the NHS.

Virtually no historic covered bridge has ever had internal bridge railings, and most of them do not have an adequate approach railing system. Hence, the standard approach to bridge rehabilitation projects for conventional bridges, which involves installing a standard railing system, has often not been followed on covered bridge projects.

Bridge Railing

With respect to bridge railing, review of numerous recent projects prepared by various engineers at random locations across the United States demonstrates a range of treatments, from no railing at all to simple timber curbs, to a few installations using much heavier railings. The lack of standardized bridge railing for historic covered bridges has often been accepted because of the relatively low speed of the vehicles passing through the bridge and the lack of space for such a railing. An inspection of most covered bridges demonstrates that few collisions with truss members have occurred during the life of the bridge.

However, the use of a timber curb is a good addition to a bridge without any other protection, because most vehicles will not mount or cross over such a curb, and it can be bolted to the decking. The curb should be raised with timber block spacers to avoid long areas of curb directly on top of the deck, which would trap moisture and promote early deterioration of both curb and deck.

In those bridges with separate running planks along the wheel paths, the planks tend to channel the tires of a vehicle that has wandered off of them while guiding the vehicle through the bridge without danger of contact with the truss members. In these instances, the use of a raised curb is still recommended.

Figure 63 shows an example of inside curb traffic protection. While not meeting the provisions for railing protection of more modern bridges, this type of application may be prudent and practical for rehabilitation of historic covered bridges.



Figure 63. Interior curbing—West Dummerston Bridge, VT.

While some owners have adopted crash tested railing policies for building or rehabilitating other types of bridges, the use of such a railing system may typically be out of character for the rehabilitation of a historic covered bridge. Yet, the U.S. Forest Service (USFS) and FHWA have developed a number of crash-tested bridge railings for use on modern timber bridges. Some of those railings may be adaptable to covered bridges.

Approach Railing

The accepted practice is to require more substantial railing for the approach to a covered bridge.

Many owners of covered bridges would object to the use of traditional galvanized metal railing, even for the approaches, due primarily to aesthetic dissimilarities between galvanized rails and timber bridges. In some instances, metal railing systems made of weathering steel have been used, on the basis that the aesthetically pleasing rusty patina is more compatible with the covered bridge. Some continue to use only timber railing systems.

An important aspect of railing for covered bridge projects is protecting the end of the trusses. As discussed above, it is rare when a true bridge rail is installed inside of a covered bridge; therefore, the approach rail must be terminated at the entrance to the bridge. In instances with internal curbing, the transition from approach rail to curb should be carefully aligned and detailed to adequately protect the end of the truss. Some approach geometrics will require more attention than others, depending on the specifics of the site.

An alternative approach railing system is depicted in figure 64. The tight squeeze (2.6 m (8.5 ft)) is very effective at eliminating larger vehicles and forcing slow passage.



Figure 64. Squeeze timber approach railing—Hamden Bridge, Delaware County, NY.

Figure 65 shows another recent bridge rehabilitation using a standard approach guiderail with timber curbing inside.

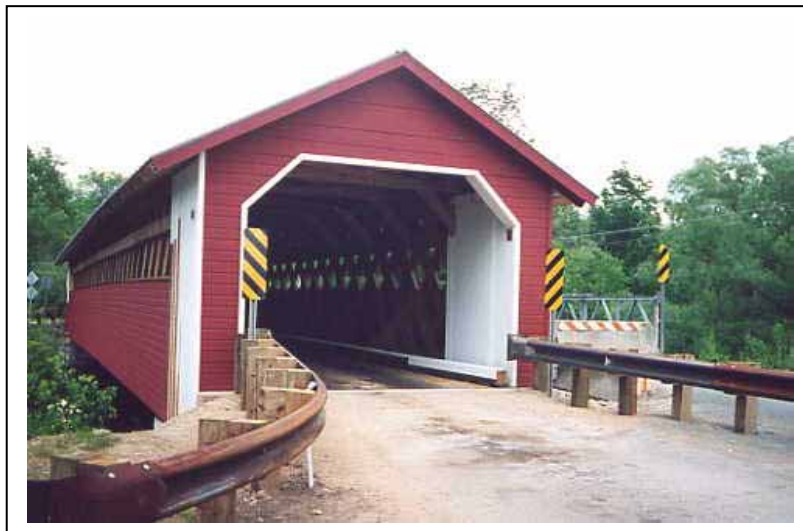

Figure 65. Approach railing and bridge curb—Paper Mill Bridge, Bennington, VT.

The transition from approach railing to bridge curbing can be highlighted with a reflector. Figure 66 presents a view of one such installation. This bridge provides for pedestrian traffic outside of the curb (but inside the bridge), and the gap between approach railing and curbing allows that passage.

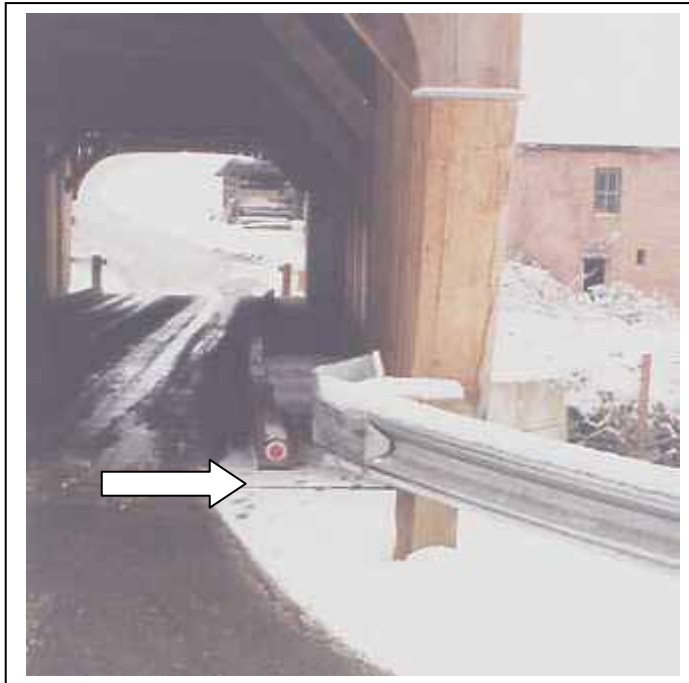

Figure 66. Transition from approach railing to inside curb—Mill Bridge, Tunbridge, VT.

Because each bridge is unique and the specific nuances of railing systems for historic covered bridges remain unclear, this manual urges careful consideration of the matter and the use of prudent engineering and construction details for work on historic covered bridges.

Chapter 7. Foundations

Covered bridges are no different than other bridges when it comes to designing foundations for new structures or replacing abutments for existing bridges. This process requires soil borings, evaluation of bearing pressures, rock (if encountered), evaluation of the need for piles, and scour protection. This chapter focuses on the evaluation of existing foundations, and remedial action as required.

Types of Foundations

Most covered bridges are single-span structures with two abutments, one on each bank of the stream. Piers or bents, when present, are placed between abutments. Almost invariably, covered bridge abutments built in the 19th century were made of stone that was either mortared or laid dry (without mortar). Many of those foundations remain in service today. Figure 67 depicts a relatively tall stone abutment in good condition. In other cases, the stone foundations have been replaced or faced with concrete.



Figure 67. Original stone high abutment in good condition—Upper Falls Bridge, Weathersfield, VT.

The piers of bridges with more than one span may have been built with the bridge and are probably of stone masonry, or they may be more recent additions to the structure. Piers added after the original construction may be timber or steel bents, or they may have been concrete structures. The bents often are made of piles (usually three or more, in clusters) driven beneath both trusses with a cap (horizontal member) connecting the tops of the piles. The cap might be directly beneath the bottom chords of the trusses, or additional blocking might be installed as a fill. These bents were added in reaction to perceived or visible weakness in the original structure. An example of a retrofit bent is shown in figure 68. These groups of old telephone poles were not especially sturdy, but helped support the Hamden Bridge in Delaware County, NY, for many years. They toppled easily when removed as part of the recent bridge rehabilitation.



Figure 68. Supplemental pile bents—Hamden Bridge, Delaware County, NY.

Adding these bents was probably considered appropriate and viewed as a permanent feature. More recent attention to historic preservation often views such actions as a quick, nonpermanent, superficial fix to help restore the bridge's capacity, but these remedies are not usually considered an acceptable long-term solution. It must be recognized that, in addition to altering the historic and visual characteristics of the bridge, introducing the bent changes the behavior of the trusses and often causes major distress in the truss elements.

The vast majority of the original covered bridge abutments were constructed on a base of stones that served as a footing. The bottom of the abutment was dug to a depth below the streambed, with the water diverted or separated from the foundation pit. Then a base was built with plan dimension larger than the main portion of the abutment. The base was usually built with larger stones, or even concrete. Then the stem or breastwall of the abutment was constructed to be large enough to spread the load over an area of soil, resulting in a base pressure that the soil could resist without a slide, slip, or overturning failure.

At the sides of each abutment (upstream and downstream), wing walls were built to retain the soil of the approach embankment. The wings may be at right angles to the abutment stem, or they may be flared, depending on the builder's preferences and the geometry of the bridge with respect to the abutment. The original construction of the wing walls would have used the same material as the abutment stem (i.e., usually stone, also supported by spread footings). Figure 69 illustrates the difference between wing wall and abutment stem. The abutment stem is the portion directly beneath the timber structure. The wall to the left (old painted sheet piling) and the old stone wall to the top right serve as wing walls to retain the approach fill from spilling into the river. This is from Fitch's Bridge in Delaware County, NY, before its recent rehabilitation.

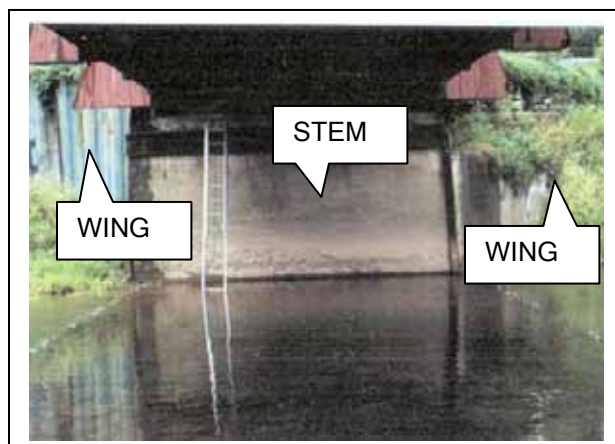

Figure 69. Abutment stem and wing wall identification.

In many instances, the bottom layer in a spread footing would have been a layer of timbers, trees, etc., as a means of making a platform on a muddy bottom. As long as this timber was continuously underwater (or below the water table), it did not rot; these components are often found intact when abutments are replaced. Mud sill is the most common term for this type of initial layer.

In instances where the native soils at a bridge crossing were considered to be less stable, timber piles would be driven to support the weight of the abutment and bridge, vehicular live loading, and overturning forces of the earth pushing the abutment towards the stream. This piling usually consisted of peeled wooden poles, up to 300-375 mm (12-15 inches) in diameter and as much as 9.1-14.2 m (30-40 feet) long. The piles would have been driven at spacings as close as 1-1.2 m (3-4 ft) in plan view.

Modern foundation technology, applied to the same design, would use concrete exclusively in lieu of stone masonry; the piling could be timber, steel, or concrete.

Some abutments in more scour-prone areas have been protected by larger stones (termed rip-rap) along the face of the stream banks and directly in front of the abutment.

Common Conditions of Foundations

In many instances in which covered bridges survive with exposed stone masonry abutments, a layer of concrete has been installed over the stone, beneath the timber structure. This layer of concrete is referred to as a cap. The cap tends to knit the stone together and helps distribute the loads of the timber structure and vehicles over more of the abutment. It would usually have a vertical wall behind the horizontal bearing surface to keep the approach fill from spilling around the ends of the trusses. Often, by the time rehabilitation of the covered bridge superstructure is required, the added concrete cap also has deteriorated to such an extent as to require replacement.

The remaining stone masonry may contain cracked stones, perhaps even shifted stones, indicating failure of the stone against the lateral earth pressure. The cracked stones are often the result of differential settlement of the foundation or mud sill. Figure 70 presents an example of badly cracked stones in the bottom of an abutment stem. This condition precipitated removing the bridge from this abutment and completely replacing it.

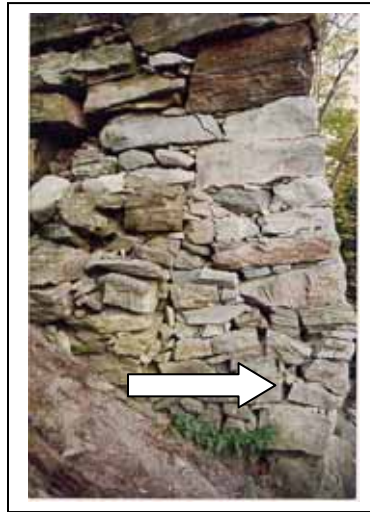

Figure 70. Badly cracked and shifted stones in the bottom of an abutment stem—Halpin Bridge, Middlebury, VT, before its replacement.

In many cases, a concrete facing has been cast directly against the stonework. Depending on the details of the work, the stonework may either be completely hidden or left in some detectable form. In other cases, the joints of the stone masonry may have been pointed (filled at the surface) with mortar, the entire surface may have been parged (covered with a thin coating) with concrete, or the surface may have been coated with a thicker application by hand trowel or pneumatic equipment (often termed gunite). Figure 71 depicts a parged stone abutment—all joints have been filled in with a slurry mix of concrete, and the stone faces are still showing.



Figure 71. Parged stone abutment stem.

No matter what was used originally and subsequently added, trees and brush are often growing in the crevices of the abutment foundations, whether they are built of stone or consist of cracked and deteriorated concrete. Figure 72 demonstrates damage to a stone wall caused by tree roots; as the roots enlarge, they displace the stones. If the tree with such a poor root structure falls, it will dislodge a large area of stones. If the tree dies, the mass of rotting root structure will allow the stones to become dislodged. Left unchecked, trees will completely dislodge stonework and cause foundation unit failures. It is better to cut the trees than to pull them out, to avoid possibly dislodging the stones.



Figure 72. Damage to stone wall caused by tree roots.

Another issue related to stone masonry foundations is the occasional significant loss of the finer backfill embankment material through the stone joints and crevices. Although the fine soil material will not necessarily fall out through the stonework of the abutment, it can be washed out during flooding. Large voids may result behind the stonework, increasing the risk of collapse, both in the approach roadway and/or the abutment itself.

Foundation Challenges

An engineer preparing to rehabilitate a covered bridge, subject to the various situations and conditions introduced above, must evaluate various potential actions.

If the foundations are in suspect condition, based on the engineer's inspection, replacement may be an appropriate solution. This is a safe, albeit expensive way to address the uncertainty. Unfortunately, this action is often required after decades of neglect. However, frequently the decision to replace the stone is made without considering the ramifications of such a decision.

Concrete replacements may destroy a feature that contributes significantly to the historical and aesthetic flavor of the site. Repairing deteriorated stone foundations by relaying the stones with supplemental new stone is another acceptable action and often provides beautiful and historically interesting foundations. Either action is costly, yet good quality stone foundations can be more durable than concrete and often outlast the bridges themselves.

Therefore, one should always proceed carefully when evaluating existing foundations. Sometimes, replacement is absolutely necessary. However, as noted above in the discussion of problems and in the following paragraphs dealing with individual components, it may be acceptable to retain the existing masonry abutments, with some modifications.

Deteriorated concrete abutment caps usually can be replaced without damaging the underlying materials, whether they are stone or concrete. Admittedly, it is sometimes difficult to replace a cap in close proximity to the timber structure directly above. The superstructure might have to be jacked upward to provide room for such work.

Mortared joints or parged surfaces often trap moisture and actually cause more damage to the foundation by not allowing proper drainage of the embankment material. Therefore, exercise caution when considering automatically repointing the mortar joints or repairing the parged surfaces. It might be better to remove the parging and joint material to allow an evaluation of the underlying materials. If the joints have been mortared after original construction, or parging has been placed over the surface of the stone,

it was probably introduced because it was considered necessary. If repointing and/or parging is to be retained, consider installing new weep holes (drainage openings) to allow drainage to pass through the abutment and wing walls.

Stone masonry that contains stones that have cracked in place is not, in itself, a reason to replace the stone. A single-span, timber-covered bridge can tolerate a fair amount of differential movement at the abutments without significant distress in the superstructure. Hence, an old abutment with stones that were cracked by weathering or some differential settlement has probably settled into a stable position, unless some other problem is causing ongoing movement of the foundation.

AASHTO requires a scour inspection of all bridges on a periodic basis and after major flood events. Therefore, bridge engineers need to remain vigilant against potential scour that might undermine bridge foundations on spread footings. A recent covered bridge rehabilitation project in East Delhi, NY, (see figure 73) included retaining the stone masonry abutments from 1859, but steel sheet piling was installed around three sides of both abutments to increase protection against scour action. Retaining the stone abutments was judged to be acceptable and resulted in considerable savings, compared to the cost to completely replace the abutments. Retention was considered a strong endorsement of the capabilities of stone abutments to continue to serve for a long time to come. A new light-colored concrete cap is visible immediately beneath the timber structure. The space between the old concrete and sheets has been filled with concrete. New large stone slope protection has been added to protect the slopes from scour.

Of course, what may be considered acceptable to some, in instances such as the example cited above and shown below, may not be acceptable to others. Chapter 18 of this manual discusses the Secretary of Interior standards for historic preservation and notes the judgmental nature of those standards. The combination of concrete, old stone masonry, and new stone masonry for slope protection is obviously a compromise and was strongly influenced by cost and practical solutions.



Figure 73. Modified original stone abutment—Fitch's Bridge, East Delhi, Delaware County, NY.

Support Features

Bearing Blocks

The timbers used to frame the load-bearing longitudinal trusses should not be supported directly on the foundation, whether they are concrete or stone. Any timber in direct contact with stone or concrete and in an impenetrable environment will gradually deteriorate from the moisture that condenses on large masonry surfaces and the debris that inevitably accumulates on top of the foundations.

Accordingly, some sacrificial timbers should be installed; these occasionally can be replaced without incurring the major expense of replacing primary structural components of the trusses themselves. These

buffering timbers are identified by a variety of terms, including bearing blocks, bedding timbers, and cribbing. Bearing blocks is the preferred term, because it depicts what the timbers are expected to do—they transmit the heavy weight of the bridge to the foundation.

The number, size, material, and arrangement of the bearing blocks vary, according to the preference of the engineer and/or contractor, but should be consistent with the type of truss being supported. For example, a Town lattice truss requires a larger (i.e., longer) area than a kingpost truss, because at least two intersections of lattice and chords should be supported at the abutment. The footprint size and distribution of blocks should be selected to avoid side grain crushing in the main timbers of the truss. The height of the blocks can vary widely, depending on the need to match an existing condition, or to fit the intent of new construction. The material is either hardwood or pressure-treated softwood. Figure 74 presents an example of a bearing block installation. This modified Burr arch support is from the recent rehabilitation of the Brown's River Bridge in Westford, VT.



Figure 74. Bearing block installation—Brown's River Bridge, Westford, Vermont.

The bearing blocks should be treated with wood preservatives before installation. Attempting to treat blocks in situ will not necessarily lead to long-term success. Although not authentic, some choose to use neoprene bearings instead of timber.

Another issue related to foundation conditions and bearing blocks is the fact that the top of approach roadways tends to rise over long periods of time; this is caused by deposits of granular materials at the entrance of the bridge, along with grit from snow control measures. This may indicate an opportunity during a bridge rehabilitation to raise the bridge to meet the new approach grade, rather than dig out the approach material. This can improve the hydraulic opening beneath the span and prevent approach drainage from entering the bridge. This can be accomplished by using thicker bearing blocks. Modifying the back wall of the abutment and top of the wing walls also will be required.

Bolster Beams

Some covered bridges contain special timbers between the bearing blocks and the bottom of the main trusses. Again, there are several terms: a common one is bolster beams. These large timbers are sized to extend longitudinally beneath, and usually directly against, the main timbers for a length of many feet. They usually project past the front face of the abutment for distances up to 3 m (10 ft) or more, although they sometimes are installed only over the width of the abutment. For those that extend only above the abutment, they may more appropriately be considered part of the bearing blocks.

Bolster beams are intended to shorten the bridge's span by extending the truss support beyond the edge of the abutment. Some believe that they are very helpful and important, while others disagree. Therefore, the size and length of these members vary greatly. These members raise the roadway surface above the top of the abutment. Their use may be precluded in a rehabilitation of a covered bridge that did not

originally have them, and if the grade of the roadway will not be raised. Introducing them at a site that did not previously have them, without raising the grade of the bridge, introduces a new feature that may adversely affect the hydraulic opening beneath the bridge. An example of bolster beams beneath the Fuller Bridge in Montgomery, VT, before its recent major rehabilitation, is shown in figure 75.



Figure 75. Bolster beam—Fuller Bridge, Montgomery, VT.

Hold-Downs

Many covered bridges have been moved off their foundations by floods. Therefore, much effort has been spent in attempts to anchor these structures to their foundations. Although the details for such anchors vary greatly, they usually involve rods embedded in the abutments and bolted to the timber trusses. The efficacy of many such anchor attempts remains unproven.

A better solution is to locate the structure above the 100-year flood elevation. Admittedly, this involves raising the grade of the roadway and may require purchasing additional rights-of-way. If that is possible, the anchors may not be necessary unless some special event or unusually strong wind loading is envisioned. If the structure cannot be located above the 100-year flood elevation, then introducing a hold-down support may be prudent.

The hold-down devices should be sized with reserve to accommodate the inevitable section loss from corrosion that afflicts components on the tops or sides of foundations. The hold-downs can be anchored directly into concrete by initially placing them in cast concrete or grouting into drilled holes in existing concrete. In addition, they can be anchored in concrete that is placed in and around stone masonry (one must evaluate the potential uplift capacity of such installations). They also can be attached to drilled soil anchors. It is always wise to require a load test to verify the uplift capacity. A major weakness of many devices is the lack of restraint against side motion—vertical restraint is not necessarily enough. Figure 76 presents an example of a hold-down, although it was not complete at the time of the photograph. The galvanized rod projecting up from the concrete was completed with a heavy steel bar across the top of the bottom chord, to a mating rod on the opposite side of the chord.



Figure 76. Hold-down anchor–Paper Mill Bridge, Bennington, VT.

SECTION 3. TECHNICAL ENGINEERING ISSUES

- Chapter 8 The Engineering Challenge
- Chapter 9 Design and Analysis Specifications
- Chapter 10 Issues Related to Wood
- Chapter 11 Loads
- Chapter 12 Force and Stress Analysis Issues
- Chapter 13 Design Issues
- Chapter 14 Connections

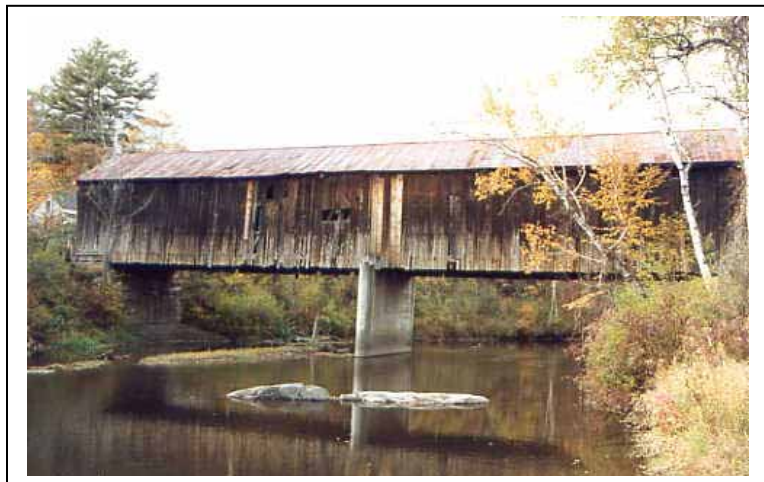

Figure 77. Thetford Center Bridge, exterior view, Thetford, VT.



Figure 78. Thetford Center Bridge, interior view, Thetford, VT.

Chapter 8. The Engineering Challenge

Overview

This section (chapters 8 through 14) is devoted to the technical issues and challenges related to engineering of covered bridges. Chapter 8 sets the stage for the technical difficulties related to this work, which are substantially complex and quite unlike work on other bridges. Chapter 9 deals with the codes and specifications that govern work on covered bridges. Chapter 10 presents the issues related to the timber itself—availability, seasoning, and sawing of members. Chapter 11 discusses the analytical evaluation of covered bridges (determining the forces in the members from various loading and combinations of loads). Issues related to the actual sizing of members to satisfy stress requirements follow. Chapter 12 deals with analysis, and chapter 13 deals with specific nuances of allowable stresses. Finally, chapter 14 presents a discussion of connections of covered bridges—one of the most complex issues confronting covered bridge engineers.

One of the most basic issues is the weight of the bridge. Timber, unlike steel or concrete, varies considerably in density and unit weight, depending on its species and moisture content. Some common covered bridge materials may weigh as little as 400 kilograms per cubic meter (kg/m^3) (25 pounds per cubic foot (pcf)) (dry spruce) or may weigh up to 640-800 kg/m^3 (40-50 pcf) (pressure treated). Such variation creates much uncertainty in predicting the actual weight of the bridge. For covered bridges, the weight of the bridge is often larger in comparison with vehicular loading than for conventional bridges, and its accurate prediction is important. In special cases, use of jacking equipment may be appropriate to allow an actual weighing of the bridge. Unnecessarily conservative estimates of weight can lead to decisions to replace members that might not need to be replaced. More specifically, while the AASHTO Standard Specifications specify use of 800 kg/m^3 (50 pcf) for timber structures, that specification is an appropriate guideline for open-decked modern timber bridges; it is not necessarily appropriate for covered bridges.

The trusses are important in determining bridge capacity (assuming the floor system is easily analyzed). The process of determining forces in the myriad truss configurations is often very challenging (see more in chapter 12, “Force Analysis Methodology”). The strength of the individual members is often very difficult to assess, and member characteristics often change from member to member in the bridge because of variation in the original construction or random member replacement during subsequent rehabilitation of the bridge. Therefore, it is difficult to accurately isolate the controlling member and its controlling stress parameter.

Determining the species of the timber and its grade is also a technical challenge. Few individuals are sufficiently skilled to identify the variety of timber components confronting covered bridge engineers. Douglas Fir and Southern Pine are common materials used in more recent rehabilitation projects, yet the original members may be of local hemlock, pine, spruce, or may even be a mixture of species. It is always safest to obtain samples and have a trained timber materials specialist identify them. Grade is a function of a number of features of the timber, including the alignment of the grain with respect to the axis of the member, the spacing of the annular rings of the wood, and defects (knots, shakes, splits). Accurately determining the grade of a timber, therefore, requires evaluation by a trained specialist. This topic is explored in more depth in a later section of this manual.

Why Do They Stand?

Given the preceding discussion of the various challenges confronting covered bridge engineers, it seems straightforward to develop a systematic method to address each of the questions or topics to identify a solution for the covered bridge in question. Unfortunately, any standard approach based on conventional bridge engineering often indicates serious distress of a covered bridge, which may not correlate with the physical behavior. Routine analysis often indicates that some bridges should have failed long ago, yet they remain standing.

This is because the bridge can withstand more load and/or stress than the analyses suggest. Alternatively, it may be that the actual safety factor is smaller than the desired one. In some instances, the bridge may not have experienced the full loading used in the design review.

The issue of bridges having more capacity than analysis suggests is not unique to covered bridges, and refinements to analysis techniques constantly are being developed to help engineers more accurately predict the true load carrying capacity of bridges.

It is important that the evaluation and ultimate rehabilitation of covered bridges be entrusted to engineers and contractors highly experienced with the nuances of covered bridges and timber structures. There is no substitute for sound judgment based on experience.

Chapter 9. Design and Analysis Specifications

This chapter covers the various codes, specifications, and guidelines that are most applicable in working with covered bridge design, and discusses the organizations that promulgate them. These specifications include one specific to bridge design, others specific to the three major structural materials, one for design loads on structures, and the primary building codes used in the United States. All viable codes are subject to regular revisions, some of them sweeping. One such major shift is the one that currently takes structural design from allowable stress methods to limit State design methods. Covered bridge designers and analysts must be familiar with all of these codes, but also may need to use methods and theories not found in any of them.

For purposes of this discussion, the various cited documents (codes, specifications, guidelines, etc.) are presented without distinction as to their technical classification or title. Each provides important reference and/or regulatory information and restrictions. To the extent relevant to work on covered bridges, they are cited in the given context; the intent is not to support one over another, except as noted otherwise. Designers must abide by the design codes mandated by each State, but most codes are sufficiently open-ended so that differing approaches can be used at the engineer's discretion.

American Association of State Highway and Transportation Officials

Covered bridge work is governed by several guidelines, most notably by those documents published by AASHTO. The organization published its first edition of the *Standard Specifications for Highway Bridges* in 1931, and has been updating this publication periodically since then.^[2] The specifications relevant to covered bridges offer guidance on loads and combinations thereof, requirements for foundations, and sections on various materials, including timber, steel, and reinforced concrete. The materials portions of the AASHTO specifications were developed to complement and to modify specifications promulgated by the organizations representing the various industries, including:

- Steel provisions by the American Institute of Steel Construction (AISC).
- Concrete provisions by the American Concrete Institute (ACI).
- Timber provisions by the National Forest Products Association (NFPA) (now the American Forest and Paper Association (AF&PA)).

Each of the material-specific sets of design guidelines, identified above, is generally aimed at the building industry. Accordingly, the specifications focus mainly on stationary structures, generally subjected to uniform loading only or so assumed, albeit sometimes with concentrated loads, and only very rarely moving loads (most frequently, crane loads in steel and concrete industrial buildings).

The AASHTO specifications, on the other hand, deal almost exclusively with highway bridges— structures that are subject to large moving loads in an open environment, exposed to harsh environmental attack. Further, bridges often represent a significant capital investment, intended and expected to serve an extended life, often targeted as 50-75 years. In practice, off-system bridges (those not on the State highway system or not under the State's jurisdiction) often receive little maintenance and may require major rehabilitation or even replacement before the end of their design lives. Major bridges and those on primary routes are often maintained with more vigilance for more years, due to the increasingly immense costs to replace them. For these and other reasons, AASHTO has intentionally adopted generally conservative provisions, usually based on the broader specialty specifications, but with its own selective modifications.

Therefore, the AASHTO specifications offer guidelines that are useful for general concepts related to covered bridges, while referring to other specifications for special needs, most notably the timber provisions of NFPA.

Initially and for many years, the AASHTO bridge specifications were intended to determine and limit stresses. This approach is called working stress, allowable stress, or service load design, depending on

the consulting agency or organization. This approach involves calculating stresses from various loads and comparing them with allowable stresses, including provisions for group load combination factors.

During the latter part of the 20th century, the bridge design industry began to address the inconsistent factors of safety inherent in the working stress method. The steel and concrete industries had begun to adopt a different approach based on strength, rather than stresses. Similarly, this alternate methodology is known by various identifiers—strength, ultimate strength, or limit states approach. This approach involves establishing factors of loading predicated on their probabilities of occurrence or confidence in predictions of various loads. The term load factor design now identifies that approach in the bridge industry.

For many years, AASHTO permitted use of either the working stress approach or the load factor approach to design and maintain both portions of the specifications. Some State agencies adopted the load factor approach, while many continued the older working stress approach.

Continued evolution of the load factor approach led to the adoption of a refinement termed load and resistance factor design (LRFD). This involves assigning capacity reduction factors based on material and member behavior, in addition to load factors based on the probability of an individual loading or loading combination. The intent of this newer design method is to allow designers to provide structures with more uniform reliability for all components. The older working stress design process often leads to nonuniform factors of safety.

AASHTO has stated that the 17th edition (2002) will be the last of the standard specifications and will receive only editorial corrections hereafter. After 2007, the LRFD specification will be the only bridge design specification that AASHTO routinely supports.

At this time, several State and most local government agencies continue to use the working stress approach for bridge design because of its familiarity and relative ease of use. More importantly, the switch to LRFD does not significantly alter the design results for the shorter, simple-span structures representing the vast majority of bridges, not only covered timber bridges.

The timber industry also has been pushing its design methods toward ultimate strength, but, as in the building industry, design work on timber-framed covered bridges continues almost invariably to use the working stress approach. In large part because analytical work on historic covered bridges involves such assumptions, using a more sophisticated design specification may seem unwarranted.

The National Design Specifications for Wood Construction

The NDS was first printed in 1944, originally published by the National Lumber Manufacturers Association.^[3] The NFPA assumed subsequent publishing responsibilities, which now have been transferred to the AF&PA. In 1992, the American National Standards Institute (ANSI) accredited AF&PA, and the NDS gained approval as an ANSI standard. It currently is identified as the ANSI/AF&PA *National Design Specifications for Wood Construction*.^[3] As noted above, the NDS is prepared for use on buildings; however, bridge structure applications are mentioned. The NDS remains the most recognized publication on timber specifications, and it is available in both allowable stress and LRFD formats.

The AASHTO specifications cite specific reference to the NDS, but some of the more common provisions found in the AASHTO specifications were lifted directly from the NDS. AASHTO includes a few special modifications, such as load duration factors for vehicular live loading.

Specifications for Minimum Loads

The reasonable design loads on covered bridges include snow loading, which is not addressed in the AASHTO specifications. In addition, the wind loading provisions contained in the AASHTO specifications are often overly simplistic and conservative for covered bridges, particularly when compared to the provisions in those specifications that are aimed more at the buildings industry. Accordingly, covered bridge engineers should seek additional guidance beyond strict adherence to the AASHTO specifications.

A popularly cited reference in establishing design loads is the *Minimum Design Loads for Buildings and Other Structures*.^[8] It is published by the American Society of Civil Engineers (ASCE), and is often referred to as ASCE 7. Like the NDS, this publication was published previously as a jointly sponsored standard between ASCE and ANSI. The previous edition is identified as the ANSI/ASCE 7^[8]. Hence, this standard is highly respected as a thorough compendium and is quite applicable to covered bridge work.

Other Building Specifications

The buildings industry is governed by a host of codes, some national (in name only, as certain regions of the country tend to adopt a single code), and others local. Those national codes more commonly cited include:

- The National Building Code (NBC), published by the Building Officials and Code Administrators (BOCA).
- The Uniform Building Code (UBC), published by the International Conference of Building Officials (ICBO).
- The Standard Building Code (SBC), published by the Southern Building Code Congress International.

An International Building Code (IBC) was published with the intention of eventually superseding the three codes noted above, because of the difficulties for designers working in various regions of the country. Also, because of differences of opinion related to fire safety and other issues in the new IBC, the National Fire Protection Association recently announced that it would develop its own complete building code as an alternative to the IBC. Thus, the likelihood of a single national code has been reduced significantly.

Many States also publish and maintain their own version of code requirements. Hence, it is very important that covered bridge engineers know the local code requirements, particularly as the requirements relate to topics with special interest to covered bridges (e.g., minimum ground snow loads).

Glued-Laminated Timber Specifications

Because rehabilitation projects of historic covered bridges occasionally involve the use of glued-laminated (glulam) components, it is appropriate to include a brief mention of this engineered wood material in this chapter. The American Institute of Timber Construction (AITC) was the standard of the industry with respect to this topic for many years; it periodically published the *Timber Construction Manual*, which contains various sections related to glulam members.^[9] The Institute also published a large, three-ring volume of material that contains useful information about this topic. The AASHTO specifications refer to AITC specifications, as do the NDS for glulam products. More recently, the American Plywood Association, in promulgating the most current specifications for the glulam industry, has replaced the AITC.

Chapter 10. Issues Related to Wood

This chapter addresses a number of issues related to wood as a material used in covered bridges. The discussion does not duplicate information readily available in common references. Instead, it attempts to clarify some topics that are of special interest to covered bridge designers and contractors.

Terminology

It is important to be definite when specifying wood to be used in covered bridges.

- “Wood” usually simply indicates material cut from trees. The word can imply reference to any size structural component.
- “Wooden” technically indicates objects or structures made of wood. Hence, covered bridges are wooden structures. Yet, in common usage, covered bridges are often also called timber or timber-framed structures.
- “Timber” is used in a number of ways when discussing covered bridges. Timber often denotes larger-sized wooden members used in structures. The NDS defines timbers as those components at least 127 mm (5 inches) thick. Timber also is used to describe standing trees before harvest. “Timber Engineering” usually refers to structural engineering that specializes in wood products; those working with buildings may refer to it as wood engineering.
- “Lumber” is used in confusing ways. Technically, lumber can indicate any size structural component, usually solid-sawn, as compared to manufactured with wooden subassemblies. Lumber commonly refers to wood products with sizes smaller than timbers. The NDS cites dimension lumber as that with thickness from 50 to 100 mm (2 to 4 inches) to differentiate it from the larger timbers.

Wood Typical to Historic Covered Bridges

A common question that often arises when discussing extant covered bridges is, “What species of wood was typically used in these bridges’ construction?” Although Douglas Fir and Southern Pine are the most popular species for more modern structural applications, most historic covered bridges were constructed with softwoods found fairly close to the bridge site. Eastern Hemlock, White Pine, and Spruce are commonly found in those bridges in the East. Douglas Fir was used in almost all western bridges. The southern covered bridges were built mostly with Southern Yellow Pine.

As important as the species is to the evaluation of covered bridges, the quality of the wood used must be put in context. Extant covered bridges, especially in the East, were often built with timbers fashioned from logs cut in the magnificent first-growth eastern forests. The timber cut in the 18th and 19th centuries differs significantly from the timber on which modern timber design codes are based. Note that while we say the timber is different, the wood itself generally has not changed much, if at all. A Colonial-era Eastern Red Spruce is genetically indistinguishable from today’s pulp logs. What have changed enormously are the forests and the trees from which those forests are made. Those first-growth, natural primeval forests were full of relatively wide-spaced, immensely tall, very thick trees. Their branches, or canopies, were far above the ground, the result of centuries of competition with their neighbors for sunlight. The competition was tough enough that the trees grew slowly, once they were of any size. The resulting wood had very tightly spaced annual rings, or tight grain. Because the canopies were so high, the logs were long, with only a few of the branches that cause knots. Much of these trees’ trunks had the opportunity to evolve from sapwood to the harder and more durable heartwood. In short, original covered bridge builders had local access to some of the best structural timber in history.

Another issue important to the wood of extant historic covered bridges is the fact that original timber often was cut from such large logs that many of the members are free-of-heart-center (FOHC), or did not need to include the heart of the tree within the sawn member. Not only are those FOHC pieces free of the tree center, or pith, which is weaker wood because it is the faster growing juvenile wood, but also they tend to

be far more stable in use. The far more common boxed heart wood, which is found in contemporary timber and is cut from smaller logs, is much more prone to distortion and splitting as it seasons. This increased movement in boxed heart timbers is caused by the differential shrinkage rates between the radial and circumferential directions.

The first-growth logs were often so straight and clear of branches that the lumber cut from them generally has far fewer imperfections, or grading defects, than found in the modern timber assumed in current design codes. The most significant lumber flaw to which these original trees were prone is the sloping grain that comes from poor sawing practices or spiral grain in the trees. This serious structural flaw can be found in the large timbers of queenpost and kingpost trusses, but only rarely in the planks used to frame Town lattice trusses. It might be assumed that those planks dried quickly enough to show their flawed grain as sloping checks in time to be replaced before truss fabrication, and that they were cheap enough that the builders were willing to replace the flawed planks and cut them up for less critical uses. In any event, the covered bridges that have survived often show signs that the builders were careful to have sorted the available stock for high-quality timbers.

Chapter 13 discusses the issues involved in establishing allowable timber member stresses when evaluating covered bridge capacities. That section includes more material about dealing with the extant old-growth timber versus modern timber components.

Wood Availability for Repairs

The availability of wood components for repair or rehabilitation is sometimes neglected in the early plan development phase of covered bridge work. The extant bridge often was built with timber components of lengths and cross sections that are larger than what is currently available. For instance, a recent reconstruction project in Upstate New York (the Hamden Covered Bridge in Delaware County, NY) involved replacing the bottom chords of a Long truss. The original Eastern Hemlock members were 230 by 330 mm (9 by 13 inches) wide by about 15.2 m (50 feet) long. They would have been cut from an impressive tree, even for the time of the construction in 1856.

A bridge in central Vermont (the Mill Bridge in Tunbridge, VT) unfortunately was destroyed by ice floes in March 1999. The original challenge was to replace it generally in-kind with local softwoods to pay homage to the original construction. However, modern design requirements and loads, coupled with current allowable stresses, meant that local hemlock was not available in the sizes and grades to satisfy the design criteria. Ultimately, the bridge was rebuilt with Douglas Fir imported from the western United States.

Part of this problem can be traced to the tendency of the NDS to list and describe timber materials and sizes that may not actually be available in various regions (e.g., Select Structural Eastern Hemlock or Dense Structural 86 Southern Pine). A designer might find timber species and grading information in the NDS and proceed with the design accordingly. Then, when challenged to help the contractor find the specified material, the engineer finds that it is not available after all, or it is cost-prohibitive.

Therefore, it is important to consider timber availability before beginning the design process. A minimum appropriate effort might be to contact potential timber providers early in the project. There are only a relative few in the United States that provide the bulk of larger (and higher allowable stress) timber components. The designer might also discuss potential project needs with contractors experienced with covered bridge work. Contact between designer and contractor requires consideration of potential conflicts during the bidding process, but the improvements in the bid documents can be significant. Hence, one might solicit advice from a contractor in another geographic area who does not intend to bid on the project in question.

Another related issue involves choosing a timber species for any replacement components. In many instances, new components are chosen based almost solely on strength properties. Fresh-sawn Southern Pine and Douglas Fir have similar strength properties, yet Douglas Fir is more available in larger sizes and lengths. Some timber craftsmen prefer Douglas Fir to Southern Pine as a more workable wood. Others, however, find that fir can be more prone to splitting than pine. Again, it is best to check early in

the process with those who specialize in this type of work (or, at least, with this type of material) to determine the preferred timber replacement material in the geographic area of the project.

Seasoned Versus Green Wood

Existing covered bridges often were built with green wood and usually have served well, despite the lack of intentionally dried wood. Those dealing with the rehabilitation of a covered bridge must decide whether to use dried or green wood. This section presents both sides of a controversial issue.

There are many important differences between seasoned (dried; moisture content below 19 percent) and green (moisture content above 19 percent) wood:

- Green wood typically is somewhat less stiff than seasoned.
- Green wood can mask inherent weaknesses in timber, such as inclined grain.
- Green wood will shrink after installation, while seasoned timber does not change size in any appreciable way (if sheltered from the direct weather).
- Green wood is slightly more susceptible to degradation from fungi and insects.
- Green wood does not retain wood preservatives and paint/stain as well as dried wood.

The *Wood Handbook: Wood as an Engineering Material*, published by the United States Forest Service, offers an excellent discussion on drying wood.^[10]

For all these reasons, it is desirable to use seasoned wood in covered bridge work, even if seasoning takes time. Thinner materials (up to 100 mm (4 inches) thick) can be kiln dried, a process that can take up to a week or more. It has been impractical to attempt kiln drying of larger timbers; hence, it is common practice to either use green material in projects (which can result in unplanned stresses during in-place drying), or to specify seasoned material.

Radio frequency, or microwave, kilns are now available for drying large timbers in relatively short times, albeit at considerable expense. Previously thought to cause little undue damage by rapid drying, there are recent reports of some problems with internal honeycombing by microwave kiln drying. These new kilns are found mostly in the Pacific Northwest. Even with careful and sophisticated restraints during drying, many timbers may require a second sawing before being suitable for fabrication. Shrinkage in the kiln, subsequent resurfacing, and some timber loss in the drying process all mean that the original timber order will need to be bolstered to compensate for these losses.

Dried timber is better to use in repairing existing structures. However, it is important to consider the cost of using dried timbers versus the consequences of using green timber. On a timber order of the size common for a major rehabilitation project of a covered bridge, the cost of kiln-dried timber will be much more than green. In some cases, it could be double the cost of that for unseasoned, fresh-sawn, timbers.

Another way to obtain large timbers that are already dry is to use recycled, or salvage, timbers. Many industrial structures were framed with heavy Douglas Fir or Southern Yellow Pine. These buildings are being dismantled to make way for other projects, mostly in urban areas. Rather than simply hauling the material to landfills, many demolition contractors are finding that it pays to dismantle the structures and sell the timbers to reprocessors. These timbers are generally high-quality and cut from first-growth logs. They also usually have bolt holes and notches that bear consideration. The industry is slowly developing standards and grading rules for using and establishing allowable stresses in these recycled timbers. The economics involved with specifying recycled timbers are unpredictable, at best. A lot of recycled timber may be available at any time, but this timber will rarely have the dimensions that the designer needs. The raw material price can also seem low, but hauling, stripping hardware, resawing, and sorting can add much to the in-place costs. The material cost of a recycled timber, in place, might be higher than for glulam timbers, for example.

To demonstrate the design penalties involved with using nondried wood, consider the NDS specifications for sawn materials (refer to the commentary in section 2.3.3 of the NDS, "Wet Service Factor"). Those

components subject to moisture contents higher than 19 percent during service are subject to capacity reductions unique to the stress type being investigated. The largest adjustment factor of 0.67 is for compression perpendicular to grain, meaning that only 67 percent of the basic value can be used. Although compression perpendicular to grain is not encountered commonly during routine design, adjustment factors of 0.80 for compression parallel to grain and 0.85 for bending are specified; those types of stresses are commonly encountered in covered bridge design.

NDS specification reduction factors for glulam components are even more restrictive. For moisture contents in excess of 16 percent during service, the allowable stress adjustment factors are 0.53 for compression perpendicular to grain, 0.73 for compression parallel to grain, and 0.80 for bending.

Covered bridges rarely contain elements subject to moisture conditions during service that approach the upper limits noted above; therefore, this issue is almost moot. However, in some rare instances, the lower elements (bottom chords and floor beams) of bridges with very low clearance above water may be exposed to higher moisture contents during service than desired. Accordingly, it is prudent in those instances to consider the moisture penalties of the NDS specifications.

While not directly related only to material issues, the use of green wood in rehabilitating a covered bridge should include provisions that require the rebuilding contractor to return to the structure to retighten all bolts and wedges, say, after 6 months shrinking and settling. The period would depend on the as-installed moisture contents. Further, the project schedule should provide adequate time for drying, should it be required.

Sawing / Sizing / Finishing

Terminology related to cross-sectional sizes of members deserves clarification. Historic covered bridges were built before industry standards that addressed sizing and finishing. Some terms commonly used include:

- Nominal size is the most common type of cross-sectional identification. Nominal sizing refers to the rough-sawn, initial cut size of the timber, before any drying or finishing.
- Dressed (or finished) timber has been further processed to plane the sides; this provides a finished, or smoother, appearance and helps “true-up” the timber to parallel sides (the initial rough saw cut may have resulted in slight thickness variations along the length of the member). This finishing typically removes up to 12 mm (0.5 inch) of thickness.
- Full-sawn timbers are actually the same size as their nominal size would suggest. Hence, full-sawn timber is cut from larger dried timber so that the full-size timber will not shrink further after drying. Full-sawn timbers are either used rough, directly off the sawmill, or are custom-sawn oversized so that they are still full size after planing. The rough, off-the-sawmill timbers are cheaper than planed nominal timbers.

Although covered bridges use heavier timbers, the lighter dimensional lumber framing industry provides insight in this regard. It is commonly recognized that a “2 by 4” (50 by 100 mm) is not actually 2 inches by 4 inches. In fact, the real size of finished 2 by 4s has changed over time. For a long time, they were typically finished at 1 5/8 by 3 5/8 inches (41 by 92 mm). More recently, the size has been reduced to 1 1/2 by 3 1/2 inches (38 by 89 mm). Hence, the 2 by 4 dimension is the nominal designation. The 1 1/2 by 3 1/2 inches dimension is the finished, or dressed, size.

Similarly, for many years the finished size of heavy timbers (up to 150 mm (6 inches) nominal) has been 12 mm (0.5 inches) smaller than nominal. For larger members, the attendant drying and planing losses have made for a 19-mm (0.75-inch) reduction from nominal to actual. The NDS supplement includes a comprehensive table of the standardized nominal sizes and their actual cross-sectional dimensions.

The sizing convention is important on covered bridge projects, because almost all the timbers used in a covered bridge project are unfinished (with the possible exception of the siding installed during subsequent rehabilitation). Further, because the focus of this manual is on historic (existing) covered bridges, the work discussed here deals with rehabilitation of existing bridges. Therefore, the designer must deal with the measured in situ sizes of existing members. Although new or added members may be different sizes than the originals, the connections and details must be compatible with existing conditions. As an example, if some chord or lattice members in a Town lattice bridge are being replaced, the new members should be the same thickness as the existing ones to minimize the problems of the physical removal and replacement, and in making connections.

A more common issue regarding timber sizing is the use of full-size members versus nominal. In many cases, using full-size members means a slight improvement in strength, which could be important. Further, many timbers for covered bridge components are resawn from larger components that have been previously harvested and air-dried in larger cants. Therefore, it is often an advantage to specify full-size members. For those larger members from fresh but resawn timbers, the cost penalty for full-size members is small or nonexistent.

Engineers should be careful when using precomputed geometric properties of wood sections (e.g., A , S_x , and I_x), because small changes in actual dimensions can lead to large changes in those values.

Nuances of Glulam Components

Glulam components are fabricated from dimensional lumber that has been dried and finished before gluing. The individual pieces are often planed again, just before fabrication, to improve the uniformity of their thickness and the glue-line quality. This means that the depths of the fabricated member are well-defined, based on the number of laminations of material used in its construction. The current standard of the industry uses 35-mm- (1.37-inch) thick laminations, and the component is made from Southern Pine (reflecting that secondary planing step), while 38-mm- (1.5-inch) thick laminations are used when the component is glued with components from western species.

The width of glulam components is based on the size of the individual pieces used in their construction. During the fabrication process, the side faces of glued components can be very uneven, due to slight unevenness in the widths and slight sweep and twist in the individual pieces used. Excess glue is also squeezed onto the side faces of the members. At the finished stage, standard practice involves planing them after gluing to preestablished widths (as specified by current standards) to remove the width unevenness from the fabrication operation and to remove excess glue.

Glulam components often are used to replace original solid-sawn members in a covered bridge. The most common application for the stronger glulam beams is for transverse floor beams. The glulam member will rarely match the existing height dimensions and may have to be cut to fit at the beam supports at the longitudinal trusses. This material shift rarely represents any significant challenge. However, if glulam components are used to replace truss elements, then the actual widths of the members may become important. Because the glulam members come in standardized and established widths, one must carefully consider the ramifications of these standard widths.

On a recent covered bridge rehabilitation project in Upstate New York (the Hamden Covered Bridge in Delaware County, NY), the bottom chords of a truss were to be replaced with glulam components. The existing truss used pairs of vertical elements with three horizontal chord elements that straddled the verticals at their connections. The existing central chord element was rough-cut and averaged 229 mm (9 inches) wide. The closest size of a standard finished glulam element was 222 mm (8.75 inches) wide. It would have been possible to replace a 229-mm- (9-inch) wide element with a 222-mm- (8.75-inch) wide member, but it was also possible to specify an industrial finish (in which the element is not planed after gluing) for the glulam member. This effectively reduced the amount of material that had to be removed in finishing the member and meant that the final width was very close to the original 229 mm (9 inches).

Wood Preservatives

The topic of wood preservatives can fill volumes. This section gives a brief description of the subject. Chapter 19 provides a much more detailed discussion of preservative treatments, fumigants, and methods for using them on historic covered bridges. It also covers both wood preservatives and the chemical treatment of wood to combat wood-destroying insects.

Another excellent summary is contained in *Timber Construction for Architects and Builders*.^[11] Since this manual focuses on aspects unique to covered bridges, the following presents only an abbreviated discussion of this topic.

As a basic introduction, wood preservatives are either oil-based or water-based. Creosote, first used in the mid-1800s, was the most commonly used wood preservative for a long time. However, the difficulties of working with creosote within today's environmental restrictions have made it less popular. Today the most popular oilborne preservative for covered bridge use is pentachlorophenol, or "penta." Some prefer waterborne preservatives; while chromated copper arsenate (CCA) is one of today's most popular waterborne preservatives, the arsenic component's effect on the environment is a concern, and its use is becoming restricted. It is unclear at this time which of the other waterborne preservatives will become the preferred replacement treatment for CCA.

Although field application of wood preservatives is possible, it is typically restricted to treating only field-cut surfaces. Applied by brush, roller, or spray, the surface treatment is relatively ineffective when compared to pressure impregnating the preservative. The typical preservative-treated timbers used for covered bridge materials are provided by specialty companies that have invested in this special equipment. The pressure treatment ideally is performed after initial cutting and drying, before delivery to the project site. This means that all end grain surfaces that are exposed during fabrication are also subject to pressure treatment.

It is easy to recommend that all wood components used in rehabilitation of covered bridges be treated with preservatives. However, there are issues involving preservatives that make their use somewhat controversial, or at least not automatic, for those involved in specifying the work.

The original structural elements of most extant historic covered bridges were built without preservative treatment. Some wood species are more resistant to rot (e.g., White Oak, locust, tamarack) and were used in critical locations such as floor elements, bearing blocks beneath the chords at the abutments, bottom chord elements adjacent to the abutments, and posts at the ends of the bridge. Modern rehabilitation projects may consider use of these species in lieu of pressure treatment.

The first widely used wood preservative, creosote, did not become available until the mid-1800s. Preservatives would have undoubtedly protected some covered bridges from early demise with rot, but using preservatives is not nearly as important in long-term performance as is maintaining effective siding and roofing materials on the bridge, and covered bridge builders understand this.

Rehabilitation projects often proceed with an initial order of material based only on an investigation that was conducted with the structure intact. After the rehabilitation is underway, it is common to find additional deterioration in elements not originally identified for replacement. Rarely do projects have enough time to order additional materials at this midpoint and wait for the pressure treatment process that is usually used for preservative treatment. In some situations, the extra time for the pressure treatment process may be unacceptable, and untreated wood is used instead.

It is best to order extra components initially, to ensure that ample materials are available when rehabilitation begins. With luck, additional material does not need to be ordered in the middle of the project. The use of preservatives is logical, in this instance. When preservative-treated timbers are used, this is especially helpful.

Another important design-related issue with wood preservatives relates to one of the most popular species in this context, Douglas Fir. The cell structure of fir is nonuniform in its composition, thereby

limiting fluid flow and making pressure treatment inconsistent. The practice of incising the wood (cutting slits into the surface) before pressure treatment greatly improves the penetration of wood preservatives in firs, but this incising structurally damages the elements; this structure is most important to thin members. The 1997 NDS introduced a reduction factor of 15 percent for bending, tension, and compression stresses for incising of dimension lumber. Dimension lumber is defined by NDS as material from 50-100 mm (2-4 inches) thick. Hence, this reduction is not relevant to heavy timber elements, but is of special interest for the components of Town lattice trusses. This is a substantial reduction and can easily lead to using Southern Pine as a substitute, because it does not need to be incised before pressure treatment.

Ideally, pressure treatment would be performed after all fabrication cuts, due to the exposure-related health concerns of cutting pressure-treated timber. However, cutting additional pressure-treated members is required in many situations. In those instances, appropriate safety precautions are required. Surface preservative treatment applications are prudent after such cuts.

There are occasional objections to the appearance of wood treated with preservatives, as compared to the extant wood without preservatives. The surface can, initially, have a greenish tint. The incising of Douglas Fir produces a texture that does not look particularly natural.

Chemically Treated Wood

Closely related to preservative treatments in wood (discussed in the previous subsection), some bridges are treated in place to deal with specific infestations of wood-destroying insects. Bridges in southern regions are prone to attack by termites or carpenter ants, and routine treatment against this assault is appropriate. Many bridges are subject to attack by powder post beetles, especially the hardwood peg or trunnel components (see figure 79), in which the surface holes are about 1.5 mm (0.06 inches) in diameter. Just as other preservative treatments against fungi (or rot) are being developed at an accelerating rate, chemical treatments for these infestations are evolving rapidly. These in-place treatments are usually applied with spray applicators.

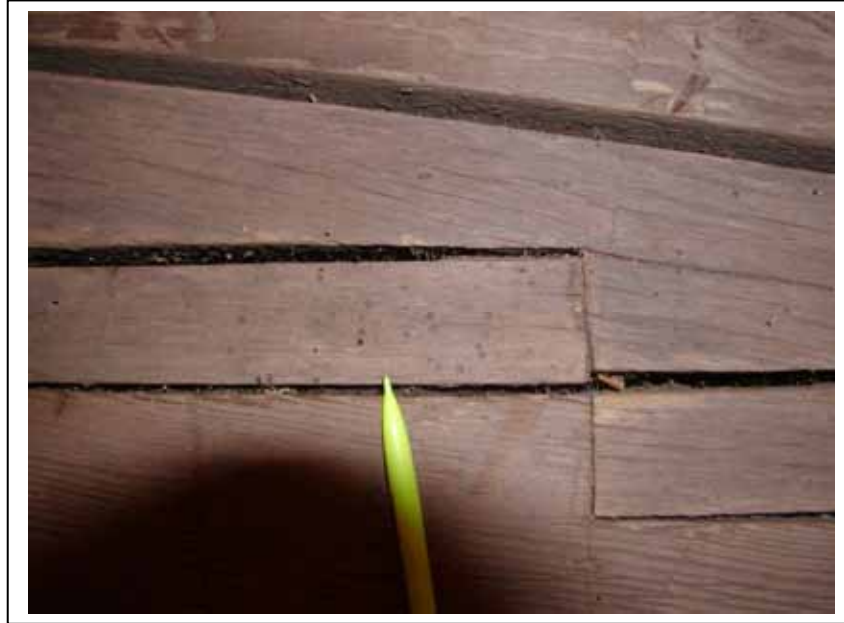

Figure 79. Surface evidence of powder post beetles.

Fire Retardants

Fire, whether by arson or from natural causes, has destroyed many heavy timber structures, and covered bridges are not exempt. Planners should make all reasonable precautions against fire loss when investing in rebuilding a covered bridge. Various chemicals have been used to treat wood products to reduce the rate of material consumption during fire or to retard the start of fire damage. The most effective applications use pressure treatment, similar to the process for impregnating wood preservatives. Unfortunately, many fire retardants introduced via pressure processes reduce the strength of the treated member. Current design specifications do not mandate specific reduction factors associated with the use of fire retardant treatments; instead, they require consultation with the manufacturer of the selected fire retardant material. Further, for extant covered bridges, the fire retardant must be applied in the field by spray or brush. At best, such surface treatments are only marginally effective.

This has been a topic of intense activity for a number of years, and an effective, field-applied treatment may be developed. When this manual was published, FHWA was conducting research to identify new generation fire retardant treatments for use on historic covered bridges.

Protective Finish Treatments

Protective finish treatments are used on the exterior siding of many covered bridges (see figure 80). Such treatments could be film forming (paint, stain, or clear coatings) or penetrating (water repellent).



Figure 80. A covered bridge with painted siding—Wehr Bridge, Lehigh County, PA.

However, many bridges do not have such finish treatments. Figure 81 shows a covered bridge with aged, untreated siding. The bridge was built in 1838 (making it one of the oldest in the United States) and has had untreated siding since its original construction.



Figure 81. Example of bridge without protective treatment (the Westford Bridge in Vermont before its recent rehabilitation).

Few, if any, historic covered bridges retain their original siding. The original siding normally would have been replaced as part of a general rehabilitation during the life of the bridge (repairing bridge trusses normally requires removing at least some, if not all, of the siding).

Specifying the subsequent siding replacement sometimes is influenced by the protective treatment used on the previous siding. If the siding was treated with a film-forming finish (paint or stain), it may be duplicated to maintain the bridge's previous appearance; if it was not treated with such a finish, the new siding also may not be treated.

Some preservationists attach little importance to the color appearance of the siding, because it is almost never original and is considered a routine maintenance feature. Others believe that color is very important for those bridges that have been painted for a long time. In that case, one may analyze the paint on the bridge to determine compositions and colors of the remaining paint; this can guide the paint selection for the rehabilitated structure.

Although an effective coating of paint or stain can prolong the life of the siding, untreated board siding usually lasts for many decades. By the time untreated siding requires replacement, the trusses often

require work as well, so a general rehabilitation contract can address the siding at that time. In other words, treating the siding has more of an aesthetic impact than any special effect on the bridge's longevity.

The decision to surface-treat the siding includes the obligation to maintain the treatment during the life of the siding. Because most covered bridges are over water, renewing the surface treatment of the siding is often a difficult and expensive operation. This may be the most practical issue related to the decision of whether to surface-treat siding, and it explains why many covered bridges are allowed to weather to natural browns and grays.

Chapter 11. Loads

Covered bridges are exposed to load issues unique to their form and material of construction. This chapter focuses on loads as they relate to evaluating and rehabilitating existing bridges, but also includes some guidance relevant to designing new covered bridges.

In simple terms, the loads are categorized as dead (nontransient, often primarily based on the bridge's self-weight) and live (transient, such as snow, and moving, such as vehicular and pedestrian). Combinations of loads involving snow are especially important to covered bridges, due to the lack of guidance in conventional bridge specifications.

Dead Load (Self-Weight)

In most short- to mid-span concrete or steel bridges, the stresses induced by the weight of the design vehicle represent a large portion of the total stress in the primary components. Stresses from the weight of these bridges, while not small, are usually much smaller than those caused by the design vehicle.

Covered timber bridges, however, are unusual in that the stresses from their own weight represent a significant part of the total stresses. The chord forces due to dead load commonly are equal to, or even exceed, those caused by vehicular loads. This is due, in part, to the weight of the roof and siding that conventional bridges do not have. The heavy timber trusses also have relatively high weight-to-strength ratios, compared with the efficient beam cross sections used in steel and concrete. This means that it is very important to predict a timber-covered bridge's self-weight as accurately as possible.

The AASHTO bridge specifications suggest using 800 kg/m^3 (50 pcf) for the density of wood when determining dead load for a timber bridge. This value is conservatively high and prudent for most common (i.e., uncovered) bridges and with most (but not all) timber species. (For comparison, many building designs use a density of 560 kg/m^3 (35 pcf) as a default density.) The 800 kg/m^3 (50 pcf) value was established when the specifications were first published in 1935. It is strongly influenced by open timber structures, which are prone to high moisture content. In addition, creosote wood preservative commonly was used, which could add as much as an additional 160 kg/m^3 (10 pcf) to the weight of the wood.

Therefore, a prudent first step in analyzing a covered bridge is to use 800 kg/m^3 (50 pcf) for the assumed weight of the wood, based on the AASHTO guidance. If the results of that assumption are acceptable, as evidenced by a calculated satisfactory live load capacity, then no further estimate regarding the weight of wood is necessary.

However, if the results of the analysis indicate an unacceptably low capacity for live load, then further investigation in determining the weight of wood may be warranted. The following discussion provides guidance on those next steps.

Wood density is strongly influenced by its moisture content, which can vary widely with environmental conditions. AASHTO's suggested density recognizes the potential for higher moisture contents (and densities) when timber components are exposed to direct wetting from rain. Covered bridge timbers, however, have lower timber moisture contents (this is the very purpose of the bridge covers) and associated reduced timber densities. The bridges inspected in the statewide Vermont study (Chapter 1) contained timbers with moisture contents much lower than 19-20 percent (a commonly cited upper limit of dry wood in the timber industry.) The aged and protected air-dried softwood timber found in most covered bridges typically has unit weights ranging from $417\text{-}609 \text{ kg/m}^3$ (26-38 pcf).

This issue is extremely important to accurately evaluate covered bridge capacities. Analyses prepared using the standard 800 kg/m^3 (50 pcf) density commonly would indicate the need to rehabilitate the bridge to replace existing elements with high strength grade timber, unusually large timber components, or even nontimber components. In some instances, to provide the necessary factor of safety, the bridge would be

unable to support any design live load. However, use of site-specific wood densities usually leads to a substantial reduction (as much as 30-40 percent) in the dead load forces and stresses.

This discussion of design wood density is intended to encourage use of site-specific unit weights for the evaluating and rehabilitating of historic covered bridges. The selection of unit weights should be based on standard timber references, such as:

- Timber Construction Manual.^[9]
- Timber Bridges—Design, Construction, Inspection, and Maintenance.^[4]
- Wood Handbook: Wood as an Engineering Material.^[10]

The selection of an appropriate unit weight for components requires that a wood scientist or other qualified evaluator examine the in situ bridge or small samples removed for such purposes to determine the species of the various elements; these also must be determined for allowable stress purposes. If some components (e.g., the floor planking) are made of dense species, then unit weights appropriate to the component should be used, resulting in an overall weight of the bridge as a summary of the individual components.

Further, the site-specific unit weight should be based on a reasonable estimate of moisture content. A moisture meter can be used to determine the actual moisture content of representative elements of the bridge. Those elements below the surface of the deck may have higher values, especially if the bridge is relatively close to water. As an alternative, actual samples of the wood from the bridge can be obtained and tested in a laboratory to determine the actual moisture content. As noted above, it is common to find moisture contents below the 19-20 percent threshold; this threshold often is cited as the difference between dry and wet wood.

The 800 kg/m³ (50 pcf) density may be used safely in lieu of site-specific densities, if that is desirable.

A related topic involves installing dry, versus green, new timber components during rehabilitation of historic bridges or for the design of new covered bridges. Conventional practice requires installing only dried primary structural components that would have unit weights as discussed above. However, the relatively nonstructural components (siding, roof boards, and some of the bracing) might reasonably be installed using green timber components. Although this could represent a heavier load than that assumed by the designer, many believe this option is acceptable, because those components will dry quite rapidly and will soon reach the reduced unit weight, in most cases before the bridge is opened to traffic. If green timber is to be used for bigger, primary components, then the conscientious designer will make appropriate modifications to the unit weight, because the larger members will take longer to dry. Another minor wood density consideration relates to the extra weight associated with most modern pressure-applied preservative treatments. Although usually quite small, common treatments could add another 16 or 32 kg/m³ (1 or 2 pcf), with the exception of creosote, which adds substantially more, as noted above.

Vehicular Loads (Live Load)

Standard Design Vehicles

When working with any traffic-carrying bridge, a primary design issue is the selection of the design vehicle. This initial subsection is not directly relevant to many covered bridges, but it is presented here as appropriate background information.

The AASHTO *Standard Specifications for Highway Bridges* identifies three types of design vehicle loads. The first two represent categories of individual vehicles and are routinely referred to as the H or HS truck. The H truck configuration includes only two theoretical axles and represents dump truck vehicles. The AASHTO specifications present information related to two sizes of H-type vehicles: the standard 20-ton (18-metric ton (MT)) (i.e., H20 (M18) truck, as in figure 82) or a smaller 15-ton (13.5-MT) vehicle (the H15 (M13.5)).

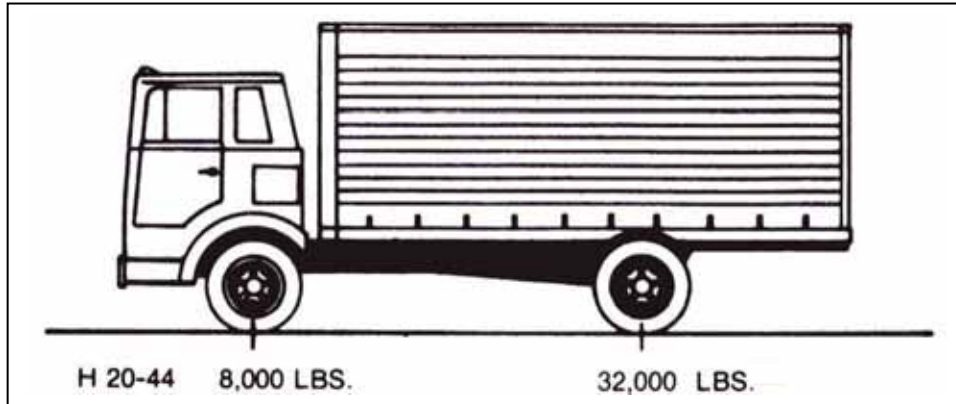

Figure 82. H20 design truck vehicle (after AASHTO standard specifications)
[8,000 lbs = 3,632 kg; 32,000 lbs = 14,528 kg].

AASHTO identifies the conventional semi- or tractor-trailer vehicle as an HS truck configuration. It is identical to the H truck, but with an extra 32,000-pound (14,528-kg) axle representing the rear axle of the trailer. The standard HS20 vehicle weighs 36 tons (32.7 MT), and the smaller HS15 weighs 27 tons (24.5 MT) (see figure 83).

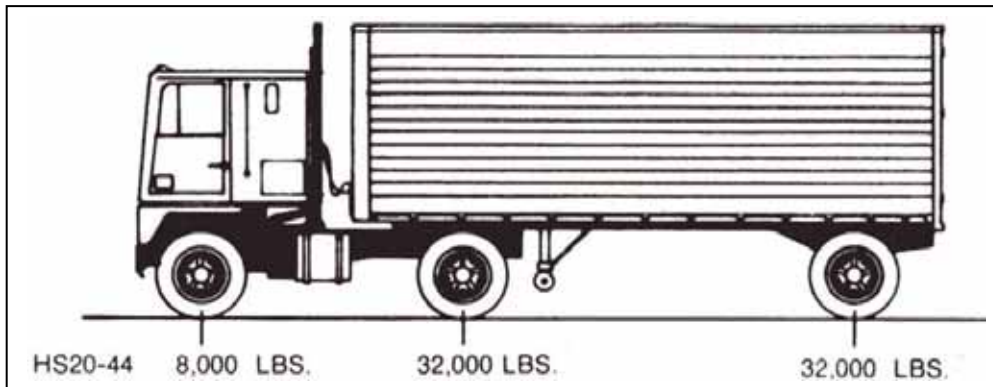

Figure 83. HS20 design truck vehicle (after AASHTO standard specifications)
[8,000 lbs = 3,632 kg; 32,000 lbs = 14,528 kg].

The third type of design-vehicular load is what AASHTO terms lane load. This uniform load scheme represents a string of closely spaced H15 single trucks (with 9.15 m (30 ft) between the rear axle of one vehicle and the front axle of the following vehicle), with a heavier H20 truck in the middle of the string. This type of vehicular load is important for long-span structures, where slow traffic can lead to a bunching effect, with heavier loads than those generated by higher speed traffic and traveling with more space between vehicles (see figure 84).

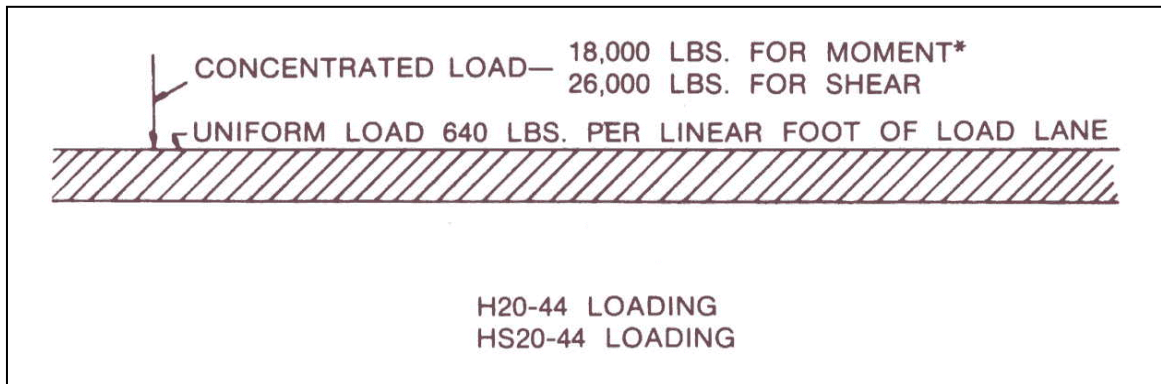

Figure 84. Lane load configuration (after AASHTO standard specifications)
 [18,000 lbs = 8,182 kg; 26,000 lbs = 11,818 kg, 640 lbs/ft = 954 kg/m].

These three vehicular load types evolved from the initial AASHTO specifications, published in 1935. While each load type is a simplified representation of the diverse vehicle configurations and weights that actually travel the roadways, this trio of AASHTO loads is acceptably accurate for the purposes of designing most bridge components. Consistent design load, unless it is completely unrealistic or radical, serves the structural design profession well.

As the trucking industry has consistently managed to obtain permission from regulatory agencies for bigger and heavier trucks, there has been commensurate pressure to increase the design vehicle used for bridge design. Several years ago, States began addressing this issue by adopting a scaled-up version of the HS20 vehicle, the HS25. Since then, this has become a common design vehicle, albeit incompatible with the typical types of vehicles traveling through a covered bridge. AASHTO also has an LRFD specification, in which an HL93 loading is used. The HL93 is an HS20 truck with the lane load added. These very heavy rigs do not travel very often on the secondary roadways where most covered bridges are located.

Design Vehicle for Covered Bridges

Bridges built in the 19th century were not designed for these modern vehicular loads. Horses and wagons crossed these bridges, along with whatever load that could be pulled through the bridge's openings. A load of loose hay was not very heavy, but skids of logs moved on icy winter roadways could be quite heavy. The commonly anticipated maximum vehicle load at the time when the original covered bridges were built would have been significantly lower than the single vehicle H15 load described above. The relatively high proportion of dead load to total load in covered bridges has worked in these bridges' favor as live loads have increased over their functional lives.

Most original covered bridges have been upgraded to safely support less weight than the standard live loads. Planning for more community vehicles is appropriate in many instances (e.g., oil trucks, loaded snowplows, school buses, and emergency equipment). Design load H15 often is selected to simulate such vehicles. When fewer heavy vehicles use the bridge, the design vehicle can be scaled back to H10 or less.

Selecting the design vehicle for use in rehabilitating an historic covered bridge is vital to minimize the effect on the required work. The design vehicle should represent the absolute lowest vehicle weight practical for the site—this cannot be overemphasized.

The selection of the live load design vehicle usually depends on the site of the covered bridge. A covered bridge that provides sole access to a dead-end road must be able to support a more diverse and complete set of vehicles than a covered bridge that travelers can bypass easily. Likewise, vehicles of any weight

will use a covered bridge immediately adjacent to a heavily traveled roadway network more than they would a bridge in a remote location.

Posted Weight Restrictions

Most covered bridges intentionally have been posted with a lower weight restriction than the bridges could (and often do) support, to limit the number of heavy vehicles using the bridge. This helps reduce bridge deterioration from overweight vehicles and extends the time between required rehabilitations. In many cases, load restrictions support community planning objectives. Regardless of the reason, select the smallest possible design vehicle to minimize the potential abuse associated with heavy vehicles, even if these heavy loads might cross the bridge safely.

Because few covered bridges can support the heaviest legal vehicles safely, a warning sign that identifies the maximum weight vehicle allowed often is posted on these bridges. FHWA suggests that the lowest weight restriction be 2.7 metric tons (MT) (3 tons). If a bridge cannot safely support this minimal live load, closing the bridge to traffic may be the best option.

There are likely to be more weight restriction violations over bridges in remote areas, so bridge designers and owners in these areas must carefully weigh whether to rely on a load posting or to close or rehabilitate the bridge.

Few means effectively prevent overweight vehicles from crossing a covered bridge. One common method is to install a horizontal bar over the roadway at the entrance of the bridge, positioned in a way to provide a restricted vertical clearance. A restricted clearance (for example, one at 2.4 m (8 ft)) prevents larger vehicles from crossing the bridge. Another method is to introduce a restricted horizontal clearance by squeezing the approach guide railing. At a minimum, this forces traffic to cross the bridge slowly and prevents some larger vehicles from crossing the bridge.

Other Live Load Issues

Some covered bridges do not support vehicular loads. In those cases, other live loads, including pedestrian load, bicycles, carriages, and lighter weight recreation vehicles, may have to be considered and investigated. AASHTO published *Guide Specifications for Design of Pedestrian Bridges* in 1997.^[12] This publication restates the provisions of the AASHTO standard specifications regarding live load allowances, although it provides a slight reduction for certain circumstances. The allowance for pedestrian loads can be quite small in most covered bridges, unless the bridge hosts large gatherings for some sort of event, in which case the weight of a large crowd can be substantial. However, because large live loads are usually vehicular, this section focuses on vehicular loads.

Impact load is another issue. A conventional bridge would be subjected to a combination of live load and an impact allowance proportioned to the live load. However, bridges built of timber do not require a consideration of impact load directly, because of wood's unique ability to absorb normal impact load without distress. This issue is discussed in more depth later in this chapter in "Load Combinations and Load Duration."

Snow Load

Most newer, conventional, deck-type bridges are not designed for the weight of snow, because standard practice involves removing snow from the bridge with plows. Typically, it is assumed that the bridge does not have to carry both heavy snow and heavy vehicles at the same time.

In contrast, covered bridges might have snow on the roof at the same time that vehicles pass through it. The bridge would therefore have to support both snow and vehicular loads. In northern States, design snow loads can become quite heavy 2.4 KPa (50 psf) or more. In some of those States, covered bridges carry snow load on the deck level; snow is deliberately plowed onto the deck to allow snowmobiles to pass. This thin layer represents a light load, which reasonable analysts might neglect. The melting snow,

however, may cause some decay in deck level timber components, so regular inspections are important. Figure 85 shows an example of the significance and consequences of snow load on covered bridges—this one collapsed from snow without vehicle load, March 8, 2001. A replica bridge has since been erected.



Figure 85. Snow load on covered bridges can cause failure—Power House Bridge, Johnson, VT.

However, because the AASHTO bridge specifications do not address this issue, it is up to the covered bridge design engineer to select a prudent snow load and live load combination. Many engineers who have experience with covered bridges believe that assuming a covered bridge must support both a full weight design vehicle and full weight snow load simultaneously is too conservative. If a covered bridge has a common 6:12 pitch or steeper roof, the vibrations from vehicles that travel across it cause heavy accumulations of snow to slide off the roof. For bridges with fairly flat roofs, however, designing for both loads could be prudent. Most building design codes differentiate between flat roof and sloped roofs (in which the latter has a slope of more than 5-30 degrees, depending on the specification) in determining design snow loads.

A bridge's tendency to shed snow load is also a function of the roofing material. A metal roof sheds snow load much more readily than does a roof with wood shingles. Bridges in heavy snow areas, therefore, may benefit from a metal roof. In addition, metal roofing systems are lighter than other types of roofing systems.

If the bridge is closed to vehicular traffic, then full snow load should be anticipated and evaluated. The snow can become quite heavy and can represent a significant load on the structure—in some cases much more than the weight of the design vehicle.

The design snow load magnitude is addressed in many specifications, but one quite commonly cited is the ANSI/ASCE 7, *Minimum Design Loads for Buildings and Other Structures*.^[8] Many State governments have special snow load maps to provide additional guidance on appropriate snow load designs; most of these target building design but are appropriate for covered bridges. As noted above, the designer of any work on a specific covered bridge should select the appropriate combination of snow load and group load factors.

Considering uniform snow load is important; however, understanding asymmetrical snow load is perhaps more important, and often controls the analysis of this type of load. Asymmetrical loading may occur from wind-drifted snow or when the snow on one side of the roof slides off before the other side. It is important to address both uniform and asymmetrical snow loads.

Wind Load

Wind load is important to covered bridge design because the wind's relatively large projected areas can develop substantial forces in the bridge. The AASHTO standard specifications do not provide sufficient guidance for developing design wind loads that address the sloped roofs found on most covered bridges.

ANSI/ASCE 7^[8] provides more specific guidance regarding wind load; it contains provisions for wind pressure coefficients against the sides and roof—both windward and leeward sides.

Wind load is important for the design of several components in covered bridges:

- Transverse and vertical knee braces.
- Upper chord level, horizontal lateral bracing.
- Lower chord level, horizontal lateral bracing (if used).



Figure 86. A covered bridge destroyed by wind—Bedell Bridge between Haverhill, NH, and Newbury, VT, 1979.

Before it was destroyed, the bridge in figure 86 had served successfully for more than 110 years. The bridge was destroyed shortly after a rehabilitation that made two significant structural modifications. First, the siding was extended closer to the eaves of the bridge, thereby increasing the area exposed to wind forces and concurrently reducing the ventilation strip that could have allowed some of the wind pressure to pass through the bridge. Second, the two-span Burr arch truss bridge was augmented with arches that had been seated in pockets cast into the abutments and pier. The rehabilitation had eliminated the pockets by filling them with concrete to reduce opportunities for rot due to trapped water. The arches were then butted against a flat surface. Eliminating the pockets removed the lateral support of the arches, thereby decreasing the bridge's ability to withstand the lateral forces from wind loads. Although the exact cause of the bridge's failure cannot be established, these two structural modifications may have contributed to its demise.

A second example of bridge failure caused by wind is shown in figure 87. Figure 88 shows alterations to the overhead bracing system in this bridge; these were made shortly before its collapse. The bracing reconnections in figure 88 were quite unusual; given these, it was likely that problems would occur.



(photograph by Jim Smedley)

Figure 87. Another example of collapse by wind—Smith Bridge at Brownsville, VT.



(photograph by Ed Barna)

Figure 88. The Smith Bridge before collapse.

These bridge failures demonstrate the importance of considering the ramifications of proposed structural modifications during rehabilitation projects.

Other Loads

Other load conditions that might reasonably be considered for covered bridges under some special situations include seismic events (earthquakes), thermal differentials, erection conditions, longitudinal and centrifugal traffic loads, and loads associated with flowing streams and ice. Of these loads, only those related to stream flow (including debris loads during floods) and/or ice forces have much relevance to most covered bridges.

In most instances, covered bridges that have survived for many decades have lasted only because they are not exposed to such water-related forces. In some cases, bridges have been able to withstand the forces related to occasional loads imposed by streams or ice floes.

As design conditions, these forces generally are not relevant to sizing members in a covered bridge. However, these rare but heavy loads do mean that consideration should be given to potential details to help strengthen a bridge in ways that counteract the rare instances of these unusual loads; these are primarily aimed at bracing or support connection details. These issues are discussed in relevant sections of this manual.

As with any structure, erection conditions for rehabilitation of covered bridges warrant careful evaluation. Timber trusses often are lifted individually to facilitate the work; in some instances, the entire bridge is lifted. Bracing the compression elements remains vital during such lifting operations. Appendix B demonstrates a truss skeleton failure due to an erection overstress during a relocation operation.

Load Combinations and Load Duration

Designing steel or concrete structures involves considering combinations of load; therefore, most structural engineers are quite familiar with assessing the probability of various load combinations. As an example, it is unlikely that any bridge will need to resist full design vehicle load, design wind load, and the structure's self-weight simultaneously. Hence, design specifications provide for a load reduction factor that depends on the load combination. The precise load combination reduction factor varies among design specifications; therefore, designers must be familiar with the specification governing the project in question. In most cases involving covered bridges, the design is based on the AASHTO specifications; hence, various combinations of dead, live, snow, and wind are usually involved. Accordingly, load combination factors from a low of 1.25 to a high of 1.4 are possible. However, combinations of wind load only rarely control primary load-bearing timber truss components in covered bridges. The controlling load combination is almost always dead load plus live load, which, according to the AASHTO specifications, has no load combination reduction factor for single-lane (or even two-lane) structures. As mentioned in the earlier discussion about snow load, AASHTO does not directly address this issue, leaving it to the designer to select an appropriate combination of dead, live, and snow loads, and a corresponding load combination factor.

To clarify, the following depicts the differences in load combinations by the two commonly cited specifications used in work on covered bridges: AASHTO's *Standard Specifications for Highway Bridges*^[2] and ANSI/ASCE 7^[8]. Those combinations relevant to the review of the covered bridge superstructure are based on service load (also known as allowable stress) design philosophy. The following load combinations were extracted from Table 3.22.1A in AASHTO's *Standard Specifications for Highway Bridges*:

- Group I - (Dead + Live) at 100% of Allowable Stress (*i.e.*, Load Combination Reduction Factor = 1.0).
- Group II - (Dead + Wind) at 125% of Allowable Stress (*i.e.*, Load Combination Reduction Factor = 1.25).
- Group III - (Dead + Live + 0.3 Wind) at 125% of Allowable Stress (*i.e.*, Load Combination Reduction Factor = 1.25).

ANSI/ASCE 7^[8] (ASCE 7-98 Section 2.4) provides the following "Combining Nominal Loads Using Allowable Stress Design":

- Combination 1 - Dead
- Combination 2a - Dead + Live
- Combination 2b - Dead + (Live + Snow)*0.75
- Combination 3a - Dead + Wind
- Combination 3b - Dead + (Wind + Live)*0.75
- Combination 3c - Dead + (Wind + Live + Snow)*0.75

Timber components can absorb loads applied over a short time without apparent distress a characteristic not true of steel or concrete. In fact, timber components can often accept twice as much load as steel or concrete, if the load is applied suddenly. This material behavior specific to timber is addressed through a load duration factor, which may range up to 2.0, as provided in the NDS. Because this load duration

concept does not apply when designing with steel or concrete, it is not familiar to most engineers and can be very difficult to understand.

A common misconception about load duration factors relates to the concurrent application of both a load combination factor and a load duration factor. Designers should understand that the duration of load factor relates to the behavior of timber as a material, while load combination factors relate to the probabilities of concurrent design loads. Nonetheless, the topic is confusing because the applicable load duration factor depends on the combination of individual loads being considered. A good discussion of this topic is presented in the *Commentary on the National Design Specifications for Wood Construction*.^[13] NDS focuses on timber and thoroughly addresses load duration, while only referencing the pertinent design specification for load combination factors (for covered bridges, this is usually provided in the AASHTO specifications).

The following example is provided to demonstrate how the controlling load combination is determined. Note that this examination is required for each component in the bridge, and different combinations of load and duration of load factor may control the design of different elements.

Consider the following two load scenarios for a timber structure:

- A. A live load (LL) of 100 PSF and a dead load (DL) of 60 PSF
- B. A live load of 20 PSF and a dead load of 80 PSF

The controlling load combination will either be LL + DL or DL alone, and it is determined by dividing the load combination by the duration factor (C_D) of the least-duration loading in each combination.

For scenario A, the two combinations are:

$$LL + DL \Rightarrow 100 \text{ PSF} + 60 \text{ PSF} = 160 \text{ PSF} \quad (1)$$

For this combination, the C_D for LL is 1.15 and for DL is 0.9. The least-duration C_D is 1.15. Therefore, the combination is divided by the C_D , which yields:

$$\begin{aligned} 160 \text{ PSF} / 1.15 &= 139 \text{ PSF} \\ DL &\Rightarrow 60 \text{ PSF} \end{aligned} \quad (2)$$

For this combination, the only C_D is that for dead load, which is 0.9. Thus, the following division is performed:

$$60 \text{ PSF} / 0.9 = 67 \text{ PSF} \quad (3)$$

One then compares the two results, and the larger quotient indicates the controlling load. In this case, the quotient for the LL + DL combination is the larger, thus the timber structure would be designed for a load combination of 160 PSF. (It is important to note that the quotient of 139 PSF is not used for design or any other purposes, only to determine the controlling load combination.) In this instance, the stresses caused by the load of 160 PSF would be compared against the basic allowable stress multiplied by the load duration factor of 1.15.

Although it may seem obvious that a structure should be designed for the higher total load combination (as it would for steel or concrete), a review of scenario B indicates how such an assumption is misleading. Performing the same computations, but with the values indicated for B, shows that, again, the two combinations are:

$$LL + DL \Rightarrow 20 \text{ PSF} + 80 \text{ PSF} = 100 \text{ PSF} \quad (4)$$

For this combination, the C_D for LL is again 1.15 and for DL is again 0.9. The least-duration C_D is 1.15. Therefore, the combination is divided by the C_D , which yields:

$$\begin{aligned} 100 \text{ PSF} / 1.15 &= 87 \text{ PSF} \\ \text{DL} &\Rightarrow 80 \text{ PSF} \end{aligned} \quad (5)$$

For this combination, the only C_D is that for dead load, which is 0.9. Thus, the following division is performed:

$$80 \text{ PSF} / 0.9 = 89 \text{ PSF} \quad (6)$$

By comparing the two results and remembering that the larger quotient indicates the controlling load, one finds that the load combination of dead load alone governs in scenario B. Accordingly, the entire design would be dictated by using a total governing load of 80 PSF (from just dead load), not the higher combined live plus dead load of 100 PSF. The stresses caused by the load of 80 PSF would be compared against the basic allowable stress multiplied by the load duration factor of 0.9.

In most cases in covered bridges, the combination of live plus dead is the controlling load combination. However, this always must be checked, and it is especially important when (1) the dead load to live load ratio is high, or (2) when any of the load duration factors are significantly above 1.0.

Because the issue of snow load in combination with vehicular load is not directly addressed in any nationally recognized design specification, the following guidance, which has been used by several engineers when confronted with this issue, may be worth considering:

Proposed load combination: Dead load plus live load (vehicular), plus snow (either uniform or drifted/unbalanced)—use a group load reduction factor of 1.33 (representing a probability of occurrence).

This is based on the ASCE 7 discussion of load combinations. This proposal is somewhat more liberal than a strict review of the AASHTO bridge specifications; these can be interpreted to proscribe only a 1.25 factor. Proposed load duration factor for this load combination comes directly from the NDS specifications:

For the combination of dead, live, and snow loads, the load duration factor would be 1.15.

The AASHTO bridge specifications use 1.15 for a two-month duration, which AASHTO also parenthetically identifies for vehicle live load. NDS has traditionally associated the two-month duration with snow load on timber structures.

However, some engineers believe this load combination and load duration factor is still overly conservative when reviewing extant covered bridges, because the results of an analytical investigation using this combination often indicate major weaknesses in structures that have successfully supported loads for a long time.

Chapter 12. Force and Stress Analysis Issues

This chapter deals with the issues related to determining member forces within the bridge and their associated stresses. The initial discussion focuses on the overall analysis of the truss, and later subsections deal with components of the floor system and bridge bracing. Chapter 13 discusses issues related to comparison of the calculated stresses with allowable stresses.

Truss Analysis—Basics

Heavy timber trusses behave much differently than more common, heavy steel trusses. Members in timber trusses are primarily subjected to axial forces, as in all truss structures, but they also are subject to substantial additional stresses from bending and shear forces. The member dead load contributes some shear and bending response, but floor beams at intermediate panel points and members continuous through connections also generate internal shear forces. A final and major contributor to these nonaxial forces is the inherent eccentricity found in many traditional timber joinery connection layouts. Unlike steel trusses, where the connections are laid out to include a theoretical intersection point for member centroids, thereby minimizing eccentricities, heavy timber truss joinery often does not provide for a common point. The original builders did this for some good reasons. Traditional joinery involves removing material from at least one member at each joint to craft a connection to another member at that joint. This represents an inevitable compromise in the member capacity. The art of designing and detailing traditional timber joinery lies in mitigating and balancing the detrimental impact of removing wood fiber from the various members involved. One classic way to balance the damage is to spread out the various members or introduce some minor eccentricities at connections between more than two members. Heavy timber truss designers distribute the damage and create a better structure, one with stronger joints between two members at a time, spread out along the length of at least one of the connected members.

To a large extent, steel trusses evolved from timber trusses specifically in ways that not only simplified the construction, but also in forms that simplified the analysis and design of heavy trusses. The connections in steel trusses, idealized with their theoretical work points (that is, where member centroids and forces are concurrent), can be analyzed for axial forces only and sized accordingly. Even rigorous computer analytical methods that include local bending caused by the member self-weight and minor inherent eccentricities—in combination with the axial forces—still usually result in stress levels that are acceptable in that same structure. The temptation to do more sophisticated modern analyses, without realizing any particular advantage, demonstrates the original advantage that steel trusses offered designers in being readily analyzed with axial forces only.

Another way to describe this is that heavy timber trusses might be more accurately modeled as frames. Frame analysis is usually performed with the help of modern software. Unfortunately, the classic hand analysis methods of moment distribution and virtual work have all but passed. Evaluating heavy timber components and structures under load combinations and variable durations can be time-consuming and tedious, even with the help of contemporary methods. Further, in many instances, the overpowering complexity of typical computer analysis output can lead to inappropriate simplification or rationalization. The thoughtful analyst may conclude that the assumptions made in the course of modeling a heavy timber frame/truss for computer analysis may introduce uncertainties well within the resolution of the professed results.

To illustrate this point, figure 89 provides an example of frame connections of a Burr arch. Note how the diagonals intercept the posts at a substantial distance down from the top chord. Although the clutter of the various elements hide it, the same geometry exists at the bottom of the posts. This is quite different from a conventional pin-connected metal truss.



Figure 89. Typical eccentric joint in a timber truss (Brown's River Bridge, Westford, VT, before its recent rehabilitation).

For these reasons, it is often a good idea for the modern analyst to return to the basics of truss analysis and investigate a timber truss structural behavior on the basis of axial forces only, assuming the truss to have theoretical and concentric work points. With the relatively simple results of this large-scale analysis, specifics of individual elements subjected to larger combinations of different forces and stresses can be superimposed for particular investigation.

As an example, a timber truss configuration patented by Colonel Stephen Long in 1830 is assembled from all timber components, with main diagonals and counters in each panel. The verticals of the Long truss are subjected to axial tension forces and substantial bending stresses, due to the eccentric loading in the diagonals relative to the location of the chord forces. The Long truss can be analyzed quite rapidly with manual methods, using the method of sections or method of joints, as long as the analyst is also prepared to temporarily neglect the action of the counters.

Certainly, there is a place for more refined analysis, but the basic analysis of a covered bridge does not have to be particularly difficult or complex.

Simplified Truss Analysis

As discussed above, heavy timber trusses can often be analyzed adequately by using a simplified model of the structure. The typical covered bridge longitudinal truss is usually built with the same depth and the same size chord elements over its span. Given this prismatic layout, determining the maximum chord force can be as simple as evaluating the mid-span moments and considering the bridge as a simple and single-span structure. With these simplifying assumptions, the maximum chord force for a statically determinate truss is simply the centerline moment in the span, divided by the vertical distance between the chord member centroids.

Another simplification that can be very useful when evaluating covered bridge trusses is that associated with using a plate girder analogy. The longitudinal trusses can be idealized as deep girders with large holes in their webs. With this simplified model, the flange forces in an idealized plate girder represent the chord forces. The section properties of the plate girder substitute are determined from the areas and vertical separations between the various elements of the chords and the parallel axis theorem. Although this plate girder simplification is just that, it nonetheless is quite adequate for at least the preliminary evaluations of a heavy timber truss.

Refined Truss Analysis

When a more exact solution seems justified in analyzing a timber truss, a computerized approach may be adopted. Most common modern software uses a finite element methodology. This software can use complex individual elements to model the various components in a timber truss. The individual elements may be the size of a single truss element or may be the size of die used in a board game. Typically, the smaller in size (and greater in number) the elements, the more accurate and precise are the analysis. While this analysis is not inherently difficult and is being offered in more user-friendly versions all the time, it nonetheless remains crucial to properly model support conditions and connection behaviors. It is the connections that can make the computer model so complex.

For example, the lattice members in a Town truss bypass each other, with two or three pegs in single shear between the layers of planks at each intersection. The accurate way to model this is to have both planks pass through a doubled node at each joint and then introduce a dummy member between the two plank nodes. This dummy member simulates the spring interconnection between the two planks. The analyst would properly try to model the peg connection with shear element and rotational springs, taking a reasonable guess at the peg pattern stiffness.

Because these sophisticated models can rapidly become overwhelming, even for today's hardware, it is still quite common to exploit structural symmetry and prepare models of only portions of the entire bridge—perhaps a half or a quarter of the structure. Then it becomes particularly important to model the support conditions properly at the artificial internal interfaces. Further, it is easy to become confused with respect to symmetrical, asymmetrical, and anti-symmetrical loading conditions.

Figures 90 and 91 portray a three-dimensional computer simulation of a Town lattice truss bridge. Figure 90 demonstrates the complete stick-model of the structure in an unloaded condition. Figure 91 depicts a similar three-dimensional image distorted from the effect of loading. At the time of this work in the mid-1990s, it was believed that this computer simulation was the most complex ever undertaken for a covered bridge.

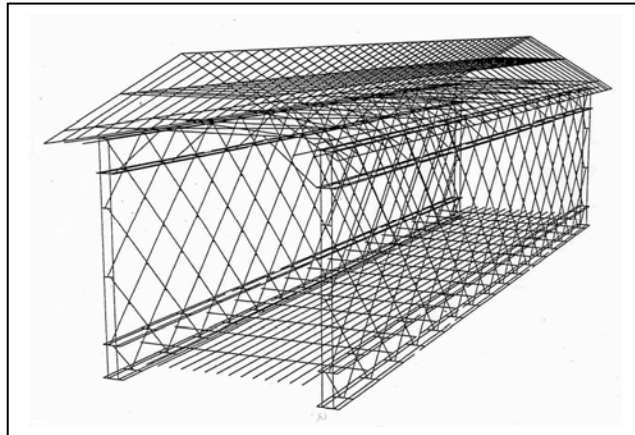

Figure 90. Three-dimensional image of computer simulation—unloaded. Note the short transverse elements at the truss lattice intersections that depict the trunnel connectors.

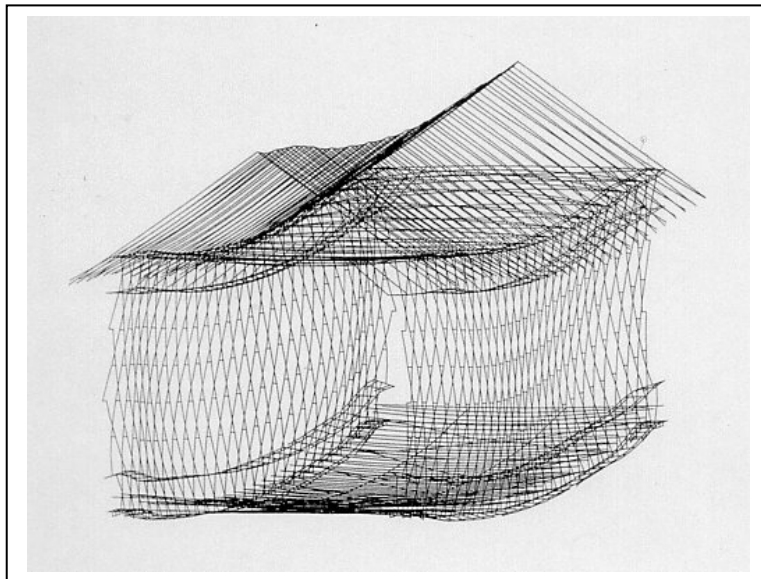

Figure 91. Three-dimensional image of computer simulation—distorted from load.

The next step in assessing the validity of any theoretical analysis involves comparing the output of the computer simulation with the measured behavior of the real structure under actual loads. One simple validation check involves comparing (1) the measured deflections in the structure at specific locations while the structure is loaded with a vehicle of known weight and configuration against (2) the computer model's predicted deflections at the same points and under the same loads. However, even if the deflections compare favorably, this does not assure that the actual forces in the structure are equal to the computer predictions for the same forces. Strain gauges have been used for a long time to measure stresses and forces in metal structures. They have also been used, albeit less frequently, when establishing structural response in concrete structures. Strain gauge measurements on full-size members in heavy timber-covered bridges are not common; however, it is possible that future work in this area will allow comparisons between computer predictions and field verification.

For many of these reasons, designers and analysts should carefully consider whether to attempt a refined analysis of the structure. It is a slow process and can be costly. However, refined computer-aided analysis can be very useful and worthwhile, in some instances, such as:

The final design of a rehabilitation project, after initial work using more basic analysis techniques.
Evaluation of elements that appear to be in serious distress and for which basic analysis techniques are unable to provide sufficient confidence.
Preparation for field load testing.

Combined Truss and Arch Analysis

The most prevalent surviving covered bridge truss type is still that supported by Burr arches, a combination summarized as a multiple kingpost truss with a superimposed arch. There are interconnections along the structure's span, between the arch on either side of the sandwiched truss, often consisting of a single bolt in double shear at each post through the arches. Hence, the two trusses and the arches share the total loading on the bridge. Common questions are: "What part of the assembly carries what share of that total load? Do they each support half of the load? If not, how much of which load type is carried in each element, and why?"

Some believe the original builders intended the truss to support all applied load, i.e., the arches provide only compression buckling resistance for the truss. Others believe that the truss was intended to support only dead loading, while the arch was there to support live loading. Either assertion can be supported.

Solving for load sharing within this structural type without a computer is tedious and not especially practical. However, using a computer program is only reasonable if performed carefully. Many Burr arch structures exhibit significant distress at the bolted interconnections between the arches and truss posts, indicating that one element or the other is not sufficiently strong to carry its intended share of the load. If the connection is distorted or failing, then the stiffness properties of the connection itself must be carefully selected and modeled for the computer analysis to have any real relevance.

To further complicate matters, the classic Burr arch involves components that bear against the bridge abutments. This introduces the issue related to the abutment stability while resisting the significant thrusts. If the abutments shift under the arches' thrust, then the thrust is relieved, and the truss member forces are redistributed. There are other modified Burr arch structures in which the arch is not supported by a thrust block at the abutment but instead terminates at the bottom chord. If the connection between arches and lower chord is adequate, the arch can be considered "tied." If the tie connection fails, however, the arch cannot offer much load support for the structure, but tends to contribute only in-plane bending stiffness and out-of-plane buckling resistance.

This combination of timber truss with connected arch components is probably one of the more difficult supporting systems confronting covered bridge engineers. Careful review, inspection, and investigation of a number of such structures indicate a lot of variability, making generalizations impractical. One very critical and difficult modeling assumption involves the stiffness of the interconnection between the arches and the truss. In any case, each of these bridges deserves careful review and evaluation. An example of a heavy timber Burr arch with its sandwiched truss is shown in figure 92. Figure 93 presents an example of a timber truss with a lightweight asymmetrical arch. It is not clear what, if any, assistance this arch provides to the truss.



Figure 92. A heavy timber Burr arch–Wehr Bridge, Lehigh County, PA.



Figure 93. A lightweight arch attached only to the inside of the truss–Salisbury Center Bridge, Herkimer County, NY.

Effect of Bolster Beams

As introduced in chapter 7 in the section, “Bolster Beams,” bolster beams are often so substantial that they can provide some support to the truss beyond the face of the abutment (see figure 94), thereby effectively shortening the theoretical span of the truss. Figure 95 provides an example of a concrete bolster.



Figure 94. Large bolster beam supported on bearing blocks—Hall Bridge, Rockingham, VT.



Figure 95. A bolster formed of concrete—Village or Great Eddy Bridge, Waitsfield, VT.

The conservative approach to this situation is to neglect the effect of the bolster and proceed with the analysis as if the bolster did not exist. In some instances, however, such an analysis may indicate the need to reinforce or replace truss elements. In that case, it may be appropriate to further consider the potential benefit of this element. Each installation of this type of element will be unique, and no general rules of thumb are available.

Floor Analysis

Analysis of floor systems is generally simpler than for truss systems, yet the results can still be frustrating, because the results often indicate that the floor components may be overstressed when they are able to withstand daily loading without apparent distress. Because covered bridges come with a number of floor system configurations, the following sections discuss individual components of the more common configurations found in most covered bridges.

Floor Beams

The transverse floor beams, spanning between the longitudinal trusses, are the principal members involved in supporting vehicle loads and transferring the live loads to those trusses. An initial dilemma in their analysis involves establishing the span length for the floor beam. For those floor beams that are supported by a truss configuration with multiple chords, one might choose the shortest distance between innermost chords and minimize the bending stresses in the floor beam, or choose the longest distance

between outermost chords and be conservative with floor beam stresses. Some analysts try to establish a reasonable bearing length at each support and use the centers of those bearing areas to set the floor beam span. While this is reasonable, it relies heavily on precisely cut bearing faces on the beams and surfaces that are perfectly level and planar on the tops of the truss bottom chords. There are always exceptions to any rule, but a good generalization is to use the distance between the centers of the trusses as the theoretical supported span length for the floor beam. Beginning with this assumption, the results can be evaluated later for their sensitivity to modest theoretical changes in the support location.

The next issue in evaluating the floor beams involves the live loading axle distribution to these beams (note that the floor dead load forces and accompanying stresses are rarely significant in traditional bridges). The AASHTO specifications offer specific guidelines for the longitudinal load distribution factor, depending on the type of deck system spanning between floor beams. Table 3.23.3.1, titled “Distribution of Wheel Loads in Transverse Beams” (AASHTO’s *Standard Specifications*), provides a range of values from $S/4$, for a common longitudinal deck plank system, to $S/5$ for a bridge with nail-laminated or glue-laminated decks, 150 mm (6 inches) or more in thickness^[2].

Because the results can be variable, this load distribution value has been the subject of intense debate among bridge engineers for a long period, and research continues on the topic. An analytical evaluation of any floor beam might imply that its capacity is a certain number of tons, although the floor beam has been supporting vehicles successfully with axle loading of substantially heavier amounts for an extended duration. The accuracy of the AASHTO load distribution factors is just one contributor to the gap between theoretical analysis and actual experience.

Covered bridge practitioners should be aware of the issue of distribution factors and are encouraged to keep apprised of any future improvements to AASHTO guidelines for axle loading to transverse floor beams.

In steel or concrete floor beams, bending stresses often control the allowable live load capacity over those limits posed by shear stresses, but shear is an important issue in any timber design and should be checked. Recall that the NDS timber specifications (as discussed in the section “Shear Force” in NDS Chapter 3) allow the analyst to neglect any concentrated loads (wheels) that are located within a beam depth of the beam support. Loads this close to the supports can be assumed to pass directly through to the rigid supports, without inducing any transverse shear stresses. Subsection 13.6.5.2, “Actual Stress,” in the AASHTO *Standard Specifications for Highway Bridges*, allows vehicle loads to be neglected if within three times the depth of the beam.^[2] This is an important distinction for those involved with covered bridges.

Builders often notched the undersides of these floor beams at the beam’s support to insert the beams or level the top surfaces of slightly varying beams to support them on slightly uneven surfaces. The shape of the top corners of some floor beams was also reduced, especially those that penetrated the web components of a Town lattice truss. The NDS specifications contain guidelines on the handling of lower face notches, as they relate to a reduction in the capacity of the members. The NDS shear stress factor functionally penalizes for the notching—removing half the beam quadruples, rather than doubles, the shear stress. This is a simple way to account for the shear stress concentrations at the corners of the notch. The NDS limits the depth of any bottom notch to a quarter of the beam depth. Shear stresses in floor beams with top corner reductions and top notches can be analyzed with the traditional use of material mechanics. The British timber code also offers some guidelines on maximum allowable top notching and recommends tapers; these topics are treated very lightly in the American timber design guidelines.

Neither the NDS specifications nor most other traditional reference books include much guidance regarding reinforcing floor beams that have been subjected to significant notching and which, therefore, exhibit the attendant high shear stresses. Some contemporary timber construction books mention vertical through bolts and side plates. Another solution is simply to use a larger floor beam. Reinforcing the notched area may be a much more economical solution. However, the proper methods and analytical issues in these reinforcement schemes at end notches are not widely publicized.^[7]

The theoretical shear capacities of transverse floor beams is regularly lower than their bending capacities, yet shear failures in floor beams are uncommon. Hence, as with the controversy involving the appropriate load distribution factor for floor beam analysis, shear capacity evaluations in heavy timber floor beams have been debated for many years. An appendix in the NDS specifications describes the two-beam theory of why timber beams that have sheared into two separate members can continue to carry significant load.^[3] The footnotes to the NDS supplement of allowable stresses mention that shear stress increases with reliably smaller checking—as much as double the tabulated values with no checking. This reflects the fact that shear stresses have been reduced more than any other stress type over the past century. This primarily reflects the impact of kiln-drying dimensional lumber. The relatively thin members, when subjected to some occasionally harsh kiln regimes, are prone to large splits or checks at the ends where the wood dries fastest. These end checks coincide with the most typical location for maximum shear stresses in simple beams with uniform loading. Simply reducing the allowable shear stresses to cover these unfortunate kiln damages did not significantly impact dimensional lumber design, but it can be significant in the heavier timber designs. It is reasonable to affirm that large, seasoned timbers with vertical heart checks, if any, can be assumed to have minimal checks at their ends. Analysts should be comfortable with taking this allowable increase in the shear stresses. However, the AASHTO and NDS specifications have not yet refined current guidelines. Research continues in this area.

Another issue that deserves special consideration in floor beams is live load deflections. The AASHTO specifications indicate deflection limitations of timber floor elements in subsection 13.4, “Deflection.”^[2] In many instances, a theoretical evaluation of live load deflection will indicate that a floor beam can have sufficient shear and bending strength to satisfy current specification requirements, but will not satisfy current deflection guidelines. Although this deflection issue has not received much attention in current literature, it is a common situation and one that warrants thoughtful consideration.

Distribution Beams

As introduced earlier in this manual in chapter 5, some timber bridge floor systems have been fitted with longitudinal members hung under, and connected to, the transverse floor beams. These members are labeled distribution beams within this manual, because they are added to help stiffen and strengthen the floor by reducing the load on any single floor beam. They do this by increasing the tendency to distribute the point load longitudinally, among more beams. The common connection between distribution and floor beams is a heavy U-bolt to clamp the distribution beam against the bottom of the floor beams, with a U-bolt at every other floor beam. Hence, as the vehicle axle traverses the bridge, it deflects a floor beam that, in turn, forces the distribution beam down, thereby pulling adjacent floor beams down in a way to spread the load over more than a single floor beam. These are, in a way, heavy suspended stringers. The distribution beams are often built from multiple parts of vertical planks. This made installation easier, while allowing the installer to stagger the individual butt joints to make the distribution beam fairly uniform along the full length of the bridge span. Figure 96 shows an example of a distribution beam system (refer back to figure 45 for another example).

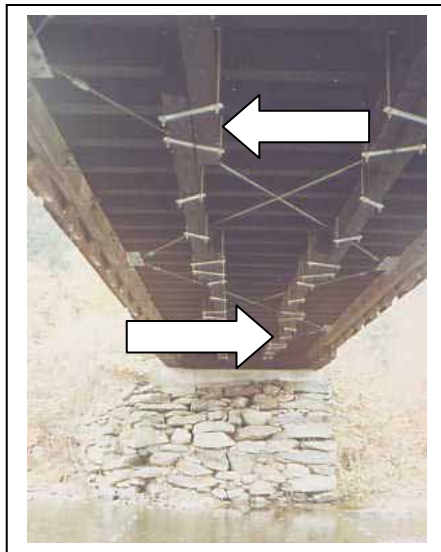

Figure 96. Distribution beam system–Worrall’s Bridge, Rockingham, VT.

A proper analytical analysis of this fairly complex floor system is challenging, and can be frustrating. One must carefully model the connection between floor beam and distribution beam to ensure a proper relationship when, in many instances, the installation has become loose due to shrinkage or wear of timber. A loose connection can significantly reduce the theoretical capacity of the intended helpmate. This grid overlay system, with its transverse loading, seems to merit computer analysis to assess load sharing between the different elements. This only makes sense when the floor system is modeled with the supporting longitudinal trusses. The heavy trusses are less than perfectly rigid under the live loading and their deflections further complicate the grid floor system behavior. This phenomenon is quite common when analysts confront their first heavy timber truss bridge. The components interact to such an extent, and in such complex ways, that the computer model can very quickly become too large and complex to analyze reasonably.

The AASHTO specifications do not address these distribution beams. An evaluation of distribution beams installed on 24 bridges was performed within the statewide study of 75 covered bridges in Vermont. That study concluded that one should neglect any potential benefit of the distribution beams, due to the commonly observed loose interconnections with the floor beams.

Although the connections are too loose for the distribution beams to offer demonstrable benefit to the bridge, these connections are still capable of holding up the distribution beams and thereby impose a dead load penalty on the floor beam capacity. The potential benefit of suspended dead load helping to damp vibrations in the floor system is esoteric enough to defy much further analysis. Accordingly, the Vermont report finally recommended removing the distribution beams during the bridge’s next rehabilitation. Further, the connection detail modifications were not trustworthy enough to recommend their retention. Finally, because most of these members were added during the mid-20th century, they have no significant historic importance, so their removal should not concern historic preservationists.

Based on this discussion, distribution beams are not recommended for new covered bridges or in rehabilitation of extant covered bridges. Further, they should be removed from bridges during subsequent rehabilitation projects.

Stringers

Analysis is relatively routine for floor deck systems that include a layer of longitudinal stringers. The support length typically is taken as the center-to-center distance between the supporting transverse floor beams. Guidance for the live load distributed to an individual stringer is provided by AASHTO in Table

3.23.1, “Distribution of Wheel Loads in Longitudinal Beams,” of the *Standard Specifications*.^[2] This load distribution factor is a function of the thickness and composition of the decking material spanning between the stringers. While there is evidence that the AASHTO distribution factors for such stringers are also conservative, the stringers in authentic covered bridges often have more theoretical capacity than do the supporting floor beams.

Although bending stresses traditionally control the capacity of stringers, shear stresses should be checked as well. As with the transverse floor beam, the NDS specifications allow the analysis for shear to neglect any live loading within the theoretical depth of the stringer from the support, while the AASHTO specifications allow neglect of vehicle loads within three times the depth of the stringer.

Decking

The very wide range of timber decking configurations found in covered bridges makes it difficult to generalize about this topic, although a few decking types are common enough to mention specifically. Longitudinal decking that spans between transverse floor beams may be flat and very heavy plank construction, nail-laminated planks on edge, or glulam panels. The AASHTO specifications provide guidance about these load distribution and support spans in these decking types in subsection 3.25, “Distribution of Wheel Loads on Timber Flooring.”^[2] Issues related to both bending and shear stresses are similar to those covered in the discussion above for stringers and floor beams.

One further complication when evaluating timber decking is the fairly common sacrificial running planks on top of the main decking. Although the AASHTO specifications do not offer any guidance regarding the effects of these planks, it is recommended that the structural contributions of these generally light planks be neglected in analyzing the floor system.

Bracing Analysis

Bracing analysis is not covered much in texts. Most bracing is installed in covered bridges to help keep the structure aligned and to counteract forces that might realign the members. The major force driving the bridge away from straight and plumb is lateral wind loading.

Many classic and basic structural engineering texts discuss force analysis in the wind bracing systems used in steel through trusses.^[14,15] For the basic single-span structure, horizontal wind loading is divided evenly between the load against the top chord and the load against the bottom chord. The wind loads applied at the bottom chord level are transferred directly and longitudinally to the abutments, through a bottom lateral system (or the deck itself, as a diaphragm). Most floor decks can provide ample lateral load strength without an additional bracing system, provided that there are good connections to the truss. The wind load that is applied to the top chord level, however, must also travel back and down to the abutments through some means, which often are not very strong and stiff.

There are two ways that the upper level applied wind loads are transferred out and down to the abutments. The difference is mainly in whether the lateral loads are transferred down to the deck level and then out to the abutments, or whether they are transferred at the upper level and then down all at once, at either the abutments or portal. The first analysis option is to evaluate the wind loading at the top chord level that is collecting to the ends of the span and then being transferred down to the abutments through very heavy portal framing. The lateral load accumulates along the span, heavily loading the end panels of the overhead X system. Many existing upper level bracing systems can carry the loads to the bridge ends, but only a very rare portal is sufficiently well-detailed and strengthened to handle this concentrated vertical load transfer. For this load-carrying mechanism to work as intended, the end sway frame system must be particularly well-connected and detailed. Depending on the connection details used for this type of system, the bracing forces may be considered to be tension-compression or compression-only, further complicating the design of this very heavy portal framing scheme.

The other analysis option is to evaluate the wind loading applied at the top chord level as being transferred immediately down to the deck level at each intermediate sway frame or truss vertical at panel points. This avoids building up a large and concentrated lateral force at the bridge ends. This scenario

generates less force at any given sway frame, one that demands less of each, yet the same issues prevail regarding tension-compression or compression-only joint details in the braces.

Given these two profoundly different lateral load flow schemes, bracing sizes, connections, spacing, and details vary widely among historic covered bridges. In most instances, the bracing of an extant bridge can be justified analytically, and thereby improvements may not be necessary. Yet at other times, improvements may be indicated as being entirely necessary due to inadequate sizes and/or details.

Figure 97 provides an example of an extremely weak upper bracing system. In fact, there is no X lateral system and no knee braces, and the tie beams are skimpy. Figure 98 shows an example of an extremely strong upper bracing system. In addition to heavy tie beams, there is an X lateral system and strong knee brace frames connected to a heavy collar tie near the peak of the roof.



Figure 97. No X lateral system and no knee braces—Comstock Bridge, East Hampton, CT.



Figure 98. An extremely strong upper lateral and knee brace system—Hamden Bridge, Delaware County, NY.

Chapter 13. Design Issues

Engineers working on historic covered bridges must face many issues when assessing the capacity and condition of existing wood members. This chapter addresses some of the technical design issues related to calculating capacities of existing members and structures, as well as those for new component replacement members.

Material Properties/Allowable Stresses

Determining the appropriate material properties and allowable stresses to use in evaluating an extant covered bridge is challenging. The current NDS specifications contain allowable stresses that are based on extensive information and experience with timber, yet there are still concerns that the NDS values are quite conservative when applied to the timber found in historic covered bridges.

The first step in determining member capacities involves identifying the wood species. As mentioned in “Wood Typical to Historic Covered Bridges” in chapter 10, several species of wood may exist within an extant covered bridge, so it is important to determine the wood species for the particular structural members under consideration. It is appropriate and relatively inexpensive to obtain small samples of the members and have them identified by a wood scientist (for clarification, see “Wood Species Identification in chapter 15).

The next step in assessing a member’s capacity involves determining the grade that most accurately describes the members. This identification is more problematic than identifying the species. Again, it is appropriate to seek assistance from an expert. There are several popular timber grading associations, many of which offer services involving onsite and in situ timber grading. The cost for this service is relatively nominal, compared to the entire analysis cost, and is an important aspect of evaluating the bridge. However, the grader can only provide visual grading for the material that is visible. In addition, the grader cannot definitively identify the grade of a structural component if portions of the member are hidden from view. The grader can determine, however, what the member is *not*, based on the member faces that are visible (e.g., the member does not meet the criteria of a select structural member, or does not meet the requirements for a number 1 grade).

Therefore, engineers still must exercise some judgment. For example, if a given member does not meet a select structural grade, it probably is safe to consider it as meeting the next lower grade. It is important to understand that grading rules are a function of the species and grading association that promulgates the rules covering those species. What is a select structural in one species and its associated rules may not be the same in another species. Further, some species and grading associations do not have provisions for all grades for all species and in all timber size categories.

After identifying the species of the member(s) in question and their corresponding grading, the next step involves selecting an appropriate allowable stress. Begin with the NDS; however, the NDS allowable stresses are based on extensive tests of newer wood samples and use a fairly complex mathematical process to extrapolate raw laboratory tests of small clear specimens to allowable stresses in full-size members. One of the major components in deriving allowable stresses from laboratory tests is based on a probabilistic approach using a 95 percent exclusion rule. In simple terms, the allowable stress is based on a failure strength that 95 members out of 100 will exceed. In other words, statistically only 5 members out of 100 will possess a failure stress less than that used for determining the tabulated allowable stress. This particular aspect of timber design has no counterpart in other common structural materials, such as steel or concrete, because of the variability of wood both among species and within the same species.

Some designers reasonably argue that, although this approach helps design new timber structures, it may be too conservative for evaluating an historic timber structure such as a covered bridge. Bridge components that have served successfully for at least 50 years (and maybe much longer) have been tested by time. Those components that contained the weaknesses implied by a 95 percent exclusion rule have either already failed or have not (yet) been highly stressed. Therefore, it may be appropriate to consider some other exclusion limitation—some have suggested 80 percent. However, the current

specifications do not address this issue, and it has not attracted much attention because it affects very few structures.

For more information on this topic, refer to guidance provided within the American Society for Testing and Materials (ASTM) Specifications:

- ASTM D 143 “Methods of Testing Small Clear Specimens of Timber.”
- ASTM D 198 “Methods of Static Tests of Timbers in Structural Sizes.”
- ASTM D 245 “Standard Practice for Establishing Structural Grades and Related Allowable Properties for Visually Graded Lumber.”
- ASTM D 1990 “Standard Practice for Establishing Allowable Properties for Visually Graded Dimension Lumber from In-Grade Tests of Full-Size Specimens.”
- ASTM D 2555 “Standard Test Methods for Establishing Clear Wood Strength Values.”
- ASTM D 2915 “Standard Practice for Evaluating Allowable Properties for Grades of Structural Lumber.”

At this writing, research continues to examine the issue of what allowable stresses to use in existing timber. However, the authors of this report have not identified any definitive published work to assist users of this manual in relation to this issue. This discussion is intended to encourage reflection regarding assumptions about evaluating historic covered bridges. Until other information is available, the allowable stresses published by NDS should be used as the basis for the analytical evaluation of historic covered bridge capacities.

Figure 99 presents an interesting materials issue. The original truss diagonals in this figure were made from American Chestnut. Modern specifications do not provide allowable stresses for this species, because it is so rare. Therefore, the allowable stresses must be determined using ASTM procedures.



Figure 99. American Chestnut (allowable stresses are not in the NDS)—Comstock Bridge, East Hampton, CT.

NDS Penalty for Tension Stresses in Large Members

Although this topic has been in the literature for awhile, it has not received much notice, and it has significant applications in timber-covered bridge capacities. The following is a brief synopsis of the issues involved in this very complex topic.

Until the 1960s, common practice was to establish the allowable tensile stress in wood members as a theoretical extrapolation of its measured failure stress in the tension zone of bending specimens. In part, this was due to the difficulties of developing tensile load testing equipment that could test timber specimens to failure without simply breaking at the grips. The grip zone failure casts legitimate doubts on the tensile stresses in the member at failure. Eventually, new grips were developed that led to satisfactory results in axial tension to failure tests. Unfortunately, the newer tests demonstrated that wood has less tensile strength than previously predicted by the flexural tests.

For smaller specimens, the differences between axially-induced and bending-induced tensile stresses were not major. However, as specimen size increased, the differences became significant. The 1977 NDS specifications introduced a new reduction factor of as much as 40 percent for allowable tensile stresses for members 254 mm (10 inches) and wider, and number 1 grade or less. This new reduction had a major effect on the allowable capacity calculations for timber trusses with larger chord and web members.

Many buildings offer practical examples that illustrate the rationale behind this change in the specifications. Many World War II vintage timber warehouses were built with heavy timber trusses and have demonstrated significant and frequent tensile fractures in the bottom (tension) chords. Figure 100 depicts one such example, albeit in a timber that had substandard slope of grain and a knot defect at a critical joint area. Figure 101 shows a classic example of a tensile failure in the bottom chord of a covered bridge.

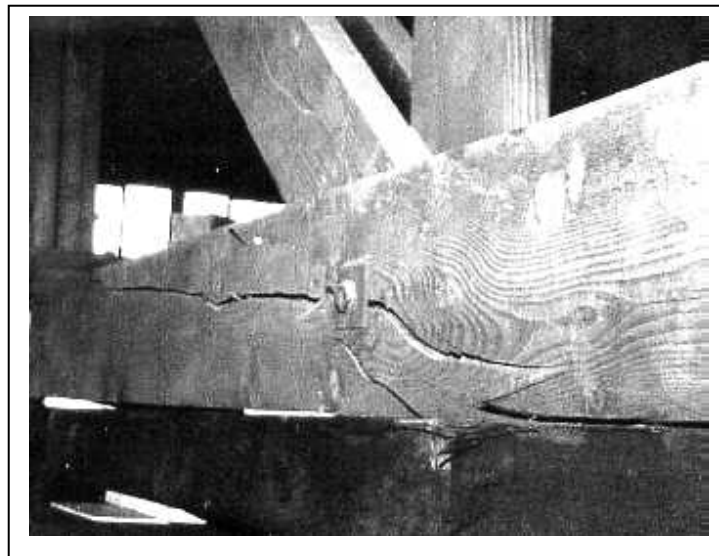

Figure 100. Example of tensile failure of a bottom chord element in a World War II timber building.



Figure 101. Example of a tensile failure of a bottom chord in a covered bridge.

Because evaluating timber-covered bridge load capacities can lead to considering changes in specifications and the effects of such changes, it is good to keep this issue in mind. It also reinforces the importance of paying particular attention to the tensile members in covered bridge trusses.

Horizontal (or Along-the-Grain) Shear

General

The historical development of allowable shear stresses in timber elements includes much controversy. This manual does not contain a lengthy discussion of this topic, but the relevance of horizontal shear is particularly important in evaluating existing floor beams and/or designing replacement components.

In short, the predicted shear capacity of a floor beam often is substantially less than loads routinely crossing it. For many years, the NDS specifications have allowed an increase in the basic horizontal shear allowable stresses for those members with limited or no-end checks or splits (double if no defects). The allowable shear stresses have decreased significantly, primarily because of the growth of kiln-dried lumber. Kiln drying tends to induce checking at the ends of the pieces. Because this coincides with the location of maximum shear stresses in most simple-span applications, the code-promulgating bodies have been decreasing this allowable stress conservatively. It has not made much difference in typical lumber scale structures, where shear stresses are not commonly the limiting condition. However, it has had quite an impact on heavy timbers; this led to the NDS provision permitting increased allowable shear stresses with minimum checking at ends. There is no guarantee that checking will not occur with new lumber, but it is relatively easy to establish in existing beams. Even with this increase, shear still often controls the capacity of the floor beam.

Those involved in covered bridges are still trying to determine why floor beams appear to have more available strength than current specifications recognize. Unfortunately, there is no consensus concerning how to change the current specifications to increase shear allowable stresses.

An example of horizontal shear failure (albeit in a vertical plane in this post) is shown in figure 102, above the diagonal notched into the post. Note that the right side is offset upward (with respect to the left side) above the diagonal.

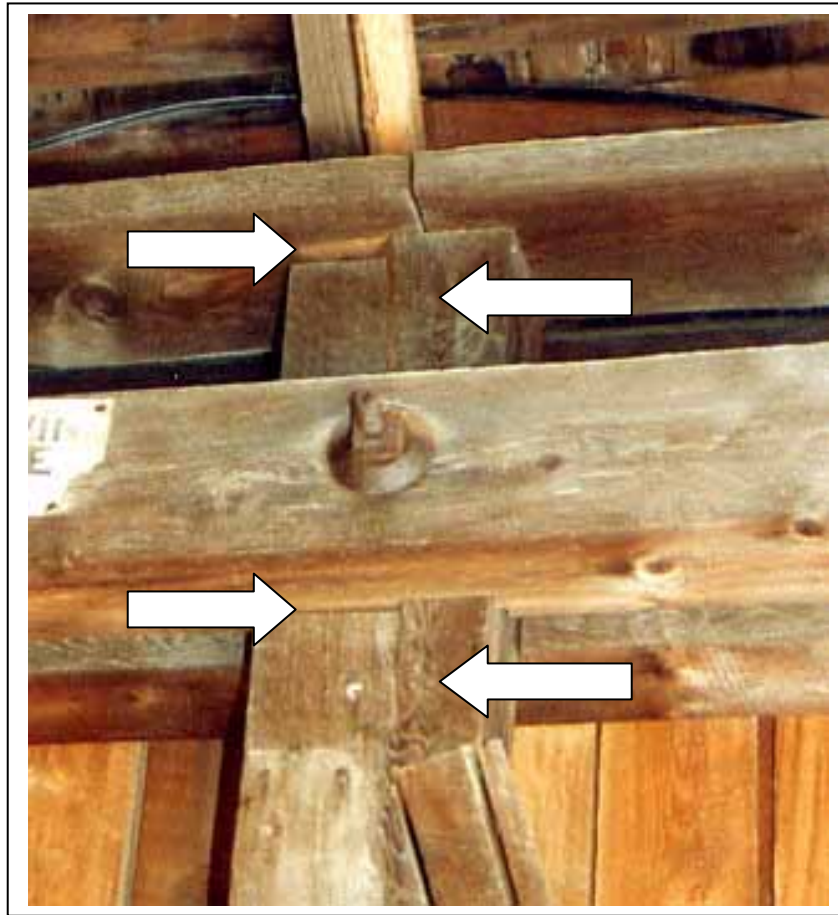

Figure 102. A horizontal shear failure—Mill Bridge, Tunbridge, VT, before its recent collapse due to ice floe impact.

Nuances of Loading Location As It Relates to Horizontal Shear Stresses

Horizontal shear stress is most likely to become an engineering issue when designing or analyzing the floor members in timber bridges. One of the quirkiest aspects of calculating shear stresses in floor members relates to the AASHTO provisions about load position with respect to the support. The commonly accepted methodology is that point loads are included in calculating actual shear stress only if these loads are located farther from the theoretical center of the beam support than the beam depth. However, live loads (in this case, vehicular wheel loads) are included only if they are no closer than “3 times d ” (d being the depth of the beam) away from the support (see AASHTO specifications, section 13.6.5, “Shear Parallel to Grain”).^[2] For a typical bridge floor beam (250 mm (12 inches) deep), in which the span may be 4.6 to 5.5 m (15 to 18 ft), these provisions can substantially change the design stress calculation, due to the relatively small aspect ratio of beam span-to-depth.

Because the dead load of the floor system is usually insignificant compared to the effect of vehicular loading, it is reasonable to neglect dead loading. This means that the analyst would evaluate the shear stresses with the load placed at $3d$ from the center of floor beam support. A conservative analysis that checks the stress with the load located only a single beam depth away may indicate that a given floor beam is overstressed in shear, while a more refined analysis might well demonstrate that the beam is acceptable.

Because of the apparent increasingly conservative assessment of shear capacity built into the current allowable shear stresses, one should be wary of being additionally conservative with the loading conditions. Therefore, using the current specifications, vehicular live loading shear conditions should be checked at $3d$ away from the support.

Chapter 14. Connections

Introduction

This chapter does not attempt to duplicate the basic connection information available in typical timber references. As examples, lag bolts, through-bolts, and simple bearing connections can be addressed with the NDS. Rather, this chapter presents connection issues that are unusual (and not covered in the current literature) or are of special interest to engineers working with covered bridges.

Truss Connections—Trusses Other Than Town Lattice

The so-called traditional timber connections used in building the historic covered bridges usually rely on traditional timber joinery—notches, wedges, bearing faces, mortises, keys, tenons, and pegs—rather than on the more common groups of steel mechanical fasteners in single or double shear, as used in more recent times. Many of these connections can be analyzed, and their capacities determined, with only some basic assumptions and allowable stresses. Allowable bearing stresses, both parallel and perpendicular to the grain, and shear and tension stresses are all that are required to assess many traditional connection capacities. Some contemporary repair methods used with historic timber bridges have relied on bolted connections. Typical wood engineering references and current timber design codes provide ample discussion of these bolted connections.

One reason that the original covered bridge builders used very few steel bolts was these bolts' relatively high cost, at the time. Many covered bridges were patented and built before heavy bolts were mass produced. In addition, heavy bolts in large patterns are not easy to install properly. Most heavy traditional timber truss members were coplanar (i.e., all sharing the same plane), further reducing the efficiency of bolts, which are best loaded in shear. Finally, heavy steel connectors condense moisture deep within even those timbers that are protected from direct weathering, fostering decay in critical zones that are hard to see without dismantling at least the joint. However, many traditional covered bridge connections did include one or two bolts. In most cases, the bolts held or clamped the timber structural components together. Although some shear or axial forces might be transferred through these clamping bolts, that capacity is rarely of any consequence when compared with the capacity of the timber joinery, and therefore usually is neglected in assessing the joint capacity.

Tensile Member Connections

Most timber designers do not like to discuss moment connections between two discreet heavy timbers because this load transfer is simply too hard to achieve. Therefore, coaxial tension connections (i.e., those involving members along the same axis and connected together to resist tension forces) are the most challenging joints, no matter which connection method is used.

The innate limitations imposed by traditional joinery methods are most pressing to the designers and crafters working with coaxial tension joinery. The traditional tension connections between coaxial truss components are handled with a variety of joints. These include lap joints, scarf joints, bolt-of-lightning joints, fish-plated connections, keyed joints, rod-and-tenon joints, and multiple tension chord members with staggered butt splices—reducing the impact of any single splice on the truss capacity. Some builders even used extraordinarily long members that precluded the need for tension splices. The following subsections address each type of tensile joint.

Lap joints describe a complex family of connections that extend the apparent length of the connected timbers, within the available and original cross section. The simplest lap joint overlaps halved members, with transverse (or through-plane) connectors transferring the tension force in one member to the next, through single shear forces in those connectors. Those through connectors can be steel bolts or wooden dowels. The available strength of these simple lap joints is immutably limited to less than half the gross tension capacity of the members. The net section of the lapped portion is only half of the gross. The through connectors remove further material, reducing the available tension capacity to less than half the gross (see figure 103). Transverse connectors, loaded in single shear, are not as stiff as those loaded in

double shear. This means the spliced section of the tension member will not attract or resist the same tension forces that it would if it were an uninterrupted timber.

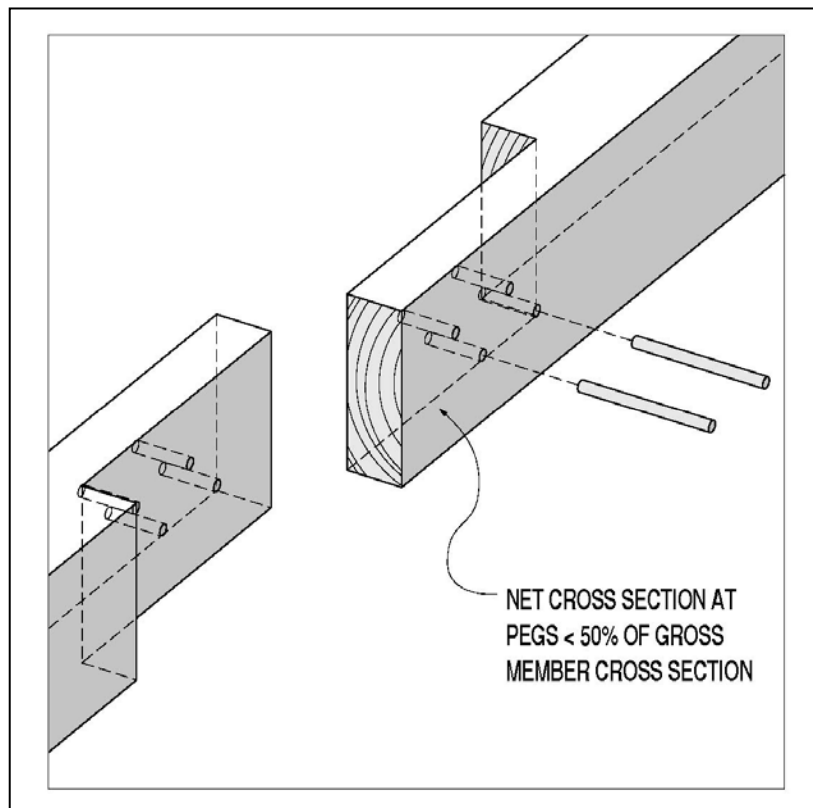

Figure 103. Simple lap joint, with through-plane connectors

A remarkable lap joint can be found in the lower chords of the Taftsville, VT, covered bridge. Those hand-hewn 350- by 450-mm (14- by 18-inch) members overlap for a full 7.3 m (24 ft). The tension forces are transferred between those two members and across the lap length through shear keys and bolts.

In other lap joints, connectors are lying in the shear plane; in these joints, wooden keys or dowels are the most common in-plane connector form (see figure 104). Again, the net cross section is further reduced from the half that is the lapped timber. The dowels and most shear keys are oriented with their grain lying in the same shear plane, but perpendicular to the longitudinal axes of the spliced members. This grain orientation is a compromise made for the convenience of the builders in the face of available wood component sizes. The dowels or keys are oriented so they are being crushed in side grain, as opposed to end grain, bearing. This is a weaker loading direction, by a factor of about double. Furthermore, the dowels or keys are being sheared in a way that results in their fibers or cells being rolled by one another instead of along each other. This rolling shear stress capacity is about half of that found in along-the-grain shear stress. Figure 105 shows side grain bearing and rolling shear stresses.

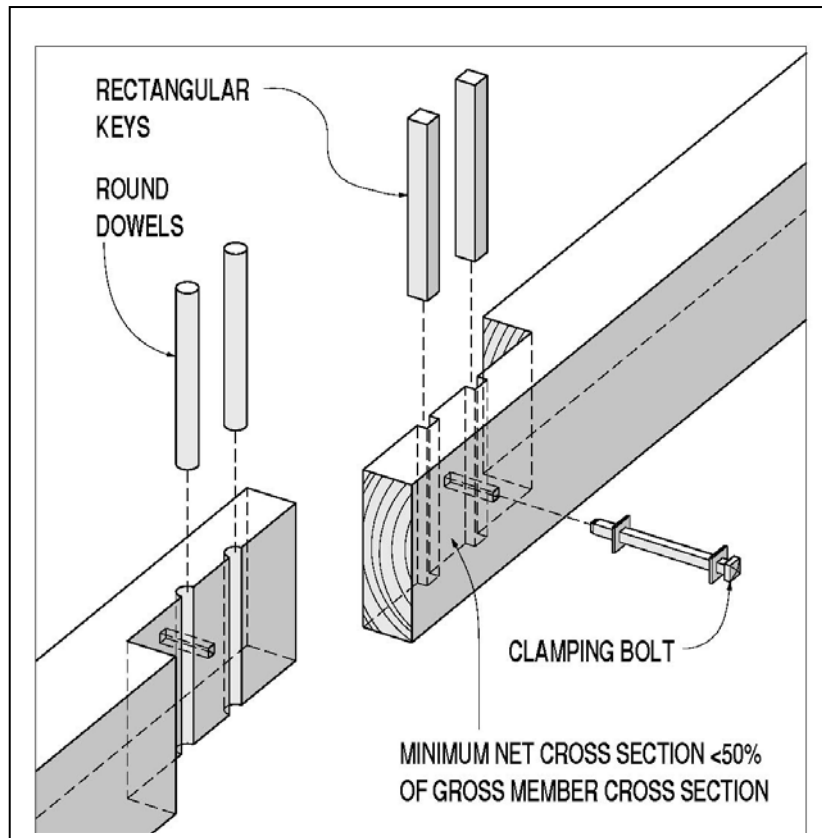

Figure 104. Simple lap joint, with in-plane connectors.

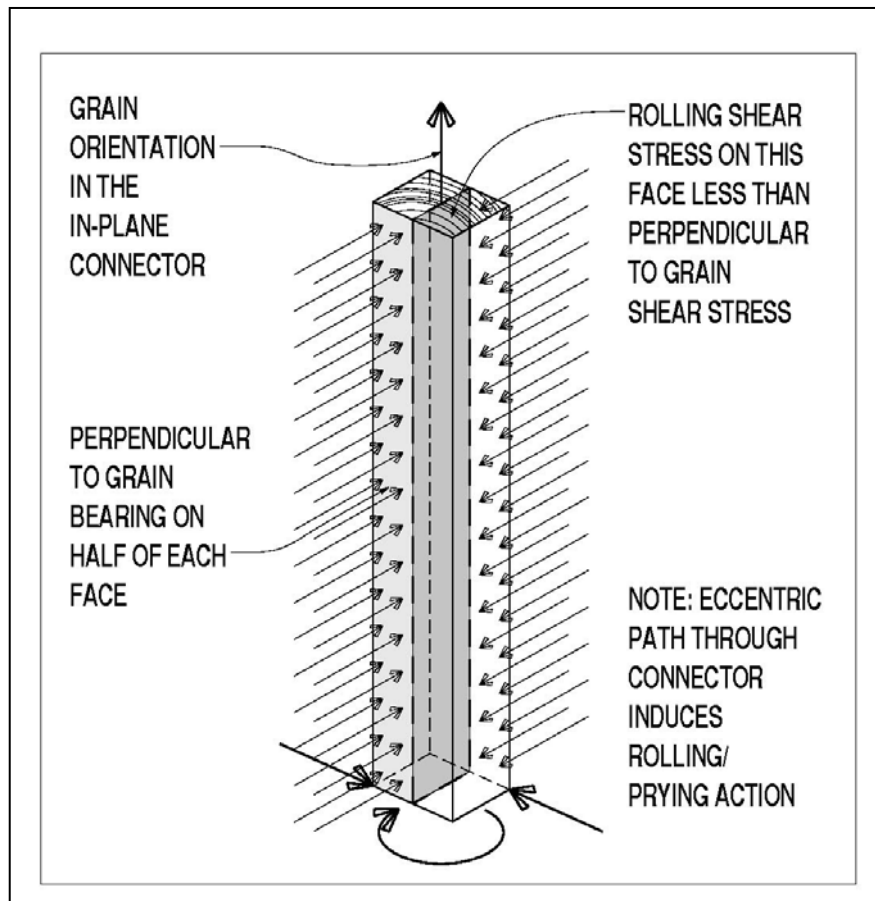

Figure 105. Grain orientation of rectangular in-plane connector.

Some lap joints avoid using either through-plane or in-plane connectors by removing enough of both members to leave room for a direct end grain bearing surface between them. The allowable end grain bearing stress is higher than the side grain bearing on the dowels or keys. Because of the deeper notching involved, the theoretical capacity is still less than 50 percent of the gross, but the simpler and stiffer end grain bearing offers significant upgrades in overall performance. The craftsmanship required to generate uniform and even bearing surfaces can be daunting, however, when compared with the skill involved in installing through-plane connectors. Some builders overcome this fitting challenge by putting tapered shear keys (or wedges) at this bearing seat. While achieving uniform bearing more reliably, this advancement also introduces side grain bearing faces, with their reduced capacity and stiffness. There still is a shear stress consideration in these bearing lap splices—the shear capacity of the section between the bearing face and the end of the spliced member. This shearing along the key line is actually the most common failure mode for these splice joints. Figure 106 shows an example of a lap joint with bypassing leaves and end grain bearing surfaces, also with tapered wedge.

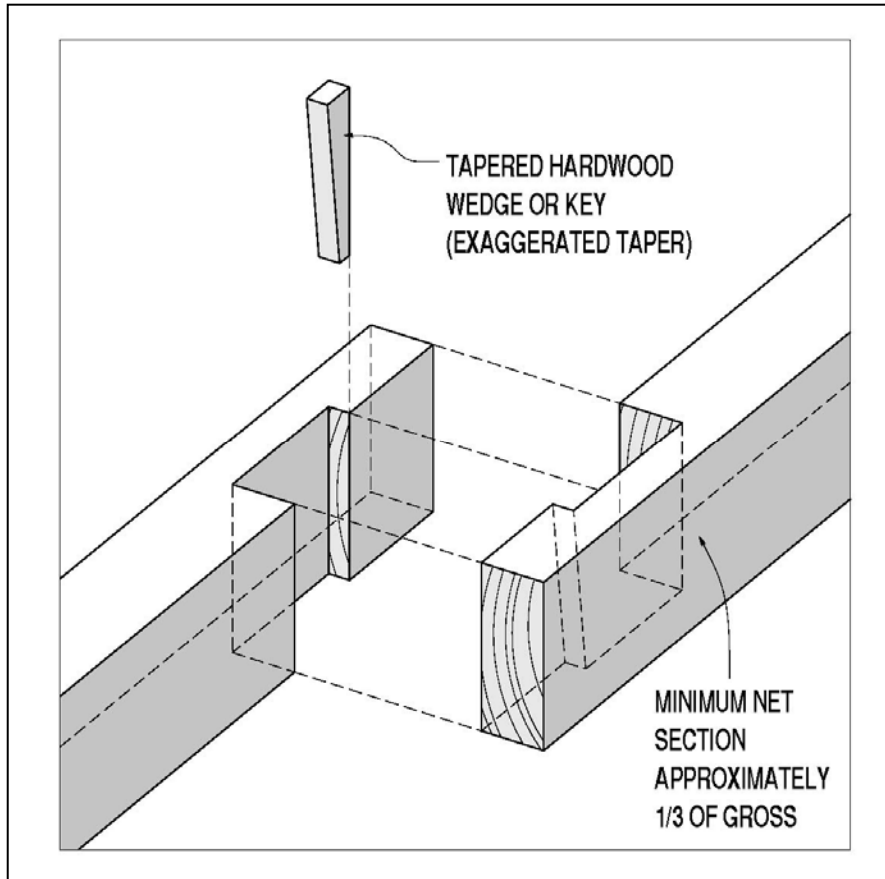

Figure 106. Lap joint with bypassing leaves and end grain bearing surfaces.

One relatively simple but effective way to increase the available tension capacity in a lap joint is to taper the breadth of the halves as the load is transferred from member to member. If the members taper from two-thirds of their gross section at the beginning of the splice to one-third at the end of the splice, the through connectors might weaken the splice to only one-half of each member's gross tensile capacity. Again, both through-plane and in-plane shear connectors can be used to transfer the axial tension from one member to the other. Figure 107 shows a lap joint with tapered halves and connectors.

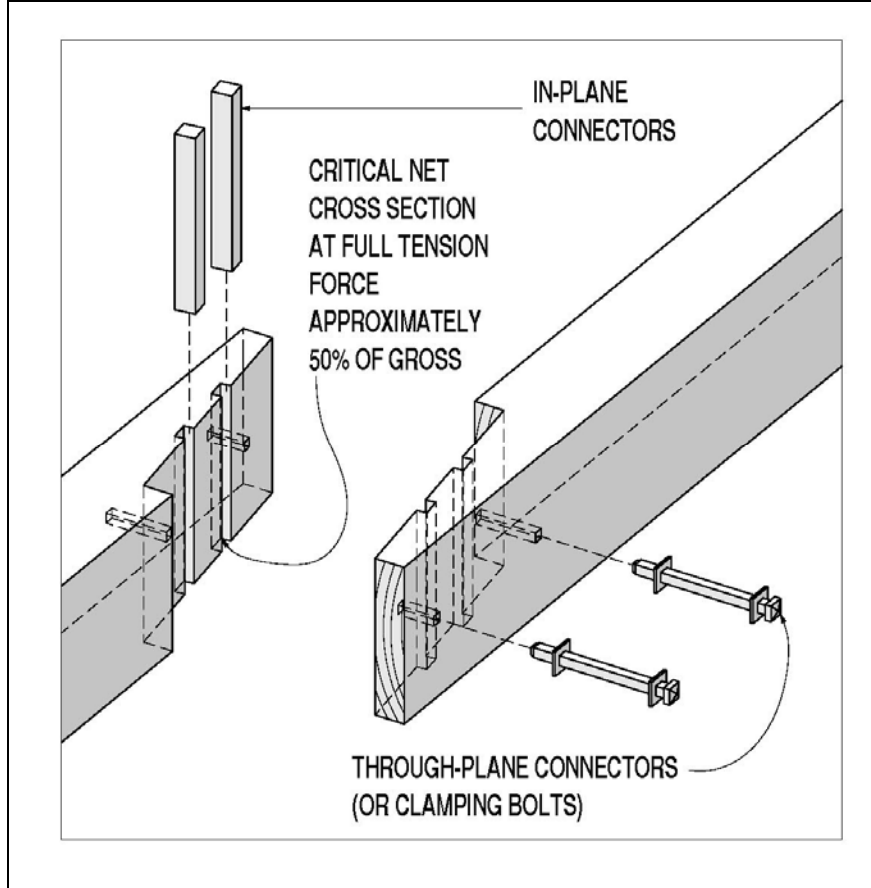

Figure 107. Lap joint with tapered halves and connectors.

Within the family of tension lap splices, perhaps the highest form in efficiency, required craftsmanship, and artistry is the bolt-of-lightning splice (see figure 108). This joint is a tapered, end grain bearing splice with multiple bearing faces. The bearing faces are not cushioned with side grain bearing wedges or keys, and each of the mating faces must be scribe-cut to fit. Furthermore, if only one of the faces is overcut, one of the members would have to be replaced.

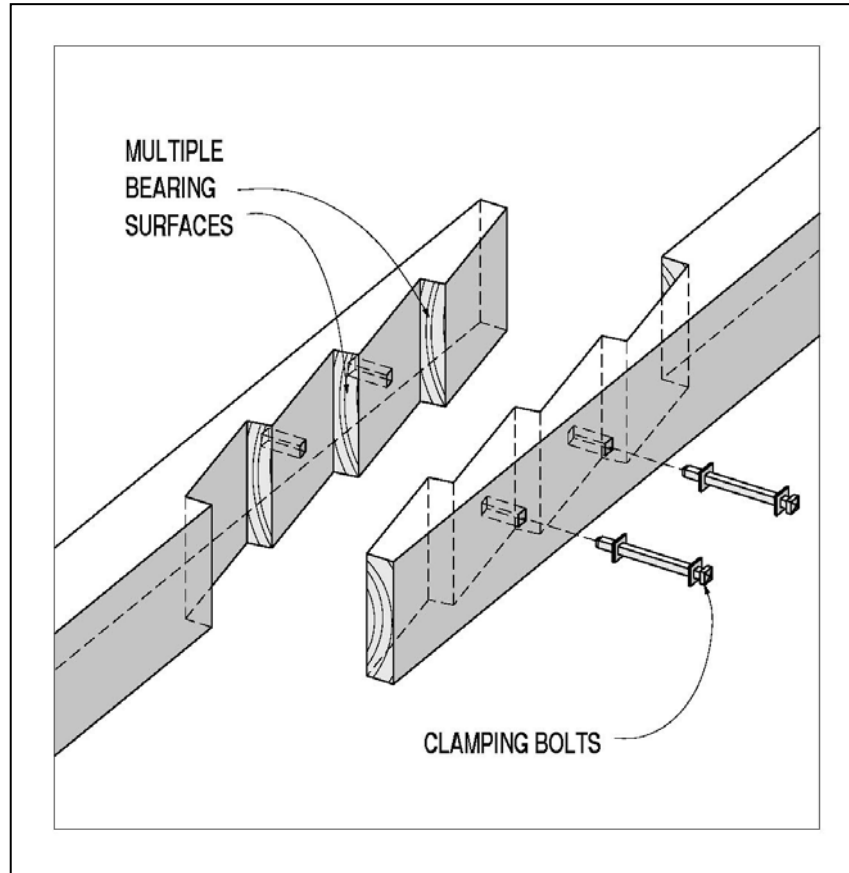

Figure 108. Bolt-of-lightning joint.

All lap splices, from simplest to most complex, share an innate design consideration—eccentricity. The eccentricity comes from two sources. The very halving of the members deflects the load path from the gross section centroid through the net section centroid within the lapped zone. The in-plane connectors also will induce prying forces in response to the eccentric load flow paths through them. The connector eccentricities require clamping through-bolts to hold the lapped members together. The overall eccentricity also induces secondary moments about an axis in the lap plane, which can cause splitting, usually right at the necked transition from full to lapped member (see figure 109).

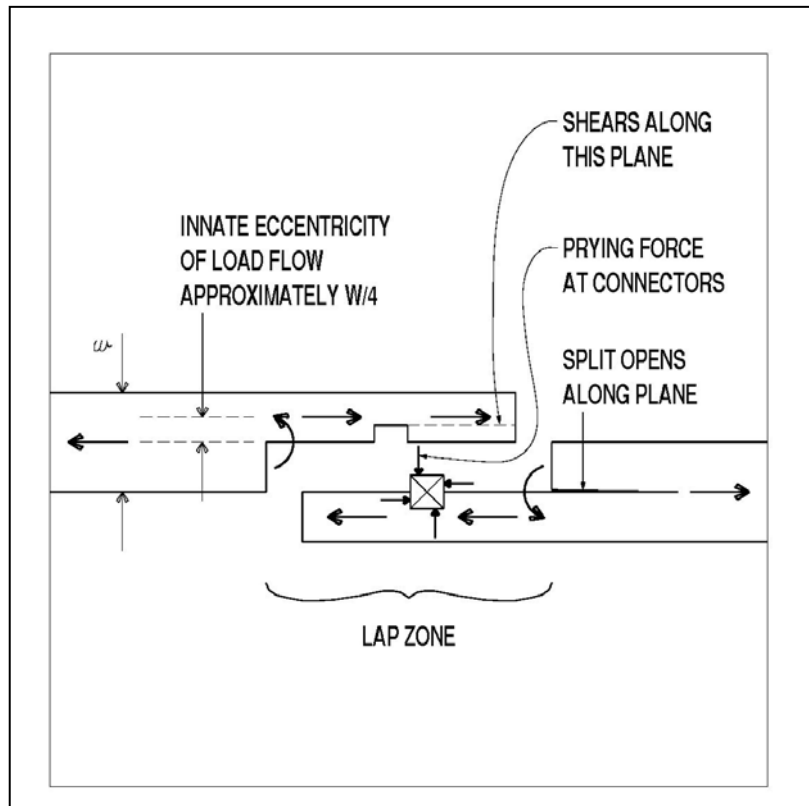

Figure 109. Eccentricity in member layout and prying at connectors.

Some builders tried to counter this splitting tendency with more through bolts or lags. Some of these clamping bolts were not threaded, because steel hardware was so costly, and the machinery needed to roll or cut threads was not commonly available. Instead, builders would use an eye-and-wedge connector, which was built at the local blacksmith shop (see figure 110).

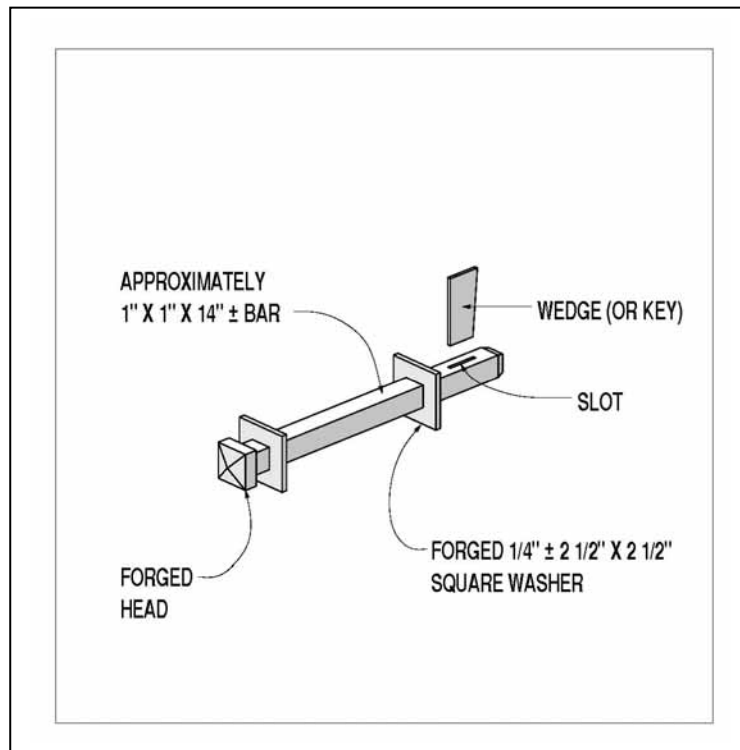

Figure 110. Eye-and-wedge clamping bolt, hand-forged.

One apparently simple but rare modification to the lap joint is the doubled lap, or slot and tenon joint. This connection represents an improvement in two ways over the entire family of simple lap joints. The through-plane connectors are loaded in double shear, with more than twice the capacity (generally) and increased stiffness over the single-shear use of the same connector. The innate eccentricity is also removed with this symmetric layout. Although through bolts still would be a wise addition, the clamping of the double leaved half resists the prying action generated at the connectors. If the leaves were also tapered, the theoretical capacity of this splice layout could approach 50 percent of the gross capacity, with greatly reduced eccentricity-induced influences (see figure 111).

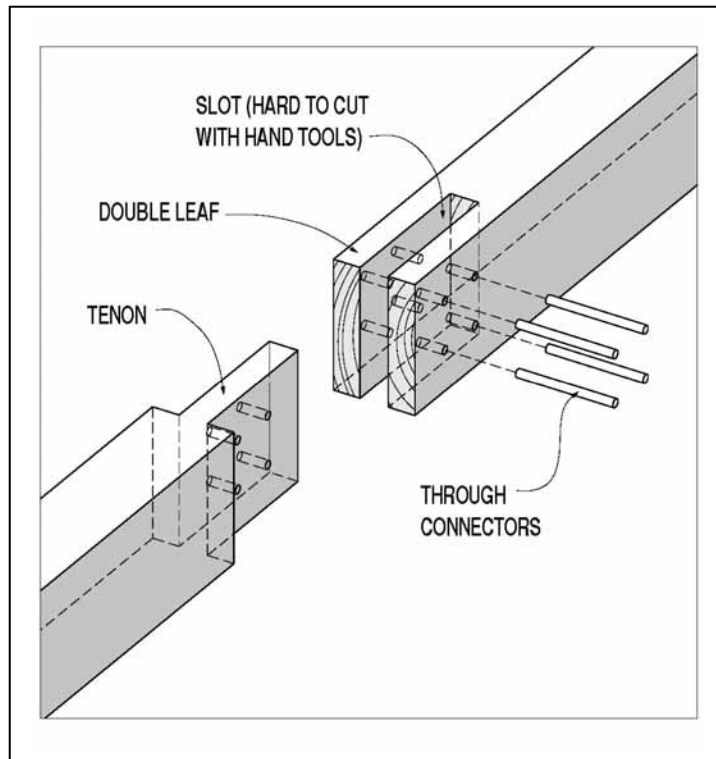

Figure 111. A double-leaf lap joint, with through connectors.

For various reasons, including fabrication and timber checking, timber joiners rarely used this double-leaf layout, but they gained many of the advantages of its straightforward load flow and doubly sheared connectors through various renditions of the fish-plated tension splice (commonly termed splice plates in metal truss bridges). In a fish-plated connection, the tension forces are not transferred directly between the two spliced members, but rather from one to the other through intervening members that are outside the butted gross cross sections of the spliced members. The simplest fish plates are two steel plates, through-bolted to the two members (see figure 112). This is a common repair method, but it is rarely used in original construction. This connection shares the fabrication and long-term maintenance problems described in the introduction to this section.

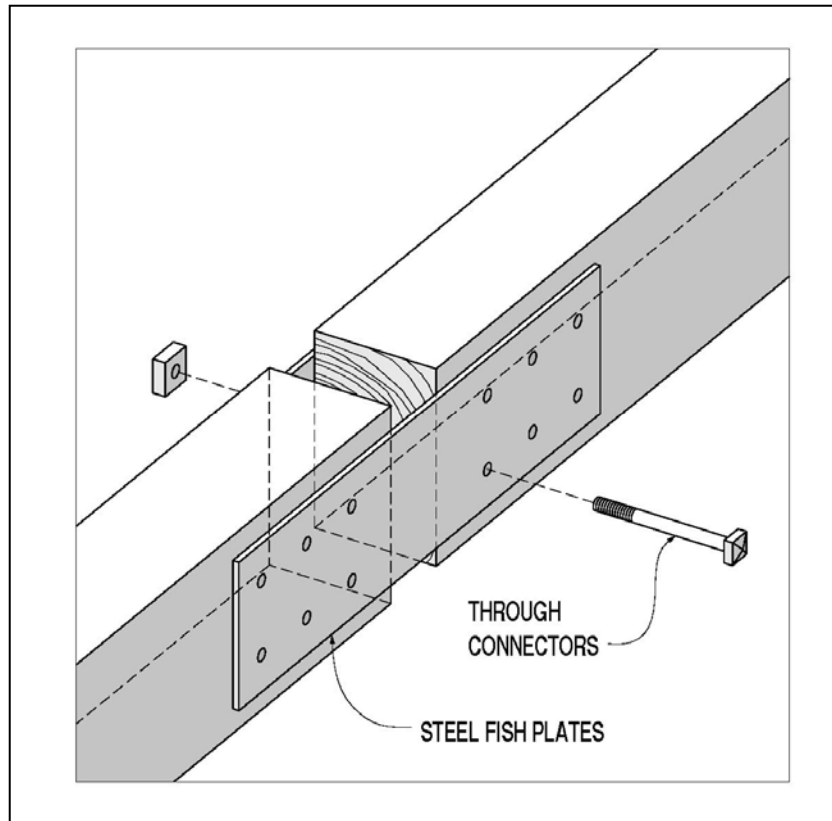

Figure 112. Butt joint with steel fish plates.

Original builders often used wooden fish plates that were clamped to either side of the tension chords and relied on end grain bearing faces to transfer the tension forces (see figure 113). The bearing faces could be fit and cushioned with side grain bearing keys and wedges. The shear lugs could also be tapered to generate full bearing faces with fewer and smoother reductions in the net section. In addition, the fish plates could have multiple bearing faces, resulting in a fish-plated bolt-of-lightning joint. These joints had one big advantage over executing the same joint in two lapped members: If one bearing face was overcut, only the fish plate had to be replaced to achieve uniform bearing faces, equally sharing the transferred tension forces. The theoretical tension capacity of these fish-plated connections can still barely exceed 50 percent of the gross capacity in the spliced members, depending on the relative allowable stresses in tension and end grain bearing.

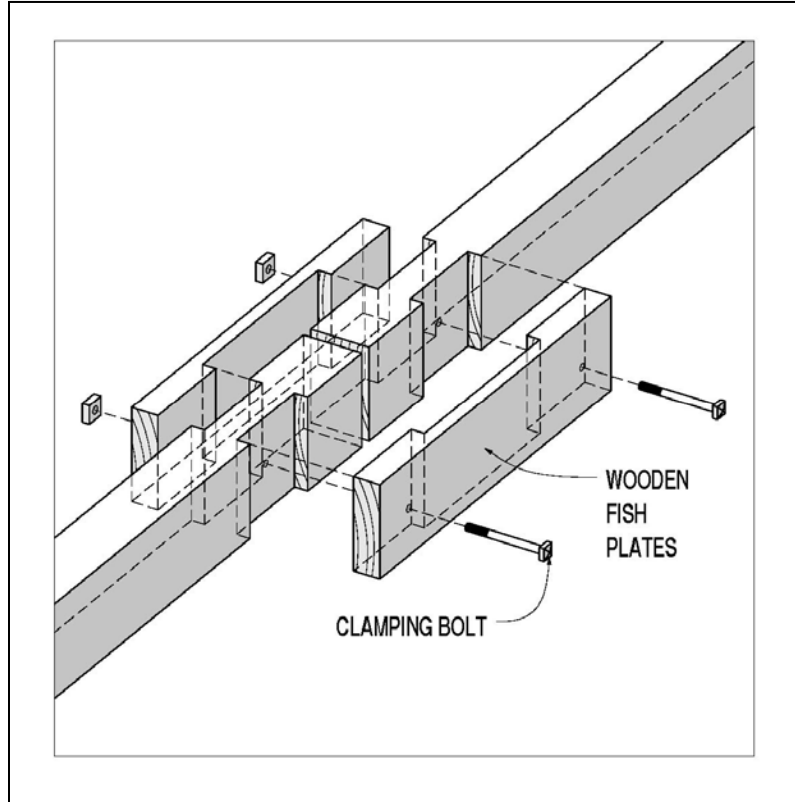

Figure 113. Butt joint with fish plates–wooden plates.

The bars-and-rods splice is a marriage between timber joiners and the blacksmithing crafts (see figure 114). A through mortise is cut (usually vertically through the member depth) a certain distance from the simple timber butt cut. A cast iron bar passes through this mortise and has holes at both top and bottom, beyond the timber cross section. Wrought iron or steel rods with threaded ends pass between the two iron bars and carry the tension force. Failure modes for this type of connection include bending in the bar, crushing in the wood bearing face, shear in the wood end grain, and fracturing or stripping threads in the rods.

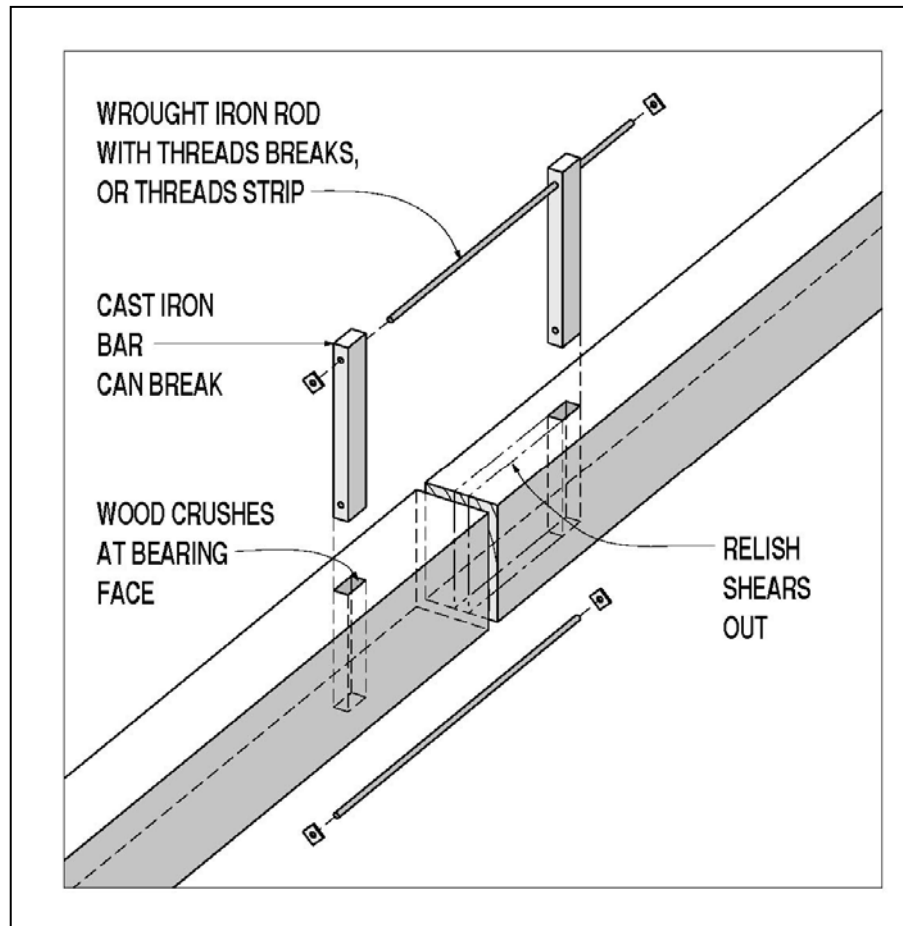

Figure 114. Butt joint with bars and rods splice.

Of course, no mechanical connection method can approach the capacity and stiffness generated in the straight wood fiber found in a tree. The best tension chord for a timber truss is a full-length single piece. Some very short bridges took advantage of this. For the longer spans that a heavy timber truss can handle, however, builders rarely had access to full-length tension chords. Some of the World War II-era bridges built on Oregon State highways have 30.5 m (100-ft) chord members. A few recent rebuilds of existing bridges have used full-length, glue-laminated timbers. Those projects have further illustrated the difficulties in handling these long and fragile members, even with modern roads, trucks, and lifting equipment. Even in cases where a tall enough tree might be available, the logistics of transporting a timber cut from its log to a convenient bridge site can be daunting enough to require builders to use various splicing technologies instead.

Compression Member Connections

Compression connections between coaxial members are often variations on the simple half lap, or lapped splice joint (see figure 115). Theoretically, one might assess the compression load bearing capacity of this joint as being close to that of a continuous timber. The two factors working against this are uniform bearing on and between the two separate bearing faces, and the allowable end grain bearing stress.

Achieving uniform bearing across each face, and even bearing between the two sets of bearing faces, is a true test of the timber joiners' abilities.

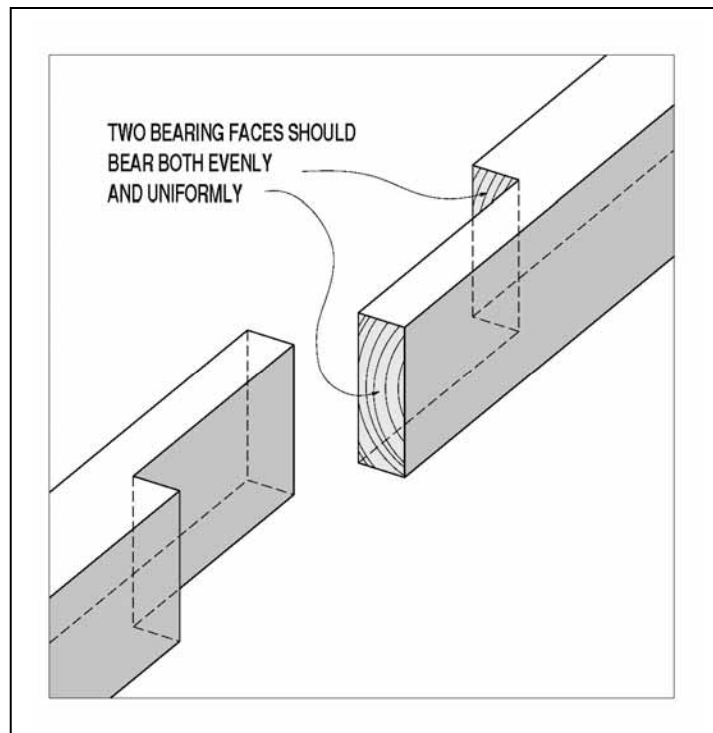

Figure 115. Simple lap joint for compression members.

One trick that the original fabricators had the luxury of using was kerfing to the line. This technique, described in Milton Grāton's book, involves fitting the splices in a long compression chord before cutting the intervening joinery to the other truss members.^[16] The two halves of the lap joint were cut to reasonably close tolerances and the two timbers mated and pressed toward each other as tightly as they will fit. The two timbers are clamped in that position, and a saw is run between them at both sets of bearing faces. This creates a pair of similarly sized and parallel-faced gaps at the bearing faces. When the timbers are unclamped and pressed together again, they should now bear uniformly and evenly. If they do not, the joiner repeats the process until the four faces bear well, uniformly, and evenly.

The NDS values for allowable end grain bearing have been reset to a maximum that is the same as simple compression along the wood grain. The NDS does permit an increase to this value, with the addition of some steel bearing plates. This reduction in allowable stress is reasonable, and reflects the reality that the wood fibers are interrupted along an entire cross section, making them free to crush into each other and not transfer the compression forces as directly and smoothly as do the naturally overlapping cells and fibers.

Connections of Diagonals to Chords

Generally, tension connections are detailed more easily between members that are perpendicular with (or parallel to) each other, rather than at an acute or oblique angle. Most timber trusses, therefore, are designed with compression diagonals and tension verticals. Furthermore, the diagonals generally frame into the verticals, rather than directly to the chords. This eccentricity can tend to shear the verticals, but offers tremendous simplifications and stronger connections. The result is that this subsection primarily describes only the heel, or end, connections found in queenpost and kingpost trusses, yet is applicable to other more generic locations, as the title indicates. These connections are, simply, examples of the most heavily loaded version of the classic truss connection: the last diagonal before the support reaction. Another categorization would be connections in which compression force is transferred between two

timbers that are in-plane, but at an angle with each other—not coaxial, in other words. Given the large component that timber truss dead loading constitutes, the end diagonals are usually the most heavily loaded compression members in the truss. The structural issue is determining how to keep that last diagonal from sliding off the end of the bottom chord. The classic connection at the heel joint in queenpost trusses has long been a notch in the top face of the bottom chord(s), cut at an appropriate angle for equal bearing stresses in both members, and secured with a centered clamping connector (see figure 116). The allowable bearing stress in wood varies from maximum (when parallel to the grain) to minimum (when bearing on side grain). Between those two limits, the transition is not linear, but is modeled with Hankinson’s formula (a commonly known formula used to calculate loads at an angle to grain.) The optimal angle for the bearing faces occurs when the angle between the grain and the bearing faces is equal in both members of the connection. The bottom chord is the more critically notched and loaded member of the two involved in this joint.

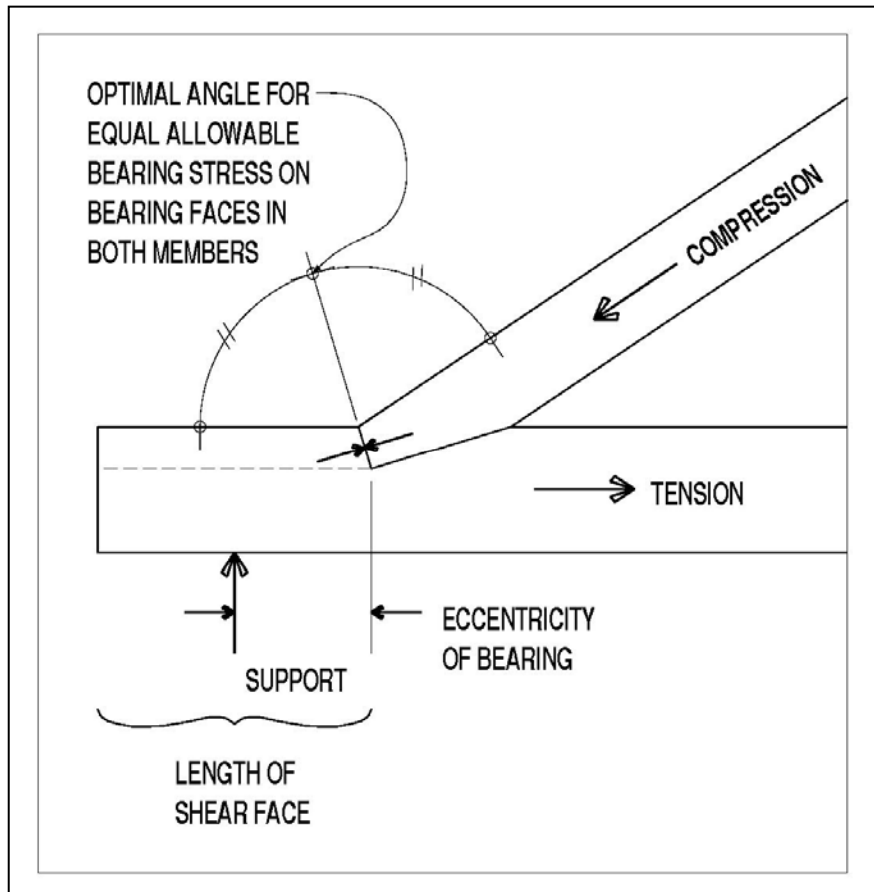

Figure 116. Simple bearing joint at angled notch.

The stresses that need to be considered at the bottom chord notches include:

- Net tension across the reduced cross section at the notch.
- Combined stresses due to bending induced across that same section by an eccentric load path in that tension force.
- Shear stresses in the plane that resist the end of the bottom chord, simply shearing off beyond the notch.
- Any net direct bending stresses that might be induced by the bottom chord's being supported beyond the notch cross section.

This last consideration is a prime reason that original builders used bedding timbers to cushion the point reaction at the supports, while providing some distance along the bottom chord for resisting heavy bending and shear stresses induced by the joinery design. Another way to view this connection is to recognize that the support reactions are the largest point forces applied to the trusses. The high forces transmitted among the members in this area mean that these connections will be the most difficult to design, no matter what truss format is used. The pegs in Town lattice trusses, for instance, are much more heavily loaded in shear near the supports than anywhere else in the truss.

Connections of Verticals to Chords

Connections between truss verticals and their horizontal chords will be, by definition, joints where the members are perpendicular to each other. Generally, the primary force resisted is the tendency for the lower chord to be pulled off the bottoms of the verticals, and the shearing force is transmitted from the diagonals to the chords, through the verticals. A common feature found in connections between vertical elements to both upper and lower chords is the bearing face table, usually in both members. These bearing faces often are seen only in both members in the bottom chords of non-Town trusses. The single top chord in most timber trusses is suited only to provide bearing faces in the vertical plane—along the mortise-and-tenon ends and, possibly, the bearing at the table or housing in underside of top chord timber. These interlocking dadoes lock the joint together against both vertical and horizontal relative movements. The forces are transferred between the connected members through bearing between end grain and side grain faces (see figure 117).

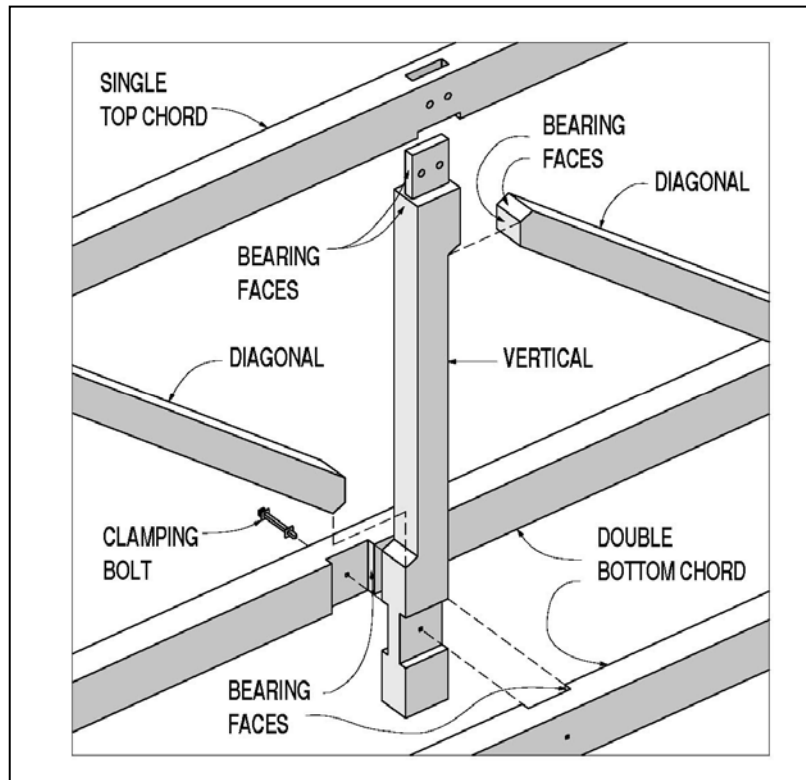

Figure 117. Top and bottom chord connections to vertical.

In addition to the often large, in-plane longitudinal truss shear forces that must be transferred at this joint, the connection between bottom chords and verticals often transfers vertical loads from the transverse floor beams that bear on the bottom chord into the truss verticals. These live and dead gravity loads can be substantial and must be transferred into the truss verticals to prevent inducing undue secondary bending stresses in the truss bottom chords. The original builders prevented the bottom chord from sliding down the vertical by making clever double use of the multiple bottom chords, through double tables that bear on the blocks remaining on the exposed bottoms of the verticals. For this bottommost truss element to have adequate shear capacity against these vertical reactions, they must have sufficient length in the tail hanging below the truss. The exposed lower tails in these truss verticals often hang at least 250 mm (10 inches) below the bottom surface of the bottom chord. This critical but exposed component can be subject to the most intense damage by floating debris during high water flows.

Connections between Diagonals and Verticals

The heavy timber truss verticals often were crafted with corbels where the verticals receive the largely compressive diagonals at simple bearing face connections. This means that the total width of the vertical, at its ends, is several inches wider than its net width along the central portion between the notched corbels. In other words, the net section is reduced between the bearing faces at the tops and bottoms of these tensile members. The vertical component of the compression force in the diagonal is resisted by shear parallel to grain along the length of the corbel beyond the bearing face. It is common that some of

the more heavily loaded (nearer the span ends) vertical corbels have failed in shear along this section—a condition that can be very serious and should be addressed immediately, as depicted in figure 118.

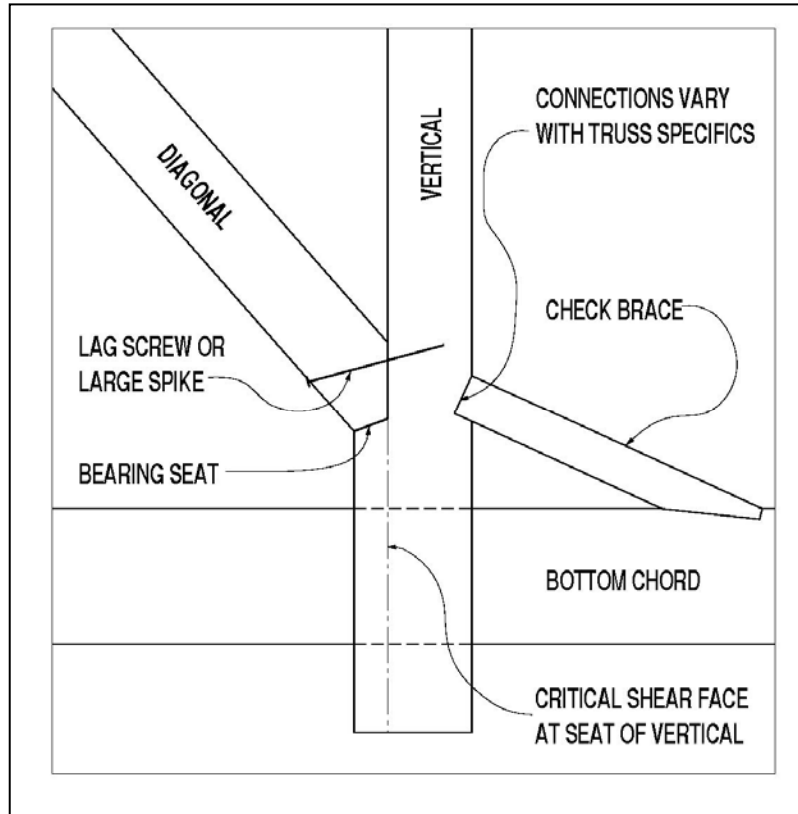

Figure 118. Truss vertical at bearing seat with critical shear face.

Unfortunately, it is not easy to repair a vertical with corbel shear failure. Some have attempted to repair the failed shear plane with epoxy adhesives. Others have installed bolts in single shear through this face, but this will rarely provide sufficient capacity to restore the connection to a safe condition. Still others have sistered another diagonal within the original one, bearing on a newly cut bearing face in the vertical member. This induces even more eccentricity in the connection force layout, with increased bending in the vertical member. Figure 119 depicts a sistered diagonal.

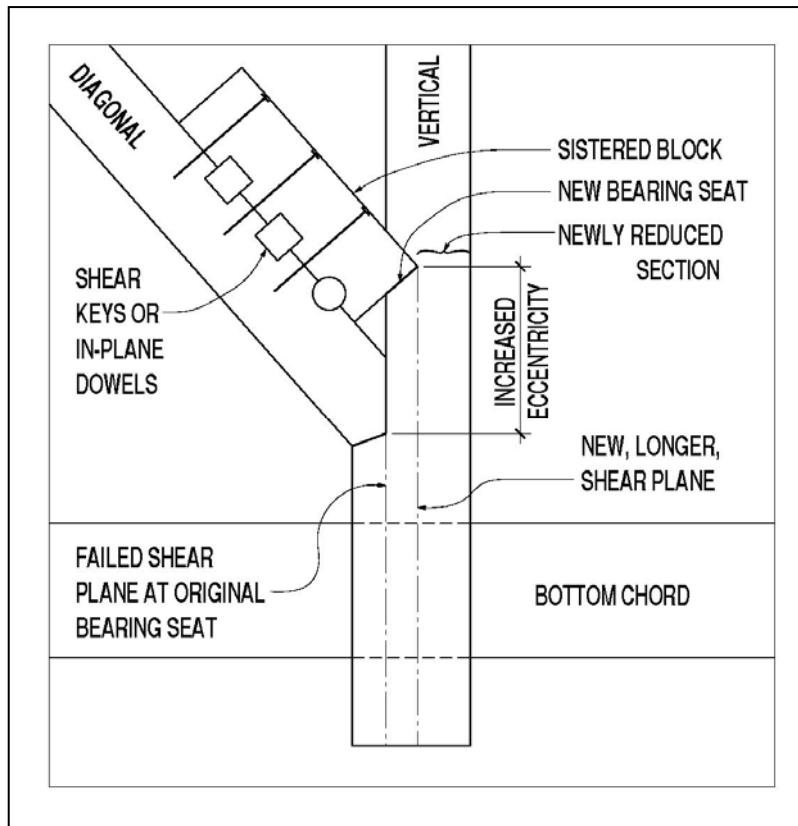

Figure 119. A sistered diagonal.

The most practical solution is often total component replacement, a solution that usually requires false work supporting the structure while the truss is partially disassembled in the vicinity of the vertical needing replacement.

Similar to the stresses induced in the queenpost bottom chords at the supports, the verticals in these paneled timber trusses need to be investigated for some secondary stresses. The innate eccentricity at these joints greatly simplifies their crafting and bearing surfaces, and reduces the shear that the vertical to chord connection must resist, but these gains are made at some cost. The horizontal component of the diagonal compression force induces bending and shear stresses at the reduced net section in the vertical. Furthermore, the combined tensile stresses should be checked for net section at the notch, because the secondary bending stresses caused by eccentric load paths can be even more damaging. Not only are these stress combinations complex, but the designer must confront some fairly complex and cloudy load flow and transfer geometry, when considering how the vertical is restrained by the chord member just beyond this connection to the diagonal. Some original timber truss builders and many subsequent builders addressed this connection eccentricity by introducing check braces on the face of the vertical opposite the diagonal. These braces, typically at flat angles, can carry the horizontal component of the diagonal's compression very efficiently through the vertical, into the check brace, and then into the chord member. See figure 118 for an illustration of these fairly common reinforcing braces.

Supporting and partially disassembling heavy trusses in situ can be difficult and expensive, so many rehabilitation efforts avoid this process. Partially replacing the failed bottoms or tops in the verticals has been common in a variety of truss types. Because the verticals are usually resisting substantial forces, even if simply generated through dead loads, splicing the partial replacement is an operation demanding careful design, detailing, and execution. Repair connection methods include using timber shear keys, or pegs drilled in the lapped planes, in combination with bolts to hold the components together. These clamping bolts must be designed to resist the prying action caused by the eccentric load path through the

single shear passing through the mechanical connectors within the shear plane. The size of the prying force is a function of the number and loading within the connectors, as well as the length-to-thickness ratio of these shear keys or dowels.

The common problems with corbel shear in the ends of truss verticals led to using wooden pegs to reinforce the critical shear plane. Figure 120 shows an installation that increased the vertical capacity of the joint by about 15 percent. Unfortunately, wooden pegs are not common enough to have standard allowable stresses. Furthermore, the wooden dowels, loaded in single shear, seem likely to be significantly less stiff than the original shear plane. This means that the shear plane area is reduced by the cross-sectional area of the peg holes drilled through it. However, the pegs might not be considered to be bearing much load until after the shear plane has failed and displaced. This load sharing between disparate but parallel interconnection methods, based on their relative stiffnesses at various load levels, is a common problem for designers who conscientiously combine connection methods within a single joint. The most reasonable, but conservative, approach would be to design the added shear connectors to carry the entire design load, without relying on the stiffer, but more brittle, along grain shear capacity in the corbel block shear face.



Figure 120. Example of pegs added to increase the shear capacity.

Timber Counter Connections

Timber counter members are found in only a few truss types, including Long trusses and Howe trusses. Figure 121 shows a Long truss with counter timbers. The dual diagonals are the main compression diagonals; the single diagonal elements are the counters. Unlike the steel rod counters used in classic through truss bridges, timber counters are expected only to act as compression members, and the simple butt-fit bearing face joinery can transfer only compression forces. The stress reversing effects of moving live loads can loosen these timbers, as they inevitably fail to carry induced tension forces. Timber counters are often toe-nailed in place, with relatively light steel fasteners, to keep them from falling out with heavy moving live loads.



Figure 121. Long truss with counter timbers.

When timber counters were used, initial installation usually involved matching bearing wedges—often at the bottom end of the counter member—which could be driven (and adjusted, even much later) to produce a desired tightness, or precompression, in the counter member. Unlike metal counters that can be adjusted to a desired force level by measuring with strain gauges while tightening an adjustment linkage, timber counters are usually installed or retightened solely by judgment and experience. A popular and simple approach involves intentionally shaking the counter timber. If it feels loose, then the wedges are driven against each other, causing more resistance when shaking the element. This is not a high-tech method, but it is practical and sufficiently effective for most covered bridges with counter members.

Apparently, the matching wedges at the counter ends were rarely secured with nails or screws when they were originally installed. Current rehabilitation projects often involve adding these fasteners to prevent the wedges from working loose under the load reversals induced by traffic live loads. Screws offer the advantage of being easily removed when additional adjustment is subsequently required or desired.

Bearing Blocks in Howe Trusses—Diagonals and Verticals at Chords

The Howe truss was the first patented truss type to use metal in primary truss components in concert with the majority of members still made from timber. The vertical tension elements were made with wrought iron rods with threaded ends that allowed the builders and owners to tighten the truss panels against the wooden compression diagonals and counter members. This adjustable feature accommodated more variation in assembling prefabricated elements, simplifying and speeding bridge fabrication and construction. The connection blocks used on the first Howe trusses were hardwood. Later versions of the Howe truss took advantage of mass-produced cast iron shoes.

The Howe truss was quickly adopted for use on the developing railroad network in the 19th century because it could easily and quickly be built of components that were mass-produced offsite and erected onsite with the easily adjusted vertical rods to tighten the trusses. Because the railroads were large and wide-ranging, the Howe truss bridge details were often standardized. Examples of high-quality technical drawings of those standardized details are more readily available than any other early heavy timber truss.^[15]

Long Truss Wedges

The Long truss is notable because it relies on bearing wedges between the truss verticals and the chords. These wedges are not particularly consistent and may or may not be present in the top chord connection. The top chord wedging apparently depended solely on the preference of the original builders. Many covered bridge scholars have proposed that these wedges were originally intended to allow the builder to adjust the overall truss geometry (and thereby, internal forces) in an early example of structural pretensioning. However, recent work on a covered bridge in Hamden, NY, demonstrated that these wedges may be far more important in distributing large, cross grain bearing stresses from the verticals into the chords. More discussion of this topic is available in an article about repairing this particular bridge, contained in appendix B.

Truss Connections—Town Lattice Trusses

Traditional Lattice—General

The construction feature that perhaps most distinguishes the Town lattice from other truss configurations is the absence of complex timber joinery. Indeed, the design philosophy behind this truss was to substitute more standardized material joined with much simpler connections than were used in any other of the patented heavy timber truss types. In the Town lattice truss, precise cutting of relatively few heavy timbers is replaced with large quantities of repetitive drilling and pegging among much lighter planks. The traditional plank lattice truss used members that were usually cut from nominal 3x12s or 3x10s (75x300 or 75x250 mm). These planks are connected in a lattice framework comprised of two adjacent central layers of parallel lattice elements, overlaid in opposing directions. This lattice core is sandwiched between pairs of layers of upper and lower chords, forming an overall six-layer plank truss.

One feature of Town lattice truss layout involves the relative symmetry of the web lattice members in the two longitudinal trusses. If the trusses are identical, the inner web planks on one truss are opposed to the inner layer on the other truss. If they are mirror images, the two trusses have inner and outer layers that are parallel to each other. Figure 122 shows Town lattice trusses with identical versus mirrored web members. Some bridge analysts and owners have noted or predicted that those Town lattice truss bridges with mirror-imaged trusses are more prone to stay in longitudinal alignment.

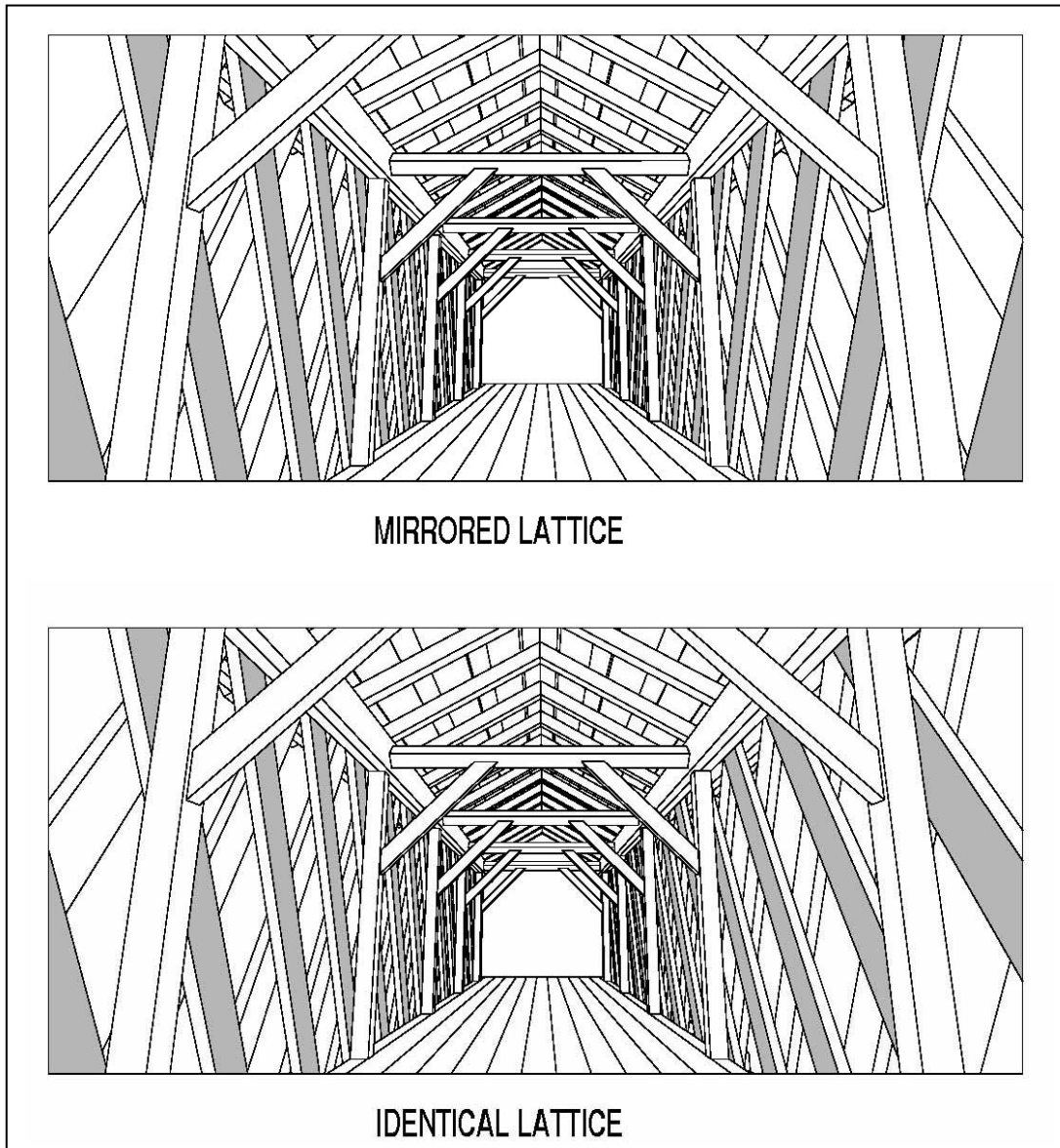

Figure 122. Town lattice trusses with identical versus mirrored web members.

A few of the larger and longer Town lattice trusses were built with only a single chord element on each side of the lattice web or core. These large, sawn members had to be spliced together, using one of the many forms of tensile and compressive element splices discussed earlier. One of the more notable examples of this type of truss variety is the Windsor-Cornish Bridge over the Connecticut River between Windsor, VT, and Cornish, NH, rebuilt in the early 1990s to support two lanes of truck loading.

In general, the Town lattice trusses originally were connected only with wooden pegs (termed trunnels, derived from the term treenails) at each of the intersections between elements. The pegs are in groups of as many as four in the chord to lattice connections, and one, two, or even three pegs at the simpler interlattice connections. The interlattice pegs are loaded in simple single shear, but with some complexity added by the entirely possible moment constraints about a horizontal axis through the peg group centroid. The peg patterns at the chord-lattice intersections perhaps experience simpler forces, but they are complicated by passing through as many as six separate members, with five distinct shear planes. These are not doubly sheared pegs, but ones in multiple single shear conditions, with the shearing force pointing

in different directions at each shear plane—a very complex loading state on any single peg. Rehabilitation projects in the latter part of the 20th century occasionally used large steel bolts to replace the original wooden pegs. This practice is not necessary and sometimes even harmful to the bridge, because it dramatically alters the original relationship of wood against wood bearing.

Chord Terminations/Butt Joints in the Chords

The traditional Town plank lattice construction used planks for the chords that were not particularly different from those used in the web members. Indeed, this multiple potential use was a prime feature of the Town lattice truss. It allowed for simpler lumber orders, while still permitting the builder to sort for the higher-quality timbers for use in the more stressed zones. This meant, however, that individual pieces of the chords generally were not very long. In keeping with the prevalent simple connection details in this truss type, no splicing was made between individual, coaxial, tension chord elements, at least not in the traditional sense of the word “splice.” Instead, one of the chord pairs on either side of the lattice was simply terminated. These simple chord butt joints were usually staggered carefully and evenly along the bridge span. In simplified concept, the adjoining chord element at each of these butt joints must be picking up the extra load that had been shared with its twin. Clearly, if the twin elements terminate too close to each other, the load shifting between the two halves of the paired chord will not be effective.

As relatively simple as they all may seem, each Town lattice truss is unique in at least some ways. The truss’s behavior strongly depends on the length of the individual chord elements; the size, angle, and spacing of the lattice members; and the number and diameter of pegs used at the connections. The surviving original Town lattice trusses were typically built with individual chord elements that were at least 9 m (30 ft) long. The load sharing and transfer required between the paired chord components is critical and benefits from longer chord elements; those built with shorter chord elements would not have lasted as long as those built with longer elements. The longer chord elements reduce the overall number of the weakened splice cross sections while allowing more mechanical interconnections between adjacent chord terminations. The longer elements also permitted more advantageous positioning for the staggered terminations among the four chord lines, to minimize the number of butt joints in any one cross section of the full chord.

Refined computer model analysis and strain gauge field measurements have demonstrated that some portion of the axial forces in an interrupted chord is transferred through the trunnel connections to lattice members to the pair of chords on the opposite side of the lattice truss. Further generalization about the load sharing among various chord elements in Town lattice trusses is difficult, because it depends on the length of individual chord elements, their joint locations, and the strength and stiffness of the trunnel connectors. More discussion of this work is available in the article, “Those Intriguing Town Lattice Timber Trusses,” presented in appendix A.

Another structural aspect related to the lower (or tension) chord ends is the gap size between the two chord elements at their terminations. Given the dominance of the truss’s uniform dead load, the chord forces are larger toward the middle of any truss span. The upper chords are in compression and tend to close any gaps between the ends of members. The lower chords are in tension, which tends to widen any gap. The gaps at the terminations in both upper and lower chords nearer to the abutments, with their reduced axial forces, indicate the tolerances met by the original fabricators (or subsequent repairers). The authors have inspected many of the authentic covered bridges in the United States and have found that the original joint fabrication tolerances were quite good, to 3 mm (0.125 inches). A small gap at a tension chord termination indicates that the truss is operating within stress levels; this further implies a reasonable safety factor. Some bridges exhibit distinct gaps (larger than 25 mm (1 inch)) between the tension chord ends. Gaps this large can only occur when the wood surrounding the nearby trunnels crushes and/or the trunnels themselves crush or bend. While a 25-mm (1-inch) (or more) gap between the ends of tension chord elements raises reasonable concern for structural inspections (see figure 123), smaller gaps (6 mm (0.25 inches) or less) are not generally cause for alarm.

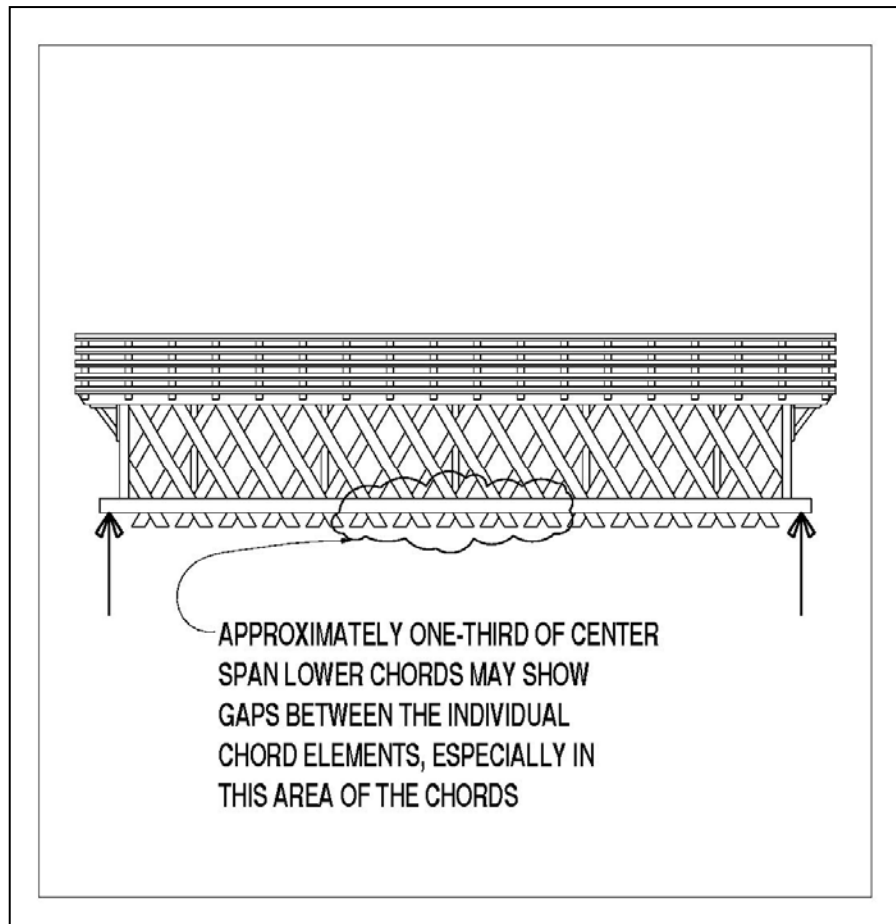

Figure 123. Town lattice truss connections need to be inspected carefully.

Chord to Lattice Connections

The connections between the chord and lattice elements must rely solely on the shear capacity of the trunnel patterns to transfer the forces from one element type to the other. Because the lattice members end just past their connection to the chords, all the forces (axial and shear) remaining within the lattice members must be transferred to the chords at that connection. Similarly, the horizontal force components in the chords on one side of the lattice elements must be transferred via the trunnels at those lattice/chord connections adjacent to chord element terminations.

The finite element computer modeling cited above consistently and clearly indicated that the most heavily loaded trunnel connections in any lattice truss span are those directly above the supports and closest to the front edge of the abutment. The total shear forces in these trunnels can be many times higher than those found in any other trunnel location within the truss. This uneven trunnel loading has led some Town lattice truss designers, analysts, and builders to advocate using more trunnel connectors at the span ends, and fewer in the center portion of the truss span. One might use four trunnel connections in the end quarters of the span and three trunnel connections in the center half of the span, for example. Some trusses even varied the lattice member spacing and breadth along the span length, further reflecting the varying shear forces along a span.

Another structural issue involved with the connections between lattice and chord members is transferring the transverse floor beam end support reactions, via bending and shear in the inner bottom chords, into the truss as a whole. Floor beams that extend through the lattice elements and are fitted to bear on all four lower chord elements can transfer their support reactions to the trunnels more uniformly. In many bridges, however, the floor beams bear only on the innermost bottom chord pairs, thereby adding substantial shear and bending forces to those trunnels that connect that inside pair of chords to the truss as a whole.

All these force transfers mean that the stresses in the trunnels are a very complex composite of shear and bending. This situation is induced by longitudinal and vertical distribution of forces among and between the many elements in a truss chord to lattice intersection.

Lattice to Lattice Connections

The refined computer modeling cited above has not indicated that high shear forces are being transferred by trunnel patterns within any lattice to lattice connections. In practice, most of these interlattice connections have been made with a pair of trunnels, although some are made with only single trunnels, while others are made with three peg patterns.

Bolts Versus Wooden Pegs

As described in the introduction to this subsection, traditional Town lattice trusses were assembled and connected with wooden pegs that were usually 37 to 50 mm (1.5 to 2 inches) in diameter. Minimal technical information about how these wooden dowel connectors behave pegs has been published in North America. Robert Fletcher and Jonathan Parker Snow published valuable information about timber-covered bridges in the late 1800s, based on Snow's extensive experiences on railroad bridges in New England. Their work includes some information on wooden pegs.^[17]

Milton Grāton, the renowned (and nearly only) authentic covered bridge builder in North America from the 1960s through the 1980s, published a book describing his life's work.^[16] That book cited the results of a few trunnel tests, and they were very specifically patterned on the connections he used to build lattice truss bridges. Those tests also apparently only determined failure loads, not connection stiffnesses. Robert L. Brungraber's unpublished, but available, Ph.D. dissertation also included some peg testing results, both strength and stiffnesses, in axial tension and compression, double shear, and bending loads.^[18]

William Bulleit, Ph.D., and Richard Schmidt, Ph.D., PE, have extensively tested pegs. Their research has been meant to determine those behaviors that will allow wooden pegs to be analyzed with the current NDS model for dowel connectors.^[19]

This model was, in turn, based in the Lateral Yield Theory methodology, which was first used in Europe in the 1970s. Section 11.7.1 of the 2001 NDS mentions how to address dowel connections with alternate materials or methods—opening the door to using wooden peg parameters to calculate shear capacities with code-approved methods.^[3]

As of this writing, however, there are no nationally recognized allowable design forces for these wooden dowel connectors. Pilot testing work, done in the mid-1990s, in combination with related finite element modeling, established that a reasonable single-shear allowable force for a 44-mm- (1.75-inch) diameter oak trunnel in a chord/lattice connection of 75-mm- (3-inch) thick pine is 6.7 kilonewtons (kN) (1,500 pounds) per shear plane. More testing followup would be helpful.

Most of the Town lattice trusses in authentic covered bridges have been rebuilt over the years. That work, at times, has been characterized by extraordinary care and was committed solely to replacing failed or deteriorated elements in kind. Some repair efforts involved substituting large diameter metal bolts for the original and traditional wooden pegs. The wooden peg connection functions through bearing between wood and wood, with effects on both the peg and the surrounding material. The steel bolt in wood

connection, with the much stiffer steel, often displays increased deformation in the surrounding wood material, with higher stresses in the wood at its edge, and relatively little bending of the steel (for the large diameter bolts used in this situation.) Some researchers believe that substituting steel bolts where there had been wooden pegs may actually weaken a connection, due to the higher edge stresses. The lack of any accepted standards for this connection type allows personal and professional judgment to influence preferred practice. The authors of this manual have not yet observed an instance where substituting bolts for wooden trunnels was either an obvious advantage or even necessary.

Diameter tolerance and the likelihood of uniform load sharing are two reasons to connect heavy timbers with larger diameter wooden pegs rather than steel bolts. The NDS specifies that steel bolts be installed in holes drilled up to 3 mm (0.125 inch) oversized, recognizing that wood may shrink as it dries, while steel will expand and contract with temperature shifts. Large diameter steel bolts are stiff, as compared with the connected timbers, so load sharing between patterns of bolts can be particularly uneven. One bolt, in a large group of similar bolts but installed in slightly misaligned holes, can be easily loaded with far more (or less) than a simple averaged share of the load. This uneven load sharing among large groups of heavy bolts has led to progressive collapse in large timber structures—particularly when the bolts were used in tension chord splices in timber trusses. Large wooden pegs, on the other hand, can be driven into tighter holes, even to the point of a mild interference fit. This means that all the pegs in a large pattern should bear more evenly. The reduced bending stiffness of the wooden dowels also helps the patterns of pegs distribute the loads more uniformly. Finally, wooden dowels do not condense moisture any more than the surrounding timber, reducing the risk of decay within the holes.

Sister Elements

Although not exactly considered a connection between two distinct truss elements, sistered lattice (or angled, web member) elements (newer supplemental elements slid into place along a deteriorated/damaged existing lattice element) fit into this discussion of Town lattice truss connections. Installing a new element adjacent to a damaged lattice member requires that the new one be connected in a way that effectively participates in the load sharing within the truss components. The original lattice elements were connected into the truss by trunnels at their intersection with the chords and with the intersecting lattice members in the other lattice layer. Those original trunnels helped transfer vertical and horizontal shear forces between adjacent lattice layers in the truss. Because the sister lattice elements are inserted along the original lattice member, their connections do not allow the mutual interconnection across all six planes of truss elements at the chord-lattice joints. The added trunnels at those intersections can only connect the four chords and the new single lattice and, therefore, do not provide an entirely similar connection to the other lattice layer, as found in the original construction. While these additional sister lattice elements have been used for many years, connecting them into the existing truss timbers is done more by judgment and less with benefit of any analytical investigations. See figure 124 for an example connection of a sistered lattice web at a chord.

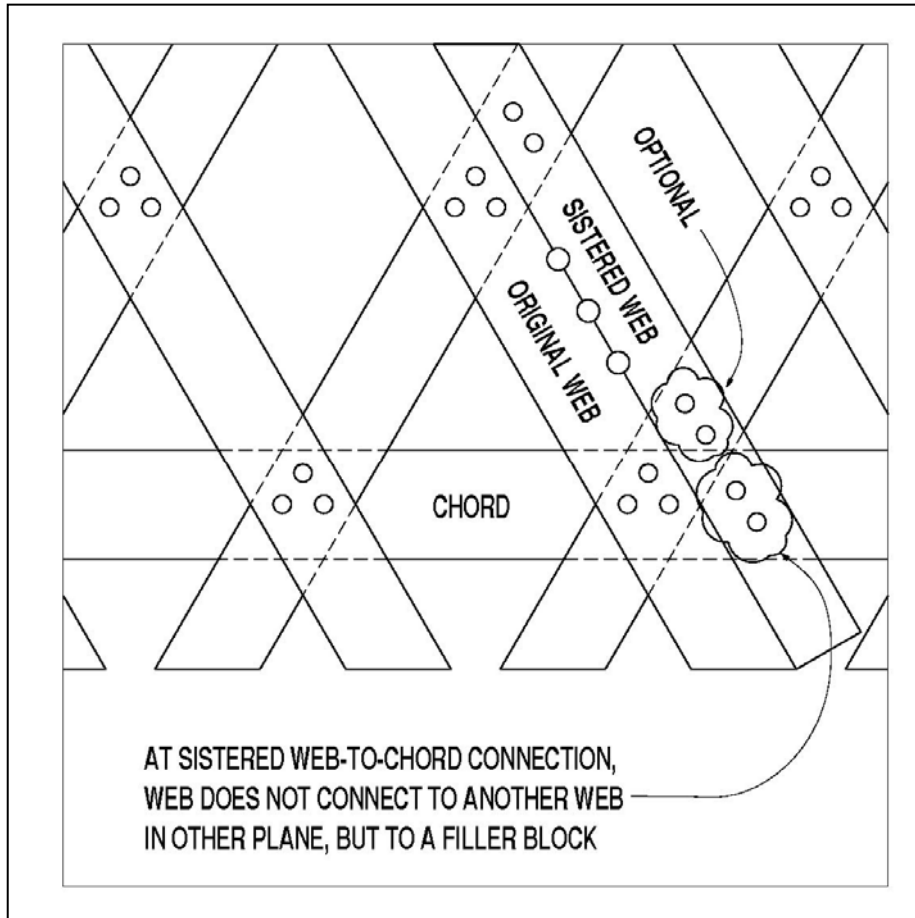

Figure 124. Sistered lattice web at chord connection.

Lattice Posts

One major and distinctive feature of the Town lattice trusses was that they could be “built by the mile,” meaning that the truss members could be extended and repeated for as long a bridge as the builders desired. This extruded nature also means that there is no single, obvious way to terminate a Town lattice truss. Furthermore, the builders’ choice for detailing the ends is rarely visible, unless the bridge is being repaired and the siding is removed. The truss ends need some type of auxiliary stiffening to help resist lateral buckling in the trusses and provide more support for the end portal bracing. Builders and rebuilders have used many methods to provide this end treatment.

Vertical Ends

The most common geometric treatment at the truss ends was to cut them vertically (at right angles to the chords, for those bridges on a longitudinal grade). This vertical end post often is made from the same plank members as were the chord and lattice members, and is cut to fill in the vertical gap between the chord ends at the truss termination. Many of these posts were made by extending all chord members to the truss end and filling the vertical openings with extra timbers around the lattice elements. The

strongest way to form these end posts, however, is to alternate the continuities of the post elements and the chord elements to knit the two groups of elements together, as shown in figure 125.

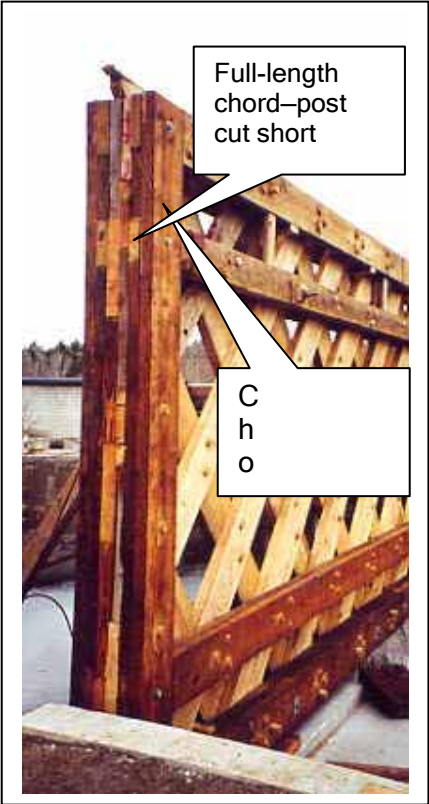

Figure 125. Built-up end post for a Town lattice terminated vertically–Paper Mill Bridge, Bennington, VT.

In some instances, the end posts were made from solid sawn timbers rather than planks. The chord members were connected to the posts, but the lattice members were cut short and not connected to the post timbers, as shown in figure 126.

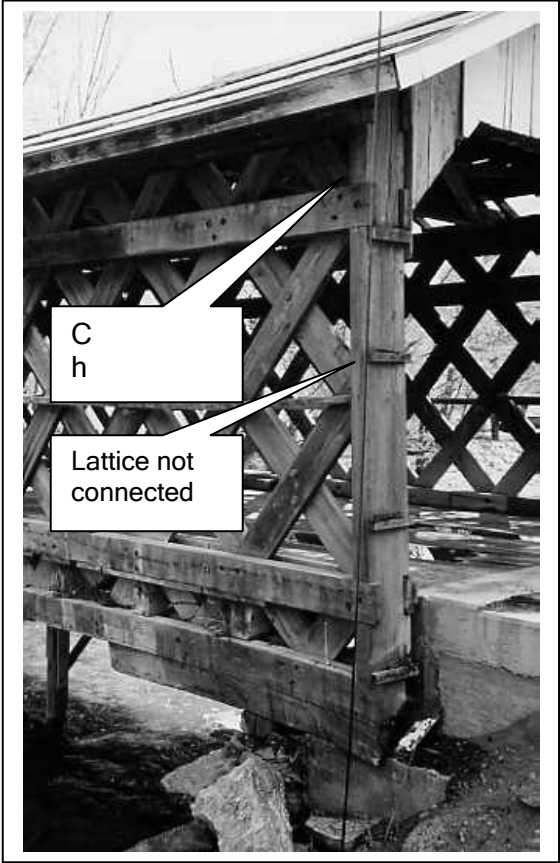

Figure 126. A solid-sawn end post—Fuller Bridge, Montgomery, VT.

Inclined Lattice Truss Ends

Many Town lattice trusses are finished with an inclined, overhanging end that follows the line of the lattice (see figure 127).

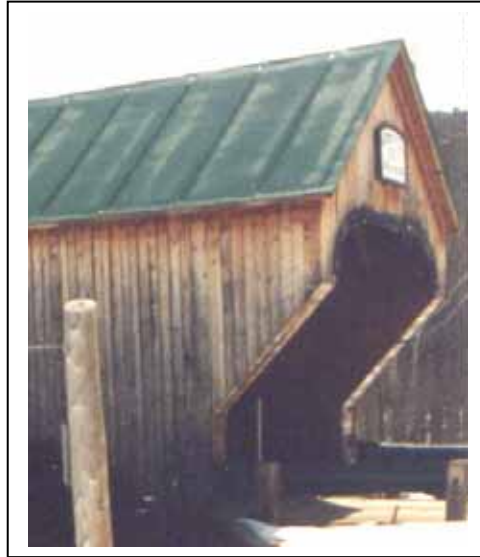

Figure 127. An inclined end treatment—Bartonsville Bridge, Rockingham, VT.

In these inclined end bridges, the trusses require end posts that are located back along the truss, where the trusses are still full-depth, and usually over the end support bearing points (see figure 128).



Figure 128. The corresponding interior end post—Bartonsville Bridge, Rockingham, VT.

Intermediate Lattice Truss Posts

In more rare instances, the posts are located at intermediate locations and were probably not included in the original construction. Figure 129 illustrates one example of this member layout.



Figure 129. Intermediate posts—Worrall's Bridge, Rockingham, VT.

Recommendations for Lattice Truss Posts

For the end posts depicted in the “Vertical Ends” section above, historic preservation principles usually indicate the need to repair or replace a solid-sawn end post, when it exists, to retain the practice of original construction. If the end post is built from smaller plank components, and if the repair process allows it (which depends on which chord elements are being replaced), the combination post—with alternating chord and post elements being continuous—produces a much stronger composite element. This shuffled method is preferred to end posts with all the chord members extended to the bridge end and the posts filled in from a collection of smaller components.

With the other post arrangements—either those near the ends of a truss with an inclined end treatment or those with intermediate posts (discussed in the “Inclined Lattice Truss Ends” and “Intermediate Lattice Truss Posts” sections, above)—the post components are interrupted by the chord members that must be continuous at that connection. The post components typically are solid sawn, with a thickness that equals a chord member pair. They are cut to fit tight at both top and bottom, wedged in each space between the chord members.

The intermediate posts located away from the ends of the spans may not offer much benefit to the truss load-carrying capacity, but they can offer extra lateral stiffness and strength to the bridge through the much stronger connection orientation for the knee brace connections. These intermediate posts may have been added during a partial rehabilitation of the trusses, in an attempt to avoid a more substantial lateral strengthening project.

Lattice Member Tails at Bearing Points

The tails of the lattice members extend below the bottom of the bottom chord members to provide an adequate end distance beyond the trunnels at that critical connection. If these tails were eliminated in the lattice members that are in tension, the connections would tend to fail through the lack of sufficient shear strength in the relish (shear plane) from the trunnel to the end of the lattice member. However, at the bearing areas, these tails are in the way below the bottom chord.

There are two ways to deal with this issue. The most common method is to cut the tails flush with the bottom of the bottom chord in that area. Because the largest lattice member forces at this area are in compression, the lack of an adequate tail does not weaken the truss in any significant way. After the tails are removed, bearing blocks can be installed beneath the chord members. Bearing blocks should be placed directly beneath the lattice intersections above the bearing area. At least two lattice-chord intersections should be supported in this way. The bearing blocks are full width, supporting all six planes of truss components. See figure 130 for an example.



Figure 130. Bearing blocks beneath the bottom chord where tails have been removed—Paper Mill Bridge, Bennington, VT.

The other way to deal with the lattice tails at supports is to keep them at full length over the bearing area. This could be accomplished in two ways. One method is to use a set of blocks under the outer chord pair and another set of blocks beneath the inner chord pair. It is difficult to shim the chords and blocks equally, so one side tends to bear more heavily than the other side. This introduces an eccentric load into the chord that causes torsion in the chord and uneven shearing in the trunnels. Rebuilders should avoid this detail, if possible, and shim carefully if they must use this split-bearing method.

A second way to detail split-bearing supports is to use a large solid-sawn timber with a groove cut into the top surface. This groove should be sufficiently wide and deep to allow the tails to protrude into the groove without bearing on their bottoms, while the chords bear on the outside of the timber. This detail is extremely rare and is not recommended, because the groove is a natural moisture and debris trap and will lead to early deterioration in the bearing timber.

Arch Bearing Pads and Arch Connections to Sandwiched Truss Elements

Theodore Burr is credited as the first to superimpose an end-bearing, two-pinned timber arch with a traditional multiple kingpost truss. Since his first patented layout, many covered bridges have seen various combinations of arches and timber trusses. Some arch/truss combinations have tied the arch with the truss members, eliminating the arch thrust from the abutments or piers. The arch members are terminated at the truss bottom chord and connected to that bottom chord, which further increases the tension in that chord.

The arch end bearing conditions at the abutments are generally routine. The final arch element should be cut at right angles to its longitudinal axis as it contacts the bearing, and its entire end face should bear on a concrete or stone pad attached firmly to the abutment. Good covering and flashing details, designed to prevent direct moisture exposure and any moisture retention at these critical arch bearings, are imperative to avoid premature decay in the vital arch ends. A relatively thin, pressure-treated timber bearing pad, or even a thin sheet of neoprene or similarly inert and dense material, should be used between the arch ends and the face of the concrete or stone. This isolation bearing pad is sacrificial, cushions the stress distribution at the arch end grain, and helps prevent end grain wicking of condensed moisture up into the crucial and vulnerable arch members.

The most common interconnection between typically doubled arch elements and the commonly sandwiched truss elements (or the asymmetrical single arch element) is a single bolt at the intersections of arch and truss verticals. In theory, a single bolt would provide a pinned connection between the connected elements. The practical aspects of moment transfer at this connection are debatable, however. When these bolts are removed, they are often misshapen, indicating some serious shear overload; the force transfer between the two distinct structural systems can be significant. A hand analysis of these interconnection forces, based on comparing the relative stiffnesses of the arches and the trusses, and the live load transfer from truss to arch, is not usually practical, or even meaningful. Even sophisticated computer modeling relies heavily on assumptions made about support conditions, relative stiffness of the various elements, and the behavior of the interconnecting dowels. Figure 131 depicts load sharing between the arch and the superimposed truss.

Those rehabilitating an existing covered bridge with arches and trusses might consider using a pair (or more) of bolts at the connections between the arches and the trusses. However, the breadths of the bypassing components may prevent using two connectors, because the single bolts often do not meet the current specifications for minimum loaded edge distances in code-approved bolted connection geometry requirements. At a minimum, the analysis must recognize the capacity limitations of the actual joint details and avoid making inconsistent assumptions.

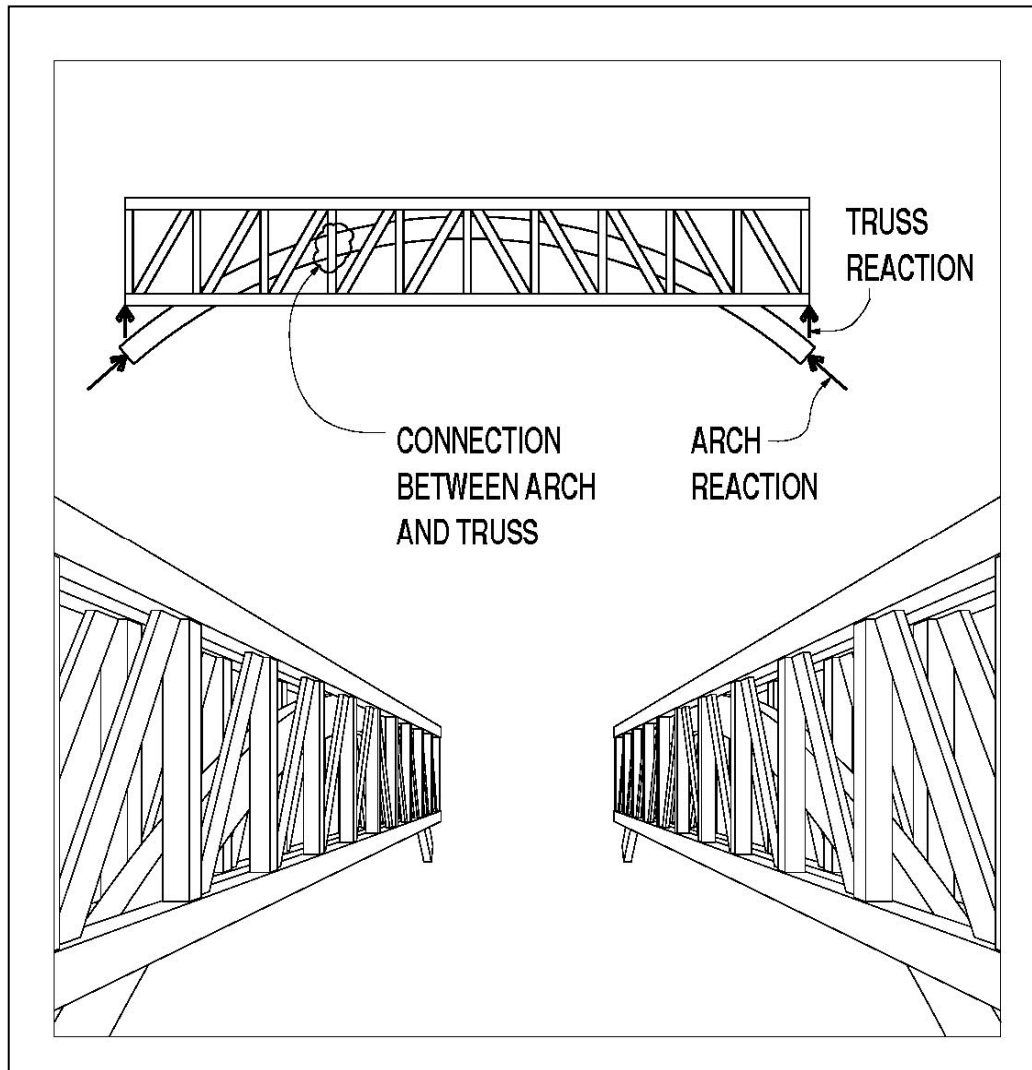

Figure 131. Load sharing between arch and superimposed truss.

Similarly, if the arch is tied and terminates at the bottom chord rather than bearing directly on the abutment, analysis of the structure must be performed carefully to accurately model the behavior of each element. Not only are both the truss and arch primary elements heavily loaded with shear and bending, in addition to the ever-present axial forces in each, but also the connections between the various components usually require the designer to consider myriad local geometry issues.

Overhead Bracing

Tie Beam to Truss Top Chord

Traditionally framed covered bridges usually contained overhead transverse tie beams at regular spacing along the truss. These beams held the spacing between the trusses, while serving as a basis for lateral buckling resistance for the top compression chords and overall bridge alignment at this level. The details at this connection vary, depending on the preferences of the builder and the situation, but they usually involve notching the undersides of the tie beams where they straddle the top chord. A very common weakness in detailing these notches was the insufficient relish in the tie beam, beyond the outer notch edge and running to the beam end. Large lateral forces in the upper level of the bridge can generate enough axial forces at this connection to shear off this relish, with outward top chord restraint suffering accordingly. Some original builders recognized this problem and would preemptively remove the relish

and replace it with a spiked block, loaded on the side grain. This detail is not as stiff as the intact relish, but it is not as brittle, either, and the mechanical connectors can be made as strong as the original wood shear capacity.

The original builders commonly used a direct mechanical connector to hold the tie beam down to the top chord and to keep that bottom dap engaged with the upper face of the top chord. This would also help prevent the tie beam (and roof) from lifting off with high wind forces and from the upward prying induced by transverse knee braces. Vertical bolts commonly were used, down through the tie beam and connected through a single-element top chord, or through transverse hardwood blocks beneath paired top chord elements. Figure 132 shows such a connection. This is a Town lattice truss rehabilitation. The end tie beam relish is noted, along with the bottom block and vertical bolt used to clamp the tie beam to the top chord.

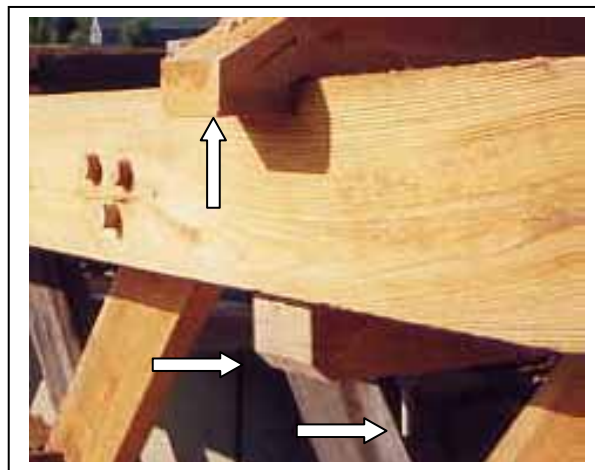

Figure 132. Tie beam to top chord connection.

Upper Lateral Connections

The connections between the upper lateral force-resisting components and their supporting tie beams almost always involved a mortise-and-tenon connection that allowed the builders to install the lateral braces and then tighten them in place through a pair of opposing wedges. The wedges were installed beyond the tenons on the laterals, in mortises that were cut both completely through the tie beams and further along the tie beams, leaving room for the wedge pairs. An interesting common feature of this connection is the deliberate vertical offset between the mortises for paired laterals in such a way that the laterals actually interfered with each other and had to be bowed vertically as they were installed into their mortises. This prebending meant that the counter lateral bracing was less likely to rattle or work loose and fall out. This offset would often be about 25 mm (1 inch), for a traditionally dimensioned single-lane bridge. Too much offset risked splitting the laterals in a level plane and at the stress concentrations caused by the notched tenon (see figure 133).

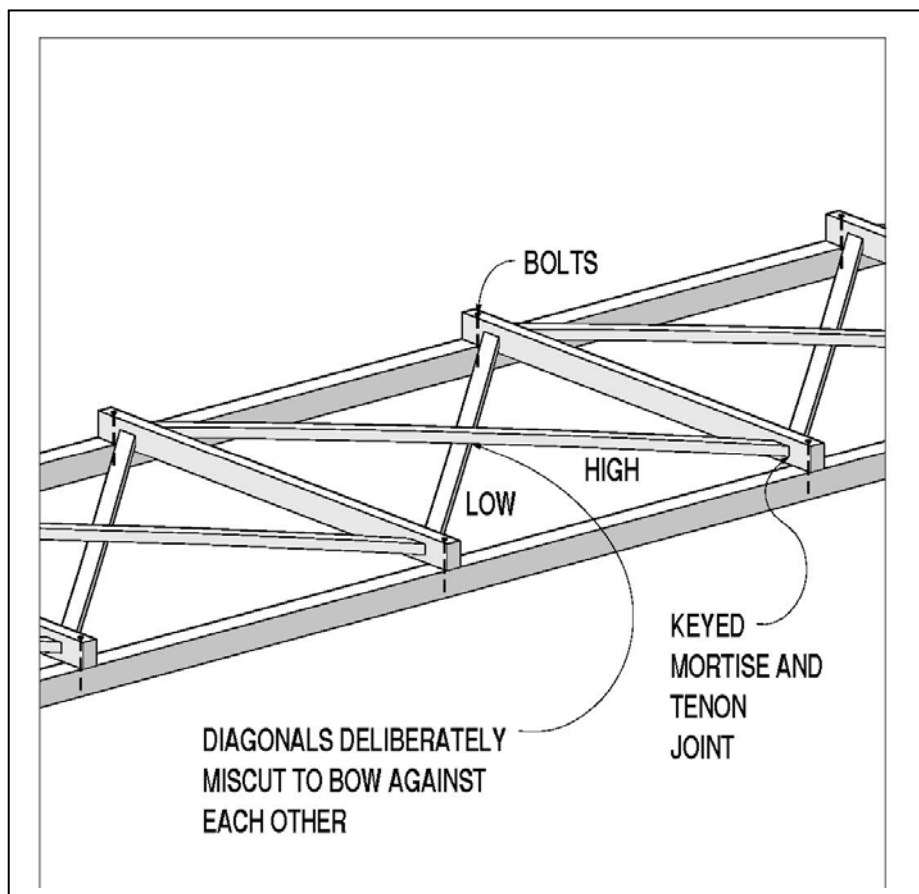

Figure 133. A set of upper braces.

The midpanel intersection between a pair of the lateral braces as they pass each other may be bolted or not, depending on the practice of the builder. A bolt can help lock the paired X braces together and may prevent one or both from falling out, should the wedges become loose or fall out. The hole for the bolt decreases the element's capacity, but only very slightly. While this decision is somewhat based on individual judgment, most designers would recommend installing a nominal galvanized bolt 19 mm (0.75 inch) at the bypassing lateral braces.

Knee Braces

The transverse knee brace connections vary tremendously. They were commonly made with pegged mortise and tenon to the underside of the transverse tie beams, which is still the preferred detail. For trusses with heavy timber vertical members at the panel points, the knee braces are usually connected here with another pegged mortise and tenon. The transverse knee braces in Town lattice trusses, which do not (usually) contain regular heavy timber vertical elements, generally are connected directly to the lattice members, preferably at an intersection between the two lattice layers where the receiving timber is twice as thick. These connections are notoriously weak, especially in tension, and often made only with toe-nailed spikes or lag screws. Rehabilitation projects often stiffen and strengthen these connections by substituting a horizontal bolt through the end of the knee and the lattice intersection. A few bridges contain a supplemental steel rod above and parallel to the knee brace, which provides more strength by engaging both knee braces in a tension-compression system, rather than the traditional compression-only system available with a toe-nailed knee brace. Even this connection detail is ultimately limited by the innate lack of significant strength or stiffness against out-of-plane point loads in the layered lattice planks. Some original Town lattice truss builders and some subsequent rebuilders have countered this intrinsic weakness in the Town lattice truss by adding some relatively heavy (double thickness) vertical planks along the lattice member and in-plane with the inner chords. These posts can provide better material for

knee brace mortises, while helping distribute the transverse lateral force more uniformly into the truss. Figure 134 shows an example of added verticals at tie beams in a Town lattice truss.

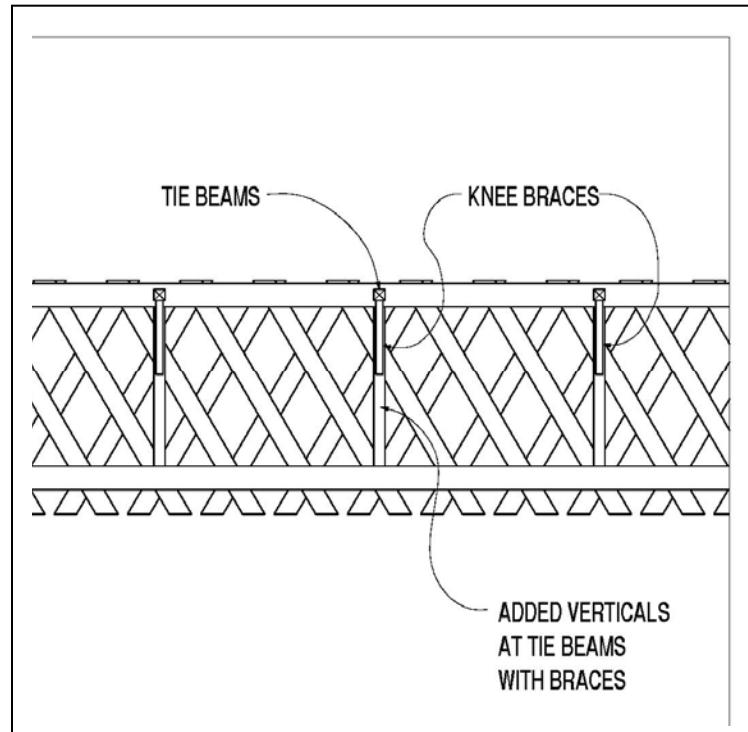
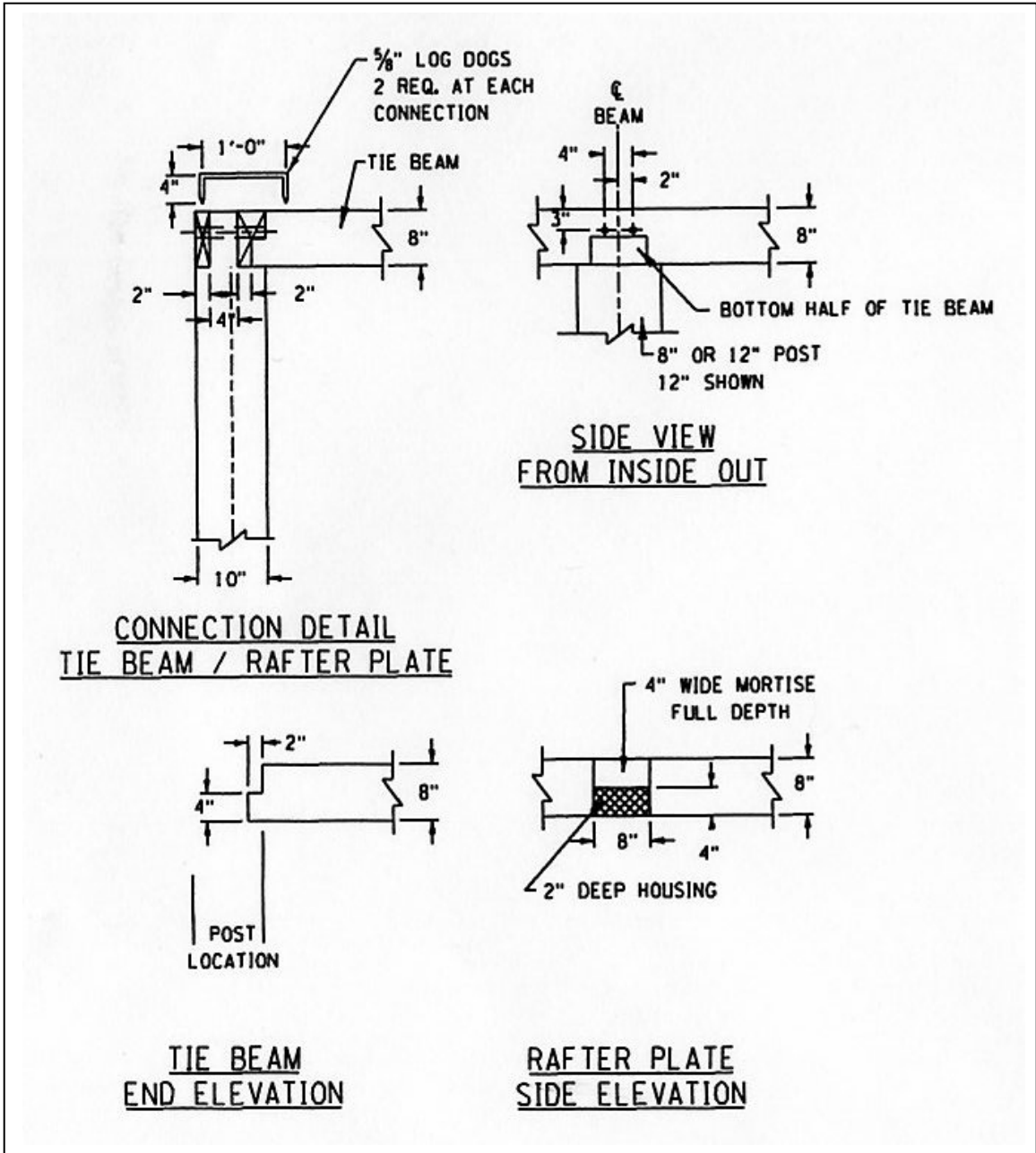

Figure 134. Added verticals at tie beams in Town lattice truss

Rafter Plates in Short Kingpost and Queenpost Trusses

Since kingpost and queenpost trusses do not normally contain top chord elements in their end panel(s), a rafter plate often was added to support the rafters over the final panel of the truss span. This secondary element may be made from heavy timber or assembled from smaller sections. It may either be continuous, running the full length of the bridge and above the truss top chord, or it may be connected only to the top chord (so that it exists solely in the truss end panel(s)). The rafter plate should be supported by the vertical posts and connected to the tie beams. These three-way connections may be in either separate planes or a common plane, although the latter is far more difficult to detail and to construct, and is often weaker. Figures 135-137 show such a tie beam to top chord connection. The photograph in figure 137 is of the joint that failed when a bridge collapsed due to heavy snow loading. It is immediately obvious that this joint has lost a lot of material from the elements due to the connection in one joint of three elements arranged at right angles to the others. The drawing details in figures 135 and 136 are of the replica bridge.



1 inch = 25.4 mm

Figure 135. Tie beam to top chord connection details, first diagram.

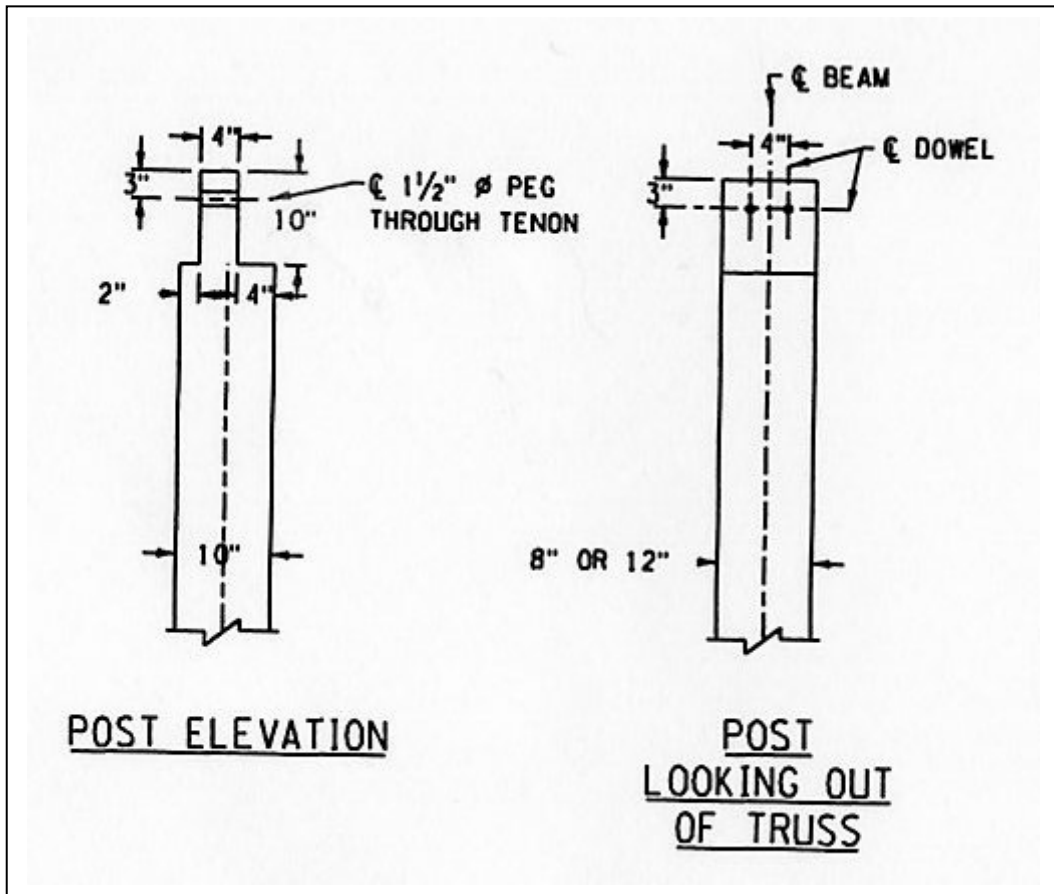

1 inch = 25.4 mm

Figure 136. Tie beam to top chord connection details, second diagram.



Figure 137. Tie beam to top chord connection details of failed joint.

Floor Connections

Decking to Stringers or Floor Beams

Deck planks typically are spiked down to the supporting stringers or floor beams. Practical installation considerations and almost inevitable eventual deterioration of these planks dictate that the spikes should be at least 10 mm (0.375 inch) in diameter and should be at least twice as long as the deck plank thickness. Two spikes per plank usually are used at each floor beam connection. Some installers use ring shanks, or similarly modified spikes, to help prevent loosening. The specifier and bridge owner should be aware of this detail, because although these withdrawal-resistant connectors can prevent premature spike head protrusions, replacing the deck planks without also replacing the stringers or floor beams is difficult. In fact, most deck spikes capable of holding the planks down under traffic loads are so secure that removing a plank involves grinding off the connector head and pulling off the plank over the remaining connector shank.

Glue-laminated, longitudinal deck panels, installed above the floor beams, often are connected with proprietary metal connectors that fit into a groove in the floor beams, and are lag screwed into the underside of the deck panels. This connector avoids a hole in the top surface of the deck panel that could allow road moisture to enter the panel material. Some bridge repairers use lag screws (typically countersunk into the top of the decking) in the tops of the floor beams or stringers. This detail also introduces the potential for roadway moisture in the panel material, but this installation allows the work to be performed from above. Some other repairers use bolts that pass completely through the deck and the supporting stringers or floor beams. The hole for this through-bolt can significantly reduce the flexural capacity in the supporting stringer or floor beam, however. Many believe that the potential for roadway moisture penetration below the head of the bolt or lag screw is minor, and therefore choose to work above the deck. The bolt head itself can be an issue, unless countersunk. Therefore, those who choose bolts often use dome head bolts that can be installed without countersinking, although a deck with exposed dome heads presents some serviceability issues. All these connection methods can perform satisfactorily, and cost about the same. The choice among them is based largely on judgment, as long as the various pros and cons are considered.

Stringers to Floor Beams

Longitudinal stringers, when used, are traditionally several panels long. The typical stringer is usually continuous over at least three floor beams. The individual stringers generally lap beyond the adjoining and continuing stringer. In this instance, the stringers are traditionally toe-nailed to the transverse floor beams with heavy spikes. If the stringers are efficient rectangular cross sections with depths greater than widths, diaphragms or blocking is prudent between the stringers as they cross the floor beams; this prevents the stringers from rolling.

Floor Beams to Trusses

As with most other connection details used in authentic covered bridges, this also lends itself to the builder's judgment. Some builders apparently believed that the floor weight alone was sufficient to hold the floor beams in place on the trusses, and that a mechanical connection was not needed between the two, because many bridges do not have a positive connection here. Other builders believed that a more positive connection was at least prudent and responsible, if not commonly necessary to resist any reasonable design loads, be they longitudinal from traffic-caused traction forces with braking or accelerating cars, or transverse forces caused by wind or stream flooding/debris/ice.

At minimum, there should be a connection that prevents the truss bottom chord from sliding out from under a floor beam. This can happen with heavy side impacts from ice floes or debris during floods.

Bridges with more than one bottom chord member often use a vertical bolt down through the floor beam, down through a gap between the chord members, and then through a hardwood block on the underside of the chord to clamp the floor beam to the chord.

For bridges with a single bottom chord element, a vertical bolt through the floor beam and chord occasionally is used. Besides the obvious substantial penalty to the bottom chord net section with the hole, the hole also may permit splash or rainwater to penetrate further and faster into the chord and to accelerate deterioration in the critical bottom chord timbers. Hence, from an engineering perspective, this is not a good connection detail.

Some have installed hardwood pintles (round pegs) on top of the bottom chord; these fit into matching holes in the bottom of the floor beams, achieving results similar to those with a metal rod. A recent example used pintles of 50-mm (2-inch) diameter and 100-mm (4-inch) length, 50 mm (2 inches) into both chord and floor beam. This complex connection helps reduce maintenance associated with the metal rod. A disadvantage of this connection is the inability to inspect the pintle and to examine its condition (or to even know it is there).

A common and simple way to prevent the bottom chord members from shifting along the floor beams is to install a transverse level metal rod connecting the two chords with nuts and washers on the outside of both chords. This rod can draw the chords tight against the floor deck and form a connection with a heavy floor system. This interconnection can ensure that the floor decking will act as a shear diaphragm and help resist transverse lateral loads while maintaining longitudinal alignment. These transverse rods can be positioned evenly along the span; often a quarter-point positioning is sufficient. A detailing issue with this rod is the protruding end of the rod, washer, and nut outside the chord. Because the siding is often attached to the outside chord surface or to a nailer, the nailer must be artificially widened for the siding to cover the ends of these rods. This widened nailer is preferred over simply cutting a hole in the siding that allows the rod extension to protrude through the siding. Although this type of detail was not common on original construction, it has become a popular retrofit in recent bridge rehabilitation projects and is recommended when other means are not employed.

Lower Lateral Bracing

When it exists under a bridge floor, the lower lateral bracing system typically is connected to the sides of the floor beams with mortises and tenons, if it was original to the bridge. A few bridges were built with a double X system, so that there is a mortise connection at the floor beam midspan. This mortise, however, can significantly reduce the flexural capacity of the floor beam and should be considered only as a last resort or if under pressure to match existing conditions.

Some replacement floor systems have installed lateral braces that are connected only with toe-nailed spikes or lag screws, because replacement floor systems often used larger and/or more floor beams. This meant that the original laterals had to be cut to fit, or they were replaced.

As indicated elsewhere in this manual, many covered bridge scholars believe that the lower lateral bracing system is unnecessary, at least for the majority of bridges that have floor decking directly above the floor beams. In this instance, the floor connection acts as a deep horizontal diaphragm, in combination with the bottom chords. These very deep beams, generated through diaphragm action in the floor decking, can be so much stiffer than any reasonable system of wedged lateral braces that they nullify the lateral load capacity contribution of the somewhat elaborate bracing system.

For those bridges that have decking on top of stringers that are on top of floor beams, however, a lower lateral bracing system is prudent to provide overall lateral load capacity. The extra plane of intervening elements allows more relative movement, in addition to the opportunity for the vertically positioned stringers to roll over, unless they are substantially restrained with blocking at the floor beams. In this case, the X bracing laterals would be installed beneath the stringers, to the sides of the floor beams.

Roofing and Siding

Rafter Connections

The connection between the rafters and the truss top chord or rafter plate usually consists of a notch in the rafter (termed a bird's mouth) where it rests on the top of the chord or rafter plate. Typically, the rafter is toe-nailed to the supporting member. Some earlier builders spaced the rafters farther apart than modern codes would allow and included a notch in the top of the top chord or rafter plate to allow an outward thrust-resisting bearing connection. This relieved the stress on the toenails, while being a more complicated joint that further reduced the chord net section. This connection practice is rarely followed today.

The peak of the rafter pairs is treated according to the builder's preference. The rafters may abut at a non-load-bearing ridgepole, and be individually toe-nailed to it. The rafters may simply abut directly to each other with toenails. Some very early builders included a half lap connection at the rafter peaks that may have been toe-nailed or even pegged.

Siding

Siding can be attached to the bridge with either nails or screws, depending on local preferences. However, it is important to avoid directly attaching the siding to the truss members, because that large contact area can easily retain moisture and lead to early deterioration in the crucial truss elements. A preferred detail uses nailing (or furring) strips on the outside of the truss element. These nailing strips should be shifted away from the truss element, with short spacers, to further minimize contact with the truss element (see figure 138).

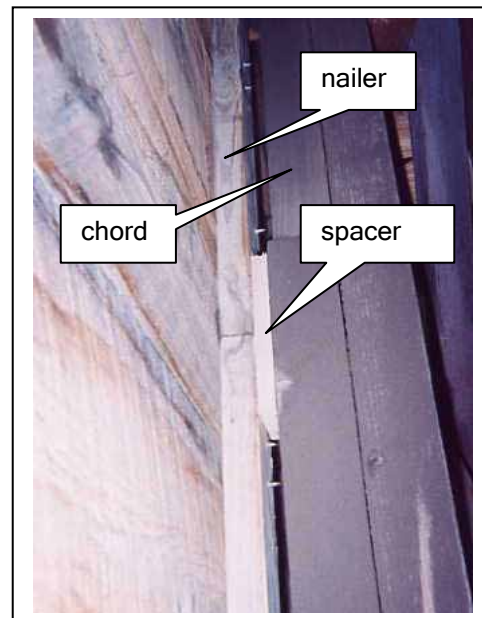

Figure 138. Siding nailers spaced away from truss elements.

SECTION 4. CARE OF EXISTING BRIDGES

- Chapter 15 Evaluating Existing Bridges
- Chapter 16 Repairing and Strengthening Existing Structures
- Chapter 17 Preserving Existing Covered Bridges
- Chapter 18 Historic Considerations with Existing Structures
- Chapter 19 Initial Preservative Treatment of Wood in Covered Bridges



Figure 139. Fitch's Bridge, Delaware County, NY.



Figure 140. Brown's River Bridge, Westford, VT.

Chapter 15. Evaluating Existing Bridges

This manual focuses on extant historic covered bridges. Therefore, critical topics deal with evaluating a given bridge from a number of perspectives, ranging from condition and anticipated remaining service life to reasonable load capacity and potential alternate uses. A careful physical examination of all bridge components by an experienced, knowledgeable, thorough, and careful professional, is often sufficient to identify the sources of potential structural distress, should they exist. Many individuals have the technical ability to analyze a relatively simple structure, but few can appreciate the complexities of a heavy timber truss connected with traditional methods. Experience often can guide inspectors to the critical elements in any given existing covered bridge. Therefore, attention to obtaining a careful field evaluation is an appropriate starting point for discussing bridge evaluation.

Field Examination and Inspection

A logical way to begin evaluating a structure would be to locate the original construction documents, as well as any subsequent rehabilitation contracts related to the structure, before visiting the bridge. Most extant historic covered bridges were built without significant plans, or plans that may have been used no longer exist, but this document research exercise is still appropriate. If plans are available, they may have been generated during a subsequent rehabilitation project, in which case, the extent of the documentation can range from minimal to thorough.

At a minimum, bridges that have been open to vehicular traffic within the past 20 years and that span more than 6.1 m (20 feet) should have been inspected as part of the routine, federally mandated bridge maintenance inspection program. Accordingly, bridge inspection records should be available to assist with the new field evaluation of the bridge. Because a bridge's condition can change quite dramatically and quickly, especially for timber structures that may be exposed to unsound roofing and/or siding, the latest inspection report may offer good background information, but may not be current. For structures that have been closed to traffic within the past 20 years, the last inspection record may be quite dated, because there is no Federal mandate to continue the inspection program for structures closed to traffic.

After all available information has been collected, the field evaluation may begin. Many references offer useful guidance about evaluating timber structures in general, and inspecting bridges in particular. (Refer to the *Manual for Condition Evaluation of Bridges*^[19] or *Timber Bridges—Design, Construction, Inspection, and Maintenance*.^[41]) This manual is not intended to duplicate such information. However, there are several specific issues that should be considered when inspecting an extant historic covered bridge.

In addition to identifying rotted or otherwise damaged materials, critical issues for inspecting covered bridges include:

- The horizontal and vertical alignment of the trusses.
- The degree to which the structure is out of square with respect to any of its axes.
- The condition of the tension splices in the lower chords.

Failing connections, not members, cause most problems with covered bridge trusses. A covered bridge's position and alignment can reveal a great deal about its condition and can help focus inspection efforts on specific connections.

Bridges often develop specific distortions as a result of deterioration in various components or connections. The deformations can be limited to the superstructure, or they can be related to external movements. The entire bridge can be shifting, with movement at an abutment or pier. This is fairly rare, but not unknown. A more likely cause of entire structure movement is deterioration in the supporting or bearing points. Most covered bridges were originally built with some form of sacrificial blocking to separate the lower chord members from the supporting stone or concrete foundation material. These bearing blocks were readily replaced, as contact with the collected debris at this location would accelerate their decay. Although they are designed and intended to be replaced fairly regularly, inspection often reveals that these components are rotted, often to an extent that threatens the chord members above with

moisture-related deterioration. Rotted lower chord ends is a very common cause for collapsing covered bridges.

Even an initial assessment of the bridge geometry can indicate the need to do a close inspection at the truss bearing areas. In many instances, the areas surrounding the ends of the bottom chords are surrounded with an accumulation of dirt and debris tracked into the bridge by the tires of passing vehicles, or washed in because of improper approach drainage. These areas should be cleaned at least annually to maintain good ventilation around the timber and eliminate the excess moisture exposure brought with this debris.

The most common distortions within the superstructure are sag and rack. A bridge that is out-of-square, when looking along the longitudinal axis, or down the lane, can be said to have racked. Usually, the transverse knee braces display evidence of this movement, particularly in those that are on the side with the now obtuse angle, or the ones that were loaded in tension as they tried to resist this racking. Failed knee braces are symptoms, not causes, of racked bridges. Something else is causing the movement, and the knee braces simply were not strong or stiff enough to resist the movement. Rack can be characterized further by whether the deck is level and the trusses are tipped, or whether the trusses are still plumb but the deck is sloped from side to side. Figure 141 provides an illustration of rack and distortion. Although it is more evident onsite, this two-span bridge was quite racked and distorted, especially over the pier. In this photograph, the distortion is most noticeable along the edge of the roof overhang.

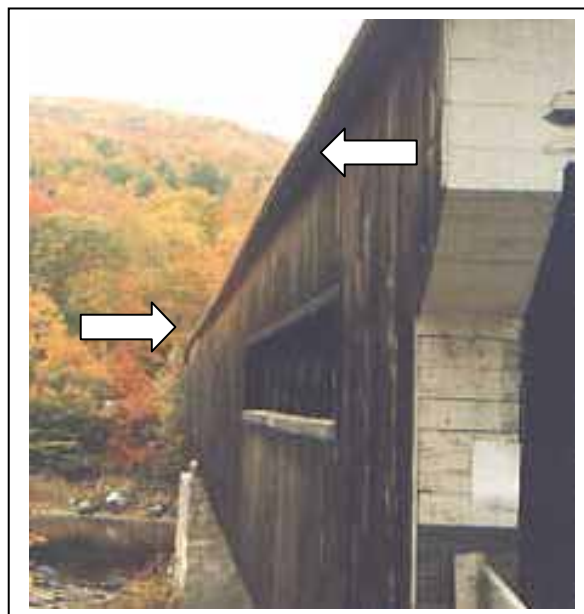

Figure 141. Racked two-span continuous bridge—West Dummerston, VT, before its recent rehabilitation.

Although the trusses in most surviving covered bridges are flat, some still have an appreciable vertical curvature. This camber in the truss is a measure of its out-of-flatness. A truss with a slight upward (positive) camber probably still is able to support its current loading without significant distress. However, this is not always the case. Over time, wood will creep under its own dead weight. When creep is sufficient, there is a noticeable sag in the truss. A sag (negative camber) in a truss may indicate structural distress, in at least some component or connection. A substantial sag could also lead to contact of the bottom chord of the bridge with the abutment back wall. An example of sag is presented in figure 142. Like the previous figure, it may be hard to discern, but the bottom chord of this long-span Burr arch bridge contained a sag in excess of 457 mm (18 inches). The bridge is scheduled for a major rehabilitation in the near future.

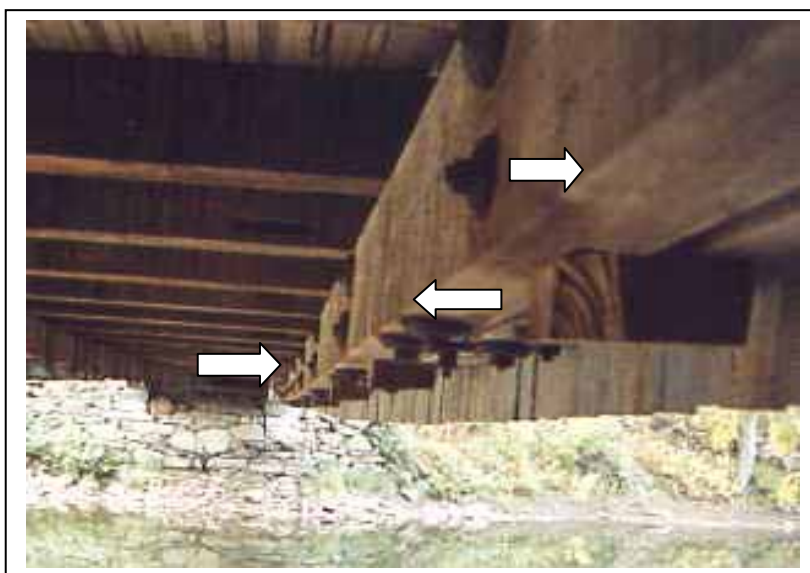

Figure 142. Example of sag—Station Bridge, Cambridge, VT, before rehabilitation.

Because the bridge was almost certainly installed plumb and square, it must have moved to a racked condition. Although it is possible, it is the exception that a bridge site may be exposed to regular and consistent prevailing winds that shift and tip the bridge. Rack almost always reflects internal distress. Settling at one side of a pier can initiate a modest tipping, which brings the bridge's dead load into position to further move the bridge sideways. With gravity and decay, this racking will continue until intervention stops it. Bridges that are racked and still have plumb trusses should be inspected for failure at the abutments or bearing blocks. This is especially true if the rack is worse near one end of the bridge.

If, on the other hand, the superstructure racking is reflected through a nonlevel deck, this may mean that one truss has settled more than the other. This unevenness is one way that failed truss connections manifest themselves. Several things could be causing only one truss to fail. Prevailing winds and wind-driven rains can cause nonuniform deterioration. Uneven loading could also cause the situation. For instance, the Wertz Mill Bridge in Pennsylvania has a two-lane configuration with a stop sign at one end and a gravel pit near the other. On a regular basis, the nearly 61-m (200-ft) span supports loaded gravel trucks waiting bumper to bumper to pass through the T intersection at the far end. On the return trip, these trucks are empty; therefore, the bridge has racked as a consequence of such unequal loading.

Uneven vertical position, however, is most likely a result of the natural distribution of wood's material properties, both in members and at connections. Seemingly identical trusses, submitted to virtually identical load histories, may still behave differently in the long run.

Among the many reasons that a heavy timber truss (or trusses) might sag under long-term loading, by far the most common is an inadequate tension splice. Because the tension members—and more specifically, the tension connections—are often the weak link in any heavy timber truss, a careful examination of these splices is essential. Large gaps at any connection justify a more thorough investigation. On the other hand, tight tension splices inspire greater confidence. Although there can be a large number of variations in the layout used in a tension splice, most contain some basic features (for more discussion, see chapter 14).

Large tensile forces require an extensive amount of bearing and/or shear area to transfer the forces from one tension chord member to the next. Therefore, in addition to considering the tightness of the joint, look for evidence of fiber crushing or overall member distortion as symptoms of tensile weakness or failure.

Figure 143 depicts a joint between bottom chord elements of a Town lattice truss. The large opening indicates a bridge in distress. In addition, the joint is rarely located at the center of the intersection of two lattices; the joints between chords are typically midway between lattice intersections.



Figure 143. A chord butt joint in trouble—Station Bridge in Northfield, VT.

The alignment of the trusses along their longitudinal axis and in a level plane indicates their load-carrying capacity, compared with the loads they have borne. These bows or sways (horizontal displacement or curvature in the trusses) can result from buckling in overstressed truss compression members. Misalignments in the truss chords (bows or kinks) can also indicate that the out-of-plane bracing of the compression members is inadequate. Overall bridge sway or bow is rarely initiated by transverse wind (or even high water) loads on the bridge sides. These distortions are almost always secondary symptoms of other problems; the bridge may have settled unevenly, initiating rack, which induced some sideways, for example.

Establishing the bridge's alignment is relatively straightforward in construction surveying. The vertical alignment is measured with a level. The first thing to determine is the overall vertical position. Most bridges span between level abutments and piers, but this is not always the case. In cases where covered bridges span both far enough and between banks that are of sufficiently different elevations, the builders placed the superstructure on a slope. In these cases, the camber or sag must be plotted relative to a sloped line. The horizontal alignment should be measured at both deck level and at the eave line level. In both horizontal and vertical alignment measurements, the position is established relative to consistent points in the superstructure. Commonly, the deck and roof beam centerlines are used to establish rack and sway. The top surfaces of the bottom chords are fairly convenient and consistent spots to use for the vertical sag or camber measurements. In trusses with panel points, the truss verticals are logical places to take both measurements. In Town lattice trusses, almost any reasonable and evenly spaced transverse cross section will serve; a common use would be at each roof beam. There are many ways to represent the deflections that will be of use to analysts and those responsible for assessing a bridge's condition. Both the original data and these plotted deflections should be carefully saved, because they could prove invaluable to subsequent investigators who might be trying to determine whether a span has moved. Leaving discreet marks on the members where the measurements were taken, and taking thorough and careful field notes, could help subsequent measurements be more meaningfully compared with earlier ones.

It can be very difficult to inspect for deterioration in individual bridge components. This is especially true for members that are in close proximity to sister components. The mating surfaces at connections between adjoining members can be deteriorated to the point of leaving the components with little capacity while exhibiting little outward evidence of this distress.

Probes and moisture meters are vital to a thorough member and connection inspection. The moisture meter can identify areas of high moisture where deterioration is more likely to begin. Deteriorated areas can be investigated with an increment borer to identify the extent of internal decay. However, it can be extremely difficult to ensure that all areas of deterioration have been found, before any rehabilitation involving bridge disassembly.

Wood Species Identification

As mentioned earlier, determining the wood species of various bridge components can be vital when evaluating the bridge. Because very few investigators are sufficiently trained and experienced to identify wood species in situ, small specimens (coupons) of timber can be removed from critical bridge elements for remote identification by a trained specialist working in an equipped laboratory. The specimen can be quite small (about the size of a short pencil) and still provide sufficient material for the specialist. The cost to examine a specimen generally is not significant.

Timber Grading

As with species identification, few individuals are trained to identify the quality grading for any particular existing component, be it Dense Select Structural or not as good as Number 2. However, lumber grading organizations can provide individuals who are qualified to conduct a field grading examination of an existing structure. With available access for tactile and visual inspection of the various components (given physical proximity and removal of siding at critical locations), an experienced lumber grader can offer guidance on grading the bridge members in 1-2 days. The cost for these in situ grading services may be a reasonable daily professional fee plus travel.

Because portions of the surfaces of some components are likely to be obscured from view by adjacent members, the grader will have to limit the quality assessment to that based on surface areas that are visible. This often results in a quality identification of only what a given member is not; for example, "This member does not qualify as a "Select Structural," or "This member is no better than a Number 1." Hence, the professional assessment of timber quality, while valuable, can still leave some gaps in the physical assessment of the bridge's condition. The engineer, therefore, must determine the appropriate characterization of that phase of the work based on the input provided by the professional grader, but subject to the above noted limitations.

Individual Member Assessment Through Strength Ratio Concepts

Lumber grading rules divide timbers into a few discreet categories with their attendant allowable stresses. It is theoretically possible to establish a reasonable and timber-specific allowable level for each stress type by using basic methods to establish allowable stresses. To derive a more thorough assessment of the condition of various components in a covered bridge, beyond species identification and grading, one can conduct a refined examination of the various member elements based on concepts identified as strength ratio. "Material Properties/Allowable Stresses" in chapter 13 contained a listing of the ASTM specifications that aim to establish the allowable stresses for timber, based on various physical features of a given timber (e.g., knot size and distribution, slope of grain, and growth ring spacing). Specifically, ASTM D 245, "Standard Practices for Establishing Structural Grades and Related Allowable Properties for Visually Graded Lumber," contains the technical protocols for conducting such a field examination. This work requires special training as a wood scientist, as well as experience with timber in general. The complete field evaluation of all the members in a covered bridge could take several days or weeks, with commensurate costs. Such an examination is still restricted to visible portions of the structural components. Further, the results available even with this elaborate procedure are limited by the fact that the procedure is based on the standardized use of the 95 percent exclusion rule, as discussed in chapter 13.

Analytical Evaluations for Vehicle Capacities (Load Rating)

Chapters 11 and 12 contained discussions aimed at evaluating the forces on, and stresses in, the various covered bridge components. Comparing the design capacity of the structural elements to the design forces imposed on them is vital in establishing the vehicle weight or pedestrian density that can safely cross the structure. As noted elsewhere in this manual, this comparison effort often yields results that indicate a theoretical weakness with the bridge that could be contrary to the clear historic evidence of apparent safe use by unrestricted vehicles.

The AASHTO publication, *Manual for Condition Evaluation of Bridges*, contains provisions to help analysts determine the safe load that can cross a structure—a process termed rating a bridge.^[18] In simplified terms, a given structural element's rating is the ratio between the element's net live load capacity and the force imposed in that component by a rating vehicle. As long as the given element has a capacity greater than that induced by dead load alone, it can be said to have a reserve available for live load. In a desired situation, the element would have sufficient capacity to support the forces induced by both dead loads and the full weight of the desired vehicle weight.

As an example, suppose a given bridge component has an axial capacity of 13,630 kg (30,000 pounds). Further assume that the weight of the structure induces an axial force in the same element equal to 9,080 kg (20,000 pounds). Finally, assume that an H20 design vehicle would cause a 9,080-kg (20,000-pound) axial force in the element. In this case, the total force from both dead load and desired design vehicle is 18,160 kg (40,000 pounds), which exceeds the capacity of the element. However, the element does have a capacity reserve for live load equal to the 13,630-kg (30,000-pound) capacity minus the 9,080-kg (20,000-pound) dead load force, or 4,540 kg (10,000 pounds). This means that the member could safely support a vehicle weighing half as much as a full-weight design vehicle, or 9,080 kg (20,000 pounds). In another way of representing this calculation, the element would have a rating factor equal to $(30,000 - 20,000)/20,000 = 0.5$. Applying this to the 18,160-kg (40,000-pound) H20 design vehicle gives an allowable live load of 9,080 kg (20,000 pounds), or H10.

The AASHTO specifications further provide for two conditions related to evaluating existing structures analytically. The first measure uses the same stress level as that used for design conditions as a measure of the capacity of the structure that should be safe for everyday traffic—the inventory condition. The second capacity measure uses a higher stress level—one that is still safe, but intended only as an upset limit for the rare and occasional use by heavier vehicles. This is the operating condition.

To continue the previous example, assuming that the capacity of the element previously cited was at the inventory stress level, then a vehicle weighing only up to 0.5 times that of an H20 vehicle (i.e., an H10 vehicle), could safely cross the structure repeatedly. Next, assume that the operating stress level for the given example element is such that the operating capacity of the element is 18,160 kg (40,000 pounds). (Note that the relationship between operating and inventory stresses is a function of various parameters, but is typically assumed to be no more than 1.33 more for timber bridges.) Then the operating rating factor of the element is $(40,000 - 20,000)/20,000 = 1.0$. This indicates that, while the element can safely support the forces induced by the full weight of only a H10 design vehicle repeatedly, the element should still safely support the weight of a heavier vehicle (as heavy as an H20 vehicle) on an occasional basis.

Determining the rating for the overall structure is controlled and established by the lowest rated element. This means that all load-supporting components must be evaluated to determine the critical capacity for the entire bridge.

A key decision in establishing a bridge's capacity relates to the significant difference between inventory and operating ratings. When structures cannot safely support full design vehicle loading using the inventory rating levels, then a weight restriction may be imposed on the structure. Determining the appropriate weight restriction for the structure usually culminates in installing a regulatory sign (e.g., Maximum Weight 10 Tons, Single Truck Only, Passenger Cars Only). Some highway agencies base their load-capacity posting policies directly on the inventory stress level, some base it on the operating stress level, while still others use some function between the two levels. If the alternate route is not excessive or onerous, some bridge owners will post a lower, intentionally conservative load limit to protect the bridge.

Because of the common difficulties encountered in documenting higher safe load capacities for covered bridges when based on current specifications, some have suggested using the upper stress level (the operating level) in posting load capacities for these historic bridges. The decision to use operating levels as posted limits should be made carefully. While it may be difficult to adopt this protocol based on the intent of the specifications, it is nonetheless a means to document a somewhat higher capacity while still keeping with the apparent (if difficult to determine by calculations) reserve strength that many covered bridges demonstrate.

The preceding discussion was prepared assuming that the covered bridge in question appears to have more load capacity than an initial and theoretical rating evaluation would indicate. If there is any evidence of particular structural distress in the structure, then there should be no reason to look for ways to deliberately inflate its safe load capacity. This process must be performed by competent engineers, with experience in both rating bridges and evaluating timber structures.

Analytical Evaluation for Pedestrian Density Capacities

Evaluating the relative safety of using a structure solely for pedestrians is closely related to rating structures for their safe vehicular load capacity (recall that chapter 11 discussed pedestrian loading).

The AASHTO bridge specifications contain guidance on assumed design loading from pedestrians as a function of the bridge deck area that might be loaded. Indeed, closely spaced pedestrian loads, such as might develop on a bridge during a special event, can represent a sizeable load on a structure, even more than that from light vehicles. However, if there is no reliable or credible history of such event on the bridge, then the full pedestrian loading contained in the AASHTO specifications is not necessary.

Similar to the process used to determine the reserve capacity available for vehicular loading, one can determine the reserve capacity for pedestrian loading and then compare that available capacity with the likelihood of that many people congregating on the bridge at any one time. If the available capacity seems small, then it is appropriate to be conservative. Yet, often a structure will have a safe reserve capacity for hundreds of pedestrians in a location where the structure may only rarely experience more than a few people at one time. Evaluate pedestrian loading realistically. Signs can be prominently displayed, with warnings about limitations on the numbers of people allowed to safely occupy the span at the same time.

Load Testing

Much has been written about the difficulties in accurately analyzing the load capacity for any given structure. An alternative approach, a nondestructive field load test, is occasionally used.

When a structure apparently has higher load capacity than analysis indicates, then a careful program involving incrementally loading the structure can be undertaken. Span deflections and member or connection strains can be measured and compared with predicted values. Comparing measurements at incremental loading can indicate whether the structure is behaving in an apparently elastic mode or, rather, if inelastic behavior is being induced. Elastic behavior implies that the stress levels within the structure may be within acceptable limits, and the members are not permanently deformed after the load is removed. Inelastic behavior implies that the loading is too high, resulting in permanent deformation, or otherwise is unsafe for the structure.

Nondestructive load testing procedures for metal structures are widely accepted as safe and reliable. Strain measurements are repeatable in metal structures, lending support for conclusions. The AASHTO *Manual for Condition Evaluation of Bridges* term for comparing field strain-gauge information to that anticipated with linear elastic behavior analysis is “diagnostic load testing.”^[18]

Proof testing establishes a safe load capacity, based on incrementally loading a bridge to levels based in analytically estimated capacities. If the target load can be attained without apparent distress to the structure, then that capacity is identified as a proof load. If structural distress is encountered at loads below the target load, then the capacity is reduced accordingly. The National Cooperative Highway

Research Program (NCHRP) has developed an entire manual that explains proof and diagnostic testing, the *Manual for Bridge Rating through Load Testing*.^[20]

Timber structures, however, tend to be far less homogenous than metal structures, meaning that strain measurements are much less reproducible and reliable due to the larger discontinuities in timber. Further, it is much more difficult to determine if a timber structure is behaving within the elastic range or inelastic range. Because the primary structural components of interest in establishing covered bridge capacity are the timber trusses, the deflections in a typical timber truss may be only a small fraction of an inch, even under a 20-ton vehicle load. Furthermore, the time-dependent material properties found in wood can obscure the relative elasticity of a given load level. Small variations in the ability to measure the deflection can greatly influence the interpretation of the test results.

For these reasons, the analyst should be very careful about relying on nondestructive load testing results as a primary determinate in establishing the load capacity of a covered bridge. However, using field measurements to augment information generated by analytical evaluations can be very instructive. Using sophisticated analytical evaluations of timber structures benefits from independent means to verify the predicted behavior. For instance, given a refined computer analysis of a structure, comparing predicted and field measured deflection behavior and strain behavior can offer additional confidence in the computer simulation, or can indicate the need to examine unexpected results. In this way, load testing is very helpful as another tool, even without relying on it entirely for establishing the capacity of the structure. Figures 144 and 145 show a load test of a Town lattice truss bridge for deflection measurements used as a check against such a computer simulation. Figure 144 shows the two trucks used as known loads. Figure 145 shows several dozen dial gauges used beneath the structure to measure the response of various locations under the imposition of known weight vehicles positioned at specific locations along the bridge.



Figure 144. Field tests for deflection measurement comparison against computer prediction—Brown Bridge, Shrewsbury, VT.



Figure 145. Dial gauges used to measure the load response.

Appendix A contains an article, “Those Intriguing Town Lattice Timber Trusses,” which discusses a recent load test using strain transducers in an historic covered bridge.

Destructive Testing of Components Removed From Bridges

Over the past several years, there have been various attempts to examine the behavior of the more critical components in covered bridges, through both nondestructive and destructive means, including:

- Wooden peg tests, aimed at determining allowable forces in the traditional connectors used extensively in Town lattice trusses.
- Tensile tests of representative lattice elements, aimed at determining whether old-growth timbers from an extant covered bridge may yield higher test capacities than predicted with current allowable stress levels.
- Tests on the methods used to splice lattice truss chord elements, aimed at retaining more original fabric when repairing extant bridges.
- Tests on floor beams and floor systems representative of those found in typical covered bridges.

There is little information in contemporary literature about the shear strength of the wooden pegs used as connectors in Town lattice trusses. The wooden peg tests mentioned above were pilot tests of the various strength parameters found in the typical, full-size peg connections. The test specimens used the oak pegs and spruce timbers and single and triple connector configurations found in the actual trusses. For the specimens tested and the materials used, the approximate double shear strength of a single 44-mm (1.75-inch) diameter peg was established to be about 681 kg (1,500 pounds). This work provided a measure of reassurance about the shear stresses determined analytically, using a sophisticated three-dimensional finite element modeling of the supporting Town lattice trusses.

Figure 146 shows a three-element test specimen used to test direct shear in a three-peg connection. The timber planks were typically sized spruce elements used in many bridges. The pegs were 44-mm (1.75-inch) diameter rounds typical of trunnels used in Town lattice trusses. The test involved measuring vertical load resistance versus displacement, and this image was taken following complete failure of the connection, as indicated by the trunnel that has failed in bending.

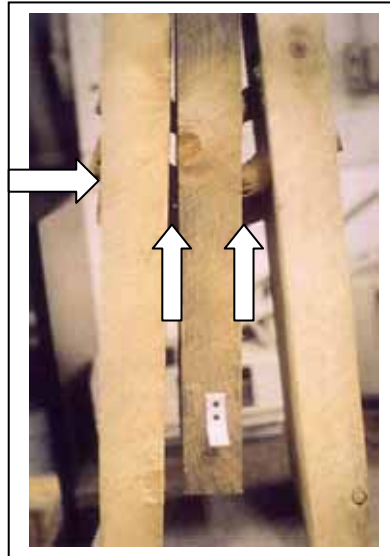

Figure 146. Three-element test specimen.

Load tests were also performed on lattice elements removed from two extant covered bridges that were scheduled for followup extensive rehabilitation. The tests involved using eight lattice elements, approximately 75 by 300 mm (3 by 12 inches), and 6.1 m (20 ft) long. Initially, the full-size lattice members were tested to destruction, following the requirements of ASTM D198. Remnants of the failed elements were then prepared for small-scale testing, in accordance with the requirements of ASTM D143 tests. While the tests were informative, the lack of statistical support due to the limited number of test specimens failed to provide clearly definitive answers. However, the work led to the hypothesis of considering a reduced exclusion percentage in manipulating timber material's allowable stress properties. Research is pending to test further that hypothesis.



Figure 147. Tensile tests on lattice elements.

Chapter 16. Repairing and Strengthening Existing Structures

Repairing and/or strengthening an existing historic covered bridge often can be more challenging than designing a new one. The reasons include:

- Constraints associated with the geometry and alignment of the existing structure.
- Restrictions related to historic preservation protocols.
- Difficulties associated with matching the strength and/or flexibility of the existing structure.
- Complications of incorporating public input, which can be vociferous for these special structures.
- Economics and uncertainties associated with any rehabilitation or restoration project (see “The Advisory Council on Historic Preservation” in chapter 18 for definitions of the nuances between the two).

When repairing historic masonry, one problem is finding replacement mortar as soft as the original. Hard replacement mortar will do more harm than good by overstressing the stones when it expands. An analogous problem occurs when repairing heavy timber trusses. Replacing existing members with new, stiffer ones can change the structure’s behavior under load by redistributing the stresses. Even identical replacement members can behave differently than the members they replace, depending on how they are fit and how the span is supported while the repairs are being made. The structural consequences of these load path shifts can be serious.

The following sections of this chapter present a variety of methods that have been used to repair and strengthen covered bridges. Many measures have been in use for a long time; others are relatively new. It is important to recognize that increasing attention to meeting the requirements of the Secretary of Interior’s standards for historic preservation prevent some of these measures from being pursued now (see Chapter 18 for a more thorough discussion and reference citation). Some actions may have been popular at different times and in specific areas (due to the preference of certain builders and engineers), but were poor choices for a variety of reasons, as discussed here. A summary of practices to follow and things to avoid is presented at the end of this chapter.

Repair of Trusses

The most basic way to repair a covered bridge is to replace deteriorated components in-kind. This entails using timbers of similar size and connection detail as the replaced members. At times, simply substituting a stronger wood species may provide additional strength and service life. The deteriorated component may either be completely replaced or partially replaced. Figure 148 provides an example of replacement of a deteriorated truss element (the first, light-colored vertical post). The next two posts have been repaired by adding new bottom elements adjacent to existing elements that were broken at the bottom.

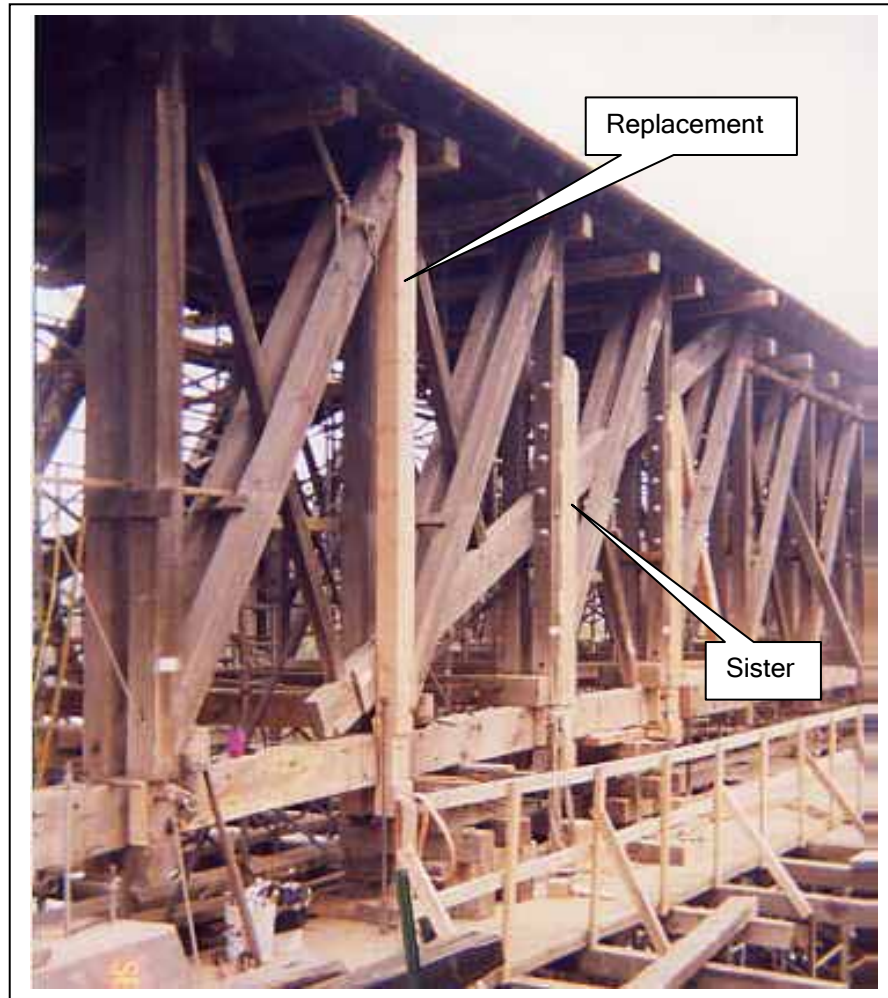

Figure 148. Replacement versus sister elements in Long truss–Downsville Bridge, Delaware County, NY, during its major rehabilitation in 1999.

One important issue related to member repairs (or replacement) is identifying appropriate means for relieving the forces in the replaced element before its removal. The structure may have to be completely shored on false work to allow removing the component, or temporary bracing may be used to loosen it. A member should not be removed while it is under load. It is virtually impossible to install the replacement element with that original loading in it, which means that the load distribution in the repaired structure will be different.

If a partial replacement is installed, the connections of the new component must be appropriate. There may be limited space for the new midlength connections. Although it is possible to design, detail, and install a proper repair for a given weakness or problem, repairs often are not well done and do more harm than good. Good repairs require precise work in each step, in accordance with the following guidelines:

Design: The repair must have adequate design capacity for the given loading and must maintain the intended function of the component, while matching the desired fixity of the connections. The required shoring and repairing sequence may be the designer's responsibility.

Detailing: The repair must be detailed so that the work is feasible under field conditions. It must also match the original design. The reasoning behind the detailing and design must be understood by those performing the repair in the field.

Installation: The workmanship must be careful and precise for the repaired member or connection to perform as intended. The workmanship in cutting must be high-quality. Shoring and installation must follow design intents. Interaction between the designer and the repair contractor must be constant and convenient, and adjustments must be made for any problems discovered as the work progresses.

The last section of this chapter references three case studies presented in the appendices that discuss specific bridge rehabilitation projects. Each article provides examples of various means of repairs and strengthening (strengthening is discussed in more depth in the following section). There are a number of other specific ways to repair truss elements, as discussed below.

Town lattice trusses often contain web elements that have become split at their bottoms. The split may be the result of high stress with a corresponding horizontal shear split from the truss forces. The split may be the result of ice impact. In addition, the elements may contain an area of rot from poor weather protection; this is most commonly discovered between the mating surfaces of a lattice member against the adjacent elements during reconstruction projects. When the deterioration of the element is extensive enough to be addressed, there are two viable actions: the entire element may be removed and replaced in-kind, or a supplemental element may be installed immediately adjacent to the damaged element. In the jargon of Town lattice trusses, the elements are termed sisters. The sister is rarely full-length; it is often only about half the original's height.

Figure 149 provides an example of a sistered repair of damaged Town lattice elements. The shorter ones are sisters.



Figure 149. Sister elements in Town lattice—Silk Road Bridge, Bennington, VT.

Figure 150 depicts an example of repair of a damaged end post with a sistered element. In this case, the sister element is connected with timber shear blocks and some bolts. The original diagonal was cut short to allow it to bear on the new sister element along the original line of the diagonal, thus keeping the axial action unchanged. Figure 151 provides an example of a partial replacement of a damaged element. The original element is half-lapped to the new and outside splice timbers that help hold the splice tight. Square shear keys project out from the center of the lap splice.

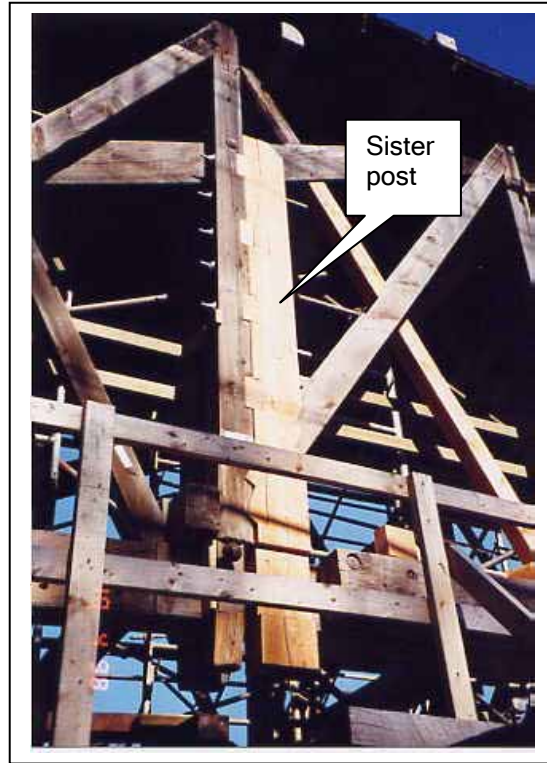

Figure 150. Sistered post repair in Long truss–Downsville Bridge, Delaware County, NY, during its major rehabilitation in 1999.



Figure 151. Partial post replacement in multiple kingpost truss—Union Village Bridge, VT.

Common Ways to Strengthen Covered Bridge Trusses

One common way to strengthen a covered bridge involves reinforcing existing timber components with new ones. The new members must be connected to the existing structure to allow both the new and existing components to share the loading. An example would be installing extra chord members on an existing Town lattice truss. This would best be done with the entire structure supported on false work to relieve the load in the trusses before adding the new material. Replacing the existing pegs with longer ones would be necessary to accommodate the additional outside chord elements. The holes in the new outside chord elements would have to be drilled using the existing holes as a pattern. This requires placing the new material on one side at a time, followed by drilling holes from the opposite side of the chord.

Related to this, extra chord elements can be added to an existing Town lattice truss, as shown in Figure 152. This relatively long single span was modified by adding a pier. The extra chord elements were intended to strengthen the truss over the pier with its new condition of negative moment.

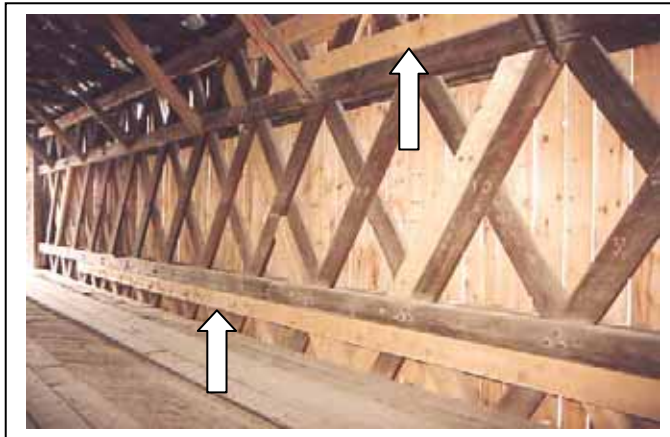

Figure 152. Extra chord elements added to an existing Town lattice truss—Cedar Swamp Bridge, between Salisbury and Cornwall, VT.

Another way to strengthen a covered bridge involves installing supplemental steel rods, cables, or rolled shapes to an existing member. An example would be adding post-tensioning to an overstressed lower chord members or tension splice. Figure 153 presents an example of metal elements added to an existing bottom chord. In this case, the truss is actually a tied arch. A pair of high-strength, post-tensioning rods installed below and parallel to the bottom chord can be seen on close inspection. The designer should carefully consider the differential thermal characteristics between metal and wood.

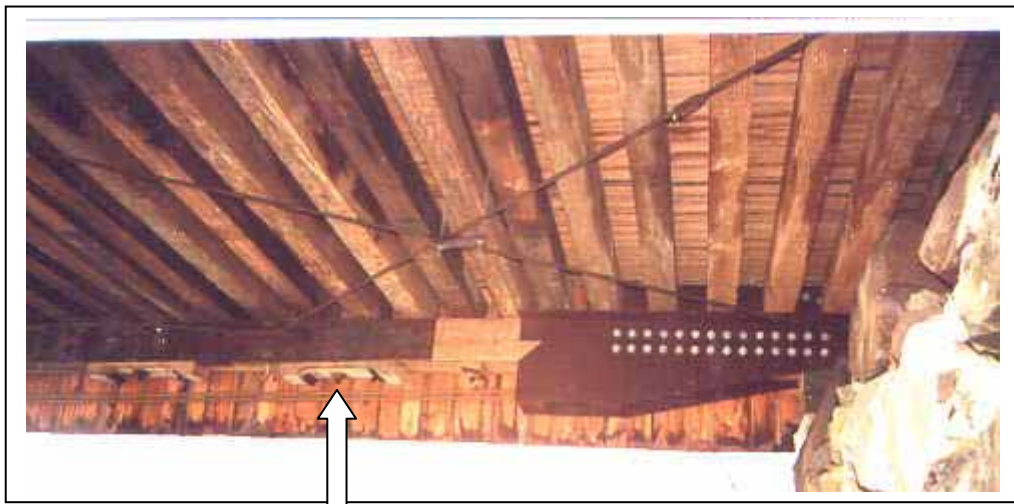

Figure 153. Metal elements added to an existing bottom chord—Lincoln Bridge, Woodstock, VT.

A classic way to strengthen the original trusses in covered bridges has been to install a timber arch (or arches) adjacent to the original truss. Theodore Burr's system, patented in the early 1800s, incorporates just such an arch with a truss. The Burr arch combination was very popular and continues to support more covered bridges than any other configuration, as mentioned in chapter 2. Since then, for structural reasons, arches have been retrofitted to virtually every timber truss type. Figure 154 depicts an example of an arch element added to a Town lattice structure. The deformations in the arch demonstrate that it was unable to support all the loads that were transferred to it. The bridge is now closed to vehicular traffic.



Figure 154. An arch element added to a Town lattice structure—Scott Bridge, Townshend, VT.

Analytically establishing the degree of load sharing between the juxtaposed truss and arch has always been challenging. There seems never to have been any consensus on the load-bearing intent behind Burr's original structural form combination. Some analysts have asserted that the trusses are meant to carry the dead load, while the arches are meant to carry the live load. Others disagree, saying that the arch is potentially stiff enough to carry virtually all loads, and the truss simply distributes point loadings into the more arch-friendly distributed configuration. The many variables that cause further confusion between theoretical and actual behaviors include:

- Yielding at arch and truss supports.
- Fabrication tolerances in the arch and truss connections.
- Local buckling in the arch.
- Relative stiffness in the connections between arch and truss.

An example of such deliberations is depicted in figure 155. A single bolt connects these single-piece arch segments to the truss post. Such connections are commonly distorted, indicating a connection that is inadequate to carry the loads imposed on it. The addition of an arch to an existing truss must address the real forces imposed on the connection.



Figure 155. A single bolt connects these single-piece arch segments to the truss post—Wehr Bridge, Lehigh County, PA.

Interestingly, the arch often is not actually large enough to support a significant portion of any applied loads. In other cases, however, the arch supports most of both the live and dead loads. Analysts and designers should be cautious and conservative in evaluating load paths and sharing in any such hybrid structure, whether designing a new one or retrofitting and repairing an existing one.

Less Authentic Repair and Strengthening of Trusses

Due in part to the complexities encountered when reinforcing original covered bridges to carry current loads, the entire original floor system commonly is replaced with an independent, load-carrying structure. This new enclosed bridge could be longitudinal steel beams with a concrete or timber floor, which act independently (or even, in some extreme examples, also support the original trusses) from the covered bridge. While some argue that this approach retains, rather than destroys, the original covered bridge, others note that the resulting bridge has been completely gutted. An objective concern regarding this rather drastic repair method is that future safety inspections of the structure (mandated by Federal law) will necessarily focus on the new floor (which is supporting the vehicle loads), while the existing and original trusses and roof structure may be ignored. Without even the basic, minimum maintenance repairs, the original wooden shell may deteriorate rapidly, even though it is carrying only minor loading.

Frequently, engineers familiar with steel trusses attempt to repair timber trusses using details similar to the ones they know from their past work. Classic examples of this unfortunate transference to covered bridges include:

- Using bolted heel plates at the bearing ends of queenpost trusses (see figure 156). The steel plates were intended to reinforce the original timber connection at the heel joint of a queenpost truss. However, the large area of steel/wood interface often leads to condensation and rot in the timber behind the plate, which is impossible to inspect without removing the added steel plates.
- Replacing the bottom ends of lattice members with bolted lap connections (see figure 157). The lower tails of these lattice members in a Town lattice were damaged by ice floes. Rather than replace the entire lattice element, the lower portion was removed and a new one installed. This splice between

the new and old elements relies on bolts that have a substantially smaller capacity than that provided by the original timber element. A close examination of the photograph shows relatively large gaps between the ends of the lattice elements, behind and at the center of the outside timber splice timber, indicating early signs of failure of the connection.

- Using steel bolts in Town lattice bottom chord replacements, as shown in figure 158, rather than using traditional hardwood pegs. Although more testing with wooden pegs is warranted because there is little in the literature or specifications about them, using steel bolts is unnecessary and extremely expensive. Large diameter bolts can also be so stiff, relative to the timbers connected, that they fail to share loads at all uniformly. This uneven load sharing has led to several dramatic failures due to progressive collapse. Fieldwork realities also make it extremely unlikely that the bolt holes will be accurate enough to allow uniform load sharing among multiple heavy and overly stiff bolts.

Often, these repairs are a poor substitute for compatible repairs installed by skilled craftsmen. In many instances, these repairs can even further weaken the structure. The ill-advised repair may well reduce the net section in critical tension members, thereby further reducing capacity.



Figure 156. Steel plates at heel connection of queenpost truss—Power House Bridge, Johnson, VT, before its collapse in 2001.

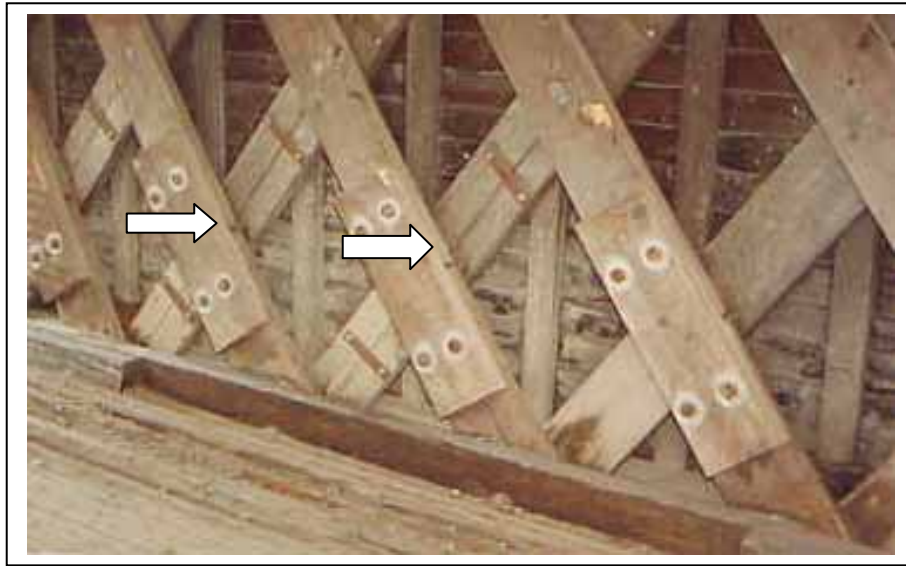

Figure 157. Spliced lattice tail replacements—River Road Bridge, Troy, VT.

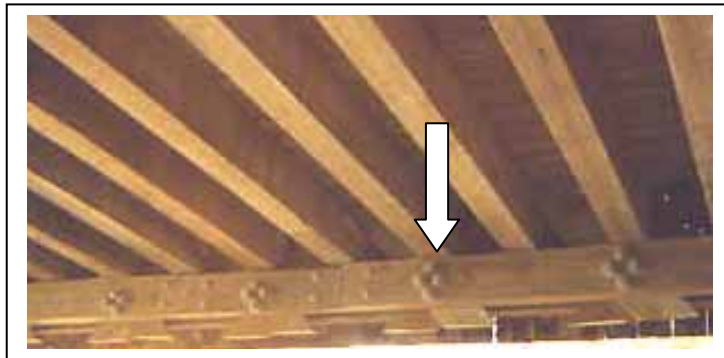

Figure 158. Use of steel bolts in chord replacement—Kingsley Bridge, Shrewsbury, VT.

New Methods of Strengthening Trusses

There are many research, marketing, and trial efforts aimed at using fiber-reinforced polymers (FRP) to reinforce steel and concrete elements. While there is some discussion in research literature concerning their use in timber buildings work, they are not commonly used in covered bridge work. Advances in using these new materials with timber elements may make them important tools for covered bridge work in the future.

FHWA is sponsoring a research program to develop FRP/glulam composites and the related design and material specifications for bridges. Research is also underway to explore strengthening historic covered bridges to carry modern traffic. At the time of this manual's publication, that work was not completed.

Floor System Repair and Strengthening

Floor systems are rarely repaired, because it is usually more economically feasible to replace elements that are deteriorated or damaged. However, in some instances, floor beams with less restricted capacity are strengthened.

Although rare in covered bridges, there are instances of floor beams that have been modified by adding a steel assembly to effectively post-tension the floor beam or convert it to an inverted kingpost truss. Figure 159 shows such an installation. A metal assembly was attached to the underside of a timber floor beam to add capacity. In this example, the beam action of the floor beam has been converted to an inverted queenpost truss.



Figure 159. Installation of metalwork beneath a timber floor beam—Wehr Bridge, Lehigh County, PA.

Another method of strengthening an existing floor system is to replace the decking with glue-laminated panels. Usually, this would also include replacing the existing floor beams with glue-laminated elements. The glue-laminated elements provide higher strength than sawn elements and thereby provide much higher strength with less or no change in the depth of the elements. Figure 160 shows a strengthening of an existing floor system by using glue-laminated deck panels and floor beams. In this instance, the deck panels were fabricated full-length to avoid transverse joints along the floor.



Figure 160. Strengthening by using glue-laminated deck panels and floor beams—Hamden Bridge, Delaware County, NY.

Summary of Recommended Actions

It is very difficult to state with certainty that some actions are acceptable and others are not. The following summarizes how to repair and strengthen historic covered bridges. Many of these “Practices to Follow” and “Practices to Avoid” involve topics other than specific treatment of bridge deficiencies, but are related to successful repair and rehabilitation projects.

Practices to Follow:

- Initiate direct communication with the various entities that will be involved with the project and work together to find a solution to the needs, without assuming that approval will be granted after the fact. Stakeholders include owners, state historic preservation offices, local historic societies, the public at large, and elected officials. These people should be kept informed of the progress of the project, through its various phases, until it is complete.
- Guide selection of design vehicle to the lowest weight possible to minimize the potential need for element replacement.
- Pursue traditional covered bridge practices, including appropriate timber joinery, with appropriate engineering and drawings to guide repair and/or strengthening work.
- Restrict work on historic covered bridges to engineers and contractors with proper credentials and experience on similar timber structures.
- Consider carefully the benefits of design/build projects to allow the engineer and contractor to work as a team for the benefit of the project. Compared with projects for more conventional bridges, the relatively limited number of engineers and contractors experienced with this type of work leads to greater confidence in the outcome of the project if mutual strengths can be joined in a true team spirit.
- Retain the design engineer to observe construction, especially related to superstructure repairs. Some owners rely on the contractor to perform the work with limited or no oversight by the design engineer, or with oversight by persons without experience with timber construction and practices, thereby risking the success of the project.

- Consider how the structure will be supported or moved during the rehabilitation or strengthening to ensure that it is practical, achievable, and safe.

Practices to Avoid:

- Do not attempt to support heavier vehicular loads than necessary for the particular bridge and site.
- Do not close a bridge to vehicular traffic without considering the increased risk of vandalism or arson due to reduced interruption of traffic.
- Do not assume that the original structure is too weak, or unable to be repaired or strengthened for the desired capacity.
- Remember that if the original floor and independent floor support are removed to save the trusses, then continued attention to maintenance and repair of the trusses is mandatory to prevent their unintended demise.
- Be very careful about adding steel components directly adjacent to timber (thereby promoting condensation-caused rot that cannot be observed or inspected).
- Do not add arch elements to a truss without carefully evaluating all forces and stresses created at the connections and arch ends.
- Do not use steel connectors in lieu of timber pegs without carefully considering the consequences of the change in relative stiffness of the connected elements.

Example Projects

Often the best way to depict specifics about covered bridge repair or strengthening is to discuss a particular project. Appendices B, C, and D contain articles that were prepared about recent rehabilitation projects that dealt with three distinct truss types

Chapter 17. Preserving Existing Covered Bridges

The authentic covered bridges that have survived have done so for a combination of reasons. They have not been on heavily traveled roads or in the paths of large floods. They have not been burned or been hit by ice floes. A common factor in their survival, however, has been at least basic, consistent maintenance attention. Most covered bridges that never received attention collapsed long ago or were destroyed when they became unserviceable. Preventive maintenance, if performed regularly, need not be costly, and it provides great short- and long-term benefits.

Establishing a bridge watch practice can help these structures survive. A local person is responsible for ensuring that each covered bridge receives adequate owner maintenance. The program may be organized by a local covered bridge preservation society, by the State Historic Preservation Office, or other agency. Vermont has adopted this practice, and details are presented on the Web site www.vermontbridges.com.

Roofing and Siding

Protecting the main truss members from the elements that cause decay is the most effective way to extend a covered bridge's service life. Properly maintaining the roofing and siding is the most cost-effective component in any covered bridge maintenance program.

When residing the bridge, it is crucial that the details allow good air circulation around the truss members. If there is open space below the eaves and above the siding that enables air to circulate along the length of the bridge, the new siding details should retain that space. If there is no such open space, consider including it with the new siding. Figure 161 provides an example of good siding ventilation details. Note the gap on the far side (more clearly seen than under the eave of the near side) between the top of the siding and underside of the top chord. Also note the use of an inclined top sill board protecting the tops of the vertical siding.



Figure 161. Good siding details—Fitch's Bridge, Delaware County, NY.

Be careful not to nail the siding directly to the truss members. Instead, the siding should be attached to intervening narrow (intermittent) nailers, or wall purlins, to provide good ventilation to both faces of the siding and avoid large areas of direct contact with the main members. These direct contact areas provide an ideal environment for developing and concealing decay. While the siding is light and relatively sacrificial, the truss members are heavy and very difficult and expensive to repair or to replace. Figure 138, presented in chapter 14, depicts a photograph of nailers spaced out from truss elements, consistent with this advice.

Notwithstanding the above advice, it is important to recognize that historical preservationists may often be required by established preservation protocols to insist on repairs consistent with the bridge's original details. The area that is covered by the siding is often of paramount importance to the preservationists. If there was no open zone at the top, they may well disagree with creating one. However, adding a layer of nailers between the truss members and the siding is often an acceptable change, because it improves the service life without markedly altering the look of the bridge. It is vital that those responsible for maintaining the bridges focus on the appearance and durability issues, when educating reviewers about project details.

Windows were often located in covered bridge sidings to both enhance interior illumination and to provide fishing access from within the bridge. The details at the window opening can be critical, in drainage and protection, if they are to avoid premature deterioration in the main truss members near the window opening (see figure 162).



Figure 162. Good siding details around a window—Fitch's Bridge.

Roadway Drainage

A second important regular maintenance activity involves preventing roadway drainage from flowing onto the bridge timbers. An ideal abutment detail situation would incorporate two features: the roadway would ramp up into the bridge, and drainage would be collected at the curbs and piped down the side slopes to avoid eroding the embankment at the abutments. If the approach roadway does not, and cannot, ramp up into the bridge, other measures should be considered to achieve these drainage goals. In some cases, the superstructure can be raised. In other cases, a trench drain can be installed across the roadway to collect runoff and direct it away from the bridge timbers.

The series of photographs presented in figures 163 through 165 depicts issues related to drainage at the entrance of bridges. Figure 163 shows a situation where the roadway slopes directly into the bridge without provision to capture the drainage and channel it away from entering the bridge. Figure 164 presents the long-term consequences of that lack of drainage. When an upgrade ramp into the structure is not possible, good drainage treatment is still possible, by collecting water in a trench drain before it flows into the bridge (see figure 165). This photograph was taken during construction.



Figure 163. Unfortunate approach grading directing drainage into a covered bridge—West Hill Bridge, Montgomery, VT.



Figure 164. Consequences of the poor entrance drainage in figure 163.



Figure 165. A trench drain at a bridge entrance—Fitch's Bridge, Delaware County, NY.

Most covered bridges have no special provisions for removing the water that can be blown or tracked into the bridge. On bridge decks with tight joints, this water seeks another low spot to escape. On decks with loosely spaced planks, water falls down through the floor system. While the structure would be better off without any moisture at all, a certain amount of water is inevitable. In general, intermittent and irregular wetting of an individual element is not harmful, provided that ventilation is sufficient to allow the moisture to thoroughly evaporate without soaking the timber. However, deterioration is common at interfaces of elements subject to periodic wetting, where evaporation will not occur. The top surfaces of floor beams often are significantly rotted beneath the decking.

Foundation Support Details

Covered bridge timbers will deteriorate wherever they come into direct contact with foundation materials. This can be caused by poorly drained rainwater at the abutments, or condensed dew on the masonry. Therefore, the more critical truss members and end floor beams should be supported on sacrificial timber blocking. The blocking should be pressure treated.

The blocking should be solidly supported by concrete or stone foundations and back walls so that critical structural timbers do not directly contact the earth embankment or masonry. Figure 166 depicts good details of sacrificial timber blocking beneath the main truss components.



Figure 166. Sacrificial timbers beneath truss elements.

Timber that is in contact with stone or concrete will eventually rot and decay, even if it is pressure treated. However, because the support blocking can still last 20 to 40 years, its replacement does not represent a major investment over the life of the structure. While replacing these bed timbers usually involves raising the bridge from the foundation, it usually is not a problem for a competent contractor.

This support blocking also allows good air circulation around the main truss members. To be effective, the details should provide an air space at least 50 mm (2 inches) wide between the end of the bridge deck and the back wall, completely across the roadway.

In addition to protection against the rot and decay associated with wood in contact with moist earth, keeping a distinct separation between wood and moist earth will decrease the risk of termite infestation. The section "In Situ Chemical Treatment" below deals with chemical treatments to prevent or control insect infestations in wood. Yet, even if evidence of insect activity in or adjacent to a covered bridge is not apparent, the ground surrounding a covered bridge should be treated regularly by a licensed pest control company. The cost of maintenance is minor compared to the serious damage that can be caused in a relatively short period of time by an insect infestation.

Regular Cleaning

Road traffic tracks a surprising amount of dirt into a bridge. Figure 167 shows common accumulations of roadway debris on top of abutment bearing areas and surrounding truss components. In this case, the ends of the trusses and stringers were also embedded in concrete and asphalt. These accumulations can retain moisture that contributes to timber deterioration. To minimize this deterioration, the superstructure and abutments should be cleaned of such material at least annually. The best debris removal methods involve hand tools and air-blast cleaning. Pressurized water blasting can also be very effective, but introducing any additional water into the structural timbers is not desirable and should be avoided.



Figure 167. Accumulation of debris and asphalt encasing timber elements.

Although the deicing salts that commonly are used on roads in northern environments will be tracked in and will concentrate when the water dries, they do not pose the same inherent serious threat to timber bridges that they do to concrete or metal bridges.

Fire Protection

Arson continues to claim many covered bridges. Fire retarding material was not even an option or consideration when covered bridges were originally constructed. Spray-on fire retardants have been used recently in some repair projects and on some covered bridges. Because the thinner siding and roofing materials are more vulnerable to fire than are the thicker structural truss components, they have occasionally been replaced with products treated with fire retardants. Some covered bridges have even been fitted with sprinkler systems, and others with alarm systems. There is no single, simple, solution to this fire problem. A site-specific evaluation is necessary, and the resulting recommendations should reflect the needs and desires of the bridge's owner and the bridge specifics. "Fire Retardants" in chapter 10 of this manual discusses this fire protection topic in a more indepth manner.

At the time of the publication of this manual, research was underway to identify new generation fire retardant treatments for use on historic covered bridges.

Another practice that may help preserve covered bridges involves educational programs at local schools about the value and unique nature of covered bridges. Educational programs help discourage vandalism, which often results in bridge fires.

In Situ Chemical Treatment

The section "Chemically Treated Wood" in chapter 10 of this manual discusses the evolving topic of chemical treatments that can be applied to bridges to combat infestations of wood-destroying insects, including termites, carpenter ants, and powder post beetles. The treatment regimen will vary according to particular situations, depending on a number of parameters. Chapter 19 of this manual deals with the combined topics of wood preservatives as discussed in this section and of chemical treatment of wood to fight wood-destroying insects.

Painting or Treating Siding

For bridges that have siding that has been treated with a protective finish (either film-forming paint or penetrating stain), regular treatment is necessary, if only to address aesthetic concerns. See “Protective Finish Treatments” in chapter 10 for further discussion of the issues related to this regular maintenance issue.

Retightening Connectors

Changes in moisture content over time can lead to loose connectors. In addition, highly stressed joints may loosen due to repetitive changes in load. The structure should be inspected periodically (every year or so), and all connectors should be checked and tightened as necessary. This is especially true following a bridge rehabilitation, and even more so if green material has been used. Provisions can be added to the rehabilitation contract to require the contractor to return to the structure for that purpose after approximately 6 months.

Chapter 18. Historic Considerations With Existing Structures

A number of agencies are involved with regulating and providing guidance for historic preservation. Proposed work on covered bridges must satisfy each of these entities and conform to several aspects of historic preservation. Further, owners of covered bridges are often especially protective of these treasures, as evidenced by the sign in figure 168.



Figure 168. Bridge at the Green, Arlington, VT.

National Register of Historic Places

One of the most important historic preservation issues for work with covered bridges is the National Register of Historic Places. A good reference for information about this topic is provided on the National Park Service's Web site, <http://www.cr.nps.gov/nr/listing.htm>.

Not all historic covered bridges are listed on the National Register, but most people involved in this aspect of historic preservation believe that most extant covered bridges are eligible to be listed, meaning that they would be listed if the effort were made to follow the application process. Therefore, whether a particular bridge is on the National Register or not does not matter, because most owners and/or funding agencies do not advocate destroying historic covered bridges.

Being listed on the National Register carries with it limitations regarding what actions are possible when considering rehabilitation. There are certain preferred means and methods to rehabilitating historic covered bridges, as described later in this chapter in the section, "Secretary of Interior's Standards for Historic Preservation."

The National Register's listing process is provided on the National Parks Service Web site. There is also a Register of Historic Places in most States, in addition to the National Register. The distinctions between being listed on one or both depends on the State.

Historic American Engineering Record

Established in 1969, in cooperation with ASCE and the Library of Congress, the Historic American Engineering Record (HAER) is a National Park Service program responsible for compiling a national archive of America's engineering, industrial, and technological achievements of historic interest. The collection contains nearly 3,500 sheets of measured and interpretive drawings, 72,000 large-format photographs, 61,000 data pages, and 1,000 color transparencies on more than 7,000 sites, structures, and objects. The collection is curated and made available to the public by the U.S. Library of Congress; it is also one of the first available online as part of the National Digital Library (www.memory.loc.gov/ammem/hhhtml/hhhome.html). The collection includes documentation on more than 100 covered bridges.

HAER, in cooperation with FHWA, is conducting a 3-year project to complete documentation on a selection of America's outstanding covered bridges. In addition to HAER documentation, it is proposed that a selection of bridges will be nominated as National Historic Landmarks, a traveling exhibit is planned, a best practices workshop was held at the University of Vermont, June 5-7, 2003, and a Web page for covered bridges is planned.

State Historic Preservation Offices

In practice, there are varying degrees of interest, knowledge, and interpretation of National Register issues in the various State Historic Preservation Offices. For example, some may believe that it is acceptable to allow floor systems to be removed from extant bridges and replaced by an independent floor system, while others would not tolerate such an act. Therefore, it is important to coordinate with the State office for the project under consideration. Further, it is particularly important to initiate contact with that office early in the project to identify special interests or concerns.

Some projects include unusual features deserving special consideration by the State office, like these ornate timber gates used to restrict this bridge to pedestrians and bicycles (see figure 169).



Figure 169. Comstock Bridge, East Hampton, CT

The Advisory Council on Historic Preservation

The Advisory Council on Historic Preservation is an independent Federal agency that provides a forum for influencing Federal activities, programs, and policies as they affect historic resources. The goal of the

National Historic Preservation Act (NHPA), which established the Council in 1966, is for Federal agencies to be responsible stewards of our Nation's resources when actions affect historic properties. The Council is the only entity with the legal responsibility to balance historic preservation concerns with Federal project requirements.

As directed by NHPA, the Council:

- Advocates full consideration of historic values in Federal decisionmaking.
- Reviews Federal programs and policies to promote effectiveness, coordination, and consistency with national preservation policies.
- Recommends administrative and legislative improvements for protecting our Nation's heritage with due recognition of other national needs and priorities.

The Advisory Council normally is not involved directly in establishing the goals of a particular covered bridge preservation project. Instead, the State Historic Preservation Office coordinates with the Council as necessary.

Some historic structures have been converted for unusual use, leading to interesting evaluations of proposed projects. Figure 170 depicts an example of what some historic covered bridges are used for after serving their useful life for vehicular traffic. This is the museum inside the Shushan Bridge in Washington County, NY.



Figure 170. Museum at Shushan Bridge—Washington County, NY.

U.S. Secretary of Interior's Standards for Historic Preservation

The U.S. Secretary of the Interior developed "Standards and Guidelines for Archeology and Historic Preservation" under the authority of Sections 101(f), (g), and (h), and Section 110 of the National Historic Preservation Act of 1966 (http://www.cr.nps.gov/local-law/arch_stnds_0.htm). These standards and guidelines are not regulatory and do not set or interpret Agency policy. They are intended to provide technical advice about archeological and historic preservation activities and methods.

A good reference for these standards is summarized on an Internet site hosted by the Advisory Council on Historic Preservation at: <http://www.achp.gov/secstnd.html>. An important distinction is made among various types of anticipated preservation work—rehabilitation, reconstruction, and restoration.

As taken directly from that site:

Rehabilitation (treatment)—the act or process of returning a property to a state of utility through repair or alteration which makes possible an efficient contemporary use while preserving those portions or features of the property which are significant to its historical, architectural, and cultural values.

Reconstruction (treatment)—the act or process of reproducing by new construction the exact form and detail of a vanished building, structure, or object, or any part thereof, as it appeared at a specific period of time.

Restoration—the act or process of accurately recovering the form and details of a property and its setting as it appeared at a particular period of time by means of the removal of later work or by the replacement of missing earlier work.

In brief, restoration and reconstruction are preservation actions that focus on the preservation with less consideration of the structural needs of the work. Rehabilitation allows less intensive preservation and more consideration of structural needs.

For covered bridges that vehicles continue to use, the structural demands often require strengthening that alters the original construction. That type of work usually involves rehabilitation rather than restoration. Consequently, rehabilitation may result in retaining less original fabric.

There is controversy as to what makes a covered bridge historic. Some believe a bridge is important because it is a physical relic and the material is historic. Some believe that a covered bridge is historic because it embodies a special idea or concept. As noted elsewhere in this manual, various components of an historic covered bridge have probably been replaced at least once during its life (e.g., roofing, siding, flooring); hence, some believe that replacing those items in subsequent repair projects is acceptable. Others place more emphasis on replacement in-kind and only when necessary.

The decision regarding the type of preservation treatment for a given bridge is, therefore, complex and should be made in consultation with the various stakeholders involved—owners, engineers, and State Historic Preservation Officers (or designated representatives), at a minimum.

The engineer's input is vital to establish what work may be necessary for a given desired end. Including one or more local contractors who are experienced with authentic covered bridge work is critical in the early planning process to ensure the project's success. Contractors interested in the work on the particular project may not want to jeopardize their potential award of the work due to a perceived conflict of interest.

The National Park Service also sponsors the Historic Preservation Training Center (HPTC) in Frederick, MD. The HPTC is devoted to preserving and maintaining historic structures. The center is working to produce best practices guidelines for covered bridges based on the U.S. Secretary of the Interior's Standards.

Chapter 19. Initial Preservative Treatment of Wood in Covered Bridges

Introduction

The chapter provides information on treatment chemicals, pretreatment specifications, and pertinent standards that help specify wood for covered bridges that will resist biodeterioration. Wherever possible, consult the original standards to confirm that the chemicals suggested are suitable for a particular application.

Historic covered bridges were masterpieces of design that allowed untreated wood to survive for many decades. However, in most covered bridges, some members eventually succumb to decay or insect attack. This chapter discusses options for preservative treatment of the replacement members, while considering factors such as appearance, odor, durability, availability, and environmental concerns.

The basic design premise employed in covered bridges is to limit exposure to water, which is one of the essential elements for biodeterioration. All organisms capable of substantial biodegradation have four basic needs: adequate temperature, oxygen, water, and a food source. The temperature ranges for most decay organisms are broad. They survive temperatures well below freezing and above 40°C (104°F) and do best between 16 and 32°C (64.4 and 89.6°F), depending on the organism. Most wood-degrading organisms are aerobic and require oxygen, but many organisms are adapted for low-oxygen environments. As a result, few strategies for preventing decay limit oxygen or temperature.

Water is essential for nearly all fungal action. It swells wood, and at higher levels, it serves as a diffusion medium for fungal enzymes and the breakdown products they produce, and is a reactant in the processes whereby the carbohydrate components of the wood are broken into smaller fragments.

Most wood-degrading agents require that free or liquid water be present in the wood before substantial attack can occur. The point where liquid water is present is called the fiber saturation point, and, for most wood species, falls between 24 and 32 percent (water-to-wood weight ratio). Covered bridges were constructed to limit the potential for the bridge deck and superstructure to become wet enough to allow fungal attack.

Wood is usually the food source for decay (although some agents, notably carpenter ants, do not consume wood as a food source). Bridge designers have poisoned this food source, depending on naturally toxic compounds present in the heartwood of those species, or, when these chemicals are absent, adding supplemental chemicals to preserve the wood.

Decay is therefore most likely to occur on decay-susceptible wood species that are exposed where they are likely to become wet above the fiber saturation point under temperature regimes favorable for growth. One can predict the rate of decay out of direct soil contact by evaluating the number of days per month with measurable rainfall and the average monthly temperature. These data are used to construct a climate index. The Scheffer Climate Index is one example of this approach and produces values from 0 to 400 for low to extremely high decay hazards, respectively. Thus, a bridge in southern Mississippi is at much greater risk for decay than a similar structure in northern Maine. These indices are reasonably predictive for above ground exposures, but are poor predictors of wood performance in direct soil contact.

Evaluating the Need for Preservative Treatment

Preservative treatment of replacement members in covered bridges may not be necessary in bridges where the wood will not become wet or where there is no risk of insect attack, but the wood in most bridge components will last longer if it receives some type of supplemental treatment. In most environments, wood must be exposed to liquid water to accumulate enough moisture to cause decay. Even in humid climates, the moisture content of wood protected from precipitation is typically below 25 percent. Covered bridge designers were aware of this moisture content relationship and effectively used it to protect the

bridge components. However, even in a covered bridge, it is difficult to protect wood from liquid water continuously, and several areas of the structure are particularly susceptible to wetting. Perhaps the most important of these are supports such as sole plates members that directly contact the ground, stone, or masonry. Other areas of exposure are the weatherboarding and members near the ends of the bridges where wind-driven precipitation can reach the interior of the structure. The risk of deterioration in a covered bridge depends upon the wood species, amount of rainfall, local temperature, and ability of various design elements to shed or exclude moisture. Thus, the risk of fungal attack on interior members not exposed to wetting will be low, while large timbers exposed to wetting can experience considerable degradation.

Decay risk also can be affected by the presence of water-trapping joints between members, bolts, or connectors that channel water into the interior, and other features that encourage water ingress. While covering a bridge deck reduces the risk of biodeterioration, it cannot completely eliminate that risk.

Perhaps the most reliable indicator of whether a replacement member should be treated with preservatives is the condition of the member being replaced. If the member being replaced had suffered biological attack, and no significant changes were made in the structure to remedy the sources of moisture for that member, then preservative treatment should be strongly considered.

Types of Deterioration

Covered bridges are primarily susceptible to attack by fungi and insects, although birds such as woodpeckers and some mammals (such as voles or porcupines) can physically damage the wood as they seek food, shelter, or nesting sites.

The fungi that attack wood are divided into five broad groups, based on the type of damage they cause. All of these fungi have life cycles that begin with simple spores that land on the wood and germinate to produce hyphae that grow into the wood, where their enzymes degrade specific components of the wood. After it obtains enough energy, the fungus produces more spores, and the cycle is repeated. Fungal spores are almost always present in the air. For example, a single fungus-fruiting structure can produce nearly one billion spores in a single day. As a result, favorable conditions for fungal attack will inevitably lead to decay.

Molds and Stains

These fungi generally grow through the ray cells, which store starches and other compounds in living trees. Stain and mold generally do not attack the structural components of the wood, and their damage is primarily cosmetic. Mold fungi produce prodigious amounts of pigmented spores on the wood surface; these can be removed by brushing. Stain fungi discolor the wood green, blue, or black with brownish pigments produced in the hyphae growing within the wood. This damage penetrates deep into the sapwood and cannot be removed by brushing.

Decay Fungi

Decay fungi all affect cellulose, hemicellulose, or lignin in the wood cell and can cause substantial reductions in material properties. The three types of attack can be distinguished based on the appearance of the decayed wood.

Soft rot fungi cause a gradual degradation from the surface inward and primarily attack cellulose and hemicellulose. These fungi are more prevalent in very wet environments, in agricultural soils, or on certain preservative treatments. In covered bridges, this damage is most likely to occur wherever bridge timbers abut locations where water can collect. Soft rot attack gradually softens the outer surface of both hardwoods and softwoods. Because the attack occurs on the surface, soft rot damage can be particularly important where members are used in bending. Because of the high moisture content, the wood may

appear mushy. In general, however, soft rot damage is likely to be less common than other types of damage.

Brown rot fungi also attack both cellulose and hemicellulose, but their damage is primarily internal. These fungi are a serious concern, because they tend to rapidly break down cellulose at considerable distances from where the fungus is growing. As a result, these fungi cause substantial strength losses at very early stages of attack. Brown rot fungi tend to be more prevalent on coniferous wood species. In the early stages of decay, the wood surface lacks luster and appears dull or dead, and as the decay progresses, the wood develops a brown discoloration, with cross grain checking, collapse, or crumbling, and abnormal shrinkage. The appearance is similar to wood that has been charred. Wood that has been brown rotted and subsequently dried is sometimes mistakenly referred to as dry rotted wood. If the decay has developed within a member, it may not be readily visible, but symptoms such as crushing of the wood or excessive shrinking may be apparent.

White rot fungi use all three of the structural polymers that make up wood and, at their extreme, can cause up to 97 percent weight loss. White rot attack tends to become visible as strength effects become apparent. White rot fungi are most common on hardwoods. In the early stages of decay, the wood may have a bleached appearance, and black zone lines may appear in these lighter areas. Hardwoods suffering from white rot attack do not crack across the grain or shrink excessively like brown rotted wood, unless they are severely degraded.

In general, symptoms of fungal decay include the presence of fruiting bodies (mushroom-type growths), sunken faces or localized depressions, staining or discolorations that indicate wetting, or the presence of soil, plant growth, or moss growth.

Wood Boring Insects

While a variety of insects can attack wood, three groups are responsible for most of the damage: powder post beetles, termites, and carpenter ants.

Powder post beetles are capable of attacking wood that is below the fiber saturation point, allowing them to attack timbers in the bridge superstructure that are protected from direct wetting.

Powder post beetles lay their eggs on the surface of untreated, noncoated sapwood of the desired species. The eggs hatch into larvae that tunnel into the wood, leaving little evidence of their presence inside the wood. The larvae tunnel extensively through the wood over periods extending for 1 to 7 or more years. After the larvae have obtained a sufficient amount of energy, they pupate to become adults. These adults then exit the wood, leaving round exit holes on the wood surface. This is often the first visible sign of an infestation. The inside of powder post-damaged wood tends to be crumbly and powdery. Prevention is easiest by applying paint or other sealing finishes to the wood.

Termites are social insects that live in large colonies organized in a caste system containing workers, soldiers, and reproductives. Three types of termites attack wood products. Dampwood termites are confined to the Pacific Northwest, where they attack very wet wood in a variety of environments. Damage from these termites is most easily controlled by eliminating the source of moisture, although preservative treatments are also effective. Where it is not possible to eliminate the source of moisture, preservative treatment remains the only option.

Subterranean termites are found in most regions of the United States below 50°N latitude and are distinguished by nests in soil contact. Native subterranean termites live in colonies up to one million workers. Although they require moisture for attack to occur, these termites can produce mud tunnels from the soil over nonwood obstacles and into wood that is not in direct soil contact. Workers then carry wet soil up the tubes, providing moisture that allows them to attack the otherwise dry wood. Subterranean termites cause an estimated \$1 billion in damage per year, but their importance in some regions is likely to be overshadowed by an imported termite species, the Formosan termite (*Coptotermis formosanus*). Although the range of this species is largely confined to major ports along the Gulf Coast as well as most

of the Hawaiian islands, the voracious nature of this insect has raised concerns among many wood users. Formosan termites nest in colonies as large as five million workers. These termites attack virtually all wood species and have even been known to penetrate wood with low preservative levels. The best method for preventing termite attack in covered bridges is to use wood that has been pressure treated with preservatives.

Dry wood termites, unlike other termites, can attack very dry wood above the ground. Found primarily in the desert Southwest, these insects leave little sign of their attack and are difficult to control. Fortunately, drywood termites are not often found where covered bridges are used extensively.

Carpenter ants are also social insects with castes of workers, soldiers, and reproductives, but differ in a number of important characteristics from termites. While termites are rarely seen outside the nest, carpenter ants must forage outside the nest for food. Carpenter ant workers are typically dark-colored and have constrictions between the body segments, while termites are cream-colored and lack constrictions on the body. Most importantly, termites use wood as a food source, while carpenter ants do not; they mine the wood to create galleries to rear their young. This sometimes makes it difficult to control carpenter ant attacks. Carpenter ants attack wood in a variety of environments, including pressure-treated wood.

Preventing Fungal and Insect Attack

Although a variety of organisms have evolved to utilize wood for food or habitat, there are numerous strategies for preventing this damage.

Ideally, wood kept below the fiber saturation point should be free of fungal attack, but can be susceptible to powder post beetles, carpenter ants, or termites. The two approaches to limiting deterioration are to use natural durable heartwood or nondurable woods that have been supplementally protected with chemicals.

The heartwood of some native species, such as redwood, western red cedar, eastern white cedar, white oak, osage orange, and black walnut has natural durability that may be sufficient to prevent decay in moderate exposures. As the sapwood of these species dies inside a living tree, it undergoes reactions that produce a series of toxic chemicals. One must stress that it is typically only the heartwood that has enhanced durability, and that the proportion of heartwood that it is practical to achieve in a member must be a consideration. For example, although heartwood of Southern Pine species may be similar in durability to that of Douglas Fir, it is very difficult to obtain large Southern Pine timbers with a high proportion of heartwood. Conversely, larger members cut from Douglas Fir trees typically contain a high proportion of heartwood. While naturally durable heartwoods resist insect and fungal attack, the degree of resistance can vary widely from tree to tree and even within the same tree. As a result, structures of naturally durable woods can exhibit variable performance, particularly in direct soil contact. In general, naturally durable woods perform best when used above ground as decking or sheathing.

While naturally durable heartwoods remain an attractive option for some applications, many of the naturally durable species have lower structural properties that limit their usefulness in highway structures and are more costly than other species. As an alternative, the use of nondurable species supplementally protected with synthetic preservatives typically is recommended.

Methods of Preservative Treatment

Attempts to protect nondurable woods from deterioration date back thousands of years, but effective wood preservation dates to the 1830s, when John Bethell patented creosote as a preservative and the Bethell, or full cell process, for delivering it into the wood. These two patents form the foundation of the current preservation industry.

Preservation seeks to render wood either toxic to the deteriorating organisms or unrecognizable as a substrate. In either case, the goal is to deliver a specific amount of chemical (retention) to a specified

depth. The depth to which the treatment penetrates depends on the wood species and its intended use. For example, penetration requirements are greater in thick sapwood species such as Southern Pine than in thin sapwood species like Douglas Fir or White Oak. These differing requirements reflect the difficulty of moving liquids through heartwood as well as the knowledge that sapwood has little decay resistance. As a result, the goal of most treatments is to protect the shell of sapwood surrounding the untreated heartwood core.

There are a variety of methods for delivering chemicals into wood. Brushing is, by far, the simplest method for providing supplemental protection, but it also produces the shallowest depth of treatment. Brush treatments typically are used to provide supplemental protection when treated wood must be cut after treatment, although there is some evidence that it also improves the performance of naturally durable woods.

Dipping in preservative is used for some wood products, including windows, door frames, and pallets. In the former two instances, the shallow protection is adequate because the wood is usually coated and protected from the weather. Pallets are relatively low-value commodities that have limited service lives, making more elaborate treatments uneconomical. Dipping is also used to treat framing lumber with borates in New Zealand. Wood is dipped in a concentrated boron solution, and then stored for 30 to 45 days to allow diffusion. This process is not widely used in North America.

In general, brushing and dipping do not adequately penetrate preservative, and they are largely relegated to supplemental protection of either naturally durable or preservative-treated woods.

The most effective methods for supplemental wood protection involve using combinations of vacuum and pressure to force chemicals into the wood. The two basic approaches to pressure impregnation are the full and empty cell processes. Both are performed in pressure vessels. The goal of these treatments is to deliver a specific weight of chemical per unit area of wood (expressed on a pounds per chemical/cubic foot of wood or kg/m^3 basis) to a specific depth.

The full cell process begins with a vacuum to remove as much air as possible from the wood, then adds solution under vacuum and raises pressure. As the vacuum is released, preservative is drawn into the wood. Increasing pressure then forces more chemical into the wood. Pressure is held until the desired solution is injected. The pressure is then released, and vacuum and heating periods recover excess solution and clean the wood surface. Full cell cycles produce maximum solution uptake in the treated zone. They are typically used to treat wood with creosote to marine retentions (very high loadings) or for water-based systems where water is a cheap solvent and treatment chemical concentrations can be adjusted to produce the desired retention.

The empty cell processes eliminate the initial vacuum and were designed to reduce the amount of treatment solution deposited in the wood (i.e., retention). When pressure is introduced, it traps and compresses a pocket of air. At the end of the process, the compressed air pocket expands, carrying excess preservative from the wood. This reduces the overall chemical loading in comparison with the full cell process. There are a number of variations on the empty cell process, but all are designed to reduce retention. Empty cell processes are widely used for treating wood in timber bridges.

Environmental Considerations for Treatment

For decades, wood users believed that more chemicals were better and that surface appearance was of little concern. Changing societal values and increasing environmental awareness have altered these concepts. It is now recognized that poor treatment practices can lead to surface bleeding of preservative, excessive leaching, and a far greater potential for environmental impact.

It is important to specify standards that allow the treater to produce an environmentally friendly product. The American Wood Preserver Association (AWPA) preservative retention standards (Use Category Standards (UC) 4 and 5) are sufficient for a long-lasting, durable product.^[22] Asking the treater to increase the retention beyond these guidelines increases the amount of leachable chemicals in the wood without a noticeable service gain. Similarly, retreating wood that has failed to meet AWPA standards for

initial retention increases the leachable material present. Selecting material free of surface residues is another way to assist in minimizing environmental risk. Allowing time for the use of proper treatment practices is also important. A common complaint of treaters is that customers demand the treated product on very short notice. This can cause the treater to rush or delete processing steps that improve the final product. This problem is especially relevant to post-treatment conditioning of water-based preservatives.

Post-treatment conditioning, or fixation, is necessary to reduce leaching from water-type preservatives. The active ingredients of various water-based wood preservatives (copper, chromium, arsenic, and zinc) are initially water soluble in the treating solution, but become resistant to leaching when placed into the wood. This leach resistance is a result of the chemical fixation reactions that render the toxic ingredients insoluble in water. The mechanism and requirements for these fixation reactions differ depending on the type of wood preservative. Some reactions occur very rapidly during pressure treatment, while others may take days or even weeks to reach completion, depending on post-treatment storage and processing conditions. If the treated wood is placed in service before these reactions are completed, the initial release of preservative into the environment may be many times greater than for wood that has been adequately conditioned. The AWPA has recently formed several task forces to consider the development of fixation, or leaching minimization, standards for CCA-C and other wood preservatives; however, there are currently no nationally recognized standards for fixation of waterborne preservatives in the United States.

Oil-type preservatives offer a unique difficulty, in that such preservatives sometimes bleed to the surface of the wood. This problem may be apparent immediately after treatment, but in some cases the problem does not become obvious until after the product is placed in service in a location where it is exposed to direct sunlight. The volume of preservative that bleeds out of the wood and may drip into the environment is typically quite small, but it may appear much larger if it spreads on the surface of standing water. It should be made clear that pieces with oily surfaces (or bleeders) will not be accepted when specifying wood treated with oil-type preservatives. However, bleeding is not always apparent initially, and may occur later when the wood is placed in service. This problem is best addressed by controlling treatment processes. The processes that reduce bleeding vary somewhat, depending on the type of preservative. The treaters also typically use a combination of these processes to obtain a clean surface. Some of the key steps include maintaining clean facilities and working solutions, avoiding over-treatment, and using post-treatment conditioning techniques such as final vacuum, steaming, and expansion baths.

Construction practices can also make a difference in preservative released into the environment. Treated material shipped to the job site should always be stored free from standing water and wet soil, and protected from precipitation. Field fabrication of treated wood that cannot be handled before applying treatment should be done carefully. Construction debris like sawdust has a disproportionately high surface-area-to-volume ratio, leaching more chemicals into water. Taking practical steps to collect such debris can minimize the threat.

In some regions of the country, the industry has responded to environmental concerns by developing a series of best management practices (BMPs) designed to fix or immobilize preservative, produce retentions that are reasonably close to the target, and reduce the risk of bleeding from the finished product. While BMPs are not mandatory, their use is highly recommended for any treated wood used over or in water. Where applicable, descriptions of appropriate BMPs are included for the preservatives discussed in this chapter.

Treatment Specifications

The primary standards for pressure treatment of wood in the United States are promulgated by AWPA, which are widely referenced in the AASHTO standards. Founded in 1904, the AWPA is a consensus standards-writing body consisting of wood treaters, chemical suppliers, and general interest members. The primary objective of the AWPA standards is to protect the consumer or user of treated wood products.

The AWPA standards specify treatments according to the risk of decay and the commodity. Thus, for the same decay hazard, specifications will be far more rigorous for a bridge timber than for a fence post. In

addition, the standards recognize regional differences in wood species employed. Covered bridge designers have always experienced difficulties in using the AWPA standards because of requirements to incise some difficult-to-treat species and the lack of nonpigmented preservatives for many applications.

While it may occasionally be necessary to refer beyond the AWPA standards, the goal of these standards is to assist designers in specifying properly protected wood without compromising the aesthetics of the finished product.

AWPA standards are considered to be minimums for chemical loading and penetration. Specifications may be made more rigorous; however, it should be clear that the intended change and the associated costs truly improve reliability. In addition, the AWPA standards are results-oriented; within specific process limitations, the method for achieving the desired retention and penetration is largely left to the treater.

Methods for Improving Performance of Treated Wood

The performance of treated wood is largely a function of the initial treatment quality. The primary goal of treatment is to produce an envelope of protection around the untreated core. Any damage to this treated shell opens the interior to possible fungal or insect attack. These openings can be created naturally through the development of seasoning checks that extend beyond the original depth of treatment, or they can originate from damage due to cutting, notching, or drilling a member after treatment.

To limit the risk of these problems, the wood should be seasoned before treatment. This helps ensure that checks have already formed and creates a better treatment envelope. However, seasoning to in-service conditions is generally not practical. Most large timbers are treated while their core moisture contents are above 30 percent, a practice that guarantees the development of some post-treatment checking. Wherever possible, simple practices such as placing the member so that the largest check faces down in a structure can reduce the risk of wetting through checks.

It is nearly impossible to completely eliminate the need for onsite fabrication; however, a majority of cutting and drilling can be done before treatment. In cases where holes must be redrilled because of twisting or slight misalignments, application of preservative to the freshly exposed wood is recommended.

In addition to drying and precutting/boring, preservative penetration can be improved in many species by incising, a process that drives metal teeth 15.2 to 19 mm (0.6 to 0.75 inches) into the wood. Incising opens the wood to flow and improves treatment to the depth of the incisions. Incising is required to effectively treat many thin sapwood conifers as well as many hardwoods. While it reduces strength (up to 15-20 percent on 2 by 4s), the effect is reduced as timber size increases, and any losses are more than offset by the improved performance of the treated wood.

In some instances, even for historic structures, it may be more advantageous to substitute engineered wood products or smaller sizes of timber that are either less likely to check or be treated evenly. A large timber is aesthetically pleasing, but it is far more prone to checking and has a proportionally smaller treated area than several smaller timbers bolted together. The smaller timbers will be better treated and are less likely to develop deep checks. Similarly, substituting glue-laminated beams or laminated veneer lumber can produce products that are less likely to check in-service because they are thoroughly dried before treatment. Clearly, these products must be used carefully to retain the historic character of the bridge, but they offer considerable advantages with regard to treatment characteristics.

Preservative Chemicals

Wood preservatives are generally classified or grouped by the type of application or exposure environment in which they are expected to provide long-term protection. Some preservatives have sufficient leach resistance and broad spectrum efficacy to protect wood that is exposed directly to soil and water. These preservatives also will protect wood exposed above ground, and may be used in those applications at lower retentions (concentrations in the wood). Other preservatives have intermediate

toxicity or leach resistance that allows them to protect wood fully exposed to the weather, but not in contact with the ground. Still other preservatives lack the permanence or toxicity to withstand continued exposure to precipitation, but may be effective with occasional wetting. Finally, there are formulations that are readily leachable to the extent that they can only withstand very occasional, superficial wetting. It is not possible to evaluate a preservative's long-term efficacy in all types of exposure environments, and there is no set formula for predicting exactly how long a wood preservative will perform in a specific application. This is especially true for above-ground applications, because preservatives are tested most extensively in ground contact. To compensate for this uncertainty, the tendency is to be conservative in selecting a preservative for a particular application.

Preservatives are also classified by their solubility in either water- or oil-type solvents. This classification is not always absolute, because some preservatives can be formulated to be used with either type of solvent. Water-based preservatives often include some type of cosolvent, such as amine or ammonia, to keep one or more of the active ingredients in solution. Each solvent has advantages and disadvantages depending on the application.

Oil-type systems are among our oldest and most effective preservatives. These systems are usually used in medium to heavy oils that leave the wood surface a dark brown color, although some lighter solvents can minimize color changes. Oil-based systems are widely believed to experience reduced checking and splitting, although this is often difficult to document. Oil-based systems have provided excellent protection in a number of highway applications and are compatible with most wood species. These systems can be very difficult to paint or stain because the initial oil preservative can migrate through or discolor the coating. The use of more volatile solvents can reduce this problem.

Water-based preservatives are often used when cleanliness and paintability of the treated wood are required. Wood treated with water-based preservatives also typically has less odor than wood treated with some types of oil-based preservatives. However, unless supplemented with a water repellent, the water-based systems do not confer dimensional stability to the treated wood. In addition, water-based preservatives that use copper as a fungicide may not adequately protect hardwood species under conditions that favor soft rot attack. (As mentioned above, the high moisture levels needed to promote soft rot attack are unlikely to occur in covered bridge components.) Some water-based preservatives may increase the rate of corrosion of mild steel fasteners. The most widely used waterborne treatment is a mixture of chromic acid, cupric oxide, and arsenic pentoxide, called chromated copper arsenate (CCA). Developed in India in the 1930s, CCA is used to impregnate 60 percent of the wood treated in the United States. CCA is strongly fixed to the wood and has provided excellent protection in a variety of environments. The primary drawbacks to CCA are those associated with any heavy metal preservatives. While CCA is fixed, small amounts of copper and arsenic are continually solubilized, and those losses have raised environmental concerns. Over the past 10 years, a variety of alternative chromium and/or arsenic-free systems have been developed, but none has had the cost and performance advantages of CCA. As a result, alternatives such as ammoniacal copper quat, ammoniacal copper zinc arsenate, and copper azole have relatively small U.S. markets. It is also notable that all of the recently standardized CCA alternatives contain, and appear to leach, much higher levels of copper than does CCA. Thus, it is probably advisable to use available aquatic models to assess the risk of copper leaching where invertebrate fish may be sensitive to copper concentrations in water and sediment. However, these alternative treatments are available commercially and may be appropriate where CCA is not considered to be suitable.

Each preservative also has many unique characteristics that might affect its suitability for a particular application. These include factors such as appearance, odor, toxicity, wood species compatibility, and availability. All of the preservatives mentioned in the sections below are registered with the U.S. Environmental Protection Agency (EPA) for use as wood preservatives.

In some instances, the preservative may be classified as a restricted-use pesticide, meaning that the applicator must be licensed by the appropriate State agency to apply chemicals. The use of preservative treated wood, however, does not require a license, even if the treatment chemical is classified as a restricted-use pesticide.

Preservatives That Are Effective in High-Decay Hazard Applications

These preservatives exhibit sufficient toxicity and leach resistance to protect wood in contact with the ground or in other high-moisture, high-deterioration hazard applications. In bridges, these types of applications may include sole plates resting on piers or wooden members that directly contact footings in abutments or approaches. Preservatives listed in this section are also effective in preventing decay in other, less severe exposures.

Water-Based Preservatives

Acid Copper Chromate (ACC)—Acid copper chromate (ACC) has been used as a wood preservative in Europe and the United States since the 1920s. ACC contains 31.8 percent copper oxide and 68.2 percent chromium trioxide. The treated wood has a light greenish-brown color, and little noticeable odor. Tests on stakes and posts exposed to decay and termite attack indicate that wood impregnated with ACC gives acceptable service, although it may be susceptible to attack by some species of copper tolerant fungi. It is listed in AWPAs standards for a wide range of softwood and hardwood species, with a minimum retention of 4.0 or 8.0 kg/m³ (0.25 lbs/ft³ or 0.5 lbs/ft³) for wood used above ground or in ground contact, respectively. However, in critical structural applications such as highway construction, its AWPAs listings are limited to sign posts, handrails, guardrails, and glulam beams used above ground. It may be difficult to obtain adequate penetration of ACC in some of the more refractory wood species such as White Oak or Douglas Fir. This is because ACC must be used at relatively low treating temperatures (38°C to 66°C (100°F to 150°F)), and because rapid reactions of chromium in the wood can hinder further penetration during longer pressure periods. The high chromium content of ACC, however, has the benefit of preventing much of the corrosion that might otherwise occur with an acidic copper preservative. Only a limited number of treatment facilities use ACC, primarily for treating wood used in cooling towers.

ACC does not contain arsenic and thus may offer environmental and handling advantages in some applications. The treatment solution does utilize hexavalent chromium, but the chromium is converted to the more benign trivalent state during treatment and subsequent storage of the wood. This process of chromium reduction is the basis for fixation in ACC, and is dependent on time, temperature, and moisture. Fixation standards or BMPs have not yet been developed for ACC, because of its relatively low usage. As a general guide, the fixation considerations discussed for CCA (see below) can be applied to ACC.

Ammoniacal Copper Citrate (CC)—Ammoniacal copper citrate (CC) is a wood preservative that uses copper oxide (62 percent) as the fungicide and insecticide, and citric acid (38 percent) to help distribute copper within the wood structure. The color of the treated wood varies from light green to dark brown. The wood may have a slight ammonia odor until it is thoroughly dried after treatment. Exposure tests with stakes and posts placed in ground contact indicate that the treated wood resists attack by both fungi and insects. However, it is possible that the lack of a cobioicide may render the wood vulnerable to attack by certain species of copper-tolerant fungi. CC is listed in AWPAs standards for treating a range of softwood species and wood products. The minimum CC retention is 4.0 and 8.0 kg/m³ (0.25 and 0.4 lb/ft³) for wood used above ground or in ground contact, respectively. CC is not listed in AWPAs standards for use in highway construction or other structurally critical applications (the AWPAs standards typically employ higher preservative loadings for highway construction in consideration of the need for a higher level of reliability than might be required for fence). As with other preservatives containing ammonia, CC has an increased ability to penetrate into difficult-to-treat wood species such as Douglas Fir. The CC treatment can accelerate corrosion in comparison to untreated wood, necessitating the use of hot-dipped galvanized or stainless steel fasteners. Few treating plants currently use CC, and wood treated with this product may not be readily available in most areas.

CC does not contain arsenic or chromium, and thus may offer environmental or safety advantages in some situations. The copper is solubilized by the ammonia in the treating solution, and becomes insoluble (fixed) as the ammonia volatilizes from the wood. Wood treated with CC should not be exposed to precipitation or other sources of environmental moisture until this fixation process is complete. This time period varies with temperature. If the wood arrives at the job site appearing heavy, wet, and with a

strong ammonia odor, it may not be thoroughly fixed. Fixation can be ensured by placing sticks between courses of the wood (stickering) and placing it in an area with good air flow to facilitate drying. Although the wood should be covered to protect it from precipitation, it should not be covered in a way that impedes air circulation until after it has dried and the ammonia odor has dissipated. There currently are no fixation standards or BMPs to ensure fixation in CC-treated wood. However, the BMPs developed by the Western Wood Preservers Institute (WWPI) for ammoniacal copper zinc arsenate (ACZA)-treated wood are applicable (see below).^[25]

Alkaline Copper Quat (ACQ)—Alkaline copper quat (ACQ) is one of several wood preservatives that has been developed in recent years because of environmental or safety concerns with CCA. The fungicides and insecticides in ACQ are copper oxide (67 percent) and a quaternary ammonium compound (quat). Multiple variations of ACQ have been standardized or are in the process of standardization. ACQ type B (ACQ-B) is an ammoniacal copper formulation, ACQ type D (ACQ-D) is an amine copper formulation, and ACQ type C (ACQ-C) is a combined ammoniacal-amine formulation with a slightly different quat compound. ACQ-B-treated wood has a dark greenish-brown color that fades to a lighter brown, and may have a slight ammonia odor until the wood dries. Wood treated with ACQ-D has a light brown color and little noticeable odor, while wood treated with ACQ-C varies in appearance between that of ACQ-B and ACQ-D, depending on the formulation. Stakes treated with these three formulations have demonstrated efficacy against decay fungi and insects when exposed in ground contact. The ACQ formulations are listed in AWWPA standards for a range of applications and many softwood species, although the ACQ-C listings are limited because it is the most recently standardized. Minimum retentions of 4.0, 6.4, or 9.6 kg/m³ (0.25, 0.4 or 0.6 lbs/ft³) are specified for wood used above ground, in ground contact, or for highway construction, respectively. The multiple formulations of ACQ allow some flexibility in achieving compatibility with a specific wood species and application. When ammonia is used as the carrier, ACQ has improved ability to penetrate into difficult-to-treat wood species. However, if the wood species is readily treated, such as Southern Pine, an amine carrier can be used to provide a more uniform surface appearance. All of the ACQ treatments accelerate corrosion of metal fasteners relative to untreated wood, and hot-dipped galvanized or stainless steel fasteners are a necessity. The number of pressure treatment facilities using ACQ is increasing. In the western United States, the ACQ-B formulation is used because it allows better penetration in difficult-to-treat western species. Treating plants in the rest of the country generally use the ACQ-D formulation. Researchers are currently evaluating the performance of a secondary highway bridge constructed from ACQ-D-treated Southern Pine lumber.^[26] Use of the more recently standardized ACQ-C formulation is expected to increase in both parts of the country.

ACQ-treated wood does not contain arsenic or chromium, and thus may offer handling and environmental advantages in some applications. ACQ-treated wood contains copper, which can be of concern in aquatic environments. The release and environmental impact of copper from ACQ-B-treated wood was recently evaluated in a wetland boardwalk study.^[23] Soil and sediment samples removed from within a few feet of the boardwalk did contain elevated levels of copper, but there was no measurable impact on either the number or diversity of aquatic invertebrates adjacent to the structure. Specific standards or BMPs for fixation of ACQ are not yet available, although it is likely that the BMPs developed for ACZA (see below) could be applied to wood treated with ACQ-B.

Ammoniacal Copper Zinc Arsenate (ACZA)—Ammoniacal copper zinc arsenate (ACZA) contains copper oxide (50 percent), zinc oxide (25 percent), and arsenic pentoxide (25 percent). ACZA is a refinement of an earlier formulation, ACA, that is no longer available in the United States. The color of the treated wood varies from olive to bluish green. The wood may have a slight ammonia odor until it is thoroughly dried after treatment. ACZA is an established preservative that protects wood from decay and insect attack in a wide range of exposures and applications. It has also protected stakes and posts placed in ground contact in exposure tests. ACZA is listed in AWWPA standards for treating a range of softwood and hardwood species and wood products. The minimum ACZA retention is 4.0 or 6.4 kg/m³ (0.25 and 0.4 lb/ft³) for wood used above ground or in ground contact, respectively. A slightly higher retention (9.6 kg/m³ or 0.6 lb/ft³) is required for wood used in highway construction and for critical structural components used in high decay hazard exposures. The ammonia in the treating solution, in combination with processing techniques such as steaming and extended pressure periods, allow ACZA to obtain better penetration of difficult-to-treat wood species than many other water-based wood preservatives. ACZA is

frequently used in the western United States for treating the Douglas Fir lumber and timbers used in construction of secondary highway bridges, trail bridges, and boardwalks. The ACZA treatment can accelerate corrosion in comparison to untreated wood, requiring the use of hot-dipped galvanized or stainless steel fasteners. Treatment facilities using ACZA are currently located in western States, where many of the native tree species are difficult to treat with CCA.

ACZA does contain inorganic arsenic, and is classified as a restricted-use pesticide by the EPA. Producers of treated wood, in cooperation with the EPA, have created Consumer Information Sheets (CIS) that give guidance on appropriate handling and use site precautions for wood treated with inorganic arsenic. These CIS should be made available to all personnel involved in handling ACZA-treated wood. The CIS limitations on the uses of ACZA-treated wood do not affect covered bridges. The environmental impact of ACZA-treated wood in sensitive environments has been evaluated. One study found that soil and sediment samples removed from directly under a large ACZA-treated elevated walkway had elevated levels of copper, zinc, and arsenic.^[23] However, samples removed at greater distances were not elevated, and there was no detectable impact on either the number or diversity of aquatic invertebrates adjacent to the structure. Another study found only occasional elevated samples, even immediately under the dripline of a wetland boardwalk.^[26]

As with all water-based preservatives, the safety and environmental compatibility of the treated wood depends on completion of fixation reactions to reduce the solubility of preservative components. In ACZA, the copper and zinc are solubilized by the ammonia in the treating solution, and become insoluble as the ammonia volatilizes from the wood. As the copper and zinc precipitate, they form insoluble zinc arsenates or copper arsenates within the wood. Wood treated with ACZA should not be exposed to precipitation or other sources of environmental moisture until this fixation process is complete. The WWPI has developed BMP processing guidelines to help ensure that ACZA-treated wood is fixed before it leaves the treating plant. These BMPs specify that the treated wood either be air dried for three weeks at a temperature above 16°C (60°F) or kiln dried to below 30 percent moisture content. The air drying time may be shortened if an in-cylinder ammonia removal step is incorporated into the treatment cycle. If the wood arrives at the job site appearing heavy, wet, and with a strong ammonia odor, it may not be thoroughly fixed. Fixation can be ensured by sticking the material and placing it in an area with good air flow. Although the wood should be covered to protect it from precipitation, it should not be covered in a way that impedes air circulation until after it has dried and the ammonia odor has dissipated.

Chromated Copper Arsenate (CCA)—Chromated copper arsenate (CCA) is the most commonly used of all wood preservatives, and until very recently represented more than 90 percent of the sales of waterborne wood preservatives. CCA-treated wood is commonly sold at retail lumber yards as green-treated wood, although most residential applications were withdrawn from the market at the end of 2003. However, it will still be allowed in nonresidential applications such as highway construction. CCA-treated wood has no odor, and as suggested by its common name, a light green color. However, it is often sold with commercially applied dyes or stains to give the wood more of a brown appearance. There are three standardized formulations of CCA: CCA Type A, CCA Type B, and CCA Type C. However, CCA Type C (CCA-C) is the formulation used by nearly all treating facilities because of its leach resistance and demonstrated efficacy. CCA-C is comprised of 47.5 percent chromium trioxide, 18.5 percent copper oxide, and 34.0 percent arsenic pentoxide dissolved in water. CCA-C has decades of proven performance in field trials and in-service applications. In accelerated testing, it is the reference preservative used to evaluate the performance of other waterborne wood preservatives. Because it has been so widely used for many years, CCA-C is listed in AWWPA standards for a wide range of wood products and applications. The minimum retention of CCA-C in the wood is 4.0, 6.4, or 9.6 kg/m³ (0.25, 0.40, or 0.60 lbs/ft³) for above ground, ground contact, and critical structural applications, respectively. As with ACC, it may be difficult to obtain adequate penetration of CCA in some difficult-to-treat wood species. Temperature limitations during treatment and rapid reaction of chromium within the wood structure can hinder penetration during longer pressure periods. However, the chromium does serve as a corrosion inhibitor, and corrosion of fasteners in CCA-treated wood is not as much a concern as it can be with some of the chromium-free alternative preservatives. Treating facilities that use CCA are widespread within the United States, making it the most readily available of all preservatives.

CCA does contain inorganic arsenic, and is classified as a restricted-use pesticide by the EPA. Producers of treated wood, in cooperation with the EPA, have created CIS that give guidance on appropriate handling and use site precautions for wood treated with inorganic arsenic. These CIS should be made available to all personnel involved in handling CCA-treated wood. The CIS limitations placed on the uses of CCA-treated wood do not impact covered bridges. The environmental impact of CCA-treated wood has been evaluated in two timber bridges in Florida.^[25] In some cases, samples removed from under the bridge did have evaluated levels of copper or chromium or arsenic, but there was no detectable effect on aquatic invertebrate populations. Similar results were found in an evaluation of the environmental impact of CCA-treated wood used in construction of a wetland boardwalk.^[23] CCA may offer an advantage over the newer alternative preservatives for use in aquatic environments, because the treated wood contains and leaches less copper. Although arsenic raises concerns as a toxin for mammals, copper may be more of a concern for fish and aquatic invertebrates.^[23]

As with other water-based preservatives, the risk of chemical exposure from CCA-treated wood is minimized after chemical fixation reactions to lock the chemical in the wood. The CCA treating solution contains hexavalent chromium, but the chromium reduces to the less toxic trivalent state within the wood. This process of chromium reduction is also critical in fixing the arsenic and copper in the wood, and CCA-treated wood should not be exposed to precipitation or other sources of environmental moisture until this fixation process is complete or nearly complete. The rate of fixation of CCA is highly temperature-dependent, requiring only a few hours at 66°C (150°F), but weeks or even months at temperatures below 16°C (60°F). Because of this temperature relationship, some treating facilities use kilns, steam, or hot water baths to accelerate fixation. An AWWPA test method, the chromotropic acid test, can be used to determine if fixation in CCA-treated wood is complete.^[20] There is some concern that the chromotropic acid test may be overly conservative because it requires more than 99.5 percent of the chromium to be reduced to the trivalent form. However, it is currently the only standardized test available, and is specified in the BMPs developed by the WWPI.^[21]

Copper Azole (CBA and CA-B)—Copper azole is another recently developed preservative formulation that relies primarily on amine copper, but with cobiocides, to protect wood from decay and insect attack. The first copper azole formulation developed was copper azole-Type A (CBA-A), which contains 49 percent copper, 49 percent boric acid, and 2 percent tebuconazole. More recently, the copper azole-Type B (CA-B) formulation was standardized. CA-B does not contain boric acid, and is comprised of 96 percent copper and 4 percent Tebuconazole. Wood treated with either copper azole formulation has a greenish-brown color and little or no odor. The copper azole formulations have been evaluated with in-ground stake tests and found to protect wood against attack by decay fungi and insects. The formulations are listed in AWWPA standards for treatment of a range of softwood species. Minimum retentions of CBA-A in the wood are 5.28, 6.56, or 9.76 kg/m³ (3.3, 0.41, or 0.61 lb/ft³) for wood used above ground, in ground contact, or in critical structural components, respectively. Minimum retentions of CA-B in the wood are 1.6, 3.2, or 4.96 kg/m³ (0.10, 0.21, or 0.31 lb/ft³) for wood used above ground, in ground contact, or in critical structural components, respectively. Although listed as an amine formulation, copper azole may also be formulated with an amine-ammonia formulation. The ammonia may be included when the copper azole formulations are used to treat refractory species, and the ability of such a formulation to adequately treat Douglas Fir has been demonstrated. The inclusion of the ammonia, however, is likely to have slight effects on the surface appearance and initial odor of the treated wood. The copper azole treatments do increase the rate of corrosion of metal fasteners relative to untreated wood, and hot-dipped galvanized or stainless steel fasteners are recommended. Because copper azole has been developed only recently, relatively few treating facilities are currently using this preservative.

The copper azole formulations do not contain arsenic or chromium, and thus may offer environmental or safety advantages in some applications. Copper azole-treated wood does contain copper, which can be of concern in aquatic environments. Proper handling and post-treatment conditioning of copper azole-treated wood is important to ensure that leaching and potential environmental impacts are minimized. The copper is solubilized in the treating solution by the presence of the amine (and in some cases ammonia). The mechanism of copper fixation in the wood is not completely understood, but appears to be strongly influenced by time, temperature, and retention. Copper fixation in the CBA-A formulation is extremely rapid (within 24 hours) at the lowest retention 3.36 kg/m³ (0.21 lb/ft³), but slows considerably at

the higher retentions unless heat is used to accelerate the fixation. As with other waterborne preservative formulations, the treated wood should not be exposed to precipitation or other sources of water until these fixation reactions are complete. Specific standards or BMPs for fixation of copper azole are not yet available.

Oil-Type Preservatives

Coal-Tar Creosote—Coal-tar creosote is the oldest wood preservative still in commercial use in the United States. It is made by distilling the coal tar that is obtained after high-temperature carbonization of coal. Unlike the other oil-type preservatives, creosote is not usually dissolved in oil, but it does have properties that make it look and feel oily. Creosote contains a chemically complex mixture of organic molecules, most of which are polycyclic aromatic hydrocarbons (PAHs). The composition of creosote depends on the method of distillation and is somewhat variable. However, the small differences in composition within modern creosotes do not affect its performance as a wood preservative. Creosote-treated wood has a dark brown to black color and a noticeable odor, which some people consider unpleasant. It is very difficult to paint creosote-treated wood. Workers sometimes object to creosote-treated wood because it soils their clothes and photosensitizes the skin on contact. The treated wood sometimes also has an oily surface, and patches of creosote sometimes accumulate, creating a skin contact hazard. Because of these concerns, creosote-treated wood is often not the first choice for applications such as handrails, where there is a high probability of human contact. This is a serious consideration for members in covered bridges that are readily accessible to the public.

However, creosote-treated wood has advantages to offset concerns about its appearance and odor. It has a lengthy record of satisfactory use in a wide range of applications, and a relatively low cost. Creosote is also effective in protecting both hardwoods and softwoods, and is often thought to improve the dimensional stability of the treated wood. Creosote is listed in AWWPA standards for a wide range of wood products and wood species. Minimum creosote retentions are in the range of 80 to 128 kg/m³ (5 to 8 lb/ft³) for above-ground applications, 160 kg/m³ (10 lb/ft³) for wood used in ground contact, and 192 kg/m³ (12 lb/ft³) for wood used in critical structural applications such as highway construction. With the use of heated solutions and lengthy pressure periods, creosote can be fairly effective at penetrating even fairly difficult-to-treat wood species. Like other oil-type systems, creosote is suitable for treatment of glue-laminated members. Creosote treatment also does not accelerate, and may even inhibit, the rate of corrosion of metal fasteners relative to untreated wood. Treating facilities using creosote are widely distributed in the United States, making it one of the more readily available preservative treatments.

Creosote is classified as a restricted-use pesticide by the EPA. Producers of treated wood, in cooperation with the EPA, have created CIS that give guidance on appropriate handling and use site precautions for wood treated with creosote. These CIS should be made available to all personnel involved in handling creosote-treated wood. People are sometimes concerned that creosote-treated wood used in aquatic applications, such as bridges, may harm the environment. This concern recently was evaluated in a study of the environmental impact of two creosote-treated wooden bridges in Indiana.^[27] In each case, elevated levels of PAH were detected in sediments 1.8 to 3 m (6 to 10 ft) downstream from the bridges, and these levels approached levels of concern for one bridge. However, no significant effect on aquatic invertebrate populations was noted for that bridge. There did appear to be a reduction in the population and diversity of aquatic insects within 6 m (20 ft) downstream for the other bridge, but the author postulated that this trend was caused by the deposition of maple leaves in this area.

As with other preservatives, the environmental impact of creosote-treated wood is a function of treatment practices. Creosote in treated wood may sometimes bleed or ooze to the surface and drip to surfaces or the water below. This problem may be apparent immediately after treatment, and such members should not be used in bridges or other aquatic applications. However, in other cases, the problem does not become obvious until after the product is placed in service in a location where it is exposed to direct sunlight. This problem is best addressed through the control of treatment processes and BMPs. The WWPI's BMPs for creosote-treated wood call for the use of either an expansion bath or final steaming at the end of the pressure period:

- Expansion Bath: Following the pressure period, the creosote should be heated -12.2 to -6.6°C (10-20°F) above press temperatures for a minimum of 1 hour. Pump creosote back to storage and apply a minimum vacuum of 609 mm (24 inches) for a minimum of 2 hours.
- Steaming: Following the pressure period and after the creosote has been pumped back to the storage tank, a vacuum shall be applied for a minimum of 2 hours at not less than 559 mm (22 inches) of vacuum to recover excess preservative. Release vacuum back to atmospheric pressure and steam for a 2-hour period for lumber and timbers, and 3 hours for piling. Maximum temperature during this process shall not exceed 115.5°C (240°F). Apply a second vacuum for a minimum of 4 hours at 559 mm (22 inches) of vacuum.

Pentachlorophenol in Heavy Oil—Pentachlorophenol has been widely used as a pressure treatment preservative in the United States since the 1940s. The active ingredients, chlorinated phenols, are crystalline solids that can be dissolved in different types of organic solvents. The performance of pentachlorophenol and the properties of the treated wood are influenced by the properties of the solvent. The heavy oil solvent, as specified in AWWA Standard P9, Type A, is preferable when the treated wood is to be used in ground contact, as wood treated with lighter solvents may not be as durable. Wood treated with pentachlorophenol in heavy oil typically has a brown color, and may have a slightly oily surface that is difficult to paint. It also has some odor, which is associated with the solvent. Like creosote, pentachlorophenol in heavy oil should not be used in applications where there is likely to be frequent contact with skin (i.e., handrails). Pentachlorophenol in heavy oil has long been a popular choice for treatment of utility poles, bridge timbers, and glue-laminated beams and foundation piling, and has established its efficacy as a wood preservative. Like creosote, it is effective in protecting both hardwoods and softwoods, and is often thought to improve the dimensional stability of the treated wood. Pentachlorophenol is listed in AWWA standards for a wide range of wood products and wood species. The minimum softwood retentions are 6.4 kg/m³ (0.4 lb/ft³) for wood used above ground or in ground contact, and 8.0 kg/m³ (0.5 lb/ft³) for wood used in severe decay hazard exposures or critical structural applications. Slightly lower minimum retentions 4.0 or 4.8 kg/m³ (0.25 to 0.3 lb/ft³) are specified for treatment of red oak. With the use of heated solutions and extended pressure periods, pentachlorophenol is fairly effective at penetrating difficult-to-treat species. It does not accelerate corrosion of metal fasteners relative to untreated wood, and the heavy oil solvent helps to impart some water repellence to the treated wood. Treating facilities in many areas of the United States use pentachlorophenol in heavy oil, making it one of the most readily available wood preservatives.

Pentachlorophenol is classified as a restricted-use pesticide by the EPA. Producers of treated wood, in cooperation with the EPA, have created CIS that give guidance on appropriate handling and use-site precautions for wood treated with pentachlorophenol. These CIS should be made available to all personnel involved in handling pentachlorophenol-treated wood. People are sometimes concerned that pentachlorophenol-treated wood used in aquatic applications, such as bridges, may harm the environment. To evaluate this concern, Brooks evaluated the environmental impact of two pentachlorophenol-treated bridges in Washington and Oregon.^[25] Sediment concentrations of pentachlorophenol were near or below detection limits at the bridge in Washington State, and well below levels of concern. Slightly elevated levels of pentachlorophenol were detected in four sediment samples removed under or downstream from the Oregon bridge, and a small decrease in several biological indices was also noted. However, these changes appeared to be caused by differences in the stream bottom habitat relative to the upstream control.

As with other preservatives, the environmental impact of pentachlorophenol-treated wood is a function of treatment practices. When used with a heavy oil solvent, pentachlorophenol-treated wood may have bleeding or surface oil problems similar to that described for creosote. Any member that has an excessively oily surface or is bleeding pentachlorophenol should not be used. Treatment procedures that are likely to minimize bleeding after the member is placed in service should also be specified. The BMPs developed by WWPI for pentachlorophenol treatment stress thorough drying of the wood before treatment and the use of an empty cell treatment process. In an empty cell process, the air pressure is applied to the wood before the preservative is introduced to the treatment cylinder. Following the pressure period, a

final vacuum should be incorporated, as well as either a final steaming or expansion bath similar to that described for creosote treatments.

Copper Naphthenate—The preservative efficacy of copper naphthenate has been known since the early 1900s, and various formulations have been used commercially since the 1940s. It is an organometallic compound formed as a reaction product of copper salts and petroleum-derived naphthenic acids. Copper naphthenate is somewhat unique among commercially applied wood preservatives in that preservative solution can be purchased in small quantities at retail hardware stores and lumberyards. It is often recommended for field treatment of cut ends and drill holes made during construction with pressure-treated wood. Copper naphthenate-treated wood initially has a distinctive bright green color that weathers to light brown. The treated wood also has an odor that dissipates somewhat over time. Depending on the solvent used and treatment procedures, it may be possible to paint copper naphthenate-treated wood after it has been allowed to weather for a few weeks. Like pentachlorophenol, copper naphthenate can be dissolved in a variety of solvents. The heavy oil solvent, as specified in AWPA Standard P9, Type A, or the lighter solvent AWPA Standard P9, Type C are the most commonly used solvents. Although not as widely standardized as creosote and pentachlorophenol treatments, copper naphthenate is listed in AWPA standards for treating major softwood species used for a variety of wood products. It is not listed for treatment of any hardwood species. The minimum copper naphthenate retentions (as elemental copper) range from 0.64 kg/m³ (0.04 lb/ft³) for wood used above ground, to 0.96 kg/m³ (0.06 lb/ft³) for wood used in ground contact, and 1.2 kg/m³ (0.075 lb/ft³) for wood used in critical structural applications. When dissolved in #2 fuel oil, copper naphthenate is able to adequately penetrate many difficult-to-treat wood species. Some of this penetration ability is lost when dissolved in heavier oils. Copper naphthenate treatments do not significantly increase corrosion of metal fasteners relative to untreated wood. Copper naphthenate is most commonly used in the treatment of utility poles, although facilities utilizing copper naphthenate are not as widely distributed as those producing wood treated with creosote or pentachlorophenol.

Copper naphthenate, unlike creosote and pentachlorophenol, is not listed as a restricted-use pesticide by the EPA. The lesser human health concerns associated with copper naphthenate are also evidenced by the availability of the preservative solution for retail purchase. However, precautions such as the use of dust masks and gloves should still be used when working with copper naphthenate-treated wood. Because of its more limited use and relatively lower toxicity when compared to creosote or pentachlorophenol treatments, there has been relatively little study of copper naphthenate's potential environmental impacts, especially in aquatic environments. Some leaching may occur, as evidenced by the detection of elevated copper levels in soil samples removed from within 0.3 m (12 inches) of Douglas Fir utility poles in northern California.^[28] However, much less copper was detected in soil adjacent to Southern Pine utility poles in Alabama, suggesting that species differences, treatment practices, or site differences influenced leaching. It is known that treatment practices can influence leaching in a manner similar to other oil-type preservatives. In their study, Harp and Grove noted that several of the Douglas Fir utility poles had been repeatedly returned to the treater for surface treatments after complaints about the oily surface. However, those treatments used a heavy oil solvent, and surface oils appear to be less of a problem when #2 fuel oil is used as the solvent. The importance of using treatment practices to minimize environmental concerns associated with copper naphthenate-treated wood is also recognized by the WWPI, which has developed BMPs for production of copper naphthenate-treated wood used in aquatic environments. The recommended treatment practices for treatment in heavy oil include using an expansion bath and/or final steaming similar to that described above for creosote. When #2 fuel oil is used as the solvent, the BMPs recommend using a final vacuum for a minimum of 1 hour.

Chlorothalonil (CTL) in Heavy Oil—Chlorothalonil (CTL) has been used for decades as a broad-spectrum agricultural fungicide. More recently, it has been proposed for use as an oil-based wood preservative comprised of approximately 96 percent tetrachloroisophthalonitrile. CTL is colorless, but the appearance of the treated wood will be dependent on the solvent used. When used in heavy oil solvent, as described in AWPA Standard P9, Type A, the treated wood will have a brown color and may have a slightly oily surface that is difficult to paint. CTL was included in AWPA standards fairly recently as a potential alternative to treatment with pentachlorophenol. However, it has not yet been standardized for use with any wood product or type of exposure, and no minimum retentions are listed. However, based on

exposure of field stakes, it appears that chlorothalonil is effective at protecting wood in ground contact when used at a retention of 4.48 kg/m³ (0.28 lb/ft³) or greater. CTL has primarily been evaluated for use in protection of softwood species. Availability of CTL is limited. At this time, there are no commercial treatment facilities using CTL.

One of the characteristics of chlorothalonil that has made it attractive as an agricultural pesticide is its relatively low acute toxicity to humans and other mammals. However, precautions such as the use of dust masks and gloves should still be used when working with chlorothalonil-treated wood. The environmental impact of chlorothalonil-treated wood in service has not been evaluated. CTL is relatively nontoxic for birds, but is toxic to fish and aquatic invertebrates. It is moderately persistent in the environment, with a soil half-life of 1 to 3 months. CTL has very low water solubility, which helps to reduce leaching from the treated wood. However, when treated in heavy oil, there is potential for loss of CTL into the environment if the oil moves out of the wood. Best-management treatment practices similar to those described for pentachlorophenol should be used to reduce or minimize bleeding of the oil to the wood surface.

Preservatives That are Effective Above Ground, Fully Exposed to the Weather

The preservatives listed in this section generally do not provide long-term protection for wood exposed in direct contact with soil or standing water, but are effective in preventing attack in wood exposed above the ground, even if it is directly exposed to rainfall. Examples of these applications in covered bridges include weatherboarding and any above-ground portion of the bridge that extends beyond the protective cover of the roof. The preservatives listed in the previous section also perform well in these applications, and can be used at their lower, above-ground retentions. Some above-ground applications that retain moisture and/or collect organic debris may present a deterioration hazard similar to ground contact. Preservatives discussed above may be more appropriate for such applications, especially in critical structural members.

Oilborne Preservatives

Oxine Copper (Copper-8-quinolinolate)—Oxine copper is an organometallic preservative comprised of 10 percent copper-8-quinolinolate and 10 percent nickel-2-ethylhexoate. It is characterized by its low mammalian toxicity, and is permitted by the U.S. Food and Drug Administration for treatment of wood used in direct contact with food. The treated wood has a greenish brown color, and little or no odor. It can be dissolved in a range of hydrocarbon solvents, but provides much longer protection when delivered in heavy oil. Oxine copper is listed in AWPA standards for treatment of several softwood species used in exposed, above-ground applications. The minimum specified retention for these applications is 0.32 kg/m³ (0.02 lb/ft³) (as elemental copper). Oxine copper solutions are somewhat heat sensitive, which limits the use of heat to increase preservative penetration. However, adequate penetration of difficult-to-treat species can still be achieved, and oxine copper is sometimes used for treatment of the above-ground portions of Douglas Fir used in wooden bridges and deck railings. Oilborne oxine copper does not accelerate corrosion of metal fasteners relative to untreated wood. Oxine copper is not widely used by pressure-treatment facilities, but is currently available from at least one plant on the West Coast.

Oxine copper-treated wood presents fewer toxicity or safety and handling concerns than the oilborne preservatives that can be used in ground contact. It is also sometimes used as an anti-sapstain preservative or incorporated into retail stains for siding, shingles, and log cabins. However, precautions such as wearing gloves and dust masks should be used when working with the treated wood. Because of its somewhat limited use and low mammalian toxicity, there has been little research to assess the environmental impact of oxine copper-treated wood used in sensitive environments. However, it is an oilborne preservative, and can be susceptible to bleeding or oozing from the treated wood under certain conditions. There are no specific standards or BMPs for oxine copper-treated wood, but some of the same treatment practices used for other oilborne preservatives could apply. Although heating concerns may limit the use of expansion baths, other techniques such as empty cell treatments and final vacuum can be employed.

Pentachlorophenol in Light Solvent—As discussed above, the performance of pentachlorophenol and the properties of the treated wood are influenced by the properties of the solvent. Pentachlorophenol is most

effective when applied with a heavy solvent, but it performs very well in lighter solvents for above-ground applications. Lighter solvents also provide the advantage of a less oily surface appearance, lighter color, and improved paintability. Above-ground minimum retentions for pentachlorophenol vary from 4.0-4.8 kg/m³ (0.25-0.3 lb/ft³) for treatment of red oak to 6.4 kg/m³ (0.4 lb/ft³) for softwood species. Pentachlorophenol in light oil has some similarities to heavy oil. It can be used to treat relatively refractory wood species, and it does not accelerate corrosion. However, one disadvantage of the lighter oil is that less water repellence is imparted to the wood. Treatment facilities using pentachlorophenol in light oil are also not as numerous as those using light oil.

Although pentachlorophenol in light oil provides a clean, dry surface, the same active ingredient is present, and it is still classified as a restricted-use pesticide by the EPA. Precautions on the CIS still apply, and these CIS should be made available to all personnel involved in handling pentachlorophenol-treated wood. However, bleeding of preservative to the surface of the wood is less likely to occur with the lighter oil, reducing concerns about environmental or human exposure.

Preservatives That are Effective Above Ground with Partial Exposure and Occasional Wetting

The preservatives listed in this section have not demonstrated the ability to provide long-term protection against a broad range of decay organisms in high-decay hazard applications. However, they do adequately protect wood that is above ground and occasionally exposed to wetting. Examples of these applications in a covered bridge include members near the ends of the bridge that may be subjected to wetting from wind-blown rain or from splashing during heavy rainfall. Some above-ground applications that retain moisture and/or collect organic debris may present a more severe deterioration hazard, and a preservative from one of the previously discussed sections would then be more appropriate.

Water-Based Preservatives

Didecyldimethylammonium Chloride (DDAC)—Didecyldimethylammonium chloride (DDAC) is one of several quaternary ammonium compounds that are widely used as bactericides, antiseptics, and fungicides. DDAC is the quat component of the wood preservatives ACQ-D and ACQ-B, and is also a component of antispain formulations. It is colorless, nearly odorless, and can be formulated for use with either water- or oil-based carriers, although solvency is diminished in lighter aliphatic hydrocarbons such as mineral spirits. DDAC is listed as a preservative in AWP standards, but has not been standardized for pressure treatment with any specific wood product or exposure environment. Its current pressure treatment use is as a cobioicide to protect wood treated with copper-based preservatives against attack by copper tolerant fungi. Soil block tests indicate that a DDAC retention of 6.4 kg/m³ (0.4 lb/ft³) is sufficient to protect wood from attack by brown and white rot fungi. Slightly higher retentions may be needed to protect hardwoods from attack by soft-rot fungi, but most covered bridge applications do not have sufficient moisture to sustain soft-rot attack. Lower retentions would probably be sufficient to protect wood used in above-ground, partially protected applications. There are currently no pressure treatment facilities using DDAC as a stand-alone preservative.

DDAC has low mammalian toxicity, as evidenced by its use as a preservative or disinfectant in various consumer products. However, workers handling wood treated with DDAC should use standard precautions such as wearing dust masks and gloves. The environmental impacts of DDAC in treated wood have been investigated to some extent. Although environmental levels of DDAC were not quantified, an evaluation of the environmental impact of wetland boardwalk treated with ACQ-B found no impact on aquatic invertebrates at the site. The DDAC appears to react, or fix, with wood during and within a few days after treatment, becoming resistant to leaching. However, some leaching of DDAC from treated wood does occur. One study found that 12-25 percent of DDAC was lost from the outer 12.7 mm (0.5 inches) of Southern Pine posts exposed in Florida for 18 months.^[29] However, lower leaching rates would be expected from wood exposed above ground and partially protected from precipitation. DDAC is moderately to very toxic to fish and other aquatic organisms. After it is released into the environment, it appears to be relatively resistant to degradation in water, but is readily decomposed by bacteria in soil and sediments. Because it reacts readily with organic matter in soil and sediment, its environmental

mobility is limited. There are currently no standards or BMPs for methods of minimizing leaching of DDAC from treated wood, but allowing the wood to dry may increase leach resistance.

Oil-Type Preservatives

Isothiazolone (DCOI)—Isothiazolones are a class of organic compounds that have shown some promise for use in wood preservatives. One of these compounds, 4,5-dichloro-2-N-octyl-4-isothiazolin-3-one (DCOI), has been evaluated fairly extensively. DCOI is currently used as a marine antifouling agent in paint films.^[30] DCOI has demonstrated sufficient potential as a wood preservative to be listed in AWWA standards, but has not yet been standardized for use with any wood product or exposure environment. Thus, there are no minimum retentions given for this preservative. However, research indicates that it is quite effective in protecting wood used above ground when treated to a retention of 1.6 kg/m³ (0.1 lb/ft³) or greater. As with other oil-soluble preservatives, the properties of wood treated with DCOI will somewhat depend on the type of solvent used. Current standards call for the use of light oil solvent (AWWA Standard P9, Type C), which should leave the wood with a relatively dry surface, and may allow subsequent finishing. The treatment may impart a light brown color to the wood. DCOI does have a noticeable odor, and the treated wood may have some odor, depending on the concentration of the treating solution. Availability is a limitation of DCOI, as no treatment facilities are currently using this preservative.

DCOI is not listed as an EPA restricted-use pesticide, and has lower acute toxicity than the restricted-use pesticide preservatives. However, DCOI-treated wood should still be handled carefully, and gloves and dust masks should be used when working with the treated wood. The environmental impact of DCOI-treated wood has not been evaluated, but the molecule does decompose rapidly in sediments or water. The rate of leaching of DCOI from treated wood appears to be somewhat greater than for other preservatives, including pentachlorophenol dissolved in a similar solvent. There currently are no best management practices or similar guidelines for treatment practices to minimize leaching from wood treated with DCOI.

3-Iodo-2-proponyl carbamate (IPBC)—3-Iodo-2-proponyl carbamate (IPBC) is commonly used as an ingredient in antisapstain formulations, or as a fungicide in water-repellent finishes for decks or siding. It is also used to treat millwork. Although described here as an oil-soluble preservative, water-based formulations may also be used. IPBC is colorless, and depending on the solvent and formulation, the treated wood may be paintable. Some formulations may have noticeable odor, but formulations with little or no odor are also possible. IPBC is not an effective insecticide, and is not used as a stand-alone treatment for critical structural members. In above-ground, weather-protected applications, it is used in pressure treatment when combined with an insecticide such as chlorpyrifos. IPBC is listed as a preservative in AWWA standards, but has not been standardized for pressure treatment of any exposure condition or wood product. However, it was recently standardized for dip treatment of ponderosa pine millwork at a minimum retention of 950 ppm (approximately 0.368 kg/m³ (0.023 lb/ft³)), and soil block tests indicate that IPBC is effective in preventing fungal attack of both hardwoods and softwoods when used at a retention of 0.352 kg/m³ (0.022 lb/ft³) or higher. After nine years, above-ground exposure tests with pressure-treated Douglas Fir, Ponderosa Pine, and Western Hemlock indicate that mixtures of IPBC and chlorpyrifos can protect wood from decay at IPBC retentions as low as 0.8 kg/m³ (0.05 lb/ft³). Although not a standardized treatment, some pressure-treating facilities use a mixture of IPBC and chlorpyrifos to treat structural members that are to be used above ground, and that are largely protected from the weather. These facilities are using IPBC retentions of 0.56 kg/m³ (0.035 lb/ft³) or higher, with mineral spirits as the solvent. The advantage of this treatment is that it is colorless and allows the wood to maintain its natural appearance. This treatment is being used on relatively refractory western species. In general however, the number of facilities conducting pressure treatments with IPBC is very limited.

IPBC has relatively low acute toxicity for mammals, and is not classified as an EPA restricted-use pesticide. However, standard precautions such as wearing gloves and dust masks should still be followed when working with wood treated with IPBC. Because it typically has not been used for pressure treatment, there has been little evaluation of the environmental impact of wood treated with IPBC. However, it appears that IPBC is nonpersistent in the environment, degrading rapidly in soil and aquatic

environments. It has low toxicity for birds, but is highly toxic to fish and aquatic invertebrates. The relatively low IPBC concentrations used in the wood and its rapid degradation in the environment would be expected to limit any environmental accumulations caused by leaching. Because IPBC usually is used with a light solvent, bleeding or oozing of the preservative out of the wood is unlikely.

Tributyltin oxide (TBTO™)—Bis(tri-n-butyltin) oxide (TBTO) is a colorless to slightly yellow liquid preservative that is soluble in organic solvents, but not soluble in water. It has been used extensively as an antifouling agent in marine paints, as a preservative in finishes, and in dip treatments for wood used in millwork. It is listed as a wood preservative in AWWA standards, where it is specified for use with a light hydrocarbon solvent (AWWA Standard P9, Type C). When used in a light solvent, wood treated with TBTO is paintable and has little odor. At this time, TBTO is not listed in AWWA standards for pressure treatment of any wood product for any exposure environment. Used alone, TBTO is not effective in protecting wood that is placed in ground contact, but data indicate that it may be effective in protecting wood products that are used above ground, and partially exposed to the weather. For softwoods, minimum retentions of 0.96 kg/m³ (0.06 lb/ft³) have been proposed for control of decay fungi, while at least 0.120 kg/m³ (0.075 lb/ft³) of TBTO is needed to impart insect resistance. Most evaluations have been conducted with softwood species, and it is less certain that these retentions will be effective in protecting hardwood species.

Although less toxic than some wood preservative ingredients, TBTO is moderately to acutely toxic to mammals, and can depress the immune system. Workers handling wood treated with TBTO should use precautions such as wearing gloves and dust masks. TBTO has not been used as a stand-alone pressure treatment wood preservative, and there are no studies of the environmental effects of using TBTO-treated wood in sensitive environments. TBTO can be highly toxic to some aquatic organisms, and these concerns have led to limitations on its use in marine antifouling paints. It has low water solubility, and is readily adsorbed on particles, so it tends to be removed from the water column relatively quickly. However, it may persist in sediments for several years. The amount of TBTO leached from treated wood in a covered bridge application would probably be low because of the partial protection from precipitation, and because relatively low retentions are used in treatment. There are currently no standards or best management practices for minimizing TBTO leaching, but bleeding or oozing of the preservative should not be a problem when the wood is treated using a light solvent.

Propiconazole (PPZ)—Propiconazole (PPZ) is a light-to-dark yellow, clear liquid that contains a fungicidal triazole compound. PPZ is not soluble in water, but is soluble in light organic solvent. Wood treated in this manner has little color and is paintable. PPZ is commonly used as a systemic fungicide to combat plant diseases, and sometimes as a component of antisapstain formulations. It is not very effective at preventing attack by wood-destroying insects, and may need to be used in combination with an insecticide, such as chlorpyrifos. Propiconazole is listed as a wood preservative in AWWA standards, but is not standardized for pressure treatment of any wood product or exposure application. PPZ is not effective in protecting wood placed in ground contact, but it has been proposed as a dip treatment for wood used in partially protected above-ground exposures. The minimum retention proposed for dip treatments is approximately 4.96 kg/m³ (0.31 lb/ft³). Most of the efficacy data for PPZ was obtained using softwoods, and the retentions needed to protect hardwoods are less clear. Currently there are no pressure treatment facilities utilizing PPZ as a stand-alone preservative treatment.

PPZ has relatively low mammalian toxicity, but workers handling wood treated with PPZ should still follow precautions such as wearing gloves and dust masks. The environmental impact of PPZ-treated wood used in sensitive environments has not been evaluated. Because of its low water solubility, PPZ is not highly leachable, and it is only slightly to moderately toxic to fish. It breaks down fairly rapidly in water and soil, and has limited mobility in soil. The USFS uses it as a fungicide, although care must be taken to avoid spraying PPZ near water.

Tebuconazole (TEB)—Tebuconazole is a triazole-based fungicide that is commonly used to control plant diseases, and is also incorporated into wood preservative formulations. Although included here as an oil-based preservative, it can also be formulated to be compatible with waterborne preservatives. For example, tebuconazole is added to the waterborne preservative copper azole (see above) to improve the

formulation's performance against copper-tolerant fungi. Tebuconazole is listed as a wood preservative in AWWPA standards, but is not specified as a stand-alone pressure treatment preservative for any wood product or exposure application. It is specified for use with light organic solvent, which should render the treated wood colorless and paintable. Although not standardized as a stand-alone preservative, it appears that Tebuconazole has potential to protect wood that is exposed above ground and partially protected from weathering. When incorporated with a water repellent, it appears to work effectively above ground in preventing attack by brown rot fungi, even at retentions as low as 0.16 to 0.48 kg/m³ (0.01 to 0.03 lb/ft³), but there is insufficient long-term data to confirm this efficacy. Retentions needed to protect against soft-rot attack would probably be greater, and an insecticide such as chlorpyrifos would be needed in areas where insect attack may be a concern. There currently are no pressure treatment facilities in the United States that use tebuconazole as a stand-alone wood preservative.

Tebuconazole has relatively low mammalian toxicity, but workers handling wood treated with this preservative should use standard precautions such as wearing gloves and dust masks. The environmental impact of wood pressure treated with tebuconazole has not been evaluated, but it appears that tebuconazole is fairly leach-resistant. At the low retentions used, and when partially protected from precipitation, the amounts of tebuconazole entering the environment are expected to be quite low.

Zinc Naphthenate—Zinc naphthenate is used extensively as a component in over-the-counter wood preservative products. It can be formulated as either a solvent-borne or waterborne preservative. Unlike copper naphthenate, zinc naphthenate imparts little color to the wood, and thus is more compatible with finishes. When formulated in light solvent, the treated wood may also be paintable. However, wood treated with zinc naphthenate may have a noticeable odor. Zinc is not nearly as effective a fungicide as copper, and zinc naphthenate is not used as a stand-alone preservative for exposed structural members. Zinc naphthenate is not listed as a wood preservative in AWWPA standards. However, zinc naphthenate does have some preservative efficacy, and may be sufficient to protect wood used above ground and partially protected from the weather. Zinc naphthenate pressure treatments have been shown to extend the life of treated stakes exposed in Mississippi, and brush treatments of a waterborne zinc naphthenate significantly improved the performance of pine fully exposed to the weather (above ground) in Mississippi. However, zinc naphthenate was less effective in protecting hardwoods in that study. Adding a water-repellent component to the treating solution appears to increase the efficacy of zinc naphthenate treatments.

Zinc naphthenate has only low to moderate mammalian toxicity. However, workers handling zinc naphthenate treated wood should use standard precautions such as wearing gloves and dust masks. There have not been any studies of the environmental effects of zinc naphthenate treated wood used in aquatic environments. Zinc naphthenate has relatively low environmental toxicity and has not been the subject of as much review as many other pesticides.

Preservatives That are Effective Above Ground, Occasionally Damp, But Protected from Liquid Water

The preservatives listed in this section are waterborne preservatives that do not fix in the wood, and thus are readily leachable. They provide adequate protection as long as the wood is not subjected to liquid water that could wash the active ingredients out of the wood. Examples of these types of applications in covered bridges are internal members that are well-protected from the weather, but may be subject to insect attack or occasionally dampened due to humidity or condensation.

Borates—Borate compounds are the most commonly used unfixed waterborne preservatives. They are used to pressure treat framing lumber used in areas of high termite hazard, and as surface treatments for a wide range of wood products such as log cabins and the interiors of wood structures. They are also applied as internal treatments via rods or pastes. At higher retentions, borates are also used as fire-retardant treatments for wood. Boron has some exceptional performance characteristics, including low mammalian toxicity and activity against fungi and insects, and it is inexpensive. Another advantage of boron is its ability to move and diffuse with water into wood that normally resists traditional pressure

treatment. In addition, wood treated with borates has no color, no odor, and can be finished. While boron has many potential applications in framing, it is probably not suitable for most components of a covered bridge, because the chemical will leach from the wood under wet conditions. It may, however, be a useful treatment for insect protection in areas continually protected from wetting. Inorganic boron is listed as a wood preservative in AWP standards, and includes formulations prepared from sodium octaborate, sodium tetraborate, sodium pentaborate, and boric acid. Inorganic boron is also standardized as a pressure treatment for a variety of species of softwood lumber used out of contact with the ground and continuously protected from liquid water. The minimum retention (as B_2O_3) is 2.72 kg/m^3 (0.17 lb/ft^3), except that 4.48 kg/m^3 (0.28 lb/ft^3) is specified for areas with Formosan subterranean termites.

Borate preservatives are available in several forms, but the most common is disodium octaborate tetrahydrate (DOT). DOT has higher water solubility than many other forms of borate, allowing the use of higher solution concentrations and increasing the mobility of the borate through the wood. With the use of heated solutions, extended pressure periods, and diffusion periods after treatment, DOT is able to penetrate relatively refractory species such as spruce. There are several pressure treatment facilities in the United States that use borate solutions to treat wood.

Although borates have low mammalian toxicity, workers handling borate-treated wood should use standard precautions such as wearing gloves and dust masks. The impact of the use of borate-treated wood for construction projects in environmentally sensitive areas has not been evaluated. Because borate-treated wood is used in areas where it is protected from precipitation or liquid water, little or no losses into the environment should occur. In addition, borates have low toxicity to birds, aquatic invertebrates, and fish, and boron salts occur naturally in the environment at relatively high levels. However, because borates are readily leachable, extra care should be taken to ensure that borate-treated wood stored at the job site is well-protected from precipitation. Exposure to precipitation could cause depletion of boron in the wood to below effective levels, and cause harm to vegetation directly below the stored wood.

Conclusions

There is a wide array of methods for limiting the risk of biodeterioration in covered bridges. Careful design to exclude water, coupled with the use of properly specified preservative-treated wood where necessary, and a regular program of maintenance and inspection can help sharply reduce losses associated with decay.

APPENDICES

Appendices A, B, and C were authored by Phillip C. Pierce, P.E., Deputy Commissioner of Public Works, Delaware County, NY. His articles have been reproduced from other sources, as noted below.

- Appendix A “Those Intriguing Town Lattice Timber Trusses”
Published in the August 2001 edition (Vol. 6, No. 3) of ASCE’s
Practice Periodical on Structural Design and Construction.
(included herein by permission)
- Appendix B “The Trials and Successes of Covered Bridge Engineering and Construction—Hamden
Covered Bridge, Delaware County, NY “
Reproduced with permission of the Transportation Research Board. In the *Transportation
Research Record: Journal of the Transportation Research Board*, No. 1792, National
Research Council, Washington, DC, 2002, pp. 44-49.
- Appendix C “Rehabilitation of Fitch’s Covered Bridge, Delaware County, NY “
The article was used for the nomination of this project for consideration for the 2002
National Timber Bridge Awards, April 2002
- Appendix D Rehabilitation and Resiting of the Brown’s River Covered Bridge, Westford, VT

Examples of New Construction

- Appendix E A Tale of Two Bridges
- Appendix F Smith Covered Bridge over the Baker River, Plymouth, NH
- Appendix G Caine Road Covered Bridge, Ashtabula County, OH

Examples of a Replica Bridge

- Appendix H Replacement of the Mill Covered Bridge, Tunbridge, VT
- Appendix I Rehabilitation of the Paper Mill Covered Bridge, Bennington, VT
- Appendix J Replacement of the Power House Covered Bridge, Johnson, VT



Figure 171. Brown Bridge, Shrewsbury, VT



Figure 172. Lower Cox Bridge, Northfield, VT

Appendix A. Those Intriguing Town Lattice Timber Trusses

Introduction

So, why do those Town lattice covered bridges still stand? This vexing question has captured the interest of some of us for a long time. This paper records the efforts of the author for the past several years on the evaluation and rehabilitation of five individual covered bridges supported by Town lattice trusses and identifies anticipated future efforts related to this mission.

Description of the Truss



Figure 173. Side view of a typical covered bridge supported by Town lattice timber trusses. This is the Fuller Bridge, Montgomery, VT, during its recent reconstruction.

Initial Town first patented this style of wooden truss in 1820 as a means of minimizing the use of complicated timber joinery. The truss is typically constructed of sawn planks, about 3 inches (75 mm) thick and 12 inches (305 mm) wide. The chord sticks may be up to 36 feet (11.0 m) long and the lattice members are often about 22 to 24 feet (6.7 to 7.3 m) long. The classic configuration of Town lattices uses pairs of chord sticks on each side of the criss-crossed web members leading to six vertical planes of truss members. The lattice members are usually inclined at about 45-50 degrees from the horizontal and are spaced at about 4'-0" (1.2 m). Commonly, the bottom of the truss contains two lines of chords, one at the lowest intersections of the lattice and one staggered above at the next line of intersections. The floor system is supported by the lowest most chord. The top of the truss usually contains two levels of chords like the bottom, although there is often only a single topmost chord.

The nature of this type of construction is such that the individual sticks are connected into a rigid truss by the use of wooden pegs ("trunnels"—today's common name and proper pronunciation of "trenails"—the more traditional term from earlier times). Each intersection of lattice is usually fastened with two trunnels in the lattice-only connections and either three or four at the chord intersections.

The classic construction, therefore, contains six vertical planes of timbers—two chords, then two lattice members, and then two more chords. Therefore, at any location along the length of the chord, there are four chord sticks. When one chord stick ends, there is no specific splice of the member, only an abrupt termination. The load that the stick supports along its length gets into/out of it via the trunnels at the intersections. Therefore, at the intersection, the remaining three chord sticks must share the load.

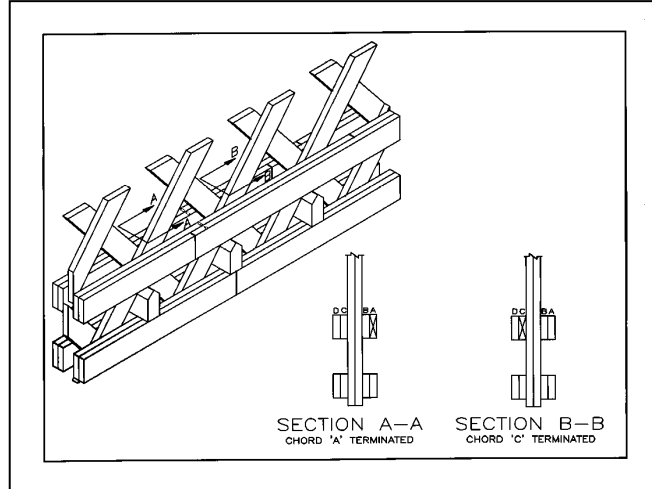

Figure 174. Depicts a portion of the bottom chords (upper and lower portions) of a Town lattice truss. The sections demonstrate the termination of one of the four chord elements at a given location along the truss.

The Problem

Ah, to the problem—how much load goes to each of the remaining three sticks?

Due to the relative stiffness of the chords and inclined lattice members, connected by wooden trunnels, it is common to assume that all load from such chord stick termination must be carried by its sister chord stick. Hence, at a termination, the sister supports 50 percent of the total chord load, while the pair of chord sticks on the opposite side of the lattice support about 25 percent each.

However, although this is very logical as a first assumption, these complex and redundant structures seem to have substantially more strength than would be indicated by this simple load distribution assumption.

To expand the confusion, each “panel” of the truss behaves slightly differently since the tensile force in individual sticks is dependent on its relationship to the other three members with respect to distance from terminations. That is, for a 20-foot- (6.1 m) long member, with five chord/lattice intersections along its length, load must get into it from the first two intersections and out of it at the last two (the middle intersection may contribute or deduct load, depending on various parameters). Since no panel typically has more than one termination, the pattern of the terminations of the four elements along the length of the bridge influences how much force any one element experiences.

Alternative Approaches

Many alternatives have been investigated in an attempt to better define the strength of these structures. During the course of an extensive evaluation of 75 covered bridges in Vermont, including 40 supported by Town lattice trusses, the writer participated in several such activities.

The first involved the development of a meticulous computer simulation using finite element software. All components of the bridge were modeled in a three-dimensional structure. The trunnel connections at each intersection were modeled as single elements with properties derived for the trunnel group, acting as a five-span continuous horizontal member connecting the six vertical planes of truss elements. A rigorous analytical exercise was undertaken to determine the vectored shear in each shear plane of all trunnels

under the influence of both dead and live (vehicular) forces—no small feat in itself! The computer simulation was “checked”, in part, by comparing the measured deflection of the structure under the influence of a vehicle of known weight with computer prediction. The results of this computer simulation indicated that the chord forces do indeed cross from one side of the lattice to the opposite pair of chords, across the lattice members, leading to individual chord stick values greater than 33 percent but generally less than 60 percent.

It must be noted that during the initial phases of this computer simulation, special testing of sample Town lattice truss connections was performed at the Remergence Laboratory of MIT. While such tests were limited in nature, they nonetheless offered additional insight into the behavior of these types of truss connections. The results of the tests provided support for the assumed capacities of the connections found in typical Town lattice trusses.

During an especially vigorous evaluation of another bridge this past summer, I became convinced that the current finite element computer simulation has not satisfactorily accounted for potential inelastic behavior of the truss connections. This conundrum is manifested in the disparity of having field measurements nearly replicate predicted structure deflections under known loading, while leading to seemingly conservative load distributions among the chord sticks.

The Latest Chapter

Now, on to the latest in this evolutionary evaluation of Town lattice trusses.

Faced with the need for major rehabilitation of another Town lattice truss owned by my employer (the Delaware County Department of Public Works), we opted for additional field testing aimed at furthering the knowledge of load distribution in the chords. Forty-six transducers were attached to the top and bottom of the lower bottom chord sticks at seven separate locations along the trusses of the bridge. Refer to figure 175. These transducers are basically strain gages that can be easily mounted to an element to measure the change in length of the element when subjected to a loading. The top and bottom pairing allowed averaging of the results to determine axial load, thereby avoiding the complications of the additional stresses from flexure due to direct support of the floor beams. The seven locations near the center of the single-span truss enabled comparisons of load sharing at different locations along the truss.

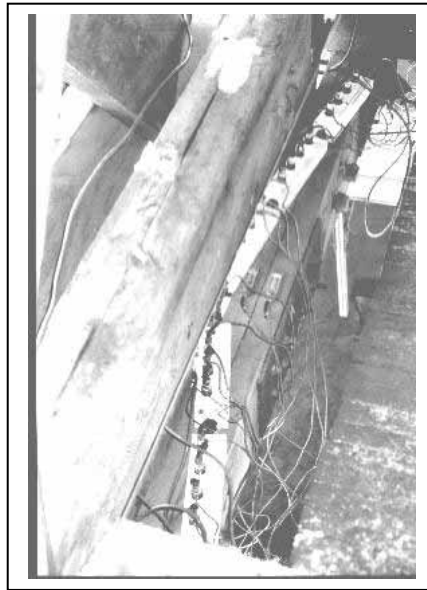

Figure 175. Depicts the “rat’s nest” of wiring accompanying the installation of the 46 transducers. The equipment is shown mounted on top of the lower bottom chord element. The upper bottom chord element is in the foreground. The edge of the nail-laminated deck is shown along the right edge (a curb timber had been removed).

The mounting of these transducers to the chord elements required a work platform to gain access to the area and removal of the siding adjacent to the desired installation sites; see figure 176. Since we were getting ready to rehabilitate the bridge anyway, we were able to easily provide the platform and remove the siding. The actual installation of transducers was accomplished by wood screws and washers and was completed in a few hours. The recording of the data from passage of a known weight vehicle was accomplished in an hour including three passages to obtain comparison values. Hence, the contractor’s technical representative was on site less than a day. Their office evaluation and manipulation of the data required a few days and a concise report was provided that included minimum and maximum strain information in graphical and tabular form for the various locations with a discussion of relevant observations.

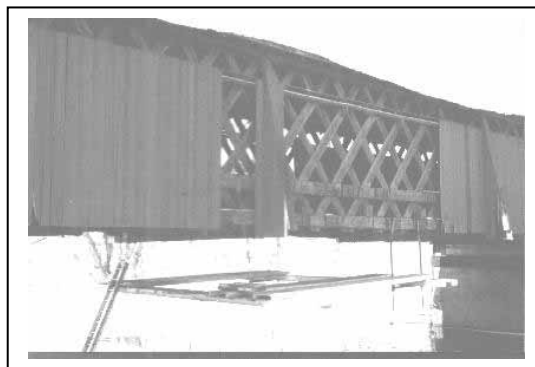

Figure 176. The temporary platform suspended beneath the bottom chords to enable access for strain gage installation. The siding was removed to facilitate the testing, but the bridge was scheduled to undergo a complete rehabilitation after the testing, which required siding removal for other purposes.

With the data in a spreadsheet, I was able to manipulate it to examine a number of different aspects, including axial indications as well as bending indications. I found this activity to require relatively little time

compared with the labor-intensive examination of the Finite Element analysis results, yet it obviously is limited to discrete locations on the bridge.

Surprisingly, the results, when converted to force, indicate substantially smaller values than were anticipated by a Plate Girder Analogy analysis. This is a simplified means of examining forces in a truss by simulating its behavior as a plate girder with equivalent stiffness. At this time, we continue to evaluate the data for potential explanations and ramifications.

We are now considering various potential followup tests at our other two historic covered bridges. While this work has not concluded the search for full understanding of the behavior of the Town lattice timber truss, we are another step closer. Additional laboratory testing is being planned, as well as expanded field testing and related computer simulations.

Appendix B. The Trials and Successes of Covered Bridge Engineering and Construction—Hamden Covered Bridge, Delaware County, NY

Abstract

The rehabilitation of an historic covered bridge is confronted with numerous challenges. The engineering involves issues unfamiliar to many of today's practicing engineers. The relatively few, and geographically dispersed, covered bridge construction projects in modern times often involve contractors with limited experience with the nuances of covered bridges. Three bridges in Delaware County, New York have recently undergone extensive rehabilitation. This paper discusses several of the challenges associated with one of the bridges. Although not funded by the National Historic Covered Bridge Preservation Act (the third bridge was), the work was performed to the same standards as required by that program.

Hamden Bridge—130-foot (39.6 m) span Colonel Steven Long truss configuration:

- How and How *Not, to*, Move a Covered Bridge.
- Bottom chord splices—the original Bolt-of-Lightning splices, while awe-inspiring for their technical complexity of fit, were substantially weaker than the unspliced material. The details of the bottom chord/post connections were such that substantial improvement of the capacity of the splice was impossible. Hence a one-piece 130-foot- (39.6m) long glue-laminated bottom chord was used.
- Inadequate initial bracing of the structure as evidenced by the previous need for a mid-span supporting bent.
- High stresses in several web members indicating the need for remedial action to reduce loading—accomplished by using metal roofing rather than wood shingles.
- The myth and reality of Colonel Long's wedges.
- The need to oversize connector holes in joints.
- Just how tight are the counters to be?
- Tricks to keeping the overhead lateral bracing tight.

Introduction

Description of the Bridge

The Hamden Covered Bridge, built in 1859, spans the West Branch Delaware River near the hamlet of Hamden in Delaware County, New York. The County owns three covered bridges and began a major rehabilitation of all three bridges in the past several years. This bridge was the second of the three to be rehabilitated.

The bridge is supported by truss configurations patented by, and named for, Colonel Stephen H. Long in 1830. The all-timber truss is similar in nature to a multiple kingpost but has counters in each panel. The popularity of the truss was quickly overshadowed by the use of metal vertical members in a truss configuration patented by William Howe in 1840. Hence, there are only about 25 remaining covered bridges supported by Long trusses.

Pre-rehabilitation Conditions

During its existence, the Hamden Covered Bridge has been rehabilitated several times, the last time in the 1970s. By the mid 1990s, the bridge was racked and many of the verticals near the end of the bridge exhibited crushing and bending distortions, indicating significant overstress. Figure 177 depicts a pre-construction view of the bridge.



Figure 177. View of the Hamden Covered Bridge prior to work in 2000. Note the mid-span timber bent added in the 1970s to help support the sagging trusses. Also note the external top chord braces.

Engineering and Construction Challenges

How, and How-Not, to Move a Covered Bridge

The West Branch of the Delaware River can rise rapidly during times of heavy rain. It is also a highly regulated waterway and trout stream. Therefore working over the water would represent special challenges. Accordingly, the contractor chose to relocate the span to its southern approach roadway section for the reconstruction process. The construction documents did not object to such a move. The documents required engineering sketches and calculations addressing the proposed means for support of the bridge during its reconstruction. Hence, engineering information was required for the relocation.

The contractor had previously completed the successful reconstruction of another covered bridge owned by Delaware County (the Downsville Bridge—a 170-foot- (51.8 m) long bridge built by Robert Murray, who also built the Hamden Bridge), also using a Long Truss configuration, but supplemented with a stiffening arch. That project had gone well, and the contractor had demonstrated great skill and care with that work. His company has an excellent reputation for construction work, including historic repairs of timber structures.

The contractor proposed to relocate the bridge using a pair of heavy cranes, one on each shore, but had not presented engineering support for the work. We decided to allow the move to proceed, albeit with some trepidation. Unfortunately, the move culminated in an accident that effectively broke the bridge into two pieces and dropped them into the river (see figure 176).



Figure 178. How NOT to relocate a covered bridge for repair work.

Fortunately, no one was hurt during this accident and, ultimately, the damage to the bridge did not involve many components beyond those already identified for replacement for other reasons. We, the County, shared in the blame in that we did not insist on the engineering support prior to the work.

The reconstruction of the bridge proceeded through the summer and fall. When ready to relocate the bridge back to its reconstructed foundations, the County insisted on the use of a roller system supported on false work. The County provided and installed the majority of the false work system while the contractor provided a specialty subcontractor to oversee the relocation. That work went without a hitch (see figure 179). This system proved to be a good way to relocate a covered bridge.

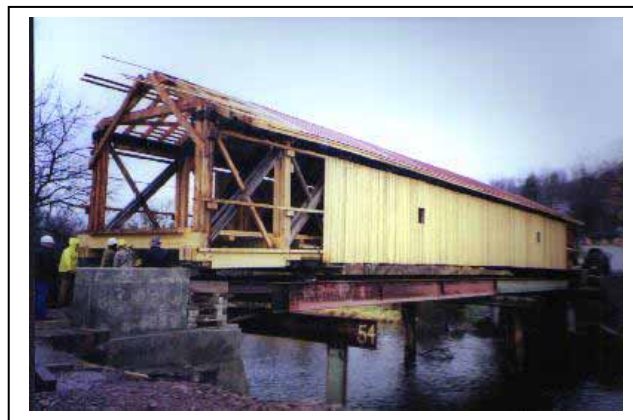

Figure 179. Successful relocation of the bridge using rollers on a false work system. The siding and roofing at the ends awaits final bearing installation.

Bottom Chord Splices

This style of truss contains three separate bottom chord sticks with a pair of vertical posts between them. The members are shouldered at the connections to facilitate load transfer (a “shoulder” is a notch cut into a face of a member that joins another at right angles). The chord members contained a larger central stick of 9 inches by 13 inches (229 mm by 330 mm), flanked by smaller sticks of 5 by 13 (127 by 330). The trusses were originally built of local Eastern Hemlock with stick lengths of up to 50 feet (15.2 m) (much larger than is readily available today!). The traditional form of splice for such an arrangement at the time of its construction uses a splice termed a “Bolt-of-Lightning” detail (see figure 180).



Figure 180. A classic “Bolt-of-Lightning” splice. It relies on end bearing and shear to transfer the forces. The cuts include vertical mitering to allow the bearing blocks to settle into a tight fit, without falling out, should the joint tend to stretch

Unfortunately, the proportions of this truss and its joinery are such that the splice is substantially weaker than the main members. Any potential alteration of the sizes of the bottom chord members would require related changes in other truss members and was considered an inappropriate alternative. Based on work undertaken earlier at the Downsville Covered Bridge, it was decided to replace the bottom chords with three one-piece glue-laminated members (that’s right—130-feet (39.6 m) long in the Hamden Bridge; 170-feet (51.8 m) long in the Downsville Bridge!). The fabrication and delivery of such beams was impressive in its own right. Yet, these one-piece chords eliminated the need for splicing and the problems associated with it.



Figure 181. One-hundred-thirty-foot- (39.6 meter) long one-piece bottom chords—monsters to fabricate and deliver and a handful to work with.

Comparing Bracing—Previous versus New

The Hamden Covered Bridge has had external top chord bracing supports, similar to some other bridges in the area. Some refer to such bracing as buttresses; some of us have a more derogatory term—elephant ears—since in my opinion, they are evidence of an unwillingness to make the internal bracing system do its job. It is unclear if these external braces were original at the time of construction, or added later when the bridge exhibited distress (refer back to figure 177 and note the external braces).

The original roofline is relatively shallow on the Hamden Bridge and offers little room to improve the internal bracing system. Again, in large part following the work performed at the Downsville Bridge, the roof of the Hamden Bridge was removed to allow the replacement with a more conventional sloped roof with more space to install a substantial internal bracing system. The tie beams were joined with oversized rafters and knee braces of sufficient size and connection strength to maintain the stability of the bridge.



Figure 182. Internal bracing. It is certainly hard to pick out, but the major light-colored diagonal member is the Knee Brace. It is bolted to a lighter color Tie Beam and behind it with a Principal Rafter. The darker members are the original upper lateral system.

High-End Web Member Stresses

Prior to this rehabilitation of the bridge, several of the members at the ends of the trusses exhibited significant distortion and overstress (refer to figure 183).



Figure 183. Diagonal to post connections at the top chord indicating significant overstress.

If you look carefully you see that the top of the vertical post is cracked above the upper right bolt. Also note the general bend of the vertical to the right. The Knee Brace is in the foreground connecting to the Tie Beam just out of the top of the photograph. The pair of main Diagonals is on the right and the Counter is on the left. The reconstruction of the bridge replaced these split posts with heavier members.

The Myth and Reality of Colonel Long's Wedges

One of the interesting aspects of the patent application of Colonel Long was the provision of wedges at the connection between vertical post and chord. Quite a bit has been written about these wedges. They have been attributed as the precursors of post-tensioning systems that have become commonplace in the second half of the 20th Century. An oft-used diagram to demonstrate their function is with a two-panel truss. It is fascinating to delve into this issue a little more and find that while the two-panel truss can be manipulated to demonstrate a post-tensioning effect from the wedges, a truss with more panels cannot support this concept.

Instead of pursuing this aspect further, this writer prefers to consider the other advantages of the wedges. The interface of the vertical members and chords is one with very high side-grain compression in the vertical against end-grain compression in the chord. These forces are the direct consequence of the horizontal component of load in the diagonal members as they are transferred to the chords in axial load. A thorough review of the stresses of the joints of the Hamden Bridge indicates that the wedges play an important role in distributing the stress to the post over a greater area to effectively reduce the side-grain compression. In this writer's opinion, it is conceivable that Colonel Long recognized the advantage of the wedges in this way.

However, there is another twist to this issue. Some Long trusses were built with wedges in both top and bottom chords, while others (like Hamden) were built with wedges only in the bottom chord. The side-grain bearing issue is just as important in the top as bottom; hence, the posit that Long recognized this strength is counteracted by leaving them out of the top chords. The wedges are easily visible in the top chord connections, while the bottom chord wedges are hidden beneath the floor beams and a careful inspection from below is necessary to observe them.



Figure 184. Wedges used in the connection between vertical post and chord—you have to look closely on the left side of the right post. In the writer's opinion, their value is principally to distribute the high side-grain bearing stresses in the post to a larger area.

It would be interesting to inspect all remaining Long truss bridges (there are only about 25 extant covered bridges that are supported by some variation of a Long truss) to compare the use of wedges against their date of construction to see if the use evolved. Of course, it must be recognized that the actual builders of the bridges could have individual impressions of the merits of the wedges, contrary to what may have been intended by Colonel Long. Hence, such an exercise, while interesting, may not lead to a clear answer to this issue.

In any event, we decided that the merits of the wedges for the reduction in post stresses were substantial and we introduced wedges in the top chord of the Hamden Bridge during its reconstruction. No attempt was made to use the wedges to affect the shape of the truss.

Connectors in Joints of the Long Truss

The joints of a Long truss between vertical post and chord member usually contain a single or occasionally two transverse bolts (refer back to figure 183). Recall from the earlier discussion that the transfer of force from one member to another involves a double shoulder detail. That is, the horizontal shoulders of the post mated against the horizontal edge of the chord transfers vertical load through the joint. (This is the primary means of keeping the floor from falling from the bridge—the floor beam sits atop the chord, which is held from sliding down the post by the shoulder in the post.) Similarly, the vertical shoulder in the chord mated against the vertical edge of the post transfers the horizontal component of load from the diagonal through the post to the chord.

When one considers the strength of the bearing surfaces of the shoulders with the potential shear strength of the bolt, one finds that the bolt does not contribute much to the strength of the joint. However, the bolt represents a *potential failure mechanism* of the joint, as described hereafter.

In many instances, timber is placed in a truss after some initial drying. Yet, during the life of the truss, the members will continue to change sizes due to moisture retention in times of very high humidity (or in the event of a leaking roof directly above such a joint) or additional drying. When the joint must transmit high stresses (typically at the few end panels of a truss), the post tends to deform and bend under the high stresses. If the bolt has been installed in a typical hole (one only slightly larger than the bolt), side-grain bearing (and its concurrent tension perpendicular to grain) can develop at the bolt. Since timber is relatively weak in such side-grain tension, a split often develops from the bolt through to the end of the member.

Accordingly, the reconstruction of the Hamden Bridge involved an extra step to ream the holes of the transverse connectors after the initial reconstruction of the trusses and before the bridge was released from its false work. Such reaming will allow some future change in sizes of the post from swelling and/or shrinkage and distortion from loading without the imposition of significant side grain tension. The same considerations are involved in many types of timber joinery typical of covered bridge construction.

How Tight Should the Counters Be?

The counters of a Long Truss (those members of the “X” in each truss panel that are opposite of the main diagonals) are used to provide resistance for the passage of heavy vehicles (or unusual snow loading); the discussion hereafter is limited to vehicles for clarity). Especially for the panels nearer the center of the bridge, the dead load in the main diagonals can be less than the load imposed by the passage of a heavy vehicle. The net result for some positions of vehicular loading is that the force in the main diagonal due to the weight of the bridge can be counteracted by that caused by the vehicle’s weight, that is, the main diagonal can actually become “loose”, since it is not connected for tension. Hence, the counters assist the main diagonals by offering compression resistance to prevent the distortion and potential failure of the truss panel.

Yet, the potential load in the counters is dependent on their initial installation. The counters are not required to support dead loads, so when no vehicles are on the bridge, the counter could technically be “loose”. However, if they were loose under the no-load condition, then they could fall out, or work loose, after repeated structure loading by vehicles.

So the practical question when dealing with counters in these types of trusses is, how tight at initial conditions? This writer is unaware of any documented guidelines and relies on general structural engineering instincts. The load in the counter is typically controlled by manipulation of opposing (“folding”) wedges installed at either the top or the bottom of the counter. The harder one pounds the wedges into place, the more load is forced into the counter. After tightening the wedges until the counter feels “snug,” it is then important to prevent the wedges from loosening. We used heavy wood screws in the wedges to hold their position and to facilitate future retightening after the bridge had served for awhile and had attained a typical moisture content. Many extant historic covered bridges contain similar wedge details without screws and often seem to stay tight strictly due to friction in the wedges. However, reports of counters (and even main diagonals of some trusses) falling out of bridges are also common.



Figure 185. Typical “folding wedges” of a counter. In this application, the main (glue-laminated) transverse member in the middle of the photo is the Floor Beam. The counter on the left bears against the wedges, then the Floor Beam against the side of the post.

So what is the definition of “snug”? In the context intended herein, a snug counter is one that cannot be moved sideways much when firmly shaken by hand. This test is appropriate prior to the installation of any

screws or other fasteners in the wedges. If such a shaking dislodges the wedges, then the counter is probably not tight enough.

Upper Lateral System Diagonals—How to Maintain Tight Fit?

The diagonal members of the upper lateral system are typically connected to the Tie Beams with mortise and tenons (a mortise pocket is cut into the side of the Tie Beam; the end of the diagonal is cut to a mating tenon). Folding wedges are used here also, behind the end of the tenons, within the mortise, as a means to maintain the diagonals with a tight fit. It is quite easy to move the top of the trusses laterally by driving the wedges more. When the chords are straight and the laterals are tight, then the wedges should be locked; again we use heavy screws.

Yet, there is another trick that may not be so obvious to the casual observer. Many of the original builders of covered bridges positioned the mortise pockets in the Tie Beam to be vertically offset from what they would be for straight lateral members. In this way, the opposing diagonal members in each panel had to be forced vertically to fit into the mortise (assembly of such a system is not easy to make in the field!). Hence, even if the end folding wedges work loose, the bowed diagonals tend to hold each other in position against simply falling out. Routine inspections of the structure will likely discover loose wedges prior to a potentially life-threatening accident such as a lateral falling into the path of an oncoming vehicle.

Completed Bridge

The timber work was completed by the contractor in late 2000 after the asphalt plants closed for the season. The County completed the approach grading and asphalt work, installation of guide rail system, and slope protection system in June, 2001 and the bridge was reopened to traffic on July 2, 2001. The contract was for \$558,000 and the County incurred approximately another \$150,000 for the work cited above along with the costs of engineering and inspection support.



Figure 186. Near final exterior view. Guide rail not yet installed and final seeding and mulch also not yet in place.



Figure 187. Final inside view. Note the lighter-colored replacement members.

Acknowledgment

David Fischetti, P.E., Cary, NC, performed the initial engineering on this project.

Appendix C. Rehabilitation of Fitch's Covered Bridge

History of the Bridge and Condition Prior to Current Project

The Fitch's Covered Bridge was originally built in 1870 on Kingston Street over the West Branch Delaware River in the Village of Delhi to replace a previous covered bridge destroyed by floods. The bridge was built by James Frazier and James or Jasper (conflicting information) Warren. The bridge proper was built for about \$1,900 and the stone abutments were erected by M. Hathaway and W. A. Cummings at a cost of \$725. When the Town decided to replace the covered bridge with a modern iron bridge in 1885 by the popular Groton Bridge Company, the decision was made to relocate the 15-year old covered bridge to a site upstream in East Delhi, named for a previous crossing of Fitch's Bridge. The relocation of the span is credited to David Wright and a town crew. Figure 188 depicts the bridge early in this project. The hole in the roof and siding removal allowed the steel piles to be driven through the roof for support of a steel falsework system.

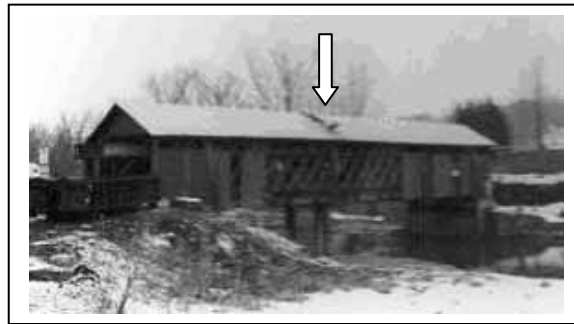

Figure 188. Start of work.

The bridge is supported by Town lattice trusses, so named for Ithiel Town who received his first patent for this truss configuration in 1820. Unlike the majority of Town lattice trusses, the Fitch's Bridge contained splayed lattice members at the end of the trusses (at the time of our new rehabilitation). The splayed lattice members are the result of an alteration of the bridge that was originally built without the splay, typical of the traditional Town lattice. The splay arrangement may have resulted from trying to fit the bridge from Delhi into existing abutments at Fitch's Crossing that supported a shorter span (the existing lattice members, prior to our work, still contained the original hole pattern compatible with traditional parallel lattice. Comparison of the open original holes demonstrates how the members were rotated about one of the holes in the top chord). A recently obtained photograph depicts the bridge prior to its rehabilitation in 1976 and the splayed lattice members are evident then. Further, their condition had deteriorated significantly and they were supplemented with large steel plates, apparently installed in 1976. In any event, the splayed lattice members are not unique to the Fitch's Bridge, and are found on other extent covered bridges, especially in this geographic area. Also note that the bridge contains only a single level of top chords, which is also somewhat unusual, but found in many geographic areas. Figure 189 depicts a view of splayed lattice members prior to this project. Note the empty holes of the original construction, prior to the splay of the members. And note the extreme deterioration of the ends of the lattice, a condition that was hidden behind steel plates.

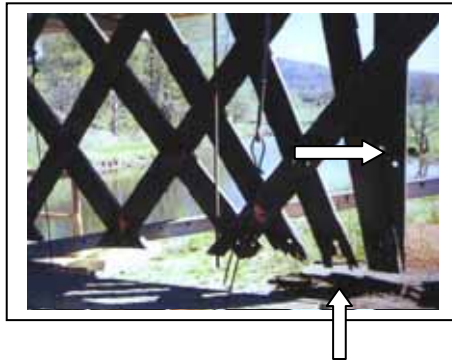

Figure 189. Deterioration at end.

The original interior knee braces were too weak to maintain the dimensional stability of the bridge. At some time external bracing was added; some identify these features as buttresses or “elephant ears”. These forms of external bracing exist on other bridges; they were not original on *typical* historic covered bridges, but were found on some covered bridges. It is not known if they were original to this bridge.

The original floor was hung beneath the lowermost chord via iron rods. This is supported by a recently obtained photograph of unknown date (figure 190). The photo also shows a ramp floor at the north end of the span but inside of the bridge. The ramp transitions to a floor that would appear to be at the correct elevation to have been supported beneath the lower bottom chords. In 1976, the floor was modified to install it onto the lower bottom chord in accordance with the more conventional approach for this type of bridge.



Figure 190. Older “hung” floor.

The 1976 replacement floor utilized floor beams comprised of three 3 by 12 (75 by 300 mm) members spiked together that supported longitudinal stringers on top of the floor beams and transverse timber nail-laminated decking. The majority of the floor beams were placed on an 8 foot- (2.4 m) spacing, although there was a panel near mid-span with a 12 foot (3.6 m) spacing. The stringers were positioned at about 2 foot (610 mm) spacing. The floor system was deteriorated and too weak for retention. Figure 191 depicts the partially removed 1976 floor system. The near edge of the floor is the transverse nail-laminated decking. The longitudinal stringers are obviously not uniformly spaced. Don’t be deceived by the transverse diaphragms between stringers; the floor beams are beneath as visible on out in the span.



Figure 191. Partially removed 1976 floor.

The bridge was covered with metal roofing, last replaced in 1976, and was in bad condition.

The dry-laid stone abutment is still exposed on the South Abutment, although a concrete cap exists atop the stone, while concrete has been installed in front of the stone of the main portion of the North Abutment (refer to figure 190). Steel sheet piling has been installed in front of the downstream wing wall. This work is believed to have been performed in 1976. The North Abutment with a concrete facade in front of the dry-laid stone and steel sheet piling along the wings is depicted in figure 191. The rusty steel frame at the corner of the backwall and transverse across the top of the stem was left over from the 1976 work; it was used for erection and not for support of the bridge and was removed in this project.



Figure 192. South Abutment prior to work.



Figure 193. North Abutment prior to work.

Modifications/Rehabilitation as Part of Current Project

The lattice splay feature was not retained, since it was not original to the bridge and it leads to stress concentrations that are nearly impossible to accurately analyze. Further, the members were so badly deteriorated as to be unusable. Since the abutments were judged to be sound in their current condition, it was decided to remove a portion of each corner to allow installation of a longer truss (see figure 194). The longer structure resembles the original structure when built for the Delhi site (to the extent we can deduce that appearance.)



Figure 194. Longer trusses and new recess in existing abutment.

The chord elements of the bridge were deteriorated at many locations, especially along the bottom chord at the intersection of the lattice elements, and along the top chord. The entire upper and lower bottom chord elements were replaced due to deterioration. A number of the existing top chord elements were replaced due to deterioration, along with all new elements at the ends to make a longer truss. Similarly, several of the lattice elements were replaced due to deterioration. In all cases, the chord and lattice elements were replaced with similar-sized sawn Southern Pine or Douglas Fir members. Traditional wooden pegs (trunnels) were used to connect the truss elements and those existing pegs in good condition were reused.

The Elephant Ears were removed and a stronger internal bracing system was installed. Most of the original upper lateral members were retained. The tie beams and knee braces were replaced with

stronger components. Traditional wooden peg connectors and matching timber wedges similar to those in the original construction were used.

Another feature related to the internal bracing system was the use of larger rafters (3 inches by 12 inches) (75 by 300 mm) adjacent to the tie beams and knee braces; these members are identified as “Principal Rafters.” The common rafters were replaced using 2 inches by 8 inches (50 by 200 mm) sawn members. Figure 195 depicts the reworked internal bracing system. Note the retained darker upper lateral members.



Figure 195. Reworked internal bracing system.

The floor was completely replaced, using the common configuration of floor beams and longitudinal decking, typical of most Town lattice Bridges. Floor beams are often spaced at 2 feet (600 mm) on centers in many Town lattice bridges, yet analysis work determined that the floor beams in this bridge could be spaced at 4 feet (1.2 m.) The floor beams are comprised of glue-laminated components, to gain sufficient reserve capacity to be able to handle overweight vehicles. The longitudinal decking is conventional 4 inches by 12 inches (100 by 300 mm) Douglas Fir timber plank. We also installed sacrificial 2 inches- (50 mm-) thick oak running planks on top of the primary deck planks. An image of the installation of the longitudinal planks is depicted in figure 194.



Figure 196. Partially installed deck.

New horizontal metal rods were installed to hold the floor system and bottom of the trusses together. Such rod systems have become quite common installations over the past many years for those locations where adequate underclearance is not possible and flood waters and debris can pull the downstream truss out from under the floor beams. Similarly, metal rod hold-down anchors were installed at each corner to prevent the truss from floating upward during extreme events.

Based on community preference, the metal roofing material was replaced with traditional Western Cedar wood shakes (see figure 197) supported by rough cut 2 inches by 4 inches (50 by 100 mm) nailers.



Figure 197. Installing cedar shakes.

The bridge was previously covered with vertical rough-cut siding without battens. The siding was replaced with rough cut 1 inch by 12 inches (25 by 300 mm) vertical Hemlock, but battens were used to lessen weather damage to the truss components (see figure 198).



Figure 198. Siding details during installation.

Modifications of the abutments was limited to removal of a portion of each corner to accommodate the new longer trusses, (about 8 feet (2.4 m) longer to eliminate the splayed lattice arrangement.) The floor system maintains the same distance between abutment backwalls.

The entrance to the bridge on the North approach involves non-standard geometry, yet it has been acceptable to the local users of this bridge for a very long time. Accordingly, the non-standard geometry has been maintained. As a consequence, and due to the lack of accident history at the entrances to the bridge, an approach railing system comprised of heavy timbers was installed. Its appearance meshes well with the timber covered bridge. The poor alignment at the North approach tends to make vehicle speeds extremely low. For these several reasons, these vehicle guidance systems are judged to be prudent and acceptable (refer to figure 199.)



Figure 199. Approach railing configuration at north entrance.

Original and New Construction Techniques

To the extent possible and practical, the new bridge maintains traditional construction materials and techniques, including:

- All sawn truss and bracing elements.
- Wooden peg connectors of the Town lattice trusses and primary bracing.

- Retention of the dry-laid stone abutments.
- Use of matching wedges in the upper lateral system connections.
- Use of cedar shake roofing material.

The superstructure of the bridge was restored to its original full-length and parallel lattice element configuration. The external bracing, added during the life of the bridge, was removed, requiring more reliance on the internal system, similar to the original construction.

A feature of the bridge that was altered relates to the use of glue-laminated floor beams. Today's design specifications and minimum loading requirements routinely demand heavier and/or stronger floor beams than were typical at the time of original construction. Few preservationists object to such modifications due to the fact that floor systems have routinely been replaced at least once during the life of the bridge, sometimes several times.

Problems and Solutions

A number of issues were encountered which demanded unanticipated solutions, including:

Hidden Deterioration

Many of the elements of Town lattice trusses are positioned beside mating elements (e.g., chord elements along the top chord or chord/lattice elements at their intersections). Over the life of the structure (in this case more than 130 years), deterioration from roof leaks led to significant section loss of elements. There is no currently available practical means of identifying all such deterioration in advance of disassembly of the truss during its reconstruction. Accordingly, almost all Town lattice trusses are found to have more deterioration during reconstruction than anticipated during the engineering phase of the project.

Similarly, powder post beetles had infested many of the hardwood pegs and surrounding primary element material. The extent of the damage by insects was more extreme in some instances than anticipated. In one unusual case, the initial damage by insects led to an entrance into the chord area by a rodent that hollowed out the pair of mating chord members, leading to only a shell of the members remaining. No outward appearance of distress was evident and no inspections had ever identified same.

Replacement of Top Chord Elements

Isolated top chord elements were sufficiently deteriorated to warrant replacement, primarily from rot due to long-term leaks in the roof. However, the trusses had attained a permanent distortion such that in many cases the transverse wooden peg connectors were no longer straight or horizontal. Accordingly, if one wished to replace an inside element, but not the corresponding exterior element, then the procedure needed to use existing holes as a template for drilling the new holes in the new material. In some cases, the process led to misplaced holes in the new material such that the new material would not be properly positioned vertically. In this case, reuse of the existing holes would not have satisfied the requirements and some existing elements had to be replaced also, in order to have acceptable peg locations in the new material.

Vertical Camber of the Trusses

While it is desirable to have a smooth curvature of the trusses when finished, in this case, we were locked into the position of the existing trusses. Otherwise, we would not have been able to reconnect intersections of lattice and chords using existing holes. Accordingly, the camber cannot be adjusted to any significant degree during the rehabilitation of a Town lattice truss without replacement of more material, and/or replacement of existing trunnels with oversized pegs in reamed holes.

In our case, the downstream truss had more camber, and more uniform curvature, than the upstream truss. Fortunately, both trusses retained positive curvature of sufficient amount as to be acceptable

without having to do more extensive replacement. However, the roof lines were able to be made smooth by adjusting the birds mouth of the rafters.

Research Conducted

Two types of physical research were conducted as a part of this project.

Field instrumentation of portions of the existing Town lattice trusses was performed to assess the distribution of forces around chord interruptions and trunnel (wooden peg) connections of chords and lattice elements. To our knowledge, this work was the first of its type for this kind of application. The work was performed by a contractor. The testing included installation of 46 strain transducers at various locations on the bridge and recording information from the passage of a 10-ton (9 MT) vehicle. An evaluation of the information indicated that actual strains were less than predicted, and generally supported implications from finite element modeling of similar lattice trusses.

A spare transducer was applied at the bottom of a transverse floor beam during the field instrumentation. The results of that particular measurement were especially interesting and substantially less than expected. As a follow-up, that floor beam (scheduled for replacement due to inadequate strength) was tested to failure. The beam failed at a load much higher than expected. While this particular test could not be used in any conclusive way, due to the lack of multiple samples or repetitions, the information gleaned from the work was nonetheless interesting.

Costs

The rehabilitation of the Fitch's Covered Bridge was undertaken without comparison to the costs of replacement, due to its status as an historic bridge and eligible for inclusion on the National Register of Historic Places (a status it has since received). The project included an extensive rehabilitation of the timber bridge and modification of the abutment caps. All design and construction work was performed by County forces. The cost of the work was about \$425,000.

Final Project Photos



Figure 200. Elevation view of completed bridge.



Figure 201. View of south entrance and railing configuration.



Figure 202. Internal view of completed bridge.

Appendix D. Rehabilitation and Resiting of the Brown's River Covered Bridge, Westford, VT

Bridge Description and Project Background

The existing Brown's River Covered Bridge, built in 1837, served until 1965 when it was bypassed and abandoned. Some repairs were performed in 1975. In 1987, again in bad shape, the bridge was removed from its foundations and set on cribbing in a nearby field. Work on covered bridges was not as popular at that time, and the removal was performed with power provided by oxen and capstan. The effort to remove the bridge from its foundations was filmed as part of a Public Broadcasting Service (PBS) documentary featuring Milton Gratōn (the late renowned covered bridge reconstruction specialist). Gratōn began repair work, but funds were exhausted before the work was completed.

The bridge sat idle in the field overlooking its foundations, awaiting additional funding to finish the project. A long effort chasing grants culminated in funding via the Intermodal Surface Transportation Efficiency Act of 1991 and supplemental funding in 1999 from the Transportation Equity Act for the 21st Century.

With sufficient funds now available, a contract was let for final repair of the bridge and its abutments and resiting the structure to its river crossing. Bridge repair work began in early 2001, and the bridge was relocated on July 20, 2001 on heavy moving steerable dollies, towed by large wrecker trucks. Back at its original site and adjacent to a modern bridge that supports vehicular traffic, the covered bridge serves only pedestrian traffic.

Engineering and Construction Challenges

A number of issues caused this project to be especially challenging. From an engineering perspective, the lack of sufficient funds resulted in more reliance on the contractor to handle issues as they came up without thorough plans in advance. Multiple telephone conversations ensued during the work along with a few site visits. Several of the issues are discussed below.

Bridge Condition at the Start of the Project

Unfortunately, the repairs that began in 1987 were not completed, and the bridge sat on cribbing for 13 years. During that time, the cribbing suffered some differential settlement that racked the bridge. Although it is not certain that this was present in the 1980s, two-thirds of the top chord of the south truss had been attacked by powder post beetles when the project began. The wood shingle roof installed in the 1980s was now leaking. The ends of the bottom chords had been replaced, and large bolster beams were positioned beneath the chords. There was no direct splice of the chords, and the connection of the bolsters was judged to be inadequate to restore the integrity of the bottom chords without additional work. Several damaged, broken, or missing components of the bracing were not yet addressed.



Figure 203. As the bridge sat for 13 years.

The abutments remained as they were when the bridge was removed. The upstream corner of the east abutment was separated from the stem, and a section of stone wall along the wing wall was near collapse condition. The caps and backwalls awaited replacement to accommodate the rebuilt superstructure.

Limited Engineering

At the time of the final push, funds were extremely limited, yet the 13-year effort to obtain funds had been extraordinary. Recognizing that the bridge would not have to support vehicular traffic and that pedestrian loading would be limited at this rural location, the engineering was to include:

- Evaluation of the current condition of the bridge.
- Identification of necessary repairs based on judgment and experience with covered bridge work.
- Limited analysis of critical elements, as judged mandatory (primarily limited to the connection of the bolster beams to the bottom chord).
- Preparation of limited drawing details.
- Preparation of technical specifications with reliance on lump-sum bid items for the several major tasks, including timber structure repairs, foundation repairs, timber structure relocation, and timber flooring.
- Site attendance at the time of the relocation of the bridge to evaluate the proposed work plan and equipment.

The Historical Society retained another local engineering firm to prepare a complete contract bid document including bid forms, agreement, bond requirements, and other standard information.

While this situation is not desirable, and should not be undertaken by inexperienced personnel, this project approach proved to be successful in this instance, in large part due to the close working professional relationship among the contractor, engineer, and owner's representative.

Timber Repairs

One of the important issues related to this work was the need to replace truss components while attempting minimal removals. The top chord of the east truss was originally built in three pieces with a special joinery connection (refer to figure 204). The chords were positioned down onto tenons from the ends of the posts. Replacing the chord, therefore, required the temporary support of the rafters and tie beams to raise them out of the way.



Figure 204. Replacement top chords.

While replacing the top chord, a section of substantial rot was found in the top of one post (refer to figure 205). No external evidence of such deterioration was visible. Yet, the post either had to be partially or completely replaced. The decision was made to completely replace the post. A couple of other posts were also replaced to better address previous partial repairs that were judged to be insufficiently connected.



Figure 205. Hidden rot inside top of old post.

Straightening the structure as a consequence of these rather extensive repairs and long-term cribbing differential settlement led to discovery that the existing knee braces would have to be replaced to fit the restored geometry.

One of the features often added by Mr. Gratōn in his restoration of scores of covered bridges was bolster beams beneath the ends of the bottom chords. These elements project beyond the front edge of the abutment seat and serve to stiffen the ends of the truss. However, the bolsters added to this bridge were especially large and long—three panels long, in fact (refer to figure 206). Bolsters are usually added separately from the chord, so that they do not act as truss members; instead they supplement the behavior of the truss by adding bending capacity in addition to the truss behavior. The existing bottom chords had been severed at sound material away from the rotted end portions, in the second or third panel from the end. Instead of installing a tensile splice to connect the new ends to the original portions, the large bolsters were connected to the chords by a few vertical bolts. It may well be that these connections were not completed at the time work was abandoned. Figure 206 also shows the arches that were terminated at the bottom chord without extensions to the abutment.



(Photo courtesy of Joseph Nelson)

Figure 206. Bridge moved, but not down off temporary cribs.

Project managers inherited a situation in which the existing bolsters were expected to serve as replacement bottom chord elements being subject to axial loads, in addition to their normal bending behavior. While the bolsters were no doubt large enough to accommodate such expectations (114 by 406 mm (4.5 by 16 inches)), they had not been connected in a way to adequately transfer the loads across the butt connections of the bottom chord.

Accordingly, we devised a plan to install a series of timber shear blocks at the interface of the bottom of the chord to the top of the bolster. In combination with the bolts, the additional shear blocks would provide an acceptable capacity. The plans called for rectangular 100-mm- (4-inch) high by 200-mm- (8-inch) wide hardwood blocks to be inserted into new pockets cut into the interface from the side. The contractor had considerable experience using round wooden dowels to accomplish the same effect and believed the round dowels would serve better in this instance. Following extensive conversations and additional analytical evaluations, it was decided to allow the use of the round dowels (refer to figure 207).

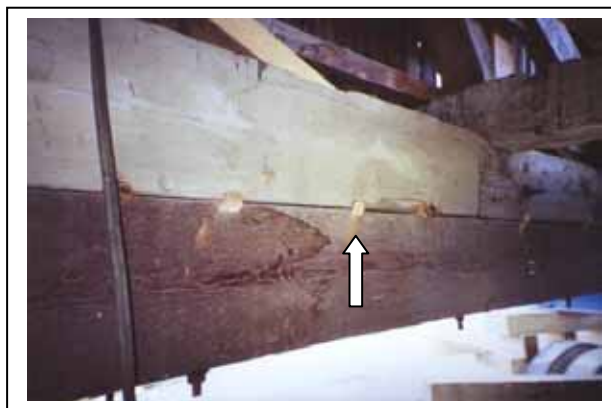

Figure 207. View of shear dowel reinforcement.

Modified Burr Arch Details

Figure 204 clearly shows that the arch elements have been cut off at the bottom of the bolster beams. In a classic Burr arch, the arch elements project down past the bottom of the chords to bear against the abutment. In so doing, they can true arch behavior to augment the truss behavior of the timber structure. However, in those bridges that have had an alteration to terminate the arch without bearing on the abutment, or if the bridge had been built originally like that, the arch cannot offer much assistance to the truss. Such structures are often referred to as modified Burr arches.

Further, the connection between arch and truss is often a single bolt element at the intersection of the center of the vertical elements of the truss and the centerline of the arch. It is common to observe that these bolt elements are deformed from the excessive forces attempting to connect the two types of systems together. This is another reason that makes the analysis of such combination structures especially challenging.

The arch components on this bridge are comprised of a pair of solid-sawn members that straddle the truss. As the arch in the center of the bridge comes lower toward the bottom chord as it traverses toward the end of the bridge, it has been deflected outward in this bridge to pass the bottom chord. Hence, the gradual appearance of the arch in figure 204. Some bridges are built such that the arch components are interrupted at the bottom chord with a splice so that the arch remains in the same plane as the bottom chord.

Foundation Considerations

The original stone abutments had been faced with concrete, as is common. While the quality of concrete facing is not great, the bulk of it seemed sound and stable. There was no evidence of deep-seated foundation failures; therefore it was quickly decided to retain the bulk of the abutments. New caps were required due to a change in the floor configuration (the trusses originally extended beyond the floor; therefore, the concrete backwalls had jogs at each corner). Further, the north corner of the east abutment had separated from the main stem concrete and needed to be replaced. The connecting wingwall was dry-laid stone that had shifted and was on the verge of collapse. A roadway drainage pipe discharged at a point at the beginning of the stone wall and was contributing to its demise. A review of the roadway drainage situation indicated that a cross culvert could be installed in the roadway uphill of the covered bridge abutment. This would allow the removal of a major portion of the stone wingwall and regrading to fill in the ditch in front of the wall. The corner of the abutment was removed and recast on new concrete stepped footings to connect to the rest of the abutment stem concrete.

New thick concrete pads were cast atop both abutments to help knit the combination of original stone and concrete facing together. Backwalls and short wingwalls were then cast with dowels into the main pads. The resulting concrete treatment was economical and should serve well for a long time (refer to figure 208).



Figure 208. Reconstructed east abutment.

Roof Replacement

The bridge had had new wooden shakes installed in the 1980s, but the roof was leaking quite badly. After considering the alternatives, it was decided that the roof should be replaced. Vehicular traffic tends to vibrate a bridge enough to cause snow to slide off faster than bridges closed to traffic. Since this bridge was to remain open only to pedestrian traffic, it seemed prudent to use metal panels rather than wooden shakes or shingles.

Relocation of the Bridge

Without question, the relocation of the bridge garnered the most attention. A pair of steerable dollies was located at each end of the bridge. The power to move the bridge was provided by winches from large wreckers. The roadway is quite steep leading down to the bridge site, and the process involved parking the tractor uphill of the bridge and releasing the cables to their limit, then moving the wrecker to start the process again. The far end of the bridge was hooked to a separate wrecker that provided the steering guidance. It was able to hold the bridge in position with its brakes while the rear wrecker was relocated (refer to figure 209). Upon reaching the low point in the profile, the far wrecker took over and pulled it into place.



Figure 209. Underway on dollies.

The close proximity of the bypass bridge was very convenient, in that the covered bridge on the steerable dollies was pulled across the bypass bridge to align it on the abutments. Then cribbing and skid beams were installed beneath the bridge superstructure to allow it to be winched sideways over the top of the guiderail to the rehabilitated abutments. An interesting challenge involved the relative skew between the two bridges (they are not parallel). Therefore, the end of the bridge closest to the old location was supported on a single heavy roller nest at the centerline of the bridge to allow it to act as a pivot when the other end was winched sideways. In this way, the bridge was moved differentially to align it with its bearing areas. The movers used a swivel roller system beneath each corner at first. Then, to rotate the bridge to accommodate the skew between the respective bridges, the pair of rollers was replaced with a central unit at one end to provide a pivot point.



Figure 210. On top of the bypass bridge—ready to be slid sideways.



Figure 211. Sliding sideways

Once in the proper location, the bridge was too high and had to be lowered into place by a repetitious process of supporting the weight on the jacks and then removing cribbing, then releasing the jacks to the new lower position. The move from the field to the bridge's original location over the river was accomplished by midafternoon. The lowering process was not completed until the following morning.

Appendix E. A Tale of Two Bridges

Speed River Covered Bridge, Guelph, Ontario, Canada

The City of Guelph Parks Department's extensive network of bike and walking trails was the pride of the city of Guelph, Ontario, but it had one major flaw: the Speed River cut the trail system in half, forcing long detours. The city and the Timber Framers Guild struck a deal to solve this problem—at the Guild's first international conference in June 1992, its members would span the river with a pedestrian bridge. And they would do it in style, building a 44-m- (144-ft) long Town lattice covered bridge. The project was notable for several features, including its ambitious construction schedule, crew size, coordination, and innovative frame details.

Contrary to expectation, the 4788 Pa (100 psf) pedestrian live load on the bridge deck proved a more stringent condition than typical highway loading. Fortunately, road width was not an issue in Guelph. Centerline truss-to-truss distance was set at 3.5 m (11 ft, 10 inches), yielding a floor joist span of 3.2 m (10 ft, 4 inches), allowing use of full-size 5 by7 select structural Douglas Fir joists 609 mm (24 inches) on center. The Town trusses measured a relatively deep 4.6 m (15 ft, 1 inch) high (out-to-out on the chords) and used 45° lattice with 3 by11 web members on four foot centers clasped by the typical chord layout: double chords top and bottom, each strand built up of two layers (3 by 10 upper, 3 by 12 lower). Lower chord stock was cut to the maximum length available from the supplier (7.3 m (24 ft)) to minimize end joints in the tension chords. Figures 212 and 213 depict views of the bridge.

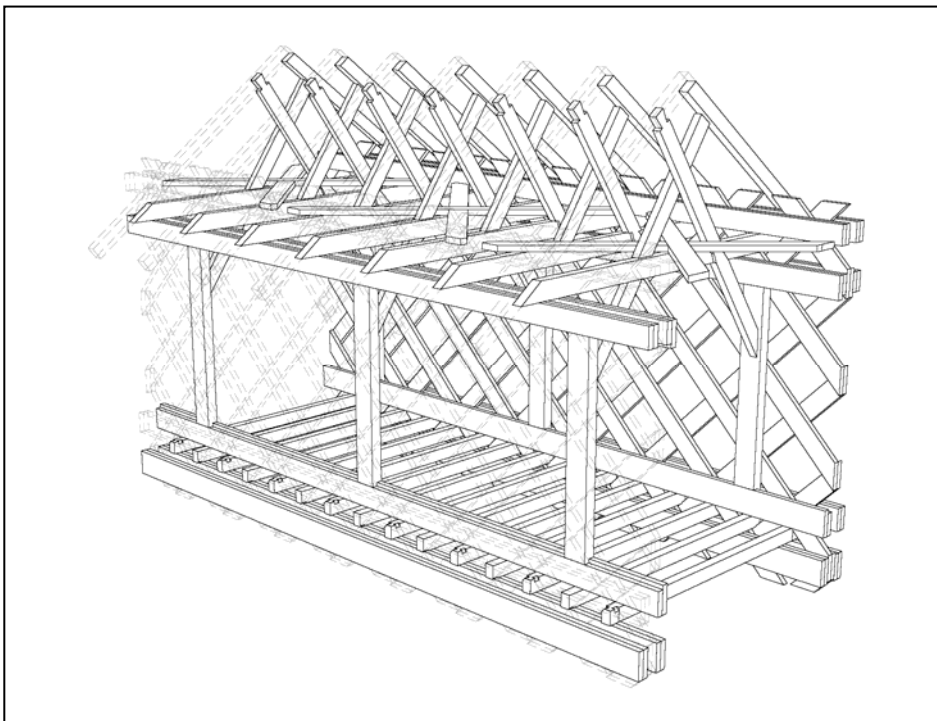

Figure 212. Bridge perspective view.

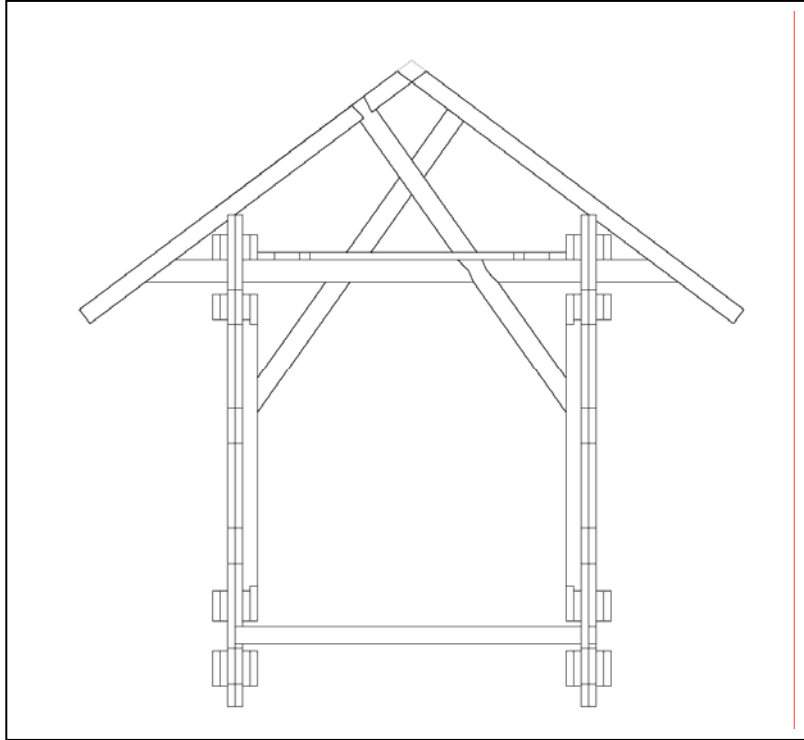

Figure 213. Typical bridge section.

The bottom inside upper chord lams were oversize (3x12), as were their counterparts in the lower chords (top inside sticks at 3x14), creating 3x2-inch grooves running the length of the bridge. These slots received stub tenons on the ends of 12x6 posts set on 3.7-m (12-ft) centers, with the columns also pinned to adjacent lattice crossings, thus fixing them securely to the trusses. The posts, in turn, served as spring points for 4x8 passing braces, with each brace rising to the rafter on the far side, along the way crossing tie beam and opposing brace, yielding four joints per brace:

<u>Location</u>	<u>Connection</u>
Brace-to-Post	Pinned Blind Mortise and Tenon
Brace-to-Tie	Hourglass Half Lap
Brace-to-Brace	Pinned
Brace-to-Rafter	Barefaced Lap Dovetail

This combination of posts woven into the web and passing braces with multiple connections went a long way toward curing the notorious weakness of Town bridges—their tendency to wrack in cross section.

The Guelph project introduced covered bridge construction to many members of the Timber Framers Guild through a unique design and construction process managed by a six-person bridge club. The Guild contracted with the City of Guelph to fabricate the bridge. A professional bridge builder was hired to supervise. Apart from this builder and the small crew, all bridge workers were volunteers, donating their time to the Guild. Canadian authorities had decreed that a cribbing tower could not be built in the river to support temporary girders for a traditional bridge rollout, so two big cranes 227,273 and 363,636 kg (250- and 400-ton) hydraulic) were planned to set the bridge on its abutments. Because cranes could only take the 68,100-kg (150,000-pound) bridge the last few feet, the Guild crew was required to first raise the two 18,160-kg (40,000-pound) trusses, build the floor and roof, then roll the bridge out, cantilevering it over the river for the short flight home. All the building and rigging work was slated to be completed with hand tools over the 5 days of the Guild Conference, a daunting prospect. However, a capable and determined crew of 400 was ready to do the job.

Chords and lattice had been laid down by advance teams before the conference. On the first day, the crew was given 44.45 mm (1.75-inch) pegs to drive, rapidly turning the two 45.75-m- (150-ft) long timber piles into

functioning bridge trusses. To raise the trusses, the crew was divided into pushers and pullers. The former would lift the truss, first by hand, then with the aid of dozens of traditional pike poles. Meanwhile the pullers would do the bulk of the work, hauling on 25.4-mm (1-inch) manila lines reeved through six sets of triple-sheave block and tackle-rigged to temporary derricks built of phone poles loaned for the purpose (see figure 188).

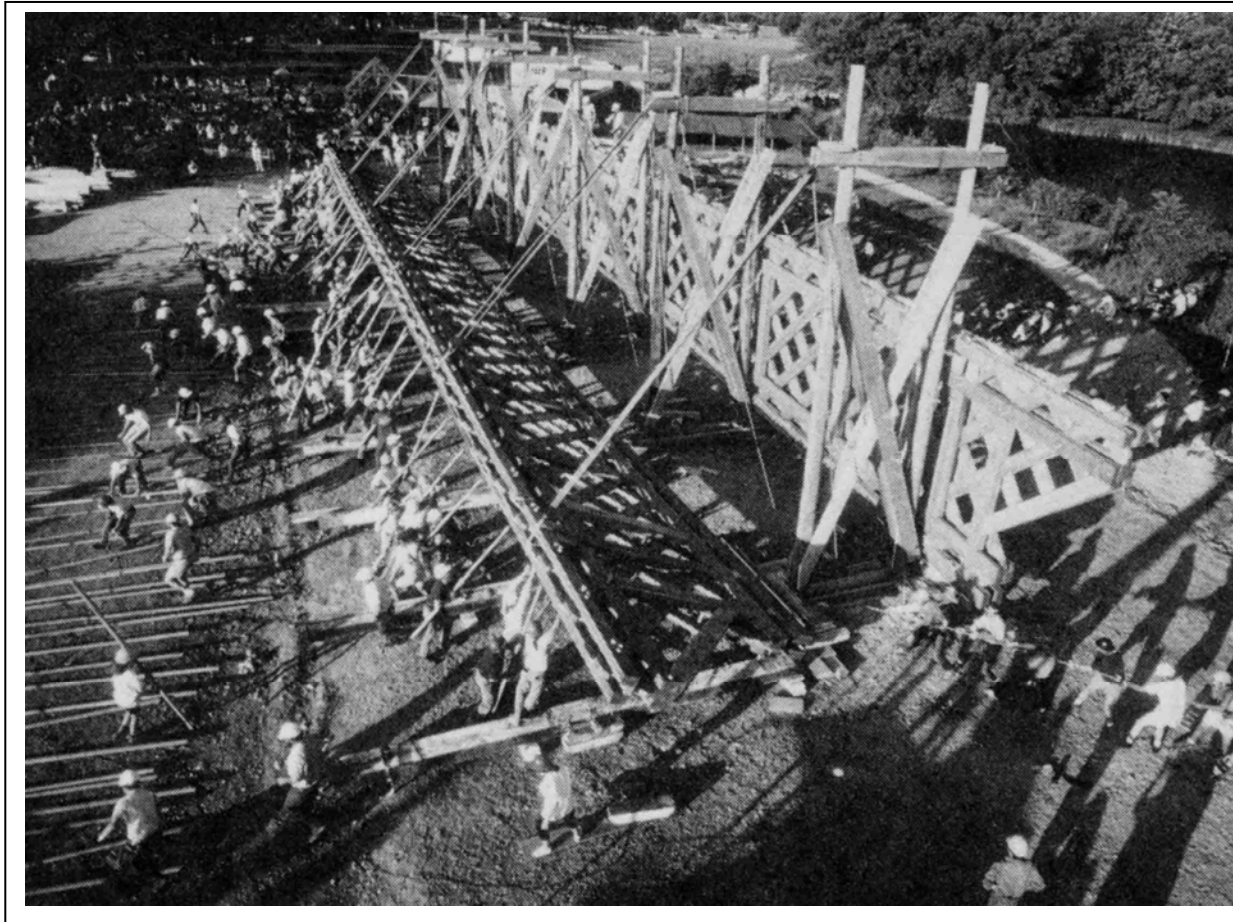

Figure 214. Raising the trusses.

The rising trusses came against the phone poles and were then trued-up plumb, level, and even with each other. Floor joists snaked through the lattice, and two layers of flooring were nailed down at 45° to the joists and 90° to each other (for wind resistance). Meanwhile, teams built and set 15 roof trusses and intermediate X-braced common rafters on 1.2-m (4-ft) centers.

With floor, flooring, and roof structure complete, the bridge was jacked up and rolled toward its moorings on veneer core rollers using rails made from reused blocking, bed timbers, and derrick material with motive power once again supplied by the builders via block and tackle. To save time and weight, installation of roof nailers and shingles was deferred until after the bridge lift. The work was completed on schedule.

After the Speed River Bridge project, many participants have sought additional opportunities for covered bridge construction and preservation, and bridge work is gradually reasserting its status as a staple of the timber frame repertoire.

Twin Bridges, North Hartland, VT

Sometime in the 1880s, a pair of inline Town lattice bridges was built across the Ottauquechee River just above its confluence with the Connecticut River. By taking advantage of an island in Ottauquechee, the builders saved 30 m (100 ft) of bridge. The twin bridges carried traffic along Mill Street until 1938, when the southernmost span was washed away in a hurricane. It was replaced with a steel-and-concrete bridge the following year.

By the mid-1990s, the replacement bridge was at the end of its useful life; girders were badly rusted, and the concrete was spalling away. By contrast, the 100-year-old surviving covered sister still looked and worked like new. The close proximity of and contrast between the two spans made them ideal for a covered bridge revival, illustrating the advantages of covered bridges when measured by longevity, life cycle cost, environmental impact, resource efficiency, and beauty. The people of Hartland, VT wanted a new covered bridge, and the Vermont Agency of Transportation had scant basis for objection, because the Mill Street neighborhood was already accessed via covered bridge.

The new span would emulate the surviving lattice bridge. Its relatively short span (19.8 m (65 ft) clear, 24.7 m (81 ft) overall) and tall trusses (4.9 m (16 ft) outside chord height¹) meant that there was no question as to the adequacy of the trusses. On the other hand, AASHTO HS 15 highway loading presented a challenge, given the 5.2-m (17-ft) joist clear spans. To meet this standard, 7x14 select structural hickory joists were specified, 0.6 m (2 ft) on center, with 10x4 select structural oak or hickory planking secured with 63.5 mm by 203.3 mm (2.5 inch by 8 inch) lag bolts per plank per joist.

The builder adopted a novel strategy to counter wracking, using 16 Larch ship's knees spaced at 3.7-m (12-ft) intervals, bolted and shear-block to upper chords and tie beams, stiffening the bridge without obstructing vehicle passage (see figure 215). Note the ship's knees in the photo; these increased inside clearance, while still providing a good bracing element.

¹Average net vertical clearance in Vermont covered highway bridges is just under 3.6 m (12 ft). At North Hartland, vertical clearance is 4.1 m (13.5 ft).

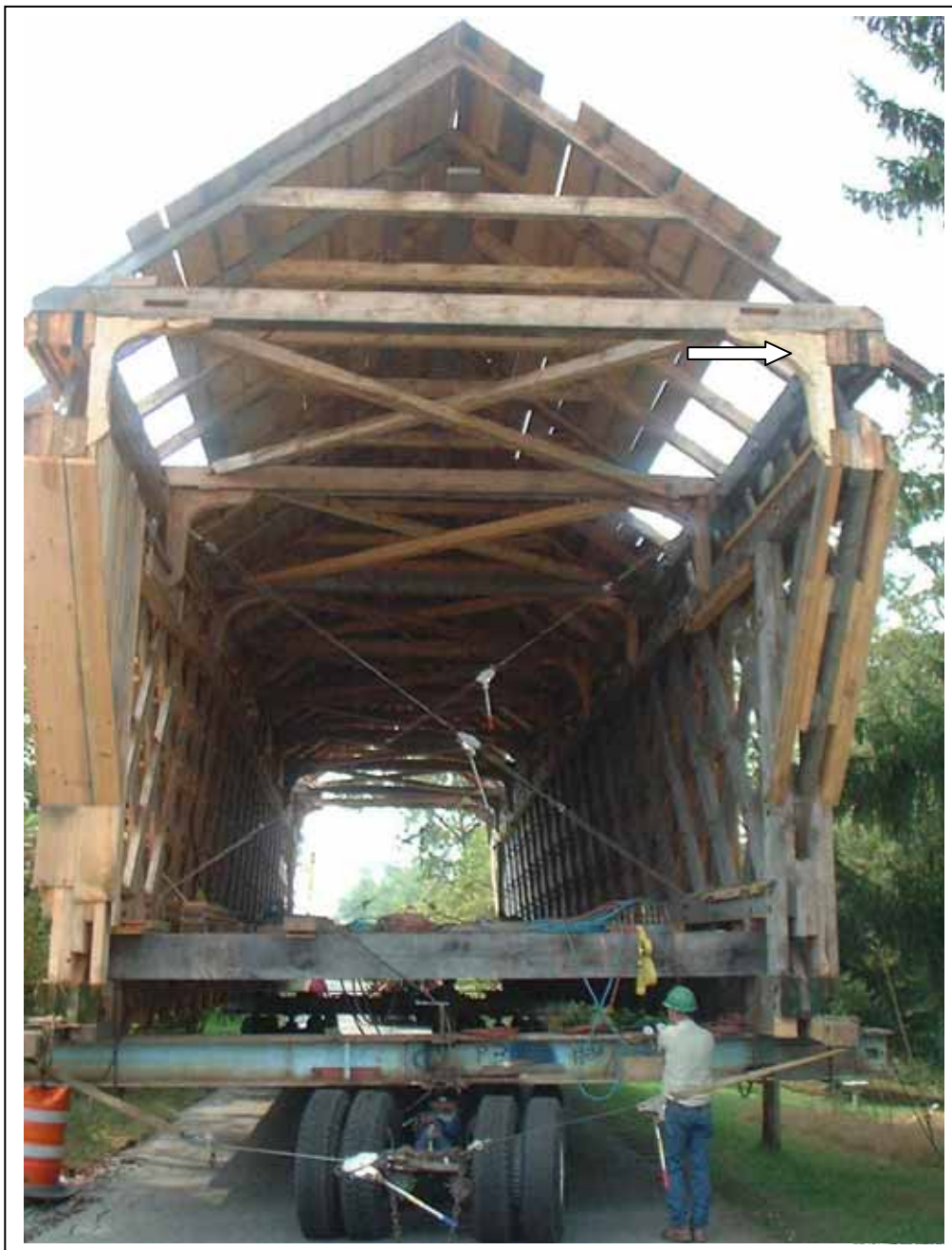

Figure 215. Hartland Bridge on the move.

The project was scheduled for construction during the summer of 2000, but delays in upgrading the abutments postponed completion to the following year. Having already obtained much of the spruce timber for the trusses, the builder did not want to let it sit and twist, and secured permission to assemble the bridge frame in the town park a quarter of a mile from the river crossing. In August of 2001, the completed span (without the roof) was rolled down the road and set in place (see figure 216).



Figure 216. Observers watching a bridge move past.



Figure 217. Bridge in place awaiting final lowering.

Appendix F. Smith Covered Bridge Over the Baker River

Introduction

The Smith Covered Bridge over the Baker River in Plymouth, NH, is a traditionally framed, two-lane-wide timber covered bridge that is designed for AASHTO HS20 loading. It was constructed in 2000-2001, and it is located on the site of a load-posted, one-lane covered bridge that was built in 1850 and destroyed in an arson fire in 1993. The decision to replace the old bridge with the new covered bridge was a compromise between local sentiment for replicating the old bridge and the need for a two-lane bridge without load posting as determined by the New Hampshire Department of Transportation (NHDOT). NHDOT selected a consultant design team, and the project followed the typical design-bid-build process.

Bridge Dimensions and Details

- Overall bridge length: 53.7 m (176 ft).
- Clear span length: 45.75 m (150 ft) (3 m (10 ft) greater than old bridge to increase hydraulic opening).
- Clear roadway width: 7.3 m (24 ft) (between faces of railing).
- Outboard sidewalk width: 1.5 m (5 ft) (sidewalk on downstream side only).
- Out-to-out roof width: 14.6 m (48 ft).
- Vertical roadway clearance: Varies from 5.5 m (18 ft) at portal peak to 4.4 m (14.5 ft) at face of railing.
- Height from roof peak to bridge deck: 9.5 m (31 ft).
- Main support system: Long trusses with supplemental arches.
- Truss configuration: 14 truss panels, 3.5-m (11.5-ft) panel length, 6.7-m (22-ft) panel height (center-to-center of chords).
- Design live load: AASHTO HS20 truck.

Main Truss and Arch Configuration

The new bridge has many similarities with the old bridge, but it is also different in many ways. The main trusses of the old bridge were in general accordance with some of Stephen Long's 19th century patents and were assisted by supplemental arches, as are the new trusses. The arches of the new bridge are sandwiched within the truss plies similar to the method used in the Blenheim Covered Bridge that was designed by Nichols Powers in 1854. (Blenheim Covered Bridge is a double-barrel bridge that is considered to have the world's longest span for a covered bridge). In this way, the arches and trusses can share the burden of carrying the gravity loads. In contrast, if arches are fastened to the sides of the trusses, (as is typical of Burr arch/truss design and as was done in the old bridge because those arches reportedly added a few years after the initial construction), then it is much more problematic to ensure adequate load sharing.

For the new bridge, truss depth is dictated by the geometric design parameters of an arched portal opening and a 4.4-m (14.5-ft) minimum clear height for the full 7.3-m (24-ft) deck width. The combination of truss depth, span length, and design loading requires very large trusses. As a result, structural glue-laminated timbers (also known as glulam) have been used for the truss members. In contrast, if solid-sawn timbers had been used, then the truss members would have been much heavier and larger in cross section due to the greater variability and generally lower reliable strength of solid-sawn timber compared to glulam. The trusses of the new bridge are relatively deep and thick for a covered bridge carrying roadway traffic, and in this respect they are more akin to the large timber trusses that were used in the past for some railroad bridges.

In most cases, joinery details of the new bridge use shouldered wood connections and hardwood wedges. This is evident in the main trusses and is consistent with Long's patents. Use of modern metal fasteners for the truss node connections was not feasible, because there was not enough room to squeeze in the many fasteners that would have been required. In most cases, bottom chord splices are in general accordance with Long's ideas.

Design of the areas where the arches pass through the bottom chords was particularly problematic. In these areas, sistered timbers and split ring shear connectors provide continuity to the second and third chord plies. The floor beam in this area cannot extend over all four-chord plies due to arch interference, so a steel fabrication is used to transfer the floor beam reaction into the arch without distressing the innermost chord ply. The sidewalk framing is also more complicated in this area because of the shortened floor beam.

Floor System Configuration

Roadway width and design live loading dictated the 762-mm (30-inch)-deep glue-laminated timber floor beams. Solid sawn timber floor beams were not feasible for the bridge due to the required floor beam depth. The floor beams rest on top of the bottom chords and are located at the quarter points of the truss panels (i.e., 1.75-m (5.75-ft) spacing on center). The glulam deck is 171.45 mm (6.75 inches) thick and has a 76.2-mm (3-inch)-thick oak plank wearing surface.

Superstructure Materials

All truss, arch, floor beam, deck, and lateral bracing members are glulam timbers manufactured from Southern Pine. Roof framing and most other miscellaneous wood members are solid-sawn Southern Pine timber or lumber. Southern Pine was selected because of its relatively high strength and because of its ability to receive pressure preservative treatment without the need for incising. All main wood framing components below the level of the roof eaves were pressure preservative treated with pentachlorophenol. The wood siding is single layer vertical board siding on the sides and horizontal clapboard siding on the portals. The roof surface is corrugated metal, and it is supported by 4x4 lumber purlins that are fastened on top of the rafters. To reduce the potential for destruction by fire, a fire detection and alarm system has been installed, and much of the superstructure has received fire retardant clear coating.

Substructure Configuration

The substructures consist of pile supported, reinforced concrete abutments with 0.3-m (1-ft)-thick ashlar granite facing. The abutments not only support the gravity loads of the superstructure, but also the horizontal loads from arch thrust. The granite facing was added to match the appearance of the original abutments, one of which has been preserved immediately adjacent to the new bridge. The deep bedrock and sandy soils at the bridge site necessitate the many long battered friction piles to reduce the potential for scour problems and foundation movement.

Superstructure Fabrication and Erection

Detailed shop drawings showing all wood fabrication notches, mortises, tenons, and fastener holes were prepared for each glulam member. Most of the many required notches, holes, etc. were made in the glulam fabrication plant. Portions of the superstructure were temporarily assembled at the fabrication plant to ensure proper fit. Individual pieces were then transported to the site and reassembled in place on false work that was erected in the river. Most of the members were brought in a piece at a time using overhead cranes.

Construction Costs

The total construction cost for the project was approximately \$3.1 million. This included the superstructure, substructures, and approximately 915 m (3,000 ft) of realigned/reconstructed two-lane highway. The cost of the superstructure alone (materials and installation) was approximately \$1.5 million. This included approximately \$1.4 million for the approximately 225,000 board feet of wood materials.

Project Photographs



(photo provided courtesy of Ryan-Biggs Associates, P.C.)

Figure 218. Overall view of bridge showing overhanging portal, metal roof, outboard sidewalk, main truss, and arch visible through open side, and granite-faced abutment.



(photo provided courtesy of Ryan-Biggs Associates, P.C.)

Figure 219. Main truss and arch during construction showing shouldered and wedged timber connections.



(photo provided courtesy of Ryan-Biggs Associates, P.C.)

Figure 220. Underside of bridge showing floor beams, metal deck clips, bottom lateral bracing, arch springing area, and steel fabrication at the location where the arch passes through the bottom chord.

Appendix G. Caine Road Covered Bridge, Ashtabula County, OH

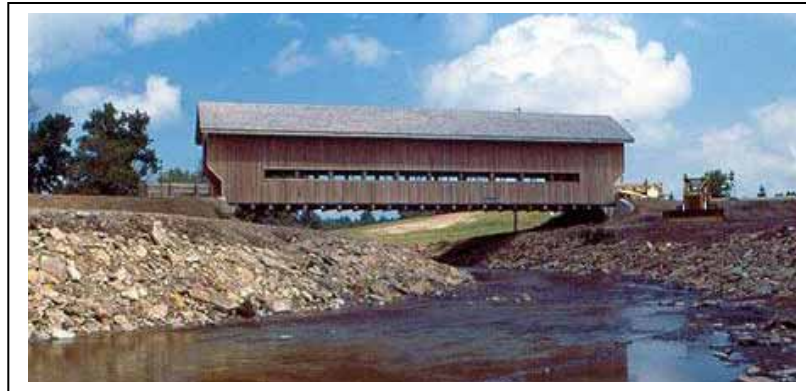

Figure 221. Final bridge.

As a part of its 175th birthday celebration, Ashtabula County, OH, appropriated \$100,000 to purchase materials for the construction of the county's 14th covered bridge. The new covered bridge replaced an old steel truss bridge. The Ashtabula County Highway Department performed the construction. A Pratt truss design was selected for its efficiency and cost-effectiveness. The Pratt truss construction consists of vertical timber posts, timber chords, and diagonal steel rods. This was the first covered bridge of Pratt truss construction in Ashtabula County.

Caine Road is a township highway with a traffic volume of fewer than 400 vehicles per day. It was determined that a 5.5-m- (18-ft) wide, 4.4-m- (14.5-ft) high, HS20-44 loading bridge would be built.



Figure 222. Existing site with poor alignment.

The first phase of construction was to build new abutments. They are standard stub abutments that bear directly on bedrock. The total height of abutments was 5.2 m (17 ft). Rock channel material would later be placed to provide erosion and scour protection. To correct both stream and highway alignment problems, the decision was made to relocate the new bridge. After the new bridge was built, the stream was relocated to flow under the new bridge.



Figure 223. New abutment construction on new alignment.



Figure 224. New stub abutment stem.

The main trusses were built with Southern Pine glue-laminated lower chords and floor beams. To minimize the number of tension splices in the lower chords, 19.5-m- (64-ft) long timbers were used. Splices consisted of steel plates with bolts and 100-mm- (4-inch) diameter shear plates. The upper chords and verticals were built with solid-sawn Southern Pine. The upper chords were triple metric needed 150x400x7.3m (6"x16"x24') long. Also in the plane of the trusses are metric needed 75x250x2.4m (3"x10"x 8') oak timber diagonals that act as spacers between the elements.



Figure 225. Truss assembly.



Figure 226. Three chord elements.



Figure 227. Adding siding before truss lifting and installation.

All chords and verticals are triple element members with approximately 75 mm (3 inches) between the elements. Twin steel diagonal tension bars pass through the gaps. The diagonal bars range in size from 50-63 mm (2-2.5 inches) diameter. Bearing plates are provided to transmit the load to the chords. Grooves are provided in the chords to resist lateral movement of the plates. The ends of the tension bars are threaded for the tightening nuts.

The floor beams (two per panel) are 220x420x6.7m (8¾"x 16½"x 22') spaced 1.2 m (4 ft) apart. They are hung from the lower chords using two 22mm (7/8") diameter bolts at each end. 150 mm by 230 mm (6"x 8") white oak timbers are attached on the floor beams and run longitudinally at a 405-mm (16-inch) spacing. The next layer consists of 75-mm- (3-inch) thick transverse white oak planking. 2" thick oak runners were used to smooth out the ride in the bridge.

The roof system consists of 7/12 pitch trusses with a 100 mm x 200 mm (4"x 8") upper chords and twin 100 mm x 150 mm (4"x 6") lower chords. The roof truss spacing is 1.2 m (4 ft). Purlins are 75 mm x 100 mm (3"x 4") members spaced at 200 mm (8 inches). Wood shingles were nailed to the purlins.

Sway bracing consists of 100 mm x 250 mm x 3.0 m (4"x10"x10') oak knee braces at 2.4-m (8-ft) spacing. Upper lateral bracing consists of 200 mm x 200 mm (8"x 8") transverse with diagonal cross bars.

For longevity, the main trusses and floor beams were treated to prevent deterioration. All steel hardware was hot-dip galvanized.



Figure 228. North truss in position and secured.



Figure 229. Both trusses erected.



Figure 230. Installation of roof trusses and purlins.



Figure 231. Installation of wood shingles.



Figure 232. Completed bridge.

All photos courtesy of John Smolen

Appendix H. Replacement of the Mill Covered Bridge, Tunbridge, VT



Figure 233. Original view.



Figure 234. Destroyed March 4, 1999.



Figure 235. View in December, 2002.

Mill Bridge at Tunbridge, VT

A covered bridge was constructed over the first branch of the White River in the heart of the Village of Tunbridge, VT, in 1883. The single-lane structure was supported by multiple kingpost trusses and was approximately 22 m (72 ft) long (see figure 236). Unfortunately, the bridge was struck by ice on March 4, 1999, and collapsed the following day.



Figure 236. A view of the original bridge

The community wanted to replace the bridge with another covered bridge, and the Vermont Agency of Transportation supported the project by providing the bulk of the funding for the new bridge.

The design criteria for the project included a stipulation for a design vehicle of a single 13.5-MT (15-ton) truck (a convenient bypass exists for heavier vehicles). Further, the trusses were to be built of local native Hemlock, if possible, with similar sizes and configuration as the original bridge. Unfortunately, the design stresses resulting from using the original member sizes would have required select structural Hemlock. Although some local timber sawyers were confident that they could provide acceptable good quality timber, a lumber grader willing to certify that grade could not be found. Accordingly, it was concluded that local Hemlock in the grading necessary was not available. Select structural Douglas Fir was accepted as an appropriate substitute for the critical truss elements.

One unusual detail in the design involved reinforcing the corbels of the vertical posts against shear failure. The details involved inserting four 25.4-mm (1-inch) diameter hardwood pegs in the corbel to provide additional resistance to high shear stresses (see figure 237). According to the analysis of the bridge, the reinforcement was required in only the end three-post elements. Unfortunately, shortly after the bridge was opened to traffic, an overweight vehicle crossed the bridge, contrary to the posted weight restriction, and caused a shear failure in an unreinforced corbel. A steel rod was inserted adjacent to the post as a repair (see figure 238). Figure 239 shows a closeup of the rod connection, and the arrows indicate a slight vertical dislocation along the slip plane. This indicates that it would be wise to reinforce more corbels than required by the design vehicle; the cost was nominal at the time of construction, and the repair was difficult to install with the siding in place and with the bridge located over water.

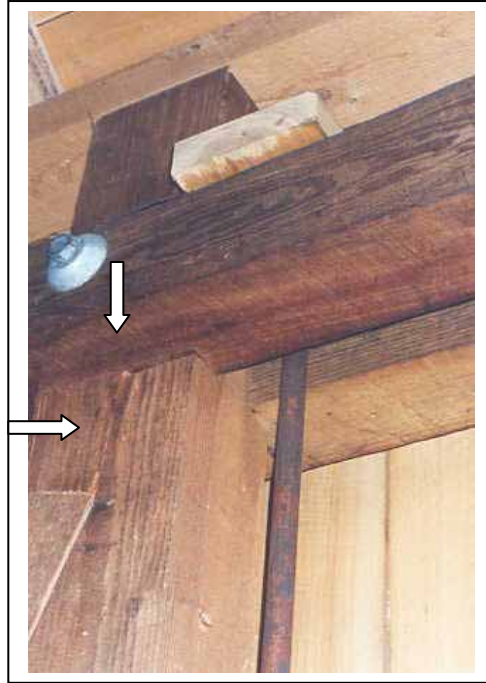

Figure 237. Wooden peg reinforcement of post corbel.



(photo courtesy of Scott Sabol)

Figure 238. Reinforcement rod.



(photo courtesy of Scott Sabol)

Figure 239. Closeup of the failed corbel after the repair.

The bottom chord tensile splices duplicated the use of bar and rod connections, one of several types of tensile connections commonly used in original covered bridge construction (refer to figure 240). This is a view of the original. The replica bridge used a very similar detail.



Figure 240. Bar-and-rod connector tensile splice.

Another important issue related to the bracing of the original bridge. Although the bridge had managed to survive for more than 100 years, the internal bracing was minimal. The contractor sought approval for installation of heavier internal bracing, and permission was granted. New stout tie beams were installed along with heavy knee braces that were connected above the tie beams to form a substantial transverse frame. Timber curbs were installed at 3-m (10-ft) spacing along the bridge to prevent vehicles from impacting the knee braces, a common occurrence at the previous bridge (see figure 241). The gap between curb and approach rail allows pedestrian traffic to pass through the bridge outside of the curb. Note the reflector used at the end of the curb—an effective identifier.

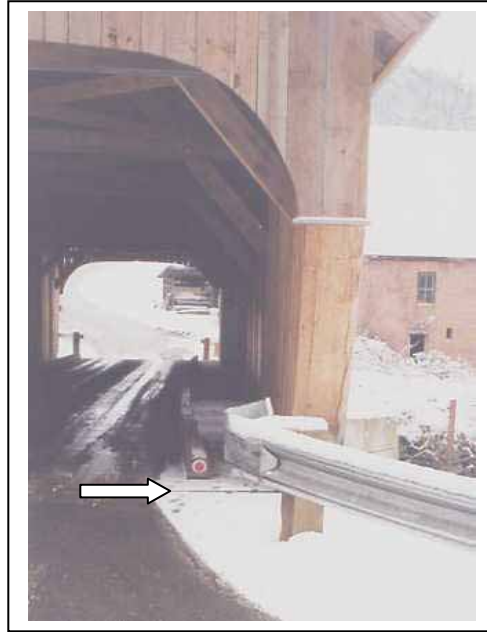

(photo courtesy of Scott Sabol)

Figure 241. Transition from approach rail to inside curb.

The bridge was built on the approach roadway and moved into place with steel rollers supported on two steel I-beams spanning between the abutments. Consistent with the traditions of original construction practices, the power for the relocation of the bridge was provided by oxen turning a capstan (see figures 242 and 243). Figure 244 provides a view of the completed bridge. Note that the windows exist specifically to facilitate traffic crossing through the bridge from the far side to help users see the sharp roadway curve on this side.



Figure 242. Bridge being moved into position.



Figure 243. Oxen power and capstan.

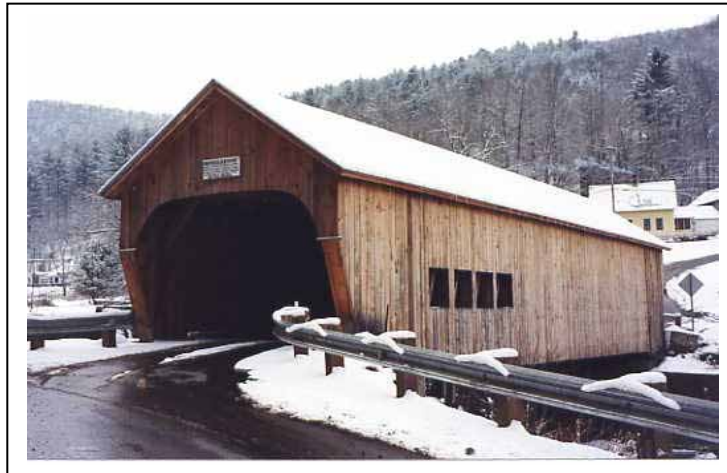

(photo courtesy of Scott Sabol)

Figure 244. Completed bridge.

Appendix I. Rehabilitation of the Paper Mill Covered Bridge, Bennington, VT



Figure 245. New pad at East Abutment—truss erection underway.



Figure 246. Entrance of completed bridge.

The Paper Mill Covered Bridge was built over the Walloomsac River a few miles north of Bennington, VT, in 1889. The 38.1-m- (125-ft) long Town lattice truss supported bridge was built with unusually shallow trusses, compared to the many other Town lattice truss bridges in the area. It is unknown if the bridge had repairs earlier, but extensive reconstruction of the bridge was undertaken in 1952. Again suffering from distress, the bridge was bypassed in the 1980s but continued to serve pedestrian traffic. Finally, in the mid-1990s, continuing deterioration required installation of substantial interior bracing to stabilize the bridge until major rehabilitation could be undertaken. Figure 247 depicts a view of the bridge before the recent work. Note the substantial horizontal wave of the top chord, indicating serious distress.

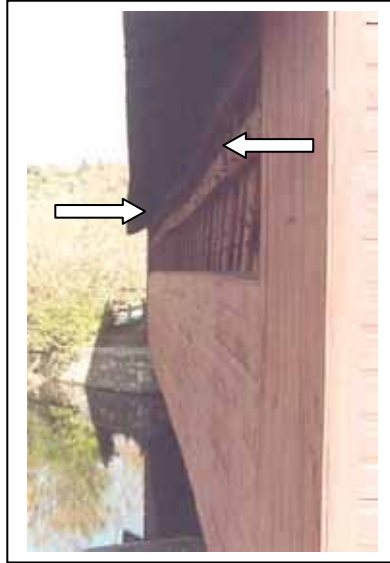

Figure 247. The bridge before work.

The initial study had identified major rot of the top chord on the upstream truss, as a result of long-term leakage through a hole in the roof. (The roof of the bridge was used by local residents as a diving platform into the adjacent swimming hole of the millpond; the hole provided access to the roof from inside the bridge.)

The repair work in the 1950s included disassembling the trusses and replacing many members. Unfortunately, the reassembly of the bottom chord included inserting split ring connectors in the middle of the trunnel patterns. The resulting section loss of the main elements reduced their capacity to such an extent that they were unable to safely support even the self-weight of the bridge, much less any snow or pedestrian/vehicle loading.

The work on the bridge was intended to restore its capacity for support of vehicular loading so that the temporary bypass structure could be removed. The design criteria for the project, as provided by the Vermont Agency of Transportation, included a single 18MT (20-ton) truck.

As a consequence of the well-intentioned, albeit damaging, previous installation of split ring connectors in the bottom chord/lattice intersections, salvaging the otherwise undamaged lattice elements was impractical. All of the bottom chord elements were theoretically unable to support their loads, even if in good condition. The top chords had been so overloaded that they were badly distorted and bowed, making their retention impossible. Accordingly, following significant debate and consultation among various involved parties, the decision was made to completely replace the trusses. A few of the original lattice elements were retained at the ends of the trusses where they are terminated above the bottom chord, and are thereby not affected by the section removal from the split ring connectors.

The bridge owner wanted to retain the original geometry of the trusses. While this produced a replica bridge that, to the lay observer, resembles the original, it nonetheless introduced a structural weakness, in that the depth of the bridge would benefit from an increase to lessen the loads in the chords.

The structural analysis of this replica included a very sophisticated finite-element analysis. In addition to the basic force analysis of the lattice and chord elements, it also included a review of the shear stresses in every shear plane of every trunnel group at each chord/lattice or lattice/lattice intersection. The use of solid-sawn timbers required 4x14 select structural Southern Pine bottom chord elements to replace the original 3x12 members. Four 51-mm (2-inch) diameter oak pegs were used for the bottom chord connections at each lattice intersection.

The shallow depth of the trusses caused higher chord forces, thereby requiring substantial overhead bracing. The traditional timber knee braces between the sides of the lattice elements to the underside of the tie beams

were augmented with longer elements beside and above the knees (see figure 248) to strengthen the overhead system. The older, shorter elements were bolted to the side of the longer extensions. The extensions above the tie beams were joined at the peak.



Figure 248. Modified knee braces.

The lattice trusses were built flat, as is typical. When they were complete, the trusses were moved into position using cranes and a flatbed truck that was able to traverse the adjacent bypass bridge before it was removed (refer to figure 249).



Figure 249. Cranes and truck positioning the trusses.

The floor system is comprised of glue-laminated floor beams (nominal 250 mm by 380 mm) (10 inches by 15 inches) at 1.2-m (4-ft) spacing with 150-mm (6-inch) nominal thickness glue-laminated panels. New concrete-bearing seat caps were cast on top of the existing dry-laid stone abutments.

Work began in November, 1999, and construction was completed and the bridge reopened to traffic on July 13, 2000 (see figure 250).



Figure 250. Bridge following reopening.

Appendix J. Replacement of the Power House Covered Bridge, Johnson, VT



Figure 251. Opening day parade.



Figure 252. Completed replacement truss.

The Power House Covered Bridge was constructed in 1870 over the Gihon River in Johnson, VT, to connect School Street with what is now Route 100C (see figure 253). The structure was supported by queenpost trusses with a total length of about 22.2 m (73 ft). Unfortunately, the trusses have experienced significant distress for many years, and the bridge was rebuilt on numerous occasions. In 1995, further work was performed to remove the timber floor from the trusses and install an independent floor system of timber deck on steel beams supported directly on the abutments.



Figure 253. Bridge before collapse.

On March 8, 2001, the covered bridge shell collapsed under the weight of heavy snow (see figure 254). The failure of the roof structure pushed the tops of the trusses outward, and they rotated until they ended up in the stream. The existing deck structure remained intact and undamaged.



Figure 254. Bridge after collapse from snow.

The community decided to rebuild a replica of the shell of the bridge, but wanted to keep the independent floor system. Therefore, the new shell did not have to be designed to support vehicular loading, but did have to support snow loading. The collapse demonstrates that snow loading can be significant.

Design and construction activities took place during 2002.

Before collapse, the bridge contained a bottom chord of three sticks, an unusual arrangement and difficult to join to the single plane of verticals and diagonals. It is unknown if this was the original arrangement or installed during one of the repairs. There are several other queenpost truss covered bridges in the vicinity. A review of the details of those bridges indicated that two chord sticks were common; this accommodates an easier connection to the diagonals and verticals. Therefore, the pair concept was adopted for the replica (refer to figure 255). The photograph shows the conventional tabled joints to the posts and a scarf joint in the near bottom chord element.



Figure 255. Double bottom chord arrangement with scarf joint.

The lack of significant overhead bracing was a major cause for the collapse. Accordingly, a stronger system was installed, similar to that used in the Mill Bridge, described in appendix H.

Wind loading bows the bottom of the sides of the bridge, because there is no deck to serve as a diaphragm. Therefore, a connection between the sides of the covered bridge and the existing timber deck/steel beam

superstructure was deemed appropriate. The deflection of the floor system under vehicular loading is accommodated in the connection to the timber shell. Horizontal restraint is therefore required, in combination with vertical freedom (see figure 256).



Figure 256. Connection between deck and bottom chord.

The trusses had to be designed for their own weight and the weight of snow. Although the trusses do not support vehicular loading, the effect of snow loading was substantial, and the truss components were selected to match the previous sizes as closely as possible. Because the shell structure does not receive vibrations from passing vehicles, it was decided that metal roofing would be used to minimize the potential for heavy snow drifting on the bridge.

The heel connection of queenpost trusses is a critical feature. The other queenpost bridges in the vicinity of this bridge provide a number of different arrangements for the connection. Figure 257 presents details of the connection selected for this installation. The diagonal at the top left is notched into the top of the bottom chords. The post is tabled into the chord. The smaller element on the end is a support for the siding, and is not a part of the truss.



Figure 257. Heel connection details.

A queenpost truss feature that provides a slightly different challenge is the support of the rafters. In this bridge, a rafter plate is situated above the top chord and extends the full length of the bridge. The tie beams are connected to the tops of the posts, but unlike most situations, were located in the same plane of the rafter plate. This requires an unusual three-way connection (see figure 258).



Figure 258. Connection of tie beam, truss vertical, and rafter plate.



Figure 259. Final product.

ACKNOWLEDGMENTS

The following people made contributions to this manual:

Messrs. Robert L. Brungraber, Abba Lichtenstein, and Scott Sabol provided reviews, consultations, and improvements.

Dr. Brungraber provided extensive and important contributions to the chapter on timber connections.

The Vermont Agency of Transportation, and Warren Tripp in particular, for his leadership of the Statewide Covered Bridge Study and follow-up covered bridge rehabilitation projects, which were important for compilation of this manual.

McFarland-Johnson, Inc., for permission to use the information and photographs gleaned from the Statewide Study of Covered Bridges in Vermont and the follow-up rehabilitation projects at Paper Mill and Hopkins Bridges. Shumaker Consulting Engineering and Land Surveying, Inc., for permission to use the information and photographs related to the Mill Bridge project in Vermont.

The Delaware County Department of Public Works for information and photographs related to rehabilitation of the three publicly owned covered bridges in the County—Downsville, Hamden, and Fitch's.

Joe Nelson for permission to use photographs from his covered bridge Web site (www.vermontbridges.com) and his modification of figures from his book, *Spanning Time - Vermont's Covered Bridges*, to highlight special features and use terminology consistent with this manual.

Duncan McElroy for preparation of the connection figures presented in chapter 14.

Robert Canham, Ed Levin, and John Smolen for their preparation of articles about new covered bridge construction presented in the appendices of this manual.

Dann Hall and his software development firm for the ongoing support with refined computerized analysis on multiple covered bridge projects.

Joseph Conwill for review of chapters 2 and 3 to improve the accuracy of these brief summaries.

Tara Jendrzewski for reformatting the references listed in Chapter 20.

Caroline Brown, Ed Barna, and Jim Smedley for permission to use their photographs herein.

The following people provided valuable reviews of the manual:

Neil Daniels, P.E., Ascutney, VT.

Eric DeLony, Chief, Historic American Engineering Record, Washington, DC.

Dario Gaspirini, P.E., Professor of Civil Engineering, Case Western Reserve University, Corvallis, OR.

Jan Lewandoski, Greensboro Bend, VT.

Paul Liles, Jr., P.E., Georgia Department of Transportation, Atlanta, GA.

REFERENCES AND OTHER RESOURCES

References

Other Resources



Figure 260. Power house replica, Johnson, VT.



Figure 261. Old Stone Fort Bridge, Schoharie County, NY.

References

1. *World Guide to Covered Bridges*, B. Heisel, ed., The National Society for the Preservation of Covered Bridges, Inc., 1989.
2. *Standard Specifications for Highway Bridges*, the American Association of State Highway and Transportation Officials (AASHTO), 17th Edition, 2002.
3. National Design Specifications for Wood Construction and Supplement: Design Values for Wood Construction, American Forest and Paper Association, 2001.
4. Ritter, Michael, *Timber Bridges—Design, Construction, Inspection, and Maintenance*, U.S. Department of Agriculture, U.S. Forest Service, 1992.
5. James, J.G., “The Evolution of Wooden Bridge Trusses to 1850,” *Journal of the Institute of Wood Science*, United Kingdom, Vol. 9, Nos. 3 & 4, Issues 51 & 52, June and December 1982.
6. James, J.G., “The Evolution of Wooden Bridge Trusses to 1850,” *Covered Bridge Topics*, National Society for the Preservation of Covered Bridges, Inc., 1997 and 1998.
7. Foliente, G.C. and T.E. McLain, “Design of notched wood beams,” *Journal of Structural Engineering*, Vol. 118, No. 9, 1992, 2407-2420.
8. *Minimum Design Loads for Buildings and Other Structures*, American Society of Civil Engineers, Reston, VA, 2002.
9. *Timber Construction Manual*, American Institute of Timber Construction, Wiley-Interscience, 1994.
10. *Wood Handbook*, U.S. Department of Agriculture, U.S. Forest Service, 1999.
11. Goldstein, E., *Timber Construction for Architects and Builders*, McGraw-Hill, 1999.
12. Guide Specification for Design of Pedestrian Bridges, AASHTO, 1997.
13. Commentary on the National Design Specifications for Wood Construction, American Forest and Paper Association, 1991.
14. McCormac, J.C., *Structural Steel Design*, International Textbook Company, Scranton, PA, 1969.
15. Hool, G. A. and W.S. Kinne, *Steel and Timber Structures*, McGraw-Hill Book Company, Inc., New York, NY, 1924.
16. Grāton, M.S. *The Last of the Covered Bridge Builders*, Plymouth, NH, Clifford-Nicol, Inc., 1990.
17. Fletcher, R. and J.P. Snow, “A History of the Development of Wooden Bridges,” *American Wooden Bridges*, American Society of Civil Engineers, New York, NY, 1976, 29-69.
18. Brungraber, Robert L., *Traditional Timber Joinery: A Modern Analysis*, Diss. No. 86 02 458, University Microfilms International, Ann Arbor, MI, 1985.
19. Schmidt, Richard J. and Christopher E. Daniels, Design Considerations for Mortise and Tenon Connection, A Report on Research Sponsored by the USDA NRI/CGP Washington, DC and Timber Frame Business Council, Hanover, NH, April 1999.
20. *Manual for Condition Evaluation of Bridges*, American Association of State Highway and Transportation Officials, 2nd Edition, 1994.

21. "Manual for Bridge Rating through Load Testing," *NCHRP Research Results Digest Number 234*, NCHRP, 1998.
22. *Book of Standards*, American Wood Preservers Association, Granbury, TX, 2001.
23. Best Management Practices for the Use of Treated Wood in Aquatic Environments, Western Wood Preservers Institute, Vancouver, WA, 1996.
24. Ritter, M.A. and S.A. Duwadi, *Research Accomplishments for Wood Transportation Structures Based on a National Research Needs Assessment*, General Technical Report FPL-GTR-105, U.S. Department of Agriculture, U.S. Forest Service, Madison, WI, 1998.
25. *Environmental Impact of Preservative-Treated Wood in a Wetland Boardwalk*, Research Paper FPL-RP-582, U.S. Department of Agriculture, U.S. Forest Service, Madison, WI, 2000.
26. Morrell, J.J. and R. Rhatigan, "Preservative Movement from Douglas Fir Decking and Timbers Treated with Ammoniacal Copper Zinc Arsenate Using Best Management Practices," *Forest Products Journal*, 50(2), 2000, 54-58.
27. Brooks, K.M., An Assessment of the Environmental Effects Associated with Bridges Constructed of Wood Preserved with Creosote, Pentachlorophenol or Chromated-Copper-Arsenate, Research Paper FPL-RP-587, U.S. Department of Agriculture, U.S. Forest Service, Madison, WI, 2001.
28. Harp, K.L and S.L. Grove, "Evaluation of Wood and Soil Samples from Copper Naphthenate Treated Utility Poles in Service," *Proceedings*, American Wood Preservers Association; Vol. 89, 1993, 167-191.
29. Preston, A.F., P.J. Walcheski, P.A. McKaig, and D.D. Nicholas, "Recent Research on Alkylammonium Compounds in the U.S.," *Proceedings*, American Wood Preservers Association, Vol. 83, 1987, 331-348.
30. Chapman, J.S., M.A. Diehl, K.B. Fearnside, and L.E. Leightly, *Antifungal Mechanism of Dichloro-N-Octylthiazolone*, IRG/WP 98-30183, International Research Group, Stockholm, Sweden, 1998.

Other Resources

This section lists books about covered bridges. The books in the first subsection are primarily nontechnical and may have relatively little information of interest to engineers or builders; however, a chapter on references would be remiss in not including this information.

A second subsection lists more technical material about covered bridges. A few of the many reference books on timber are included; this list is by no means exhaustive. Some of the articles prepared by early bridge builders also are included, although this material may be difficult to find.

A third subsection lists articles related to timber bridges. Most of these articles have been prepared in the past 10 years, with a few older articles interspersed. This list is not exhaustive, but represents those identified as relevant to this manual.

A fourth subsection is devoted to other sources of information.

Nontechnical Covered Bridge Information

Adams, K., *Covered Bridges of the West—History and Illustrated Guide*, Washington, Oregon, and California, Howell-North Books, Berkeley, CA, 1963.

Allen, R., *Covered Bridges of the Middle Atlantic States*, Stephen Greene Press, Brattleboro, VT, 1959.

Allen, R., *Covered Bridges of the Middle West*, Stephen Greene Press, Brattleboro, VT, 1970.

Allen, R., *Covered Bridges of the Northeast*, Stephen Greene Press, Brattleboro, VT, 1957 (and revised edition 1983).

Allen, R., *Covered Bridges of the South*, Bonanza Books, New York, NY, 1970.

Allen, R., *Old North Country Bridges*. North Country Books, Utica, NY, 1983.

Allen, R., *Rare Old Covered Bridges of Windsor County*, Book Cellar, Brattleboro, VT, 1962.

Anderson, S., *Guide to the Covered Bridges of New York State*, Kingston, NY, 1962.

Anderson, S., *Ulster County's Old Timbered Crossings*, Kingston, NY, 1964.

Auvil, M., *Covered Bridges of West Virginia, Past and Present*, McClain Printing, Parsons, WV, 1973.

Baker, J., *An Undercover Story: Covered Bridges of California*, Chapel Hill Press, Chapel Hill, NC, 2000.

Barkman, S., *Covered Bridges of Somerset County, Pennsylvania*, A-Accurate Printcrafters, Bradenton, PA, 1979.

Barna, E., *Covered Bridges of Vermont.*, Countryman Press, Woodstock, VT, 1996.

Barton, E., *The Covered Bridges of Columbia County, Pennsylvania*, Columbia County Historical Society, Bloomsburg, PA, 1962 and 1974.

Brandenburg, D. and P. Brandenburg, *Kentucky's Covered Bridges*, Harvest Press, Cincinnati, KY, 1968.

Brydon, N., *Of Time, Fire and the River—The Story of New Jersey's Covered Bridges*, Essex Falls, NJ, 1971.

Caravan, J., *American Covered Bridges—A Pictorial History*, Courage Books, Philadelphia, PA, 1995.

Caruthers, E., *Seeing Lancaster County's Covered Bridges*, 1974.

- Chapman, B. and R. Leavitt, *50 Old Bridges of Lebanon, New Hampshire*, Lebanon Historical Society, Lebanon, NH, 1975.
- Cockrell, N. and B. Cockrell, *Roofs Over Rivers—A Guide to Oregon's Covered Bridges*, Touchstone Press, Beaverton, OR, 1978.
- Cockrell, N. and B. Cockrell, *Roofs Over Rivers—The New Guide to Oregon's Covered Bridges*, Oregon Sentinel, Salem, OR, 1989.
- Cohen, S., *West Virginia's Covered Bridges—A Pictorial Heritage*, Pictorial Histories, Charleston, WV, 1992.
- Coldrick, H., *New Brunswick's Covered Bridges*, Neptune, Saint John, New Brunswick, 1999.
- Congdon, H., *The Covered Bridge*, Vermont Books, Middlebury, VT, 1959-1989.
- "Covered Bridge Festival," The Columbia-Montour Tourist Promotion Agency, 1976.
- Covered Bridges in the Province de Quebec*, Canadian Department of Tourism, Fish, and Game, 1964.
- "Covered Bridges In Windham County, Vermont," *The Brattleboro Daily Reformer* and the *Vermont Phoenix*, 1937.
- Covered Bridge Pictorial Review*, Ashtabula County Historical Society, Vol. 15, 1968.
- De Vito, M., *Connecticut's Old Timbered Crossings*, De Vito Enterprises, Warehouse Point, CT, 1964.
- Dedication Souvenir Booklet of the Covered Bridge at Perkasio, PA, 1959.
- Eaton, T., *The Covered Bridges of Illinois*, Edward Brothers, Ann Arbor, MI, 1968.
- Evans, B. and J. Evans, *Pennsylvania's Covered Bridges*, University of Pittsburgh, PA, 1993.
- Georgia's Romantic Bridges*, Public Information Office, Georgia Department of Transportation, 1980.
- Gill, P., "Drive the Road and Bridge the Ford" *Highway Bridges of Nineteenth Century, Cumberland County*, Cumberland County Historical Society, Carlisle, PA, 1992.
- Gillis, S. and J. Gillis, *No Faster Than A Walk—The Covered Bridges of New Brunswick*, Goose Lane Editions, Fredericton, New Brunswick, 1997.
- Gould, G., *Indiana Covered Bridges Thru the Years*, Indiana Covered Bridge Society, Indianapolis, IN, 1977.
- Gratōn, M., *The Building of Zehnder's Holz-Brucke*, Clifford-Nicol, Inc., Plymouth, NH, 1980.
- Gratōn, M., *The Last of the Covered Bridge Builders*, Clifford-Nicol, Inc., Plymouth, NH, 1980.
- Hagerman, R., *Covered Bridges of Lamoille County*, Hagerman, Morrisville, VT, 1972.
- Harlow, L., *Covered Bridges Can Talk!*, Wake-Brook House, Coral Gables, FL, 1963.
- Harmer, H., *Covered Bridges of Harrison County, West Virginia*, Educational Foundation, Charleston, WV, 1956.
- Harrington, L., and R. Harrington, *Covered Bridges of Central and Eastern Canada*, McGraw-Hill, Toronto, Canada, 1976.
- Harvey, M., *The Covered Bridges of Parke County, Indiana*, Wabash Valley Print Company, Montezuma, IN, 1963.
- Harvey, M., *The Covered Bridges of Indiana*, Wabash Valley Print Company, Montezuma, IN, 1963-1966.

Heisel, B., editor, *World Guide to Covered Bridges*, National Society for the Preservation of Covered Bridges, Marlboro, MA, 1989.

Hendricks, D., *Covered Bridges of WBYO Land*, Boyertown, PA, 1975.

Herrman, W., *Spans of Time—Covered Bridges of Delaware County*, NY, Delside Press, Delhi, NY, 1974.

Historic Highway Bridges In Pennsylvania, Pennsylvania Historical and Museum Commission, Harrisburg, PA, 1986.

Historic Highway Bridges of California, California Department of Transportation, Sacramento, CA, 1990.

Howard, A., *Covered Bridges of Bennington County*, Village Press, Unionville, VT, 1997.

Howard, A., *Covered Bridges of Connecticut*, Village Press, Unionville, CT, 1985.

Howard, A., *Covered Bridges of Massachusetts*, Village Press, Unionville, CT, 1978.

Howard, A., *Covered Bridges of Virginia*, Village Press, Unionville, CT, 1999.

Jakeman, A., *Old Covered Bridges of Maine*, Ocean Park, ME, 1980.

Jakeman, A., *Old Covered Bridges*, Stephen Dale Press, Brattleboro, VT, 1935.

Kenyon, T. and S. Snow, *New Hampshire's Covered Bridges*, Wake-Brook House, Sanbornville, NH, 1957.

Ketcham, B., *Covered Bridges on the Byways of Indiana*, Oxford Print Company, Oxford, OH, 1949.

Ketcham, B., *Covered Bridges on the Byways of Ohio*, Oxford Printing Company, Oxford, OH, 1969.

Krekeler, B., *Covered Bridges Today*, Daring Books, Canton, OH, 1989.

Lanks, H., *Covered Bridges*, Covered Bridge Heritage, Jenkintown, PA, 1968.

Marshall, R., *New Hampshire Covered Bridges—A Link With Our Past.*, TDS Printing, Nashua, NH, 1994.

McKee, B., *Historic American Covered Bridges*, ASCE Press, New York, NY, 1997.

Mead, E., *Through Covered Bridges to Concord—A Recollection of the Concord and Claremont Railroad (NH)*, Stephen Greene Press, Brattleboro, VT, 1970.

Miller, P., *Timbers of Time—The Existing Covered Bridges of Ulster County*, 1976, Erpf Cultural Center, Inc., Arkville, NY, 1977.

Missouri Mills and Covered Bridges, Missouri Tourism Commission, Jefferson City, MO, 1972.

Morely, S., *The Covered Bridges of California*, University of California Press, Berkeley, CA, 1938.

Morse, V., *Windham County's Famous Covered Bridges*, Book Cellar, Brattleboro, VT, 1960.

Nelson, J., *Spanning Time, Vermont's Covered Bridges*, New England Press, Shelburne, VT, 1997.

Nelson, L., *A Century of Oregon Covered Bridges 1851-1952*, Oregon Historical Society, Portland, OR, 1960.

Nelson, L., *The Colossus of 1812: An American Engineering Superlative*, ASCE Press, New York, NY, 1990.

Norman, J., *Oregon Covered Bridges—A Study for the 1989-1990 Legislature*, Oregon Highway Division, Salem, OR, 1988.

O'Grady, P., *Replicate: The Rebuilding of the Corbin Covered Bridge in Newport, New Hampshire*, Town & Country Reprographics, Inc., Concord, VT, 1998.

Pancoast, H. and C. Pancoast, *Covered Bridges to Yesterdays*, Newark, OH, 1959.

Petersen, H., *Kissing Bridges*, Stephen Greene Press, Brattleboro, VT, 1965.

Petersen, H., *The Covered Bridge*, Thomas Crowell Company, New York, NY, 1950.

Petersen, W., *Covered Bridges in Iowa*, The State Historical Society of Iowa, Iowa City, Iowa 1970.

Robertson, E. and D. Robertson, *Covered Bridges in the Saco River Valley*, Robertson Books, Westbrook, ME, 1993.

Sangster, T. and D. Sangstar, *Alabama's Covered Bridges*, Coffeetable Publications, Montgomery, AL, 1980.

Schlotterbeck, S., *Covered Bridges of Preble County, Ohio*, Preble County Historical Society, Eaton, OH, 1976.

Schneider, N., *Muskingum River Covered Bridges*, Southern Ohio Covered Bridge Association, Inc., Zanesville, OH, 1971.

Shank, W., *Historic Bridges of Pennsylvania*, Second edition, American Canal & Transportation Center, York, PA, 1974.

Shank, W., *The Amazing Pennsylvania Canals*, American Canal & Transportation Center, York, PA, 1975.

Sloane, E., *American Barns and Covered Bridges*, Funk, Inc., New York, NY, 1954.

Sloane, E., *Our Vanishing Landscape*, Funk, Inc., New York, NY, 1955.

Smith, E. and M. Horst, *Covered Bridges of Pennsylvania*, Dutchland, Applied Arts, Akron, PA, 1960.

Spargo, J., *Covered Wooden Bridges of Bennington County*, Bennington Historical Museum and Art Gallery, Bennington, VT, 1953.

Surany, A. and L. Fisher, *The Covered Bridge*, Holiday House, New York, NY, 1967.

Swanson, L., *Covered Bridges in Illinois, Iowa, and Wisconsin*, Moline, IL, 1970.

Templeton, N., *Vermont's Covered Bridges*, Third edition, First Vermont Bank, 1980.

Thomas, E.H., *Tracking the Crossings of the Yellow Breeches Creek, Cumberland County, PA*, Rea-Craft Press, Inc., Foxboro, MA, 1981.

Turnbull, M., *Some Delaware County Bridges*, Delaware County Historical Association, Delhi, NY, 1974.

Wagemann, C., *Covered Bridges of New England*, Tuttle, Rutland, VT, 1952.

Wagner, V., *Covered Bridges of Pennsylvania*, Commonwealth of Pennsylvania Department of Internal Affairs Bulletin, Harrisburg, PA, 1965.

Walker, E., *Covered Bridge Ramblings in New England*, Walker, Contocook, NH, 1959.

Way Back When—Informal Essays from Rush County Oral History, Indiana Junior Historical Society, Indianapolis, IN, 1981.

Webber, B. and M. Webber, *Oregon Covered Bridges, Expanded Edition*, Webb Research Group Publishers, Medford, OR, 1995.

- Weber, W., *The Covered Bridges in Indiana*, Northwood Institute, Midland, MI, 1977.
- Weber, W., *The Covered Bridges of Parke County, Indiana*, Indiana Covered Bridge Society, Inc., Indianapolis, IN, 1980.
- Wells, R., *Covered Bridges in America*, Rudge, New York, NY, 1931.
- Welt, S., *Covered Bridges of Oregon*, Mosaic Press, Cincinnati, OH, 1982.
- White, V., *Covered Bridges: Focus on Kentucky*, Kentucky Imprints, Berea, KY, 1985.
- Wiebel, J., *Life in the Slow Lane*, Reiman Publications, Greendale, WI, 1998.
- Wood, M., *The Covered Bridges of Ohio*, Old Trail Printing Company, Columbus, OH, 1993.
- Zacher, S., *The Covered Bridges of Pennsylvania*, Pennsylvania Historical and Museum Commission, 1982 and second edition, Harrisburg, PA, 1994.
- Ziegler, P., *Sentinels of Time—Vermont's Covered Bridges*, Down East Books, Camden, NJ 1983.
- Zweifel, K., *Covered Bridge Ghost Stories*, Al Crane Hill Publishers, Birmingham, AL, 1995.

Technical Information—Books / Articles Relevant to Covered Bridges

A Design Guide and Commentary—Wood Structures, ASCE Publishing, New York, NY, 1975.

American Wooden Bridges, ASCE History and Heritage Committee, ASCE Publishing, New York, NY, 1976.

Whipple, S., *An Elementary and Practical Treatise on Bridge Building*, D. Van Nostrand, New York, NY, 1899.

Benson, T., *Timberframe*, Taunton Press, Newtown, CT, 1999.

Breyer, D., K. Fridley, and K. Cobeen, *Design of Wood Structures*, McGraw-Hill, 1999.

Chapters include:

Cooper, T., "American Railroad Bridges," 1889

Edwards, L., "The Evolution of Early American Bridges," 1933

Fletcher, R. and J. Snow, "History of the Development of Wooden Bridges," 1932

Schneider, C. "Evolution of the Practice of American Bridge Building," 1905

Wilson, R., "Twenty Different Ways to Build a Covered Bridge," 1971

Davalos, J., M. Wolcott, B. Dickson, and J. Brokaw, *Quality Assurance and Inspection Manual for Timber Bridges*, Pennsylvania Department of Transportation, Harrisburg, PA, 1992.

DeLony, E., *Landmark American Bridges*, American Society of Civil Engineers Press, New York, NY, 1993.

Donnelly, C., *User Friendly Guide to Timber Bridges*, University of New Hampshire, 1996.

Edwards, L., *A Record of the History and Evolution of Early American Bridges*, University of Maine Press, Orono, ME, 1959.

Freas, A., *Evaluation, Maintenance and Upgrading of Wood Structures: A Guide and Commentary*, ASCE Publishing, New York, NY, 1982.

Goldstein, E., *Timber Construction for Architects and Builders*, McGraw-Hill, 1999.

Hartle, R., W. Amrhein, K. Wilson, D. Baughman, and J. Tkacs, *Bridge Inspector's Training Manual 90*, FHWA Report PD-91-015, Federal Highway Administration, Washington, DC, 1995.

Haupt, H., *General Theory of Bridge Construction*, D. Appleton & Company, New York, NY, 1851.

Haupt, H., *Hints on Bridge Construction by an Engineer*, 1841.

"Improvements to the Lattice Truss," *American Railroad Journal*, Vol.2, 1840.

James, J., "The Evolution of Wooden Bridge Trusses to 1850," *Journal of the Institute of Wood Science*, 1973.

Long, S., *Description of Col. Long's Bridges: Together with a Series of Directions to Bridge Builders*, J.F. Brown, Concord, NH, 1836.

Mackie, B., *Notches of All Kinds—A Book of Timber Joinery*, Firefly Books, Toronto, Canada, 1998.

Madsen, B., *Structural Behavior of Timber*, Timber Engineering, Ltd., North Vancouver, Canada, 1992.

National Design Specification for Wood Construction, American Forest and Paper Association, Washington, DC, 1997.

Peale, Charles W., *An Essay on Building Wooden Bridges*, printed by Francis Bailey, No. 116 High Street, Philadelphia, PA, 1797.

Ritter, M., *Timber Bridges—Design, Construction, Inspection, and Maintenance*, U.S. Department of Agriculture, U.S. Forest Service, Washington, DC, 1992.

Scofield, F. and W. O'Brien, *Modern Timber Engineering*, Southern Pine Association, New Orleans, LA, 1963.

Snow, J., *Wooden Bridge Construction on the Boston and Maine Railroad*, Boston Society of Civil Engineers, Boston, MA, 1895.

Timber Construction Manual, John Wiley & Sons, New York, NY, 1994.

Timber Frame Joinery & Design Workbook, Timber Framers' Guild of North America, 2000.

Town, I., *A Description of Ithiel Town's Improvements in the Construction of Wood and Iron Bridges*, South Converse, New Haven, CT, 1821.

Town, I., *A Description of Ithiel Town's Improvement in the Principle. Construction, and Practical Execution of Bridges, Roads, Railroads, and Aqueducts, Whether Built Entirely of Wood, or of Cast or Wrought Iron*, Hitchcock & Stafford, Printers, New Haven, CT, 1839.

Whipple, S., *A Work on Bridge Building*, H.H.Curtiss, Printer, Utica, NY, 1847.

Wood Handbook: Wood as an Engineering Material, U.S. Department of Agriculture, U.S. Forest Service, Washington, DC, 1987.

Wood, D., *Treatise on the Theory of the Construction of Bridges and Roofs*, J. Wiley & Sons, New York, NY, 1873.

Articles Related to Covered Bridges

Avent, R., "Structural Repair of Timber Using Epoxies," *Structure*, 2000: 39-45.

Austin, T., "Caring for a Covered Bridge," *ASCE Civil Engineering*, Vol. 6, 1991: 44-45.

Banasiak, D., "Covered Bridges Enjoy Revised Popularity in Buckeye State," *Roads & Bridges*, February, 1998: 80-82.

Barth, D., "America's Covered Bridges." *ASCE Civil Engineering*, Vol. 50, 1980: 51-54.

Black, T., "America's Covered Bridges: Spanning the Years." *American City & County*, Vol. 113, 1998: 32-42.

Bock, Eugene R., "The Covered Bridge of Indiana." *Indiana History Bulletin*, March, 1954: 56-63.

Brooks, K., "Assessment of the Environmental Effects Associated with Wooden Bridges Preserved with Creosote, Pentachlorophenol, or Chromated Copper Arsenate," Forest Products Laboratory 2000: FPL-RP-587.

Bruesch, L.D., "Forest Service Timber Bridge Specifications," *ASCE Journal of the Structural Division*, Vol. 108, 1982: 2737-2746.

Bruesch, L. and A. Pelzner, "Surfacing Treated Decks with Bituminous Materials," USDA Forest Service, 1976.

Brungraber, R., R. Gutkowski, W. Kindya, and R. McWilliams, "Timber Bridges: Part of the Solution for Rural America," *Transportation Research Record 1106*, 4th International Conference on Low Volume Roads, 1987.

Calil Jr., C., "Timber Bridges in South America," National Conference on Wood Transportation Structures, October 23-25, Madison, WI. General Technical Report FPL-GTR-94, U.S. Department of Agriculture, U.S. Forest Service, Madison, WI, 1996: 27-38.

"Comeback for Historic Covered Bridge." *Public Works* Vol. 131, 2000: 34-35.

Conwill, J.D., "The Covered Wooden Truss Bridge," *Classic Wood Structures*, ASCE Task Committee on Classic Wood Structures, 1989: 132-136.

"Covered Bridge Restoration through Artifact Research." *Public Works*, Vol. 120, 1989: 42-44.

Crosby, C., "What's So Special About a Covered Bridge?" *Keystone Folklore 23*, No. 3, 1979: 41- 52.

Delony, E., "Historic Bridges: Preservation Challenges." *Cultural Resources Management*, Vol. 14, 1991.

Dishongh, B., J. Smith, F. Castjohn, and J. Carnell, "Proof Loading Closed Timber Bridges," National Conference on Wood Transportation Structures, October 23-25, Madison, WI. General Technical Report FPL-GTR-94. U.S. Department of Agriculture, U.S. Forest Service, Madison, WI, 1996: 455-458.

Drafahl, J. and S. Drafahl, "Covering Covered Bridges." *Petersen's Photographic Magazine*, 18 September 1989: 30-33.

Duwadi, S. and M. Ritter, "Research on Timber Bridges and Related Topics," Research Update, Federal Highway Administration, Washington, D.C., 1995.

"Timber Bridges in the United States," *Public Roads*, 60(3): 32-40. 1997.

Duwadi, S., M. Ritter, and E. Cesa, "An Overview of the Wood in Transportation Programs in the United States," In: Natterer, J. and J.L. Snadoz, 5th World Conference on Timber Engineering August 17-20, Montreux, Switzerland. Swiss Federal Institute of Technology, Lausanne, Switzerland, Vol. 1, 1998: 32-39.

Emerson, R., D. Pollock, J. Kainz, K. Fridley, D. McLean, and R. Ross, "Nondestructive Evaluation Techniques for Timber Bridges," In: Natterer, J. and J.L. Snadoz, 5th World Conference on Timber Engineering, August 17-

20, Montreux, Switzerland. Swiss Federal Institute of Technology, Lausanne, Switzerland, Vol. 1, 1998: 670-677.

"Engineered Wood for Transportation Structures Workshop Record," Constructed Facilities Center, West Virginia University, Morgantown, WV, 1994.

Eslyn, W. and J. Clark, "Wood Bridges—Decay Inspection and Control," *Agricultural Handbook*, No. 557, October 1979.

Fortner, B., "Covered Bridge Correction," *ASCE Civil Engineering*, April 1999: A2-A5.

Fox, W., "An Inside Look at Pennsylvania's Covered Bridges," *Pennsylvania*, Vol. 23, No. 6, November/December 2000: 16-19.

Gasparini, D. and D. Simmons, "American Truss Bridge Connections in the 19th Century. I: 1829-1850," *Journal of Performance of Constructed Facilities*, Vol. 11, 1997: 119-129.

Griggs, Jr. F.E. and A.J. DeLuzio, "Stephen H. Long and Squire Whipple: The First American Structural Engineers," *ASCE Journal of Structural Engineering*, Vol. 121, 1995: 1352-1361.

Gutkowski, R.M. and W.J. McCutcheon, "Comparative Performance of Timber Bridges," *ASCE Journal of Structural Engineering*, Vol. 113, 1987: 1468-1486.

Hurlburt, B., "Basic Evaluation of the Structural Adequacy of Existing Timber Bridges," *Transportation Research Record*, Issue 647, 1977: 6-9.

Jackson, D., N. Shanahan, E. Sillin, and V. Marsh, "Saving Historic Bridges," *National Trust for Historic Preservation Information Sheet*, No. 36, 1984.

Jester, T., "Preserving Historic Bridges," *Cultural Resources Management*, Vol. 15, 1992.

Kemp, E.L., "The Artifact as Evidence: The Case for Covered Bridge Research and Restoration," *Proceedings, International Bridge Conference*, 1989: 335-339.

Kemp, E. and J. Hall, "Case Study of Burr Truss Covered Bridge," *ASCE Engineering Issues*, July 1975: 391-412.

Kleppe, O. and E. Aasheim, "Timber Bridges in Nordic Countries," National Conference on Wood Transportation Structures, October 23-25, Madison, WI. General Technical Report FPL-GTR-94, U.S. Department of Agriculture, U.S. Forest Service, Madison, WI, 1996: 10-16.

Lewandoski, J., "Wood Truss Highway Bridges in North America: Repair & Strengthening," *Proceedings of the Fifth International Conference on Structural Faults and Repairs: Extending the Life of Bridges*, Vol. 1, 1993: 217-223.

"Long-Range Study of Vermont's Town-Owned Covered Bridges," 11th Annual International Bridge Conference, Pittsburgh, PA, 1994.

Marathon, N., "Rural Bridges: An Assessment Based Upon the National Bridge Inventory," *Transportation Report*, Office of Transportation, USDA, Washington, DC, August, 1989.

May, M., "DOT Helps Preserve Ohio's History," *Public Works*, Vol. 127, 1996: 33-35.

McLain, T., L. Soltis, D. Pollock, Jr., and T. Wilkinson, "LRFD for Engineered Wood Structures - Connection Behavioral Equations," *ASCE Journal of Structural Engineering*, Vol. 119, 1993: 3024-3038.

McCutcheon, W. J., R.M. Gutkowski, and R.C. Moody, "Performance and Rehabilitation of Timber Bridges," *Transportation Research Record 1053*, 1986: 65-69.

Meierhoefer, U.A., "Timber Bridges in Central Europe, Yesterday, Today, Tomorrow." National Conference on Wood Transportation Structures, October 23-25, Madison, WI. General Technical Report FPL-GTR-94, U.S. Department of Agriculture, U.S. Forest Service, Madison, WI, 1996: 22-26.

Moody, R.C. and M.A. Ritter, "Wood In Infrastructure: Analysis of Research Needs and Goals," *Wood Engineering in the 21st Century: Research Needs and Goals*, ASCE, Portland, OR, 1997: 96-108.

Muchmore, F.W., "Techniques to Bring New Life to Timber Bridges," *ASCE Journal of Structural Engineering*, Vol. 110, 1984: 1832-1846.

Nowak, A., C. Eamon, and M. Ritter, "Structural Reliability of Plank Decks," Proceedings of the 1999 Structures Congress, Structural Engineering in the 21st Century April, 18-21, 1999: 688-691.

Nowak, A. and M. Ritter, "Load and Resistance Factor Design Code for Wood Bridges." Proceedings of 4th International Bridge Engineering Conference; August 28-30, 1995 Vol. 2, 1995: 351-357.

Oliva, M., R. Tuomi, and A. Dimakis, "New Ideas for Timber Bridges," *Transportation Research Record 1053*, 1986: 59-64.

Pellerin, R., R. Ross, R. Falk, and N. Volny, "Evaluation of Timber Bridges Using Stress Wave Technology," *Pacific Timber Engineering Conference*, July 11-15, 1994.

Pellerin, R., J. Lavinder, R. Ross, R. Falk, and N. Volny, "In-place Detection of Decay in Timber Bridges - An Application of Stress Wave Technology," National Conference on Wood Transportation Structures, October 23-25, Madison, WI. General Technical Report FPL-GTR-94, U.S. Department of Agriculture, U.S. Forest Service, Madison, WI, 1996: 10-16.

Pierce, P., "Covered Bridges—Life-Cycle Cost Advantages?" ASCE Structures Congress XV , 1997.

Rammer, D., "Experimental Shear Strength of Glued-Laminated Beams." FPL-RP-527, Forest Products Laboratory, 1994.

Rammer, D., R. Soltis, and P. Lebow, "Experimental Shear Strength of Unchecked Solid-Sawn Douglas Fir," FPL-RP-553, Forest Products Laboratory, 1996.

Ritter, M., "Current Timber Bridge Research and Development in the United States," Forest Products Laboratory, January 20, 1993.

Ritter, M., "Emerging Timber Bridge Technology in the United States." Elsevier Science Ltd. T134-1, 1998: 1-8.

Ritter, M. and S. Duwadi, "Research Accomplishments for Wood Transportation Structures Based on a National Research Needs Assessment," General Technical Report FPL-GTR-105. U.S. Department of Agriculture, U.S. Forest Service, Madison, WI, 1998.

Ritter, M., S. Duwadi, and P. Lee, Eds. 1996. "National Conference on Wood Transportation Structures, October 23-25, Madison, WI." General Technical Report FPL-GTR-94, U.S. Department of Agriculture, U.S. Forest Service, Madison, WI, 1996.

Ritter, M., S. Duwadi, and R. Moody, "Development of a Six-Year Research Needs Assessment for Timber Transportation Structures," Forest Products Laboratory, 1993.

Ritter, M., R. Moody, and S. Duwadi, "Summary of U.S. Research on Wood Transportation Structures." Proceedings of the International Wood Engineering Conference, October 28-31, New Orleans, LA, Vol. 1, 1996: 81-88.

Ritter, M. and A. Nowak, "LRFD Provisions for Wood Bridges." Structures Congress 12. Proceedings of Structures Congress April 24-28, 1994, Atlanta GA, Vol. 1, 1994: 549-554.

- Ritter, M., T. Wipf, and D. Wood, "Evaluation and Testing of Timber Railroad Bridges." In: Natterer, J.; Snadoz, J.L. 5th World Conference on Timber Engineering, August 17-20, Montreux, Switzerland. Swiss Federal Institute of Technology, Lausanne, Switzerland. Vol. 1, 1998: 670-677.
- Ritter, M. and K. Stanfill-McMillan, "Wood Bridges in New England," *Structures Congress 13*, Proceedings of Structures Congress April 2-5, 1995, Boston, MA, Vol. 1, 1995: 1081-1084.
- Ritter, M. and T. Williamson, "Maintenance Practices for Wood Bridges," Structures Congress 13. Proceedings of Structures Congress April 2-5, 1995, Boston MA, Vol. 1, 1995: 290-293.
- Rogers, H., "Old Blenheim Covered Bridge," *Classic Wood Structures*, ASCE Task Committee Classic Wood Structures, 1989: 132-136.
- Rogers, H., "Reinforcing Historic Covered Bridges." *Proceedings*, International Bridge Conference, 1987: 87-90.
- Rogers, H., "Reinforcing Historic Covered Bridges," *Public Works*, Vol. 119, 1988: 63-65.
- Rogers, H. and Montgomery, D., "Historic Bridge Replicated," *Public Works*, Vol. 123, 1992: 30-33.
- Ross, R., R. Pellerin, N. Volny, W. Salsig, and R. Falk, "Inspection of Timber Bridges Using Stress Wave Timing Nondestructive Evaluation Tools—A Guide for Use and Interpretation, General Technical Report, FPL-GTR-114, U.S. Forest Service, 1999: 1-15.
- Ross, R. and R. Pellerin, "Nondestructive Testing for Assessing Wood Members In Structures—A Review," FPL-GTR-70, U.S. Forest Service, 1994.
- Seligman, J., "Reconstruction of a Covered Bridge: Spanning Time." *Public Works*, Vol. 130, 1999: 60-61.
- Smith, K. and J. Andrews, "Restoration of Meem's Bottom Covered Bridge." *Transportation Research Record Issue 834*, 1981: 6-11.
- Smollen, J., "Rehabilitating the Covered Bridges of Ashtabula County," Proceedings of the First Historic Bridges Conference, Ohio Historical Society. Columbus, OH, 1985.
- Sherman, J., "Last of the Covered Bridge Builders." *Historic Preservation*, Vol. 38, No. 4, 1986: 20-22.
- Stanfill-McMillan, K. and J. Kainz, "Factors Influencing Timber Bridge Performance." *Structures Congress 13*. Proceedings of Structures Congress April 2-5, 1995, Boston, MA, Vol. 1, 1995.
- "Study In Wood." *Bridge Design and Engineering*, May 1997: 68-69.
- "Swiss Will Rebuild an Historic Covered Bridge." *Engineering News Record*, Vol. 231, 1993: 18.
- Thomas, W. and J. Puckett, "Analysis, Design, Rating, and Drafting of Wood Bridge Superstructures." National Conference on Wood Transportation Structures, October 23-25, Madison, WI. General Technical Report FPL-GTR-94, U.S. Department of Agriculture, U.S. Forest Service, Madison, WI, 1996: 361-370.
- Thompson, S., "Bridge to the Past." *American City and Country*, Vol. 106, 1991: 62-69.
- "Those Intriguing Town Lattice Timber Trusses." *ASCE Practice Periodical on Structural Design and Construction*, Vol. 6, 2001: 92-94.
- "Timber Bridge Decks." *ASCE Civil Engineering*, Vol. 55, 1985: 47-49.
- "Timber Highway Bridge Construction Practices in the United States." National Conference on Wood Transportation Structures, October 23-25, Madison, WI. General Technical Report FPL-GTR-94, U.S. Department of Agriculture, U.S. Forest Service, Madison, WI, 1996: 1-9.

Verna, J., J. Graham, J. Shannon, and P. Sanders, "Timber Bridges: Benefits and Costs." *ASCE Journal of the Structural Division*, Vol. 110, 1984: 1563-1571.

"Vermont's Covered Bridge Study—The Rest of the Story," 14th Annual International Bridge Conference, Pittsburgh, PA, 1997.

Wacker, J., S. Catherman, and R. Winnett, "Field Performance of Timber Bridges—12. Christian Hollow Stress-Laminated Box-Beam Bridge," FPL-RP-560, Forest Products Laboratory, 1998.

Walter, G., "Timber Bridges in Australia," National Conference on Wood Transportation Structures, October 23-25, Madison, WI. General Technical Report FPL-GTR-94. U.S. Department of Agriculture, U.S. Forest Service, Madison, WI, 1996: 17-21.

Williamson, T., "Bibliography of Timber Highway Bridge Design." *ASCE Journal of the Structural Division*, Vol. 101, 1975: 1-10.

Wipf, T., M. Ritter, and D. Wood, "Dynamic Evaluation and Testing of Timber Highway Bridges," Proceedings of the Pacific Timber Engineering Conference, March 14-18, Rotorua, New Zealand. New Zealand Forest Research Institute, Forest Research Bulletin No. 212. Vol. 3, 1999: 333-340.

Covered Bridge Societies

In addition to sources such as State historic preservation offices and the structures unit within a State transportation agency, the most likely sources of additional information are covered bridge societies. A number of societies, including national, statewide, and regional organizations, are devoted to the preservation of covered bridges. There are also organizations devoted to a single covered bridge. Most societies publish periodic newsletters; some also produce supplemental documents. Many societies have access to a wealth of information about the history of individual bridges, but few have specific information that would be helpful to an engineer or builder. Nonetheless, one might benefit by contacting such organizations when doing research about a particular bridge.

The larger and more active organizations in the United States, presented alphabetically by State, include:

National Society for the Preservation of Covered Bridges

c/o David Topham, Treasurer, 1021 Cellana Court, Fort Myers, FL 33908 (May to October), 50 Samoset Village Way, Rockport, ME 04856-9501

Indiana Covered Bridge Society

c/o John Sechrist, Treasurer, 725 Sanders Street, Indianapolis, IN 46203

New York State Covered Bridge Society

c/o Henry Messing, Treasurer, 958 Grove Street, Elmira, NY 14901

Ohio Historic Bridge Association Inc.

c/o Miriam Wood, 3155 Whitehead Road, Columbus, OH 43204-1855

Northern Ohio Covered Bridge Society

c/o Pat Eierman, 6622 Balsam Drive, Bedford Heights, OH 44146

Covered Bridge Society of Oregon

c/o Bill Cockrell, 3940 Courtney Lane, South East, Salem, OR 97302

Theodore Burr Covered Bridge Society (Pennsylvania)

P.O. Box 2383, Lancaster, PA 17603-2383 or,

c/o Russel J. Holmes, Treasurer, Box 95, Seven-Valleys, PA 17360-0095, or

Thomas E. Walczak, President, 3012 Old Pittsburgh Road, New Castle, PA 16101-6085

Vermont Covered Bridge Society

P.O. Box 97, Jeffersonville, VT 05464-0097

These societies are not permanent, and contact information changes periodically. The above list was current at the time of this manual's publishing.

