

BIOLOGICAL REPORT 82(10.109)
AUGUST 1985

HABITAT SUITABILITY INDEX MODELS AND INSTREAM FLOW SUITABILITY CURVES: PINK SALMON

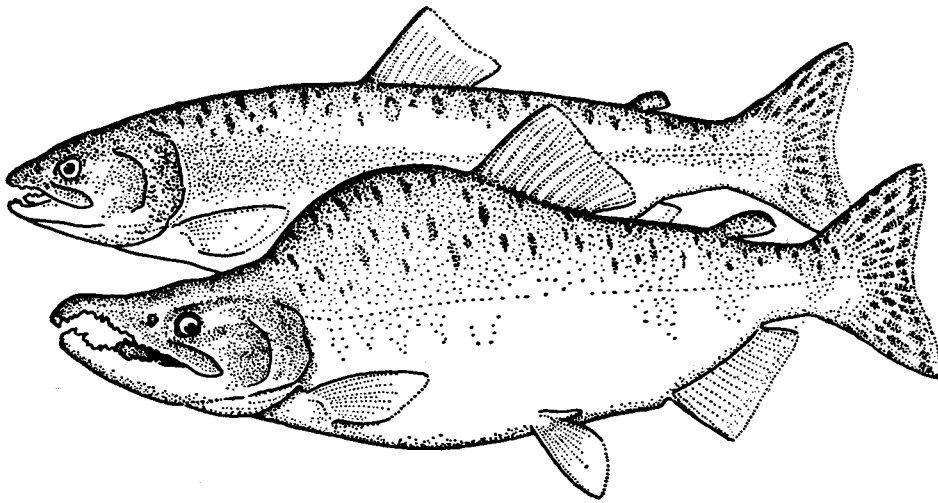

Fish and Wildlife Service

. Department of the Interior

SK
361
.U54
no. 82-
10.109

Biological Report 82(10.109)
August 1985

HABITAT SUITABILITY INDEX MODELS AND INSTREAM FLOW SUITABILITY
CURVES: PINK SALMON

by

Robert F. Raleigh
P.O. Box 625
Council, ID 83612

and

Patrick C. Nelson
Instream Flow and Aquatic Systems Group
Western Energy and Land Use Team
U.S. Fish and Wildlife Service
Drake Creekside Building One
2627 Redwing Road
Fort Collins, CO 80526-2899

Western Energy and Land Use Team
Division of Biological Services
Research and Development
Fish and Wildlife Service
U.S. Department of the Interior
Washington, DC 20240

This report should be cited as:

Raleigh, R. F., and P. C. Nelson. 1985. Habitat suitability index models and instream flow suitability curves: Pink salmon. U.S. Fish Wildl. Serv. Biol. Rep. 82(10.109). 36 pp.

PREFACE

Information presented in this document is for use with the Habitat Evaluation Procedures (HEP) and the Instream Flow Incremental Methodology (IFIM). The information also should be useful for impact assessment and for developing management recommendations and mitigation alternatives for the species using methodologies other than HEP or IFIM. The comparison and recommendations for use of HEP and IFIM presented by Armour et al. (1984)¹ should help potential users of these two methodologies determine the most efficient way to utilize the information in this publication.

The Suitability Index (SI) curves and graphs and Habitat Suitability Index (HSI) models presented in this report are based primarily on a synthesis of information obtained from a review of the literature concerning the habitat requirements of the species. The HSI models and SI curves are scaled to produce an index between 0 (unsuitable habitat) and 1 (optimal habitat). Assumptions used to transform habitat use information into an index are noted, and guidelines for application of the curves and models are described. A discussion of IFIM and pink salmon SI curves available for use with IFIM is included.

The SI curves and HSI models are starting points for users of HEP or IFIM to develop their own curves and models. Use of the SI curves and HSI models within project-specific applicational constraints is likely to require modification of the SI curves or graphs and HSI models to meet those constraints and to be applicable to local habitat conditions. Users of the SI graphs and/or HSI models with HEP should be familiar with the standards for developing HSI models (U.S. Fish and Wildlife Service 1981)¹ and the guidelines for simplifying HSI models and recommended measurement techniques for model variables (Terrell et al. 1982; Hamilton and Bergersen 1984).¹ Users of the SI curves with IFIM should be familiar with the Guide to Stream Habitat Analysis (Bovee 1982)¹ and the User's Guide to the Physical Habitat Simulation System (Milhous et al. 1984).¹ Material for use with IFIM is presented in English units of measure because flow-related data are normally collected in English units.

The HSI models and SI curves are hypotheses of species-habitat relationships, not statements of proven cause and effect relationships. The curves and models are based on the literature and professional judgment. They have not been applied in the field. For this reason, the U.S. Fish and Wildlife

¹Citation included in References.

Service encourages model users to convey comments and suggestions that may help us increase the utility and effectiveness of this habitat-based approach to fisheries planning. Please send comments to:

Habitat Evaluation Procedures Group

or

Instream Flow and Aquatic Systems Group

Western Energy and Land Use Team

U.S. Fish and Wildlife Service

2627 Redwing Road

Fort Collins, CO 80526-2899

CONTENTS

	<u>Page</u>
PREFACE	iii
ACKNOWLEDGMENTS	vi
HABITAT USE INFORMATION	1
General	1
Distribution and Life Cycle	2
Specific Habitat Requirements	4
Adult Stage	4
Embryos and Yok Sac Fry (the Intergravel Habitat)	6
Emergent Fry Stage (Seward Migrant)	8
HABITAT SUITABILITY INDEX (HSI) MODELS	8
HSI Model Applicability	8
Model Description	9
Suitability Index (SI) Graphs for Model Variables	10
Model 1, Limiting Factor	17
Model 2, Compensatory Limiting Factor	17
Interpreting Model Outputs	17
INSTREAM FLOW INCREMENTAL METHODOLOGY (IFIM)	19
Suitability Index Graphs as Used in IFIM	19
Availability of Graphs for Use in IFIM	20
REFERENCES	33

ACKNOWLEDGMENTS

We gratefully acknowledge Dr. William J. McNeil, Oregon Aqua-Foods, Inc. and Jack E. Bailey for their review and suggestions for improvement of the manuscript. However, the reader should not construe this as an endorsement of the model contents. Charles Solomon reviewed the model, managed the contract, and prepared the final manuscript for publication. Word processing was provided by Elizabeth Graf, Carolyn Gulzow and Dora Ibarra. Editing was conducted by Tricia Rosenthal and Paul Eschmeyer. The cover is from Freshwater Fishes of Canada, Bulletin 184, Fisheries Research Board of Canada, by W. B. Scott and E. J. Crossman.

PINK SALMON (Oncorhynchus gorbuscha)

HABITAT USE INFORMATION

General

The information included in this pink salmon model is restricted to the fresh and brackish water habitats occupied by the spawning adults, developing embryos, and seaward migrating fry. The ocean habitat requirements of pink salmon are not included. Pink salmon adults and seaward migrating fry spend very little time in freshwater, and the entire juvenile stage is in seawater, thus the HSI model concentrates on the requirements of the developing embryos and yolk sac fry.

The HSI model was constructed by searching the available technical literature, agency data files, and individual study progress reports for information on the habitat requirements of pink salmon. These data are compiled and Suitability Index (SI) graphs are constructed for each habitat variable identified from the information base. All habitat variables that were identified are included, to enable the user to evaluate a wide variety of habitat conditions useful in managing or improving pink salmon habitat, or in assessing project impacts. The HSI model is flexible enough to enable use of one to all of the available variables to suit the needs of the user.

The SI graphs for the HSI model are constructed by quantifying field and laboratory studies information on the effect of each habitat variable such as temperature, dissolved oxygen, spawning gravel size, and siltation on the growth, survival, or biomass of the species by life stage. The graphs are developed on the assumption that increments of growth, survival, or biomass plotted on the y-axis can be directly converted into an index of suitability from 0.0 to 1.0 for the species (0.0 indicating unsuitable conditions and 1.0 optimal conditions). Measurements of each habitat variable taken at the proper time in the field can be applied to the SI graphs to obtain an estimate of the suitability of the variable in meeting the habitat requirements of the species by life stage. SI values for each variable are used in the model to assist in the decision-making process.

Instream Flow SI graphs (preference curves) are based on field observations of the frequency with which certain values within a range of values for a habitat variable such as gravel size are used by individuals of a species.

The premise is that individuals of the species will select and occupy the best habitat conditions available to them. Optimal conditions for a variable are considered to be those under which most individuals are observed. Range limits for a variable are the conditions under which the fewest are observed. The IFIM utilizes five SI graphs: flow velocity, depth, substrate composition, temperature, and cover. Wherever individuals of species are observed in the stream, measurements are taken on the above five variables. Each variable is assumed to be independent of the other four, both in the model probability theory equations and in collecting information for constructing the SI graphs. It is also assumed that a full range of variable values were available for selection by individuals of the species at each study stream and SI graph data collection site. Otherwise, bias will occur in the frequency analysis method.

Information for SI graph construction gleaned from field and laboratory study results have limitations. It is sometimes difficult to determine if the full range of usable values for the variable have been included in field studies. For example, the species may have been observed using spawning gravel ranging from 0.3 to 10 cm in size. Studies of the effects of siltation on embryo survival for the species may indicate that the lower limit of 0.3 cm appears acceptable. However, if additional or different streams had been included in the studies, the upper gravel size limit may have exceeded 10 cm.

Laboratory tests utilized in constructing the HSI model SI graphs can often add more certainty to upper, lower and optimal range values, especially for variables such as temperature, dissolved oxygen, and pH. However, both laboratory and field study results must be considered in light of test conditions, eg. acclimation conditions, handling, exposure times, control test results for laboratory tests, and observation and data collection procedures and conditions for field studies. For these reasons some judgment is often necessary in constructing SI graphs for both IFG and HSI models and some variability probably exists in the shape of the SI graphs. The data base and SI graphs are reviewed by biologists from different agencies familiar with the ecology of the species and documentation, suggested changes not at variance with published study results are incorporated. However, the user is advised to review each SI graph to see how well it represents known regional requirements for the species. Changes should be made if indicated, but the reasons for each change should be fully documented. The pink salmon model was written by Robert F. Raleigh. Patrick C. Nelson wrote the IFG section.

Distribution and Life Cycle

Pink salmon spawn in rivers as far south as Puget Sound and northward through Canada and most of Alaska. Their centers of abundance are southeastern Alaska, Prince William Sound, Cook Inlet, and Kodiak Island, but they are common from the Fraser River in Canada to Kotzebue Sound in Alaska. Scattered populations extend northward above the Seward Peninsula into the Arctic Ocean (Atkinson et al. 1966). Pink salmon are also common along the Kamchatka Peninsula in Russia, and small populations occur in Korea, the Kurile Islands, and southward to the Yurappu River at Hokkaido, Japan (Ishido 1967).

Pink salmon have been introduced into the Great Lakes and into rivers along the north coast of Russia. Most attempts to extend the range of pink salmon have met with little success except on the Kola Peninsula in northern Russia (Ishida 1967).

Pink salmon are the smallest of the five species of Pacific salmon that inhabit rivers along the Pacific Coast of North America. They mature at two years of age at about 34 to 63 cm fork length and about 1.4 to 3.6 kg in weight (average 1.8 kg) (Kaganovskii 1949; Neave 1963).

All five species of North American Pacific salmon home to natal streams to spawn and, with rare exceptions, die after spawning. Pink salmon are included in the above generalization, but are believed to be more likely to stray during the spawning migration than coho salmon (*O. kisutch*), chinook salmon (*O. tshawytscha*), or sockeye salmon (*O. nerka*).

Pink salmon enter the natal rivers to spawn in mid to late summer. Changes in volume of flow and water temperatures within the normal stream seasonal ranges do not appear to be significant factors in triggering stream entry (Davidson et al. 1943; Sheridan 1962). The embryos overwinter in the gravel; yolk sac fry emerge from the gravel in early spring and migrate immediately to the ocean (Divinin 1959; Sheridan 1962; Ishida 1967). On the average, pink salmon spend about 6-9 months in freshwater and 15-18 months in the ocean. Although it has been said that pink salmon are dependent on the freshwater environment for only a short time and are completely independent of it for food, this statement is not entirely true. Adult pink salmon stop feeding when they enter freshwater to spawn but Divinin (1959) found that about 24% of the seaward migrating pink salmon fry that he examined began feeding before they entered saltwater. Fry with food in their stomachs tended to have $\leq 1\%$ of the yolk sac remaining. The food items included chironomid larvae, Plecoptera, Ephemeroptera, Harpacticoida, Ostracoda, and larval fishes (Divinin 1959).

Adult pink salmon tend to spawn in the lower reaches of coastal rivers including the brackish, intertidal, outwash gravels at the mouth (Bailey 1966; McNeil 1966), but may travel upstream for 200 to 300 miles to spawn in large, unobstructed rivers (Neave 1963). Spawning may peak as early as mid-July (Ishida 1966) or as late as October (Sheridan 1962). The timing of spawning tends to be earlier in southern areas of the range (Ishida 1966). Within a single population, spawning usually takes place within a well defined two to three week period (Sheridan 1962). Bailey (pers. comm. 1985) and McNeil (1968) recommend that spawning densities do not exceed one pair of adults per square yard of suitable spawning habitat.

Fecundity of pink salmon ranges from about 800 to 2300 eggs per female depending on size (Semko 1939; Neave 1966). In uncompacted gravel, the demersal eggs are deposited about 15 to 25 cm deep (range 7.0 to 45 cm) in two to four pockets composing a redd excavated in the gravel by the female (Divinin 1959). After deposition, the eggs are covered with gravel displaced upstream. Because of the invariable two year life cycle of pink salmon, odd and even year spawning populations are effectively isolated from each other genetically (Neave 1952, 1953; Ricker 1962).

Specific Habitat Requirements, Sources, and Assumptions

The annual flow regime and the quality of salmonid riverine habitat are closely related. The critical period for pink salmon is the time between egg deposition in late summer and fall and fry emergence in the following spring. Although flows must be adequate to meet the needs of the developing embryos and yolk sac fry in the gravel, abnormally low or high flows appear to be destructive. Significant mortalities to pink salmon embryos and yolk sac fry have been reported due to freezing of redds caused by insufficient flow in winter, and from redd destruction caused by gravel movement during abnormally high flows during freshets (Sheridan and McNeil 1960; Andrew and Geen 1960). An annual base flow $\geq 50\%$ of the average annual daily flow is considered excellent for salmonid production, a base flow of 25 to 50% is considered fair to good and one of $< 25\%$ is considered poor (adapted from Tennent 1976; Binns and Eiserman 1979; Wesche 1980). Nehring and Anderson (1982, 1983) consider a peak flow of two to five times the magnitude of an excellent base flow, or ≤ 2 times the average annual daily flow (Lister and Walker 1966) to be acceptable for good salmonid production, but peak flows above these limits are considered progressively more destructive. Peak and base flow volumes that are controlled in salmon and trout habitats in dam tailwaters can enhance production of juvenile chum, coho, and chinook salmon (Lister and Walker 1966) and trout (Nehring and Anderson 1982, 1983), or give a competitive edge to spring or fall spawning stocks, depending on timing and amplitude of flow releases.

The potential of the river to produce fish food does not appear to be a significant habitat requirement factor for pink salmon for several reasons: the fish typically do not feed as spawning adults after entering freshwater; tend to spawn near the ocean; migrate to the ocean as yolk sac fry immediately after emergence; reach the ocean within a short time period; and have from 5-10% of the yolk sac remaining at time of migration. Also, pink salmon do not appear to be significantly dependent on fresh water as a rearing habitat, thus it would appear that the more high quality spawning area per unit of river, the higher the freshwater production potential should be.

Adult Stage

Spawning pink salmon appear to have a wide tolerance for variations in temperature, dissolved oxygen, and salinity. Spawning adults at moderate to light densities do not appear to select spawning sites with values for variables outside the tolerance ranges of the embryos; at high population densities, they have been observed spawning at temperatures ranging from 5 to 19°C (Semko 1939; Divinin 1952), at dissolved oxygen concentrations of 40 to 120% saturation (Divinin 1952), and at salinities ranging from fresh-water to 28 ppt (Bailey 1966; McNeil 1966). However, the tolerances of developing embryos for these variables appear to be more restricted. Consequently, results of studies on adults are used here to establish range limits for variables, but more reliance is placed on results of studies of embryos and yolk sac fry to establish optimal values for SI graph construction.

The major function of the gravel cover over salmonid embryos is to protect them from predation, mechanical injury, and ultraviolet light. Neave (1966) found that spawning areas intensively used by pink salmon tended to have relatively low gradient combined with beds of relatively small gravel. Semko (1939) observed that pink salmon spawned on "medium sized gravel" Andrew and Geen (1960) reported that about 80% of the gravel obtained in samples from areas of heavy spawning by sockeye and pink salmon in several major salmon streams in Canada ranged from 0.3 to 10 cm in diameter. Chambers (1956), after studying the characteristics of spawning redds of several species of Pacific salmon, stated that gravel must be of a size that can be moved by the fish and the current when the redd is built. Therefore, the size of the fish determines how large the spawning gravel can be. Although gravel of 1 to 5 cm was the most common size in all salmon redds studied, sockeye salmon, the smallest species studied by Chambers (1956) appeared to prefer gravel ≤ 5 cm. The sizes of pink salmon average slightly smaller than sockeye. From the above information it is concluded that pink salmon normally select spawning gravel within the range of 0.3 - 10 cm with an optimal size of 1 to ≤ 5 cm.

Water velocity and minimal depths appear to influence the selection of spawning site and survival of embryos. Velocity appears to be the major factor and minimal depth a secondary factor. Spawning of pink salmon in productive streams occurs at depths of ≤ 0.2 m to ≥ 7 m (Divinin 1952; Chambers 1956). Sockeye salmon have been reported spawning in lakes at depths > 21 m (Canadian Department of Fisheries 1959). Andrew and Geen (1960) report that a three year study on the Chilko River indicated that beyond a minimal figure, depth did not appear to exert a major influence on the selection of spawning sites, but velocity did. Gravel beds that are dewatered and exposed to freezing in winter were never heavily populated, nor were they the first choice of spawning salmon. Divinin (1952) observed that when the distribution of pink salmon spawners over the spawning grounds was optimum, there was no spawning in waters shallower than 0.2 m. However, W. J. McNeil (personal communication 1985) reported successful spawning at shallower depths. When densities of spawners are high, however, pink salmon have been reported to spawn on sand and silt substrates (Semko 1939) and at depths of ≤ 0.1 m (Divinin 1952). It seems likely that embryo mortalities would be excessive under these extreme conditions. It is further concluded that spawning of pink salmon can successfully occur over a wide range of depths and that depth alone, greater than the minimum required to protect the embryos from drying or freezing, does not significantly affect the selection of spawning sites or the survival of embryos.

An acceptable minimal spawning depth depends on the amount of flow fluctuation, but in rivers with relatively stable flows during the incubation period (base flow $\geq 50\%$ of the average annual daily flows, and high flows ≤ 2 times that average), the minimal safe spawning depth for pink salmon could be expected to be ≥ 15 cm.

Krokhin and Krogus (1937) listed spawning velocities of 30 to 60 cm/sec for pink salmon (as reported in Ishida 1966). Divinin (1952) reported typical spawning velocities of 40 to 80 cm/sec for pink salmon. Andrew and Geen (1960) reported average velocities of 33 to 85 cm/sec, but the greatest densities of spawners occurred near the upper range of velocities in areas

with an average velocity of 67 cm/sec. Multiple regression analysis of Chilko river data indicated that the greatest spawner density was significantly correlated with velocities of 42.7 cm/sec when measured at 10 cm above the bottom (Andrew and Geen 1960). In light of these data, a usable spawning velocity range for pink salmon of 30 to 90 cm/sec was selected with an optimal range of 40 to 70 cm/sec.

The pH in rivers typically occupied by pink salmon is 6.8 to 8.0 (Ishida 1966); the tolerance range of the species is assumed to be similar to that of other salmonids, 5.5 to 9.0 (Behnke and Zarn 1976).

Spawning has been observed at temperatures of 5 to 14°C (Semko 1939) and 7 to 19°C (Divinin 1952). Average spawning temperatures reported ranged from 9.2 to 13.7°C (Kuznetsov 1928; Semko 1939).

Embryos and Yolk Sac Fry (the Intergravel Habitat)

The eggs usually remain in substrate gravels of the stream through late summer and winter months. Hatching from the egg can begin as early as late September in some streams and as late as mid-January in others dependent upon time of spawning and average stream temperatures. The egg stage averages 63 to 110 days from time of fertilization. The intergravel yolk sac fry stage from hatching until emergence averages an additional 80 to 120 days (Kuznetsov 1928). At emergence, the yolk sac fry must move upward through the gravel to the stream.

Wickett (1962) and McNeil (1966) found that high survival of pink salmon fry was correlated with high gravel permeability. Beds of slightly larger gravel and redds with $\leq 5\%$ fines had the best permeability and survival rates for embryos and emergent fry. Survival of embryos and intergravel, yolk sac fry was low as fines approached and exceeded 15%. These data are compatible with the gravel size range and optimal values shown above for spawning pink salmon adults. It seems safe to conclude that optimal habitat conditions in the redd occur with $\leq 5\%$ fines and become increasingly marginal as that percentage approaches or exceeds 15%.

Pink salmon may spawn in slightly faster currents than preferred by other salmonids, and the eggs may require more dissolved oxygen, because pink salmon embryos contain less carotinoid pigment (Nikolskii and Soin 1954; Ishida 1966). McNeil (1966) found intergravel oxygen levels in pink salmon redds to be at 64% of saturation (7 mg/l) or higher in Sashin Creek, Alaska. No studies of the effects of low dissolved oxygen on pink salmon embryos and fry have been reported. It is assumed that the effects would be similar to those found in studies of other salmonid species, e.g. that low O_2 levels (≤ 3 mg/l) result in developmental deformities, decreased growth, and increased mortality (Doudoroff and Shumway 1970). It is further concluded that an optimal O_2 level is ≥ 8 mg/l at stream temperatures of $\leq 10^\circ\text{C}$.

Sheridan (1962) stated that unusually high or low incubation temperatures could cause hatching and emergent times inappropriate to the best survival of pink salmon. Petrenko (1964) found that pink salmon yolk sac fry had wide temperature tolerance and could withstand wide fluctuations in temperature if

the embryos were incubated at $\geq 5^{\circ}\text{C}$ during the early developmental stages. However, embryos incubated early at $> 10.5^{\circ}\text{C}$ suffered a higher rate of mortality and deformities, and grew more slowly. Bailey (J. E. Bailey, Natural Marine Fisheries Service, Juneau, Alaska; letter dated May 11, 1985) reported $< 2\%$ survival of pink salmon embryos incubated at $< 5^{\circ}\text{C}$ and 100% mortality at temperatures $> 16^{\circ}\text{C}$ during the first three weeks after fertilization. McNeil (1968) suggests that pink salmon eggs that begin incubation at temperatures $> 8^{\circ}\text{C}$ survive better than those that begin incubation at $< 8^{\circ}\text{C}$ temperatures. Bell (1973) and Bailey and Evans (1971) list normal spawning temperatures in the range of 7.2 to 12.8 $^{\circ}\text{C}$. Spawning has been observed at temperatures ranging from 5 to 19 $^{\circ}\text{C}$ (Semko 1939; Divinin 1952). Based on this data, an overall early embryo development range of 5 to 16 $^{\circ}\text{C}$ with an optimal range of 8 to 10.5 $^{\circ}\text{C}$ was selected.

Pink salmon spawn in the intertidal zone of spawning streams. These intertidal areas tend to have greater and more rapid temperature fluctuations, $\geq 5^{\circ}\text{C}/\text{hr}$ (Helle et al. 1964); gravel of a smaller average size; more fines; higher salinities; and progressively longer exposure times to salinity in a gradient downstream toward the sea. All of these factors tend to increase embryo mortality in downstream areas. As tidewater moves upstream, the less dense freshwater tends to flow above the sea surface. Helle et al. (1964) found that saline water penetrated the gravel at redd depth and that salinity was 9.3 ppt at the 11 ft tide level during a 14.5 ft tide. Thus, twice daily the intertidal zone eggs and yolk sac fry are alternately bathed in fresh and saline water of various salinities and for various exposure times. Helle et al. (1964) reported, however, that densities of live eggs and overwinter survival were progressively greater from lower to higher tide levels. Survival was nil at the 4 ft tide level, 20% at the 7 to 9 ft level, and 54% at the 10 to 11 ft level. Bailey (1966) reported that exposure of fertilized eggs to 28 ppt salinity for 4 hours twice daily had no apparent adverse effects, but when exposed to 6.7 hours twice daily mortality averaged 50%, and at 9.3 hours twice daily mortality was 100%. According to Hanavan and Skud (1954), however, survival of embryos in the 4 to 11.5 ft tidal area was equal to or greater than survival in the upstream freshwater area. Smith (1966) reported an average freshwater survival rate of 13.3% for Lakelse River pink salmon. Likewise, McNeil and Bailey (1975) state that pink salmon eggs can survive tidal inundation of 15 to 30 ppt salinity if there is periodic flushing with freshwater. Bailey (1966) reported from laboratory tests that pink salmon eggs fertilized, and water hardened, in 3.74 ppt sea water had a high incidence of deformed embryos; Helle et al. (1964) observed that spawning activity of pink salmon ceased when tidewater covered the spawning areas. Hence, salt water fertilization and hardening of pink salmon eggs may not be a serious problem. The above information yields the conclusion that the salinities acceptable to pink salmon embryos range from freshwater to about 28 ppt, when the twice-daily exposure times do not exceed 4 hours.

Pink salmon yolk sac fry are capable of surviving exposure to full strength sea water at time of hatching (Ishida 1966).

Emergent Fry Stage (Seaward Migrant)

Pink salmon fry emerge from the gravel mainly in April-June, but emergence and downstream migration begin as early as February and end as late as July (Divinin 1959; Sheridan 1962; Ishida 1967). The period of emergence and seaward migration usually coincides with the period of high stream runoff (Divinin 1959). Emergence from the gravel and downstream migration occur almost entirely at night, although some daylight migration may occur during the peak of the migration or in turbid waters (Divinin 1952; Neave 1963).

Normally, pink salmon fry enter salt water within a few hours after they emerge from spawning redds within a short distance of the ocean. Migrants not completing the seaward migration during the first night typically hide in the rocky substrate during daylight hours and continue the migration the following night (Sheridan 1962; Neave 1966). Seaward migrants travel alone rather than in schools; they do not school until they reach the estuary (Neave 1966).

Seaward migration has been observed at temperatures of 2 to 17°C and migration peaks at 6 to 12°C; however, Brett (1952) reported an upper lethal temperature for pink salmon fry of about 23°C and a preferred range of 10 to 16°C.

The typically short migration time enables one to conclude that a rocky substrate for daytime cover, freshet conditions, and a freshwater food supply may be helpful, but are not significant survival factors for pink salmon fry. However, temperature can be a significant factor in determining the freshwater survival and geographic distribution of the species. The acceptable temperature range selected here is 0 to 23°C and the optimum range is 2 to 16°C for seaward migrating pink salmon fry.

HABITAT SUITABILITY INDEX (HSI) MODELS

Figure 1 illustrates the assumed relationships among model variables, components, and the HSI for pink salmon.

HSI Model Applicability

Geographic area. The following models are applicable over the entire freshwater range of the pink salmon.

Season. The model rates the freshwater habitat of pink salmon by season of occupation for each model component; spawning adult; developing intergravel embryo and yolk sac fry; and emergent seaward migrating fry.

Cover types. The model is applicable to fresh and brackish water.

Minimum habitat area. Minimum habitat area is the minimum area of contiguous habitat that is required by a species to live and reproduce. Because pink salmon migrate to the sea immediately after emergence from the gravel, no maximal or minimal freshwater spawning area has been established, except that spawning densities probably should not exceed one pair per square yard of acceptable spawning habitat.

Habitat variables and suitability graphs

Model Component

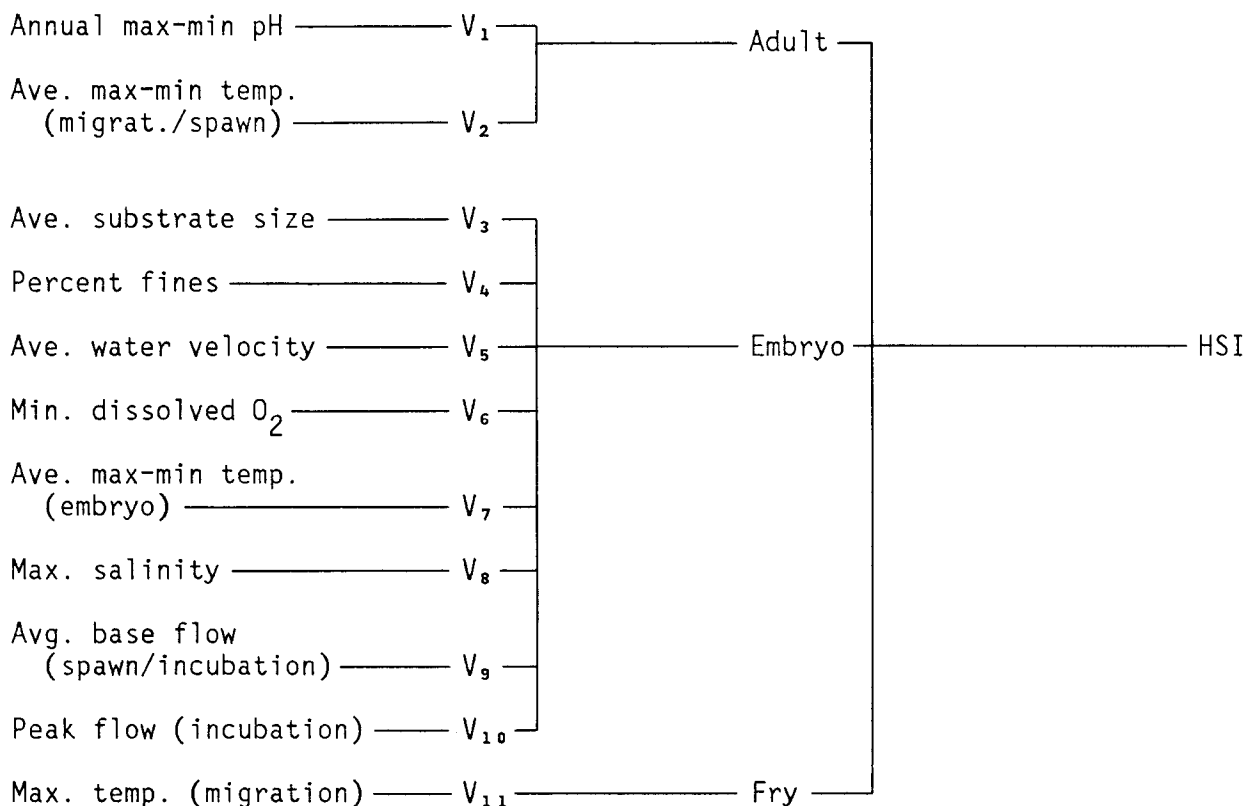

Figure 1. Diagram illustrating the relationship among model variables, components, and HSI.

Verification level. An acceptable performance for this pink salmon model is the production of an index between 0 and 1 that the primary author and other biologists familiar with pink salmon ecology believe is positively correlated with the long-term freshwater production of pink salmon fry. Model verification consisted of testing the model outputs from sample data sets developed by the authors and reviews by authorities on pink salmon.

Model Description

This pink salmon HSI model consists of three components: spawning adults (C_A), developing embryos (C_E), and seaward migrating fry (C_F). Each component contains variables specifically related to that component.

Two models are presented. In model 1, the limiting factor model, a simple limiting factor theory is used. The model assumption is that all

variables can have a significant effect on pink salmon survival and production, and that high SI scores of one or more variables cannot compensate for low SI scores of other model variables.

In model 2, the compensatory limiting factor model, a partial compensatory limiting factor theory is used. In this method, it is assumed that some compensation can occur among dependent variables.

Adult component. Adult pink salmon have a wide tolerance range for temperature, dissolved oxygen, and salinity. In unpolluted streams the variables of dissolved oxygen and salinity are not normally limiting factors to stream entry or spawning by adults. However, variables V_1 (pH) and V_2 (temperature) are included in the adult component of the model because extremes of either variable can delay or prevent stream entry and spawning by pink salmon.

Embryo component. Variables V_3 (average size of substrate) and V_4 (percent fines) are included because the substrate particles must be small enough to be moved by the female and the current in order to construct a hydraulically sound redd. Also, the substrate particle size must be large enough to allow adequate intergravel water flow and to allow yolk sac fry to emerge. Average water velocity (V_5) is included because adequate water flow is needed to carry dissolved oxygen (V_6) to the embryos and to remove metabolic wastes from the redd. Various studies have shown that too high or low water temperature (V_7) and salinities (V_8) can cause embryo mortality. Average annual base flow (V_9) is included because flows that are too low expose redds to dehydration and freezing of embryos. Also, flows that are too high (V_{10}) cause substrate movement that can result in mechanical injury or exposure of embryos.

Seaward migrating fry. Due to the typically short freshwater occupation and migration time of emergent fry, only one variable (V_{11}) maximum temperature, was included. High temperatures often cause high mortality. Yolk sac fry are capable of making the transition to seawater at time of hatching. The cover requirement for the typically short migration time and distance should be adequately met by the spawning substrate thus, cover was not considered to be a significant variable.

Suitability Index (SI) Graphs for Model Variables

This section contains SI graphs for 11 pink salmon riverine habitat variables. Instructions on where and when to take the habitat measurements to obtain valid SI scores are included with each SI graph. The habitat measurements and SI graph construction are based on the premise that extreme rather than average values of a variable most often limit the productivity of a habitat. Thus, extreme conditions, such as maximum temperatures and minimum dissolved oxygen concentrations, are often used in the graphs to derive SI values for the model. Other premises used to construct the SI graphs are discussed in the introduction. Instructions for obtaining an HSI score for pink salmon habitat from SI scores are included.

Variable

V₁ Annual maximal or minimal pH. Measure during summer to fall. Use the measurement with the lowest SI value.

Suitability graphs

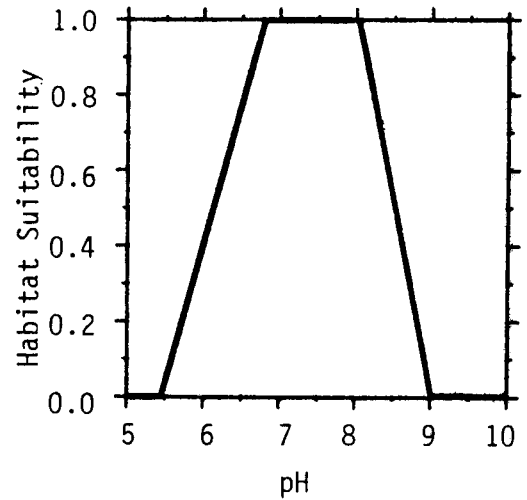

V₂ Maximal or minimal water temperature during the adult upstream migration and spawning period. Measure in downstream areas during stream entry and migration period, and on the spawning grounds during the spawning period. Use the measurement with the lowest SI score.

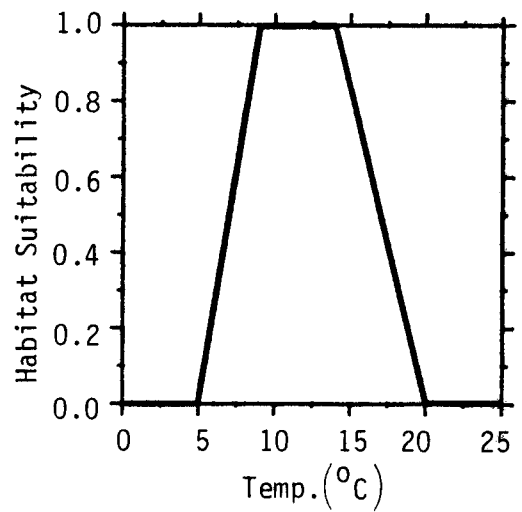

V₃ Average size of substrate particles (cm). Measure in gravel bottom areas of stream used by spawning pink salmon during the spawning season and only where the water depth is ≥ 15 cm.

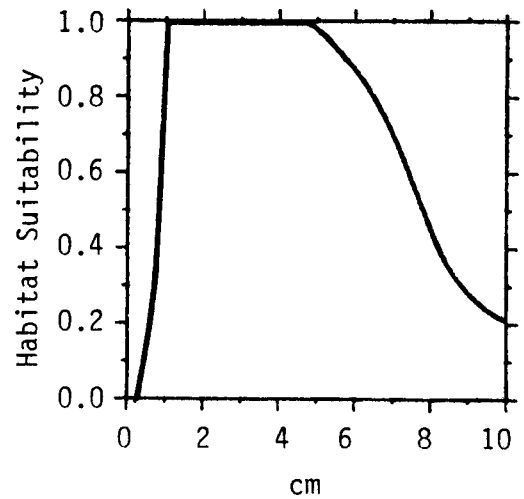

Variable

V₄ Percent fines (< 0.3 cm). Measure at the same time and sites as V₃.

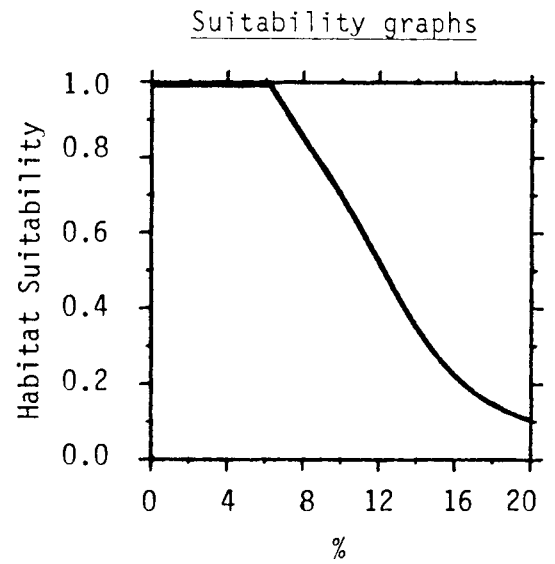

V₅ Average water column velocities for spawning and embryo incubation. Measure at the same time and sites as V₃.

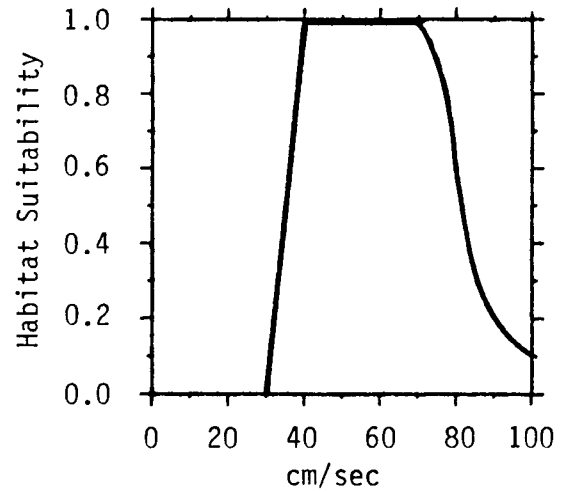

V₆ Minimal dissolved O₂ level during the egg incubation and preemergent yolk sac fry period. Measure at time of highest temperatures during the incubation period.

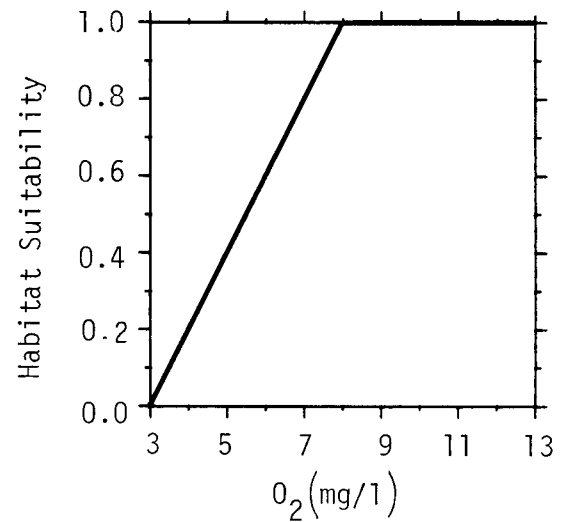

Variable

V₇ Maximal or minimal water temperatures during the early embryo development period. Measure on the spawning area within the first 10 days after spawning commences. Use the measurement with the lowest SI score.

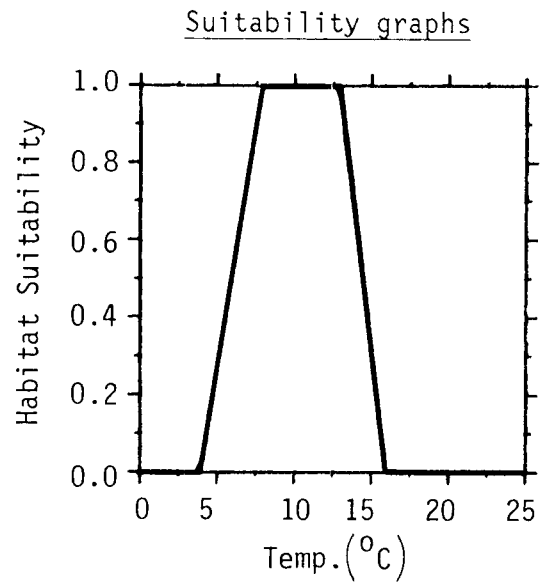

V₈ Maximal salinity during the early embryo development period. Measure intergravel at egg depth at or near the four hour tide exposure level.

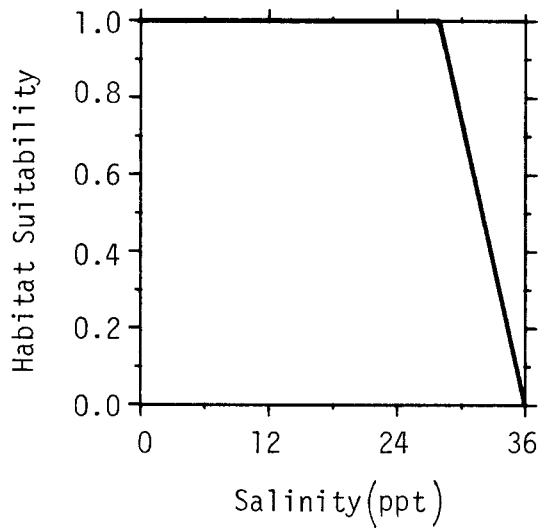

V₉ Average base flow during the embryo incubation period as a percentage of the average daily flow during spawning. Measure during peak spawning and at incubation low flow periods.

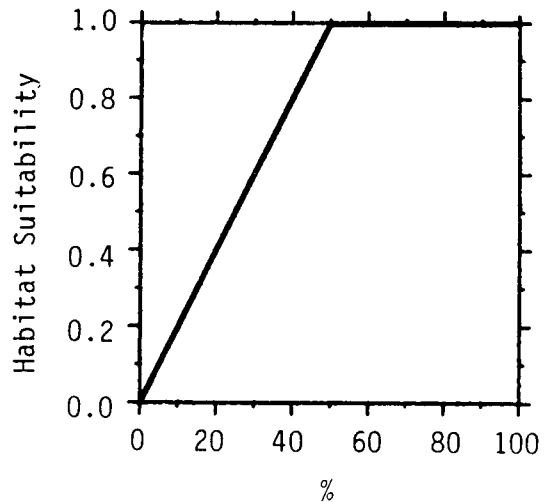

Variable

V_{10} Peak flow during incubation period as a multiple of the average base flow (as in V_9).

Suitability graphs

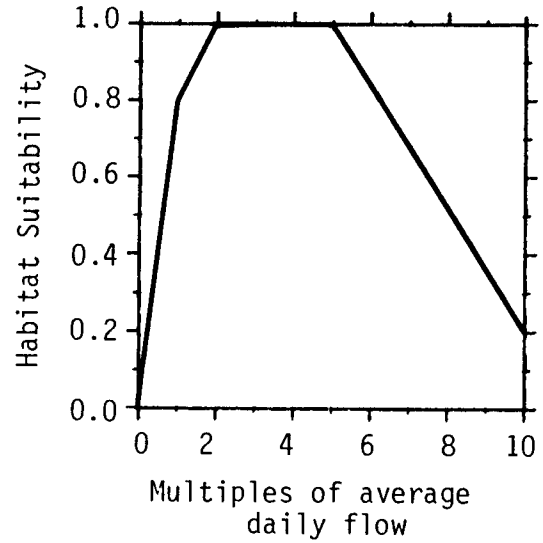

V_{11} Maximum temperature during the period of seaward migration. Measure in downstream areas in the post-peak migration period during the hottest period of the day; usually mid-afternoon.

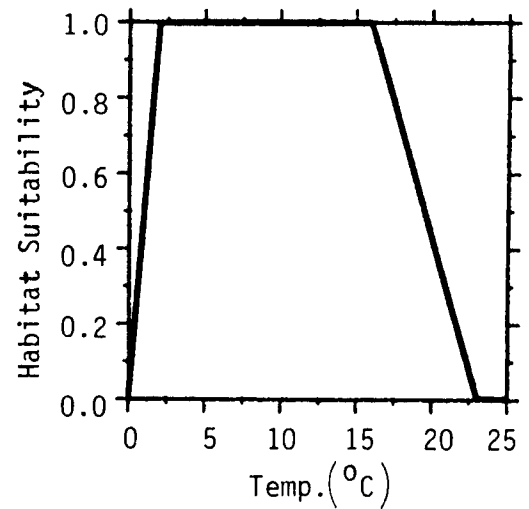

The data sources and assumptions used to construct the pink salmon suitability graphs are summarized in Table 1.

Table 1. Specific habitat requirements, sources, and assumptions.

Variable and sources	Assumptions
V ₁ Behnke and Zarn 1976 Ishida 1966	Ranges of pH selected by most trout and salmon were considered applicable to pink salmon, and the pH concentrations correlated with abundant pink salmon populations were considered to be the optimal range.
V ₂ Divinin 1952; Kuznetsov 1928; Semko 1939	Water temperature extremes can prevent stream entry and spawning. Temperatures associated with normal stream entry and spawning were considered optimal.
V ₃ Andrew and Geen 1960; Chambers 1956; Neave 1966; and Semko 1939.	The substrate sizes selected by adult spawners were considered to constitute the size range of gravel used. The gravel sizes correlated with high embryo survival and fry emergence was considered optimal.
V ₄ McNeil and Ahnell 1964; Wickett 1962	The percent fines associated with the highest survival of embryos and emergent fry was considered optimal. Those associated with high mortality were considered suboptimal.
V ₅ Andrew and Geen 1960; Divinin 1952; Ishida 1966.	Average water velocities most often selected by adults and those associated with high embryo survival were considered optimal.
V ₆ Doudoroff and Shumway 1970; Ishida 1966; McNeil 1966; Nikol'skii and Soin 1954.	Dissolved oxygen concentrations associated with normal development and high survival of embryos were considered optimal. Those associated with development abnormalities and high mortality of salmonid embryos were considered suboptimal.
V ₇ Bailey and Evans 1971 Bell 1973; Divinin 1952; Petrenko 1964; Sheridan 1962; Semko 1939; McNeil 1968; Bailey 1985	Maximum and minimum temperatures associated with high embryo survival and normal time of fry emergence were considered optimal. Those associated with poor survival or time of emergence were suboptimal.
V ₈ Bailey 1966; Hanovan and Skud 1954; Helle et al. 1964; Ishida 1966; McNeil and Bailey 1975	Maximum salinities of ≤ 4 hours exposure duration associated with high embryo survival and a low incidence of deformities were optimal. Higher salinities with greater exposure times were progressively further from optimum.

Table 1. (concluded)

Variable and sources	Assumptions
V ₉ Andrew and Geen 1960; Binns and Eiserman 1979; Lister and Walker 1966; Sheridan and McNeil 1960; Tennant 1976; Wesche 1980.	Average base flows during embryo incubation as a percentage of average daily flows associated with high salmonid embryo survival were considered excellent; intermediate base flows were considered fair to good; and base flows of < 25% were considered poor.
V ₁₀ Andrew and Geen 1960; Lister and Walker 1966; Nehring and Anderson 1982, 1983; Sheridan and McNeil 1960, 1968	Embryo incubation season peak flows of two to five times greater than the average base flow were considered to be excellent, but increasingly higher flows were considered to be progressively worse.
V ₁₁ Brett 1952; Divinin 1952; Ishida 1967; Semko 1939.	The range of maximum temperatures were those over which seaward migrations had been observed with an upper tolerance level and an optimal range of preferred temperatures for pink salmon fry as reported by Brett.

Model 1, Limiting Factor

The limiting factor model assumes that each variable in the model can significantly affect the suitability of the habitat to produce pink salmon; that high SI values in some variables cannot compensate for low SI values in other variables; and that the species HSI thus cannot exceed the lowest SI value for any variable. The Limiting Factor Model method would yield a pink salmon HSI of 0.5 for the habitat represented by the SI values shown in Table 2.

Model 2, Compensatory Limiting Factor

This model encompasses the same assumptions as Model 1 except for the following modifications. It is assumed that an SI of 1.0 for variables V_4 (percent fines) or V_5 (average water velocity) will increase the SI scores of variables V_3 (average substrate size) and V_4 by 0.1 if the scores of these variables are ≥ 0.3 before the increase. No variable can exceed 1.0.

If the above modification is used, this model would yield a pink salmon HSI of 0.6 for the habitat represented by the SI scores in Table 2.

Interpreting Model Outputs

The individual variable SI scores can be used to direct efforts to manage habitat for pink salmon. Habitat variables with low SI scores may indicate where management resources should be applied to gain the greatest return per dollar expended in terms of increased pink salmon production from the fresh-water environment. Comparison of individual variable SI scores prior to and following construction of water based projects will provide an excellent basis for determining project impacts and guiding mitigation and enhancement efforts.

The single pink salmon HSI score for the habitat being evaluated is only a relative indicator of habitat suitability. The above models in their present form are not intended to predict production levels of pink salmon per unit of spawning area or per unit of potential egg deposition throughout the pink salmon range. It is not yet known how each variable should be weighted in terms of its potential impact on the other variables, or on the overall production potential of the habitat. Knowledge of such interactions must await further studies. Perhaps some simple correlations can be made between HSI scores and habitat production potential among stratified spawning habitat types, but this possibility has not been tested. If the model is correctly structured, a high HSI score would indicate near optimal habitat conditions for pink salmon production for the variables included in the model, intermediate HSI scores would indicate intermediate habitat conditions; and low HSI scores, poor habitat conditions. An HSI of 0.0 does not necessarily mean that the species is not present; it does mean that the habitat is very poor for one or more variables and that the species is likely to be scarce, if not absent.

Table 2. Matrix table to display suitability indices^a (SI's) for pink salmon habitat variables.

Variables	Adult (Spawner)		Embryo (Intergravel)		Fry (Migrant)	
	Data	SI	Data	SI	Data	SI
V ₁ Max-min pH	7.2	1	-	-	-	-
V ₂ Max-min temp (adult)	12	1	-	-	-	-
V ₃ Ave. substrate size	-	-	7	0.7	-	-
V ₄ % fines	-	-	12	0.5	-	-
V ₅ Ave. water vel.	-	-	60	1	-	-
V ₆ Min. dissolved O ₂	-	-	8	1	-	-
V ₇ Max-min temp (embryo)	-	-	4.5	1	-	-
V ₈ Max. salinity	-	-	15	1	-	-
V ₉ Ave. base flow	-	-	60	1	-	-
V ₁₀ Ave. peak flow	-	-	7	0.7	-	-
V ₁₁ Max. temp (fry)	-	-	-	-	10	1

^aThe data sets in this table are from measurements assumed by the author. The corresponding SI values are from the pink salmon SI graphs.

INSTREAM FLOW INCREMENTAL METHODOLOGY

The Instream Flow Incremental Methodology (IFIM) was designed to quantify changes in the amount of habitat available to different species and life stages of fish (or macroinvertebrates) under various flow regimes (Bovee 1982). The IFIM can be used to help formulate instream flow recommendations, to assess the effects of altered streamflow regimes, habitat improvement projects, mitigation proposals, and fish stocking programs; and to assist in negotiating releases from existing water storage projects. The IFIM has a modular design, and consists of several autonomous models that are combined and linked as needed by the user. One major component of the IFIM is the Physical Habitat Simulation System (PHABSIM) model (Milhous et al. 1984). The output from PHABSIM is a measure of physical microhabitat availability as a function of discharge and channel structure for each set of habitat suitability criteria (SI curves) entered into the model. The output can be used for several IFIM habitat display and interpretation techniques, including the following three:

1. Habitat Time Series. Determination of impact of a project on a species' life stage habitat by imposing project operation curves over baseline flow time series conditions and integrating the difference between the corresponding time series.
2. Effective Habitat Time Series. Calculation of the habitat requirements of each life stage of a single species at a given time by using habitat ratios (relative spatial requirements of various life stages).
3. Optimization. Determination of flows (daily, weekly, and monthly) that minimize habitat reductions for a complex of species and life stages of interest.

Suitability Index Curves as Used in IFIM

Suitability Index (SI) curves used in PHABSIM describe the instream suitability of the habitat variables most closely related to stream hydraulics and channel structure (e.g., velocity, depth, substrate, cover, and temperature) for each major activity of a given fish species (e.g., spawning, egg incubation, larval, juvenile, and adult). The Western Energy and Land Use Team has designated four categories of curves and standardized the terminology pertaining to the curves (Armour et al. 1984). Category one curves are based on literature sources or professional opinion. Category two (utilization) curves, based on frequency analyses of field data, are fit to frequency histograms. Category three (preference) curves are utilization curves from which the environmental bias has been removed. Category four (conditional preference) curves describe habitat requirements as a function of interaction among variables. The designation of a curve as belonging to a particular category does not imply that the quality or accuracy of curves differ among the four categories.

Availability of SI Curves for Use in IFIM

The SI curves available for IFIM analyses of pink salmon habitat are category one and two, based on combinations of judgment, information derived from the literature, and field data. Investigators are encouraged to review the curves carefully and verify them before they use them in IFIM analyses.

Spawning migration. Migration of pink salmon to spawning areas generally occurs at some time between June and September, depending on locale (Scott and Crossman 1973). SI curves for migration (Fig. 2) are category one, based on information in the literature. Minimum water depths necessary for passage were reported to range from 0.3 to 0.6 ft (Kreuger 1981; Wilson et al. 1981). Maximum velocities through which pink salmon can migrate were reported as 6.6 ft/s (Kreuger 1981). Bell (1973) stated that migration may be delayed at water temperatures greater than 70°F, and that upstream spawning migration generally occurs at temperatures of 45 to 60°F. No information was found that might indicate that substrate or cover was important for spawning migration, and no curves were developed.

SI curves for migration should be used for the time period during which migration occurs in a given study area. Critical reaches that may block spawner passage due to insufficient water depth, high water velocities, or high water temperatures should be identified in each stream of interest, from the stream mouth to the furthest upstream spawning areas.

Spawning and egg incubation. Pink salmon generally spawn some time between July and October, depending on locale, egg incubation may require 63 to 110 days, depending on water temperature. Therefore, SI Curves should be used for the period during which spawning and egg incubation occur in a given area.

There are two approaches for determining the amount of spawning/egg incubation habitat for a stream reach. One approach treats spawning and egg incubation as separate life stages, each with its own set of habitat suitability criteria, and assumes that weighted useable area does not vary by more than 10% during the spawning and egg incubation periods. In this case, pink salmon spawning and egg incubation curves are combined (Fig. 3), assuming that no significant difference in physical microhabitat requirements exists between the two life stages (e.g., depths and velocities suitable for spawning are also suitable for egg incubation).

Three data sets were used to develop the category one SI curves for pink salmon spawning velocity and depth suitability. Kurko (1977) collected data between river miles 59 and 93 on the upper Skagit River in northcentral Washington from 24 September to 23 October 1975. He used boat surveys to locate spawners and, where adult spawners were present, measured water depth and velocity (at 0.5 ft above the stream bottom) at the upstream lip of each redd. No substrate data were collected. Mean annual flows of the Skagit River ranged from 4,486 cfs at the upper end of the river segment to 12,500 cfs at the lower end; flows during spawning generally ranged from 1,000 to 2,000 cfs.

Coordinates

<u>x</u>	<u>y</u>
0.0	1.0
4.0	1.0
6.7	0.0
100.0	0.0

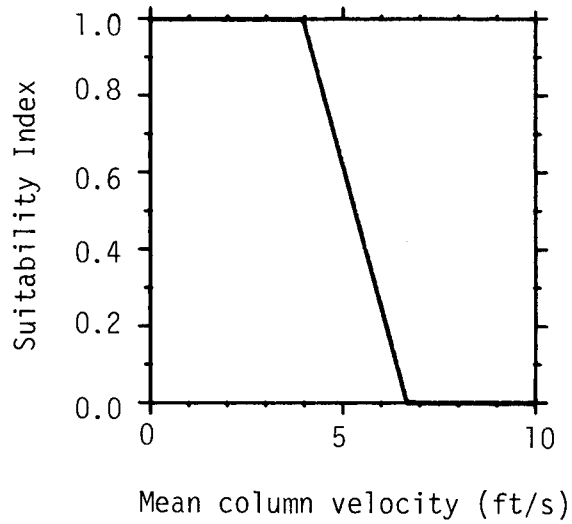

<u>x</u>	<u>y</u>
0.0	0.0
0.2	0.0
0.6	1.0
100.0	1.0

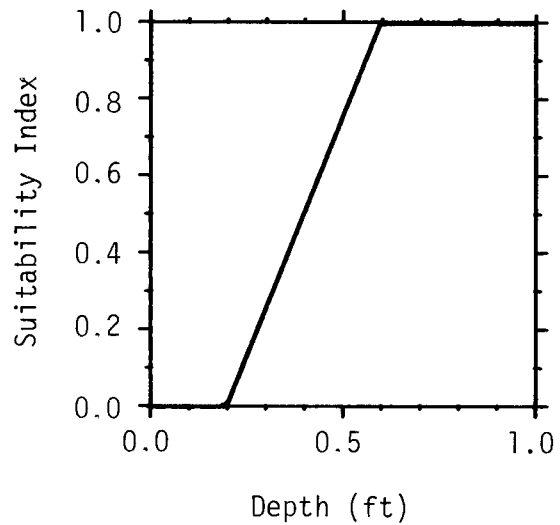

<u>x</u>	<u>y</u>
0.0	0.0
41.0	0.0
45.0	1.0
60.0	1.0
70.0	0.0
100.0	0.0

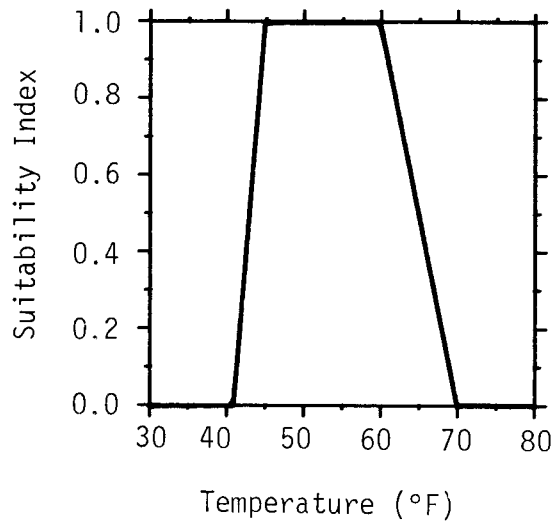
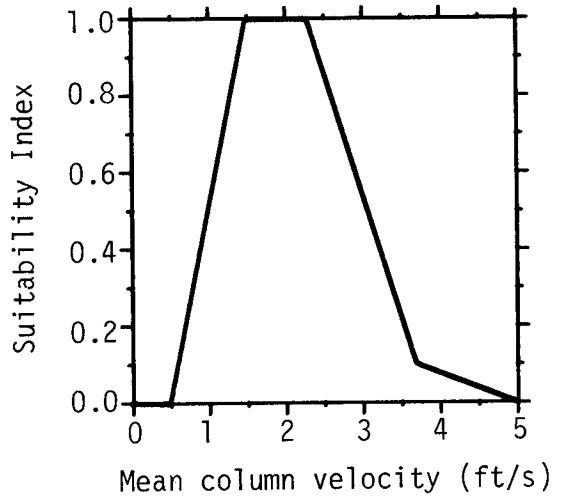

Figure 2. Category one SI curves for pink salmon adult spawning migration velocity, depth, and temperature suitability.

Coordinates

<u>x</u>	<u>y</u>
0.0	0.0
0.5	0.0
1.5	1.0
2.3	1.0
3.7	0.1
5.0	0.0



<u>x</u>	<u>y</u>
0.0	0.0
0.3	0.0
1.2	1.0
100.0	1.0

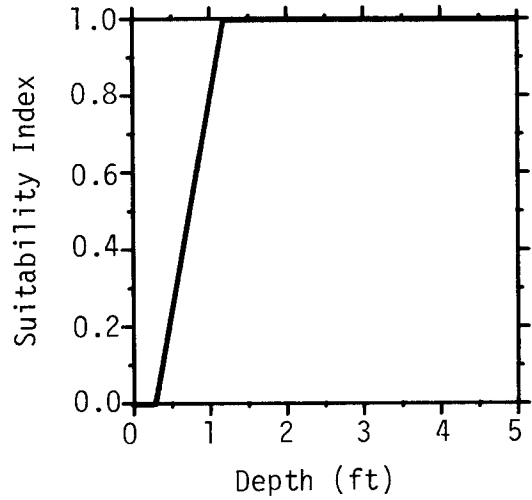

<u>x</u>	<u>y</u>
0.0	0.0
0.1	0.0
0.4	1.0
2.0	1.0
2.4	0.9
2.8	0.7
3.1	0.5
3.5	0.3
5.5	0.0
100.0	0.0

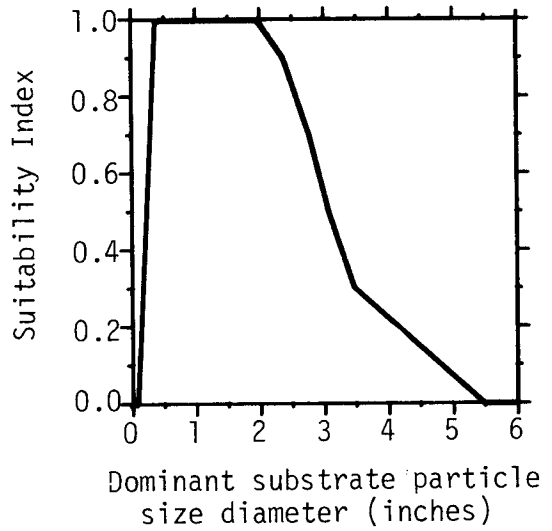
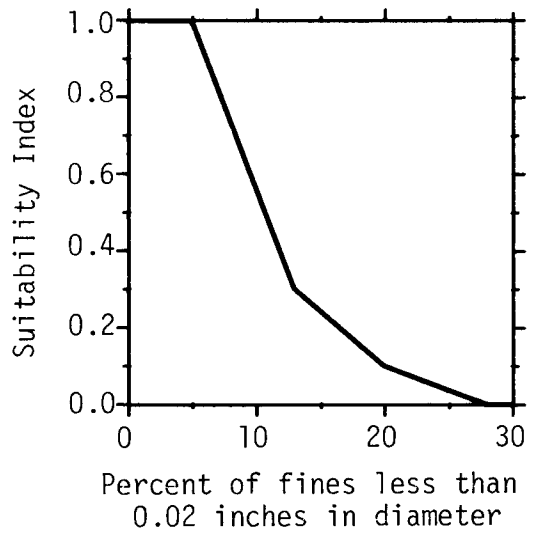

Figure 3. Category one SI curves for pink salmon spawning and egg incubation velocity, depth, substrate, and temperature suitability.

Coordinates

<u>x</u>	<u>y</u>
0.0	1.0
5.0	1.0
13.0	0.3
20.0	0.1
28.0	0.0
100.0	0.0



<u>x</u>	<u>y</u> (spawning; solid line)	<u>y</u> (egg incubation; broken line)
0.0	0.0	0.0
37.4	-	0.0
41.0	0.0	1.0
48.0	1.0	-
50.0	-	1.0
57.0	1.0	-
66.0	-	0.0
68.0	0.0	-
100.0	0.0	0.0

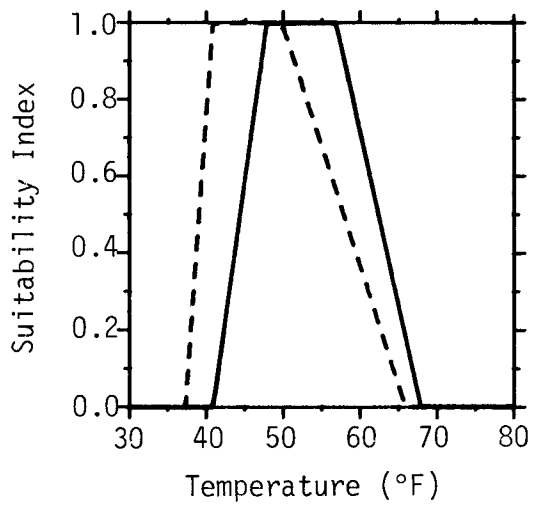

Figure 3. (concluded)

Wilson et al. (1981) collected data at 14 study reaches within the Terror and Kizhuyak River basins of Kodiak Island, Alaska, from March 1980 to February 1981. Adult spawners were located by visual sighting, and measurements were taken at sites where females were fanning or digging, at sites where male and female pairs exhibited territorial behavior, or at sites where an individual adult remained over an excavated depression. Water depth and mean velocity were measured at each point where a fish or redd was observed (at the upstream lip of each redd). Substrate was characterized within a 10 ft² area, and substrate codes included the largest particle sizes, percent embeddedness, and the particle sizes of the smaller particles within which the largest particles were embedded. Frequency analyses were performed on all of the data (n=815). Eight of the study sites are described in Table 3.

Nadeau (1984) collected data on spawning pink salmon (n=407) from seven sites on the Wilson and Blossom Rivers and Tunnel Creek, Alaska. Mean water velocities and total depths were measured at the upstream lip of each redd where a pink salmon female was seen. Dominant and subdominant particle sizes were identified and coded. Frequency analyses were performed on the habitat utilization and availability data to determine habitat preference. Utilization and preference curves were superimposed to develop hybrid curves.

Investigators must review the category one and category two velocity and depth curves (Figs. 3 and 4) and decide which ones are most appropriate for use in their study area. The category two curves from Kurko (1977) may be applicable for larger rivers like the Skagit (1000 to 2000 cfs); curves from Wilson et al. (1981) may be more applicable for smaller rivers (100 to 500 cfs); and curves from Nadeau (1984) may be appropriate for intermediate-size rivers. The category one curves (Fig. 3) are a composite of the site-specific category two curves (Fig. 4), are much broader, and therefore are meant to represent general spawning habitat requirements throughout the range of pink salmon.

The SI curves for spawning substrate suitability (Fig. 3) were taken from the HSI model section of this report (V3 and V4; sources and assumptions in Table 1). Substrate particle sizes selected by spawning pink salmon may be a function of several factors, including size of spawners, substrate availability, spawner density, water velocity, and upwelling. Diameters of substrate particles used by spawners have been reported to range from 0.2 to 3.9 inches (Krueger 1981), and from 0.1 to 9.8 inches (Wilson et al. 1981). In certain situations, however, spawners may use substrate types that are not suitable for the survival and development of embryos and intergravel larvae. Therefore, the SI curves for spawning substrate suitability are also meant to represent substrate requirements of eggs and fry.

The SI curves showing suitable temperatures for spawning and egg incubation were taken from the HSI model section of this report (V₂ and V₇; sources and assumptions in Table 1). Preferred spawning temperatures may differ locally, but the curve generally agrees with information developed by Hunter (1959), Sheridan (1962), Bell (1973), and Krueger (1981). The curve for egg incubation is meant to represent embryo survival as a function of temperature.

Table 3. Description of Terror and Kuzhuyak River basin study sites where data were collected for development of pink salmon spawning SI curves (Wilson et al. 1981).

Study site	Range of average monthly flows (cfs)	Dominant substrate types	Dominant cross section type	Range in stream width (ft)	Maximum depth (ft)
Upper Terror	50-614	large cobble to boulder	triangular	50-90	4
Bear Meadow	25-211	small cobble and medium gravel	rectangular	25-45	4
Log Jam	10-482	large gravel to small cobble	variable	30-100	5
Terror Gage	50-822	small cobble, gravel, sand	parabolic to triangular	30-100	4
Upper Kizhuyak	24-370	large cobble, boulder	rectangular	20-60	2
Dry Channel	0-455	variable, sand to boulder	triangular	20-130	6
Kizhuyak Gage	30-620	medium gravel to small cobble	triangular	50-130	5
Kizhuyak Delta	40-600	sand, medium to large gravel	parabolic	30-120	4

Coordinates

x	y (Kurko 1977; solid line)	y (Wilson et al. 1981; dashed line)	y (Nadeau 1984; dot/dash line)
0.0	0.00	0.0	0.0
0.1	--	0.1	-
0.4	--	0.4	-
0.7	0.04	-	-
1.0	--	1.0	-
1.3	0.50	-	-
1.5	--	-	1.0
2.0	--	1.0	-
2.3	1.00	-	1.0
2.5	--	0.5	-
3.1	0.40	-	-
3.5	--	0.1	0.2
3.7	0.10	-	-
4.0	--	-	0.1
5.0	0.00	0.0	0.0

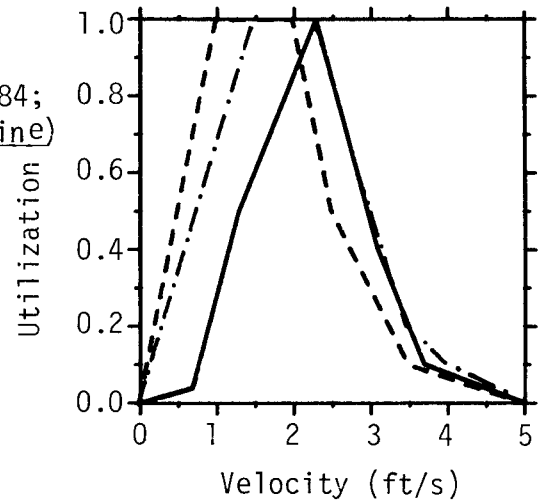

x	y (Kurko 1977; solid line)	y (Wilson et al. 1981; dashed line)	y (Nadeau 1984; dot/dash line)
0.0	0.00	0.0	0.0
0.1	--	0.0	-
0.3	0.00	-	-
0.5	0.02	-	-
0.8	0.46	-	0.8
1.0	--	1.0	1.0
1.5	1.00	-	-
1.9	0.94	-	-
2.3	0.38	-	-
2.5	--	1.0	-
3.0	--	0.5	-
3.3	0.20	-	-
3.7	0.04	-	-
4.0	--	0.1	-
4.3	0.01	-	-
5.0	0.00	0.0	-
15.0	--	-	1.0
30.0	--	-	0.0
100.0	0.00	0.0	0.0

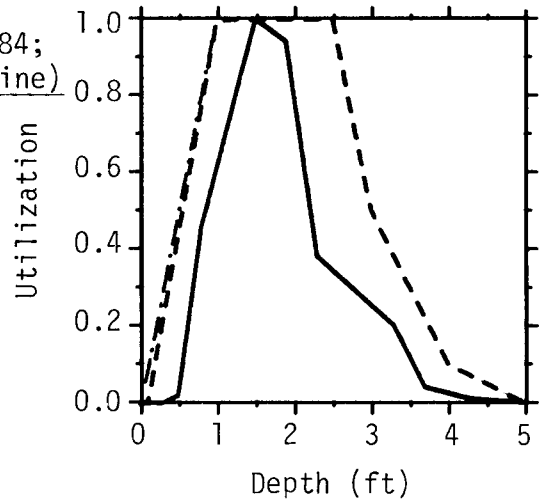
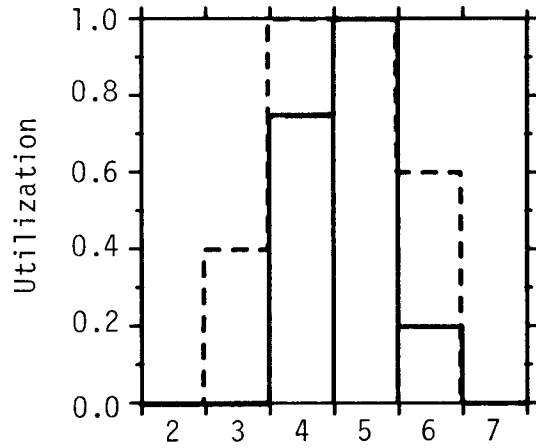

Figure 4. Category two SI curves for pink salmon spawning velocity, depth, and substrate utilization from three separate data sets.



<u>x</u>	<u>Particle type and diameter (mm)</u>	<u>y</u> (Wilson et al. 1981; solid line)	<u>y</u> (Nadeau 1984; dashed line)
0	Detritus	0.00	0.0
1	Silt/clay <0.062	0.00	0.0
2	Sand 0.062 - 2	0.00	0.0
3	Fine gravel 2 - 8	0.00	0.4
4	Medium gravel 8 - 32	0.75	1.0
5	Coarse gravel 32 - 64	1.00	1.0
6	Small cobble 64 - 130	0.20	0.6
7	Large cobble 130 - 250	0.00	0.0
8	Boulder >250	0.00	0.0
9	Bedrock solid rock	0.00	0.0

Figure 4. (concluded)

No information found in the literature suggested that cover was a requirement for pink salmon spawning. It was therefore assumed that no curve is necessary.

In the second approach for determining spawning and egg incubation habitat, effective spawning habitat is measured (Milhous 1982). This approach is recommended when weighted usable area varies by more than 10% during the spawning and egg incubation period, as a result of streamflow variation. Effective spawning habitat remains suitable throughout the spawning and egg incubation period. In a given stream reach, the area of effective spawning habitat is equal to the area of suitable spawning habitat minus the spawning habitat area that was dewatered, scoured, or silted-in during egg incubation. Factors to consider when determining habitat reduction because of dewatering include the depth of the eggs within the streambed, temperature and dissolved oxygen requirements of incubating eggs, and the requirements for fry emergence. To determine habitat reduction from scouring, the critical scouring velocity (Fig. 5) can be determined by the following equation:

$$V_c = 22.35 \left(\frac{d_{bf}}{D65} \right)^{1/6} [K_s (S_s - 1)]^{1/2} (D65)^{1/2}$$

where V_c = critical velocity in ft/s

d_{bf} = average channel depth (ft) at bankfull discharge

D65 = substrate particle size diameter (ft) not exceeded by 65% of the particles

K_s = 0.080, a constant pertaining to the general movement of the surface particles

S_s = specific gravity of the bed material, and ranges from 2.65 to 2.80

Factors to consider when determining habitat reduction from siltation include suspended sediment concentrations, minimum velocities necessary to prevent siltation (Fig. 5), and dissolved oxygen concentrations among the embryos. More detailed information about the analysis of effective spawning habitat was presented in Milhous (1982).

Coordinates	
<u>x</u>	<u>y</u>
0	0
Vmin-.001	0
Vmin	1
Vc	1
Vc+.001	0
100	0

Vmin is the minimum velocity necessary to prevent siltation of spawning sites; Vc is the critical velocity, above which scouring of spawning sites will occur.

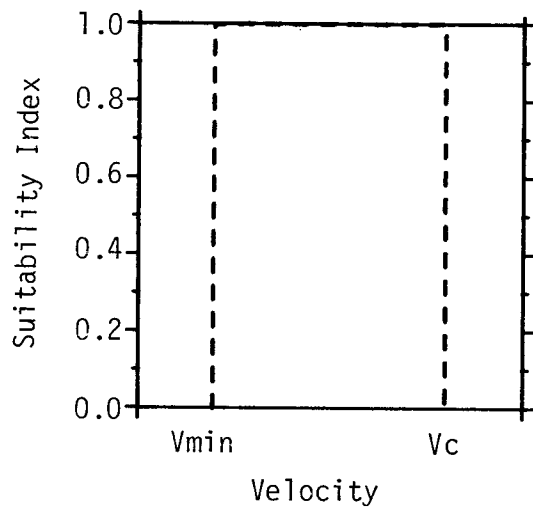

<u>x</u>	<u>y</u>
0	0
Dmin-.001	0
Dmin	1
100	1

Dmin is either the minimum depth required for egg incubation (≥ 0.0) or ice depth (when ice is present during egg incubation).

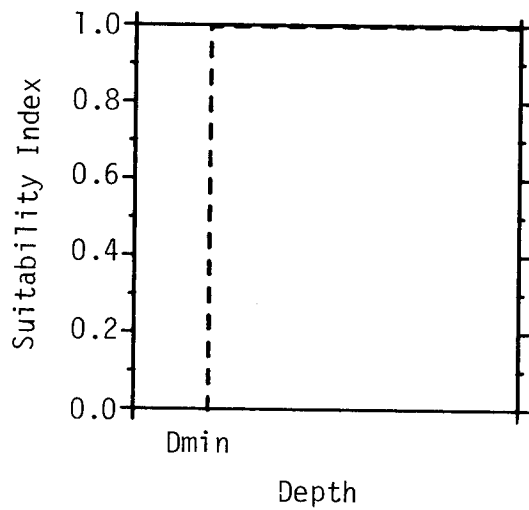

Figure 5. SI curves for spawning/egg incubation velocity and depth, for effective spawning habitat analyses.

Of the two approaches for determining spawning and egg incubation habitat, the second effective spawning habitat approach is recommended for pink salmon. In most streams (except spring-fed streams), weighted usable area probably varies by more than 10% during the long period required for completion of the egg incubation and intergravel fry stages. For a given study area, the amount of suitable spawning habitat can be quantified by using the spawning curves for category one (Fig. 3) or category two (Fig. 4); the net suitable habitat may then be simulated for different flow regimes by using the effective spawning habitat analyses.

Fry. After hatching, fry may remain in the gravel for 80 to 120 days (Kuznetsov 1928). The habitat requirements of intergravel fry are therefore assumed to be the same as for incubating eggs. The effective spawning habitat analysis may be used to determine how much of the suitable spawning and egg incubation habitat remained suitable for intergravel fry, from the onset of spawning through the end of the fry emergence period.

Upon emergence, fry immediately begin downstream migration over distances of 0 to 300 miles (Neave 1963; Helle et al. 1964). Fry migrate at night and hide in the substrate during the day (Hoar 1956). Emerged fry are 1 to 2 inches long and substrate particle-size diameters ranging from 2 to 12 inches are therefore considered suitable for daytime cover and substrate (Fig. 6). Water velocities of 0.5 to 3.0 ft/s are considered suitable for combinations of both passive displacement and active migration. Higher velocities in shallow water may result in fry mortality from abrasion by the substrate. The minimum water depths considered suitable for passage depend on water velocities and substrate types. Depths greater than 0.5 ft are considered suitable in areas of low turbulence. The SI curve for suitability of fry migration temperature was taken from the HSI model section of this report (V_{11} ; sources and assumptions in Table 1).

Summary. A species periodicity chart should be developed for the study area before an IFIM analysis is undertaken, to determine when and where habitat is required for each of the life stages. All SI curves for IFIM analyses of pink salmon habitat should be reviewed carefully before use. If any of the curves are believed not to be representative of local conditions and situations, they will require modification. Field verification is recommended.

Coordinates	
<u>x</u>	<u>y</u>
0.0	0.2
0.5	1.0
3.0	1.0
5.0	0.0
100.0	0.0

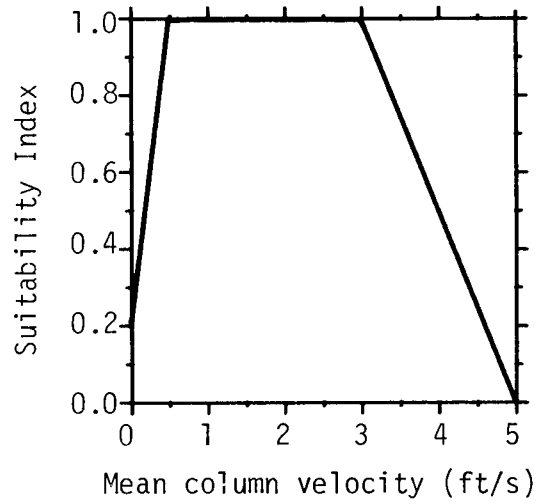

<u>x</u>	<u>y</u>
0.0	0.0
0.5	1.0
100.0	1.0

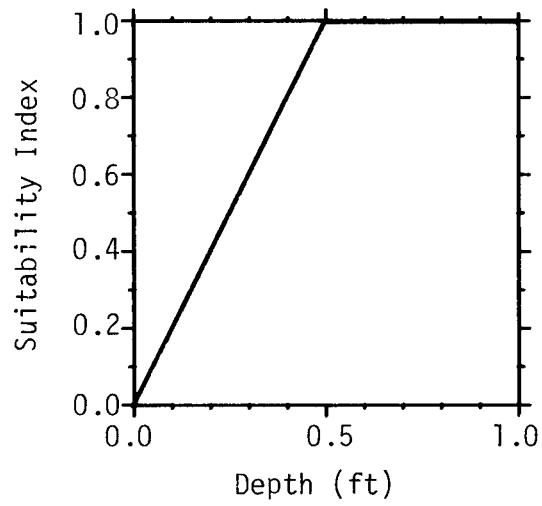

<u>x</u>	<u>y</u>
0.0	0.0
0.5	0.0
2.0	1.0
12.0	1.0
20.0	0.0
100.0	0.0

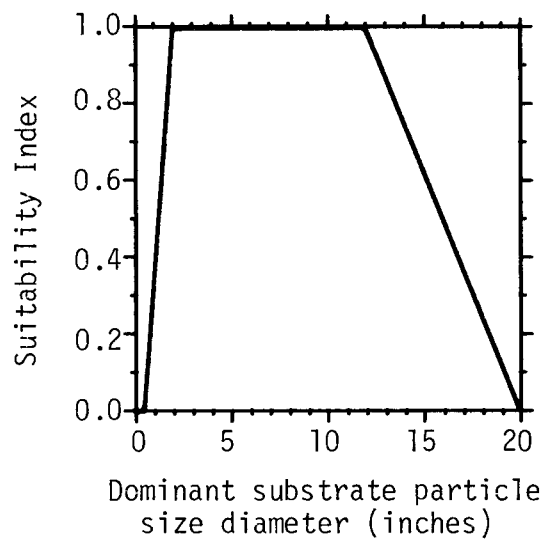

Figure 6. Category one SI curves for pink salmon fry migration velocity, depth, substrate, and temperature suitability.

Coordinates

<u>x</u>	<u>y</u>
0.0	0.0
32.0	0.0
36.0	1.0
61.0	1.0
73.0	0.0
100.0	0.0

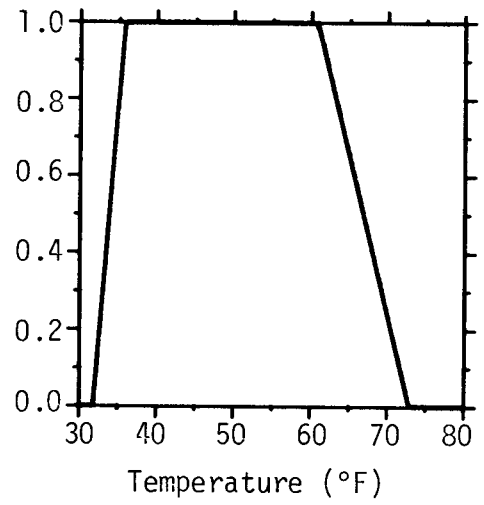

Figure 6. (concluded)

REFERENCES

- Andrew, T. J., and G. H. Geen. 1960. Sockeye and pink salmon production in relation to proposed dams in the Fraser River system. Int. Pacific Fish. Comm., New Westminster, B.C. Can. Bull. XI. 259 pp.
- Armour, C. L., R. J. Fisher, and J. W. Terrell. 1984. Comparison of the use of the Habitat Evaluation Procedures (HEP) and the Instream Flow Incremental Methodology (IFIM) in aquatic analyses. U.S. Fish Wildl. Serv. FWS/OBS-84/11. 30 pp.
- Atkinson, C. E., J. H. Rose, and T. O. Duncan. 1966. Pacific Salmon in the United States. Pages 43-223 in Int. N. Pacific Fish. Comm. Salmon of the No. Pacific Ocean. Part IV. Vancouver, Canada, 1967.
- Bailey, J. E. 1966. Effects of salinity on intertidal pink survival. Pages 12-15 in Proceedings of the 1966 Northeast Pacific Pink Salmon Work. Alaska Dept. Fish. Game, Juneau.
- Bailey, J. E., and D. R. Evans. 1971. The low temperature threshold for pink salmon eggs in relation to a proposed hydroelectric installation. Fish. Bull. U.S. 69:587-593.
- Behnke, R. J., and M. Zarn. 1976. Biology and management of threatened and endangered western trout. U.S. For. Serv. Gen. Tech. Rep. RM-28. 45 pp.
- Bell, M. C. 1973. Fisheries handbook of engineering requirements and biological criteria. Fish. Eng. Resour. Prog. U.S. Army Corps Eng. Div., Portland, OR.
- Binns, N. A., and F. M. Eiserman. 1979. Quantification of fluvial trout habitat in Wyoming. Trans. Am. Fish. Soc. 108(3): 215-228 pp.
- Bovee, K. D. 1982. A guide to stream habitat analysis using the Instream Flow Incremental Methodology. Instream Flow Information Paper 12. U.S. Fish Wildl. Serv., FWS/OBS-82/26. 248 pp.
- Brett, J. R. 1952. Temperature tolerance in young Pacific salmon, genus Oncorhynchus. J. Fish. Res. Bd. Can. 9(6):265-323 pp.
- Canada Department of Fisheries. 1959. Annual report for 1957-1958. 93 pp.
- Chambers, J. S. 1956. Research relating to study of spawning grounds in natural areas. U.S. Army Corps. Eng. No. Pac. Div. Fish Eng. Res. Prog. 88-94 pp.
- Davidson, F. A., E. Vaughan, S. J. Hutchinson, and A. L. Pritchard. 1943. Factors influencing the upstream migration of pink salmon (Oncorhynchus gorbuscha). Ecology Vol. 24(2) 149-168 pp.
- Divinin, P. A. 1952. The salmon of South Sakhalin. Izvestiia Tikhookeanskogo Nauchno - Issledovatel'skogo Instituta Rybnogo Khoziaistvo i Okeanografii (Izv. TINRO) 37:69-108.

- Divinin, P. A. 1959. Some characteristics of pink salmon fry in Sakhalin streams during their downstream migration. Zoologicheskii Zhurnal 38(8) 1268-1269.
- Doudoroff, P., and D. L. Shumway. 1970. Dissolved oxygen requirements of freshwater fishes. FAO. Fish. Tech. Pap. 86. 291 pp.
- Hanavan, M. G., and B. E. Skud. 1954. Intertidal spawning of pink salmon. U.S. Fish. Wildl. Serv., Fish. Bull. 56:167-186.
- Helle, J. H., R. S. Williamson, and J. E. Bailey. 1964. Intertidal ecology and life history of pink salmon at Olsen Creek, Prince William Sound. Alaska. U.S. Fish. Wildl. Serv. Special Sci. Rep. Fish. 483. 26 pp.
- Hoar, W. S. 1956. The behavior of migrating pink and chum salmon fry. J. Fish. Res. Board Canada 13:309-325.
- Hunter, J. G. 1959. Survival and production of pink and chum salmon in a coastal stream. J. Fish. Res. Bd. Canada 16:835-886.
- Ishida, T. 1966. Salmon of the North Pacific Ocean. Part III. Reviews of the life history of North Pacific Salmon. 2. Pink Salmon in the Far East in Int. N. Pac. Fish. Comm. Bull. 18. 29-39 pp.
- _____. 1967. Salmon of the North Pacific Ocean./Part IV. Spawning populations of North Pacific Salmon. 2. Pink Salmon of the Far East. Int. N. Pac. Fish. Comm. Bull 23:9-22.
- Kaganovskii, A. G. 1949. Some problems of the biology and changes in abundance of pink salmon. IZU. TINRO 31:3-57.
- Krokhin, E. M., and F. V. Krogus. 1937. Study of the Bolshaia River basin and its salmon spawning grounds. IZU TINRO 9:156.
- Krueger, S. W. 1981. Freshwater habitat relationships, pink salmon (Oncorhynchus gorbuscha). Alaska Dept. Fish Game, Anchorage. 41 pp.
- Kurko, K. W. 1977. Investigations on the amount of potential spawning area available to chinook, pink, and chum salmon in the upper Skagit River, Washington. M.S. Thesis, University of Washington, Seattle. 76 pp.
- Kuznetsov, I. I. 1928. Some observations on the spawning of Amur and Kamchatka salmon. IZU. TINRO, Vol. 2.
- Lister, D. B., and C. E. Walker. 1966. The effects of flow control on freshwater survival of chum, coho, and chinook salmon in the Big Qualicum River. Canadian Fish. Cult. 37: 3-21.
- McNeil, W. J. 1966. Effect of the spawning bed environment on reproduction of pink and chum salmon. U.S. Fish Wildl. Serv., Fish. Bull. 65:495-523.

- McNeil, W. J. 1968. Survival of pink and chum salmon eggs and alevins. Pages 101-117 in H. R. McMillan lectures in fisheries; symposium on salmon and trout in streams. Univ. B.C. February 1968.
- McNeil, W. J., and W. H. Ahnell. 1964. Success of pink salmon spawning relative to size of spawning bed material. U.S. Fish. Wildl. Serv. Spec. Sci. Rep. Fish. 469. 15 p.
- McNeil, W. J., and J. E. Bailey. 1975. Salmon ranchers manual. U.S. Natl. Mar. Fish. Serv. N.W. Fish. Cent. Auke Bay Fish. Lab. Rep. 95 pp.
- Milhous, R. T. 1982. Working paper on the application of the Physical Habitat Simulation System to water management: The use of the PHABSIM System for incubation-spawning analysis. Draft Report. U.S. Fish Wildl. Serv. Instream Flow and Aquatic Systems Group, Fort Collins, CO. 21 pp.
- Milhous, R. T., D. L. Wegner, and T. Waddle. 1984. User's guide to the Physical Habitat Simulation System. Instream Flow Information Paper 11. U.S. Fish Wildl. Serv., FWS/OBS-81/43. Revised.
- Nadeau, D. 1984. Unpublished field data. U.S. Fish Wildl. Serv., Ecol. Serv., Anchorage, AK.
- Neave, F. 1952. Even year and odd year pink salmon populations. Trans. Roy. Soc. Can. 46(v):55-70.
- _____. 1953. Principles affecting the size of pink and chum salmon populations in British Columbia. J. Fish. Res. Bd. Can. 9(9):450-491.
- _____. 1966. Salmon of the North Pacific Ocean. Part III. A review of the life history of North Pacific salmon. 5. Pink salmon in British Columbia. Int. N. Pac. Fish. Comm. Bull. 18:71-79.
- Nehring, R. B., and R. Anderson. 1982. Stream fisheries investigations. Job Prog. Rep. prj: F-51-R-7. Fed. Aid in Fish. Wildl. Invest., Col. Div. Wildl., Fish. Res. Sect., Ft. Collins. 185 pp.
- _____. 1983. Stream fisheries investigations. Job Prog. Rep: Proj. F-51-R-7. Fed. Aid in Fish Wildl. Invest. Col. Div. Wildl., Fish Res. Sect., Ft. Collins. 188 pp.
- Nikolskii, G. V., and S. G. Soin. 1954. On the biological basis of the salmon fishery in the Amur system. Priroda (Mosc.), No. 4, 52-58 pp.
- Petrenko, I. N. 1964. The influence of the temperature factor while rearing immature pink salmon. Rybnoe Khozyaistvo 40(2):34-37. (Trans. by S.L. Pearson. 1964. N. W. Alaska Fish. Cent. Seattle, Wash.)

- Ricker, W. E. 1962. Regulation of the abundance of pink salmon populations. Pages 155-200 in H. R. McMillan lectures in fisheries; symposium on pink salmon. Univ. of B.C.
- Scott, W. B., and E. J. Crossman. 1973. Freshwater fishes of Canada. Fish. Res. Board Can. Bull. 184, Ottawa, Canada. 966 pp.
- Semko, R. S. 1939. Kamchatka pink salmon. IZU.TINRO. 16:1-111.
- Sheridan, W. L. 1962. Relation of stream temperatures to timing of pink salmon escapements in southeast Alaska. Pages 87-102 in H. R. McMillan lectures in fisheries; symposium on pink salmon. Univ. of B.C.
- Sheridan, W. L., and W. J. McNeil. 1960. Effects of logging on the productivity of pink salmon streams in Alaska. Res. of Fish., Coll. of Fish., Fish. Res. Inst., Univ. of Wash. Contr. #70: 16-17.
- Smith, H. D. 1966. Lakelse River pink salmon. Pages 16-18 in Proceedings of N.E. Pac. Pink Salmon Workshop. Alaska Dept. of Fish and Game. Juneau.
- Tennant, D. L. 1976. Instream flow regimens for fish, wildlife, recreation, and related environmental resources. Pages 359-373 in Proc. Instream Flow Needs, Vol. II, Am. Fish. Soc. Bethesda, MD.
- Wesche, T. A.. 1980. The WRRRI trout cover rating method. Water Resour. Res. Inst. Laramie, WY. Water Resour. Ser. 78. 46 pp.
- Wickett, W. P. 1962. Environmental variability and reproduction potentials of pink salmon in British Columbia. Pages 73-86 in H. R. McMillan lectures in fisheries; symposium on pink salmon. Univ. of B.C.
- Wilson, W. J., E. W. Trihey, J. E. Baldrige, C. D. Evans, J. G. Thiele, and D. E. Trudgen. 1981. An assessment of environmental effects of construction and operation of the proposed Terror Lake hydroelectric facility, Kodiak, Alaska. Arctic Environmental Information and Data Center, Univ. of Alaska, Anchorage. 419 pp.

REPORT DOCUMENTATION PAGE	1. REPORT NO. Biological Report 82(10.109)	2.	3. Recipient's Accession No.
4. Title and Subtitle Habitat Suitability Index Models and Instream Flow Suitability Curves: Pink Salmon		5. Report Date August 1985	
7. Author(s) Robert F. Raleigh and Patrick C. Nelson		6.	
9. Performing Organization Name and Address Western Energy and Land Use Team U.S. Fish and Wildlife Service Drake Creekside Building One 2627 Redwing Road Fort Collins, CO 80526-2899		8. Performing Organization Rept. No.	
12. Sponsoring Organization Name and Address Western Energy and Land Use Team Division of Biological Services Research and Development Fish and Wildlife Service Department of the Interior, Washington, DC 20240		10. Project/Task/Work Unit No.	
15. Supplementary Notes The Biological Report series was initiated in October 1984 to replace the FWS/OBS Series published since 1976. The report number assigned to this model follows consecutively from the Habitat Suitability Index models published as FWS/OBS-82/10., now numbered as Biological Report 82(10.).		11. Contract(C) or Grant(G) No. (C) (G)	
16. Abstract (Limit: 200 words) A review and synthesis of existing information were used to develop a Habitat Suitability Index (HSI) model and instream flow suitability curves for pink salmon (<i>Oncorhynchus gorbuscha</i>). The model consolidates habitat use information into a framework appropriate for field application, and is scaled to produce an index between 0.0 (unsuitable habitat) and 1.0 (optimum habitat). HSI models are designed to be used with Habitat Evaluation Procedures previously developed by the U.S. Fish and Wildlife Service.		13. Type of Report & Period Covered	
17. Document Analysis a. Descriptors Fishes Salmon Habitability Mathematical models b. Identifiers/Open-Ended Terms Pink Salmon <i>Oncorhynchus gorbuscha</i> Habitat suitability c. COSATI Field/Group		14.	
18. Availability Statement None unlimited	19. Security Class (This Report) Unclassified	21. No. of Pages 36	
	20. Security Class (This Page) Unclassified	22. Price	