

- NOTE:**
1. Dimensions not labeled are in millimeters.
 2. Dimensional tolerances not shown or implied are intended to be those consistent with the proper functioning of the part, including its appearance, and accepted manufacturing practices.
 3. The use of terminal section, Type CRT, is limited to driveways, road approaches and low speed minor road connections. Do not use on mainline roadways.
 4. Do not bolt post to W beam for 2.6 m radius only.
 5. Furnish hardware in the metric sizes shown. Equivalent imperial sizes may be used when metric sizes are not available.

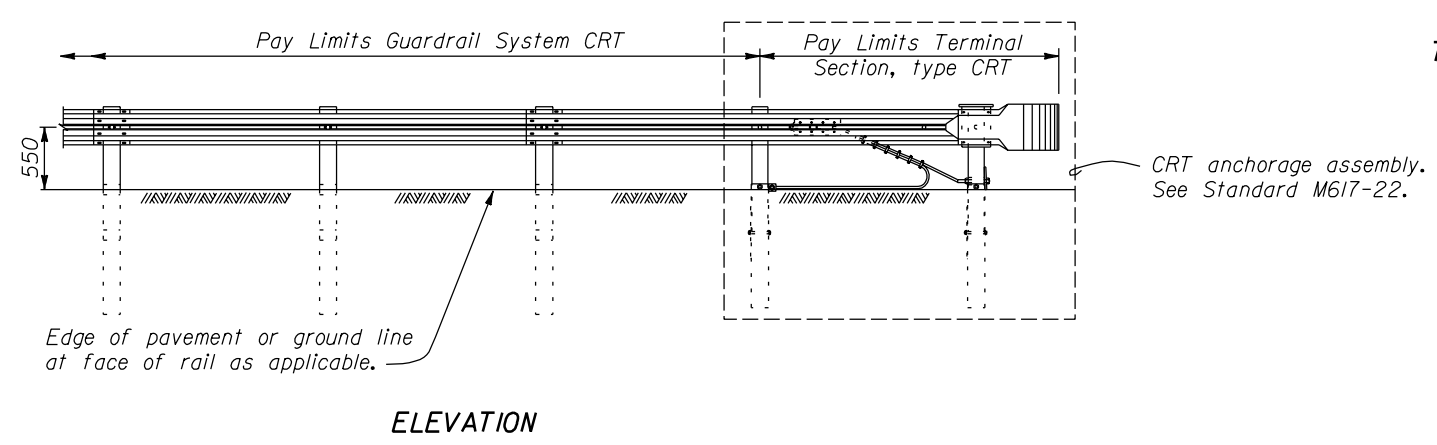
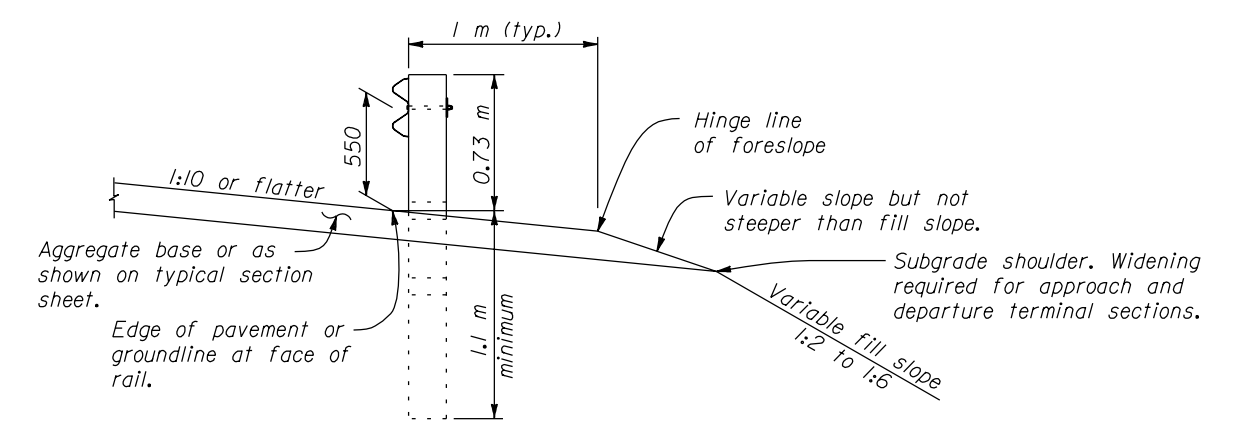

GUARDRAIL SYSTEM CRT WITH CABLE RELEASING TERMINAL CRT POSTS

U.S. DEPARTMENT OF TRANSPORTATION
 FEDERAL HIGHWAY ADMINISTRATION
 FEDERAL LANDS HIGHWAY

METRIC STANDARD
CRT W BEAM GUARDRAIL
CABLE RELEASING TERMINAL
CRT POSTS
TERMINAL SECTION, TYPE CRT

STANDARD APPROVED FOR USE 3/1996
 REVISED: 12/1998

STANDARD
M617-21

NO SCALE

22 NOV 2000 f:\standrow\metric\mst61721.dgn