

ELEVATION

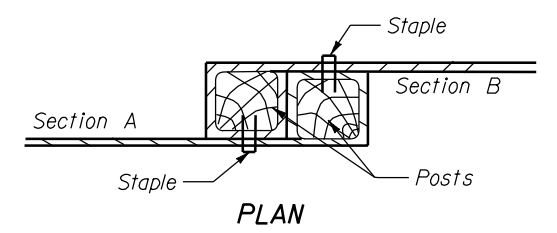

PLAN

JOINING TWO ADJACENT SILT FENCE SECTIONS

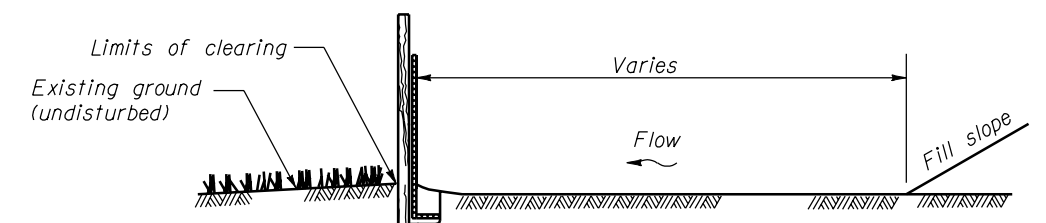

ELEVATION

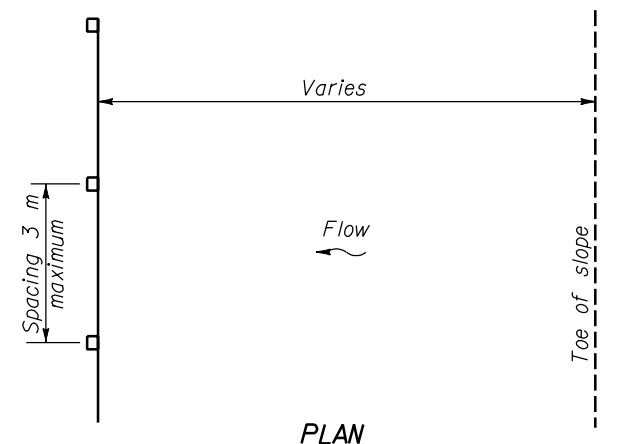

PLAN

SILT FENCE INSTALLATION AT TOE OF FILL

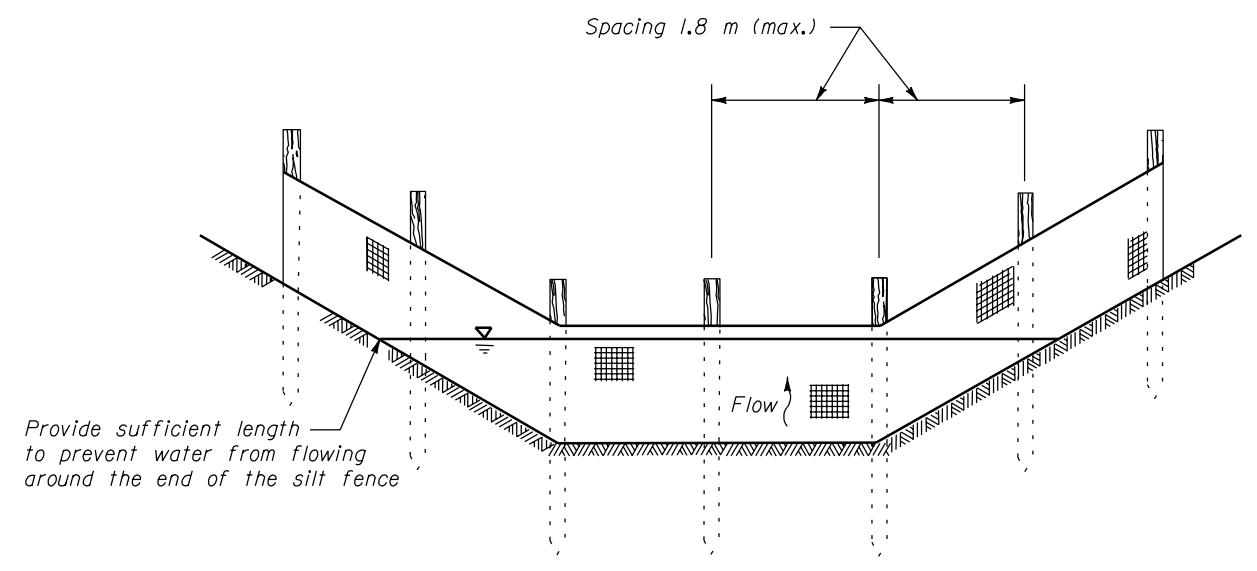

SILT FENCE INSTALLATION IN A DRAINAGE DITCH

(See note 2)

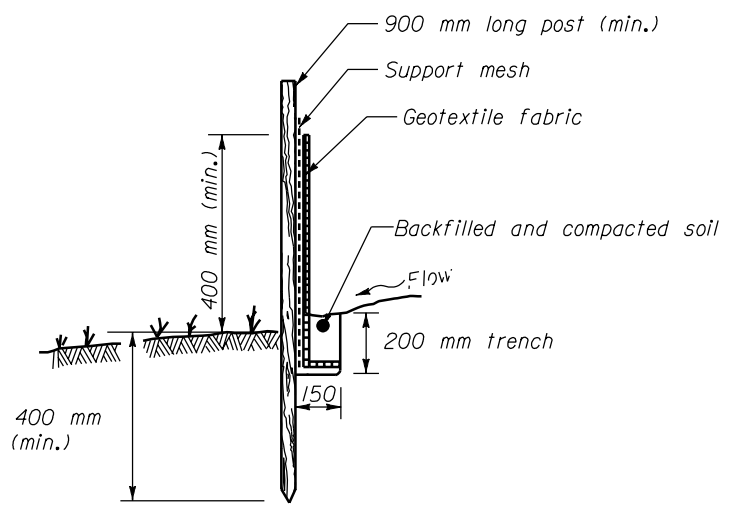

POST AND FABRIC INSTALLATION DETAIL

NOTE:

1. Dimensions not labeled are in millimeters.
2. Use drainage ditch installation for low flow conditions only when specified on Erosion Control Plan.
3. Alternate pre-assembled silt fence options will be allowed as long as specified dimensions are satisfied. Follow manufacturer's information for installation procedures.

NO SCALE

U.S. DEPARTMENT OF TRANSPORTATION FEDERAL HIGHWAY ADMINISTRATION FEDERAL LANDS HIGHWAY	
METRIC STANDARD	
SILT FENCE	
STANDARD APPROVED FOR USE 3/1996	STANDARD
REVISED: 6/1997	M157-1

16 NOV 2000  
f:\standrow\metric\msh5101.dgn