

**SEDIMENT TRAP (TYPE A) RIPRAP OUTLET**

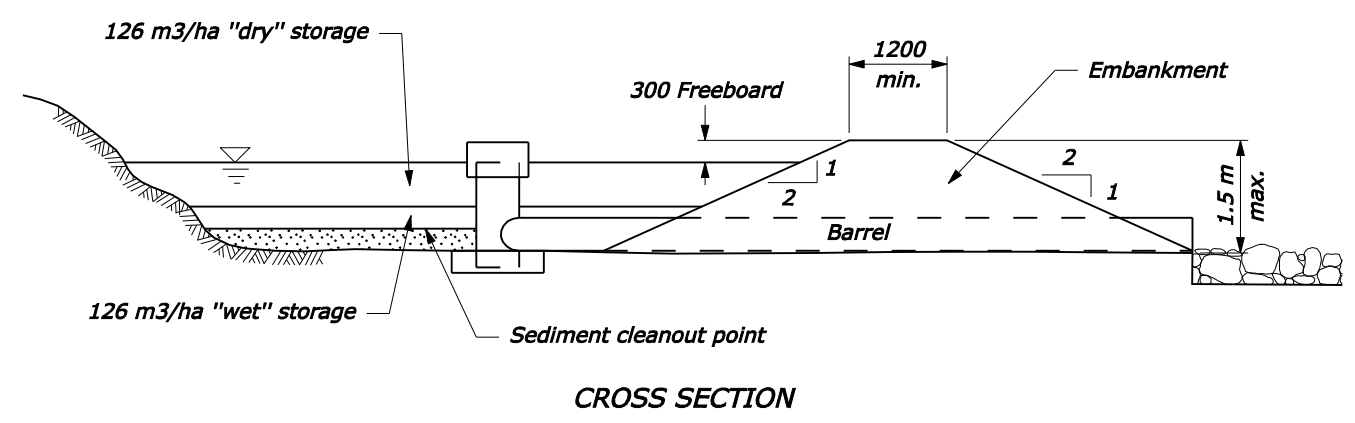

**SEDIMENT TRAP (TYPE B) PIPE OUTLET**

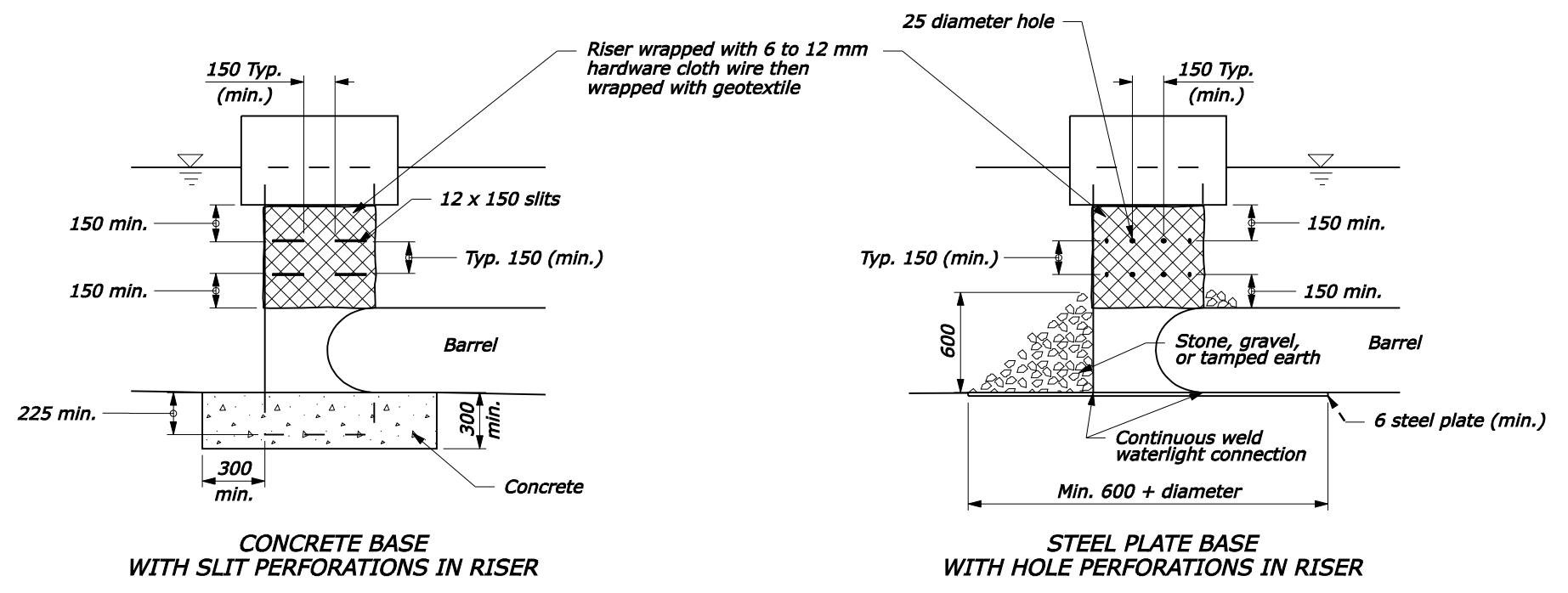

**NOTE:**

1. Clear, grub, and remove all vegetative matter including root mat before constructing Sediment Trap.
2. Remove vegetative matter, other organic material, and large stones from embankment fill material.
3. Compact embankment in 200 mm layers using construction equipment for compaction of each layer.
4. Seed the soil embankment and all cut slopes with temporary or permanent vegetation within 7 days of construction.
5. Remove sediment from Sediment Trap when accumulated sediment reaches half the design water storage of the trap.
6. Inspect Sediment Trap regularly for damage and accumulated sediment and especially after each storm event. Make repairs as required.
7. Remove the Sediment Trap and stabilize the location by grading and seeding when the upslope drainage area has been stabilized against erosion.
8. Do not use sediment traps for drainage areas over 2 hectares.
9. Dimensions without units are millimeters.

U.S. DEPARTMENT OF TRANSPORTATION  
 FEDERAL HIGHWAY ADMINISTRATION  
 FEDERAL LANDS HIGHWAY  
 METRIC STANDARD

**SEDIMENT TRAP**

STANDARD APPROVED FOR USE 6/2005  
 REVISED:

STANDARD  
**M157-4**

NO SCALE

06-Oct-2005 08:28 AM F:\StandDraw\st15704.dgn [Metric]