



TAX EXEMPT BONDS



FY 2007

TAX EXEMPT BONDS

WORK PLAN

Planning Guidelines

Executive Summary

Tax Exempt Bonds

FY 2007 Implementing Guidelines

The work plan provides program guidance and direction to all TEB employees.

TEB Operating Priorities support the IRS's Strategic Plan for FY 2005-2009, TE/GE ConOPs and TE/GE Strategy and Program Plan for FY 2007-2008. The IRS Strategic Plan outlines three strategic goals that guide the future direction of the agency.

- Improve Taxpayer Service;
- Enhance Enforcement of the Tax Law; and
- Modernize the IRS through its People, Processes and Technology.

In support of these goals, TEB has committed to the following Operating Priorities:

- Maintain increased enforcement actions against high-risk cases and abusive tax schemes;
- Detect and deter abusive tax shelters through education and examination strategies;
- Refine compliance risk assessments/market-segment analyses; and
- Address the use of derivatives to divert rebatable arbitrage.

Section I provides the specific program priorities and goals/objectives for the Customer Education & Outreach function.

Section II provides the specific program priorities and goals/objectives for TEB Compliance Services.

Operating Priorities

Field Operations (FO) will continue its focus on questionable bond transactions, concentrating on efforts directed toward abusive transactions and their promoters. It is expected that, similar to FY 2006, TEB will spend additional resources to increase activities relating to arbitrage motivated and/or abusive transactions with a continuing focus on abuses involving swaps and other derivative contracts. FO will continue to utilize the IRC section 6700 tax promoter penalty, to target the promoters of abusive transactions and the lack of diligence by market professionals. TEB will make referrals of professionals to the Office of Professional Responsibility (OPR), Criminal Investigation (CI) and other agencies when appropriate.

Field Operations will continue to focus on implementing market segment examination initiatives such as the charitable financing initiative initiated in the last quarter of FY 2006. The charitable financing initiative has been designed to provide for the selection of an additional sample of charitable financings for examination in FY 2007.

TEB's Arbitrage Team will continue to implement discrete compliance initiatives directed toward measuring and encouraging compliance with the arbitrage regulations. The swap initiative commenced in the third quarter of FY 2006 has been designed to include a second sample selection in FY 2007 if appropriate. TEB plans to initiate several additional discrete arbitrage initiatives directed toward reviewing such items as late arbitrage payments, yield reduction payments, and substantial qualified administrative costs.

Compliance and Program Management (CPM) will continue with its primary responsibility of negotiating and executing voluntary closing agreements pursuant to the Tax Exempt Bond Voluntary Closing Agreement Program (TEB VCAP).

A high priority of TEB is to communicate effectively with the diverse membership of the municipal bond community. TEB will continue to develop partnerships with state and local government officials, regulatory agencies, industry, and national professional associations, as well as their state and local affiliates and members within each of our customer segments.

TEB will continue to train its workforce to ensure that employees have the skills necessary to execute TEB's operating priorities. TEB intends to continue to build out its specialty training programs to allow employees to focus on specialized areas of tax-exempt financing. TEB will continue its use of the employee survey to identify opportunities for improvements in employee satisfaction.

FY 2006 Accomplishments

TEB leadership is grateful for the support and business results of its highly skilled workforce. During FY 2006, TEB met or exceeded its performance goals related to examination closures, closures of voluntary closing agreement requests, and outreach participants reached. Examination cycle time was also reduced. Interaction with OPR and CI continued to increase. TEB also strengthened its relationship with various members of its customer segment in FY 2006 by implementing an annual TEB Workplan Press Conference and a TEB Media Policy. TEB also participated in two nationwide teleconferences sponsored by the National Association of Bond Lawyers (NABL).

As reflected in TEB's Survey 2006 results, TEB's overall employee satisfaction also remained high. TEB leadership is appreciative of the satisfaction TEB employees take in their work.

SECTION I

Customer Education and Outreach

Overview of Customer Education and Outreach

TEB will focus on providing the participants in the municipal bond industry with quality service. TEB will assist participants in understanding their tax responsibilities by conducting tailored educational programs. TEB will also monitor non-compliance trends for the purpose of designing proactive education and outreach products for use by TEB customers.

Each TEB office will plan to fully support opportunities for education and outreach to customers in the various bond industry segments with a focus on assistance to professionals who provide tax advice or monitor post-issuance use or arbitrage compliance. Managers and their employees will participate in workshops, seminars, and meetings sponsored by bond industry groups and associations to effectively leverage limited TEB resources. These outreach efforts will focus on educating customers with respect to the federal tax requirements that must be met throughout the life cycle of municipal bonds in order to maintain the tax-exempt status of interest income of the bonds.

Compliance and Program Management

The TEB CPM staff is responsible for:

- Improving and expanding TEB's voluntary compliance programs;
- Enhancing education and outreach programs with external stakeholders;
- Developing and issuing, as needed, specialized educational materials and publications;
- Expanding the TEB Internet and Intranet sites and otherwise leveraging technology to meet customer and FO needs;
- Identifying and assisting in the implementation of special projects;
- Developing and evaluating market segment project initiatives to determine compliance levels and to identify emerging trends and issues;
- Developing, implementing and evaluating arbitrage compliance initiatives;
- Classifying returns related to general examination program activity;
- Coordinating with Customer Account Services (CAS) return filings, taxpayer inquiries, revisions to Form 8038 series returns, and training sessions for CAS personnel;
- Providing assistance, when requested, to the Director's staff and FO on administrative and technical matters;
- Coordinating legislative proposals with internal and external offices and agencies with a primary goal of increasing overall community compliance levels; and

- Working with the Office of Chief Counsel and the Department of Treasury on published guidance projects, with a primary goal of improving tax administration.

Field Operations

TEB FO will continue to assist CPM in the development and delivery of targeted outreach programs by participation in seminars/meetings and partnering with outside stakeholders. FO will also assist CPM in identifying areas of abuse and noncompliance warranting the development of market segment initiatives and arbitrage initiatives.

Focus Group

FO and CPM employees will continue to participate in the TEB Focus Group. The TEB Focus Group facilitates quality examinations and ensures that examinations are conducted in a timely and efficient manner and result in consistent treatment of issues raised nationwide. The Focus Group includes agent and manager representatives from the FO groups, CPM representatives, and representatives from Counsel and Appeals. The TEB Focus Group holds quarterly meetings and plans to conduct at least one visit with each FO group and CPM during FY 2007.

Performance Measures for CE&O

The following performance indicators will be used in FY 07:

Tax Exempt Bonds	FY 2006 Goal	FY 2007 Goal
Number of Outreach Events	40	40
Customer Reached	4,000	5,000

SECTION II

Compliance Services

Operating Priorities

The Operating Priorities included in the FY 2007 TE/GE Strategy and Program Plan for FY 2007-2008 were included in both the GE Program Plan and the TEB Program Plan and used in formulating the TEB FY 2007 Work Plan are:

- Maintain increased enforcement actions against high-risk cases and abusive tax schemes;
- Detect and deter abusive tax shelters through education and examination strategies;
- Refine compliance risk assessments/market-segment; and
- Address the use of derivatives to divert rebatable arbitrage.

Overview of Compliance Services

TEB will focus on identifying and correcting noncompliance, ensuring consistency and fairness in application of law, and resolving issues at the lowest possible level using appropriate resolution mechanisms.

TEB Field Operations is responsible for:

- Conducting examinations using standardized procedures and audit guidelines;
- Measuring the compliance levels of market segments by conducting project initiatives and identifying emerging trends;
- Applying IRC section 6700 promoter penalties, where appropriate;
- Coordinating with other business operating divisions to apply tax to bondholders and conduit borrowers, where appropriate;
- Identifying best practices and recommending changes in procedures;
- Coordinating with, and referring appropriate cases to, other IRS functions, including OPR and CI; and
- Establishing returns on the Audit Information Management System (AIMS).

TEB Compliance and Program Management staff is responsible for:

- Coordinating referral information with the TEB Referral Committee;
- Working VCAP submissions;
- Working willful neglect determinations on late-filed returns;
- Coordinating arbitrage work through the Arbitrage Team;
- Closing examination cases on AIMS;
- Conducting mandatory review (technical advice requests and cases being forwarded to Appeals);
- Maintaining and updating the third party contact database; and

- Assisting field personnel in the identification and development of complex and emerging technical issues.

For FY 2007, the greatest emphasis will continue to be placed on emerging areas of concern and continuing investigations into arbitrage motivated and/or abusive transactions. It is anticipated that examination FTE applied to arbitrage motivated and/or abusive transactions will continue to increase in FY 2007 and that the greatest increase will be related to the use of swaps and other derivative contracts to divert rebatable arbitrage. Training activities will be conducted, as necessary, to ensure consistent and uniform issue development and resolution.

In FY 2007, TEB will continue to focus on abusive and arbitrage-driven transactions involving long investment periods or large investment amounts, including pooled financing cases, cases involving forward floats, escrow puts and other devices use to burn yield in advance refunding issuances, cases involving the use of derivatives to burn yield, including swaps, strips and swaptions, and the overissuance of tax and revenue anticipation notes (TRANS). The issuance of bonds for the primary purpose of diverting rebatable arbitrage remains TEB's highest compliance risk and enforcement focus. Managers will assign these transactions priority status and ensure all appropriate penalties and sanctions are applied.

The FY 2007 program goals include a renewed focus toward improving post-issuance compliance with the use and payment restrictions found in IRC 141. The first stage in this program, initiated during FY 2006, was a charitable financing examination project consisting of approximately 30 limited-scope examinations of charitable financings. The first stage of the initiative was directed at measuring compliance in the area of charitable health care and housing financings. This stage of the initiative will be completed during FY 2007.

The initiative will be expanded in FY 2007 to include a broader survey of different types of charitable financings. TEB is coordinating this stage of the initiative with the Exempt Organizations Compliance Unit. TEB expects that it will review a much larger sample of IRC 501(c)(3) financings during this stage of the initiative.

The Arbitrage Team will survey Forms 8038-T for potential areas of noncompliance and possible classification. Issuers who file on incorrect, outdated forms will be contacted, as necessary, to properly complete the updated form. As part of this review, rebate calculations will typically be requested and reviewed. The Arbitrage Team will transfer to FO all rebate cases in which FO assistance is needed for further investigation or adjustment.

The Arbitrage Team will review Forms 8038-R requesting refund of arbitrage rebate and determine whether the request can be surveyed or requires further investigation. All requests requiring further development will be assigned to a revenue agent on the Arbitrage Team for processing.

CPM will perform compliance checks on late filed bond returns forwarded by the Ogden Service Center. CPM will make determinations regarding whether the failure to file timely is due to willful neglect by following the procedures set forth in Rev. Proc. 2002-48, 2002-37 I.R.B. 531, or Rev. Proc. 2005-40, 2005-28 I.R.B. 83. CPM will, when necessary, contact the issuer for an explanation. CPM will transfer to FO all late-filing cases in which FO assistance is needed for further investigation.

FY 2007 Audit Procedures

The audit techniques for conducting examination activities are field, office, and correspondence. Generally, the managers in FO are responsible for determining which audit technique is appropriate for a case based on the potential issues involved, the scope of the examination, and the most effective way to gather required information.

Managers will determine when the collection of bondholder names becomes a priority for an ongoing examination. Managers should keep in mind the often long periods of time involved in the collection process and the higher likelihood of bondholder taxation due to increases in sanction amounts. Managers are expected to verify the bondholder identification process has been initiated by the field agent no later than the date a proposed adverse determination is issued.

FO managers will coordinate with other business operating divisions all potential adjustments to the borrower's tax return, including adjustments under IRC sections 150(b) and 168(g). FO managers should coordinate early in the examination process in order to preserve potential adjustments for expiring tax years.

Examination Categories

For FY 2007, TEB resources will be allocated to the following specialty areas:

- Solid Waste Disposal Facilities
- Yield Burning
- Failure to Rollover Escrowed Securities to Zero Interest Rate State and Local Government Securities
- Loan Pools
- Tax and Revenue Anticipation Notes
- Indian Tribal Governments
- Tax Promoter Penalties (Section 6700)
- Section 501(c)(3) Charities
- Single Family Housing
- Multi-Family Housing
- Stadiums

These examination areas and other examination categories will be separately identified for technical time and inventory tracking reporting purposes through particular Activity Codes for the type of return and specific Project Codes.

Research Program

The TEB market segmentation is a systematic method to define the universe by conducting examinations of a sample of returns on a nationwide or geographic basis and reflecting results/conclusions from the samples in a profile of the applicable market segment. The objective of TEB market segmentation is to continually build information and knowledge through conducting research on the compliance levels of various types of bond issuances. These research projects assist in the targeting of direct compliance activities to areas of actual or suspected noncompliance.

Annually, the Director, TEB will conduct a meeting of the CPM Manager and the FO Manager to develop the subsequent fiscal year market segment project initiatives. Consideration will be given to identifying the proposed TEB samples, reviewing open samples scheduled for completion and the results and findings from completed samples.

Voluntary Resolution Programs

CPM will work documents submitted as part of the tax-exempt bond voluntary closing agreement program (VCAP) (Notice 2001-60, 2001-40 I.R.B. 304) and other voluntary resolution programs (e.g., Rev. Proc. 97-15, 1997-1 C.B. 635). CPM will work with other responsible offices to develop and expand its voluntary compliance programs and procedures. FO will work with CPM to direct wide-spread, non-abusive cases to the voluntary program through timely announcements of proposed audit initiatives.

Compliance Support Function

The TEB CPM staff provides administrative and research support to the field compliance function. This support includes AIMS activities, referral analysis and research, claims processing, and third-party contact data. The CPM staff also will research available database information to provide field agents supporting documentation and information regarding examinations. See attachment.

Performance Measures for Compliance Services

The following performance indicators will be used in FY 07:

Tax Exempt Bonds	FY 2006 Goal	FY 2007 Goal
Voluntary Closing Agreement Cases Closed	60	65
Examination Closed	480	500
Examination Timeliness	340	310
Examination Quality	83%	88%

ATTACHMENT I

TEB TRAINING COURSES

The following items are descriptions of TEB training courses:

RESEARCH TRAINING

Course 4237: RICS – Phase I

This training is a 5-day course (including training and travel time) based on the RICS Phase I Training Guide that covers RICS functionality for basic RICS users. The primary purpose of the training is to support the classification of TE/GE returns and TE/GE non-return units. This training is ideal for new TE/GE classifiers and other new RICS users.

Course 4256: RICS – Phase II

This training is a 5-day course (including training and travel time) based on the RICS Phase II Training Guide that covers RICS functionality for experienced RICS users. This training is for all experienced RICS users.

Course 5108: Introduction to Specialized Research Software

This training will teach participants how to use electronic software of a commercial tax service to research tax law, court cases, revenue rulings, finance industry publications, municipal bond information, and other tax related materials. The training provides advanced instruction and function-specific exercises.

TEB TECHNICAL TRAINING

Course 4207a: Discrepancy Adjustments

This training provides agents with the basic knowledge and skills necessary to propose discrepancy adjustments to taxpayers Forms 1040 and 1120 as a result of a TEB examination. This course is one week in length. Training will be scheduled for new agents to TEB as needed in FY 2007.

Course 4232: Basic Tax Exempt Bond Training – Phase I

This training provides agents with the basic knowledge and skills necessary to conduct examinations of municipal financing arrangements. This course is three weeks in length. Training is scheduled for new agents to TEB in the third quarter of FY 2007.

Course 4259a: Advanced Tax Exempt Bond Training – Phase II

This training provides agents with the advanced knowledge and skills necessary to conduct examinations of municipal financing arrangements. Topics include advance yield on bonds, yield on investments, allocation and accounting, reimbursements and refundings. This course is two weeks in length. Training is scheduled for new agents to TEB in the fourth quarter of FY 2007.

Course 4259b: Advanced Tax Exempt Bond Training – Phase III

This training provides agents with more advanced knowledge and skills to conduct examinations of municipal financing arrangements. Topics include pooled financings, advanced arbitrage and rebate concepts with respect to hedge bonds, reissuances, advance refundings and financial products. This course is one week in length. Training is scheduled for new agents to TEB in the fourth quarter of FY 2007.

Course 4233: TEB Technical Field Conference (CPE)

This training will cover current technical and operational developments in the bond area. There will be discussions of significant issues under examination and techniques used to develop the issues. Training will be conducted in the third quarter. The length of training is 5 course days (including training and travel time). The targeted audience is all TEB Technical Employees.

Course 9682b: Improving Performance thru Data Driven Decision Making

This training will introduce a nine-step problem-solving model. Participants use a current business challenge to analyze and solve problems. This course is one week in length.

TEB SPECIAL EMPHASIS TRAINING**Course: Charitable Financings Bond Project Initiative**

This training provides agents assigned IRC section 501(c)(3) bond cases and the managers responsible for the initiative with the knowledge of the structure and requirements related to charitable financings. The course will consist of a review of assigned cases and discussion of techniques to develop the related issues. The training will be 24 hours.

Course: Swap Initiative

This training provides Arbitrage Team members and agents assigned swap initiative cases and the manager responsible for the initiative with a knowledge of the issues and requirements related to swaps. The course will consist of a review of assigned cases and discussion of techniques to further develop the related issues. The training will be 24 hours.

Course: Rebate

This course will provide agents training in the use of Excel spreadsheets with respect to calculating arbitrage rebate, including computing investment yield, valuing investments, and computing the rebate amount and yield reduction payments. The training will be 24 hours and be taught as part of a group meeting.

Course: Abusive Transactions Update

This course provides agents with training regarding the development of examinations of potentially abusive transactions. The course will provide an update on recent developments in abusive transactions. The training will be 24 hours.

Course: TEB Compliance Overview

This course provides non-TEB personnel an update of TEB compliance activities and how TEB issues interact with other functions in TE/GE. The training will be 8 hours and will be offered when requested by other functions in TE/GE.

Course: TEB Technical Update

This course provides an update on technical issues in TEB to Service Center and Call Site personnel. The training highlights emerging issues in TEB and provides information to personnel dealing with pre-filing and post filing compliance.

REPORT GENERATION SOFTWARE (RGS) TRAINING**Course 4207a: EP/EO RGS (NT) Discrepancy Adjustments Training – Full**

This training will cover the technical and procedural aspects of discrepancy adjustments as well as the RGS training on using the new windows version of RGS software to perform discrepancy adjustments. The targeted audience and date to be held will be locally determined. The length of the training is 4 days (including training and travel time).

Course 4248: RGS Coordinators Training

This training provides the TEB Division RGS Coordinator with information concerning their responsibilities as division coordinator. One person from OPR or one from FO will attend this 16 hours course (including training and travel time).

TE/GE REPORTING AND ELECTRONIC EXAMINATION SYSTEM (TREES)**Course: TREES**

This training provides an overview and hands on training on the use of TREES. The course will be offered as part of the rollout of the TREES system. The course will be 24 hours.

ATTACHMENT II

Workload Selection

TEB will continue to refine the workload selection criteria utilized in prior years. Workload selection will be monitored to ensure that key areas identified through project initiatives, market segment risk assessment and focus groups are addressed, and that the actions being assigned represent the optimal approach to the identified issue. The Workload Selection Process described in this section will be a primary tool TEB uses to identify and prioritize workload in concert with its Annual Work Plan.

An effective Workload Selection Process should accomplish several key tasks. It should:

1. Generate work that addresses issues pertaining to non-compliance on a national level.
2. Be data driven, to the fullest extent possible.
3. Be consistent with TEB's balanced measures.
4. Ensure fair treatment of each taxpayer.
5. Ensure adequate controls are in place in accordance with Servicewide work assignment and approval requirements.
6. Be flexible enough to accommodate Work Plan adjustments, e.g., new legislation and court decisions.
7. Provide the TEB field group managers the flexibility they need to balance local concerns with national priorities.

The Workload Selection Process for FY 2007 incorporates information from several sources. All of these sources are necessary to ensure the Workload Selection Process is data driven, consistent with our balanced measures and reflective of our customers' needs. This approach will also ensure that TEB efficiently uses its enforcement resources. TEB products that have a direct impact on this Workload Selection Process include:

1. TEB Compliance/Project Initiatives
2. TEB Market Segment Risk Assessment
3. FY 2007 Annual Workplan
4. TEB Balanced Measures
5. Findings from focus groups, other ad-hoc meetings and other customer communicated items that identify customer needs.

Compliance/ Project Initiatives

There are two primary methodologies used to initiate project initiative. They are:

1. Market Segment Compliance Measurement – This methodology includes the systemic selection of each market segment over a period of time to measure

noncompliance of that segment or type of bond. For example, small issue manufacturing bonds and single family housing bonds would constitute separate market segments.

2. Emerging Issues – This methodology measures noncompliance by identifying cases based on the existence of a potential emerging or identified issues within the TEB return population.

The annual Market Segment Risk Assessment report provides a description of the types of bond issues for which returns have been filed during a specific year prior to the work plan year. The bond returns are categorized by the type of bond issue. Each category or segment is assigned a compliance risk factor (high, medium or low). The comparison of the volume (number of returns filed and dollar amount of the total issues in a segment) from one year to the next can impact the risk factor assigned to the segment.

The FY 2007 Annual Work Plan will impact the Workload Selection Process in that it will typically quantify the amount of resources that will be expended on any given market segment. For example, the number of examinations is dependent upon the resources devoted to these various segments. Resource allocation decisions are made by the Director of TEB and will be consistent with the overall goals of the business plan.

The Balanced Measures are consistent with the overall outline of the IRS organizational measures:

- Employee Satisfaction
- Customer Satisfaction
- Business – Results – Quality & Quantity

These three measures represent one of the levers of change for the successful modernization of the Internal Revenue Service. The actions undertaken in the Workload Selection Process will be consistent with these measures.

The purpose of this Workload Selection Process is to outline the methodology used to identify and prioritize those returns or customers that warrant an examination. It will also identify and prioritize those customers who may be less compliant on a given national issue. The FY 2007 Annual Work Plan quantifies resource expenditures dedicated to the various initiatives.

This Workload Selection Process does not affect the ability of a group manager to request approval of compliance matters based on their knowledge of an issue that they believe requires immediate action. However, such requests must be directed to the Manager, CPM and approved by the Manager, CPM and must be justified as to their importance as well as any negative impact on other work.

Methodology

The Workload Selection Process for FY 2007 will generate examination work for the five TEB field groups. Much of the casework will be derived from recommendations and potential compliance issues identified in Compliance/Project Initiatives, the Market Segment Risk Assessment (see Attachment VIII) and Referrals (including I.R.C. section 6700 leads).

The following areas will be emphasized in the FY 2007 Workload Selection Plan:

Claims

All claims for refund filed through the Ogden Service Center are controlled on AIMS and forwarded for processing. Some claims require taxpayer contact and others can be closed based on the information provided with the claim. The Arbitrage Team Leader will submit closed claim case files to the CPM AIMS unit for closing. If the claim is allowed, CPM will forward the Manual Refund form for the case to Ogden for issuance of the refund. CPM will close the case on AIMS.

Claim cases remain priority cases.

Referrals/Information Items

TEB referrals come from many sources: the media, informants, other Operating Divisions, Appeals, etc. All TEB referrals and information items that are submitted for examination consideration, except certain IRC 6700 cases resulting from a lead, are routed to CPM for review and approval. CPM personnel research information items on IDRS and RICS to provide relevant return filing information for the subject of the referral and information item.

To ensure unbiased selection of cases for examination, referrals must be approved by both the Manager, CPM and the Manager, FO or their representatives (the Referral Committee) before assignment to a field group.

Three forms are prepared for each Referral: a TEB Referral, Information Reports and Information Items Record and a Tax-Exempt Bond Information Item Tracking Sheet. These forms become part of the examination case file. In addition, a copy of each form is retained in a Referral Log in CPM. The group manager completes the form during the case closing and a copy of the form is pulled during the closing of the case in CPM and associated with the copy in the Referral Log. The examination results are notated in the Log. The Logs are housed in CPM and provide a historical reference record of referred bond issues.

Promoter Penalty Cases

IRC section 6700 of the Code imposes a penalty on any “person” who commits certain actions described in the Code section. TEB identifies IRC section 6700 leads by:

- a. Working cooperatively and coordinating, to the extent permitted under IRC section 6103, with counterparts at the Securities and Exchange Commission (SEC); National Association of Securities Dealers (NASD); Municipal Securities Rulemaking board (MSRB); and, Offices of State auditors, etc.
- b. Reviewing, as part of its normal examination activities, the use, expenditure and investment of proceeds of the bond issue and what the various participants knew, or should have known, with regard to such use, expenditure or investment of bond proceeds. In those instances where abusive transactions are found, TEB will use existing databases or John Doe summonses to determine whether there are similar transactions done by the same parties.
- c. Monitoring industry materials and publications to identify new financial techniques and schemes.

TEB has taken steps to improve identification of promoters by recommending legislative changes needed to permit TEB and SEC, NASD, MSRB and state authorities to exchange information similar to the exchange of information between IRS and Department of Labor on examinations of employee plans. Currently, TEB must seek permission (execution of Form 8821) of local officials involved in the municipal bond issuance to share information with the municipal regulatory office of the SEC if the matter is non-criminal in nature.

Group managers will assign IRC section 6700 cases priority status and ensure that penalties are applied when appropriate. TEB will use administrative tools, formal guidance and other issue resolution strategies to aggressively combat abusive transactions.

ATTACHMENT III

Market Segment Risk Assessment

Risk Assessment analysis supports TEB's continuing effort toward completion of existing project initiatives and development and implementation of additional project initiatives. The assessment process also prioritizes potential areas on noncompliance. The initial TEB risk assessment analysis relying on Statistics of Income (SOI) data for tax year 1987 – 1995 was useful and revalidated. For FY 2007, the data is taken from 2000. Each type of bond issue is considered as a separate market segment and assigned a rating potential for noncompliance of low, medium and high risk. Future examination activities will be based on this analysis as well as staffing, available guidelines and other relevant factors. For FY 2007, field personnel will be applied in such a manner as to ensure timely completion of existing projects and prompt action on a new charitable financings initiative and other emerging issues. In addition, TEB may initiate other new compliance initiatives after taking into account TEB's increased activities relating to arbitrage motivated and/or abusive transaction.

The Tax Exempt Bond (TEB) function has broadly identified its bond population and either governmental or private activity bonds. Governmental and private activity bonds have been further classified as either new long and short term bonds issues, or as refunding issues. Bond issuers are required to file information returns (Form 8038, 8038-G, 8038-GC) to provide identifying information about issued bonds. Forms 8038 and 8038-G include line items titled "Type of Issue" in which the bond issuer is required to identify the purpose of purposes for which the proceeds of the bond issue are expected to be used. TEB considers each type of bond issue as a separate market segment.

The Statistics of Income (SOI) function extracts data from these returns and provides a compilation (in the form of tables) of the data to OPR. TEB substantially relies on SOI data in its compliance risk analysis.

ASSESSMENT OF COMPLIANCE RISKS BY MARKET SEGMENT

Summary

TEB has defined noncompliance as the improper use of the economic benefit provided by tax exempt bonds. Cases of noncompliance have been developed through referrals from internal IRS offices, other federal agencies, information or media sources, information gathering and compliance initiatives and regular classification of returns. TEB has made an estimate in terms of low, medium or high potential for noncompliance for the types of bond issues.

Governmental Bonds

Governmental bonds are generally considered low risk. However, governmental educational bonds issued to finance public school construction expenditures were determined to have a medium risk of noncompliance due to the special arbitrage rebate exception for such bonds and prior examination findings. Tax and revenue anticipation notes (TRANS) and bond anticipation notes (BANS) have also been labeled as medium risk due to ongoing examination activities that have concluded that the notes have been oversized in multiple cases for arbitrage purposes. Hospital/Healthcare bonds have been labeled as medium risk due to increased indications of noncompliance related to financings impacted by hospital mergers and privatization. Lastly, the compliance risk for advance refunding issues has been labeled as high risk due to continuing concerns relating to yield burning and the use of escrow puts, forwards, hedges, and other derivative instruments to earn and divert illegal arbitrage.

Private Activity Bonds

As a whole, the potential for noncompliance for private activity bonds is somewhat greater than that for governmental bonds due to the presence of private borrowers and more complicated rules and regulations. Under the private activity bond category, the solid waste disposal, small issue and qualified 501(c)(3) bonds have been determined to have a high risk of noncompliance. Single family mortgage and multi-family housing bonds have been labeled as medium risk.

➤ High Risk:

Solid Waste: Solid waste issues were rated high based on the results of solid waste cases associated with a compliance initiative. Based on current examination activity, there are indications that the industry has broadly misinterpreted the regulations applicable to solid waste bonds.

Small Issue: A prior compliance initiative directed toward small issue bonds determined that noncompliance is relatively high in this sector. Subsequent examinations continue to reflect a relatively high level of noncompliance. Therefore, the risk level will remain high.

501(c)(3): This category of bonds has been determined to have a high risk of noncompliance due to the size of the category, the low level of TEB VCAP requests relating to post-issuance compliance, and information gathered through outreach efforts. Revenue agents have been trained in this segment and an initiative was commenced in FY 2006. Initial feedback regarding the initiative cases suggests potential problems related to inadequate record retention.

➤ Medium Risk

Single family mortgage, multi-family housing, airport, sewage, and student loan and hospital/healthcare bonds have been determined to have a medium level of risk of noncompliance.

Housing: Housing bonds, which may be issued to finance single family homes or multi-family housing projects, are determined to have a medium risk of noncompliance. With respect to single family mortgage financings, the risk level has been reduced from prior years after the completion of guidance resolving a significant legal issue for the sector. Current examinations continue to reflect a medium risk of noncompliance, primarily with arbitrage-related or set aside requirements.

The recent examination initiative relating to multi-family housing bonds have reflected a lower-risk segment than expected. Therefore, the risk level has been reduced to medium.

Airport: Examinations of airport bonds support a medium risk assignment.

Sewage: Examinations of sewage bonds support a medium risk assignment.

Student Loans: Similarly to other areas, such as single family mortgage bonds, student loan bonds involve complex arbitrage calculations and the ability to earn and divert illegal arbitrage. Therefore, a medium risk of noncompliance has been assigned to this category of financings.

Hospital/Healthcare: As a result of the changing healthcare industry, hospital systems have recently faced financial situations that have required them to either merge with other hospital systems or privatize. There has been an increased indication of noncompliance in the form of referral information and VCAP requests related to hospital bonds. Consequently, bonds issued to finance hospitals and related facilities are at medium risk of noncompliance.

➤ Low Risk:

Bonds issued to finance or refinance docks and wharves, enterprise zone, local electric facilities, gas and energy, water furnishing facilities, redevelopment, empowerment zone, and other non-government output facilities were determined to have a low risk of noncompliance, primarily due to the low volume of bond issues related to each category.

RELIABILITY OF ASSESSMENT OF COMPLIANCE RISKS BY MARKET SEGMENT

The information used to determine the above compliance risks is data from SOI analysis of tax exempt bond returns. The information is considered in conjunction with the outcome of prior year and current examinations to determine the compliance risk level of each segment.

TAX EXEMPT BONDS
 MARKET SEGMENTATION
 (DOLLARS ARE IN MILLIONS)

DIAGRAM A

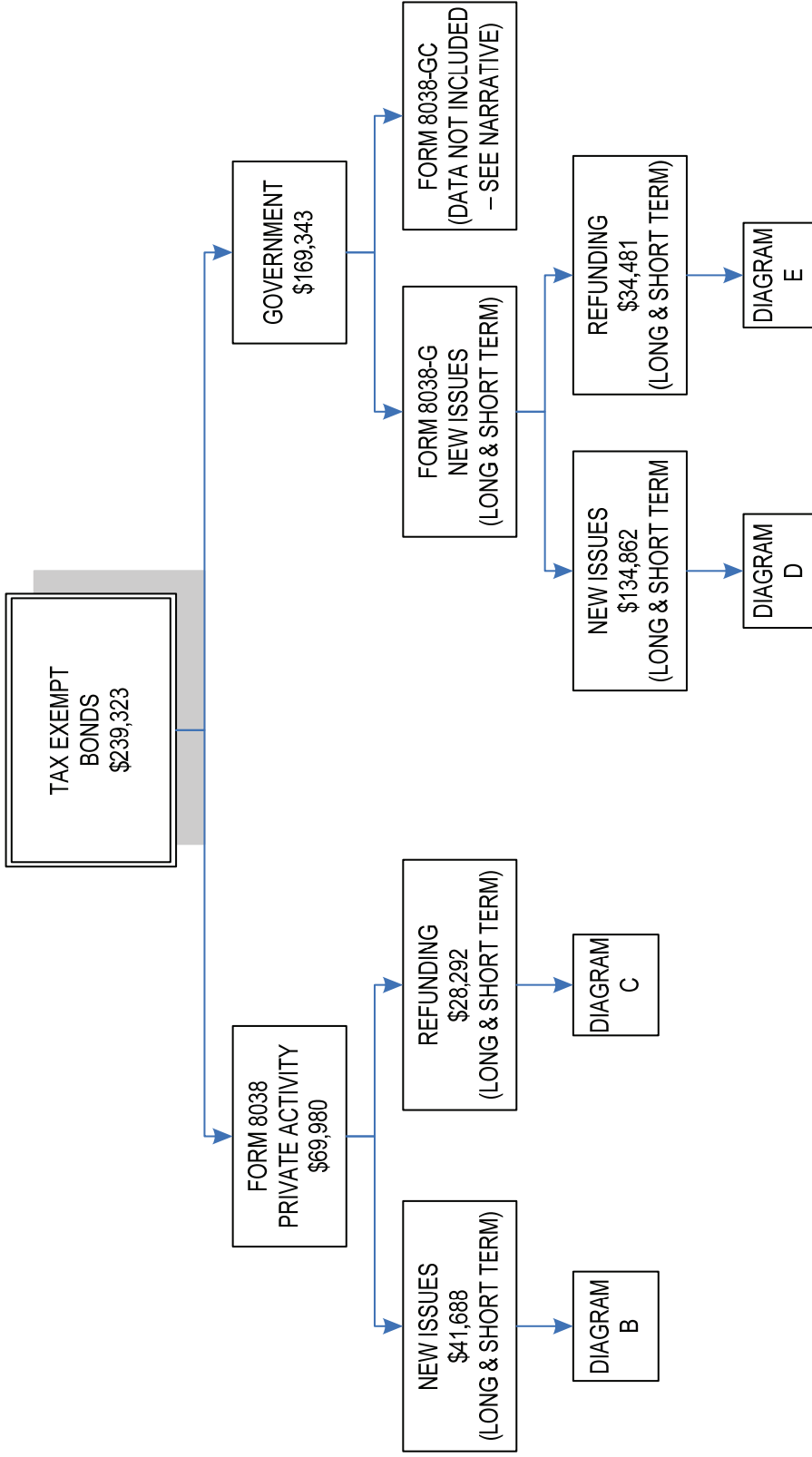

TAX EXEMPT BONDS
 MARKET SEGMENTATION
 (DOLLARS ARE IN MILLIONS)

DIAGRAM B

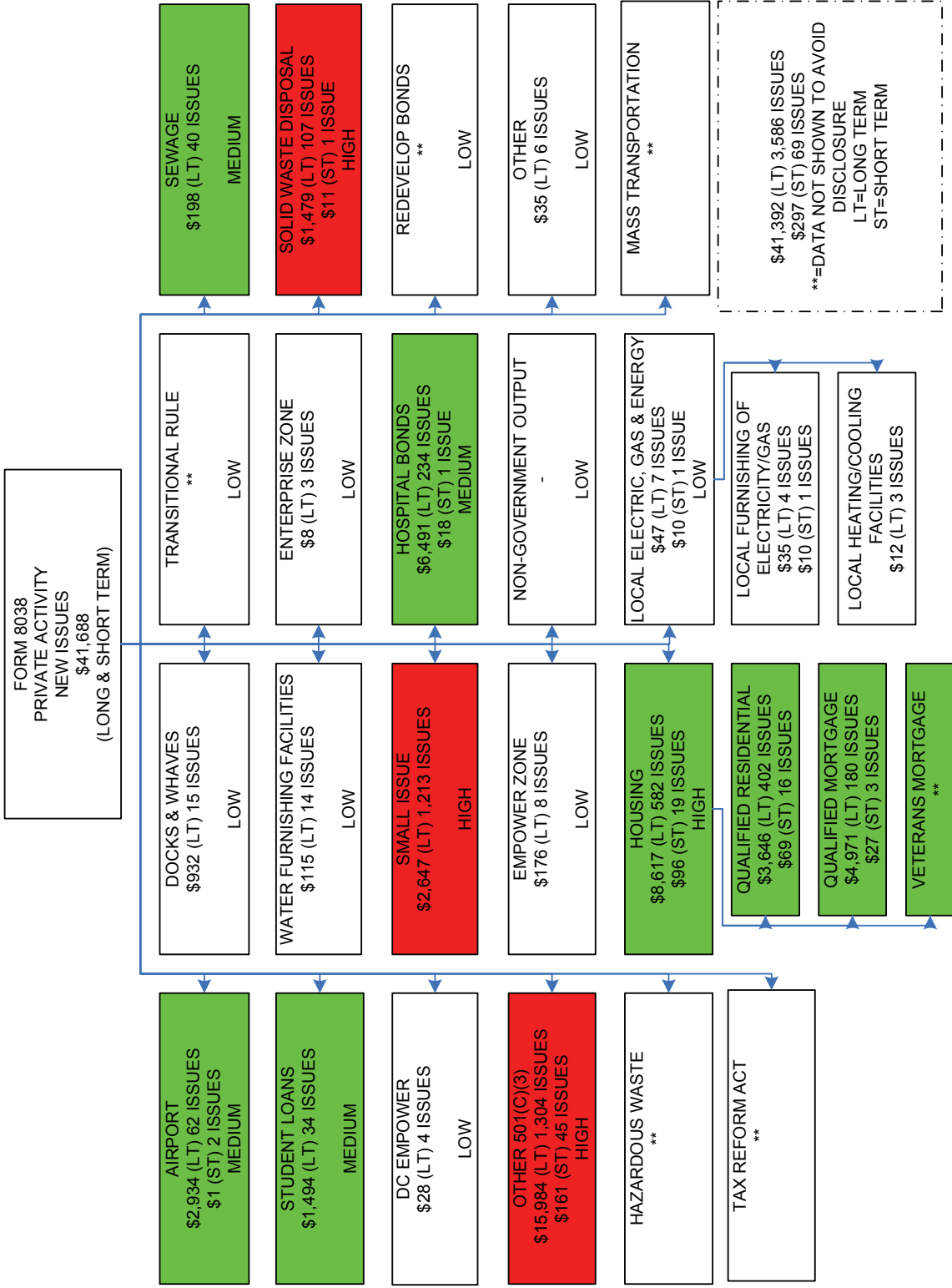

TAX EXEMPT BONDS
 MARKET SEGMENTATION
 (DOLLARS ARE IN MILLIONS)

DIAGRAM C

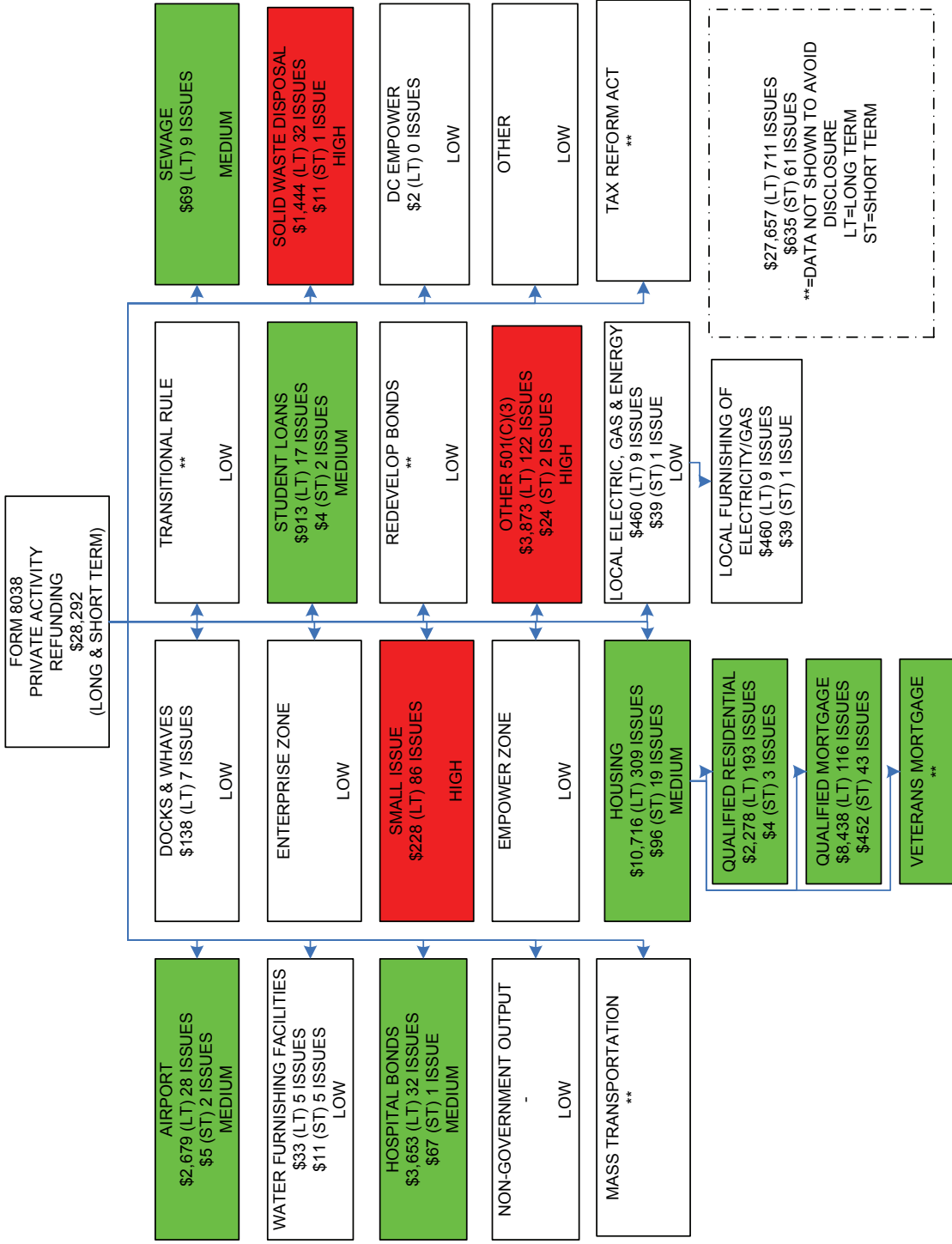

TAX EXEMPT BONDS
 MARKET SEGMENTATION
 (DOLLARS ARE IN MILLIONS)

DIAGRAM D

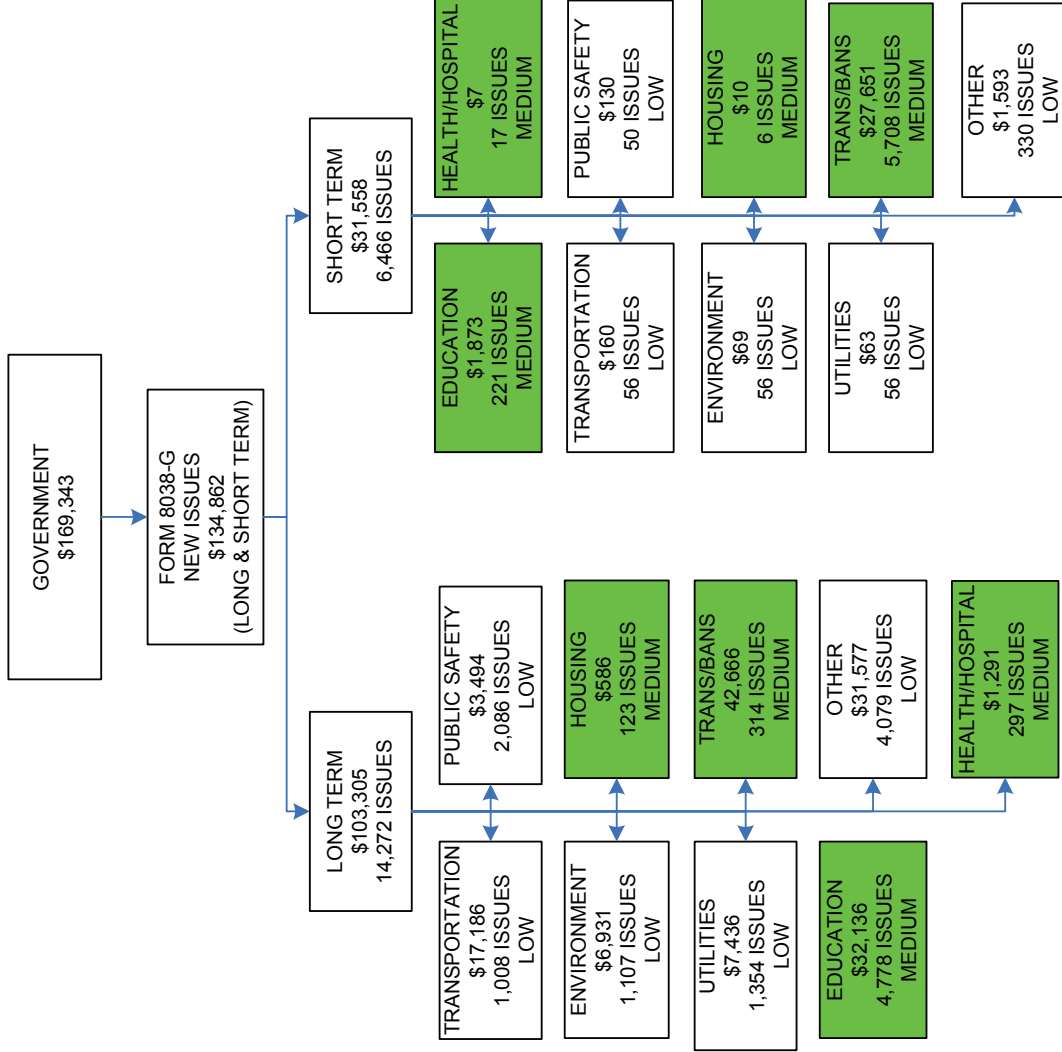

TAX EXEMPT BONDS
 MARKET SEGMENTATION
 (DOLLARS ARE IN MILLIONS)

DIAGRAM E

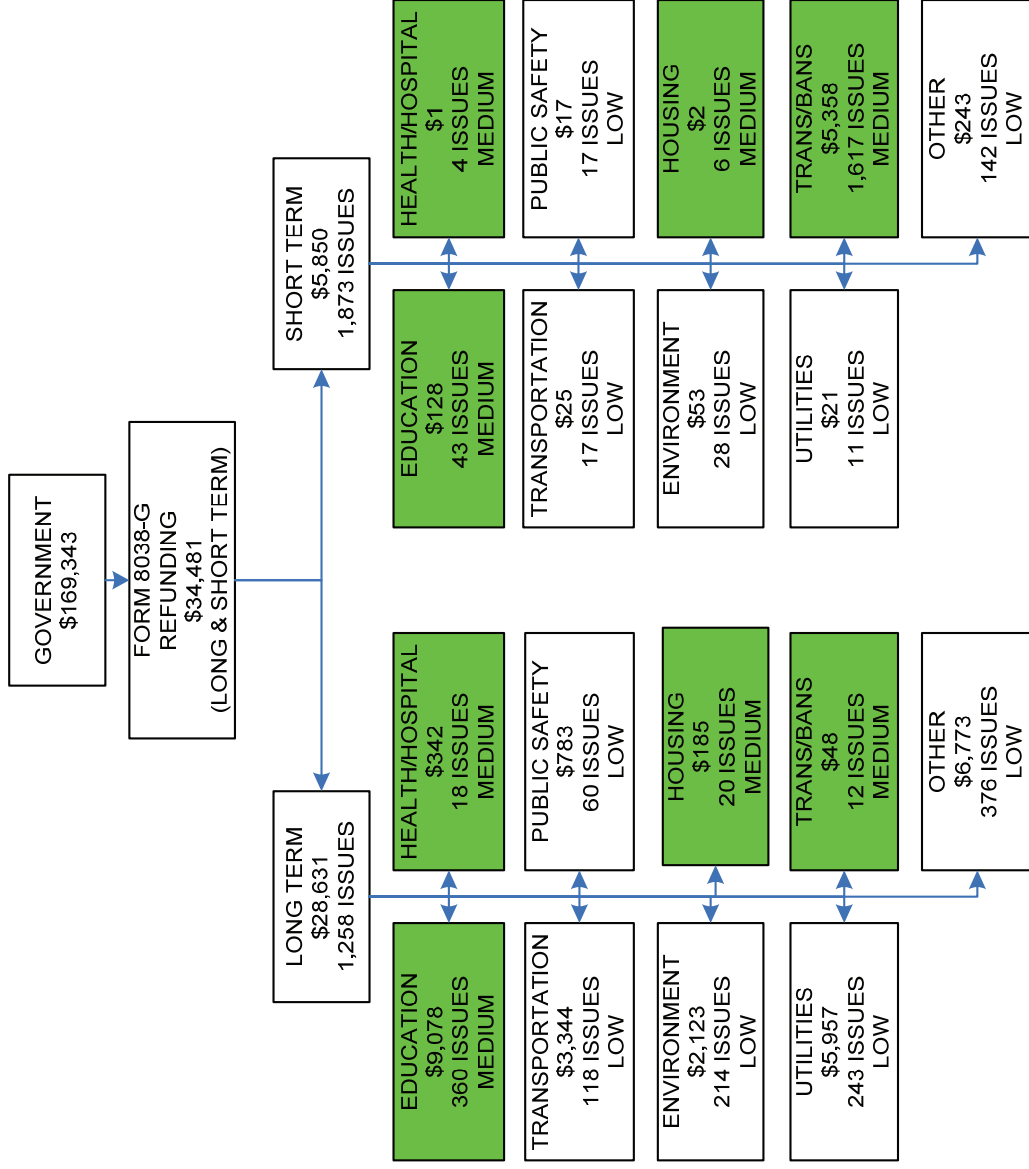

ATTACHMENT IV

TEB Form 5440

The attached Form 5440 is applicable for FY 2006.

