

Biological Services Program

---

**FWS/OBS-77/37**  
**APRIL 1978**

**CONTRIBUTED PAPERS  
ON COASTAL ECOLOGICAL  
CHARACTERIZATION STUDIES**

Presented at the  
**FOURTH BIENNIAL INTERNATIONAL ESTUARINE  
RESEARCH FEDERATION CONFERENCE**

**Mt. Pocono, Pennsylvania  
2-5 October 1977**

**Interagency  
Energy-Environment  
Research and Development  
Program**

Library  
National Wetlands Research Center  
U. S. Fish and Wildlife Service  
700 Cajundome Boulevard  
Lafayette, La. 70506

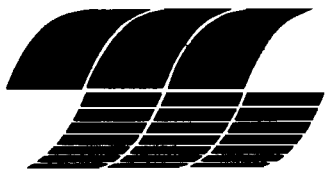

**Office of Research and Development  
U.S. Environmental Protection Agency**

**Fish and Wildlife Service**

---

**U.S. Department of the Interior**

The Biological Services Program was established within the U.S. Fish and Wildlife Service to supply scientific information and methodologies on key environmental issues that impact fish and wildlife resources and their supporting ecosystems. The mission of the program is as follows:

- To strengthen the Fish and Wildlife Service in its role as a primary source of information on national fish and wildlife resources, particularly in respect to environmental impact assessment.
- To gather, analyze, and present information that will aid decisionmakers in the identification and resolution of problems associated with major changes in land and water use.
- To provide better ecological information and evaluation for Department of the Interior development programs, such as those relating to energy development.

Information developed by the Biological Services Program is intended for use in the planning and decisionmaking process to prevent or minimize the impact of development on fish and wildlife. Research activities and technical assistance services are based on an analysis of the issues a determination of the decisionmakers involved and their information needs, and an evaluation of the state of the art to identify information gaps and to determine priorities. This is a strategy that will ensure that the products produced and disseminated are timely and useful.

Projects have been initiated in the following areas: coal extraction and conversion; power plants; geothermal, mineral and oil shale development; water resource analysis, including stream alterations and western water allocation; coastal ecosystems and Outer Continental Shelf development; and systems inventory, including National Wetland Inventory, habitat classification and analysis, and information transfer.

The Biological Services Program consists of the Office of Biological Services in Washington, D.C., which is responsible for overall planning and management; National Teams, which provide the Program's central scientific and technical expertise and arrange for contracting biological services studies with states, universities, consulting firms, and others; Regional Staff, who provide a link to problems at the operating level; and staff at certain Fish and Wildlife Service research facilities, who conduct inhouse research studies.

**CONTRIBUTED PAPERS  
ON COASTAL ECOLOGICAL  
CHARACTERIZATION STUDIES**

**Presented at the**

**FOURTH BIENNIAL INTERNATIONAL  
ESTUARINE RESEARCH FEDERATION CONFERENCE**

**MT. POCONO, PENNSYLVANIA**

**2-5 October 1977**

**Edited by:**

**James B. Johnston**

**National Coastal Ecosystems Team**

**Office of Biological Services**

**Fish and Wildlife Service**

**U.S. Department of the Interior**

**NSTL Station, Miss. 39529**

**and**

**Lee A. Barclay**

**Fish and Wildlife Service**

**U.S. Department of the Interior**

**P. O. Box 12559**

**Charleston, S. C. 29412**

## DISCLAIMER

The opinions, findings, conclusions, or recommendations expressed in this publication are those of the authors and do not necessarily reflect the views of the Biological Services Program, Fish and Wildlife Service, U.S. Department of the Interior, nor does mention of trade names or commercial products constitute endorsement or recommendation for use by the Federal Government.

## PREFACE

A session on the U.S. Fish and Wildlife Service's Coastal Ecological Characterization Studies was held on 3 October 1977 at the Fourth Biennial International Estuarine Research Conference in Mt. Pocono, Pennsylvania, to highlight the important components of the characterization process.

The papers in this report are those presented at the session, with two exceptions. First, the paper entitled *Interim Hierarchical Regional Classification Scheme for Coastal Ecosystems of the United States and its Territories* is not included and may be secured from the author—Terry T. Terrell, U. S. Fish and Wildlife Service, Office of Biological Services, Room 206, Federal Building, Fort Collins, Colorado 80521. Secondly, papers entitled *The Construction of a Conceptual Model of the Chenier Plain Coastal Ecosystem in Texas and Louisiana* and *Maine Coast Characterization User's Guide* are included in the proceedings. The first paper summarizes the modeling effort for the first coastal characterization study—Chenier Plain of Southwest Louisiana and Southeast Texas; while the second paper describes how a user would utilize products from the Maine characterization study.

Funding for the initial characterization studies was provided through the Interagency Energy/Environment Research and Development Program which is planned and coordinated by the Office of Energy, Minerals, and Industry within the Environmental Protection Agency's Office of Research and Development. Inaugurated in fiscal year 1975, this program brings together the coordinated efforts of 77 Federal agencies and departments. The goal of the Program is to assure that both environmental data and control technology are available to support the rapid development of domestic energy resources in an environmentally acceptable manner.

Any suggestions or questions regarding this publication should be directed to:

Information Transfer Specialist  
National Coastal Ecosystems Team  
U.S. Fish and Wildlife Service  
National Space Technology Laboratories  
NSTL Station, Miss. 39529

This report should be cited as follows:

Johnston, J. B. and L. A. Barclay, eds. Contributed papers on coastal ecological characterization studies, presented at the Fourth Biennial International Estuarine Research Conference, Mt. Pocono, Pa., 2-5 October 1977. Office of Biological Services, U.S. Fish and Wildlife Service. FWS/OBS-77/37. 66 pp.



## CONTENTS

	PAGE
Preface .....	iii
Coastal Ecological Characterization—An Overview <i>J. B. Johnston</i> .....	1
Ecosystem Characterization—An Approach to Coastal Planning and Management <i>A. W. Palmisano</i> .....	4
Evaluation of Methodology Used in Ecological Characterization of the Chenier Plain <i>R. H. Chabreck, J. B. Johnston, and J. B. Kirkwood</i> .....	10
User-Oriented Conceptual Modeling in the Ecological Characterization of the Sea Islands and Coastal Plain of South Carolina and Georgia <i>John J. Manzi and Robert J. Reimold</i> .....	19
The Construction of a Conceptual Model of the Chenier Plain Coastal Ecosystem in Louisiana and Texas <i>L. M. Bahr, Jr., J. W. Day, Jr., T. Gayle, J. G. Gosselink, C. S. Hopkinson, and D. Stellar</i> .....	32
Maine Coast Characterization User's Guide <i>Stewart I. Fefer, Curtis Laffin, Larry Thornton, Patty Schettig, and Russ Brami</i> .....	44





# COASTAL ECOLOGICAL CHARACTERIZATION – AN OVERVIEW

J. B. Johnston<sup>1</sup>

## INTRODUCTION

The United States Fish and Wildlife Service (FWS), in response to accelerated development pressures upon the coastal zone of the United States and its territories, has developed an ecological characterization approach for describing these valuable areas.

An ecological characterization is a description of the important components and processes of an ecosystem. The emphasis of ecological characterization, however, is placed on understanding functional relationships.

The objective of ecological characterization is to develop an ecosystem information base, and is unique in that it:

1. Focuses on functional relationships.
2. Relates to specific and geographically well-defined ecosystems.
3. Integrates existing multidisciplinary information.
4. Represents state-of-the-art understanding of the ecological relationships.
5. Provides an ecologically based framework for comprehensive coastal planning.
6. Develops tools for assessment of environmental impacts.
7. Identifies information deficiencies and research priorities.

Among the principal users of the study results are those entities within the FWS which are involved in programs oriented toward the management of coastal areas of the U.S. and its territories. FWS has mandates under the Fish and Wildlife Coordination Act of 1958 and the Water Pollution Control Act of 1972, and has responsibility for the

review of permits for development and discharge activities in U.S. wetlands and aquatic systems. Principal permit authority lies with the U.S. Army Corps of Engineers (USACE) or the Environmental Protection Agency (EPA). Within the FWS, the Division of Ecological Services (ES) Land and Water Resources Development Planning Program has lead responsibility.

Although a characterization will not provide all the answers for reviewing a permit application, it will provide an ecological data base (bibliography, site-specific data, maps, etc.) and describe the area on an ecosystem level. Supplemental data, i.e., field inspections and review of developmental practices for an area, will still be needed by the ES biologist and his counterparts in other agencies, for the preparation of final reports.

Characterizations will be available for use by all FWS programs related to coastal resource management and planning. Other applications are assessing the Outer Continental Shelf (OCS) development, Coastal Zone Management (CZM), and Section 208 water quality planning. Characterizations will identify fish and wildlife populations and their habitats that could be impacted during ecological emergencies such as oil spills. Perhaps of even greater value, characterizations will provide foundations for planning during formulation of emergency response plans, i.e., Coast Guard and EPA oil-spill contingency plans.

Government agencies other than the FWS are also considered to be primary users of characterizations. These agencies include the National Marine Fisheries Service, Bureau of Land Management, EPA, USCG, COE, State CZM, and fish and game agencies. Additional users could include conservation groups, academic institutions, and the various industries or service companies involved in coastal developments. Any agency or private group with an interest in coastal resource decisionmaking should be able to carry out its responsibilities more

---

<sup>1</sup>National Coastal Ecosystems Team, Office of Biological Services, Fish and Wildlife Service, U.S. Dept. of the Interior, NSTL Station, Miss. 39529.

effectively by applying a coastal characterization.

Coastal areas presently being characterized and anticipated study completion date are: (1) the Chenier Plain (Southwest Louisiana and Southeast Texas)—winter 1978; (2) the Sea Islands and Coastal Plain of Georgia and South Carolina—summer 1979; (3) the Pacific Northwest (Northern California, Oregon, and Washington)—winter 1978; and (4) the Rocky Coast of Maine—winter 1979. These study areas were delineated on the basis of ecological characteristics; consequently the characterizations are primarily regional in scope and are not necessarily limited to political or geographic boundaries. Some states, like Florida and Alaska, include all or parts of more than one distinct coastal ecosystem.

The initial characterization study areas were selected on the basis of their diversity, geographic distribution, high fish and wildlife value, and their proximity to actual or proposed OCS and/or other major developmental activities. These criteria will also be used for selecting future coastal areas for characterization.

The characterization process requires approximately 18 to 30 months to complete, depending on the ecosystem being studied. The initial important steps include the development of a conceptual model, data collection and synthesis, and a pilot study.

### CONCEPTUAL MODEL

A conceptual model describes and explains the casual and obligatory relationships, interdependencies, and controlling factors among and between the biotic and abiotic components of a coastal ecosystem. Components of a conceptual model include productivity, energy and materials, physical processes, trophic structure, species diversity, and socioeconomic features.

The objectives of a conceptual model as it relates to a characterization study are to:

1. Develop qualitative models to describe a particular coastal ecosystem and its component resources, processes, and relationships through a hierarchical approach.
2. Identify, and establish priorities for, information needs and data requirements.
3. Provide framework for analysis and synthesis of data, and for final products.
4. Identify data deficiencies in various levels of the hierarchy.

### DATA COLLECTION AND SYNTHESIS

Although the ecological (conceptual) models are important in the formulation of data collection and synthesis, the needs of users are considered in the development of the characterization. Users are also important in identifying available data sources. A characterization uses both standard sources (books, journals, monographs, theses, and dissertations, etc.) and unpublished data which are not readily available to users. Compilation of unpublished data represents a major task in the study. Additionally, pertinent information from outside the study area is used when it can effectively be applied to the study area. Since no new field or experimental data will be generated, a thorough search of existing information is vital to the quality of the study.

### PILOT STUDY

The pilot study or test characterization is a subunit (i.e., watershed, basin, or specific region), within the ecosystem being characterized. The primary objective of the pilot study is to provide examples of modeling techniques, data collection and synthesis, and to review data portrayal and format being proposed for the final characterization atlas and data source appendix. Examples from the pilot study are reviewed by a wide range of users, necessary revisions in methodologies are made, and the study proceeds to completion. Pilot efforts are usually completed midway through a study.

### FINAL PRODUCTS

The final products or outputs of a characterization are the ecological (conceptual) models, ecosystem characterization atlas (narratives, tables, charts, and graphics), and data source appendix (bibliography of all data sources, pertinent data, species lists, etc.). However, the format of these products varies among the present four studies. For example, large-scale maps are used in one area and small-scale maps in another. These differences derive from user preferences, available data for the ecosystem, and contractual agreements with existing contractors. Standardized methodologies and specifications for conducting future ecological characterizations are being prepared based upon experience gained during the initial four studies.

## SUMMARY

Characterizations integrate functionally the major elements of an ecosystem. Elements include, but are not limited to, physiography and geology, climate, and physical transport mechanisms. Examples of physical transport mechanisms are hydrology, sediment flux, physical oceanography (in the case of marine systems), energy flows and trophic relationships, and atmospheric transport. Characterizations describe the important species, populations, and communities in the ecosystem, with particular emphasis on those organisms perceived as being of importance (recreational or commercial) to man or vital to the natural functioning of the ecosystem being studied. Population estimates do not require precise statistical sampling, but where feasible, estimates are used to address the extent and causes of natural variation. The main objective of a characterization is to describe socioeconomic, physical, and biological features as interacting components, thereby establishing a foundation upon which impacts of man, including modifications to the ecosystem, can be predicted.

Unlike a baseline study, many of the elements described in the characterization are important, not because they are expected to change as a result of a proposed development, but because knowledge of these elements is needed to understand the ecosystem. Characterizations should be an early step in the analysis of any coastal ecosystem under major study for impact analysis purposes, for activities such as coastal and onshore impacts from OCS, for redirection of freshwater inflows into estuaries, for increased residential or commercial developments in a coastal area, etc. The characterizations will provide decisionmakers, and those advising decisionmakers on ecological matters, with guidance tools for the planning process. Guidance will be in the form of broad ecosystem understanding and will not be impact specific. Characterizations should aid in assessing the effects of a variety of coastal developments. The characterization approach has the additional benefit of pinpointing data gaps, thereby identifying research priorities.

# ECOSYSTEM CHARACTERIZATION—AN APPROACH TO COASTAL PLANNING AND MANAGEMENT

A. W. Palmisano<sup>1</sup>

## INTRODUCTION

We are at a crossroads in our technological evolution. Having successfully passed through stages of empirical and scientific approaches to progress, we are at the threshold of a new age which will mold our future through the integration of knowledge acquired in many diverse disciplines. Problems we face today are so complex and wide-ranging that solutions require a holistic approach. The principal strands of the new web of understanding are supported by three disciplines: technology, sociology, and bioecology; together they comprise our environment (fig. 1).

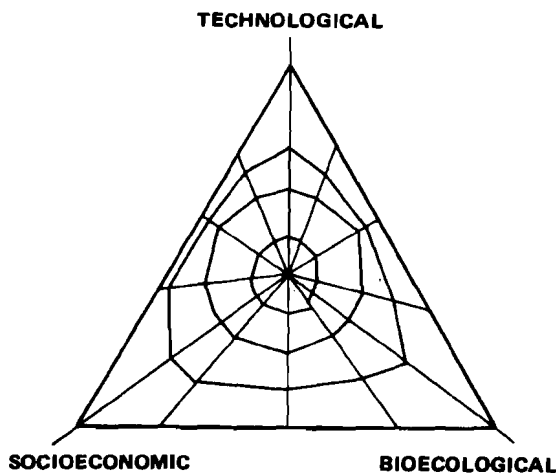

Figure 1. Information web required for comprehensive natural resource development.

Bioecological components alone can range in scope from systems as small as the gene to those as large as the biosphere. This paper suggests a mid-level approach to studying ecosystems.

Concentrated human populations and diverse development activities have focused on the con-

tinental fringes. Coastal ecosystems offer a particularly complex challenge requiring the integration of information dealing with air, land, marine, estuarine, and freshwater systems. It is against this background that the ecosystem characterization process described in this paper has been developed.

## DEFINITION AND PURPOSE

The concept of ecosystem characterization is not very profound or complicated. A useful definition is a description of the important components and processes comprising an ecosystem and an understanding of their important functional relationships. Strong emphasis is placed on systems understanding through structured integration of information from the physical and biological sciences. Key elements of the concept are outlined below:

### Ecosystem Characterization—Definition

- Related to a specific ecosystem.
- Provides a basic perspective of the state of knowledge for the given system.
- Provides a description of the important ecosystem components and functional processes.
- Provides a mechanism for ecosystems understanding through the integration of components and functional processes.

### Ecosystem Characterization—Purpose

Provides an understanding of ecosystems to assist in:

- Integration of complex ecological information.
- Identification of information deficiencies.

<sup>1</sup>Office of Biological Services, Fish and Wildlife Service, U.S. Dept. of the Interior, Washington, D.C. 20240.

- Establishing research priorities.
- Comprehensive planning.
- Assessment and prediction of environmental impacts.
- Developing mitigation procedures and alternatives for minimizing environmental impacts.

### APPROACH

Ecosystem characterization is a structured approach to the synthesis of diverse environmental information. To be effective, each step of the process must be followed sequentially as outlined in figure 2.

### ECOSYSTEM DESCRIPTION AND BOUNDARIES

The ecosystem is a basic unit for describing natural systems, and has become widely accepted by scientists and resource managers. A description of an ecosystem includes:

- Functional relationships between organisms and their physical environment.
- Plant and animal assemblages, which are relatively homogenous response units, often referred to as communities.
- Open systems through which energy and matter are continuously exchanged.

This latter principle has made it difficult to delineate the precise boundaries of a given system.

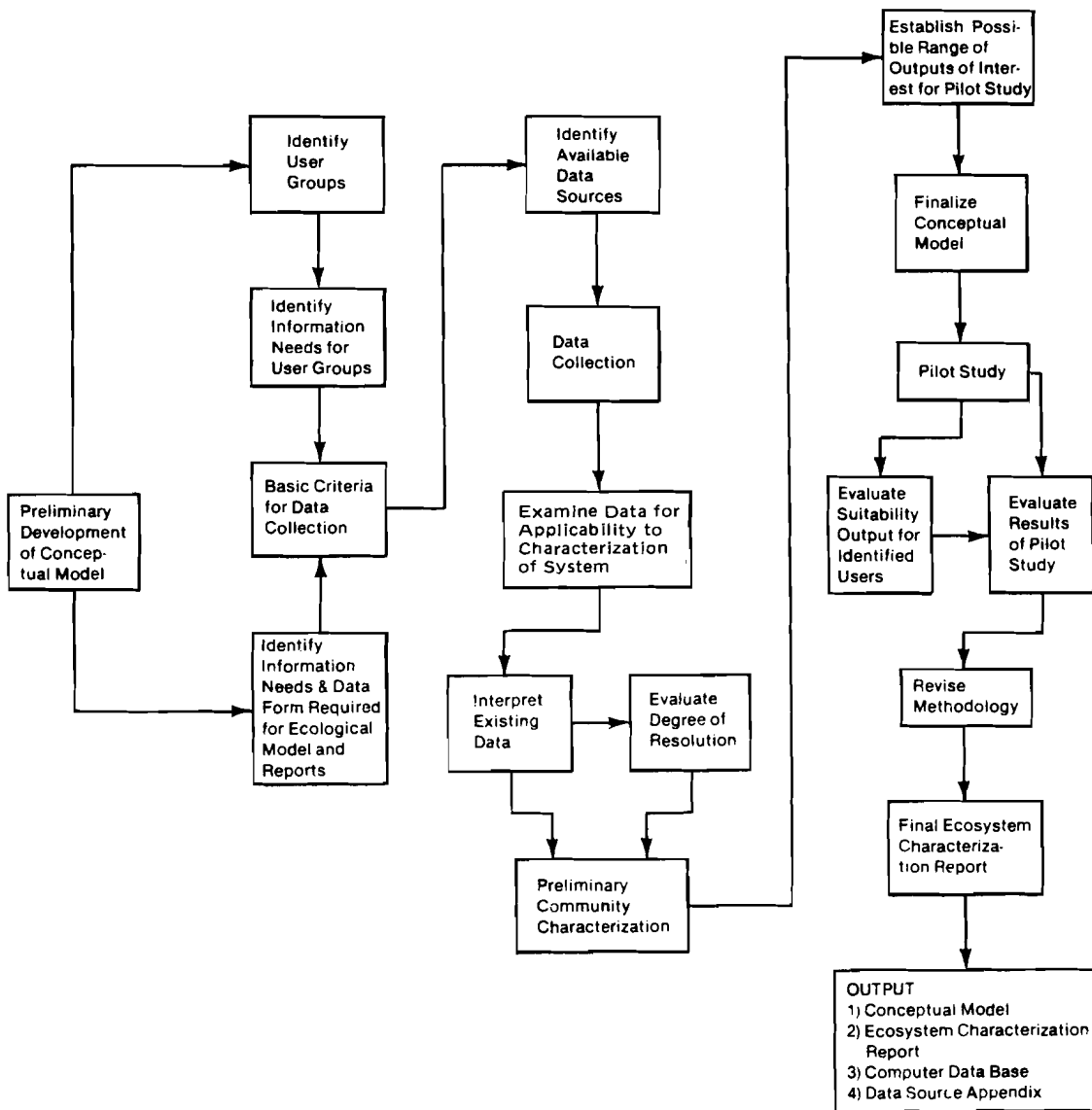

Figure 2. Ecosystem characterization approach.

Coastal ecosystems are more easily envisioned than described. The rocky coast of Maine, the extensive low-lying wetlands and bayous of Louisiana, the mangrove-coral systems of tropical Florida, and the barrier island coast of Texas can each be conceived as unique coastal ecosystems and adjacent to other coastal systems.

Forces molding the structure of the system include weather, wave energy, sediment transport, and the long-term processes of subsidence as well as climatic and geologic change. These physical processes result in the establishment of the environment and substratum upon which biological communities develop. In turn, the communities influence the continued evolution of the system.

The Chenier Plain ecosystem, for example, is considered a transition zone between the active Mississippi River delta to the east and the relatively stable barrier island system to the west. Fluctuations of sediment availability from the Mississippi River over the past 5,000 years have resulted in the accretion of a vast coastal system composed of emergent wetlands, lakes, ponds, estuaries, tidal channels, and slightly elevated stranded beach ridges. Like similar extensive estuaries, the Chenier Plain owes its existence to the relative stability of sea level over the past several millennia and to the abundant sediment supply of a major river. Ecosystem boundaries, although defensible, have been somewhat arbitrarily established and reflect the functional differences between adjacent systems. With this natural background plus a 30-year history of onshore and offshore oil and gas and other development activities, the Chenier Plain provides an ideal setting for piloting the implementation of the ecosystem characterization concept.

### CONCEPTUAL ECOSYSTEM MODEL

After the boundaries of the system have been established, the next step is the development of a conceptual ecosystem model. The model guides the entire characterization effort by providing the framework for identifying important natural resource components of the system and the functional processes which affect their survival and productivity.

The modeling approach for the Chenier Plain involves a four-level analysis of the system. At the first level, a broad regional model considers the entire ecosystem, emphasizing geomorphology and the geologic processes responsible for the origin of the system, and the long-term system changes.

Most natural changes at the ecosystem level occur on the order of thousands of years and it is difficult to incorporate this information into planning and impact analysis procedures. The framework is useful, however, for providing a proper perspective to the other components of the system (fig. 3).

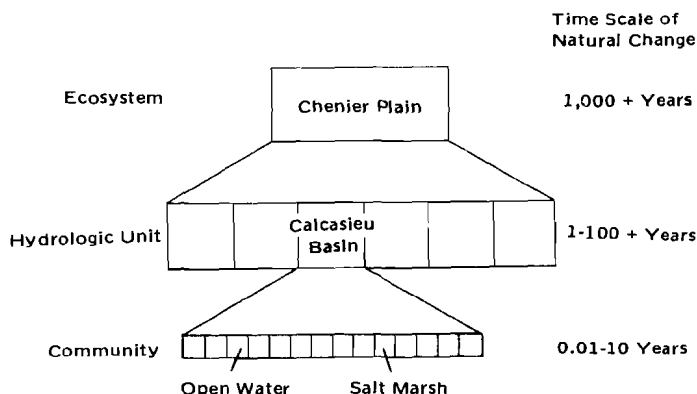

Figure 3. Stratified organization of conceptual model of Chenier Plain ecosystem.

At the second level, the Chenier Plain ecosystem is subdivided and modeled as six subsystems generally representing different drainage basins or hydrologic units. Hydrologic processes dominate basin function and provide a mechanism for integrating basin components. Natural change occurs on the order of one to several hundred years, a useful scale for planning and impact analysis.

The relatively homogenous units which variously might be termed communities, associations, or habitats are the third level of resolution. Basins, therefore, emerge as spatially heterogeneous areas composed of a number of interacting habitats. At the community level, change is constant, seasons come and go, plants and animals live and die and man's impact on the environment is most apparent. It is the habitat which is altered by dredging, polluted by oil spills, or drained for agricultural, urban, or industrial development. Most environmental changes are viewed in respect to these habitats. The conceptual model identifies functional relationships between habitats, which would then permit planning and cumulative impact analysis, at the basin level, for the Chenier Plain.

At the fourth level of the hierarchy, the natural history, growth dynamics, and environmental limits are considered for species of commercial, recreational, or functional importance in the Chenier Plain region.

Modeling diagrams, interaction matrices, and narrative accounts are used to highlight important resource components and processes. A "blueprint" for guiding future data-collection synthesis and analysis is then prepared as the final stage of the conceptual model.

#### **INFORMATION SYNTHESIS AND ANALYSIS**

After the priorities for ecosystem information needs have been established by the conceptual model, data compilation is initiated. Fundamental to ecosystem characterization is the structured accumulation of all existing information identified by the model as being significant. This phase of the process requires the identification of all published material as well as information stored in files, in unpublished reports, and in the heads of individuals familiar with the area's ecology.

The conceptual model also assists in making full use of the available information by establishing the boundaries of transferability. Site-specific information from a single estuary, for example, might be applicable to other estuaries within the same hydrologic unit but data from outside the system would have to be carefully screened to establish relevance. In this way maximum use is made of all available information.

Data are assembled into two reference systems: a literature citation system and a data source appendix. Material referenced in the literature cited section would be available in major libraries within the geographic area of the characterization study. Standard sources (books, journals, monographs, theses, and dissertations, etc.) would be included in the literature cited section. The data source appendix contains a listing of information and, where appropriate, actual data compiled from unpublished sources that are generally unavailable to users.

Major products of the data synthesis and analysis phase include:

- The Ecosystem Characterization Report describing the system and highlighting important natural resources and the processes which affect their distribution and productivity. The report is designed primarily to provide an understanding of the system through sufficient narrative, graphs, maps, tables, and illustrations. It does not represent the primary data source, although a comprehensive literature cited section is part of the report.

- Data Source Appendix forms the major data base developed during the course of the study. Together with the published literature, it represents a primary source of information on the environment of the ecosystem. Steps are being taken to develop a standardized system to locate, access, and transfer the information.

#### **SCHEDULING**

An important aspect of the characterization approach to planning environmental study programs is that useful information can be developed early in the program. Approximately 20 months are required to complete the process. The first activity is a general survey of user needs focusing on Federal and State agency interests, followed within 3 months by a draft of the conceptual model. A pilot characterization area is selected and an intensive data acquisition phase is undertaken. The purpose of the pilot area, usually a basin or region within the ecosystem, is to develop and present the data format which will be used in the final characterization report and data source appendix. The user group will have the opportunity to review the pilot documents approximately 6 months after work begins, providing ample time to incorporate necessary changes into the final reports. After the format and content have been established through the pilot effort, the ecosystem characterization can then proceed rapidly to completion.

#### **USER RELATIONSHIPS**

The test of an information system is its value when applied to solving real problems. To effectively meet user needs their guidance must be sought and incorporated into the planning and development of all phases of the process.

Ecosystem characterization will not provide solutions to all environmental problems arising in the coastal zone. However, it does provide a base of ecological information which will have application to most situations. Activities for Coastal Zone Management (CZM), managed by National Oceanic and Atmospheric Administration (NOAA), range from comprehensive planning, requiring a broad base of information, to site-specific disturbances. To meet these needs, the information base must contain general information highlighting the

resources and processes comprising the system as well as specific information on the distribution of fish, wildlife, and their essential habitats. The stratified approach presented in the Chenier Plain conceptual model describes a mechanism for structuring information which will address this broad range of needs.

Program specific information is required in addition to the ecosystems data. Figure 4 is a schematic depicting some of the action programs which could use the ecosystem data base. In each case, supplemental information must also be available. Agencies responsible for managing action programs usually have resources available to develop program specific information. The Outer Continental Shelf (OCS) leasing and development program, for example, is managed by the Bureau of Land Management (BLM) and U.S. Geological Survey (USGS), respectively. As part of the leasing program, the BLM has undertaken environmental studies to assess the long-term impacts of OCS development, and to minimize detrimental environmental impacts. Specific kinds of information are being developed in the lease areas to meet the needs of the leasing program. A broad base of ecological data could complement the OCS environmental studies program, assist in preparation of resource

assessments and impact statements, and help determine program requirements. Lead responsibility within FWS belongs to the Office of Biological Services (OBS).

In the event of an oil spill from OCS development, the ecological characterization would provide an information base to the Coast Guard (CG) of important resources that could be impacted. This base would also be used by the FWS's Environmental Contaminant Evaluation (ECE) and Ecological Services (ES).

The Fish and Wildlife Service (FWS), as mandated under the Fish and Wildlife Coordination Act of 1958 and the Water Pollution Control Act of 1972, has responsibility for the review of applications to permit development and discharge activities in the wetlands and aquatic systems of the United States. Decisions to issue permits are the responsibility of the U.S. Army Corps of Engineers (USACE) or the Environmental Protection Agency (EPA). Lead responsibility within the FWS lies with the Land and Water Resources Planning Program. Dredging and other wetland alterations in the coastal zone may be very site-specific and result in localized change. Information required to adequately assess the impacts of such activities differs substantially from that

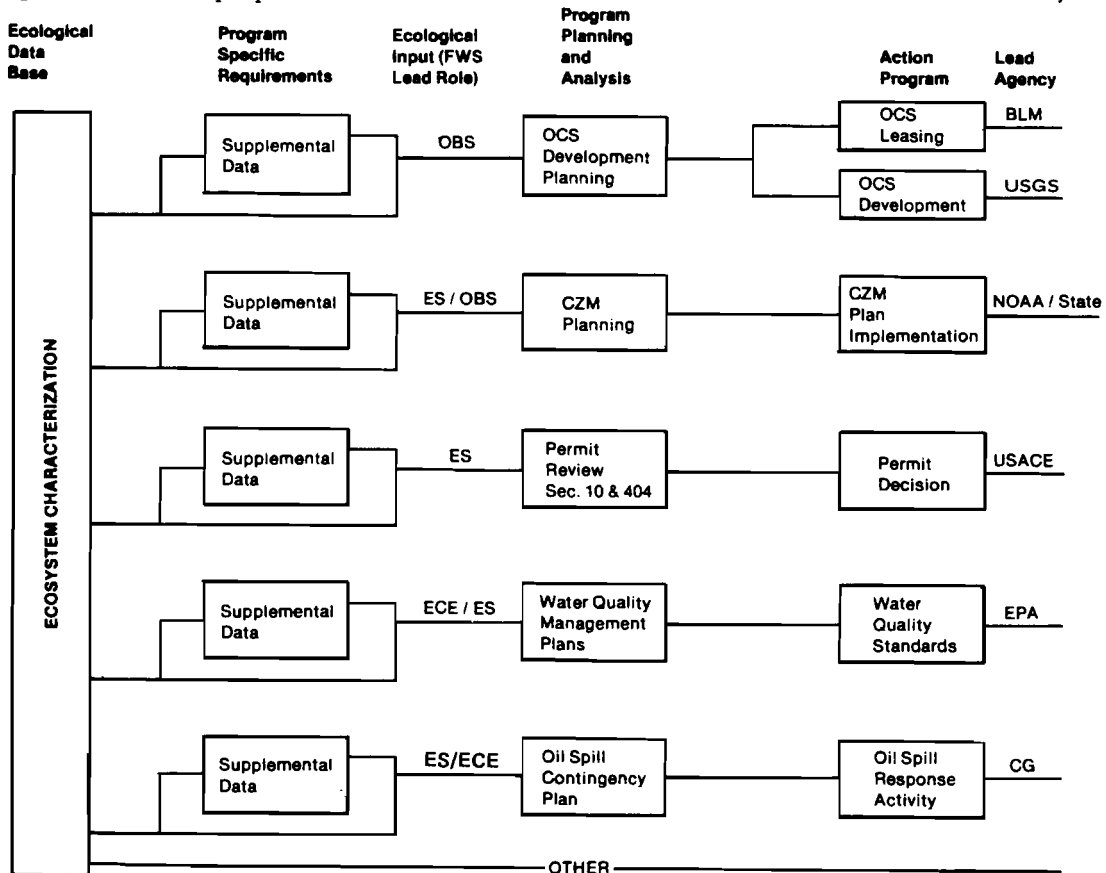

Figure 4. Relationship of ecosystem characterization information to supplemental data requirements and selected Fish and Wildlife Service-related action programs in the coastal zone.



required for OCS leasing. Ecosystem characterizations, however, could provide information on the distribution and value of wetlands and fish and wildlife resources in the vicinity of the proposed development. Much of the basic site-specific information will be contained in the data source appendix. Furthermore, the ecosystem characterization report would assist in assessing impacts on the important natural functional processes of the system, e.g., alteration of salinities and currents, effects on primary and secondary productivity, sediment transport processes, etc. Information regarding the effects and mitigation procedures specifically associated with dredging must be provided from supplemental sources such as the U.S. Army Corps of Engineers Dredge Material Research Program. The ecosystem characterization should be regarded as one of a number of tools required to protect and manage living resources. To be effective, other more specialized tools will also be required. It is important that users recognize the tools available to them and the purpose for which they were designed.

### PROJECT STATUS

To date, four coastal ecosystems are being characterized using the approach described. The Chenier Plain study of southwestern Louisiana and southeastern Texas was initiated in April 1976 and is scheduled for completion in late 1978. The other three studies were started in February 1977. They include the coast of South Carolina—Georgia, the rocky coast of Maine, and the Pacific coast from Cape Mendocino, California to Cape Flattery, Washington. These studies are due for completion in 1979. Funding has been provided through the Federal Interagency Energy-Environment Research and Development Program (FIE/ER&D) administered by the Environmental Protection Agency. The Fish and Wildlife Service has been responsible for the design and management of the characterization contracts. There are approximately 15 coastal ecosystems fringing the 48 contiguous States. The FIE/ER&D program has provided a mechanism to rapidly advance our understanding of a significant portion of the coastal zone and it is hoped that the techniques developed in this program will have broad application by other agencies to other areas.

### CONCLUSION

Decisions facing natural resource management become increasingly complex as knowledge advances and interactions are better understood. Improved methods of data integration will become more essential to the application of existing information. Until holistic systems analysis becomes more effective, we will have to rely on modular components to integrate information. Such modules, especially regarding natural systems, can readily be adapted to more comprehensive programs, if properly designed.

The characterization process, as outlined, addresses an important functional unit of the environment—the ecosystem. The approach involves the delineation of the physical boundaries of the system, preparation of a functional conceptual ecosystem model, synthesis and analysis of existing information using the model as a “blueprint,” and the preparation of an interim pilot characterization report. The latter report, after review by the user group, will permit the effective production of the final ecosystem characterization report. During the process most of the relevant information about the system will be brought together in a data source appendix. Guidance throughout the project is provided by a user committee to assure that the information will meet action program needs.

The current energy dilemma may be the first true test of our nation's ability to marshal the diverse knowledge we have accumulated over the past few centuries into a program which assures our survival and strives at least to maintain the cultural standards to which we have become accustomed. Ecosystem characterizations can provide an important ecological foundation from which to plan and manage our natural resources.

## EVALUATION OF METHODOLOGY USED IN ECOLOGICAL CHARACTERIZATION OF THE CHENIER PLAIN

R. H. Chabreck,<sup>1</sup> J. B. Johnston,<sup>1</sup> and J. B. Kirkwood<sup>2</sup>

### INTRODUCTION

Increasing uses of coastal areas by developers, plus increasing public awareness of the value of living resources in these areas, have resulted in increasing conflicts concerning land and water uses. These conflicts can be resolved and reasonable development can proceed while, at the same time, productivity is maintained, if a good understanding of the functions of these fragile areas and more precise methods of predicting the effects of further alterations can be developed. The ecological characterization process was devised by the Fish and Wildlife Service (FWS) as a procedure for providing this understanding. Characterizations provide a description of the important environmental and socioeconomic resources and physical processes comprising coastal ecosystems, and an understanding of the dynamic relationships of these systems by integrating existing resource data as a functional ecological unit.

The area selected for the initial ecosystem characterization was the Chenier Plain of southeastern Texas and southwestern Louisiana. This area is an important producer of fish and wildlife resources; it is subjected to a wide variety of land use practices; it contains large areas of vital natural habitat such as coastal marshes, estuaries, and shallow offshore waters; and it supports several endangered and threatened species. There is a large amount of biological and environmental data available from previous studies of this ecosystem, and the Chenier Plain area has a long history of development associated with industrialization, mineral extraction, navigation, flood control, and agriculture. Through investigation and evaluation of the productivity of resources that have been subjected to various intensities of development, it should be possible to formulate precise impact predictions.

Since the Chenier Plain characterization was the first investigation of this type to be initiated, an important aspect of the project was an evaluation of the methodology used. This evaluation was needed also for the orderly execution of subsequent characterizations of other coastal ecosystems. A methodology evaluation made it possible to identify techniques which effectively served to meet project objectives, and at the same time it identified procedures that had not contributed significantly.

Important aspects of the characterization methodology to be evaluated in this paper include the steering committee concept, user needs survey, conceptual modeling, area delineation, type of mapping, data search and presentation, and pilot study. This paper presents the results of these evaluations and suggests alternative procedures where unsatisfactory results were obtained.

### STEERING COMMITTEE CONCEPT

In order to facilitate active input into the characterization study by others within and outside the FWS, various State and Federal agencies closely involved with activities within the Chenier Plain were asked to assign a representative to a steering committee. These committee members were assigned on the basis of their understanding of the area or special knowledge of certain aspects of the characterization process. The Steering Committee reviewed progress made by contractors at regularly scheduled periods, assessed this progress, and made recommendations to the FWS Project Officer regarding future study areas.

The initial meeting of the Steering Committee was held prior to the beginning of work. Most members showed a strong interest in the project and responded with both oral and written reviews of material presented to them. Enthusiasm remained high during the project and attendance at meetings was even higher than anticipated. The committee size (six) for Chenier Plain was accept-

<sup>1</sup>National Coastal Ecosystems Team, Office of Biological Services, Fish and Wildlife Service, U.S. Dept. of the Interior, NSTL Station, Miss. 39529.

<sup>2</sup>Office of Biological Services, Fish and Wildlife Service, U.S. Dept. of the Interior, Atlanta, Ga. 30347.

able and each person had adequate time to actively participate in the discussion.

The Steering Committee concept proved to be an important aspect of the characterization and assured establishment of priorities necessary to cover all areas of potential interest to resource managers and other user groups. The Steering Committee concept has been continued in the other characterization studies.

### USER NEEDS SURVEY

The Chenier Plain characterization was intended to serve primarily as a resource management tool. Thus, in order to develop a characterization methodology which would achieve this objective, it was necessary to first identify the nature and relative magnitude of the various types of ongoing resource management efforts and other related activities occurring within the study area. The data required to enable managers to make sensible decisions for resource utilization were identified for various regulatory organizations. Also, it was necessary to ascertain the level of detail and preferred formats for data presentation which were most directly applicable and interpretable within the context of these management activities.

A preliminary list of users to be contacted was compiled and circulated to Steering Committee members and other contacts for review. The additions and modifications to the list which were suggested were then incorporated into the survey plan. Further additions to the list were made based on the recommendations of several respondents to a questionnaire. The potential users were then classified into two groups: those to be interviewed personally and those to be contacted only by questionnaires and telephone followup, as necessary. Those organizational representatives selected for interviewing were thought to be more immediately involved in policy formulation, decisionmaking, and research activities within the Chenier Plan.

A questionnaire was used to determine user needs. The questionnaire was designed as a checklist of all resources and possible areas of interest. The draft questionnaire was circulated to members of the Steering Committee for comments and proposed revisions before it was distributed to the users that had been identified. Less than half of the questionnaires were returned by the date requested. Three out of over 90 recipients reported that they elected not to respond. A telephone followup was employed to maximize the information

yield. When a 90 percent return was achieved, a final analysis was performed on the responses.

The returns were grouped into categories according to the management responsibilities of the users, as indicated by responses. Those categories are identified below:

1. Project and permit review on a case-by-case basis.
2. Environmental planning for water related projects (including coastal engineering, flood control, water allocation, etc.).
3. Resource management for fish and wildlife habitat maintenance.
4. Coordination of coastal zone activities.
5. Design and enforcement of environmental legislation.
6. General land use planning.
7. Research and experimentation.
8. Environmental health and agricultural interests.

Clearly, the management responsibilities of the various groups overlapped into a second or even third category. This categorization was designed to identify the respective groups by what appeared to be their major management focus. One objective of this categorization was to ascertain if the data utilized and the data preferred were significantly different according to the responsibilities of the various user groups. In some cases, therefore, responses were included in two categories.

Data needs showed equal weighting by users in regards to their reliance on floral, faunal, and physical area features. There was no difference demonstrated among the management groups except that the water-related management groups expressed preferential dependence on physical data. Answers to questions on environmental data needs may be ranked into data categories. The most important categories (over 70 percent interest) to users are shown in Table 1.

The user needs survey is not being used in other characterization studies because it did not prove to be cost-effective and the required Office of Management and Budget clearance causes untimely delays. It appears that steering committee members and FWS personnel provide the most economical and effective means for acquiring necessary information on user needs.

Table 1. Potential User's Interests by Data Category<sup>a</sup>

Category	% of respondents indicating interest
Habitat classification	80.6
Based on dominant vegetation	83.3
Based on physical parameters	77.8
Productivity	80.6
Dominant fish	72.2
Sport species	77.8
Endangered species	77.8
Food webs	75.0
Salinity regime	77.8
Precipitation	72.2
Sediment type	75.0
Soil type	72.2
Water quality	86.1
Industrial projects	72.2

<sup>a</sup> Includes only categories in which at least 70% of respondents indicated interest.

## DATA PRESENTATION FORMATS

The survey of potential users of environmental data indicated little preference for data formats. All groups reported that they employ maps, charts, tables, and reports with about the same frequency and all groups rely to a lesser extent on computerized information. The apparent tendency to deemphasize computerized information may reflect economic constraints, limited computer access, lack of valid data banks, or mistrust of computerized printouts. In response to the survey concerning preferred data presentation formats, computer tape and flow diagrams were again deemphasized, but maps were preferred (Table 2). There was no difference in the format preferences among different management interests. However, the permit and project review group preferred a significantly higher scale than presently available. For example, representatives of the Galveston and Lafayette FWS field offices indicated that maps and photos currently used are at the 1:24,000, and 1:62,500 levels of resolution. The representatives expressed a desire to have the information provided at the 1:2,000 and 1:5,000 levels. Potential users for the other characterization studies have expressed essentially the same type of data format priorities.

## CONCEPTUAL MODEL

Construction of a conceptual model of the ecosystem was one of the first tasks performed during

Table 2. Percent of Respondents Indicating a Preference for Various Data Presentation Techniques

Data presentation techniques	% of respondents indicating preference
Maps	88.9
Tables	75.0
Graphs	75.0
Narratives	69.4
Computer data tapes	33.3
Flow diagrams	27.8

the characterization of the Chenier Plain. The model identified, as accurately as possible, the system components and their functional interactions and regulatory processes. The initial model served as a guide for development of the characterization and identified the data that should be assembled and where the data would be applied in the characterization. In addition to functioning as a guide in the data collection effort, the model also assured what appropriate focus would be given to the various components of the ecosystem.

After the data was assembled, analyzed, and applied to the appropriate components, the resulting model served to identify data gaps and provided insight to areas requiring special attention.

The conceptual model of the Chenier Plain ecosystem characterization contained components, flows, structure, and external forcing functions and presented them in proper relationship. It further provided the organizational framework for development of the products of the characterization. Description, explanation, and prediction followed the outline of the conceptual model so that the ecosystem, its basins, habitats or communities, populations, and individuals could be elaborated more systematically in the characterization.

Data, flow diagrams, or other forms of information proposed for inclusion in the characterization were tested for (1) reliability; (2) clarity of content; (3) relevance, i.e., identifiability and specificity of the information, interaction, etc., and (4) redundancy. The conceptual model was also checked for organization and completeness.

The conceptual models for the other characterization studies have evolved from an initial guide to data collection and utilization, to a system of qualitative ecological modeling for user orientation. This approach includes modeling ecosystems by incorporating generalized energese diagrams with coincidental graphic displays that illustrate representational ecosystem cross sections and appropri-

ate floristic and faunistic characters. Thus each ecosystem is introduced by a combinatorial model merging classic Odum emergese symbolism with graphic (pictorial) presentations. This combination should give the wide range of user groups a maximum understanding of each ecosystem by stressing the identification of primary ecosystem components and the relationships between these components.

### AREA DELINEATION

The coastal zone in western Louisiana and eastern Texas is a large integrated system which developed during 7,000 years of deposition of riverine sediments, mostly from the Mississippi River, coupled with the continual erosion, sorting, reworking, and longshore transport of these sediments by marine forces. The entire system can be functionally divided into two broad zones, the eastern deltaic plain and the western Chenier Plain. The geological formation of the Chenier Plain was studied during the characterization of this area so it could be demonstrated that the entire region is a system, the parts of which are functionally connected by dynamic long-term physical processes.

During the characterization of the Chenier Plain ecosystem, it was appropriate to delineate the area into functional subsystems. A hierarchy of resolution was used; at the top is the entire Chenier Plain, which consists of a group of individual drainage basins, each of which is further subdivided into distinct regions (habitats) with characteristic organismal communities and physical components, and habitats that are further subdivided into individual species units (Table 3). Each higher level of resolution obviously includes more detail (complexity), although increasing the detail in a system model does not necessarily confer more understanding of the entire system.

As the level of resolution is increased to a small system, the time frame becomes shorter. For example, the entire Chenier Plain system evolved and is changing on a time scale of thousands of years, keyed to such geological processes as the periodic switching of the Mississippi River and eustatic (sea level) changes. Individual habitats, on the other hand, have been affected by annual cycles of solar energy flux, animal migrations, etc., and even were radically altered by such short-term events as storm surges and local "eat outs" by geese or muskrats.

Table 3. Units within the Chenier Plain Ecosystem Hierarchy

Basins	Habitats	Populations and/or species
Vermilion	Wetlands	Shrimp
Mermentau	Impounded areas	Menhaden
Chenier	Salt marsh	Finfish
Calcasieu	Brackish marsh	Oyster
Sabine	Intermediate marsh	Blue crab
East Bay	Fresh marsh	Crawfish
	Swamp forest	Clam
	Aquatic	Furbearers and other mammals
	Nearshore gulf	
	Inland open water	
	Ridges	Alligator and other reptiles
	Beach	Bullfrog
	Cheniers, natural levees, Pleistocene islands	Waterfowl and other birds
	Upland and manmade spoil areas	
	Agriculture	
	Rice and other crops	
	Pasture	
	Urban	

Each level of the hierarchy was set in a natural ecological context in the characterization in keeping with the following rationale:

1. The whole Chenier Plain region is unified by a common geological and climatic history that explains its origins.
2. The drainage basin is the wetland analog of the watershed, and it is the most nearly self-contained or autonomous ecosystem of the Chenier Plain. It is composed of a set of habitats or communities integrated by the flow of water through the basin.
3. "Habitats" or communities are not as sharply defined. A habitat refers to an organized unit that has characteristics in addition to its individual and population components and it functions as a unit through coupled metabolic transformations.
4. Populations of individual species are intuitively unique. The organisms have a common gene pool, and harvest statistics are usually reported by species. Individual species often occur in a number of different habitats.

This method for delineating study area is being used in some of the other characterization studies and provides the framework for understanding the functional relationships within an ecosystem. However, other methods are also being explored.

## LAND USE DATA AND TYPE MAPPING

Previous studies had proven the usefulness of remote sensing techniques for coastal mapping. They had also proven this tool to be cost-effective, efficient, and relatively accurate. The degree of accuracy, however, depended upon the resolution desired. Techniques tested in devising a methodology suitable for ecological characterization were Landsat imagery, black and white photographs, infrared imagery, aerial and ground observations, and various combinations of these.

Landsat imagery was tested with the most sophisticated equipment available at Bendix Corporation, Ann Arbor, Michigan and National Atmospheric and Space Administration, Slidell, Louisiana. Training sites were adequately identified by ground truth to identify spectral signatures displayed on Landsat imagery. Maps were quickly generated by this procedure in pilot study areas and quantitative data were displayed according to the frequency of various signatures.

Resolution appeared to be within acceptable limits. However, checks of the maps generated in this manner revealed that there was not always a distinct signature for each habitat; consequently, map displays sometimes differed significantly from actual conditions.

Coastal marshes make up a large portion of the Chenier Plain and they contain a wide array of plant species varying in composition, density, and growth stage. These differences could not be adequately categorized from Landsat scenes, as required for the characterization process.

The procedure that proved most desirable is similar to that currently used for the National Wetland Inventory being conducted by the Fish and Wildlife Service. This procedure requires a combination of data obtained from infrared imagery and other aerial surveys. Aerial surveys by persons able to identify plant types from low-level flights over the area are a strategic part of this type mapping. This procedure, coupled with land-use mapping from black and white photographs, produced data with accuracy satisfactory for characterization purposes. Also, this procedure proved to be more cost-effective than all other adequate procedures tested.

### PILOT STUDY

The overall objective of the pilot study was to gather sufficient information to develop a "mini-

atlas," which was used by project reviewers and others to evaluate a "finished" product with respect to the cost effectiveness of specific methods used, and the usefulness of the information to prospective users. In addition, it provided opportunities for the researchers to correct any misjudgments and possibly give insight to new methods. Data processing included investigation of data availability, collection, coding, analysis, and presentation. Data gaps were identified and filled where possible.

Criteria initially used for selection of the pilot study area included that the area be large enough and variable enough to be representative of the problems encountered over the entire Chenier Plain, and that previous investigations completed in the area would provide adequate background data for characterization. Those involved in the actual choosing of the site deemed that these criteria alone were insufficient to permit a final decision. Other criteria, therefore, had to be considered. In brief, some of these additional factors used were:

1. A representative display of habitats was located within the area.
2. A major urban complex was located within the basin.
3. Prevalence of petro-chemical industries.
4. Diversified fisheries and wildlife resources.

The pilot study concept proved to be an effective part of the characterization process. It met the primary objective of providing a preliminary format which could be reviewed and modified to maximize the effectiveness of the final product in meeting needs of user groups.

### CHARACTERIZATION STUDY

The general structure developed for the pilot study was used for the characterization atlas. This facilitated assessment and, to some degree, made known what could be expected in the final characterization atlas. Results were presented in several forms; maps, figures, tables. The written portion of the atlas was designed, to the extent possible, to stimulate the use of the material by resource managers.

Drafts of the atlas, maps, and other documents that are considered as the final products of the Ecological Characterization of the Chenier Plain are being reviewed and revised, and should be published during 1978.

# THE USE OF A PILOT STUDY IN DEFINING CHARACTERIZATION PROCEDURES AND PRODUCTS—COOS BAY, OREGON

Jay F. Watson,<sup>1</sup> Charles M. Proctor,<sup>2</sup> and Robert L. Holton<sup>3</sup>

## INTRODUCTION

In 1804, when Captains Meriweather Lewis and William Clark began their historic expedition to the Pacific Ocean, they carried with them an extraordinary document, a copy of President Thomas Jefferson's instructions to them (Cutright 1969). President Jefferson directed Lewis and Clark to observe:

. . . climate as characterized by the thermometer, by the proportion of rainy, cloudy, and clear days, by lightning, hail, snow, ice, by the access and recess of frost, by the winds prevailing at different seasons, the dates at which particular plants put forth or lose their flowers, or leaf, times of appearance of particular birds, or reptiles, or insects (Thwaites 1904).

Their expedition collected an incredible amount of information concerning botany, zoology, cartography, meteorology, and ethnology. Much of their information was collected at Fort Clatsop near the mouth of the Columbia River.

The U.S. Fish and Wildlife Service's (FWS) Pilot Study for the Ecological Characterization of the Pacific Northwest Coastal Region, although not of the historical significance of the Lewis and Clark expedition, has many similar characteristics.

The Service's study is a two-year effort. The Lewis and Clark expedition took two years and four months to complete. The expedition's encampment at Fort Clatsop was only part of their total project. The Pilot Study at Coos Bay is just a part of the total characterization process.

Secondly, the expedition's objective was to reach the Pacific Ocean. The FWS's objective is to characterize the Pacific Northwest coastal region from Cape Flattery, Washington, to Cape Mendocino, California. Their objective was approximately in the center of our study area.

Thirdly, it was hoped that the Lewis and Clark expedition would be the first of a continuing effort in the far west. The Pilot Study of Coos Bay is the first of 10 units in the process to characterize the Pacific Northwest coastal region.

Fourth, Captains Lewis and Clark were given a general set of instructions by President Jefferson with which to guide their data collecting efforts. The FWS contractor has also been given a general set of instructions to guide the characterization effort. History will have to tell us if the FWS writes instructions the way President Jefferson did.

And last, Lewis and Clark were directed to "characterize" the route they traveled, i.e., to pick out the significant things, the important items that separated one area from another. For example, while at Fort Clatsop, Lewis and Clark noted the dominant plants and animals. The characterization is also attempting to pick out or define the important features of the area.

As an additional comment, there is one major difference between the Lewis and Clark expedition and FWS effort. The Lewis and Clark expedition cost \$38,722.25 (Jackson 1977). The characterization study will cost approximately 12 times as much.

A characterization may be defined as: A study to obtain and synthesize available environmental data and provide an analysis of functional relationships and dynamics. The final products from a characterization will include: (1) a conceptual model, (2) a characterization atlas with narrative text, figures, tables, and charts, and (3) a data source appendix. An intermediate step in this process is a "Pilot Study" or test characterization which is the subject of this paper.

It is the mission of the FWS to conserve, protect, and enhance fish and wildlife and their habitat for the benefit of the people of the United States. In order to carry out this mission, the FWS is authorized or required, among other things, to conduct investigations, surveys, and research. An Ecological Characterization of the Pacific North-

<sup>1</sup>Fish and Wildlife Service, U.S. Dept. of the Interior, Portland, Ore. 97232.

<sup>2</sup>Ryckman, Ederly, Tomlinson, and Associates, Envirodyne Engineers, Bellevue, Wash.

<sup>3</sup>Dept. of Oceanography, Oregon State Univ., Corvallis, Ore.

west Coastal Region is one of the investigations that is being conducted to meet these responsibilities.

The study area, extending from Cape Flattery, Washington, to Cape Mendocino, California, and from the crest of the coast range to the 200-m contour line of the Pacific Ocean is an area of high fish and wildlife values. To help maintain these values the Service operates eight wildlife refuges along the California, Oregon, and Washington coast. These National Wildlife Refuges, including Oregon Island, Three Arch Rocks, Lewis and Clark, Columbia White-tailed Deer, Willapa, Copalis, Quillayute Needles, and Flattery Rocks, provide habitat for waterfowl, shorebirds, endangered species, and seabirds. In addition, the FWS is active in reviewing and commenting upon proposed activities that could cause adverse impacts upon fish and wildlife and their habitats in the coastal region. The FWS is also concerned about the possible impacts of energy development projects upon the area. These projects include foreign oil imports, Alaskan oil transshipment, liquified natural gas import, petrochemical industry development, and Outer Continental Shelf activities. The Coos Bay Unit was selected as a Pilot Study because it is representative of the area in habitat diversity, resources, and development.

The Coos Bay Unit includes all of the major components that were included in the first product of study, the conceptual model. The unit contains agricultural, recreational and commercial developments, logging, light industry, shipping, fisheries, and undeveloped areas. It was the opinion of the FWS and our contractor that the Coos Bay Unit would provide the kind of information and problems necessary to test the characterization process. The point of conducting the Pilot Study was to provide an example of the framework, data collection and coverage, map resolution, and synthesis of information that the contractor proposes to use in the final products. The success of this effort will probably not be fully apparent until the entire characterization is complete.

## METHODS

The Ecological Characterization of the Pacific Northwest Coastal Region is being conducted under contract by Ryckman, Edgerley, Tomlinson, and Associates, a St. Louis, Missouri, consulting firm with offices in Bellevue, Washington, and San Jose, California. They are being aided in the study by two subcontractors and several consultants. Dr.

Charles Proctor is the Project Manager, Mr. John Garcia is Technical Director, and Dr. Robert Holton is the Technical Coordinator for the Oregon area of the characterization. Dr. Jay Watson is Project Officer for the FWS.

For the Pilot Study, basic guidelines have been developed for the preparation of products. First, we have defined our user. It was stated early in the project that our target user was an FWS - Ecological Services field biologist.

Although we want the characterization to be aimed primarily at FWS biologists, the characterization must also be acceptable to a wide range of users. In an attempt to meet this guideline we have included and are continuing to include several Federal, State, and local agencies in the review process. In addition, we are attempting to provide enough information in the text so that anyone, given the time and interest, can understand all aspects of the characterization. For example, if we take a conceptual model of the external factors important in understanding an eelgrass (*Zostera* spp.) community, and present it without clearly developing an understanding of the energy-mass flow symbols used in the model, it is not of a great deal of use to our field biologists or other people who may wish to use the conceptual model. However, if we take the user through an exercise in using the various symbols, developing the vocabulary and syntax of this new language in a structured manner, then the conceptual model becomes a useful product. That is, if we move progressively through our conceptual model from a pictorial representation of a simplified hydrologic cycle to a general energy-mass flow diagram to a more detailed energy-mass flow diagram, we think the user can more easily understand the special language of the diagrammatic models of the ecosystems processes.

The conceptual model is used as a template or guide for data collection. The conceptual model was completed with the intention that it would lead to a structured collection and synthesis of existing information for the pilot study and the rest of the characterization. For example, there is a great deal of information available concerning the distribution of zinc in the lower Columbia River and Willapa Bay, Washington. However, all of the models to date seem to indicate that zinc distribution data are not a key factor in our understanding of the structure and function of coastal ecosystems. If we were not careful, however, we could have spent a great deal of time trying to work the zinc information into our analysis.



The text of the characterization, or in this case the text for the pilot study, is to start at the beginning or at some point near the beginning in our understanding of a particular process or system. Dr. Tim Joyner, a consultant on this project who is writing the section concerning geologic processes, located a discussion by William Maclure which seems to establish a base for further analysis. Maclure's observations (1817) seems to give us a starting point for our discussion of the geologic processes for the Coos Bay Pilot Study. Another starting point that was selected for the discussion of Trophic Structures was Lindeman's analysis of The Trophic-Dynamic Aspect of Ecology (Lindeman 1942).

Whether we like to admit it or not, most of the information transferred within the FWS and from the Service to other agencies is in black and white and reproduced on copying machines. Therefore, to obtain the greatest long-term use of the maps and other graphic materials being produced for the characterization, we are using black and white. The pilot study contains several different approaches to information presentation, and the reviewers are selecting the ones that they consider the most useful. Furthermore, we are attempting to avoid oversized documents by fitting most of our information on 8½-by-11-inch pages. A few foldout pages have been included, which are 11 by 17 inches.

One of the most perplexing problems in completing the pilot study of Coos Bay has been to match the depth or extent of information coverage with manpower. Actual data collection and analysis for the Coos Bay Watershed Unit (one of 10 units to be characterized) began on 1 June 1977, and was completed 4 months later on 30 September 1977. If 4 months are required for each watershed, we will not complete the project by the scheduled completion date of December 1978. However, we think that future units will be completed more rapidly because the conceptual model has been refined using actual data, the graphics and format will stabilize, and the amount of information required for each new unit will decrease as the project nears completion.

For example, the FWS is providing the wetland maps for the Pilot Study area and also for the entire characterization area. Our first efforts on the Coos Bay Unit took approximately 1.5 man-months to locate and delineate the wetlands found within the five quadrangle maps that make up the unit. The process of wetland mapping proceeds as follows:

1. Aerial photographs obtained;

2. Field reconnaissance of the study area completed;
3. Classification and delineation of wetlands completed according to the FWS Classification System; and
4. Field check sites as necessary.

During our initial effort on Coos Bay the photographs were delineated and then 17 sites were checked. One major problem was identified during these checks; mapping conventions must be well established. For example, originally the photointerpreters were using tidegates as the head of high tide. Ground checks indicated that about half of the tidegates were inoperable and that head of tide was actually further upstream. The mapping convention that was chosen to remedy this mapping problem was modified from a definition in Oregon Estuaries (Oregon Division of State Lands 1973). The head of tide, as we are defining it now, is a point of continuous diking along the river edge where the tideland narrows to a width of approximately 6 to 9 m (20 to 30 ft).

Now that the first set of wetland maps has been produced, we believe that the effort required for future mapping can be greatly reduced. Ground truth sites can probably be reduced from 17 to 10 or less and the final field checks eliminated entirely. We believe that the mapping effort will be 0.5 man-month per unit as opposed to 1.5 man-months required for the Coos Bay Unit.

## CONCLUSION

What have we learned from the Pilot Study of Coos Bay, Oregon? Although we have just completed the pilot study, it appears that:

1. The conceptual model is a suitable framework for data collection;
2. The contractor has adequate manpower to complete the characterization on schedule;
3. The depth of coverage is sufficient for an understanding of functional relationships and dynamics of the processes described in the characterization; and
4. The amount of information collected is not so extensive that it cannot be synthesized into a comprehensible document.

However, there are also some problems that have been identified during the pilot study. One of the most persistent problems is showing the relationship between natural resources and socioeconomic processes. We are having difficulty showing

just how natural resource utilization relates to socioeconomic processes. For example, if we are managing our natural resources effectively, our economic activity should be dictated by the resources available. If on the other hand, we cannot identify important processes or the levels of resources available, then economic activity is probably dictating the rate of utilization. That is, are we cutting trees faster than we are growing them? In any event, the information contained in the conceptual model and the pilot study does not clearly show the relationship between man's activities and the natural resource base. It is hoped that during the course of this project we will be able to improve our understanding of this relationship.

Another problem that has become apparent involves the various ecosystem models. For example, the different systems vary with high and low tides, night and day, summer and winter, and high and low flows. We are looking over various options that could be used to modify the models to show these variations.

#### REFERENCES

- Cutright, P. R. 1969. Lewis and Clark: Pioneering naturalists. University of Illinois Press, Urbana. 506 pp.
- Jackson, D., ed. 1977. Letters of the Lewis and Clark expedition with related documents, 1783-1854. University of Illinois Press, Urbana (cited in Cutright, 1969).
- Lindeman, R. L. 1942. The trophic-dynamic aspect of ecology. *Ecology* 23:399-418.
- Maclure, W. 1817. Observations on the geology of the United States of America with some remarks on the nature and fertility of soils by the decomposition of the different classes of rocks; and an application to the fertility of every state in the Union in reference to accompanying geologic map. Read as a memoir before the Am. Philos. Soc. and inserted in the first volume of their Transactions, New Series-Philadelphia.
- Oregon Division of State Lands. 1973. Oregon estuaries, Portland, Oregon. n.p.
- Thwaites, R. G., ed. 1904-5. Original journals of the Lewis and Clark expedition. Dodd, Mead and Co. New York. 8 vols (cited in Cutright, 1969).

**USER-ORIENTED CONCEPTUAL MODELING IN  
THE ECOLOGICAL CHARACTERIZATION OF THE SEA ISLANDS  
AND COASTAL PLAIN OF SOUTH CAROLINA AND GEORGIA**

John J. Manzi<sup>1</sup> and Robert J. Reimold<sup>2</sup>

**INTRODUCTION**

The Division of Marine Resources, South Carolina Wildlife and Marine Resources Department, began work in February 1977 on an ecological characterization of the sea islands and coastal areas of South Carolina and Georgia. This work is under contract to the U.S. Fish and Wildlife Service and has as its principal goal "a description of the important components and processes comprising (sea island) ecosystems and an understanding of their important functional relationships" (Palmisano, 1978). The final products of the characterization include (1) a conceptual model which identifies system components and their interactions; (2) a characterization atlas which illustrates through graphs, pictorials, tables, and maps the socioeconomic, physical, and biological aspects of the study area; (3) a characterization narrative and bibliography which summarizes available published and unpublished data on the study area; and (4) a data appendix containing unpublished data used in the characterization effort (U.S. Department of the Interior, Fish and Wildlife Service, RFP FWS-8-206, 25 June 1976). These products should provide essential information to decisionmakers concerning proposed or existing perturbations in the coastal areas of South Carolina and Georgia. In addition, the characterization should also indicate where serious data gaps exist and perhaps place priorities on the direction of future research.

The conceptual model, as originally outlined by the U.S. Fish and Wildlife Service (RFP FWS-8-206), was to function primarily as an instrument to assist in collection and organization of data. In this context, the model would form a framework of the coastal ecosystems indicating principal components and the relationships between them. The model would then act as a guide to project partici-

pants in their individual assignments and thus provide the cohesion necessary to produce a uniform and consistent characterization. In practice, the conceptual model for the ecological characterization of the coastal areas of South Carolina and Georgia has evolved into a user-oriented-(rather than producer-oriented) guide to the coastal ecosystems characterization products (narrative, atlas, and data appendix). The present paper traces this evolution and describes the model/user package concept adopted for the sea island characterization project.

**CONCEPTUAL MODELING—  
INITIAL PROPOSAL**

In August 1976, the Division of Marine Resources, South Carolina Wildlife and Marine Resources Department, responded to RFP FWS-8-206 with a proposal to develop a comprehensive ecological characterization of the sea islands and coastal plain of South Carolina and Georgia. In this document we proposed a schedule of ecosystem modeling strongly based in systems analysis (Dale 1970). The model we initially proposed to develop was to serve four primary functions: (1) orderly accumulation of knowledge about the ecosystem; (2) synthesis of this knowledge into functional relationships; (3) definition of areas in need of further study; and (4) systems analysis for planning and management of resource utilization and conservation. Thus, it would indicate what data are to be collected and where they would be used in the actual characterization.

The model was to be characterized by four basic elements: compartments, flows between entities, major inputs or external driving forces, and major outputs or products. The compartments would identify major entities and sets within entities. In principal subsystems, the compartments would identify habitats and then major storage areas (biotic and abiotic) within the subsystems. Major driving forces (inputs) and products (outputs)

<sup>1</sup>Marine Resources Research Institute, Charleston, S.C. 29412

<sup>2</sup>Georgia Department of Natural Resources, Brunswick, Ga. 31520

would be used to balance flows within the model and to identify primary areas of concern for management and development activities.

We proposed to illustrate the model with Forrester Diagrams, following the pattern adapted by the IDOE-CITRE group in their proposal (1972). The units of the compartments and flows would change in relationship to the subsystem under study, i.e.,  $gC/m^2$  for energy flows,  $mg/m^2/yr$  for nutrient flows, etc. Because the Forrester Diagrams (Forrester 1961) would quickly become unmanageable in an ecosystem as complex as sea islands, each set within each subsystem was to be treated independently. The subsystems would then be abbreviated when combined to form the principal model. It would thus be possible to maintain a manageable matrix for the ecosystem model as a whole and still have high resolution as each major entity is encountered.

In practice, the major entities (habitats) incorporated into the sea island ecosystem model would include, but not be limited to, the following: off-shore euhaline, inshore euhaline, ocean beach (including shifting dunes), stable dunes, maritime forest, pine forest, coastal plain, marsh (including tidal creeks, river beaches, mud flats, freshwater marsh, brackish water marsh, salt marsh, high marsh, low marsh, marsh impoundments), freshwater, and estuary. Within each subsystem the principal physical, chemical, geological, and biological entities would be compartmentalized. For example, in modeling the chemical processes of an estuary, the important variables would include salinity (as an index of mixing and a habitat determinant), temperature, concentration of dissolved oxygen, pH, alkalinity, concentrations of organic materials (dissolved and particulate), nutrient levels, concentrations of certain metals, etc. Biological modeling within subsystems such as estuaries would not proceed to the individual species level but would deal with spatial variation as distributed sources and sinks (Nihoul 1975). Biological subsystems would be comprehensively resolved into component biotic subsets (e.g., phytoplankton, zooplankton, nekton, benthos, etc.) and linked through major variables (nutrients, carbon, etc.) within the system. In addition, external driving forces (temperature, salinity, light, allochthonous materials, etc.) for each subset, and export links to other subsets or subsystems, would be identified. The final model was envisioned as a block diagram with blocks representing the major components and lines indicating flows (of carbon,

energy, etc.) from one component to another and the relationships between subsystems (Patten 1971; Odum and Odum 1972).

## CONCEPTUAL MODELING— INTERIM PROCEDURE

The above protocol for conceptual modeling was initiated in February 1977. However, we quickly found that these models actually had only narrow application to the project. Also, it became apparent that the list of major entities (habitats) to be incorporated into the ecosystem model would have to be revised. The revision was accomplished by using a synthesis of aquatic and terrestrial terminology and the U.S. Fish and Wildlife Service's Interim Classification of Wetlands and Aquatic Habitats of the United States (Cowardin et al. 1976). This synthesis resulted in the identification of seven primary systems (marine, estuarine, riverine, palustrine, lacustrine, maritime, and upland) to be modeled encompassing a total of 32 major subsystems (fig. 1). Various subsystems will also be modeled. The ecosystem models were to be used to identify system components and to structure them into an expanded subject outline for the characterization.

The value of the conceptual model in relating functional interactions and regulatory processes, as well as identifying system components, prompted us to pursue models which could be integrated with the characterization atlas and narrative. There the models would present a preface summary of each ecosystem and also function as a user tool in understanding the impact of impingements or perturbations on system components. To perform as part of a user package, the complexity of the master models would often be dissected into subsystem models or submodels. Submodels are generally divided into four formats:

1. Terrestrial or hydrological submodels (soil types, elevation, wind, wave action, currents, tidal action, dispersed, diffusion, etc.);
2. Environmental quality submodels (physical states, chemistry, etc.);
3. Microbiological submodels (viruses, bacteria, fungi, microscopic algae, and invertebrates); and
4. Macrobiological submodels (macroscopic plants and animals, population dynamics, etc.). These submodels are rarely indepen-

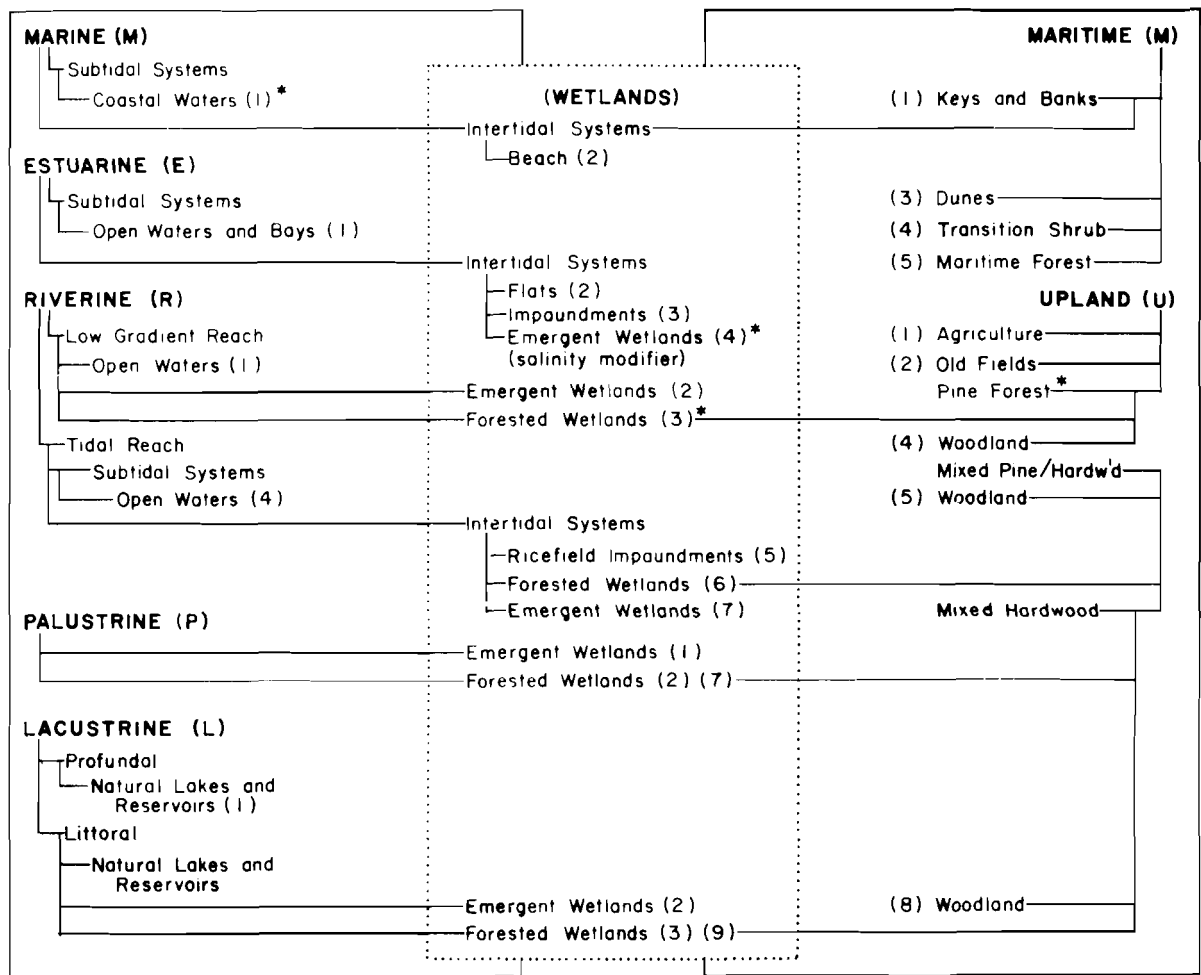

- \*AM1000 Marine Subtidal Systems Coastal Waters
- AM2000 Marine Intertidal Systems Beach
- AE1000 Estuarine Subtidal Systems Open Waters & Bays
- AE2000 Estuarine Intertidal Systems Flats
- AE3000 Estuarine Intertidal Systems Impoundments
- \*AE4000 Estuarine Intertidal Systems Emergent Wetlands (Salinity Modifier)
- AR1000 Riverine Low Gradient
- AR2000 Riverine Low Gradient Emergent Wetlands
- \*AR3000 Riverine Low Gradient Forested Wetlands
- AR4000 Riverine Tidal Reach Subtidal Systems Open Waters
- AR5000 Riverine Tidal Reach Intertidal Systems Ricefield Impoundments
- AR6000 Riverine Tidal Reach Intertidal Systems Forested Wetlands
- AR7000 Riverine Tidal Reach Intertidal Systems Emergent Wetlands
- AP1000 Palustrine Emergent Wetlands
- AP2000 Palustrine Forested Wetlands

\*Models selected for Santee test characterization.

- AL1000 Lacustrine Profundal Natural Lakes and Reservoirs
- AL2000 Lacustrine Littoral Emergent Wetlands
- AL3000 Lacustrine Littoral Forested Wetlands
- TM1000 Maritime Keys & Banks
- TM2000 Maritime Keys & Banks Beach
- TM3000 Maritime Dunes
- TM4000 Maritime Transition Shrub
- TM5000 Maritime Forest
- TU1000 Upland Agriculture
- TU2000 Upland Oil Field
- TU3000 Upland Pine Forested Wetland
- \*TU4000 Upland Pine Forest
- TU5000 Upland Mixed Pine/Hardwood Forest
- TU6000 Upland Mixed Pine/Hardwood Forested Wetland
- TU7000 Upland Mixed Hardwood Forested Wetland
- TU8000 Upland Mixed Hardwood Forest
- TU9000 Upland Mixed Hardwood Forested Wetland

Figure 1. Master models -- Sea Island Characterization

dent and often overlap or partially fuse. The relative importance of each submodel within the ecosystem model is, of course, variable among ecosystems. In aquatic and wetland ecosystems this submodel interdependency is epitomized (Hansen 1975), and submodels of major ecosystems have metamorphosed into integrated subsystem models.

Modeling biological systems or attempting biological simulation has evolved into the conceptualization of biological components and processes against a background of physical and chemical variables. Such models are often considered to belong to one or more of the following hierarchical classifications:

1. Ecosystem models;
2. Productivity models;
3. Population models; and
4. Process models.

These are listed more or less in order of decreasing complexity, but no hard and fast definitions are possible. In our attempt to provide conceptual modeling to a user package, the master models (fig. 1) probably best demonstrate the ecosystem/process model approach while submodels are more often population/process model oriented.

The following display illustrates how we expected the conceptual models to function in the user package. Figure 2 is master model AE4 (fig. 1), a simplified ecological/process model of an estuarine intertidal system—emergent wetland with salinity modifiers (i.e., salt and brackish marsh). It is this model to which the user is first directed in order to convey the physical, chemical, and biological interactions and the primary driving forces. This model is further dissected into component system submodels: figure 3, AE41 (marsh); figure 4, AE42 (water); and figure 5, AE43 (sediment). The user can refer to the appropriate submodel for specific information on master model components. For example, if the user is interested in evaluating the impact of dredge-and-fill operations in an estuarine emergent wetland, he is directed by the master model to the marsh and water submodel primary producer components. All compartments in the submodels are numbered (01-99) and specific organisms can be identified as components by their associated alphanumeric code (see submodels for specific examples). Ecologically and/or numerically important species could be identified by this code in the characterization narrative and atlas.

The interim procedure described above, while attractive in theory, was extremely cumbersome to use. The total number of master models and submodels needed for the entire study area would have amounted to well over 100 and the technique for referencing key species into the models would have resulted in thousands of manhours for citation and annotation in the other characterization products. In addition, the interim procedure did little to communicate the contents of the characterization products to primary users (i.e., field biologists).

The present approach attempts to provide a user-oriented system of access to product information as well as an ecological understanding of the various habitats comprising the study area. The modeling effort has been altered appreciably to enhance the value of the models as primary components of a “user package.” The materials contained in this “package” are assembled to supplement and provide rational entry into the principal products of the characterization project (i.e., narrative, atlas, data appendix, and bibliography). The package is a user guide and is composed of four major parts: an executive summary, models, habitat distribution of various species, and interaction matrices. The executive summary will provide an introduction to characterization concepts, a brief summary of the sea island ecosystems and general instructions for using the package components for data search and retrieval. Models are included to acquaint the reader with the principal components of each ecosystem and the extrinsic forces and intrinsic relationships associated with these components. The models are presented in a diagrammatic (energes) and a pictorial mode, hence combinatorial. The ecological sketches are brief narratives on “high priority” species, and summarize their reproductive and cover requirements, and impinging human activities. Finally, the interaction matrices will form the central component of the user package. Each ecosystem will be supported by a single matrix which cross-references common environmental alterations with existing environmental characteristics. Each intersection of the matrix will thus provide appropriate entry into the characterization products.

The functional components of the user package are the combinatorial models, ecological sketches, and the interaction matrices. The combinatorial

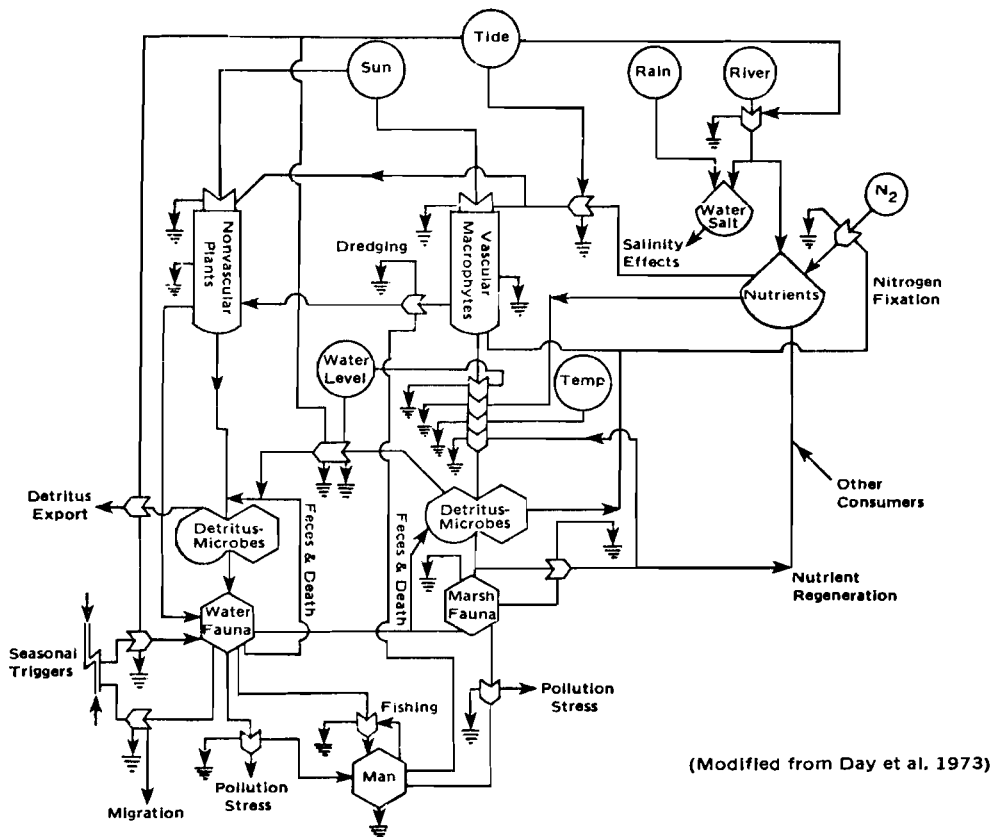

Figure 2. Master Model AE 4000: estuarine intertidal system—emergent wetland (salinity modifier)

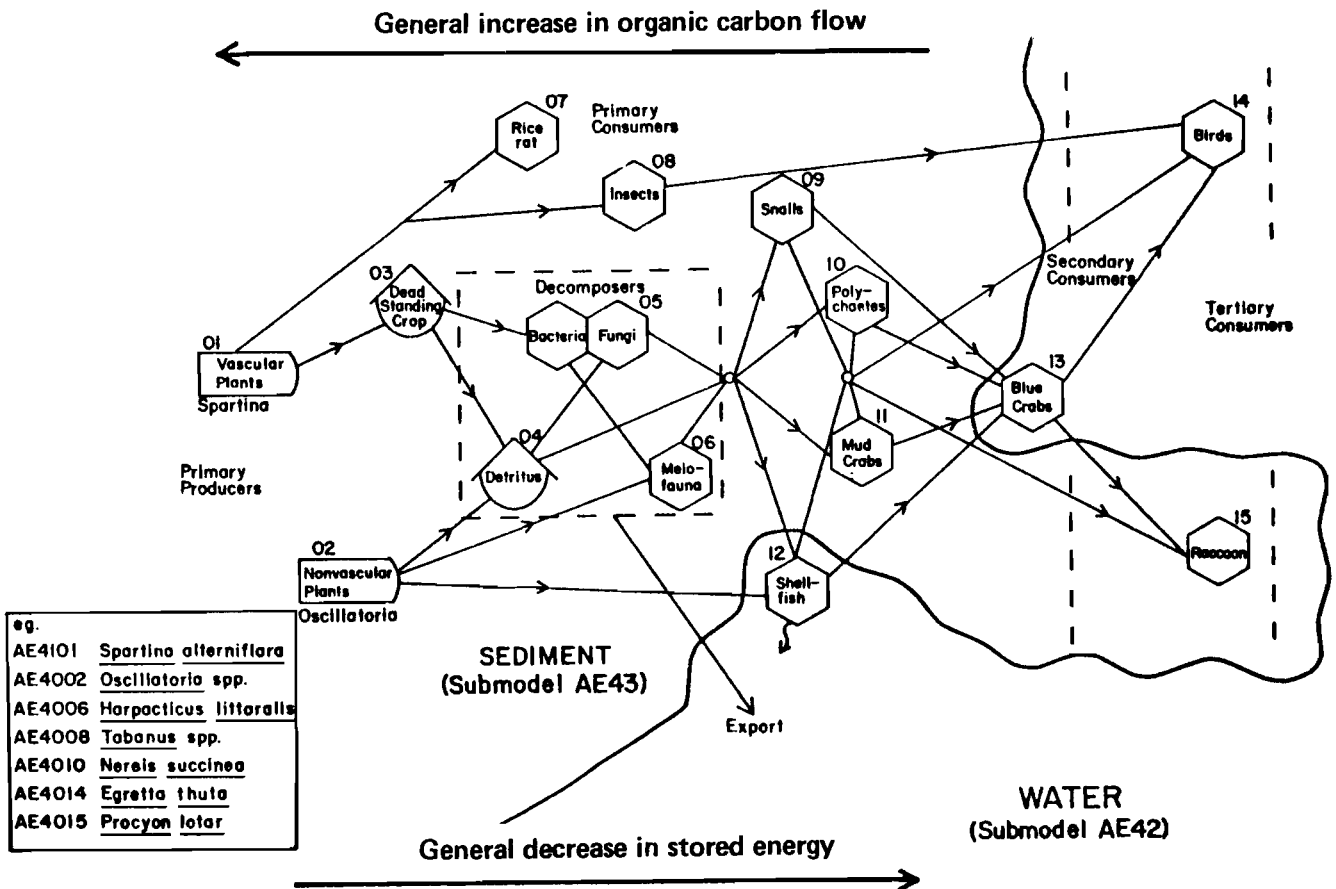

Figure 3. Submodel AE41: estuarine intertidal emergent wetland—marsh

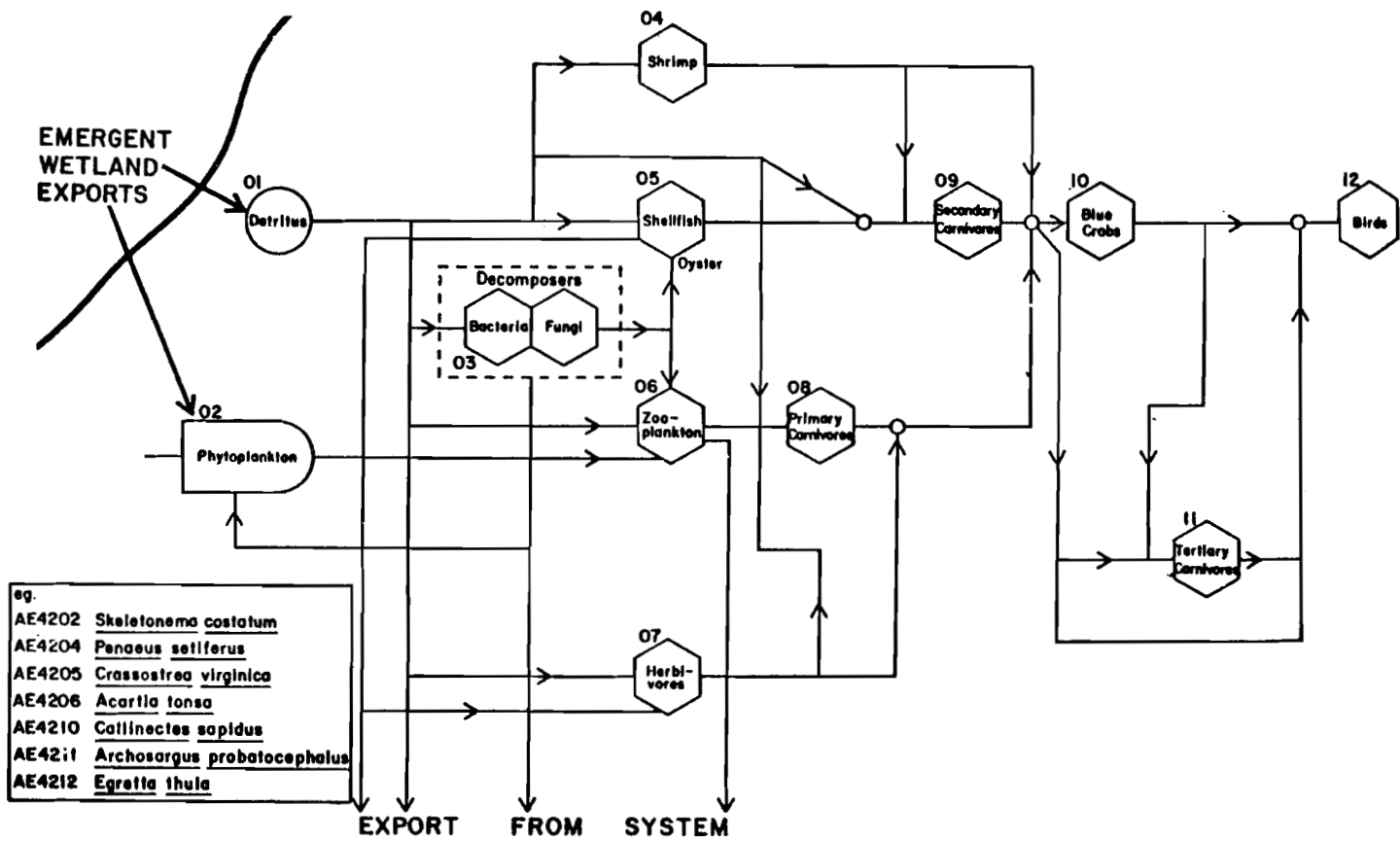

Figure 4. Submodel AE42: estuarine intertidal system -- water

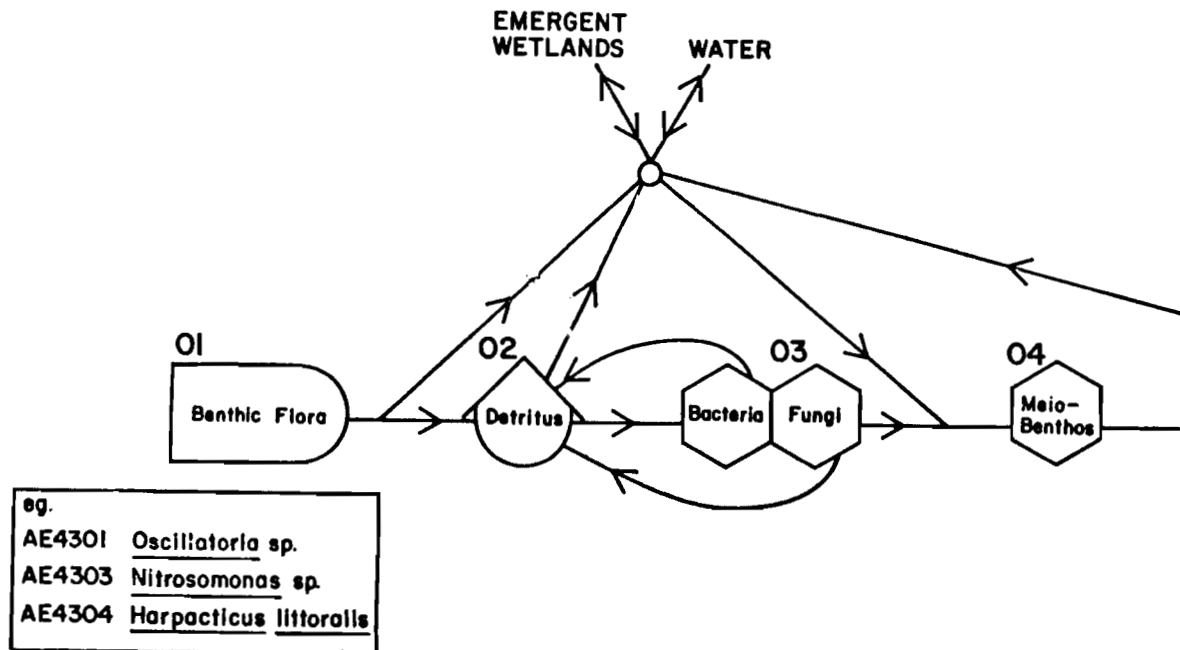

Figure 5. Submodel AE43: estuarine intertidal emergent wetland -- sediment



models for the entire characterization are listed in figure 1. The four models compiled to date for the Santee Test Characterization Area (fig. 1) are: the marine subtidal system, the estuarine intertidal emergent wetland system (fig. 6), the riverine forested wetland system, and the upland pine forest system. The user would first be directed to these and should pursue the appropriate model(s) for the system(s) in question. Each system is displayed in dual form: an energy diagram showing energy flow into the system, interrelationships between components of the system, and flow from the system (fig. 6), and an accompanying pictorial or pictograph (fig. 7) illustrating representative flora and fauna tagged with appropriate producer or consumer symbols. The user should examine the model to either reaffirm presumptive relationships or establish initial relationships.

At this time, the user may also wish to review species abundance and distribution charts if his/her interests encompass or center on a specific group or individual organisms. These charts are arranged taxonomically and each is composed of representative species from the group. The reader may now return to the models, or advance to the characterization products through the interaction matrices.

The matrices provide points of entry to the characterization products based on specific interests of the reader. A customized matrix (e.g., fig. 8) is constructed for each ecosystem modeled and presents intersections between primary existing environmental characteristics and proposed environmental alterations. Each intersection will provide a coded entry (blanks will indicate data gaps and an "x" will indicate an inappropriate interaction) to the characterization narrative and atlas, and back references to the models and ecological sketches. The narrative, atlas, and sketches will, in turn, provide entry to the data appendix and bibliography. In plan, the system should function as illustrated in figure 9. The matrix is the central reference, keying to, and being keyed from, all other products of the characterization. In combination, the models, ecological sketches, and interaction matrices should reveal to the reader ramifications and relationships that are not at first apparent. They should also allow full utilization of the characterization products by a wide spectrum of users with diverse educational backgrounds, interests, and needs.

#### ACKNOWLEDGEMENTS

We thank Mr. John Miglarese for his valuable assistance in planning the user package concept and

organizing the package materials. We also thank Drs. Lee Barclay and Paul Sandifer for reviewing the manuscript, Ms. Jane Davis, Karen Swanson, and Rose Smith for preparing the figures, Mr. David Chamberlain for constructing the ecological sketches, and Ms. Mary Anne Carson for preparation of the typescript.

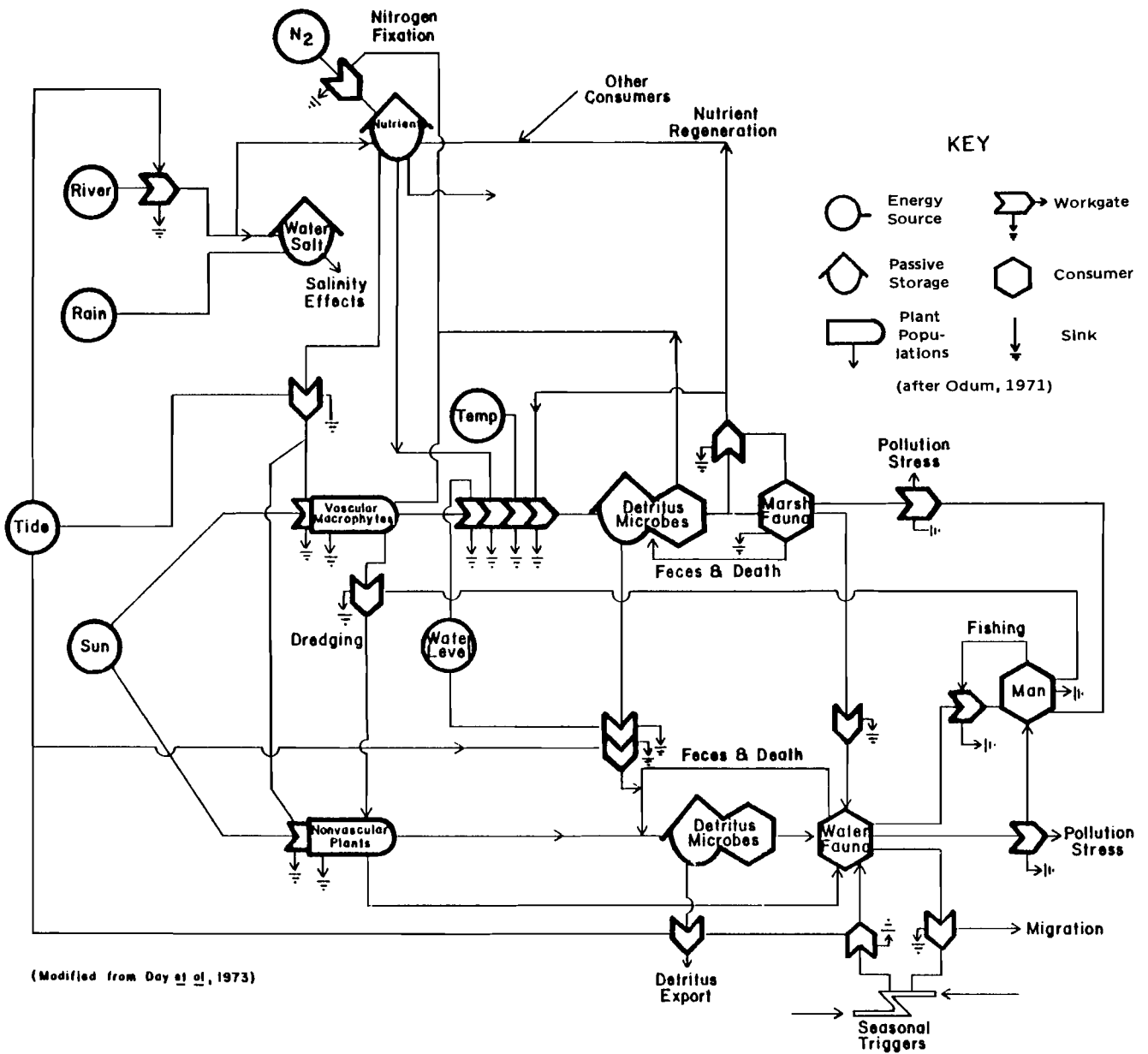

Figure 6. Master model AE4000: estuarine intertidal system -- emergent wetland (salinity modifier)

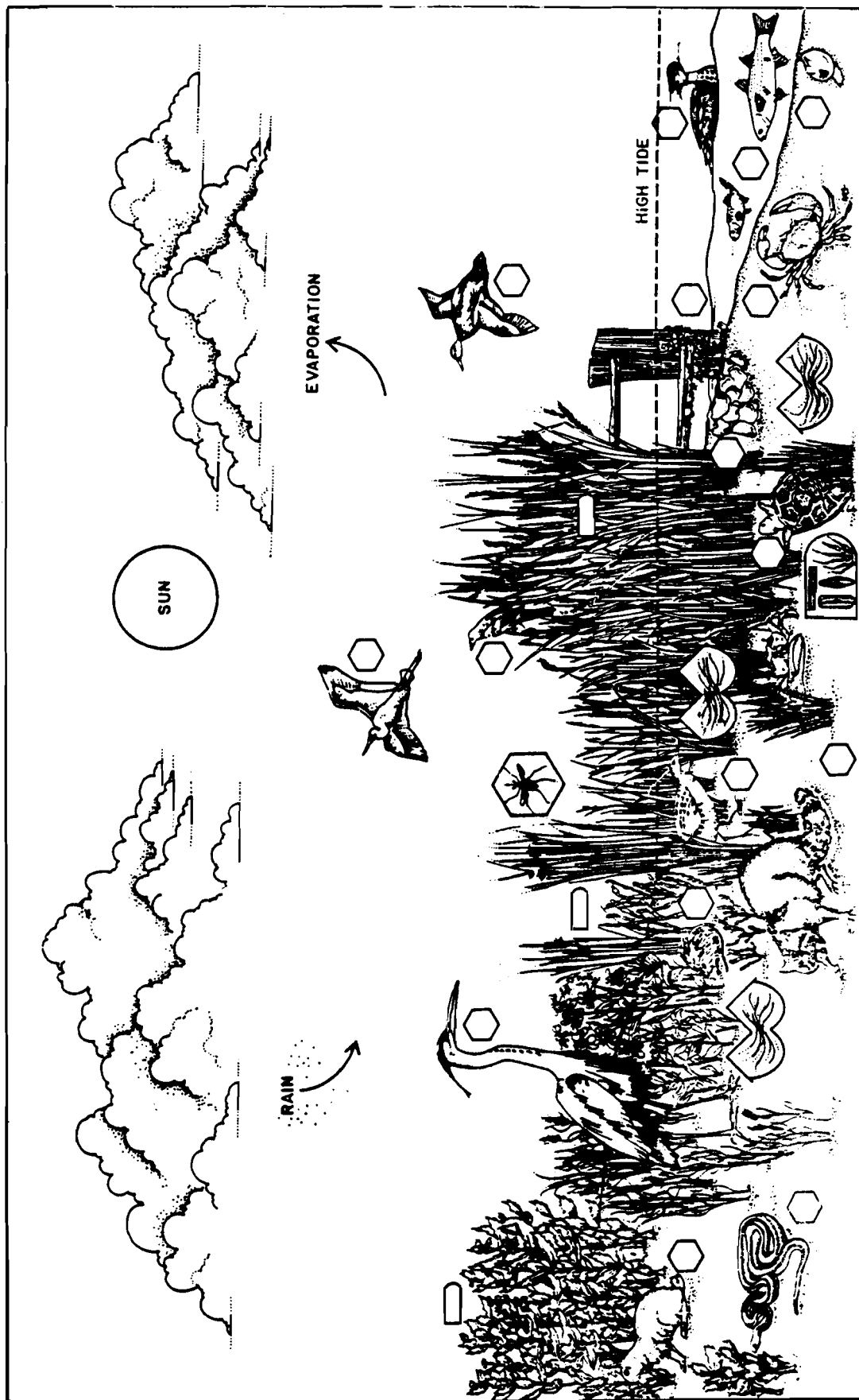

Figure 7. Representative flora and fauna — estuarine intertidal emergent wetland — pictorial (see Master Model AE4000)

ESTUARINE INTERSTITIAL EMERGENT WETLAND	PROPOSED ENVIRONMENTAL ALTERATIONS		MODIFICATION OF REGIME	TRANSFORMATION and CONSTRUCTION	RESOURCE EXTRACTION	PROCESSING	LAND ALTERATION	TRAFFIC	WASTE EMPLACEMENT	ACCIDENTS
	SOILS	WATER								
EXISTING ENVIRONMENTAL CHARACTERISTICS	CONSTRUCTION		1							
	MINERAL RESOURCES		2							
	METALS & HYDROCARBONS		3							
	TIDES & CURRENTS		4							
	WAVE ACTION		5							
	SALINITY		6							
	TEMPERATURE		7							
	NUTRIENTS		8							
	SESTON		9							
	UNIQUE PHYSICAL FEATURES		10							
PHYSICAL & CHEMICAL	GASES		11							
	PARTICULATE		12							
	MICROCLIMATE		13							
	MACROCLIMATE		14							
	FLOODS		15							
	EROSION		16							
	DEPOSITION		17							
	SOLUTION		18							
	STABILITY		19							
	STRESS		20							
BIOLOGICAL FACTORS	NONVASCULAR PLANTS		21							
	VASCULAR PLANTS		22							
	BACTERIA & FUNGI		23							
	DETRITUS		24							
	ZOOPLANKTON		25							
	INFAUNA		26							
	EPIFAUNA		27							
	FISH		28							
	REPTILES		29							
	BIRDS		30							
PAUNA	MAMMALS		31							
	AMPHIBIANS		32							
	INSECTS		33							
	PLANTS		34							
	ANIMALS		35							
	PLANTS		36							
	ANIMALS		37							
	PLANTS		38							
	ANIMALS		39							
	PLANTS		40							
ENVIRONMENTAL ALTERATIONS	SURFACE PAVING		41							
	BURNING		42							
	IRRIGATION		43							
	CHANNELIZATION		44							
	FLOW MODIFICATION		45							
	DRAINAGE ALTERATION		46							
	ALTERATION OF GROUND WATER		47							
	BIOLOGICAL CONTROLS		48							
	INTRODUCTION OF EXOTICS		49							
	COUSE		50							
TRANSFORMATION and CONSTRUCTION	SURFACE PAVING		51							
	BURNING		52							
	IRRIGATION		53							
	CHANNELIZATION		54							
	FLOW MODIFICATION		55							
	DRAINAGE ALTERATION		56							
	ALTERATION OF GROUND WATER		57							
	BIOLOGICAL CONTROLS		58							
	INTRODUCTION OF EXOTICS		59							
	COUSE		60							
RESOURCE EXTRACTION	SURFACE PAVING		61							
	BURNING		62							
	IRRIGATION		63							
	CHANNELIZATION		64							
	FLOW MODIFICATION		65							
	DRAINAGE ALTERATION		66							
	ALTERATION OF GROUND WATER		67							
	BIOLOGICAL CONTROLS		68							
	INTRODUCTION OF EXOTICS		69							
	COUSE		70							
PROCESSING	SURFACE PAVING		71							
	BURNING		72							
	IRRIGATION		73							
	CHANNELIZATION		74							
	FLOW MODIFICATION		75							
	DRAINAGE ALTERATION		76							
	ALTERATION OF GROUND WATER		77							
	BIOLOGICAL CONTROLS		78							
	INTRODUCTION OF EXOTICS		79							
	COUSE		80							
LAND ALTERATION	SURFACE PAVING		81							
	BURNING		82							
	IRRIGATION		83							
	CHANNELIZATION		84							
	FLOW MODIFICATION		85							
	DRAINAGE ALTERATION		86							
	ALTERATION OF GROUND WATER		87							
	BIOLOGICAL CONTROLS		88							
	INTRODUCTION OF EXOTICS		89							
	COUSE		90							
TRAFFIC	SURFACE PAVING		91							
	BURNING		92							
	IRRIGATION		93							
	CHANNELIZATION		94							
	FLOW MODIFICATION		95							
	DRAINAGE ALTERATION		96							
	ALTERATION OF GROUND WATER		97							
	BIOLOGICAL CONTROLS		98							
	INTRODUCTION OF EXOTICS		99							
	COUSE		100							
WASTE EMPLACEMENT	SURFACE PAVING		101							
	BURNING		102							
	IRRIGATION		103							
	CHANNELIZATION		104							
	FLOW MODIFICATION		105							
	DRAINAGE ALTERATION		106							
	ALTERATION OF GROUND WATER		107							
	BIOLOGICAL CONTROLS		108							
	INTRODUCTION OF EXOTICS		109							
	COUSE		110							
ACCIDENTS	SURFACE PAVING		111							
	BURNING		112							
	IRRIGATION		113							
	CHANNELIZATION		114							
	FLOW MODIFICATION		115							
	DRAINAGE ALTERATION		116							
	ALTERATION OF GROUND WATER		117							
	BIOLOGICAL CONTROLS		118							
	INTRODUCTION OF EXOTICS		119							
	COUSE		120							

Figure 8. Estuarine intertidal emergent wetland interaction matrix (sheet 1 of 2)

CULTURAL FACTORS	MODIFICATION OF REGIME										TRANSFORMATION and CONSTRUCTION										RESOURCE EXTRACTION										PROCESSING										LAND ALTERATION										TRAFFIC										WASTE EMPACEMENT										ACCIDENTS									
	1	2	3	4	5	6	7	8	9	10	11	12	13	14	15	16	17	18	19	20	21	22	23	24	25	26	27	28	29	30	31	32	33	34	35	36	37	38	39	40	41	42	43	44	45	46	47	48	49	50	51	52	53	54	55	56	57	58	59	60	61	62	63	64	65	66	67	68	69	70	71	72	73	74	75	76	77	78	79	80
ECOLOGICAL RELATIONSHIPS	1	2	3	4	5	6	7	8	9	10	11	12	13	14	15	16	17	18	19	20	21	22	23	24	25	26	27	28	29	30	31	32	33	34	35	36	37	38	39	40	41	42	43	44	45	46	47	48	49	50	51	52	53	54	55	56	57	58	59	60	61	62	63	64	65	66	67	68	69	70	71	72	73	74	75	76	77	78	79	80
MAN-MADE STRUCTURES	1	2	3	4	5	6	7	8	9	10	11	12	13	14	15	16	17	18	19	20	21	22	23	24	25	26	27	28	29	30	31	32	33	34	35	36	37	38	39	40	41	42	43	44	45	46	47	48	49	50	51	52	53	54	55	56	57	58	59	60	61	62	63	64	65	66	67	68	69	70	71	72	73	74	75	76	77	78	79	80
RECREATION	1	2	3	4	5	6	7	8	9	10	11	12	13	14	15	16	17	18	19	20	21	22	23	24	25	26	27	28	29	30	31	32	33	34	35	36	37	38	39	40	41	42	43	44	45	46	47	48	49	50	51	52	53	54	55	56	57	58	59	60	61	62	63	64	65	66	67	68	69	70	71	72	73	74	75	76	77	78	79	80
LAND USE	1	2	3	4	5	6	7	8	9	10	11	12	13	14	15	16	17	18	19	20	21	22	23	24	25	26	27	28	29	30	31	32	33	34	35	36	37	38	39	40	41	42	43	44	45	46	47	48	49	50	51	52	53	54	55	56	57	58	59	60	61	62	63	64	65	66	67	68	69	70	71	72	73	74	75	76	77	78	79	80
EXISTING ENVIRONMENTAL CHARACTERISTICS	1	2	3	4	5	6	7	8	9	10	11	12	13	14	15	16	17	18	19	20	21	22	23	24	25	26	27	28	29	30	31	32	33	34	35	36	37	38	39	40	41	42	43	44	45	46	47	48	49	50	51	52	53	54	55	56	57	58	59	60	61	62	63	64	65	66	67	68	69	70	71	72	73	74	75	76	77	78	79	80
PROPOSED ENVIRONMENTAL ALTERATIONS	1	2	3	4	5	6	7	8	9	10	11	12	13	14	15	16	17	18	19	20	21	22	23	24	25	26	27	28	29	30	31	32	33	34	35	36	37	38	39	40	41	42	43	44	45	46	47	48	49	50	51	52	53	54	55	56	57	58	59	60	61	62	63	64	65	66	67	68	69	70	71	72	73	74	75	76	77	78	79	80

Figure 8. Estuarine intertidal emergent wetland interaction matrix (sheet 2 of 2)

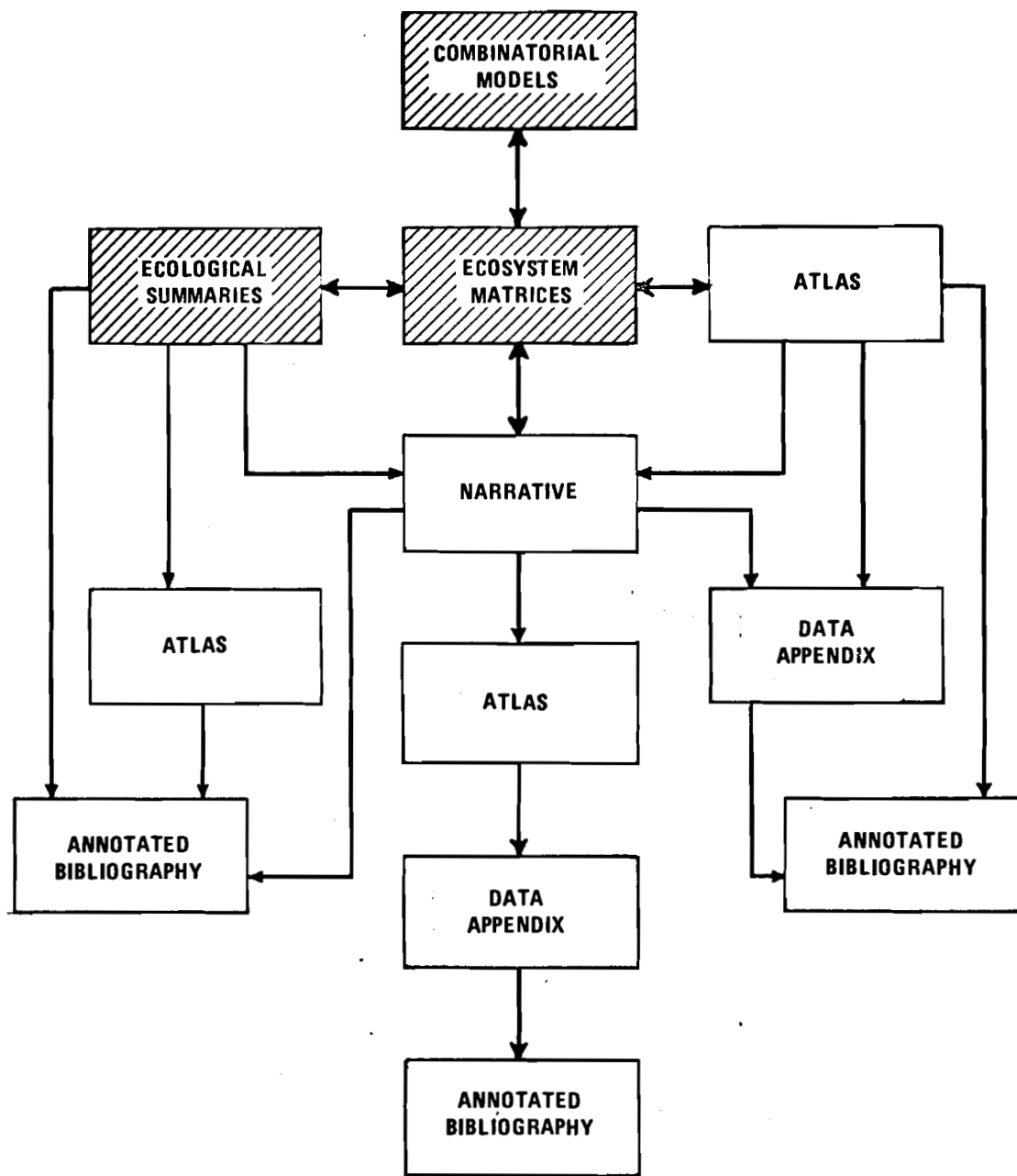

Figure 9. Flow diagram for user orientation to characterization products.

## LITERATURE CITED

- Cowardin, L. M., V. Carter, F. C. Golet, and E. T. LaRoe. 1976. Interim classification of wetlands and aquatic habitats of the United States. U.S. Fish and Wildlife Service. 109 pp.
- Dale, M. B. 1970. Systems analysis and ecology. *Ecology* 51(1): 1-16.
- Day, J. W., W. G. Smith, P. R. Wagner and W. C. Stowe. 1973. Community structure and carbon budget of a salt marsh and shallow bay estuarine system in Louisiana. Center for Wetland Resources, Publ. LSU-SG-72-04.
- Forrester, J. W. 1961. Industrial dynamics. MIT Press, Cambridge, Massachusetts. 464 pp.
- Hansen, J. 1975. Aquatic ecosystem analysis and modeling. A Sea Grant perspective. The Oceanic Institute, Waimanalo, Hawaii.
- IDOE-CITRE Group. 1972. International decade of ocean exploration: a proposal for comparative investigations of tropical reef ecosystems.
- Nihoul, J. C. J.; ed. 1975. Modeling of marine systems. Elsevier Scientific Publ. Co., Amsterdam, the Netherlands. 272 pp.
- Odum, E. P., and H. T. Odum. 1972. Natural areas as necessary components of man's total environment. *Trans. N. Am. Wildl. and Nat. Resour. Conf.* 27: 178-179.
- Palmisano, A. W. 1978. Ecosystem characterization—an approach to coastal natural resources planning and management. *In*: Proc. of a Contributed Session on Coastal Ecosystem Characterization and Management—Fourth Biennial International Estuarine Research Conference, Mt. Pocono, Penn. 2-5 Oct. 1977. U.S. Fish and Wildlife Service—Office of Biol. Serv. Publ. 77-37. Washington, D.C.
- Patten, B. C., ed. 1971. Systems analysis and simulation in ecology. Academic Press, New York. 607 pp.

# THE CONSTRUCTION OF A CONCEPTUAL MODEL OF THE CHENIER PLAIN COASTAL ECOSYSTEM IN LOUISIANA AND TEXAS

L. M. Bahr, Jr.,<sup>1</sup> J. W. Day, Jr.,<sup>1</sup> T. Gayle,<sup>2</sup>  
J. G. Gosselink,<sup>1</sup> C. S. Hopkins,<sup>1</sup> and D. Stellar<sup>1</sup>

## INTRODUCTION

Increasing interest in coastal areas on the part of environmentalists, developers, and managers has generated the need to understand the function of these productive and fragile areas, and to predict the effects of further alterations to them. The term "function" as used throughout the following description of the Chenier Plain conceptual model is intended to describe the mechanics of the ecosystem, i.e., the pathways and processes by which energy and matter are captured, transferred, partitioned, stored, cycled, and degraded by the system. Examples of functional processes include primary production, water flow, trophic exchanges, and animal migrations. Functional understanding of an ecosystem includes much more than an inventory of important physical parameters and organisms; it requires a holistic, systems-level analysis which identifies important interactions among biological and physical components of the system, and all important control features and feedback mechanisms.

In late 1975, the Fish and Wildlife Service (FWS), U.S. Department of the Interior, funded a study of the Chenier Plain coastal ecosystem(s) of southeastern Texas and southwestern Louisiana (Galveston Bay, Tex., to Vermilion Bay, La.) in which the area would be characterized ecologically by the development of a conceptual model of the system and a synthesis of all extant data. This characterization was designed to serve as a pilot study for similar projects which will eventually describe all U.S. coastal ecosystems. The specific request was for a "description of the important resources and processes comprising the ecosystem and an understanding of their functional relationships." (FWS Request for Proposal, 4 December 1975.) The first requirement of this study (and the key to the

entire project) was the formulation of a conceptual model of the ecosystem(s). The model was to consist of a schematic framework of ecosystem function in which all important processes and interactions among components would be identified in a qualitative manner. The completed model would identify data requirements and gaps, and set the stage for the two remaining portions of the study, a characterization atlas, and a quantitative ecological simulation model of the study area which could be used to aid in making management decisions.

The study area is called the Chenier Plain, so named because of a series of prominent ridges known as cheniers that transect the region from east to west. "Chenier" is a French word meaning "place of oaks;" the vegetation of undisturbed chenier ridges is characteristically dominated by live oak (*Quercus virginiana*) trees. |

This report describes the structure of the conceptual model developed for this study and discusses the technical and management problems it was designed to solve.

## PROBLEM

Any ecological model of the Louisiana-Texas Chenier Plain must take into account the following four factors:

1. Spatial heterogeneity. The area described as the Chenier Plain (fig. 1) is highly variable in space; from east to west it is broken up by a series of rivers flowing southward into the Gulf, through lakes of different sizes and salinities, and over thousands of square miles of wetland. The wetlands themselves are not all homogeneous; vegetation ranges from pure stands of saline oyster grass (*Spartina alterniflora*) to fresh water bull-tongue (*Sagittaria falcata*) and maidencane (*Panicum hemitomon*). They are cut by elevated cheniers or ridges which function

<sup>1</sup>Center for Wetland Resources, Louisiana State University, Baton Rouge, La. 70803

<sup>2</sup>Center for Wetlands, University of Florida, Gainesville, Fla. 32601.



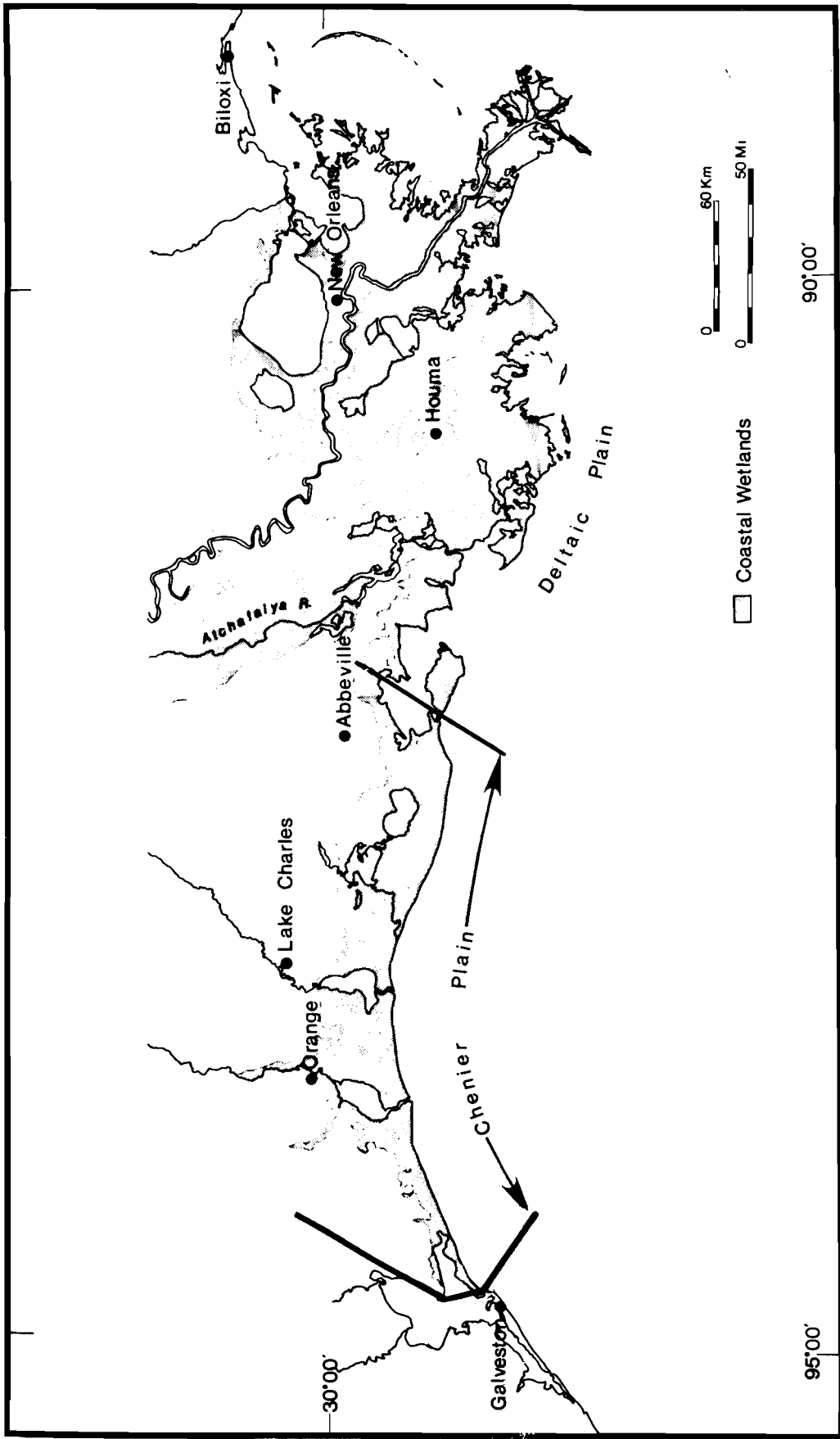

Figure 1. The Chemier Plain region of southwestern Louisiana and southeastern Texas.

ecologically much differently from the adjacent wetlands. Large areas, wetland and highland, have been modified for agriculture or are managed for waterfowl or furbearers. The region is far from homogeneous and any model that ignores this will produce information of limited management value.

2. Ecological or functional complexity. Aside from this spatial heterogeneity, within any small, fairly homogeneous area, the ecological food web is enormously complex and, on the whole, poorly understood.
3. Time scale of events. Events of ecological interest in the Chenier Plain, which determine the physiography of the whole region, occur on the scale of hours, days or seasons for many biological processes; years or tens of years for many cumulative impacts, such as canal dredging and eutrophication; and thousands of years for geological processes. It is difficult to visualize a useful model which can simultaneously simulate geological processes and microbial kinetics in terms useful to a manager.
4. Management needs. In addition to the above considerations the model must enable a manager to evaluate the consequences of alternate management strategies at appropriate levels of spatial, ecological and temporal resolution. Existing models cover a wide range of approaches, including strategies to exploit or manage single commercial species [such as fishery models (Wagner 1969) or alligator models (Nichols et al. 1976)]; models which treat ecosystems as homogeneous in space in order to elaborate the energetic interactions (Patten et al. 1975; Wiegert et al. 1975); models which treat spatial heterogeneity but consider only a limited number of chemical or biological parameters (Kremer and Nixon 1975), and dramatically simplified, dynamic world-view models (Forrester 1971).

## SOLUTION

The problems of resolution, complexity, and time frame were addressed by the construction of nested hierarchical conceptual models at four levels of resolution: region, drainage basin, habitat, and population levels (fig. 2). Individual populations

are components of habitats, the smallest ecological units described in the Chenier Plain. Each habitat is considered homogeneous in space. Each of the six Chenier Plain basins is a spatially heterogeneous area composed of a number of interacting habitats. The time scale of events of interest increases from habitat to region.

## THE CHENIER PLAIN REGION

The Chenier Plain region is unified by a common geologic history; the sediments that underlie this major coastal system originated primarily from riverine sediments supplied by the Mississippi River. The primary geophysical process responsible for the unique physiography of the Chenier Plain has been the periodic alteration in course of the main tributary of the Mississippi River. This switch has occurred on the average about every 400 years over the last 7,000 years, and has caused major changes in sediment input to the Chenier Plain region. For example, when the river is discharging on the eastern side of its delta (as it is presently, see fig. 1), little sediment reaches the Chenier Plain. But when the discharge is on the western side much sediment reaches the Chenier region. In the former case, erosion dominates, and in the latter, deposition and growth dominate. The Atchafalaya River, just east of the Chenier Plain (fig. 1), is beginning the long process of capturing the main channel flow of the Mississippi River, and accretion is beginning to reverse the shoreline retreat measured over the past several decades.

Change in sediment availability has in turn been reflected in the formation of the cheniers, which are stranded dune ridges parallel to the present shoreline. Man has had little effect on the regional development of the Chenier Plain.

The conceptual model of the Chenier Plain region is primarily a model of geological processes (fig. 3). The symbolic "energese" language (Odum 1972) is used in the models illustrated. It is discussed more fully in Bahr et al. (1977). Figure legends are complete enough for readers to follow the diagrams without full comprehension of the symbols. These processes are not strongly influenced by man, except as he controls the flow of the Mississippi River.

## BASINS

Drainage basins represent perhaps the most natural category of ecological systems in the Chenier Plain region, because each basin is integrated by the flow of water over and through it; yet

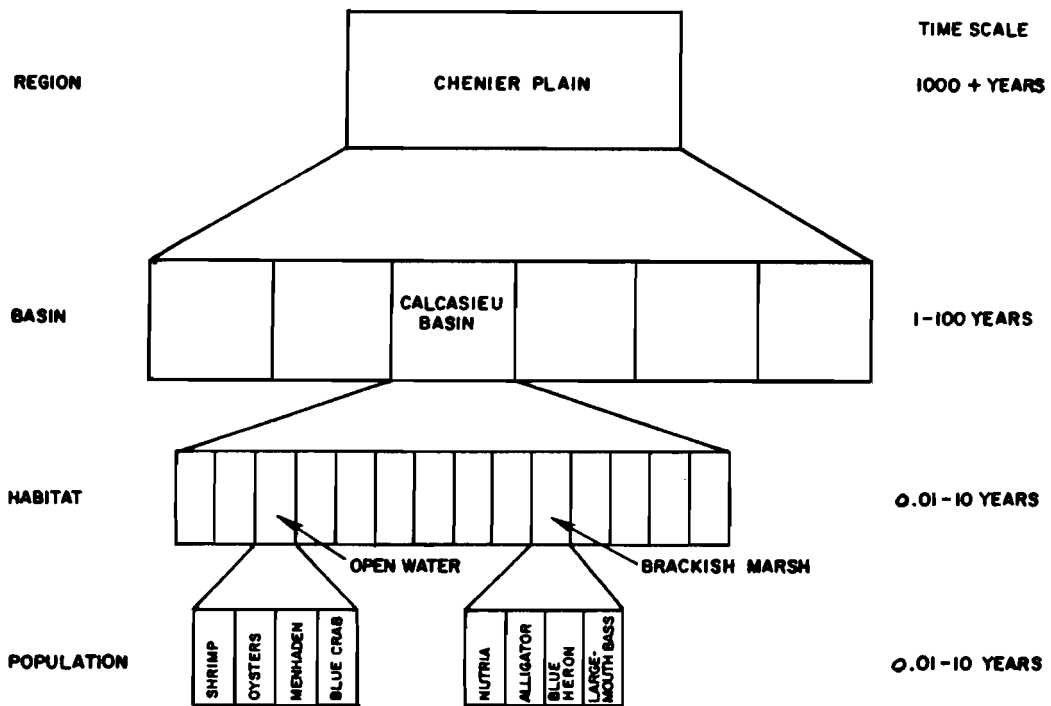

Figure 2. The Chenier Plain conceptual hierarchy.

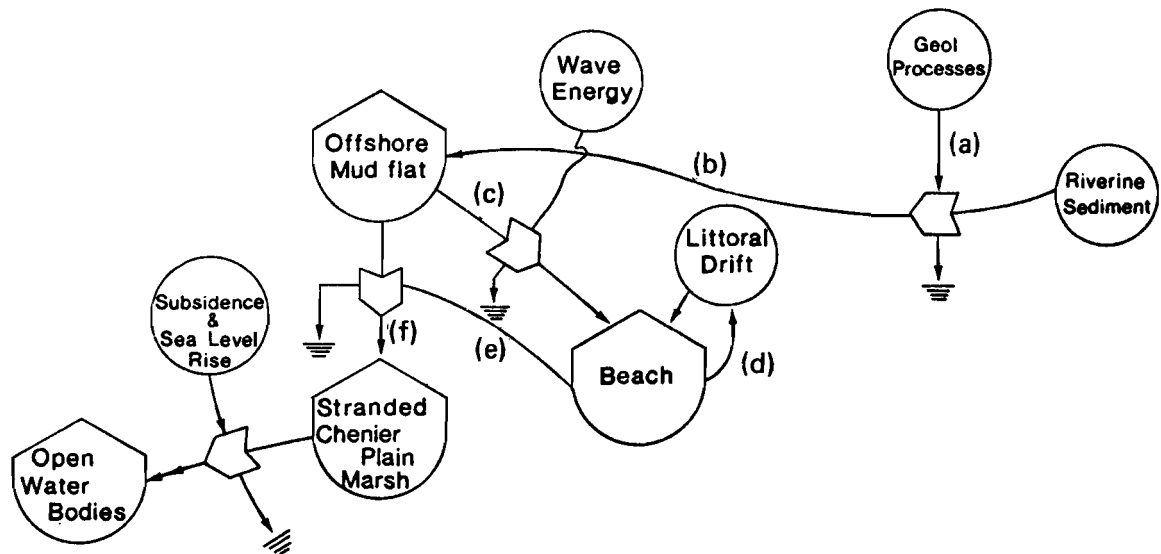

Figure 3. A simplified model of the formation of the Chenier Plain system. Geologic processes (a) lead to the Mississippi River switching course and control the supply of riverine sediments (b). These sediments form an offshore mud flat. If sediment supply dwindles, the wave energy causes the offshore mud flat to form a beach (c). The beach gains and loses sediment through littoral drift (d). As the beach grows up, it strands the mud flat and forms a stranded Chenier Plain marsh (e, f). Subsidence or sea-level rise can transform this marsh into open water.

each basin is relatively autonomous from adjacent basins in terms of water circulation. Six fairly distinct basins have been identified in the Chenier Plain (fig. 4). Each basin has its own hydrodynamic characteristics determined by such parameters as size, drainage density, downstream flow, elevation and slope of the basin, and extent of its connection with the Gulf via tidal passes.

Most significant changes in a basin occur through large-scale and cumulative effects over a period of time measured in years, rather than in hundreds of years. Examples include: effects of deep shipping channels on saltwater intrusion; changes in hydrology associated with stream channelization; canal dredging and associated spoil bank formation; and cumulative wetland drainage for urban and industrial development.

### HABITATS

The habitat is the smallest ecological system considered in our conceptual model. Wherever a particular habitat occurs on the Chenier Plain it is treated as the same basic functional unit, and can therefore be treated as homogeneous, even though we recognize the existence of gradients, specialized niches, and discontinuities. Each habitat is a complex ecological system characterized by its own species, carrying capacities for those species, levels of production, food web, nutrient cycles, and physical inputs. The time scale of important events is often seasonal, and short term impacts are important at this level.

Most habitats are intuitively distinct. For example, aquatic systems are quite different from upland forests; however, different kinds of natural wetlands are not so clearly unique. For the Chenier Plain we have identified and mapped 10 natural habitats: nearshore Gulf; inland open water; salt, brackish, intermediate, and fresh marsh; wetland forest; upland forest; beaches; and cheniers and ridges. Large areas have been modified by human activity, which we have catalogued into four additional habitats as impounded marshes, pastures, rice and crop habitat, and urban habitat.

Complex habitat level models have been constructed for each of the 14 habitats to give a qualitative functional understanding of each habitat, and to guide the acquisition of data. As illustrations of the habitat models, figure 5 shows the aquatic inland open habitat model as it appears in the conceptual model (Bahr et al. 1977). Figure 6 represents simplified version of the aquatic habitats (inshore open water and nearshore Gulf of México).

In the conceptual model document, figure 5 is accompanied by a detailed interaction matrix keyed to each of the compartments. Figure 7 is the generalized wetland habitat model, and figure 8 is the agricultural model, both from the characterization atlas. We are at present relatively ignorant of the internal working of most habitats; thus, those that are managed/exploited are manipulated at some peril to the function of the whole system. A better approach to management is to recognize that certain renewable resources (or nonresources; Ehrenfeld 1976) are associated with any habitat, and in order to protect the resource, one must protect the habitat.

### POPULATIONS

Habitats can be considered as ecological landscape units composed of many different populations interacting with each other and with their physical surroundings. At the bottom of the conceptual hierarchy of natural history, growth dynamics and environmental limits are considered for species of economic, recreational, or functional importance in the Chenier Plain region. The carrying capacity of a habitat for a particular species is an important concept that relates the species to its habitat. Major opportunities for management of a single species or group of related species occur through manipulation of habitat (for instance, by impounding wetlands), or through direct control of population size through harvesting (fig. 9).

### THE BASIN-LEVEL CONCEPTUAL MODEL

The major kinds of manageable processes and the time scales of manageable events appear to occur at the basin level. For this reason, major emphasis in this discussion is placed on the basin-level analysis.

Figure 10 summarizes basin-level processes and interactions. This model is the result of a series of iterative changes and simplifications of earlier, more detailed, models of basin function (Bahr et al. 1977). It is extremely aggregated and simplified in order to include only the most critical components and processes, and to show how water, wetlands, and man interact in a hypothetical drainage basin.

The basin model is divided into four linked submodels (fig. 10) each representing a different set of processes, and each in part responsible for the present state of a basin, and for the rate at which it is changing. The four submodels are:

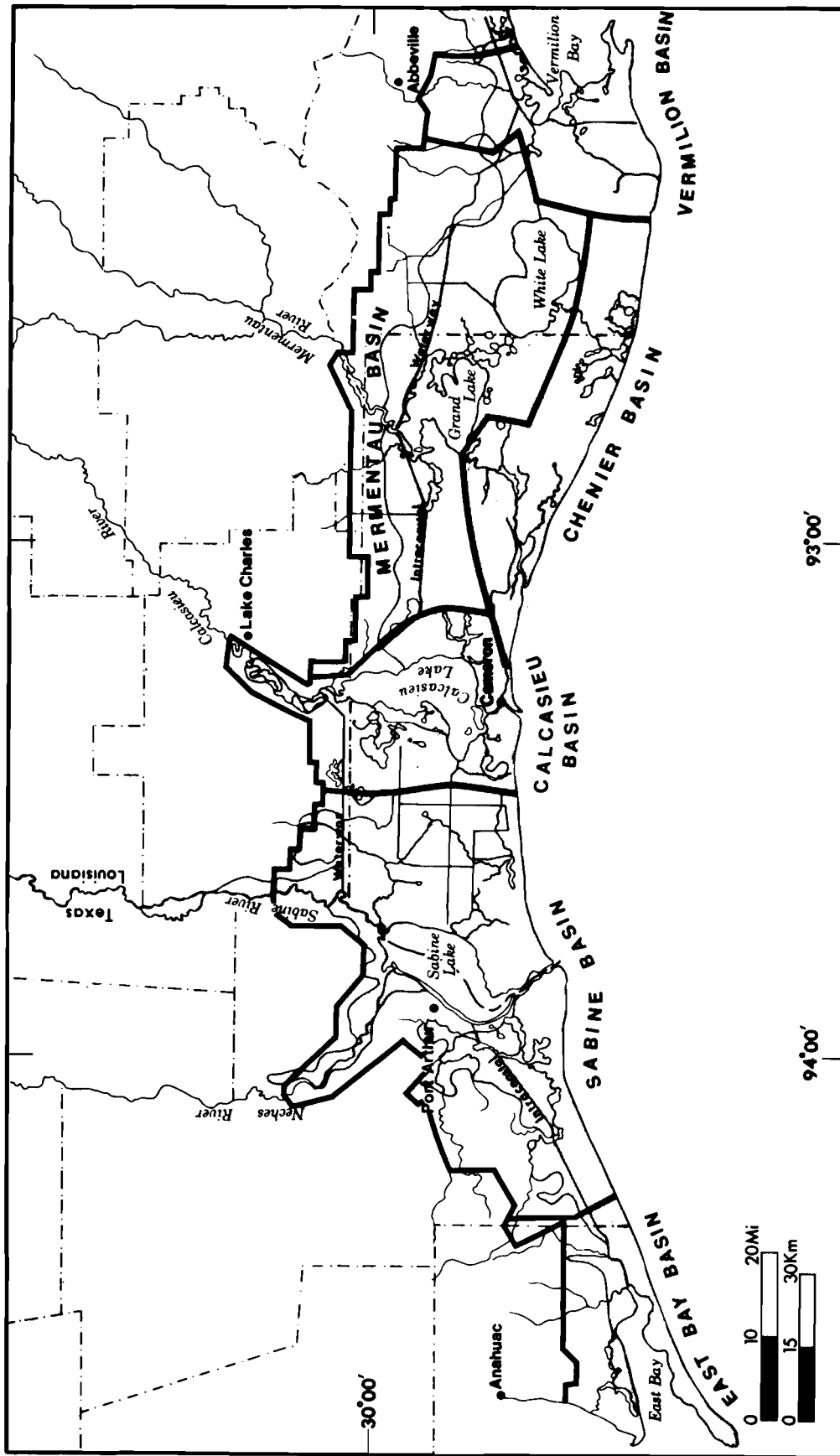

Figure 4. The Chenier Plain region is composed of six basins, within which water is the primary integrating element.

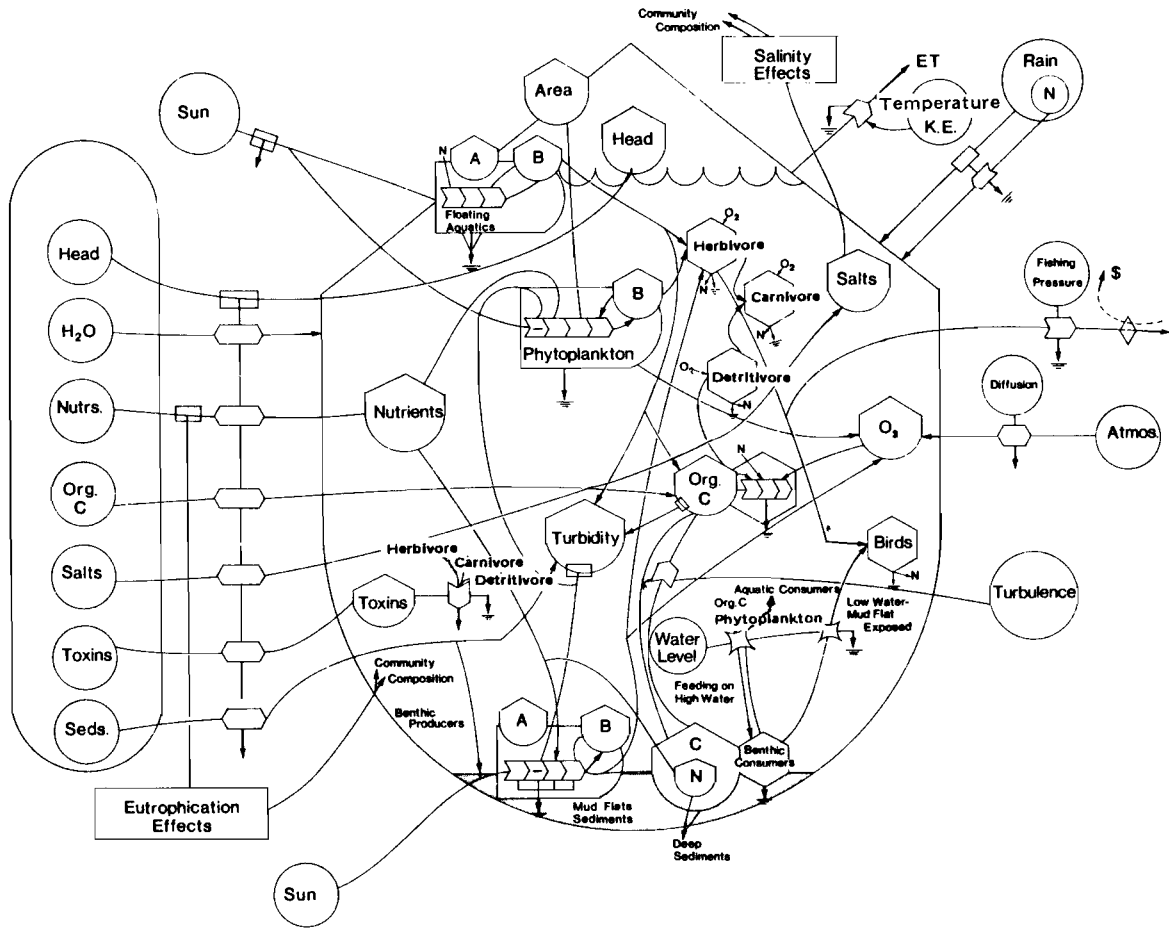

Figure 5. Aquatic inland open water habitat model.

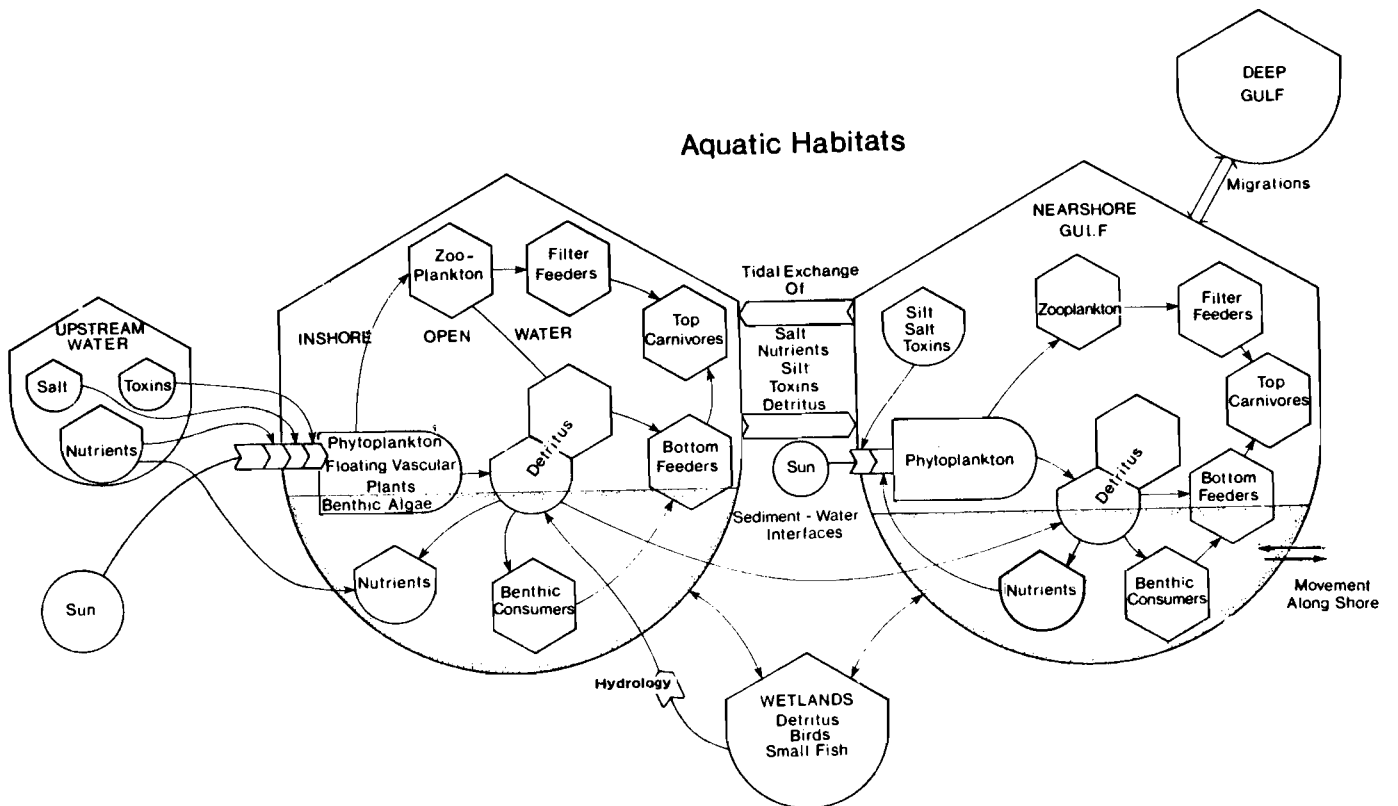

Figure 6. This simplified version of figure 5 combines both aquatic habitats, showing the major biological compartments and interactions. Heat sinks representing energy loss are implied at each interaction.

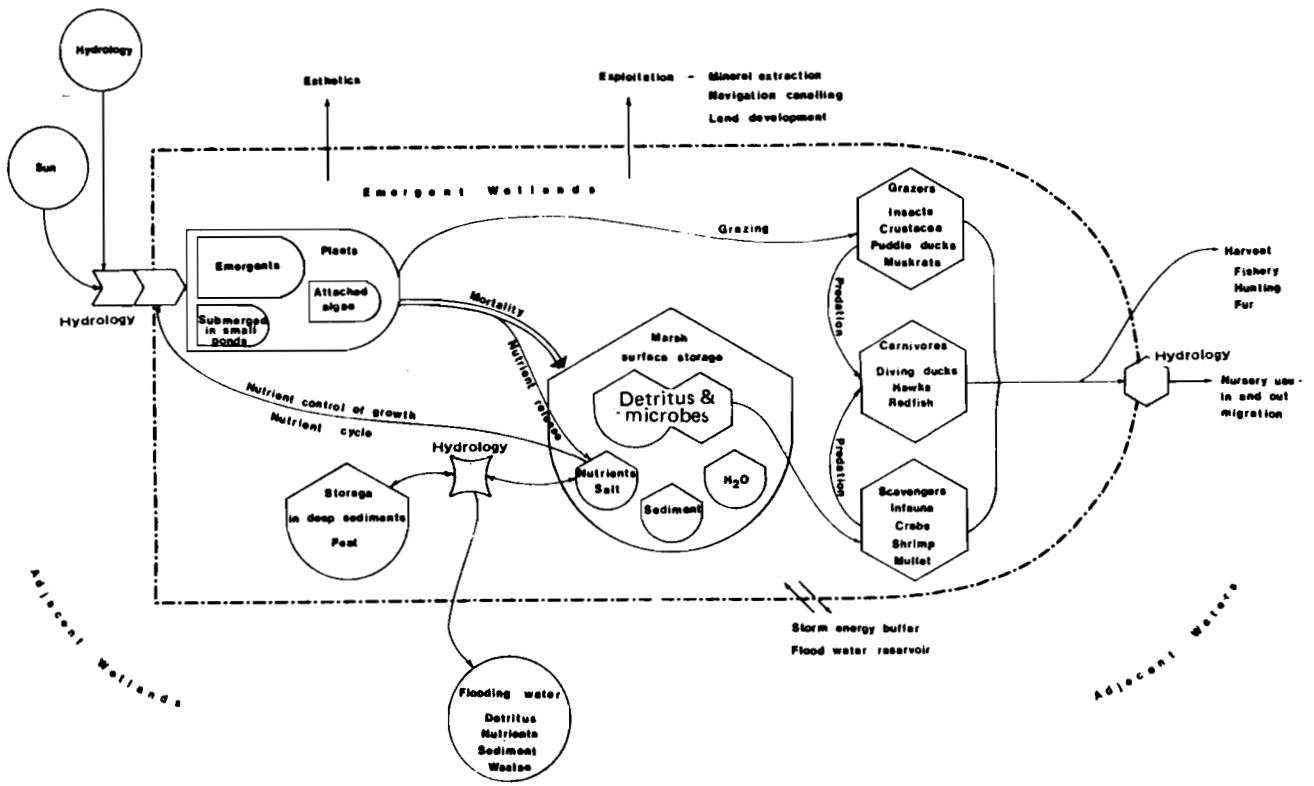

Figure 7. The general wetland habitat model displays the major functional groups and major processes occurring in wetland systems. Heat sinks representing energy loss are implied at each interaction.

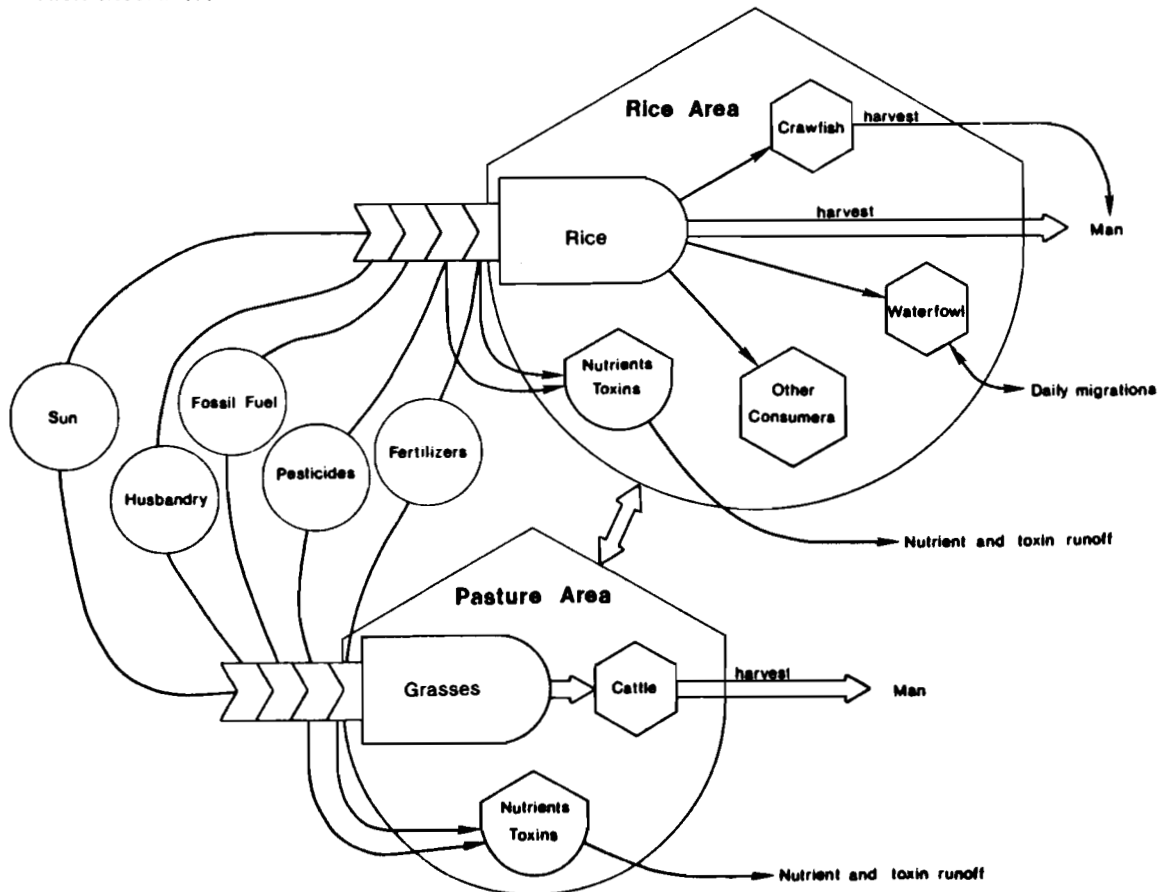

Figure 8. The agricultural sector is much simplified ecologically, because cultural practices subsidized by heavy fossil fuel and fertilizer inputs simplify the food chain. Heat sinks representing energy loss are implied at each interaction.

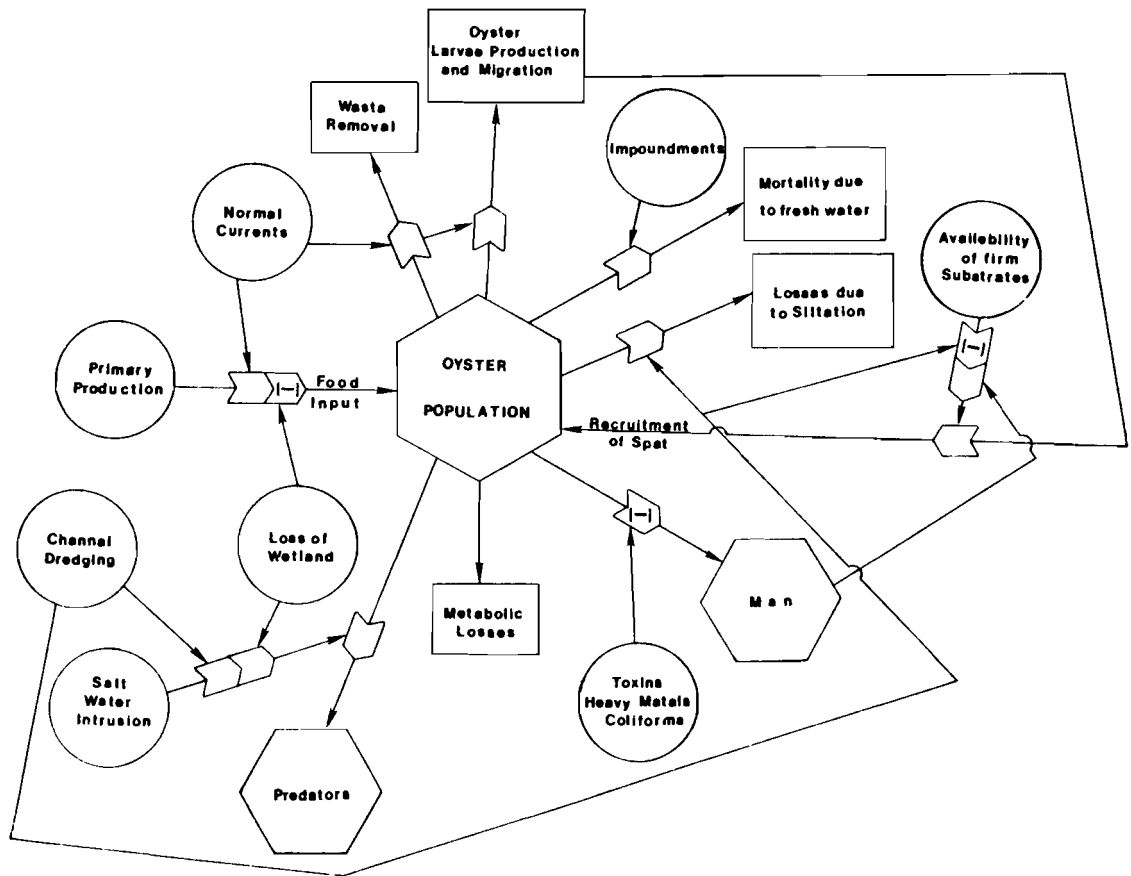

Figure 9. This representation of the major factors controlling the survival and growth of oysters is an example of population-level models.

### Hypothetical Basin Model

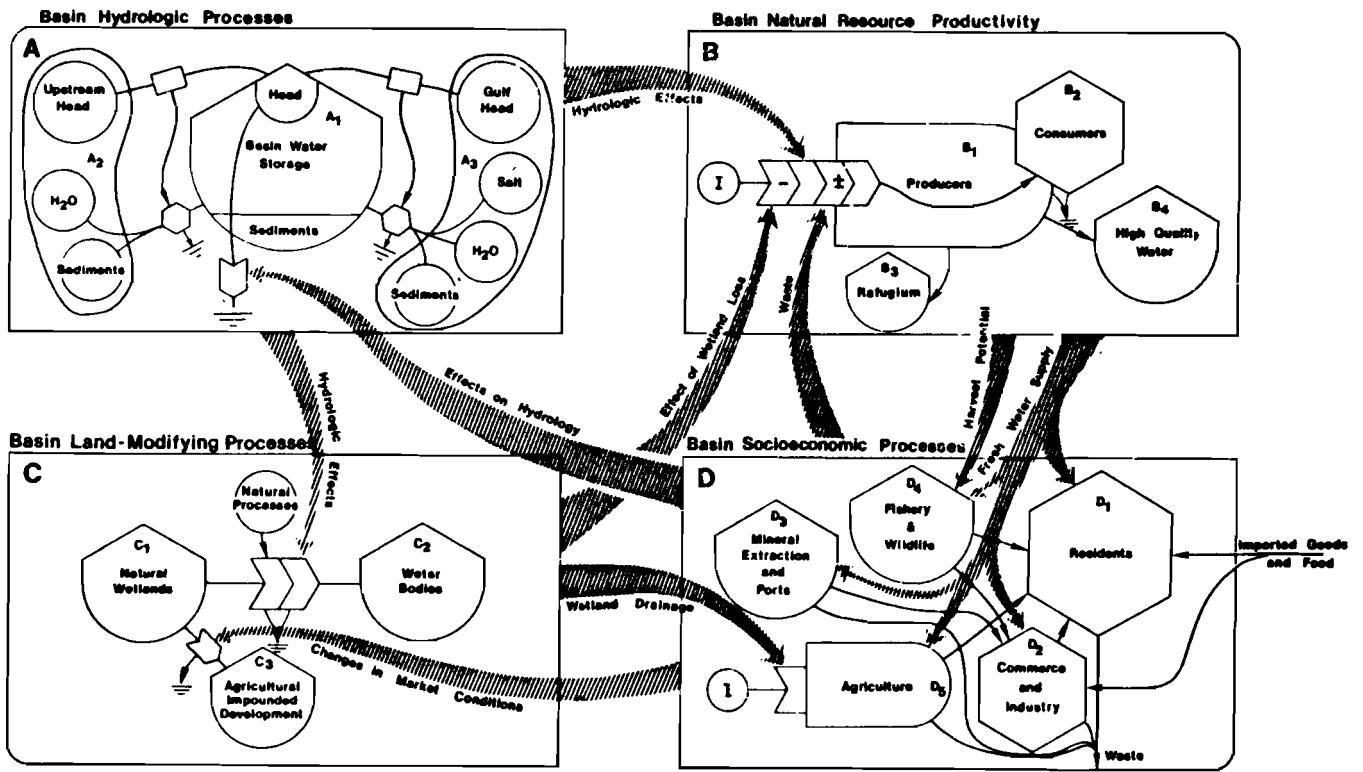

Figure 10. For simplicity, the basin is considered as four interacting sets of processes.



- (A) Basin hydrologic processes, or water storage and flow through a basin;
- (B) The natural resource productivity of a basin, or its capacity to support wildlife and fishery species, and to perform other work services for man, such as the purification and storage of fresh water;
- (C) Land modifying processes, particularly those which result in loss of natural wetland; and
- (D) Basin-level socioeconomic processes, or those human activities and management decisions that impinge directly on natural processes in a basin.

#### HYDROLOGY (A)

The hydrologic regime at any specific site within a Chenier Plain basin is ultimately responsible for determining the kind of habitat that develops at that site. Basin hydrology results from interactions among three modules (fig. 10); water storage in a basin ( $A_1$ ); upstream riverine and rainfall inputs of water and sediment ( $A_2$ ); and downstream water with accompanying salts and sediments and tidal and oceanic storm forces ( $A_3$ ).

The role of hydrology in determining habitat type is primarily mediated via water levels and durations, and salinity levels and durations. Water levels are controlled by the pressure head between water level at a given site, and upstream and downstream water levels. If rainfall raises water levels upstream, water flows toward the Gulf; likewise, if tidal stage or a southerly wind raises sea level at the Gulf, a wave proceeds upstream, gradually diminishing as it goes.

Mean salinity and salinity range at a given site in the basin are determined by mixing, over time, of upstream and downstream inputs, and by the relative volumes of fresh and saline water inputs. Sediments are carried into a basin by the currents produced by salinity (density) and pressure gradients. Sediment deposition is a function of current speed, sediment load, salinity, and in some cases, biological activity.

In summary, the hydrologic submodel symbolizes the complex physiographic configuration of a basin, which, together with upstream and downstream water inputs, determines water level, water flow, salinity, and sediment regimes at any point in a basin. These parameters, in turn, constrain the

type of habitat that can develop at any site in question. For example, if water level is always below the land surface, then the habitat is terrestrial. If the water level is always above the land surface, then the habitat is aquatic. If water level alternates above and below the land surface, the habitat is wetland. Salinity dynamics determine whether a habitat will be fresh or saline, and sediment dynamics (either gain or loss) can change one habitat to another. Man's activity is an important factor affecting water, salinity, and sediment cycles.

#### NATURAL RESOURCE PRODUCTIVITY (B)

Submodel B (fig. 10) represents the natural work services of a basin; that is, the quality of a basin with respect to its ability to do such things as support important fishery and wildlife species, and to "purify" and store water, all at no cost to man. "Quality" refers to both the particular blend of habitats that comprise one basin, and to the fact that two areas having similar habitat types can vary greatly in their ability to support consumer organisms. For example, the open water habitat can be in a balanced state with respect to nutrient input and use, or it can be degraded (by excess nutrient loading) into various degrees of eutrophication.

The natural resource productivity (NRP) submodel consists of four components (fig. 10): producers ( $B_1$ ), consumers ( $B_2$ ), a refugium ( $B_3$ ), and a water storage module ( $B_4$ ).  $B_1$  and  $B_2$  represent the species that occur naturally in all wetlands, water bodies, and ridges in a basin. A particular habitat can be characterized by its carrying capacity for these species; as its quality diminishes, so does its carrying capacity. Diminishing quality may also lead to changes in community structure such as the proliferation of undesirable fish species in eutrophic waters.

Wetlands are natural water reservoirs. Fresh wetlands and water bodies are especially valuable for storing surface water, which is often used by man. For example, much of the irrigation water for rice in Louisiana and Texas is stored in fresh marshes. Ground water often extends beyond basin boundaries, becoming a regional resource.

As water flows over wetlands, many chemical transformations take place. Inorganic nutrients, which could encourage eutrophic conditions in aquatic habitats, undergo important changes. The

nutrients may be taken up during plant growth or by bacteria during detritus formation. Some of these nutrients may be exported later as organic detritus, a form more compatible with natural populations. Phosphorus may physically bind with sediments, and nitrogen may be denitrified.

The natural resource productivity of a basin is thus a function of the particular mix of habitat types, especially the relative proportions of natural wetlands and water bodies, and the degree of human perturbation.

#### LAND MODIFYING PROCESSES (C)

Submodel C (fig. 10) represents the dynamic habitat area changes that occur within a basin of constant area. Over the past several thousand years, the dominant trend has been the growth of the wetland habitat concurrent with the formation of new chenier ridges. The aerial gain of these habitats was at the expense of aquatic habitats (nearshore Gulf and inland water bodies). During the past 50 years, however, the major change has been loss of natural wetland (C<sub>1</sub>), either to open water (C<sub>2</sub>), or by impoundment for waterfowl and/or agriculture (C<sub>3</sub>). Basically two processes cause loss of natural wetland: hydrologic changes resulting from canalling, marsh burning, or impounding; and natural subsidence and erosion. Hydrologic changes are not always local phenomena. For example, artificial maintenance of the present Mississippi River course on the eastern side of the delta means that very little new sediment is reaching the area.

#### SOCIOECONOMIC FACTORS (D)

Submodel D represents human effects at the basin level (fig. 10). Socioeconomic factors have been lumped into five main components:

1. The total human population in a basin (D<sub>1</sub>), its energy and material requirements and its waste production;
2. Commerce and industry (D<sub>2</sub>) such as manufacturing, refining, retail sales, etc., that occur in a basin, along with the concomitant waste release;
3. Mineral resources in a basin (D<sub>3</sub>), primarily petroleum and natural gas (port and navigation facilities are included here); the extraction of minerals and maintenance of navigation channels entails release of waste, as well as extensive disruption of natural habitats (dredging, etc.);

4. Fishery and wildlife resources harvested by man (D<sub>4</sub>) both commercially and for sports purposes; and
5. All agricultural activity (D<sub>5</sub>), especially rice and cattle. This activity also entails significant waste release, especially nutrients and pesticides.

D<sub>1</sub>, D<sub>2</sub>, and D<sub>5</sub> all require large quantities of fresh water. Some species in D<sub>4</sub>, especially waterfowl, are limited by freshwater bodies, and D<sub>3</sub> requires fresh water for some processes.

#### BASIN SYNTHESIS

The water requirement of the socioeconomic submodel (fig. 10) is a convenient place to begin a discussion of the connections among the four basin submodels. The basin natural resource fresh water (B) is required by all five components of submodel D, as indicated by the broad-branched arrow. Many of these water needs are met by groundwater pumping, but surface fresh water is also used, especially for rice irrigation and waterfowl habitat. The other input to submodel D from submodel B represents the harvest of commercial and sports fisheries and wildlife, which is a function of basin quality or natural resource productivity.

Effects of the socioeconomic sector on other submodels are broken down into waste effects, effects on hydrology, and developmental decisions based on market conditions (economics) that lead to habitat changes.

Wastes, which include nutrients, toxins, and dredged spoil, affect the natural resource productivity of a basin. Nutrient wastes, such as sewage or fertilizer, can decrease NRP by causing eutrophication, or if applied judiciously to wetlands, can actually increase NRP. Toxins such as pesticides and heavy metals generally lower NRP, and may selectively reduce higher consumers without affecting lower trophic levels. Another form of waste is dredged material which can create silting problems, e.g., destruction of oyster beds by siltation.

The socioeconomic sector affects basin hydrology via activities that disturb natural circulation patterns, especially by dredging canals or navigation channels (Stone and McHugh 1977). Freshwater pumping can also affect hydrologic change by lowering the water head relative to sea level and causing salt water intrusion. Freshwater availability is so critical to all socioeconomic sectors that it can set ultimate limits to economic growth and development in a given basin.

Socioeconomic effects on physiography (C) include decisions that lead to development of natural wetland areas for economic gain, or for human leisure use. Examples include decisions to "reclaim" wetland for agriculture or for duck habitat.

Another major cause of wetland loss arises from long-range hydrologic changes that accompany canaling and other local wetland perturbation (arrow from A to C in fig. 10). This same change in local hydrology affects the natural resource productivity (arrow from C to B).

### SUMMARY

The generalized Chenier Plain basin ecosystem and its critical wetland component is basically driven by hydrologic forces. Habitat area changes are primarily wetland loss to open water and to impoundments, resulting in modification of natural resource productivity. All three of these processes (hydrologic, habitat, and resource productivity changes) are strongly influenced by the intensity of human socioeconomic activity in the basin.

### LITERATURE CITED

- Bahr, L. M., J. W. Day, Jr., T. Gayle, and C. S. Hopkinson. 1977. A conceptual model of the Chenier Plain coastal ecosystem of Texas and Louisiana. Louisiana State Univ. Cent. for Wetland Resour., Baton Rouge.
- Ehrenfield, D. W. 1976. The conservation of non-resources. *Am. Sci.* 64(6):648-656.
- Forrester, J. W. 1971. *World dynamics*. Wright Allen, Cambridge, Massachusetts. 142 pp.
- Kremer, J. N., and S. W. Nixon. 1975. An ecological simulation model of Narragansett Bay—The plankton community. Pages 672-690 in L. E. Cronin, ed. *Estuarine Research*, Vol. 1. Academic Press, New York.
- Nichols, J. D., L. Viehmaw, R. H. Chabreck, and B. Fenderson. 1976. Simulation of a commercially harvested alligator population in Louisiana. La. State Univ. Agri. Exp. Stn. Bull. 691. 59 pp.
- Odum, H. T. 1972. An energy circuit language for ecological and social systems: its physical basis. in B. C. Patten ed., *Systems Analysis and Simulation in Ecology*, Vol. 2. Academic Press., N.Y.
- Patten, B. C., D. A. Egloff, and T. H. Richardson. 1975. Total ecosystem model for a cove in Lake Texoma. in B. C. Patten ed., *Systems Analysis and Simulation in Ecology*, Vol. 4. Academic Press, N.Y.
- Stone, J. H., and G. F. McHugh. 1977. Simulated hydrologic effects of canals in Barataria Basin: A preliminary study of cumulative impacts. Rept. to Louisiana State Planning Office.
- Wagner, F. H. 1969. Ecosystem concepts in fish and game management. Pages 259-307 in G. Van Dyne ed., *The Ecosystem Concept in Natural Resource Management*. Academic Press, N.Y.
- Wiegert, R. G., R. R. Christian, J. L. Gallagher, J. R. Hall, R. D. H. Jones, and R. L. Wetzel. 1975. A preliminary ecosystem model of a coastal Georgia *Spartina* marsh. Pages 583-601 in L. E. Cronin ed., *Estuarine Research*, Vol. 1. Academic Press, N.Y.

## MAINE COAST CHARACTERIZATION USER'S GUIDE

Stewart I. Fefer,<sup>1</sup> Curtis Laffin,<sup>2</sup> Larry Thornton,<sup>1</sup>  
Patty Schettig,<sup>1</sup> and Russ Brami<sup>1</sup>

### INTRODUCTION

The evaluation of natural resources, and thorough reviews of their alternative uses, are essential components of any decisionmaking process affecting our environment. There must be a basis for establishing policies affecting land use and conservation of resources; a holistic approach integrating the many disciplines of natural resources is the foundation upon which these policies can be built. The objective should be to maintain a diverse and productive natural environment. The holistic approach set forth here is known as the Ecological Characterization of Coastal Maine.

An environmental management program must embrace whole ecosystems (Van Dyne 1969, Odum 1971, Moen 1973, Clark 1977, Likens et al. 1977). "Ecosystem" is defined by Odum (1971) as "... any area of nature that includes living organisms and non-living substances interacting to produce an exchange of materials between the living and the non-living parts." It is a general term concerned with structural and functional relationships, but without precise information about these relationships, it is difficult to assess the impact of human activities on an ecosystem. Lack of ecosystem understanding has caused management practices to emphasize strategies that maximize the output of some desirable product, i.e., species management of waterfowl or fishes. It is evident that a new conceptual approach to the management of resources is desirable (Likens et al. 1977). The characterization is designed to provide an ecosystem view of the Maine coastal zone, from Cape Elizabeth to Eastport (fig. 1) by treating entire ecological systems as single interacting units and describing:

1. Driving forces of the Maine coastal ecosystem;

2. The components of the ecosystem;
3. Functions of components;
4. Interrelationships of components and functions; and
5. Seasonal and long-term changes of components.

Specific objectives of the ecological characterization are to:

1. Obtain and synthesize available ecological data which describe important resources, processes, and their interrelationships within the study area;
2. Identify information deficiencies and research priorities; and
3. Provide an assessment of the state of knowledge for the Maine coast ecosystem.

The characterization serves the needs of (1) the administrator and planner when making decisions on land-use planning and natural resource management and (2) the scientist seeking the status of Maine coast ecological knowledge in disciplines relative to his or her field.

The Maine Coast Ecological Characterization will be completed in late 1979. This User's Guide, in its revised form, will be a part of the completed characterization; it directs various users how to manipulate the materials in the characterization to satisfy their specific needs.

### THE PHYSIOGRAPHIC ECOSYSTEM— THE MAINE COAST

Land forms reflect the geologic events which have had a major influence on the evolution of the biota because the types and structures of bedrock exposed to uplifting, weathering, and glaciation have had a great influence on the physiography of the Maine coast. The development of vegetation is controlled by these factors, climate, and animals (including man). The native fauna has evolved because of its compatibility with the established vegetative community (Shelford 1963). The land-use activities of man have also been influenced by physiographic constraints. Thus, physiography is a major influence on the physical, biological, and

<sup>1</sup>Energy Resources Company, Inc., Cambridge, Mass.

<sup>2</sup>Fish and Wildlife Service, U.S. Dept. of the Interior, Newton Corner, Mass.

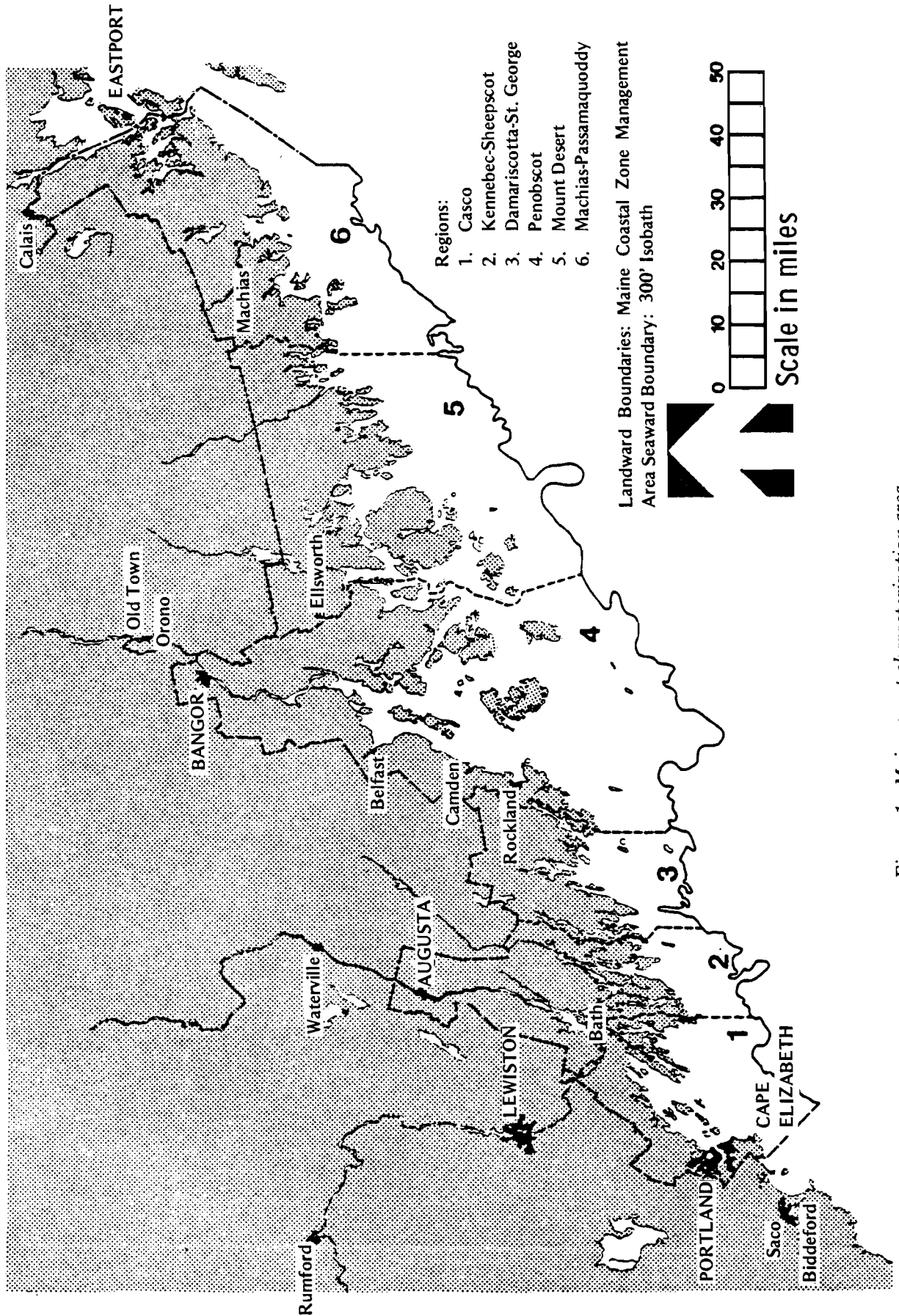

Figure 1. Maine coast characterization area.

man-induced interactions that take place, rendering physiographic boundaries as logical limits for delineating regional ecosystems.

The coast of Maine north and east of Cape Elizabeth is considered a discrete physiographic ecosystem. The character of this area is quite different from that of southern Maine, New Hampshire, and Massachusetts; it is identified by its long, deep, steep shores and rock headlands. Large shallow embayments are common and approximately 3,000 coastal islands ranging from less than 1 ha to 26,000 ha occur within 16 km (10 miles) of the mainland. More areas of rock and silt and fewer sand and salt marshes occur along the coastline of the characterization area than in coastal areas to the south.

## CLASSIFICATION MODEL

### THE ECOSYSTEM APPROACH

In order to meaningfully describe the components, functions, and interactions of the Maine coast ecosystem, it will be necessary to impose classification boundaries on those habitats having relatively distinct functions.

The U.S. Fish and Wildlife Service, Office of Biological Services, has designed a National Classification of Wetland and Deepwater Habitats of the United States (Cowardin et al. 1977). The structure of this classification system is hierarchical and moves from systems and subsystems at the general level down to classes and dominance types.

The Maine State Planning Office (1974) has developed a classification system for terrestrial land cover. Among the features of these classifications is the ability to group ecologically similar units. These classifications are, therefore, useful for characterization and have been adapted to the Maine coast study to structure and explain components, functions, and interactions inherent in the coastal Maine ecosystem.

### THE HABITATS

Within the Maine coast ecosystem, three generalized habitat types are recognized: deepwater, wetland, and terrestrial. "Deepwater habitats include environments where surface water is permanent and often quite deep so that water, rather than air, is the principal medium within which the dominant organisms live, whether they are attached to the substrate or not. Wetland is land where water is the dominant factor determin-

ing the nature of soil development and the types of plant and animal communities living in the soil and on its surface" (Cowardin et al., 1977). Terrestrial habitats exist where water is not the dominant influencing factor but where nonhydric soils exist. These habitats are divided into systems, subsystems, and classes.

### SYSTEMS

"The term 'system' here refers to a complex of wetland, deepwater and terrestrial habitats that share the influence of hydrologic, geomorphologic, chemical or biologic factors" (Cowardin et al. 1977). Each habitat thus comprises systems and subsystems, so that a hierarchical conceptual model is appropriate.

We have thus far separated the Maine coast ecosystem into habitats, systems, subsystems, and classes, each with certain distinct components and functions which will be explained later. These habitats, systems, subsystems, and classes interact as part of a whole functioning ecosystem. Thus, the ecosystem is emerging in the form of a gigantic quasiorganism. The hierarchical structure and general view of the composite systems in Maine are presented in figure 2. Each habitat and composite system is further illustrated in figures 3, 4, and 5. A conceptual model has been developed that portrays this classification system's components, functions, and interactions.

### THE CONCEPTUAL MODEL AND ITS APPLICATIONS TO THE MAINE COAST ECOSYSTEM

The general portrayal of the conceptual model begins with the ecosystem and its driving forces, which include climate, tides, geology, and socioeconomic factors interacting to form the template with which the biotic realm must contend. In order to illustrate the interactions within the ecosystem (systems and classes) the discussion in the first volume of this characterization focuses on four primary concepts:

1. Energy—In ecology, we are concerned with the manner in which sunlight is related to ecological systems, and with the manner in which energy is transformed within the system (Odum 1971). Thus, the relationships between producer plants and consumer animals, and between predators and prey are all limited and controlled by the



### MAINE COAST ECOSYSTEM

- | Deepwater     | Wetland       | Terrestrial        |
|---------------|---------------|--------------------|
| 1. Marine     | 5. Marine     | 10. Forest         |
| 2. Estuarine  | 6. Estuarine  | 11. Non-Forest     |
| 3. Riverine   | 7. Riverine   | 12. Agriculture    |
| 4. Lacustrine | 8. Lacustrine | 13. Developed Land |
|               | 9. Palustrine |                    |

Figure 2. The Maine Coast Ecosystem. The coast of Maine, north and east of Cape Elizabeth, is considered to be a discrete physiographic ecosystem. Three generalized habitat types are recognized: deepwater, wetland, and terrestrial. These habitats are further divided into systems, subsystems, and classes (Cowardin et al., 1977, Maine State Planning Office 1974).



MAINE COAST ECOSYSTEM

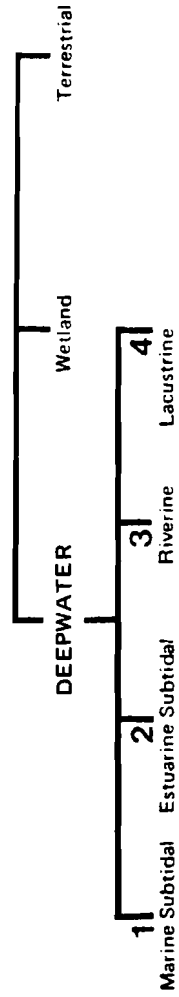

Figure 3. The Maine Coast Deepwater Habitat Systems. This generalized habitat type is made up of the Marine Subtidal, Estuarine Subtidal, Riverine, and Lacustrine Systems (Cowardin et al. 1977).



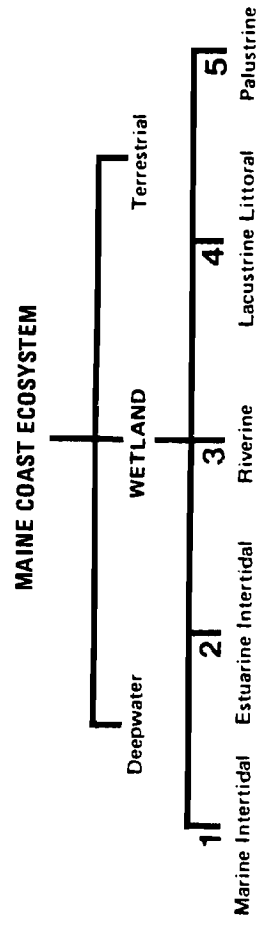
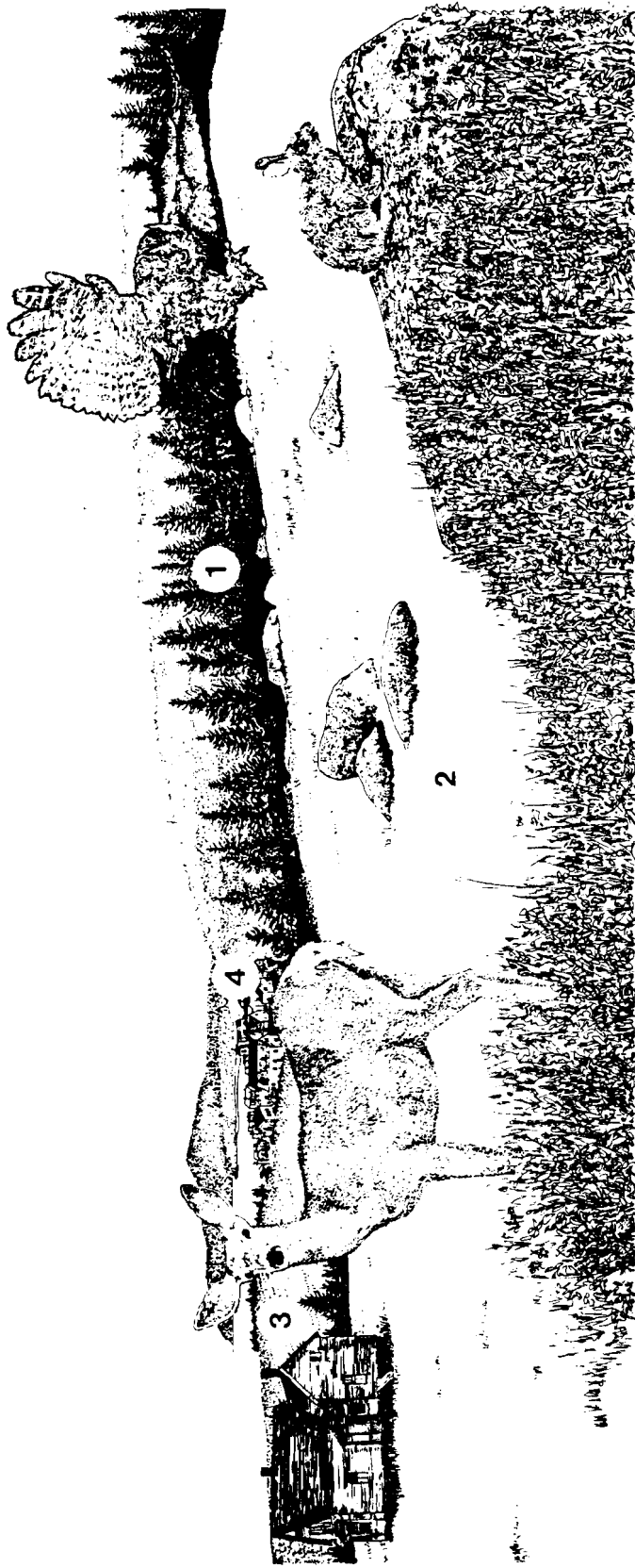

Figure 4. The Maine Coast Wetland Habitat Systems. This generalized habitat type is made up of the Marine Intertidal, Estuarine Intertidal, Riverine, Lacustrine, and Palustrine Systems (Cowardin et al. 1977).



MAINE COAST ECOSYSTEM

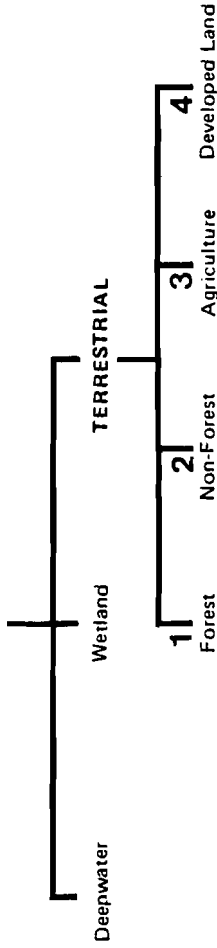

Figure 5. The Maine Coast Terrestrial Habitat Systems. This generalized habitat type is made up of the Forest, Non-Forest, Agriculture, and Developed Land Systems. There may be intergradations from one area to another which possess characteristics of two or more systems (Maine State Planning Office 1974).

basic laws which govern the behavior of energy. The conceptual energese model (fig. 6) illustrates the flow of energy through an ecological system. Figure 7 applies this energese model to the naturally occurring eelgrass community. Figure 8 further illustrates the relationship between the energy flow model and the natural system, in this case the intertidal emergent wetland.

2. Biogeochemicals—Elements and inorganic compounds, many of which are essential components for growth, circulate through the biosphere (soil, water, and air) in characteristic patterns known as biogeochemical cycles (fig. 9).

3. Abiotic factors—Essential environmental factors which make life possible on the surface of the earth are the constant interactions of geologic, climatic, hydrologic, and oceanographic changes.
4. Biotic factors—The biotic world is classified in respect to energy through trophic levels, each of which is one exchange step beyond the energy source which drives it (fig. 10). Web diagrams will be used to depict trophic levels and energy flows by using food webs as examples.

These concepts have been described by various prominent ecologists as being illustrative of the interactions within a system. H. T. Odum (1966)

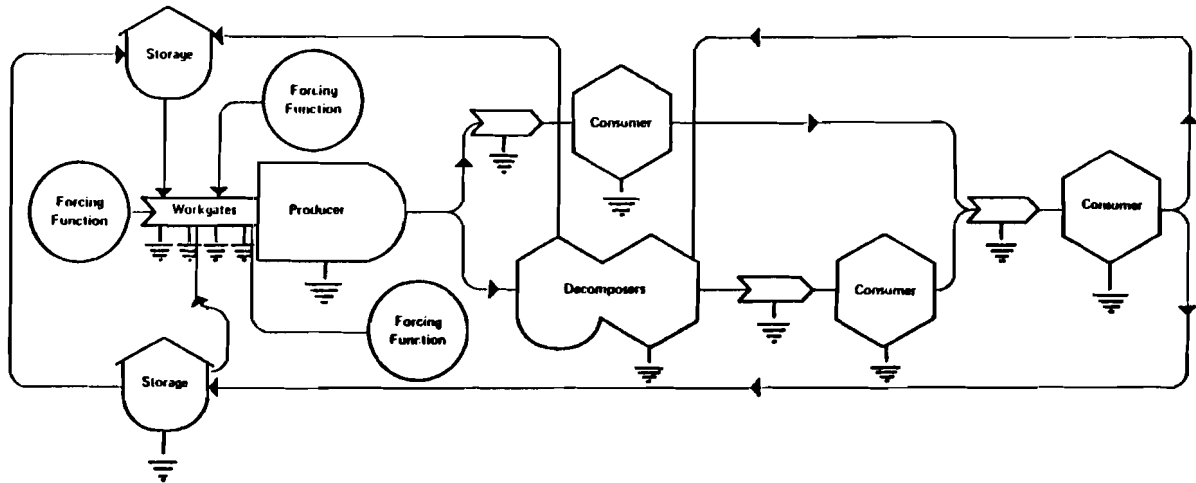

Figure 6. Conceptual energy flow model.

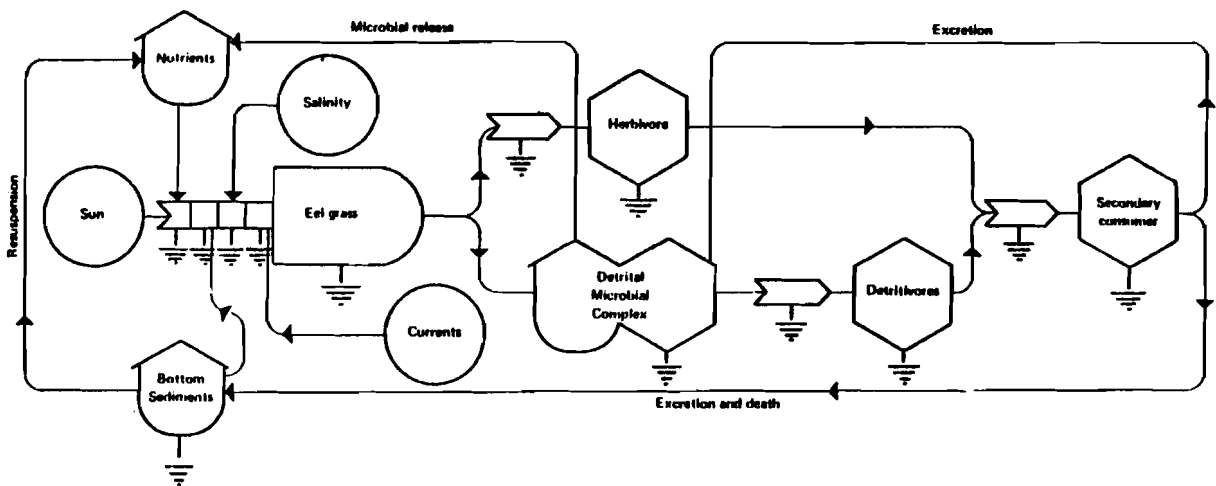

Figure 7. Energy flow model of a natural eelgrass community.

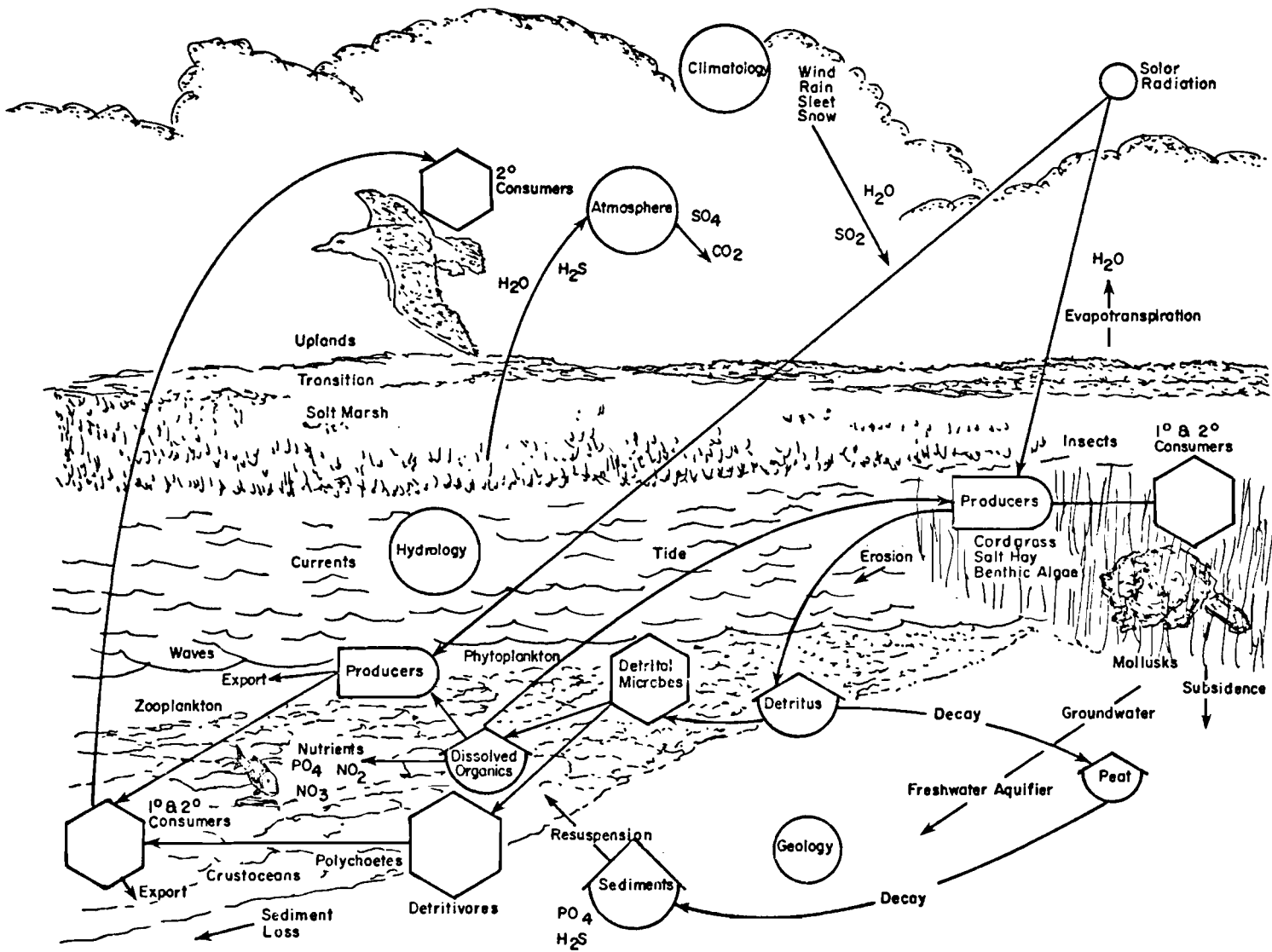

Figure 8. A simplified energy flow model typical of an estuarine system.

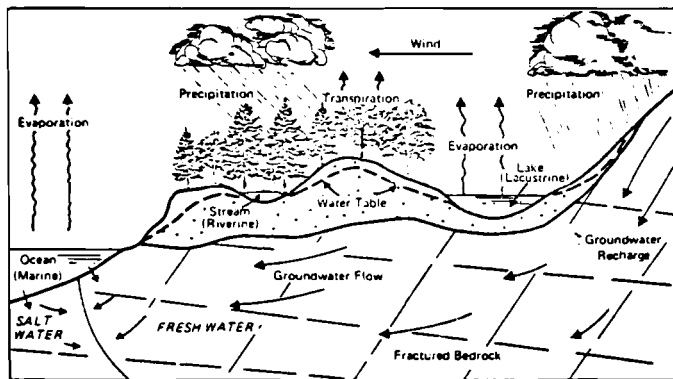

Figure 9. Conceptual model of the hydrologic cycle (adapted from Caswell 1977). Elements and inorganic compounds, many of which are essential components for the biota, circulate through the biosphere dissolved in waters.

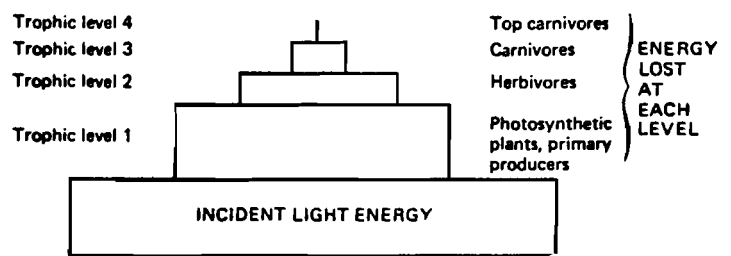

Figure 10. Simple trophic pyramid of energy (Odum 1971).

has developed the concept of energy flows and interactions, which can be illustrated through energy diagrams. This energy concept can be developed to a sophisticated science of quantitative ecological system modeling when such data are available (Hall and Day 1977). Flow diagrams can be used, for example, to translate an understanding of biogeochemical cycling which is essential to the appreciation of the interactions among living and nonliving components (Hutchinson 1944, 1950). Likens et al. (1977) have studied these cycles in depth and have quantified certain biogeochemical pathways in a terrestrial system in New Hampshire.

Food webs are used to illustrate interactions between the plant and animal components of a system. Abiotic factors interact to form the habitat templates governing the use of an area by the biota. Ecologists apply any one or combinations of the four primary concepts to illustrate and comprehend interactions in ecological systems; we have attempted to apply all of these concepts to illustrate interactions. It is important to realize that these concepts are not exclusive of each other but overlap and are complementary. Here they are applied to the ecosystems, systems, and classes found on the Maine coast and become the framework of the conceptual model (fig. 11).

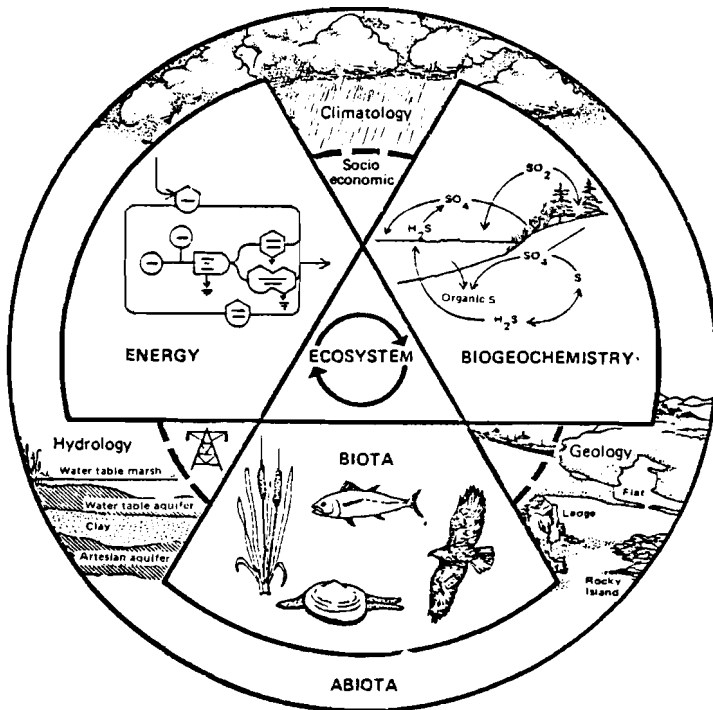

Figure 11. A conceptual model illustrating the interactions of the primary concepts applied to the Maine coast ecosystem.

## THE GROUPS-OF-INTEREST APPROACH

Another approach to understanding the Maine coast ecosystem is to translate an organism's dependency on and participation in the interactions previously discussed.

The ecosystem approach emphasizes the habitat as an entity. In the groups-of-interest approach, interrelationships between commercially and ecologically important groups of species and their environments are emphasized (fig. 12). The uses of habitats for various life stages, reproductive strategies as controlled by limiting factors, and the importance of man and management are discussed. Case studies illustrating the above concepts are included within the discussion of each group of interest.

This section complements the ecosystem approach in that it illustrates the varied needs of important organisms in terms of habitats and components of habitats.

## THE ATLAS

The Atlas presented as a volume of the report is to be used in conjunction with the text. Table 1 lists the contents of the Atlas. The specific maps and overlays illustrate locations of selected components and aid in directing interactions of driving forces and components.

Table 1. Overlays of the Maine Test Characterization Atlas

National Wetlands Inventory	High and low water
Land cover	Point sources
Marine geology	Named lakes with summarized data
Soils	Wetlands important to waterfowl; rivers evaluated for fisheries
Substrates	Migratory and anadromous fish
Sea bird, wading bird, shore bird, eagle, and osprey nest sites	Estuarine and riverine fish
Shellfishes, marine worms	Harbor seal haulout sites
Harbor seal haulout sites	Marine fish, lobsters
Tidal range, currents	

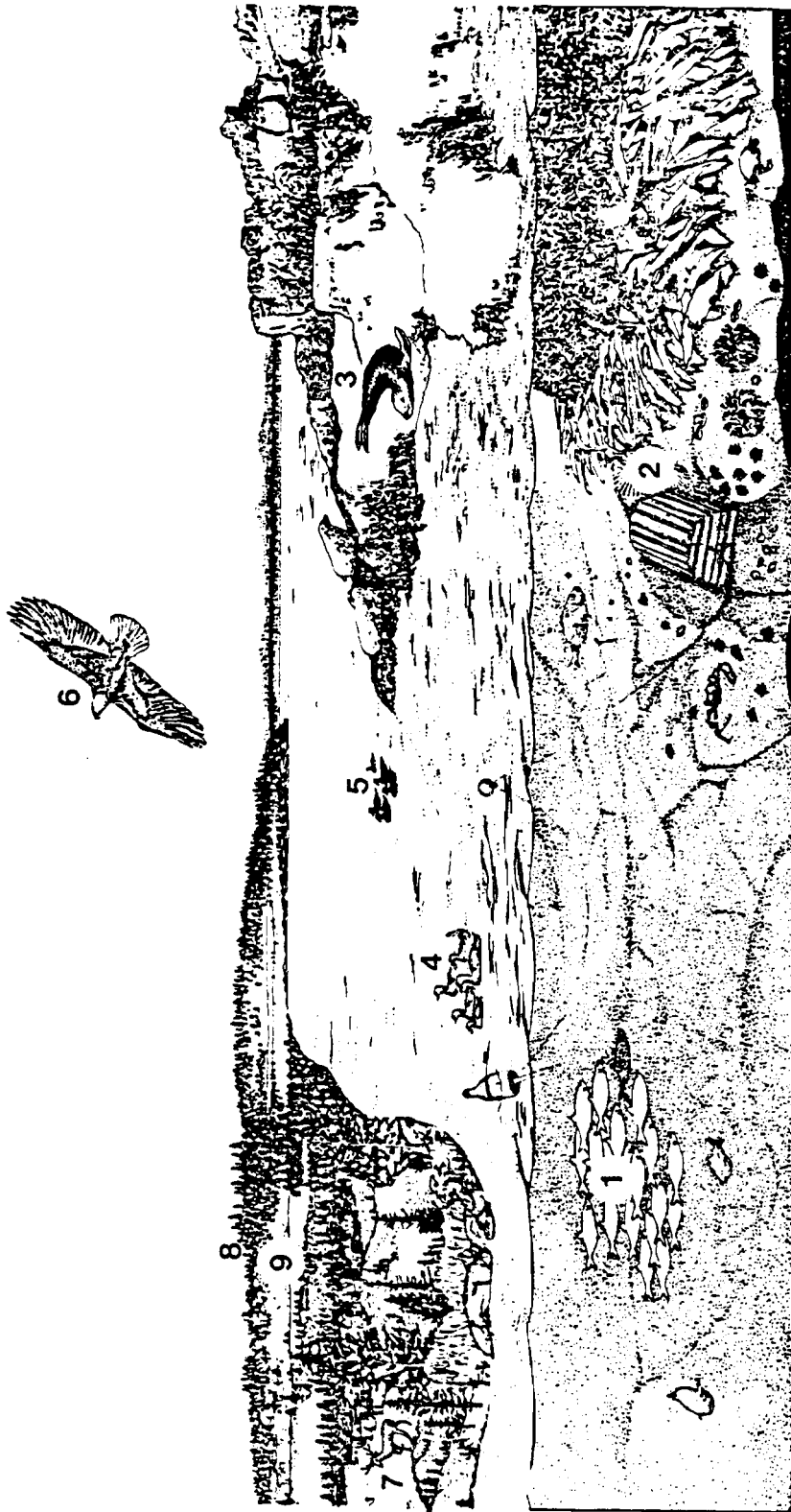

- 1 Finfish
- 2 Shellfish and Marine Worms
- 3 Marine Mammals
- 4 Seabirds, Wading Birds, Shorebirds
- 5 Waterfowl
- 6 Terrestrial Birds
- 7 Terrestrial Mammals
- 8 Commercially Important Trees
- 9 Threatened and Endangered Plants

Figure 12. Major groups of interest in the Maine coast ecosystem.

## DATA SOURCE APPENDIX

The Data Source Appendix, a computer-based information storage and retrieval system based on a key word index, is used to present data source reference information. It includes all information used for analysis in this characterization as well as general references that apply to the characterization; it is not an all-inclusive source of information dealing with resources of the Maine coast. Two lists of reference citations are provided. One list will present the citations in alphabetical order by author. The second list will arrange the citations by key words associated with the classification model; key words are presented in table 2.

## APPLICATIONS OF THE PRODUCTS

The products of the characterization could be used to gain an understanding of the entire Maine coast ecosystem. However, most users will be interested in a particular area, species, or group of species. The products are presented so that the needs of varied users are met.

A user interested in a particular area would look at Atlas maps to determine where the area fits into the classification model. The particular classification of concern would then be found in the Atlas text where components and interactions are discussed. It is recommended that the user start at the general level and work toward the specific for the most complete understanding of how the particular area interacts with others.

If the user is interested in a particular impact, table 3 should be used. This matrix informs the user of the impacts of selected human activities. After these impacts have been identified, table 4 can be used to see which systems are affected and how the biological and cultural factors may be impacted. A check indicates an interaction. Following the matrices will be an index of interactions with appropriate references to the characterization indicating where such impacts are discussed or implied.

For example, the effects of the paper and pulp industry are indicated in table 3 and include an increase in turbidity, a rise in temperature, changes in water and air composition, and the addition of nutrients, metals, and chemical pollutants. If the user then locates these physical and chemical effects on table 4, he will find that each of these effects has impacts upon biological and cultural

factors. An increase in chemical pollutants affects the terrestrial, wetland, and deepwater habitats, impacting upon phytoplankton, zooplankton, invertebrates, fish, birds, and mammals. Some of these effects are direct; others are indirect via a predator-prey or food web interaction. Reading further across the matrix, one then finds that wilderness areas, parks and refuges, fishing, swimming, bird watching, hunting, and aesthetics are also impacted. For specific discussions of any of these interactions, one would consult the index and refer to specific sections in the characterization.

A user interested in a particular species or group of species would refer to the group in the index where the appropriate Groups-of-Interest section and/or Systems section is listed. The Atlas maps referred to in the text should be studied to gain an understanding of the distribution and requirements of a species.

As an example: A utility is planning to site a liquid natural gas facility in a town. The user concerned with the planning of this development and associated support developments would refer to the Atlas to determine the class system or habitat the proposed developments could impact, i.e., what classification the area fits. The user would then be referred to appropriate Ecosystem, Habitat, and Systems sections. Application of the Atlas would augment the discussion so that interactions would be illustrated. The User's Guide matrix would direct the user to a listing of the general impacts anticipated from the proposed activities. These impacts are referred to in the index which would lead the user to pages in the text where the impacts on the particular system/species of concern are explained.

If specific information from the various sources is desired, the data sources and references are listed by habitats and species in the Data Source Appendix of the original report.

## LITERATURE CITED

- Caswell, W. B. 1977. Groundwater guidebook for State of Maine. Maine Geological Survey, open file report, Augusta, Maine. 202 pp.
- Clark, J. R. 1977. Coastal ecosystem management. A technical manual for the conservation of coastal zone resources. John Wiley and Sons, New York. 928 pp.

Table 2. Key Words Used in the Data Source Appendix

Agriculture	Hydrography	Pollution
Air quality	In-document	Populations
Algae	Industry	Precipitation
Bacteria	Insects	Predator-prey
Behavior	Intertidal	Production
Benthos	Invertebrates	Productivity
Biogeochemistry	Islands	Recreation
Biology	Lacustrine	Remote sensing
Birds	Land use	Reproduction
Chemistry	Legislation	Riverine
Climatology	Macroalgae	Rocky shore
Communities	Mammals	Salinity
Crustacea	Management	Sea birds
Deep water	Mapping	Sedimentation
Degradation	Marine	Sediments
Disease	Marine mammals	Shore birds
Dissolved oxygen	Marsh	Socioeconomic
Distributions	Methodology	Soil
Diversity	Microorganisms	Species interaction
Drainage	Molluscs	Subtidal
Ecology	Mortality	Temperature
Estuarine	Mud flat	Terrestrial
Fauna	Nitrogen	Terrestrial birds
Fisheries	Nutrients	Terrestrial mammals
Fishes	Nutrient cycling	Tides
Flooding	Nutritive value	Trophic relations
Flora	Oceanography	Vegetation
Food and feeding	Palustrine	Vertebrates
Forestry	Passerine	Wading birds
Freshwater	Perturbation	Water chemistry
Fungi	Pesticides	Waterfowl
General	Phosphorus	Water quality
Geology	Physical parameters	Wetlands
Harvest	Physiography	Wildlife
Heavy metals	Phytoplankton	Zonation
Herbicides	Plant ecology	Zooplankton
Hydrocarbons	Pollutant effects	



Table 3. Human-Imposed Alterations in the Environment

Physical & chemical changes in the environment	Land alteration & construction							
	Precon- struction activities	Impervious surfacing, earthworks (highways, pkg lots)	Drainage ditching	Building & industrial plant con- struction	Drainage structures	Tunnel construc- tion	Bridging	Dredging
Loss of habitat	X	X	X	X	X	X	X	X
Removal of vegetation	X	X	X	X	X			
Removal of topsoil	X	X	X	X	X			
Increase in surface runoff	X	X	X	X	X			
Increase in soil erosion	X	X	X	X	X			
Increase in slope grade	X	X	X	X	X			
Lowering of water table		X	X					
Loss of groundwater		X						
Alteration of drainage areas		X	X	X	X			
Modification of seasonal flow patterns		X						
Drastic fluctuations in water level & flow rates		X	X	X				
Reduction in flow volume		X						
Increase in downstream flooding		X	X					
Canal creation in wetlands		X	X	X	X		X	X
Increase in turbidity	X	X	X	X	X	X		X
Increase in sedimentation	X	X	X	X	X	X		X
Alteration of bottom topography		X						X
Reduction in light penetration		X						X
Elevation of temperature		X						X
Modification of chemical composition:								
Soil		X		X				
Water		X	X	X	X			
Air								
Increase in oxygen demand		X	X	X	X			X
Addition of nutrients		X	X	X	X			X
Addition of metals		X	X	X	X			X
Addition of chem. pollutants		X	X	X	X			X
Change in salinity		X	X	X	X			X
Disturbance (noise poll.)								

Table 3. (continued)

Physical & chemical changes in the environment	Land alteration & construction				Resource extraction		
	Fill construction	Powerlines/ pipeline	Dam construction		Mining	Lumbering	Oil & gas extraction
			Upstream	Downstream			
Loss of habitat	X	X	X	X	X	X	X
Removal of vegetation			X		X	X	
Removal of topsoil			X		X		
Increase in surface runoff					X	X	
Increase in soil erosion			X		X	X	
Increase in slope grade					X		
Lowering of water table					X		
Loss of groundwater					X		
Alteration of drainage areas			X		X		
Modification of seasonal flow patterns			X	X	X		
Drastic fluctuations in water level & flow rates			X	X	X	X	
Reduction in flow volume				X			
Increase in downstream flooding				X	X		
Canal creation in wetlands	X						
Increase in turbidity				X	X	X	X
Increase in sedimentation			X	X	X	X	X
Alteration of bottom topog.		X	X	X	X		
Reduction in light penetration			X	X	X	X	
Elevation of temperature			X	X	X		
Modification of chemical composition:							
Soil					X	X	
Water			X	X	X	X	
Air							
Increase in oxygen demand			X		X	X	
Addition of nutrients			X		X	X	
Addition of metals					X		
Addition of chem. pollutants					X		
Change in salinity				X			
Disturbances (noise poll.)							

Table 3. (continued)

Physical & chemical changes in the environment	Transportation					Recreation			Waste emplacement		
	Auto- mobile	Trucking	Shipping	Rail	Air	Boating	Snow mobiling	Landfill, spoil	Municipal discharge	Septic tank discharge	
Loss of habitat	X	X					X	X			
Removal of vegetation	X	X					X				
Removal of topsoil	X	X					X				
Increase in surface runoff.											
Increase in soil erosion											
Increase in slope grade									X		
Lowering of water table									X		
Loss of groundwater									X		
Alteration of drainage areas								X	X		
Modification of seasonal flow patterns						X		X	X	X	
Drastic fluctuations in water level & flow rates											
Reduction in flow volume											
Increase in downstream flooding											
Canal creation in wetlands											
Increase in turbidity			X			X			X	X	
Increase in sedimentation			X						X		
Alteration of bottom topog.											
Reduction in light penetration									X		
Elevation of temperature			X						X		
Modification of chemical composition:											
Soil											
Water			X					X	X	X	
Air	X				X			X			
Increase in oxygen demand											
Addition of nutrients			X						X	X	
Addition of metals			X						X	X	
Addition of chem. pollutants			X			X					
Change in salinity											
Disturbance (noise poll.)						X				X	

Table 3. (continued)

Physical & chemical changes in the environment	Waste emplacement				Industrial processing				
	Indus- trial discharge	Cooling water discharge	Lead shot (hunting)	Paper & pulp products	Grain milling & dairy products	Ship- building	Textiles	Steel works	Oil refining
Loss of habitat									X
Removal of vegetation									
Removal of topsoil									
Increase in surface runoff									
Increase in soil erosion									
Increase in slope grade									X
Lowering of water table									X
Loss of groundwater									
Alteration of drainage areas	X	X						X	X
Modification of seasonal flow patterns									
Drastic fluctuations in water level & flow rates									
Reduction in flow volume									
Increase in downstream flooding									
Canal creation in wetlands									
Increase in turbidity	X			X	X	X	X	X	X
Increase in sedimentation						X			X
Alteration of bottom topog.									
Reduction in light penetration									
Elevation of temperature		X		X	X			X	X
Modification of chemical composition:									
Soil									
Water	X	X		X		X		X	X
Air				X	X	X	X	X	X
Increase in oxygen demand				X	X	X	X	X	X
Addition of nutrients	X			X	X	X	X	X	X
Addition of metals	X			X	X	X	X	X	X
Addition of chem. pollutants				X	X	X	X	X	X
Change in salinity				X	X				
Disturbance (noise poll.)				X					

Table 3. (continued)

Physical & chemical changes in the environment	Industrial processing			Agricultural processing				Catastrophic events	
	Metal finishing	Meat & poultry	Electric steam power production	Agri- culture	Aqua- culture	Weed control	Insect control	Oil spills and leaks	Chemical spills
Loss of habitat				X					
Removal of vegetation				X					
Removal of topsoil				X					
Increase in surface runoff									
Increase in soil erosion									
Increase in slope grade									
Lowering of water table									
Loss of groundwater									
Alteration of drainage areas				X					
Modification of seasonal flow patterns	X	X	X	X					
Drastic fluctuations in water level & flow rates									
Reduction in flow volume									
Increase in downstream flooding									
Canal creation wetlands	X	X	X					X	
Increase in turbidity		X							
Increase in sedimentation		X							
Alteration of bottom topog.									
Reduction in light penetration									
Elevation of temperature		X	X					X	
Modification of chemical composition:									
Soil				X					
Water	X	X	X	X	X	X		X	X
Air	X		X						
Increase in oxygen demand		X							
Addition of nutrients	X	X	X	X	X				
Addition of metals			X						
Addition of chem. pollutants			X						
Change in salinity				X		X		X	X
Disturbance (noise poll.)									

Table 3. (concluded)

Physical & chemical changes in the environment	Catastrophic events		
	Explosions	Floods	Droughts
Loss of habitat	X	X	X
Removal of vegetation			
Removal of topsoil		X	
Increase in surface runoff		X	
Increase in soil erosion			
Increase in slope grade			
Lowering of water table			X
Loss of groundwater			X
Alteration of drainage areas		X	
Modification of seasonal flow patterns		X	X
Drastic fluctuations in water level & flow rates		X	
Reduction in flow volume			X
Increase in downstream flooding		X	
Canal creation in wetlands			
Increase in turbidity		X	
Increase in sedimentation		X	
Alteration of bottom topog.			
Reduction in light penetration			
Elevation of temperature			
Modification of chemical composition:			
Soil		X	X
Water		X	X
Air			
Increase in oxygen demand			
Addition of nutrients			
Addition of metals			
Addition of chem. pollutants			
Change in salinity			X
Disturbance (noise poll.)			

Table 4. Associated Biological and Cultural Effects

Physical & chemical changes in the environment	Habitat affected				Biological factors					
	Terres- trial	Wetland	Deepwater	Phyto- plankton	Vascular plants	Trees	Zoo- plankton	Benthic inverte- brates	Insects	
Loss of habitat	X	X	X	X	X	X	X	X	X	
Removal of vegetation	X	X			X	X				
Removal of topsoil	X	X			X	X				
Increase in surface runoff	X	X	X	X						
Increase in soil erosion	X	X			X	X			X	
Increase in slope grade	X	X			X	X			X	
Lowering of water table	X	X	X		X	X			X	
Loss of groundwater	X	X			X	X			X	
Alteration of drainage areas	X	X			X	X			X	
Modification of seasonal flow patterns		X	X	X			X	X		
Drastic fluctuations in water level & flow rates		X	X	X			X	X		
Reduction in flow volume		X	X	X	X	X			X	
Increase in downstream flooding	X	X	X		X	X			X	
Canal creation wetlands		X	X		X	X			X	
Increase in turbidity		X	X	X			X	X		
Increase in sedimentation		X	X	X			X	X		
Alteration of bottom topog.		X	X	X			X	X		
Reduction in light penetration		X	X	X			X	X		
Elevation of temperature		X	X	X	X	X				
Modification of chemical composition:										
Soil	X	X	X		X	X	X		X	
Water		X	X	X	X	X	X	X	X	
Air	X	X	X	X	X	X	X	X	X	
Increase in oxygen demand		X	X	X	X	X	X	X		
Addition of nutrients		X	X	X	X	X	X	X		
Addition of metals		X	X	X	X	X	X	X		
Addition of chem. pollutants	X	X	X	X	X	X	X	X		
Change in salinity		X	X	X	X	X	X	X	X	
Disturbance (noise poll.)	X	X	X	X	X	X	X	X	X	

Table 4. (continued)

Physical & chemical changes in the environment	Biological factors				Ecological relationship				
	Fish	Amphibians & reptiles	Birds	Mammals	Predator- prey	Compe- tition	Food web	Habitat diversity	Produc- tivity
Loss of habitat	X	X	X	X	X	X	X	X	X
Removal of vegetation		X	X	X	X	X	X	X	X
Removal of topsoil				X					
Increase in surface runoff				X	X		X	X	X
Increase in soil erosion		X							
Increase in slope grade		X	X	X		X	X		X
Lowering of water table						X			
Loss of groundwater						X			
Alteration of drainage areas		X		X				X	
Modification of seasonal flow patterns	X	X			X		X		X
Drastic fluctuations in water level & flow rates	X	X					X		
Reduction in flow volume	X	X			X		X		
Increase in downstream flooding	X	X	X	X			X		
Canal creation in wetlands	X	X					X	X	X
Increase in turbidity	X				X	X	X	X	X
Increase in sedimentation	X				X	X	X	X	X
Alteration of bottom topog.	X				X		X	X	
Reduction in light penetration	X				X	X	X		X
Elevation of temperature	X						X		
Modification of chemical composition:									
Soil		X		X			X	X	X
Water	X	X	X	X			X	X	X
Air			X						
Increase in oxygen demand	X	X	X	X			X	X	X
Addition of nutrients	X	X	X	X	X		X		
Addition of metals	X		X	X	X		X		
Addition of chem. pollutants	X		X	X	X		X		
Change in salinity	X						X		X
Disturbance (noise poll.)			X						



Table 4. (Concluded)

Physical & chemical changes in the environment	Ecological relationship			Cultural factors						
	Eutro- phication	Nutrient & other cycles	Wil- derness areas	Parks & refuges	Fishing	Boating	Swimming	Bird watching	Hunting	Aesthetics
Loss of habitat		X	X	X	X	X		X	X	X
Removal of vegetation			X	X				X	X	X
Removal of topsoil			X	X				X	X	X
Increase in surface runoff			X	X					X	X
Increase in soil erosion			X	X						X
Increase in slope grade			X	X						
Lowering of water table			X	X						
Loss of groundwater			X	X						
Alteration of drainage areas			X	X		X				
Modification of seasonal flow patterns			X	X	X	X	X			
Drastic fluctuations in water level & flow rates			X	X	X	X	X			X
Reduction in flow volume			X	X	X	X	X			
Increase in downstream flooding			X	X	X	X	X	X	X	X
Canal creation in wetlands			X	X						
Increase in turbidity	X	X			X	X	X			X
Increase in sedimentation	X	X			X	X	X			X
Alteration of bottom topog.		X			X	X	X			X
Reduction in light penetration					X	X	X			
Elevation of temperature					X	X	X			
Modification of chemical composition:										
Soil		X	X	X	X	X	X	X	X	X
Water		X	X	X	X	X	X	X	X	X
Air		X	X	X	X	X	X	X	X	X
Increase in oxygen demand	X				X	X	X	X	X	X
Addition of nutrients	X	X	X	X	X	X	X	X	X	X
Addition of metals		X	X	X	X	X	X	X	X	X
Addition of chem. pollutants		X	X	X	X	X	X	X	X	X
Change in salinity					X	X	X	X	X	X
Disturbance (noise poll.)									X	X

## LITERATURE CITED (CONTINUED)

- Cowardin, L. M., U. Carter, F. C. Golet, and E. T. LaRoe. 1977. Classification of wetlands and deepwater habitats of the United States (an operational draft). U.S. Fish and Wildlife Service. 100 pp. (mimeo).
- Hall, C. A., and J. W. Day, Jr. 1977. Ecosystem modeling in theory and practice: an introduction with case histories. John Wiley and sons, New York. 684 pp.
- Hutchinson, G. E. 1944. Limnological studies in Connecticut. Critical examination of the supposed relationship between phytoplankton periodicity and chemical changes in lake waters. *Ecology* 25:3-26.
- \_\_\_\_\_. 1950. Survey of contemporary knowledge of biogeochemistry. III. The biogeochemistry of vertebrate excretion. *Bull. Amer. Mus. Nat. Hist.* 96:554.
- Likens, G. E., F. H. Bormann, J. S. Eaton, and N. M. Johnson. 1977. Biogeochemistry of a forested ecosystem. Springer-Verlag, New York. 146 pp.
- Maine State Planning Office. 1974. Standard classification system for land cover in Maine. 26 pp.
- Moen, A. N. 1973. Wildlife ecology: an analytical approach. W. H. Freeman and Co., San Francisco.
- Odum, E. P. 1971. Fundamentals of ecology, 3rd ed. W. B. Saunders Co., Philadelphia. 574 pp.
- Odum, H. T. 1966. Primary production in flowing waters. *Limnol. Oceanogr.* 1:102-117.
- Shelford, V. E. 1963. The ecology of North America. Univ. Illinois Press, Urbana.
- Van Dyne, G. M., ed. 1969. The ecosystem concept in natural resource management. Academic Press, New York. 383 pp.