

---

Biological Report 85(7.2)  
May 1985

# **The Ecology of Giant Kelp Forests in California: A Community Profile**

---

Fish and Wildlife Service  
U.S. Department of the Interior

This is one of the first reports to be published in the new "Biological Report" series. This technical report series, published by the Research and Development branch of the U.S. Fish and Wildlife Service, replaces the "FWS/OBS" series published from 1976 to September 1984. The Biological Report series is designed for the rapid publication of reports with an application orientation, and it continues the focus of the FWS/OBS series on resource management issues and fish and wildlife needs.

Biological Report 85(7.2)  
May 1985

**THE ECOLOGY OF GIANT KELP FORESTS  
IN CALIFORNIA: A COMMUNITY PROFILE**

by

Michael S. Foster

and

David R. Schiel  
Moss Landing Marine Laboratories  
P.O. Box 450  
Moss Landing, CA 95039-0450

Project Officer  
Wiley M. Kitchens  
National Coastal Ecosystems Team  
U.S. Fish and Wildlife Service  
1010 Gause Boulevard  
Slidell, LA 70458

Prepared for

National Coastal Ecosystems Team  
Division of Biological Services  
Research and Development  
U.S. Fish and Wildlife Service  
NASA-Slidell Computer Complex  
1010 Gause Boulevard  
Slidell, LA 70458

DISCLAIMER

The mention of trade names does not constitute endorsement or recommendation for use by the Federal Government.

Library of Congress No. 84-60117.

This report should be cited as:

Foster, M.S., and D.R. Schiel. 1985. The ecology of giant kelp forests in California: a community profile. U.S. Fish Wildl. Serv. Biol. Rep. 85(7.2). 152 pp.

## PREFACE

Submarine forests of giant kelp (Macrocystis), with plants over 50 m tall growing from the bottom to the surface of the sea, probably intrigued humans long before the first published insights into their ecology by Darwin in 1860. Even with only a limited view from the surface and observations from collections, Darwin was clearly fascinated by giant kelp and the diverse organisms associated with it, and made the first analogy between this community and terrestrial forests. Except for a few subsequent reports on the extent of the Macrocystis resource in California, it was almost a hundred years after Darwin's observations in South America that the study of California kelp forests began. Andrews' (1945) pioneering research on the fauna of giant kelp holdfasts included some underwater observations, but this and other early studies were hampered by the lack of simple diving equipment. With the advent of SCUBA in the early 1950's, direct observations of kelp forests became relatively simple and, because of mounting concern over the effects of sewage discharges, loss of kelp habitat, and possible impacts of kelp harvesting, a number of kelp research programs were started. Thus, giant kelp communities have been examined in detail for only slightly more than 30 years. The objectives of this profile are to review and summarize what is known about kelp forests, with emphasis on Macrocystis pyrifera communities in California, and to suggest future research needs and approaches necessary to improve our understanding of the ecology of these complex communities.

Cowardin et al. (1979) classified these habitats as occurring in the Californian Province, marine system, subtidal subsystem, aquatic bed class,

algal bed subclass, and Macrocystis dominance type. Although we recognize the need for such a classification system, much of the recent work on kelp communities emphasizes their considerable natural variation. Thus, within a particular forest there may be areas of rock bottom class and unconsolidated class with most associated subclasses (bedrock, rubble, cobble-gravel, sand) and with various dominance types (Laminaria, Pterygophora, various red algae, various invertebrates); the classification of a particular area may change with time. The modifiers used by Cowardin et al. (1979) are less variable in kelp forests; the water regime is almost always subtidal, and the water chemistry is euhaline. We have restricted our detailed review to M. pyrifera forests in California (including the Pacific coast of Baja California, Mexico) because this section of coastline includes the entire geographic range of the plant in the northern hemisphere (see Chapter 1), because the environment within this range is more similar than between it and other geographic areas, and because most research has been done here. In addition, the majority of the profile is devoted to Macrocystis itself because we know more about it than other species in the community, because it defines the subject of the profile, and because our own work has focused on it and associated plants.

To accomplish the above objectives, we have attempted to review most of the available literature on California kelp forests, and to compare and contrast this information with relevant studies on kelp forests and beds in other areas. Most of the early work on Macrocystis in California is reviewed in North (1971a). We acknowledge the pioneering work of Wheeler J. North, and have relied heavily

on North's publications for information prior to 1971, and have also focused on reviewing more current information.

Chapter 1 discusses the aims and organization of the profile in more detail, and introduces the biology and ecology of surface canopy kelps, especially Macrocystis pyrifera. Physical, chemical, and geological aspects of the kelp forest environment are reviewed in Chapter 2. Chapter 3 describes community structure and energetics, while Chapter 4 reviews the natural history of organisms in the community. Chapter 5 points out some of the problems with our present understanding of kelp forest ecology, suggests research approaches that might solve these problems, and critically examines some current hypotheses concerning community structure and dynamics. Chapter 6 examines resource use, management, and pollution. Chapter 7 is a brief summary and outlines research and management needs.

Much of the work reviewed concerns ecology and natural history and, as a result, the information available is not always for a species. In Chapter 6 especially, taxonomic levels from species (e.g., Strongylocentrotus franciscanus) to combined phyla (e.g., sessile invertebrates) may be discussed in the same paragraph. Although this is an uneven treatment, it accurately reflects the state of information for particular organisms. Species are indicated where possible. In addition, because many users of this profile may be unfamiliar with

local species, we have used widely accepted common names, if available. The scientific name is given with the common name when the latter is first used. Abbott and Hollenberg (1976; algae), Morris et al. (1980; invertebrates) and Miller and Lea (1972; fish) were used for names unless otherwise noted in the text.

The results of much kelp forest research, particularly habitat surveys and management problems, are published in reports that are often cited, but generally unreviewed and difficult to obtain. Such reports and other secondary scientific publications (theses, unpublished manuscripts, etc.; see Day 1983 for the definitions of "scientific papers") often contain much useful information and are frequently cited in this profile. The interested reader should obtain and evaluate these publications before using the information summarized from them in this profile. The names and addresses of persons cited as personal communications follow the references.

Comments on, or requests for, this profile should be addressed to:

Information Transfer Specialist  
National Coastal Ecosystems Team  
U.S. Fish and Wildlife Service  
NASA-Slidell Computer Complex  
1010 Gause Boulevard  
Slidell, LA 70458  
504-255-6511, FTS 685-6511.

## CONTENTS

	<u>Page</u>
PREFACE . . . . .	iii
FIGURES . . . . .	x
TABLES . . . . .	xii
PLATES . . . . .	xiii
CONVERSION TABLE . . . . .	xiv
ACKNOWLEDGMENTS . . . . .	xv
CHAPTER 1 INTRODUCTION . . . . .	1
1.1 Taxonomy, Definitions, and Descriptions . . . . .	2
1.2 Distribution . . . . .	4
1.3 Kelp Forest Ecology . . . . .	5
CHAPTER 2 THE ABIOTIC ENVIRONMENT . . . . .	9
2.1 Introduction . . . . .	9
2.2 Substratum and Sedimentation . . . . .	9
2.3 Temperature . . . . .	11
2.4 Light . . . . .	12
2.5 Nutrients . . . . .	15
2.6 Water Motion . . . . .	17
CHAPTER 3 THE GIANT KELP COMMUNITY . . . . .	20
3.1 Introduction . . . . .	20
3.2 Distribution Along the Pacific Coast of North America . . . . .	22
3.2.1 Giant Kelp Forests . . . . .	22
3.2.2 Other Kelp Forests . . . . .	23
3.3 Distributional Variation Among Sites . . . . .	23
3.3.1 Central California . . . . .	26
3.3.2 Southern California . . . . .	28
3.3.3 Other Geographic Areas . . . . .	31
3.4 Distributional Variation Within Sites . . . . .	32
3.4.1 Between Depths . . . . .	32
3.4.2 Within Depths . . . . .	32
3.5 Temporal Variations in Community Structure . . . . .	33
3.5.1 Long-Term . . . . .	33
3.5.2 Short-Term . . . . .	34
3.5.3 Succession . . . . .	34

	<u>Page</u>
3.6 Biomass, Productivity, and Energy Flow . . . . .	35
3.6.1 Introduction. . . . .	35
3.6.2 Biomass (Standing Stocks) . . . . .	35
3.6.3 Primary Productivity. . . . .	37
3.6.4 Energy Flow - Food Webs . . . . .	39
CHAPTER 4 NATURAL HISTORY AND ECOLOGY OF KELP FOREST ORGANISMS . . . . .	43
4.1 Introduction . . . . .	43
4.2 Plankton and Decomposers . . . . .	43
4.2.1 Phytoplankton . . . . .	44
4.2.2 Zooplankton . . . . .	45
4.3 Macroscopic Plants . . . . .	45
4.3.1 Introduction. . . . .	45
4.3.2 Species That Form Surface Canopies: Kelp Forests . . . . .	46
4.3.2.1 <u>Macrocystis</u> . . . . .	46
4.3.2.2 Other Species That Form Surface Canopies in California and Mexico . . . . .	48
4.3.2.3 Surface Canopy Species in Other Areas . . . . .	49
4.3.3 Understory Canopy Species: Kelp Beds . . . . .	49
4.3.3.1 Species in California and Mexico. . . . .	49
4.3.3.2 Species in Other Areas. . . . .	50
4.3.4 Bottom Canopy Species . . . . .	52
4.3.4.1 Fleshy and Filamentous Species. . . . .	52
4.3.4.2 Articulated Corallines. . . . .	53
4.3.5 Encrusting Species. . . . .	54
4.3.6 Epiphytes . . . . .	55
4.4 Invertebrates. . . . .	55
4.4.1 Introduction. . . . .	55
4.4.2 Filter, Suspension, and Detritus Feeders. . . . .	56
4.4.2.1 Sponges . . . . .	56
4.4.2.2 Cnidarians. . . . .	56
4.4.2.3 Bryozoans . . . . .	57
4.4.2.4 Brittle Stars, Sea Stars, Sea Cucumbers and Sea Urchins . . . . .	58
4.4.2.5 Molluscs. . . . .	58
4.4.2.6 Polychaete Worms. . . . .	59
4.4.2.7 Sipunculans . . . . .	59
4.4.2.8 Crustaceans . . . . .	59
4.4.2.9 Tunicates . . . . .	60



	<u>Page</u>
4.4.3 Grazers . . . . .	61
4.4.3.1 Sea Urchins and Sea Stars . . . . .	61
4.4.3.2 Molluscs. . . . .	64
4.4.3.3 Crustaceans . . . . .	65
4.4.4 Predators . . . . .	66
4.4.4.1 Sea Stars . . . . .	66
4.4.4.2 Molluscs. . . . .	68
4.4.4.3 Crustaceans . . . . .	69
4.5 Fish . . . . .	69
4.5.1 Introduction. . . . .	69
4.5.2 Canopy-midwater Species . . . . .	70
4.5.3 Bottom Species. . . . .	73
4.5.4 Other Species . . . . .	75
4.6 Birds and Mammals. . . . .	76
4.6.1 Birds . . . . .	76
4.6.1.1 Introduction. . . . .	76
4.6.1.2 Kelp Forests. . . . .	76
4.6.1.3 Drift Kelp. . . . .	79
4.6.1.4 Kelp Wrack. . . . .	79
4.6.2 Marine Mammals. . . . .	80
4.6.2.1 Introduction. . . . .	80
4.6.2.2 Sea Otter . . . . .	80
4.6.2.3 Cetaceans . . . . .	82
4.6.2.4 Pinnipeds . . . . .	83
4.6.2.5 Steller's Sea Cow . . . . .	83
4.7 Diseases . . . . .	83
4.7.1 Introduction. . . . .	83
4.7.2 Macroalgae. . . . .	84
4.7.3 Invertebrates . . . . .	84
4.7.4 Vertebrates . . . . .	85
CHAPTER 5 HYPOTHESES CONCERNING COMMUNITY STRUCTURE AND DYNAMICS . .	89
5.1 Introduction . . . . .	89
5.2 Effects of Temperature . . . . .	91
5.3 Effects of Water Motion. . . . .	93
5.4 Other Abiotic Factors. . . . .	93
5.4.1 Depth Distribution. . . . .	93
5.4.2 Variability Within Depths . . . . .	95

	<u>Page</u>
5.5 Effects of Competition . . . . .	97
5.5.1 Canopy Removals . . . . .	97
5.5.2 Density of <u>Macrocystis</u> Stands . . . . .	99
5.5.3 Spore Dispersal . . . . .	100
5.6 Effects of Grazing . . . . .	101
5.6.1 Invertebrate Grazers (other than sea urchins) . . . . .	102
5.6.2 Effects of Fish . . . . .	102
5.6.3 Sea Urchins . . . . .	103
5.7 Indirect Effects: Sea Otter Foraging. . . . .	106
CHAPTER 6 HUMAN USE, MANAGEMENT, AND POLLUTION . . . . .	108
6.1 Introduction: Management and Management Agencies. . . . .	108
6.2 Commercial Resource Harvesting . . . . .	109
6.2.1 Plants. . . . .	109
6.2.1.1 <u>Macrocystis</u> . . . . .	109
6.2.1.2 Other Plants. . . . .	110
6.2.2 Animals . . . . .	111
6.2.2.1 Fishes. . . . .	111
6.2.2.2 Abalone . . . . .	111
6.2.2.3 Sea Urchins . . . . .	112
6.2.2.4 Lobsters. . . . .	112
6.2.3 Habitat Use . . . . .	113
6.3 Recreational Use . . . . .	113
6.3.1 Sport Fishing . . . . .	113
6.3.2 Other Recreational Activities . . . . .	113
6.3.3 Governmentally Regulated Areas. . . . .	113
6.4 Scientific Use . . . . .	114
6.5 Pollution - Man-Caused Environmental Change Other Than Fishing. . . . .	114
6.5.1 Pollution From Commercial, Recreational, and Scientific Use. . . . .	114
6.5.2 Coastal and Inland Construction . . . . .	114
6.5.3 Oil . . . . .	114
6.5.4 Power Plant Discharge and Intake. . . . .	115
6.5.5 Sewage Discharge. . . . .	116
6.6 Kelp Forest Restoration and the Creation of New Kelp Forests .	117

	<u>Page</u>
6.6.1 Restoration . . . . .	117
6.6.2 Creating New Kelp Forests . . . . .	118
6.7 Endangered Species . . . . .	119
CHAPTER 7 SUMMARY. . . . .	121
7.1 Overview and Generalizations . . . . .	121
7.2 Management Recommendations . . . . .	123
7.3 Research Needs . . . . .	124
REFERENCES. . . . .	125
1. Publications. . . . .	125
2. Addresses of Persons Cited as Personal Communication. . . . .	150

## FIGURES

<u>Number</u>		<u>Page</u>
1	The morphology and life history of <u>Macrocystis</u> . . . . .	3
2	The geographic distribution of the species of <u>Macrocystis</u> . . . . .	5
3	The distribution of common seaweeds within giant kelp forests . . . . .	6
4	Water motion produced by swells in shallow water. . . . .	17
5	Factors, factor interactions, and regulatory pathways affecting the algal associations in two giant kelp forests. . . . .	19
6	Cross-section showing the inhabitants of a generalized giant kelp forest. . . . .	21
7	The distribution of algae that form surface canopies in the north-east Pacific. . . . .	22
8	Location of the ten kelp forests described in Chapter 3 . . . . .	23
9	The distribution of conspicuous plants and animals found in five central California kelp forests . . . . .	24
10	The distribution of conspicuous plants and animals found in five southern California kelp forests. . . . .	25
11	A generalized food web for a kelp forest. . . . .	40
12	A food web for the Point Cabrillo kelp forest . . . . .	41
13	Generalized control web of factors and interactions affecting the distribution and abundance of organisms in a kelp forest. . . . .	42
14	Common benthic diatoms and a mysid shrimp . . . . .	44
15	A survivorship curve for <u>Macrocystis pyrifera</u> . . . . .	47
16	Colonization times for the more abundant algal species that recruited to artificial substrata in a kelp forest at Santa Cruz Island. . . . .	53
17	Common understory algae . . . . .	54
18	Relationship between the canopy cover of <u>Macrocystis</u> and upright (non-encrusting) understory algal cover . . . . .	54

<u>Number</u>		<u>Page</u>
19	Invertebrate filter, suspension, and detritus feeders common in kelp forests . . . . .	56
20	Common invertebrate grazers in kelp forests. . . . .	60
21	Some common invertebrate predators in kelp forests . . . . .	68
22	Some common kelp forest fishes . . . . .	70
23	Birds commonly associated with kelp forests. . . . .	78
24	Marine mammals associated with kelp forests. . . . .	80
25	The gauntlet of <u>Macrocystis</u> life history stages. . . . .	90
26	Kelp forest dynamics and temporal and spatial scales . . . . .	91
27	Temperature and irradiance recorded on the bottom in a <u>Macro-</u> <u>cystis</u> forest over a 4-year period . . . . .	92
28	Field station used for <u>Macrocystis pyrifera</u> gametophyte outplants. . . . .	94
29	Irradiance-temperature response surface for <u>Macrocystis pyrifera</u> sporophyte recruitment . . . . .	96
30	Kelp harvesting ship . . . . .	109
31	Aerial photograph of oil spill in a giant kelp canopy. . . . .	115

## TABLES

<u>Number</u>		<u>Page</u>
1	Factors influencing kelp forest algal populations . . . . .	7
2	Light levels for compensation and saturation of growth in various stages of <u>Macrocystis</u> . . . . .	13
3	Known nutrient requirements for <u>Macrocystis pyrifera</u> . . . . .	15
4	Kelp forest biomass . . . . .	36
5	<u>Macrocystis</u> net primary productivity. . . . .	38
6	Common invertebrate grazers . . . . .	62
7	Concentration and biomass of two sea urchin species across a grazing band. . . . .	64
8	Common invertebrate predators found in <u>Macrocystis</u> forests. . . .	66
9	Subhabitat and feeding categories of common kelp forest fishes. .	71
10	Birds of kelp forests . . . . .	77
11	Outline of a factorial laboratory experiment. . . . .	97
12	Abalone, lobster, and sea urchin landings in California . . . .	112

## PLATES

<u>Number</u>		<u>Page</u>
	A giant kelp forest at Santa Catalina Island . . . . .	Cover
1A	<u>Macrocystis</u> surface canopy near Santa Barbara. . . . .	87
1B	Infra-red aerial photograph of <u>Macrocystis</u> (orange) canopy in Carmel Bay. . . . .	87
1C	<u>Macrocystis</u> forest with numerous fish beneath the surface canopy. . . . .	87
1D	<u>Pelagophycus porra</u> at Santa Catalina Island. . . . .	87
1E	Understory canopy of <u>Pterygophora californica</u> . . . . .	87
1F	The articulated coralline alga <u>Calliarthron</u> , and the purple- ringed top shell <u>Calliostoma annulatum</u> . . . . .	87
2A	The lined chiton <u>Tonicella lineata</u> on an encrusting coralline alga. . . . .	88
2B	Cup corals and the cobalt sponge <u>Hymenamphiastra</u> . . . . .	88
2C	Various tunicates and sponges on a vertical wall within a kelp forest. . . . .	88
2D	Red sea urchins surrounded by various foliose red algae . . . .	88
2E	<u>Pisaster giganteus</u> and a group of strawberry anemones, <u>Cory- nactis californica</u> . . . . .	88
2F	The hydrocoral <u>Allopora californica</u> . . . . .	88

## CONVERSION TABLE

### Metric to U.S. Customary

<u>Multiply</u>	<u>By</u>	<u>To Obtain</u>
millimeters (mm)	0.03937	inches
centimeters (cm)	0.3937	inches
meters (m)	3.281	feet
kilometers (km)	0.6214	miles
square meters (m <sup>2</sup> )	10.76	square feet
square kilometers (km <sup>2</sup> )	0.3861	square miles
hectares (ha)	2.471	acres
liters (l)	0.2642	gallons
cubic meters (m <sup>3</sup> )	35.31	cubic feet
cubic meters	0.0008110	acre-feet
milligrams (mg)	0.00003527	ounces
grams (g)	0.03527	ounces
kilograms (kg)	2.205	pounds
metric tons (t)	2205.0	pounds
metric tons	1.102	short tons
kilocalories (kcal)	3.968	British thermal units
Celsius degrees	1.8(°C) + 32	Fahrenheit degrees

### U.S. Customary to Metric

inches	25.40	millimeters
inches	2.54	centimeters
feet (ft)	0.3048	meters
fathoms	1.829	meters
miles (mi)	1.609	kilometers
nautical miles (nmi)	1.852	kilometers
square feet (ft <sup>2</sup> )	0.0929	square meters
acres	0.4047	hectares
square miles (mi <sup>2</sup> )	2.590	square kilometers
gallons (gal)	3.785	liters
cubic feet (ft <sup>3</sup> )	0.02831	cubic meters
acre-feet	1233.0	cubic meters
ounces (oz)	28.35	grams
pounds (lb)	0.4536	kilograms
short tons (ton)	0.9072	metric tons
British thermal units (Btu)	0.2520	kilocalories
Fahrenheit degrees	0.5556(°F - 32)	Celsius degrees



## ACKNOWLEDGMENTS

We are indebted to numerous people who assisted in the preparation of this profile. G. Van Dykhuizen wrote the first draft of the fish section, and T. Keating the first draft of the birds and mammals section. The investigators listed in Section 2 of References generously shared their unpublished observations with us. Complete, detailed reviews by C. Harrold and G. VanBlaricom were especially useful in revising the manuscript. All or parts of the entire profile were also read by N. Andrew, D.C. Barilotti, W.J. Ballantine, R. Brown, M. Carr, R. Cowen, P. Dayton, T. Dean, L. Deysher, A. DeVogelaere, A. Ebeling, J. Estes, Z. Hymanson, S. Kennelly, S. Kimura, E. Low, M. Neushul, A. Perry, D. Reed, L. Stocker, and J. Watanabe, and we thank them for their helpful suggestions. R. Stelow and C. King typed the manuscript, L. McMasters

drafted most of the drawings, and S. Dearn, M. Tomasi, and G. Van Dykhuizen helped compile the references. D. Schiel was partially supported by the Claude McCarthy Foundation of the University Grants Committee, New Zealand, by the University of Auckland, and by the U.S.N.Z. Cooperative Science Program.

Special thanks go to J. Cooper of the U.S. Fish and Wildlife Service for encouraging us to write the profile, and to W. Kitchens of the U.S. Fish and Wildlife Service for his support, suggestions, and patience.

Each of us particularly acknowledges the person who most influenced our early work and views on kelp forest ecology. To Michael Neushul (MSF) and Howard Choat (DRS), we extend our special thanks.



## CHAPTER 1

### INTRODUCTION

*I know few things more surprising than to see this plant growing and flourishing amidst those breakers of the western ocean, which no mass of rock, let it be ever so hard, can long resist.*  
Darwin (1860).

This profile is about large brown algae of the genus Macrocystis and organisms associated with them in subtidal habitats along the west coast of North America. Historical interest in giant kelp was stimulated by its wide geographic distribution, particularly in the southern hemisphere, and by the immense size of the plants. As early as the 1600's, European mariners used Macrocystis as a navigational aid: the presence of a floating canopy of attached plants indicated shallow reefs, while floating bundles of drift plants indicated that the coast was not far off (North 1971b).

The relatively easy harvesting of plants made them the basis of the potash industry in the United States during the First World War. At present, some 150,000 wet tons are harvested annually, mostly for the extraction of algin, a hydrocolloid (Frey 1971). The recreational and aesthetic value of these plants is also recognized now because of the association between them and many desirable food species of fish and shellfish. Mammals such as sea otters and harbor seals, as well as numerous birds, also commonly occur in these habitats. The disappearance of a large tract of Macrocystis off the Palos Verdes Peninsula (Los Angeles County) and from other areas of southern California in the 1950's brought an awareness that these stands may be ephemeral in nature and particularly disturbed by pollution associated with large centers of population. This spawned a series of

research programs to study life history features of giant kelp and its associated organisms. It became apparent that many factors were responsible for the variation in kelp abundance. Variation through time was assessed by estimates of the cover of the surface canopy of Macrocystis in several localities (North 1967, 1969).

Differences in coverage between surveys were ascribed to human perturbation such as sewage outfalls (Wilson 1982), to warm water (North 1971b), and to grazers such as sea urchins (Leighton 1971; see Foster et al. 1983 for review). It was also clear that the temporal and spatial variation in Macrocystis abundance was controlled not by a single factor but by numerous factors, some acting in concert.

It is our aim to describe the giant kelp forest environment and to discuss the sources of variability in the distribution and abundance of the organisms in it, especially Macrocystis (see Preface). Besides geographic and temporal differences in plant abundance, great spatial differences in distribution are also evident at any one locality. Even in areas where hard substratum is available, any particular alga is usually restricted to a relatively narrow range of depths (e.g., McLean 1962, Neushul 1967). This sort of distribution can be the result of the interactions of many abiotic factors such as light and temperature change with depth, and biological factors such as

competition for space with other species. Even within sites of similar depth at one locality, other factors such as amounts of sediment covering the substratum and the presence of grazers may differ on a small spatial scale, resulting in a small-scale variation in the presence and abundance of algae. Each of these factors may act on a different life history stage of a species. Because both biotic and abiotic factors may change over small distances, the pattern of algal distribution and abundance may change from locality to locality (see Chapter 3). Moreover, some of this pattern may result from stochastic processes, large scale phenomena (Dayton and Tegner 1984a), and historical events that are difficult to study.

We have generally taken a functional approach in discussing the organisms in Macrocystis communities, as floristic and faunistic species checklists may be found in other sources (see Chapters 3 and 4). We discuss many species and environmental factors, assessing their interactions with Macrocystis and, where possible, their influence on some phase or phases of the life cycle of Macrocystis. It is our intention to influence the direction of future field-based studies involving Macrocystis. Research to date has gone through qualitative and descriptive phases, with a relatively small amount of experimental work. We hope to see more carefully conceived sampling and experimental research featuring specific hypotheses with replication and proper controls. We synthesize the extant literature and technical reports with this in mind, and include accounts of work in progress in several California localities.

### 1.1. TAXONOMY, DEFINITIONS, AND DESCRIPTIONS

The taxonomy of Macrocystis has been argued since the genus was first named by C.A. Agardh (1820, 1839), and has been reviewed by Womersley (1954), Neushul (1971a), and Brostoff (1977). C.A. Agardh recognized six species, based on blade and float characteristics of what were probably drift specimens (Agardh 1839). Hooker (1847) decided that only one species existed, M. pyrifera. Howe (1914) was the first to use the now commonly accepted system of holdfast characteristics to

separate another species, M. integrifolia (Howe 1914, Setchell 1932, Womersley 1954). Womersley (1954) used holdfast characteristics to decide that a third species, M. angustifolia, existed in Australia and Africa. The holdfasts of these currently recognized species are illustrated in Figure 1A. Neushul (1971a) mapped the distribution of the three species in the northern hemisphere, with M. integrifolia occurring north from Monterey, California to Sitka, Alaska; M. angustifolia occurring in central California and perhaps southern California; while M. pyrifera was distributed in southern California. Brostoff (1977) concluded, based on detailed morphological comparisons and transplant experiments, that the California M. angustifolia described by Neushul (1971a) should be designated M. pyrifera var. californica, with M. pyrifera becoming M. pyrifera var. pyrifera. Abbott and Hollenberg (1976), however, recognize only two species of Macrocystis from California, M. pyrifera in the subtidal zone and M. integrifolia in the low intertidal-shallow subtidal zone. For the purposes of this profile, we will abide by the Abbott and Hollenberg (1976) classification; references to "giant kelp forests" mean subtidal M. pyrifera communities found on the west coast of North America.

A few other terms are used throughout this book, so it would be useful to define them here. Almost every paper concerning Macrocystis mentions the rapid growth rates of individual fronds. Early descriptions also noted the great sizes of plants. The name "giant kelp" has remained the common designation of the species of Macrocystis. Because of the great sizes of individual plants, their trunk-like appearance in the water column (see cover photo), and the surface canopies which can be extensive along coastlines, these areas of subtidal habitat have been called "forests" and we will use this term. A "stand" refers to any localized group of plants. "Community structure" is used as a general term that includes the species composition, abundance, and three-dimensional distribution of organisms in a kelp forest. "Community dynamics" refers to change in structure with time.

A. Holdfast morphology of *Macrocystis* spp.  
(redrawn from Neushul 1971a)

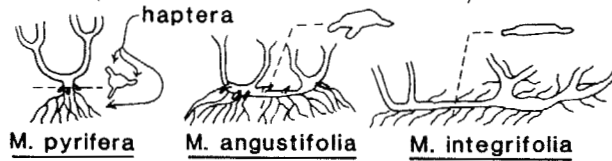

B. Morphology and life history of *M. pyrifera*  
(modified from Dawson and Foster 1982)

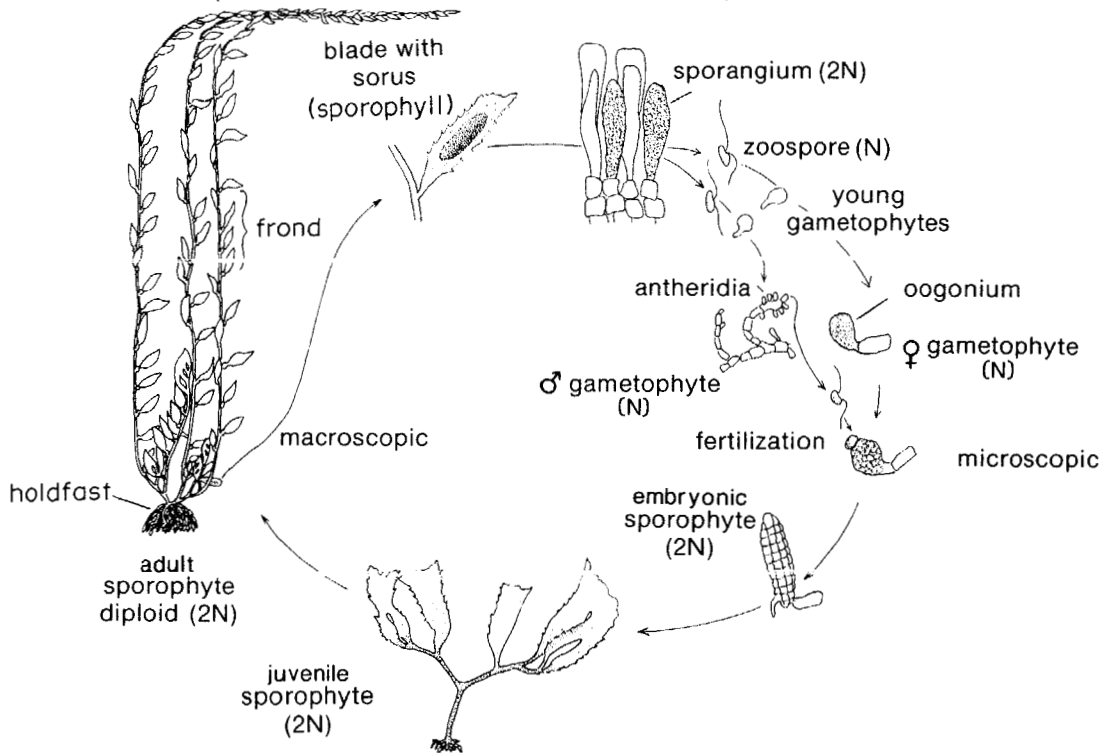

Figure 1. The morphology and life history of Macrocyctis.

Dense stands of Macrocyctis provide a vertically-structured habitat through the water column, and may have a considerable shading effect on the organisms below. These stands also provide nurseries, feeding grounds and/or protective cover for many other organisms. Darwin (1860) referred to them as great aquatic forests of the southern hemisphere, comparing them in complexity to terrestrial forests. Thus, giant kelp forests have come to mean the areas of coastline featuring extensive coverage by the surface canopy of Macrocyctis. Other kelps (using a re-

stricted definition of "kelp" as members of the Order Laminariales) that form surface canopies in temperate and polar regions may also form quite dense forests, but their tissue floating on the surface of the sea tends not to be as extensive as that of Macrocyctis (see Section 3.2.2). We will refer in general to communities with surface canopy kelps as "kelp forests," those with primarily Macrocyctis as "giant kelp forests," and those with other particular kelps as "bull kelp forests, etc." depending on the genus or species.

Kelps that produce surface canopies usually have floats (pneumatocysts) or other gas-filled structures for buoyancy. Numerous other kelps lack such structures and do not form a surface canopy except at low tide if they are growing in very shallow (1-2 m deep) water. They may, however, form dense canopies up to a few meters above the substratum to which they are attached. Extensive stands of these smaller laminariales occur in all temperate and some polar regions of the world. Conventionally, these stands are referred to as kelp "beds," recognizing subjectively that the vertical structure is not so extensive as it is for those species forming surface canopies. Communities featuring dense stands of *Laminaria* spp. have been studied in Nova Scotia (Mann 1972a, b, Breen and Mann 1976, Chapman 1981), and the British Isles (Kain 1979). In the southern hemisphere, *Ecklonia* spp. have been studied in New Zealand (Choat and Schiel 1982), Australia (Shepherd and Womersley 1970, 1971, Kennelly 1983), and South Africa (Velimirov et al. 1977). These beds are analogous to kelp forests but without a surface canopy, and the principles of sampling and experimenting in them should be no different than in giant kelp forests. We have drawn on this literature for comparisons with work in *Macrocystis* communities.

*Macrocystis* belongs to the Order Laminariales, Family Lessoniaceae. It has a typical laminarian life cycle (Figure 1B), with microscopic haploid spores (1N) developing into male and female gametophytes (1N). Eggs on female gametophytes are fertilized, and the zygotes develop into the macroscopic diploid sporophytes (2N). On mature plants, clusters of sporophylls containing reproductive tissue (sori) are found on the lower portion of plants just above the holdfasts (Figure 1b). Fronds (stipes with associated floats and blades) comprise the large portion of plants which are seen in the water column, and floating on the surface of the sea. Further descriptions of the life cycle and morphology of *Macrocystis* can be found in Abbott and Hollenberg (1976) and Lobban (1978).

## 1.2. DISTRIBUTION

Subtidal forests of *Macrocystis* occur in many areas of the world, but are most widely distributed in the southern hemisphere (Figure 2). Populations exist in the southern hemisphere along the east and west coast of South America, off South Africa, Tasmania and south Australia, New Zealand, and the sub-antarctic islands. As with other species with bipolar distributions, it is generally thought that temperature is the chief barrier to the geographic expansion into warmer waters (Hedgpeth 1957). However, recent work has shown an inverse relationship between temperature and nutrients, so low nutrients may be the important factor (see Sections 2.3 and 2.5). In contrast, Gaines and Lubchenco (1982) suggest that herbivory increases inversely with latitude, so extension into warmer waters may also be limited by grazing. A combination of cold water and low light levels acting on the various life history stages of plants probably prevents expansion of ranges toward the poles (Van den Hoek 1982). North (1982) suggested that the genus evolved in the southern hemisphere and its bipolar distribution in the Pacific (but not the Atlantic) may be the result of a cold water "bridge" in the geologic past (North 1971b). In contrast, Estes and Steinberg (MS.) point out that all but one of the presently recognized genera in the Order Laminariales occur in the North Pacific, and suggest a North Pacific origin and subsequent southern migration for these kelps, including *Macrocystis*.

Populations of *Macrocystis* in the North Pacific extend from Alaska to localities of upwelled cooler water in Baja California, Mexico (Druehl 1970; see Chapter 3). *Macrocystis pyrifera* is found from near Santa Cruz in central California to Baja California, Mexico (Druehl 1970). Abbott and Hollenberg (1976) give Alaska as the northern limit, but Druehl (1970) is probably correct as we have never observed the species much beyond Santa Cruz, and could find no other reports of a more northern distribution.

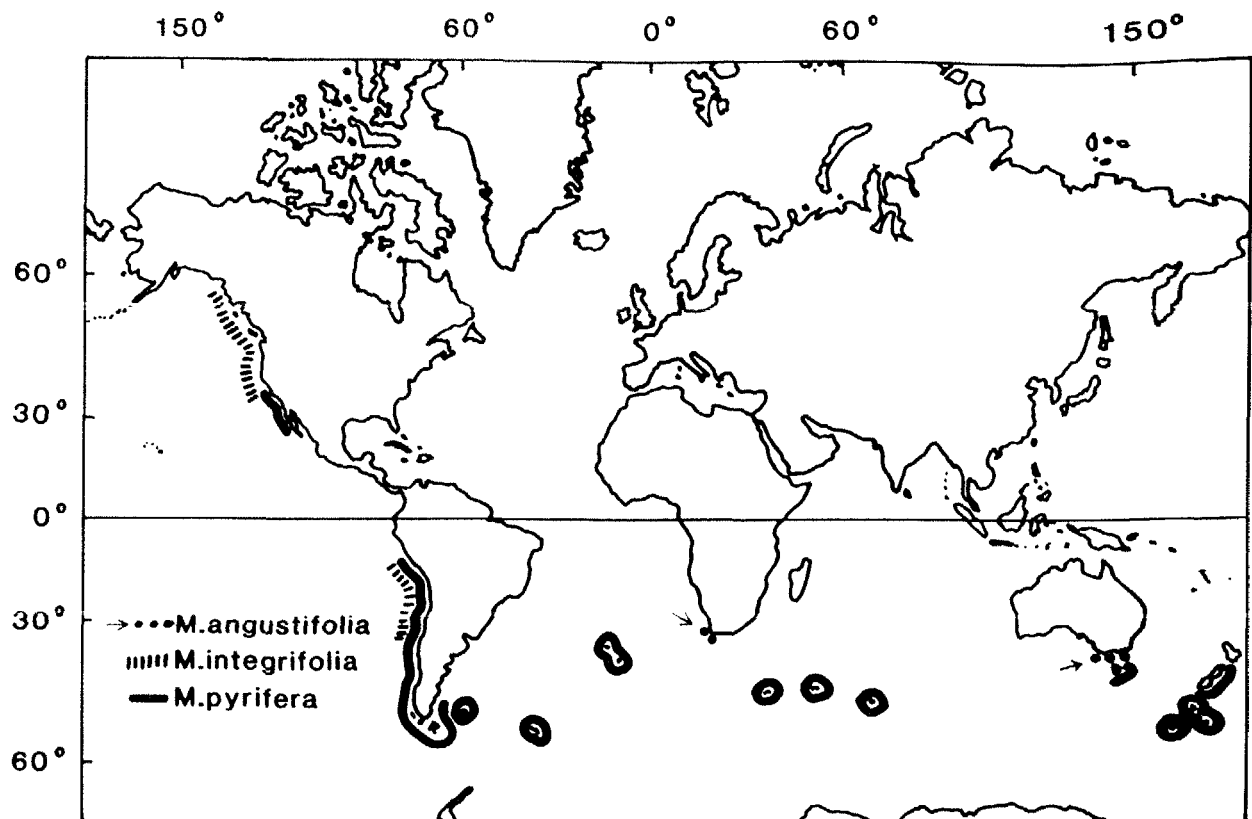

Figure 2. The geographic distribution of the species of Macrocystis (redrawn from Womersley 1954).

Besides geographic limits to distribution, there are also limitations within localities. Marine plants are depth restricted. Early surveys using SCUBA identified various zones similar to those in intertidal regions (McLean 1962, Neushul 1967, Aleem 1973; see Chapter 3). Stylized diagrams of depth distribution resulted in composite pictures, such as those in Figure 3. Surf grass (Phyllospadix spp.) is often found in very shallow subtidal areas, with another kelp, Egregia menziesii, also occupying the turbulent inshore sites. Several kelps may inhabit intermediate depths (4-15 m deep). Macrocystis pyrifera does not generally extend into very shallow water, or to depths below ~ 20 m in the turbid coastal waters. Figure 3 presents only a crude picture of depth distribution. It is interesting that there are no published studies which have quantified both the

abundances and depth distribution of conspicuous species of algae at different sites in California. Such a sampling program would result in a more solid framework for posing hypotheses about kelp forest dynamics, in much the same way that good experimental intertidal studies are based on detailed knowledge of the distributions and abundances of organisms (Dayton 1971, Connell 1972, Underwood et al. 1983).

### 1.3. KELP FOREST ECOLOGY

Distributional studies should be concerned with the numerical abundances of plants of a species in different locations. A single plant of a species such as Macrocystis may have a much larger impact on the rest of the community than a single understory kelp. Nevertheless, the presence or absence of a kelp forest is

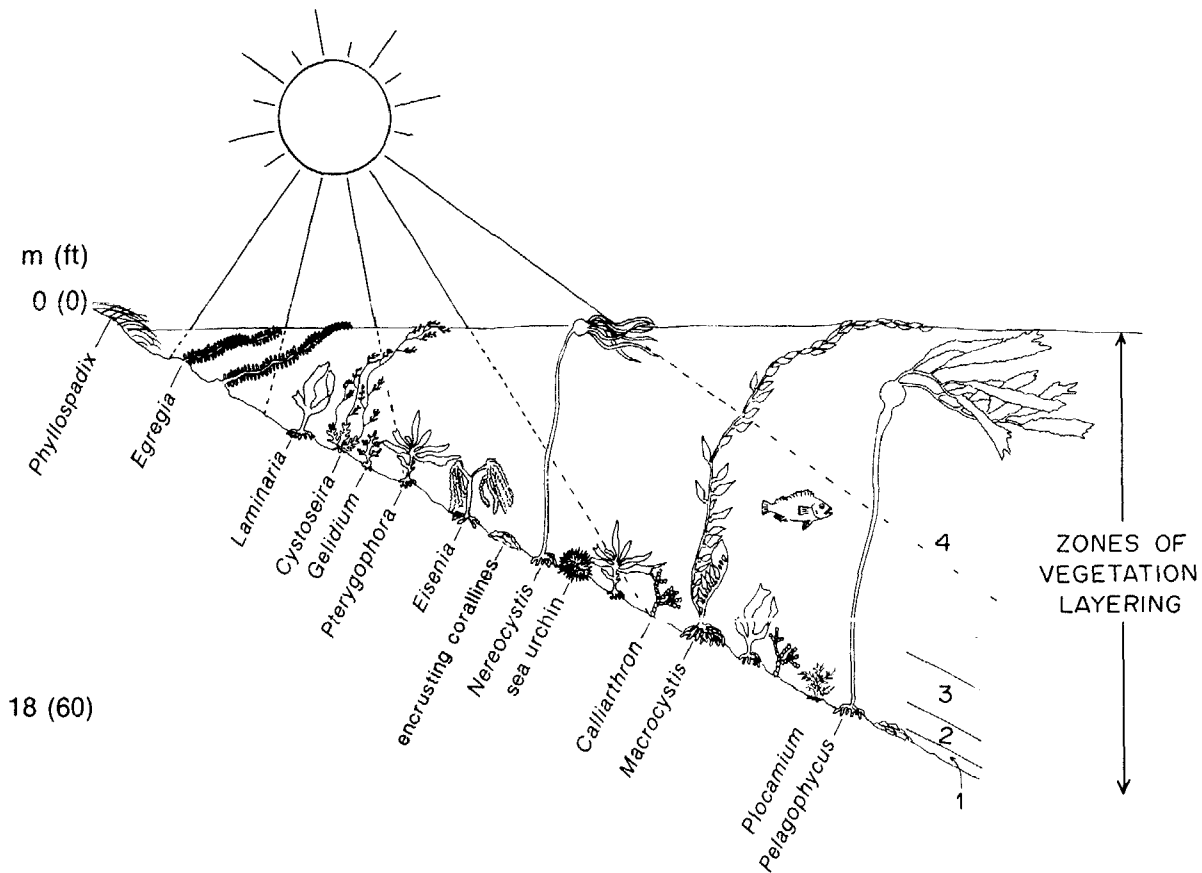

Figure 3. The distribution of some common seaweeds within giant kelp forests. Plants in the four zones of vegetation layering include (1) small filamentous species and encrusting coralline algae; (2) bottom canopy plants such as *Gelidium*, *Calliarthron*, and *Plocamium*; (3) understory canopy kelps such as *Pterygophora*, *Eisenia*, and *Laminaria*; and (4) midwater and surface canopy plants such as *Egregia*, *Macrocyctis*, and *Nereocystis*. This is a generalized diagram and some species do not co-occur in the same site (modified from Dawson and Foster 1982).

essentially the result of a "numbers game": How many plants are in an area? How fast do they grow? How long do they live? What is their reproductive output? How many new recruits appear? Plants also respond differently when placed in different conditions, such as those which occur naturally at different localities, and at different depths within the same localities. These sorts of demographic questions remain to be answered primarily by field-based studies.

This approach has generally not been followed in giant kelp forest research, and there is a definite bias in the

literature in studies done *in situ* with *Macrocyctis*. Most field research has been done at a very few sites (near Point Loma, San Diego County; the Palos Verdes area, Los Angeles County; and near Santa Barbara) to resolve questions about habitat loss and restoration. This is due to historic reasons, including the large population centers in southern California, kelp harvesting in the area, the presence of several universities with facilities for marine research, a sudden awareness of environmental problems coincident with the increase in sewer discharges, and the disappearance of large kelp forests on the Palos Verdes Peninsula and near Point



Loma. A succession of programs developed to study southern California kelp forest communities and to restore Macrocystis in areas where it was formerly abundant. The Institute of Marine Resources sponsored programs from 1956 to 1963; the Kelp Habitat Improvement Project investigated a number of problems from 1964 to 1976; and recently, the California Department of Fish and Game assumed responsibility for restoring coastal habitats (see Chapter 6). In addition, this work became particularly concerned with the interactions of sea urchins and kelp (North 1983a). Dense aggregations of sea urchins dislodged Macrocystis plants that subsequently drifted away (Leighton 1971). The major problem is that once plants have been removed by any cause, drift material declines, sea urchins apparently begin to forage actively for food, and this intensive grazing may prevent the re-establishment of kelp populations for some time (see Chapter 5). This has resulted in many programs to destroy sea urchins (Wilson and McPeak 1983).

The problems of controlling and managing what was seen as a resource eventually highlighted the need for work to assess the importance of other factors. In addition, recent work on giant kelp forests in central California (Pearse and Hines 1979, Cowen et al. 1982, Foster 1982a), South America (Barrales and Lobban 1975, Santelices and Ojeda 1984a, b), and southern California (Dean and Deysler 1983, Dayton et al. 1984) has begun to provide a broader perspective on the ecology of these communities. Table 1 presents a summary of factors which have been suggested or observed to affect the presence and abundance of kelp plants (see Chapters 2, 3, and 4 for details). The effects of most of these are not known, except in broad outline. The basic resources of space, light, and nutrients may be altered by differing biotic and abiotic conditions. Moreover, we have little idea of how different levels or combinations of these factors affect plant recruitment, growth, reproduction, and survival. These issues are discussed in detail in the following chapters.

Table 1. Factors influencing giant kelp forest algal populations with emphasis on Macrocystis pyrifera in California.

Factor	Influence
Substratum	Required for attachment Hardness related to mortality due to water motion Topographic heterogeneity correlated with distribution and diversity
Sedimentation and sand movement	Attachment and survivorship, especially of microscopic life stages Burial of all or portions of organisms Scour
Light: Amount Quality	Survival and growth of plants, at least 1% of surface for kelps Gametogenesis in kelps
Water motion	Plant and animal loss in surge and currents Distribution of food (plankton and detritus) Nutrient availability and uptake
Temperature	Growth and fertility of plants and animals
Nutrients	Growth of benthic plants (and phytoplankton)

(continued)

Table 1. Concluded.

Factor	Influence
Toxic substances:	
Cu	Reduced <u>Macrocystis</u> growth and reduced fertility at 30 ppb
DDT	Possible general alteration of community
Diseases of:	
Plants	Occur, but population effects?
Urchins	Can cause massive mortality
Sea stars	Occur, can cause massive mortality
Fish	Occur, but population effects?
Grazing by:	
Fish	Can destroy <u>Macrocystis</u> if plants at low density
Sea urchins	Can create areas of varied size nearly devoid of foliose macroalgae
Isopods	May destroy canopy and sub-canopy tissue
Other grazers	Consume small life history stages. Population effects?
Predation	Sea stars, sheephead, sea otters and other predators, including humans, may affect the distribution and abundance of a variety of species Sea stars and fishes may alter plant-sessile animal competition
Competition	Canopy shading inhibits understory algal recruitment and growth within and among species Pre-emption of space Whiplash effects of algal fronds Competition for space and light affects distribution of sessile species Competition (including behavior) affects fish distribution

## CHAPTER 2

### THE ABIOTIC ENVIRONMENT

*Environmental factors involved in seaweed ecology—light, nutrients, water motion, and temperature—have similar stratified distributions. As a result, it is difficult to determine which are the key factors. But it is easy to find a relationship of any one with algal distribution. Jackson (1977).*

#### 2.1. INTRODUCTION

The existence of a giant kelp forest depends upon physical and chemical conditions that favor the reproduction and growth of Macrocystis. With few exceptions, this abiotic environment includes a hard substratum, water temperatures generally  $< 20^{\circ}\text{C}$ , bottom light intensities equivalent to 1% of surface irradiance or greater, adequate nutrients, oceanic salinities, and protection from extreme water motion.

Much of the Pacific coast of California and Baja California, Mexico (Figure 2) fulfills these criteria. Nearshore waters to the north may be too exposed to water motion, while those to the south are probably too warm or low in nutrients (see Sections 2.3 and 2.5). The outer coast within the range of Macrocystis is moderately exposed to oceanic swells, salinity is relatively constant at around 33 ppt, and surface temperatures vary from a seasonal low of  $8^{\circ}\text{C}$  around Monterey to a seasonal high of around  $24^{\circ}\text{C}$  in Baja California (Section 2.3). In the southern part of this range, kelp forests are particularly well developed in cool, nutrient-rich upwelling areas. Plants commonly occur at depths between 5 and 20 m. The community may develop on almost any rocky bottom within these limits; the absence of Macrocystis commonly indicates an unstable bottom.

Macrocystis is usually not found in estuaries or very far inside protected bays. The reasons for its absence in such habitats have not been investigated, but are probably related to factors such as lack of rocky substrata, decreased light, increased sedimentation, and reduced salinity. North (1969) reported severe damage to adult giant kelp transplants in Newport Bay when salinity was lowered to 10 ppt during a storm. North (pers. comm.) has also found that cultured gametophytes do not survive at salinities below 25 ppt.

In the rest of this chapter we discuss the abiotic environment in detail for Macrocystis. The abiotic conditions necessary for other organisms are also described but, in most cases, very little information is available.

#### 2.2. SUBSTRATUM AND SEDIMENTATION

With few exceptions, the sessile organisms associated with giant kelp forests require a hard substratum for attachment. If these plants and animals do manage to attach and grow on sediment, they are usually swept away in all but very calm water. Extensive areas of cobble and boulder occur between Oceanside and Del Mar in southern California, and adult Macrocystis in this region commonly grow on these substrata, particularly in

the vicinity of San Onofre. If water motion is great enough, the drag on these and other kelps is sufficient to dislodge them and their substrata from the bottom. These plants plus cobble "anchors" may re-establish elsewhere if conditions are suitable, or be transported to the beach or to deeper water (SCE 1982).

In areas of extensive rocky reefs, the hardness of the substratum is also important; organisms growing on soft rock such as mudstone may be dislodged because drag on the plants, induced by water movement, fractures the rock. Differences in community composition in central California may partially result from differences in rock type (Foster 1982a).

The major exceptions to this occurrence on rocky substrata are kelp forests in the vicinity of Santa Barbara, where Macrocystis commonly grows attached to sediment (Thompson 1959, Neushul 1971a, North 1971b). Neushul (1971a) suggested that young plants first establish on solid surfaces such as worm tubes. As the plants grow, anchorage is increased by sediment partially covering, and accumulating in, the holdfast. These holdfasts can be over a meter in diameter, and Barilotti (pers. comm.) found that, once holdfasts are established, they become the primary site for subsequent new recruitment. The large size of the holdfasts probably results from the accumulation of haptera from successive generations of plants.

Sediment affects giant kelp forests in two other ways: large amounts of shifting sediment can scour or bury established populations in rocky areas (Weaver 1977), and relatively small amounts of sediment on, or falling on, the bottom can reduce the survivorship of microscopic life history stages. The former has been observed by North (1971b), who suggested that Macrocystis fronds are particularly susceptible to damage if buried, and by Foster et al. (1983), who indicated that changes in sediment cover may be responsible for some of the historical changes in the areal extent of kelp forests in the vicinity of San Onofre. Johnson (1980) recounts observations, made in the late 1800's on San Miguel Island (near Anacapa Island, see

Chapter 3), indicating that kelp forests were destroyed by sand eroded from the land. Grigg (1975) listed burial as an important cause of mortality in Muricea californica, a gorgonian coral commonly found on reefs and in kelp forests south of Point Conception. Burial can also kill young hydrocorals (Allopora californica) (Ostarello 1973) and other sessile animals (Weaver 1977), and may kill slow-moving invertebrates like the California cowry (SCE 1979). Sediments can clog the filter-feeding apparatus of many invertebrates, and may be partly responsible for the generally higher abundances of filter feeders such as Allopora on vertical surfaces where sedimentation is reduced (Ostarello 1973).

Scour can also be caused by the blades of understory algae rubbing over the bottom. Velimirov and Griffiths (1979) described bare areas between patches of Laminaria pallida produced by blades sweeping the bottom. The effects of this type of scour have not been examined within giant kelp forests.

A mosaic of sediment and rock patches is common in many kelp forests, and this pattern may change, particularly during storms. Small patches of shifting sediment are one disturbance that kills established organisms, creating new space for re-colonization. This disturbance may thus have important effects on composition and diversity within certain kelp forests (Rosenthal et al. 1974, Foster 1975a, Grigg 1975).

Laboratory experiments by Deviny and Volve (1978) showed that even very small amounts of sediment can greatly inhibit the attachment and growth of Macrocystis spores. This could have a significant effect on adult distribution in the field. Sedimentation rates, as measured with sediment tubes, are also negatively correlated with sporophyte recruitment (Dean et al. 1983). It is highly probable that the small stages of other algae and invertebrates (such as gorgonian corals; Grigg 1975) are also negatively affected in this way.

Macrocystis can grow while drifting, and early descriptions of the plant suggested it might exist in large unattached

floating masses as Sargassum does in the Sargasso Sea (see discussion by North 1971b). Although "seas" of Macrocystis have not been found, Moore (1943) and Gerard and Kirkman (1984) described large numbers of living plants with unusual branched fronds drifting on the bottom in quiet bays in southern New Zealand.

### 2.3. TEMPERATURE

Subtidal organisms are continually submerged, and thus are not exposed to the extremes of temperature found in the intertidal zone. However, considerable seasonal and year-to-year differences in temperature occur within the range of giant kelp forests. These differences have been suggested as important to plant distribution, especially on a geographic scale (North 1971b, Murray et al. 1980, Van den Hoek 1982).

Any discussion of temperature (and other abiotic factors) must be prefaced with warnings about factor covariance and interaction, relationships between temporal and spatial scales of measurement vs. plant response, and differences in response of different life history stages (see Wheeler and Neushul 1981 for review). The effects of temperature and other abiotic factors are often examined alone in field correlations and single-factor laboratory experiments. As pointed out by Hedgpeth and Gonor (1969), however, the effects of temperature can vary depending on other factors such as light and nutrients. These interactions have been suggested (Druehl 1978) or demonstrated as important for Macrocystis and other kelps (Luning and Neushul 1978, Dean et al. 1983). Moreover, the measurement of temperature in the field may not truly reflect what the organism actually experiences. For example, a shallow thermocline can occur within kelp forests, with bottom temperatures considerably colder than those at the surface. Thus, using surface temperatures as an indication of temperatures within a kelp forest can be inappropriate. The vast majority of seawater temperature measurements are made at the surface. In addition, depending on tides, thermocline position, etc., temperatures on the bottom at kelp forest depths can vary 4 °- 8 °C in less than a day (Quast 1971c, Barilotti and

Silverthorne 1972, Zimmerman and Kremer 1984). Rosenthal et al. (1974) found mean and maximum surface temperatures near their study area over a five-year period to be 16.3 °C and 24.6 °C, respectively, while the mean at 17 m was 13.0 °C, and the maximum 16.0 °C.

Monthly mean surface temperatures of nearshore waters within the western north Pacific distribution of large stands of Macrocystis pyrifera vary from 12 °- 15 °C near Santa Cruz, California to 18 °- 23 °C in Baja California, Mexico (Sverdrup et al. 1942). It is generally believed that adult giant kelp do not grow well above 20 °C, although plants have been found in an area of Baja California, Mexico, where temperatures exceeded this value for several weeks (North 1971b). This latter observation may be exceptional, as plants in Baja California, Mexico generally occur in areas where cool water is upwelled (Dawson 1951). Canopies and entire plants deteriorate in southern California during years when sea water temperatures are elevated ("El Nino" oceanographic conditions; see Section 2.5 below) suggesting that high temperatures (or associated low nutrients, see Section 2.5) have deleterious effects on adult plants.

Growth of gametophytes of a variety of kelp species in southern California is generally optimal at 17 °C, while fertility is optimal at 12 °C. Both of these processes were optimal at around 12 °C in gametophytes from central California (Luning and Neushul 1978). Bull kelp (Nereocystis luetkeana) does not occur south of Point Conception, and Vadas (1972) concluded that this is because gametophyte fertility and young sporophyte growth occurred at 15 °C but not at 20 °C. However, this conclusion about distribution is questionable, as temperature effects between 15 ° and 20 °C were not evaluated, and temperatures below 20 °C are common for many months of the year south of Point Conception (Barilotti and Silverthorne 1972, Mearns 1978, Dean et al. 1983). One might expect that, if temperature were of great importance to geographic distribution, plants from areas with different temperature characteristics would exhibit different responses to temperature. North (1972b) found that sporophytes transplanted from Baja

California, Mexico, to Newport Bay in southern California survived better during periods of warm water than native plants. Deysher and Dean (pers. comm.) are evaluating the growth and fertility of Macrocystis pyrifera gametophytes produced from adults collected in Baja California, Mexico (warm water), the San Diego area (moderate-warm water), and Monterey (cold water). In contrast to the findings of North (1972b), their preliminary results indicate all gametophytes behave similarly, and sporophyte production occurs at 20 °C if nutrients are adequate. Growth and fertility decline rapidly above 23 °C in all plants. More of these kinds of experiments, combined with adequate temperature records from geographic boundaries, are needed to evaluate temperature-distribution hypotheses critically.

Temperature has also been suggested as being important to the geographic distribution of kelp forest fishes and invertebrates (Quast 1971a, Gerrodette 1979). As for bull kelp and gorgonian corals (see above), major changes in the distribution of kelp forest species occur near Point Conception where the California Current moves offshore, creating large changes in temperature within a short distance. Briggs (1974) also emphasized the importance of these changes near Point Conception in his review of marine biogeography. However, most of the relationships between distribution and temperature are based on correlative evidence, and the difficulties mentioned above for algal distribution also apply to these other kelp forest organisms (see Gerrodette 1979).

#### 2.4. LIGHT

The methods of measuring light relative to the biology of kelp forest organisms have undergone numerous changes in recent years, and an understanding of these changes is necessary to interpret the results of light studies. Luning (1981) recently reviewed this subject, so we will only briefly summarize it here to aid the discussion that follows.

Marine plants have a diverse array of light-absorbing pigments such that wave-

lengths of between roughly 400 and 700 nm are used in photosynthesis (so-called PAR or Photosynthetically Active Radiation); other plant processes may be sensitive to light outside this range (Luning 1981). Inexpensive, portable instruments to measure light in this region of the spectrum were not available until recently, and most early measurements were made with photometers that measure light (illuminance) in foot-candles (English), or lux (metric; 1 f-c = 10.764 lux). Illuminance is based on the sensitivity of the human eye, and measurement instruments are designed with maximum sensitivity in the green region of the spectrum (550 nm). Therefore, photometers do not properly measure the light actually available for photosynthesis. Later measurements have been made with instruments that detect all portions of the spectrum with equal sensitivity in energy units (such as watts/m<sup>2</sup>; irradiance). With proper filters, these instruments can measure just PAR. Light quantity can also be measured as photon flux density. This is a particularly appropriate unit because photosynthesis is a quantum process. Instruments are now available which measure photon flux density of PAR. The units are Einsteins/area/time or mols/area/time, where 1 Einstein = 1 mol =  $6.02 \times 10^{23}$  photons. Unless otherwise noted, light measurements below are photon flux density of PAR.

Adequate light is essential for the growth of Macrocystis and other plants within a kelp forest, and may affect the behavior of other organisms such as fishes (Quast 1971c). Most seaweeds in a kelp forest at least start life on the bottom, and light, as well as other factors affecting plant growth, must be suitable there. In the absence of other possible controlling factors (presence of sand, grazers, etc.), the lower depth limit of giant kelp and, therefore, giant kelp forests, is probably determined by light. Luning (1981) suggested that for most kelps, this limit will occur where irradiance is reduced to ~ 1% of that at the water's surface. Giant kelp generally grows deeper in clearer water as seen in some central California kelp forests where depth distributions are correlated with water clarity (Foster 1982a). Barilotti (pers. comm.) notes that the outer

(deeper) margin of the Point Loma kelp forest has receded to depths shallower than at the turn of the century, and suggested that this may be due in part to increased turbidity associated with the nearby San Diego sewer outfall.

The quality or spectral distribution of light also changes with depth and water characteristics (Jerlov 1968, Luning 1981); this may affect the distribution of plants that require particular wavelengths of light to maintain growth. In addition, many kelps require a certain amount of blue light for the induction of fertility in gametophytes (Luning and Dring 1972, Luning and Neushul 1978, Luning 1980). For *Macrocystis* at 14 °C, a total of between 1.5-12.3 E/m<sup>2</sup> of wavelengths between 400 and 530 nm is required to induce 50% fertility (Luning and Neushul 1978, Deysher and Dean in press). The blue light response varies because it is affected by the rate at which this light is received; gametophytes have both thresholds and saturation points (Deysher and Dean in press). Work with other kelps suggests that the amount of blue light required also varies with temperature (Luning 1980). Growth occurs without blue light, but reproduction does not.

Luning's (1981) suggestion that 1% of surface irradiance is required for kelp growth is an over-simplification because light requirements differ for different stages of the same plant, and these stages occupy different depths and thus different light regimes. The depth where 1% light occurs can vary with water clarity and canopy development. Table 2 lists light requirements for growth in various stages of *Macrocystis*. The values given should be considered approximate as requirements may vary with geographic location, temperature, nutrients (Luning and Neushul 1978), water motion (Wheeler 1980b) and, for photosynthetic measurements on adult blades, position in the water column (Wheeler 1980a).

Growth will slow at light levels below saturation, and fertility will decline if less blue light is available. Dean et al. (1983) estimated that *Macrocystis* gametophytes outplanted on artificial substrata in the San Onofre kelp forest must receive the light

Table 2. Downwelling light levels (E/m<sup>2</sup>/day) for gametogenesis and compensation (growth) and saturation (highest growth rate) of growth in various stages of *Macrocystis*. For reference, 1% of surface light, suggested by Luning (1981) as the lower light limit for kelp growth, is about 0.2 E/m<sup>2</sup>/day.

Stage	Compensation	Saturation
Gametophytes		
Growth <sup>a</sup>	0.3	2
Gametogenesis <sup>b</sup>	0.2 - 0.4	0.4 - 0.8
Young sporophytes <sup>a</sup> (~ 1 cm long)	0.1	1.5
Juvenile sporophytes <sup>c</sup> (~ 0.2-1 m long)	0.6 - 0.7	2 - 3
Adults <sup>d</sup>	0.1	10

<sup>a</sup>From Dean et al. 1983.

<sup>b</sup>From Deysher and Dean (in press).

<sup>c</sup>From Dean and Jacobsen (in press).

<sup>d</sup>From photosynthetic rates in Clendenning 1971c. Light levels were converted from foot-candles using conversion of Luning 1981, and assuming a 12-h day with constant light.

necessary to become fertile within about 40 days. Beyond this time, mortality due to factors such as sedimentation and grazing is apparently so high that few gametophytes survive. This life history stage can live and grow for much longer periods in the laboratory (Sanbonsuga and Neushul 1980), but whether gametophytes can live longer on natural substrata in the field is unknown. Larger stages may survive longer at suboptimal light levels because they are partly above the bottom and not as affected by these factors.

Adult *Macrocystis* plants are generally insensitive to changes in subsurface light because they usually form a surface canopy, and can translocate the products of photosynthesis toward the holdfast (Parker 1963, Lobban 1978). Younger stages are located on or near the bottom, however, so a kelp forest could

disappear even if light was favorable for adult growth. Light transmission to the bottom is affected by the amount of surface light, the water, dissolved and suspended material in the water, and shading by attached organisms. Surface light intensity varies with latitude, season, and cloud and fog cover, but the range of intensities is much less than that created by water characteristics (Dean MS.). Day length may be important in triggering photoperiodic reactions, but this has not been investigated in subtidal plants (Luning 1981).

Light is attenuated logarithmically with depth, and each wavelength has a particular extinction coefficient (Jerlov 1968). The extinction coefficient also varies with turbidity; in clear water, blue light is transmitted further than green light, while in more turbid coastal water, the reverse occurs (Jerlov 1968). Overall light transmission declines with increasing turbidity and, within the coastal water types designated by Jerlov (1968), Luning (1981) estimated that the depth where irradiance is reduced to 1% of surface varies between 3 and 30 m.

Water clarity or turbidity is influenced by terrestrial runoff, sediments resuspended by wave surge (Quast 1971c), plankton abundance (Quast 1971c, Clendenning 1971b), and probably dissolved and particulate matter produced by kelp forest organisms (Clendenning 1971b). We have observed the first three of these to produce near darkness on the bottom in kelp forests at mid-day. Moreover, changes in water masses with changing current conditions can cause rapid (less than an hour) changes in water clarity. For these reasons, short-term measurements of light on the bottom, although useful in comparing nearby areas at the same time, should be used with caution in characterizing the light regime of a site. Light regimes, particularly if they are to be used for correlations with algal recruitment and growth, should be determined with in situ continuous recorders (Luning 1981; see Ramus in press, and Foster et al. in press for methods).

Some of the earliest observations in kelp beds and forests suggested that the plants themselves have a great effect on light reaching the bottom (e.g., Kitching et al. 1934). Macrocystis canopies can reduce irradiance by over 90% (Neushul 1971b, Dean et al. 1983, Reed and Foster 1984, Santelices and Ojeda 1984a), and dense surface canopies of giant kelp are often associated with a relatively sparse understory algal flora (Dawson et al. 1960, Neushul 1965, Foster 1975b). Within a locality, understory algal cover (Foster 1982a) and Macrocystis recruitment (Rosenthal et al. 1974, Reed and Foster 1984) can vary inversely with Macrocystis canopy cover. Pearse and Hines (1979), Reed and Foster (1984), and Dayton et al. (1984), using experimental plant and canopy removals, have demonstrated that giant kelp canopies can inhibit the recruitment and growth of the algae beneath them. Moreover, natural kelp recruitment usually coincides with times when the surface canopy is reduced (Rosenthal et al. 1974, Kimura and Foster in press). Santelices and Ojeda (1984b) also report an increase in Macrocystis pyrifera recruitment when the surface canopy was experimentally removed. In contrast to some of the above studies, however, understory kelp biomass decreased.

Understory kelps such as Pterygophora californica, Eisenia arborea, and Laminaria spp. cause further light reductions, and the flora beneath stands of P. californica is often reduced to articulated and encrusting corallines (Reed and Foster 1984). At a constant depth of 15 m, Reed and Foster (1984) measured photon flux densities of 2%-6% of surface in open water, 0.2%-2.5% under canopies of either Macrocystis or Pterygophora, and < 2% (usually < 0.5%) under their combined canopies. Experimental removal of understory kelp canopies can result in increased recruitment and growth of plants, including Macrocystis (Kastendiek 1982, Reed and Foster 1984, Santelices and Ojeda 1984b, Dayton et al. 1984). Bottom-cover plants such as articulated corallines also inhibit recruitment, at least in part by further reducing light (Reed and Foster 1984).



## 2.5. NUTRIENTS

Most plants, including seaweeds, are photoautotrophic; the sun provides energy, but the plants require a variety of inorganic and some organic nutrients, such as vitamins, to manufacture the chemicals necessary for growth and reproduction. Subtidal seaweeds must obtain all their nutrients from the water because holdfasts are attached to solid substrata (no soil) and appear to serve no special nutrient uptake functions. Moreover, except for the occasional frond in the surface canopy, tissues are not exposed to air, and thus all metabolic processes occur in water.

Few macroalgae have been grown in defined culture media in axenic conditions, so we know little about their complete nutrient requirements (DeBoer 1981). The assumption is that their inorganic requirements are similar to terrestrial plants (14-21 elements in various forms; DeBoer 1981). North (1980) identified 38 elements in *Macrocystis* tissue, and Kuwabara and North (1980), using microscopic stages of *M. pyrifera* cultured in defined media, found that at least nine elements were essential for growth and reproduction. These, along with carbon and oxygen, are listed in Table 3. DeBoer (1981) suggested that of these, nitrogen, phosphorus, iron, and perhaps manganese and zinc, may possibly limit growth of macroalgae in nature, and North (1980) concluded that copper could also be limiting for *Macrocystis*.

Of the possible nutrients that could limit kelp forest algal growth in the field, nitrogen has received the greatest attention, particularly as it may affect *Macrocystis* growth in southern California (Jackson 1977, Wheeler and North 1981, Gerard 1982a, b, c, Zimmerman and Kremer 1984). Gerard (1982a) indicated that inorganic nitrogen concentrations in the surrounding water must be in the order of 1-2  $\mu\text{M}$  ( $1\mu\text{M} = 1\mu\text{g-atom/liter}$ ) to support a typical giant kelp growth rate of 4% increase in wet weight per day. Inorganic nitrogen concentrations vary widely in nearshore waters, but are particularly high during upwelling or when there is terrestrial runoff (North et al. 1982). They are low ( $< 1\mu\text{M}$ ) in summer and fall in

Table 3. Known nutrient requirements for *Macrocystis pyrifera*.

Elements <sup>a</sup>	Form Normally Used by Plants <sup>b</sup>	Limiting in Nature <sup>c</sup>
Carbon (C)	$\text{HCO}_3^-$ , $\text{CO}_3^{=}$	No
Oxygen (O)	$\text{O}_2$	No
Nitrogen (N)	$\text{NO}_3^-$ , $\text{NH}_4^+$	Sometimes
Phosphorus (P)	$\text{PO}_4^{-3}$	Maybe
Manganese (Mn)	--	Maybe <sup>d</sup>
Iron (Fe)	Probably colloidal	Maybe
Cobalt (Co)	--	No <sup>d</sup>
Copper (Cu)	--	Maybe <sup>e</sup>
Zinc (Zn)	--	Maybe <sup>e</sup>
Molybdenum (Mo)	--	No
Iodine (I)	--	No

<sup>a</sup>From Kuwabara and North 1980.

<sup>b</sup>Where forms are not given (--), it is assumed that the element is used as a free ion.

<sup>c</sup>From DeBoer 1981.

<sup>d</sup>May limit *Macrocystis* growth in deep oceanic water (Kuwabara 1982).

<sup>e</sup>Toxic to *Macrocystis* as free ions in deep oceanic sea water (Kuwabara 1982).

southern California (especially above the thermocline if the water is thermally stratified), and during periods when warm water masses move into the region from the south (Jackson 1977, Wheeler and North 1981, North et al. 1982). At Catalina Island in southern California, daily variation in nitrate concentration is frequently as great or greater than mean seasonal variations, and at least a one day per month intensive sampling is needed to characterize nitrate at this site (Zimmerman and Kremer 1984). Fewer measurements of inorganic nitrogen have

been made in central California, but those available indicate levels are generally above 1  $\mu\text{m}$  in these colder waters with frequent upwelling (Gerard 1976, Broenkow and Smethie 1978).

In southern California, giant kelp canopies commonly deteriorate during summer when inorganic nitrogen is low. Reduced nitrogen concentrations may have been responsible for the massive loss of Macrocystis during the warm-water period of the late 1950's (North 1971b, Jackson 1977, North et al. 1982), and plants deteriorated at many locations during the recent (1982-84) "El Nino" (Dean pers. comm., Dayton and Tegner 1984b). We observed late-summer canopy deterioration that may have been due to nutrient limitation at two locations in central California during 1979 and 1982. However, temperature and inorganic nitrogen concentrations are inversely correlated (Jackson 1977), so determining whether inorganic nitrogen or temperature (or a combination of both) is responsible for these phenomena is impossible from correlations alone.

Evidence that low inorganic nitrogen, not temperature, is limiting under low-nutrient/high-temperature conditions comes from fertilization experiments. Dean and Deysher (1983) found that more sporophytes were produced on fertilized artificial substrata inoculated with giant kelp spores and placed within a kelp forest than on similarly treated but unfertilized controls. Zimmerman (pers. comm.) examined the cause of the summer decline in adult Macrocystis growth at Big Fisherman Cove at Santa Catalina Island. Summer growth was increased when adult plants were fertilized with  $\text{NaNO}_3$ . However, growth was not as great in this experiment as the highest natural growth rates at other times of the year, suggesting that in summer, other nutrients and/or temperature may be limiting once the nitrogen requirements of the plants are met. Laboratory studies by Manley and North (1984) suggest phosphorous may be particularly important. North (1983b) added nitrate and phosphate to ambient temperature (18 °- 23 °C) water flowing into a large tank containing adult Macrocystis. These plants maintained healthy canopies and had high tissue

nitrogen levels, while nearby plants in the natural kelp forest, exposed to similar temperatures but not fertilized, suffered canopy losses and had low tissue nitrogen.

In addition to temperature (and perhaps other nutrients), physiological processes within giant kelp can further obscure the relationship between nitrogen in the water and plant growth. Seaweeds can store nitrogen when the concentration in the surrounding water is high (luxury consumption), and then use these reserves for growth when the surrounding concentration drops (Chapman and Craigie 1977). Macrocystis can accumulate non-structural nitrogen compounds (Wheeler and North 1981, Gerard 1982b) including nitrate (Druehl pers. comm.), and then use these reserves to maintain growth for at least two weeks in low nitrogen environments (Gerard 1982b). Thus, both the frequency of environmental sampling for inorganic nitrogen and the presence of tissue reserves can affect the interpretation of growth rate vs. inorganic nitrogen data.

The utilization of inorganic nitrogen in the water is also affected by water motion (Gerard 1982c, Wheeler 1982). Increased water flow over plants enhances uptake by increasing nutrient transport through the diffusion boundary layer (Neushul 1972, Gerard 1982c). Gerard (1982c) and Wheeler (1982) found that nitrogen uptake by Macrocystis increased with increasing current speed, up to a maximum at  $\sim 2-4$  cm/sec. Current velocities in kelp forests are often lower than this (Wheeler 1980b). However, Gerard (1982c) has shown that water flow caused by wave surge can be equivalent to that of the current speeds above, and pointed out that because the plants are attached to the bottom and each blade is attached to a fixed point on the plant, very small waves can produce flag-like blade movement. This motion, plus small currents and surge, are sufficient to saturate nitrogen uptake even under very calm conditions.

Little information is available on possible nutrient limitations in other kelps in giant kelp forests. Work in eastern Canada (Chapman and Craigie 1977, Gagne et al. 1982) and the Arctic (Chapman

and Lindley 1980) indicated that seasonal and site differences in kelp (*Laminaria* spp.) growth in these regions are related to the availability of inorganic nitrogen. The only other giant kelp forest plant so far investigated that may be nutrient-limited in the field is *Gelidium robustum* (formerly *G. cartilagineum*), an agar-producing red alga (see Chapter 4). Tseng and Sweeney (1946) determined that this plant uses dissolved  $\text{CO}_2$  rather than  $\text{HCO}_3^-$  or  $\text{CO}_3^{2-}$ . The plant is most abundant at wave-exposed sites in shallow water (< 12 m) where dissolved  $\text{CO}_2$  is more common. This suggests that carbon availability may limit the distribution both within (with depth) and between (exposed vs. sheltered) sites. Barilotti (1980) indicated that light and grazing may also affect *G. robustum* distribution.

## 2.6. WATER MOTION

Currents and surge produced by wind, tides, or waves have numerous direct and indirect effects on kelp forest communities. Currents are unidirectional flows (but the direction can change within hours), while surge moves back and forth over the bottom, as well as up and down above the bottom (Figure 4). Current speeds in kelp forests are highly variable, but in the range of near 0 to 15 cm/sec in the few kelp forests studied (Wheeler 1980b, Bray 1981, Jackson 1983). Neushul et al. (1967) measured speeds of 40 cm/sec near Anacapa Island. The drag at higher speeds can pull *Macrocystis* over at angles up to 30 degrees from vertical, and the entire surface canopy may submerge as a result (Neushul et al. 1967). This canopy submergence, along with that caused by changes in tide, can alter canopy extent as estimated with aerial photographs. As a result of plant drag, current speeds within kelp forests are often two to three times lower than the surrounding water (Jackson and Winant 1983), and if the forest is small, the incoming current will diverge around it, producing a "bow wake" similar to that of a ship (Jackson 1983). The reduction of surface waves by kelp plants is commonly observed as "quiet water" inshore from kelp forests (Darwin 1860), and artificial, kelp-like tethered floats have been used as breakwaters to reduce water movement in harbors (Isaacs 1976).

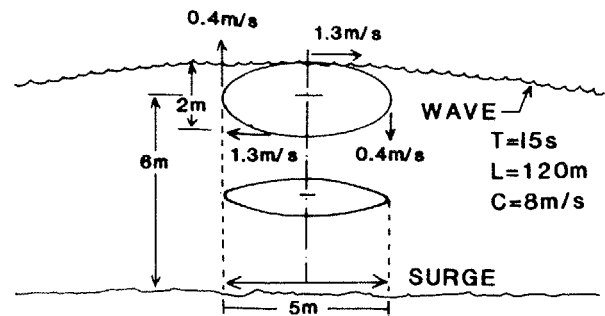

Figure 4. Water motion produced by swells in shallow water. Note that the orbital motion of water particles flattens toward the bottom, eventually becoming entirely horizontal to produce surge. In the example shown, a 5-m excursion of water was measured on the bottom at a depth of 6 m, when a 2-m wave moved past at a velocity (C) of 8 m/sec, a wave length (L) of 120 m, and a wave period (T) of 15 sec. Orbital velocities at the surface are also shown (re-drawn from Neushul 1972).

Even at high speeds, currents have not been observed to cause mortality of adult kelp forest organisms. They do, however, indirectly affect nutrient uptake by plants (see 2.5 above), larval and spore dispersal within and between kelp forests, and the distribution of particles that may serve as food for benthic animals (Pequegnat 1964) and fish (Bray 1981).

Surge speeds can be much higher than currents, particularly surge generated by long period swells associated with winter or tropical storms. In central California, 4-m high swells are typical in winter and produce water speeds of over 1 m/sec on the bottom at kelp forest depths (10 m). The force generated by water moving this fast is equivalent to the force produced by a wind speed of 126 mph (56 m/sec; Charters et al. 1969). As noted above (Section 2.2), such forces can pull benthic organisms off the bottom and fracture the bottom in the process. Storm-associated surge is perhaps the most important source of mortality for adult *Macrocystis* in California (ZoBell 1971, Rosenthal et al. 1974, Gerard 1976, Foster 1982a, Reed and Foster 1984, Dayton et al. 1984) and at sites studied in Argentina (Barrales and Lobban 1975). Plants are

often torn loose in patches during storms when one loose individual entangles with others still attached. This increases the drag on the holdfasts of the attached plants, contributing to additional detachment (Rosenthal et al. 1974). If the substratum is very hard and holdfasts firmly attached, surge may remove only long fronds, leaving the holdfast and small fronds that may grow vegetatively (Foster 1982a).

Differences in swell exposure probably account for many of the differences in canopy and plant density fluctuations between southern and central California. The east-west trend in the coastline, protection provided by offshore islands, and the distance from the northerly source of most winter storms all combine to make many southern California kelp forests relatively protected from large swells. Surface canopies in this region typically vary in extent in a three- to four-year cycle (North 1971b, Rosenthal et al. 1974), probably related to an increased susceptibility of older and larger plants with deteriorating holdfasts to removal by water motion. Canopies around Santa Barbara are even less variable, with occasional catastrophic losses due to atypically large swells (Fheling et al. MS.) or warm water (low nutrient) periods (North 1971b). There are exceptions, however; large swells in winter 1982-83 removed nearly 70% of the adult Macrocystis at some sites in the Point Loma kelp forest near San Diego (Dayton and Tegner 1984b), and over 90% of the Macrocystis surface canopy along the Palos Verdes Peninsula, Los Angeles (Wilson and Togstad 1983).

In contrast, most canopies in central California undergo a regular seasonal change with growth in spring and summer leading to maximum development in early fall, and then frond and plant loss during late fall and winter storms (Miller and Geibel 1973, Cowen et al. 1982, Foster 1982a, Kimura and Foster in press). In addition to these seasonal changes, there are year-to-year differences correlated with the severity of winter swells (Foster 1982a). This was especially evident in winter 1982-83, when swells over 7 m high with a 21-sec period were recorded in central California (Seymour 1983). Large

swells along the entire California coast during this period removed almost all Macrocystis surface canopies (McPeak pers. comm.).

If swells are too extreme, Macrocystis may not be able to persist in a given area. In the absence of biotic factors such as competition (Santelices and Ojeda 1984b), swells may determine the shoreward depth limit of kelp forests (North 1971b) because, for a given set of swell characteristics, surge speed increases as depth decreases. On a geographic scale, increasing surge may be the primary reason why M. pyrifera does not occur in large stands north of Ano Nuevo Island (near Santa Cruz) in central California. Nereocystis luetkeana is extremely resistant to breakage from water drag (Koehl and Wainwright 1977), and is the common canopy-forming kelp from Ano Nuevo Island north into Alaska. This change in surface canopy species may also be related to differences in life history characteristics, growth rates, and susceptibility to grazing (see Chapters 3 and 4).

Understory kelps seem generally more resistant to removal by surge (Reed and Foster 1984, Dayton et al. 1984), but these kelps, along with foliose algae that cover the bottom, may also be directly removed by surge, particularly if the substratum is soft rock (Foster 1982a).

Swells can also alter fish distribution (Quast 1971c), and can remove attached or mobile benthic invertebrates, especially those that project into the water above the bottom. Hines (1982) suggested that winter swells may be an important source of mortality in kelp forest spider crab populations. Cowen et al. (1982) found that sea urchin (Stongylocentrotus franciscanus) behavior was modified during winter when storms apparently caused animals to clump in cracks and depressions, and Agegian et al. (in prep.) suggest that mortality caused by surge at some sites in central California may restrict S. franciscanus distribution to deeper water or to areas protected from high water motion in shallow water. The white urchin, Lytechinus anamesus, moves less, covers itself with debris, and even burrows into

shell debris during periods of surge (Lees and Carter 1972). Activity of the sea urchin *Centrostephanus coronatus* is also reduced in turbulent conditions, and Lissner (1980) suggested that this urchin may also be excluded from areas by high water motion. Because sea urchin grazing can significantly alter the distribution of other kelp forest organisms (see Chapter 3), the effects of water motion on sea urchin distribution and activity can have significant indirect effects on community structure.

In addition to affecting distribution and behavior, water motion may alter the orientation of sessile organisms. The plane of the primary dichotomy of *Macrocystis* (Neushul et al. 1967), the branches of gorgonians, and the understory kelp *Eisenia arborea* (Foster pers. obs.) are commonly oriented perpendicular to the most common swell direction, presumably an adaptation to reduce mortality due to water motion and/or to increase capture of nutrients or planktonic food. Other characteristics of seaweed morphology related to water motion are discussed by Neushul (1972).

Water motion has numerous indirect effects on kelp forests, and some of these, such as nutrient uptake and changes in turbidity, scour, and sedimentation, are discussed with other abiotic factors. Of particular importance are effects on light caused by removal of overstory canopies during storms. In exposed kelp forests in central California, increased light resulting from the removal of *Macrocystis* canopies by storms is correlated with a three-fold or more increase in the cover of understory plants (Foster 1982a). Moreover, if understory kelps are sparse, giant kelp removal can affect kelp recruitment as well (Rosenthal et al. 1974, Pearse and Hines 1979, Reed and Foster 1984). Many of the direct and indirect effects of water motion are illustrated in the community regulation models shown in Figure 5. These models illustrate that the relative importance of particular factors can vary among kelp

forests, that factors are often correlated, and how they can interact to affect the species composition and distribution of organisms.

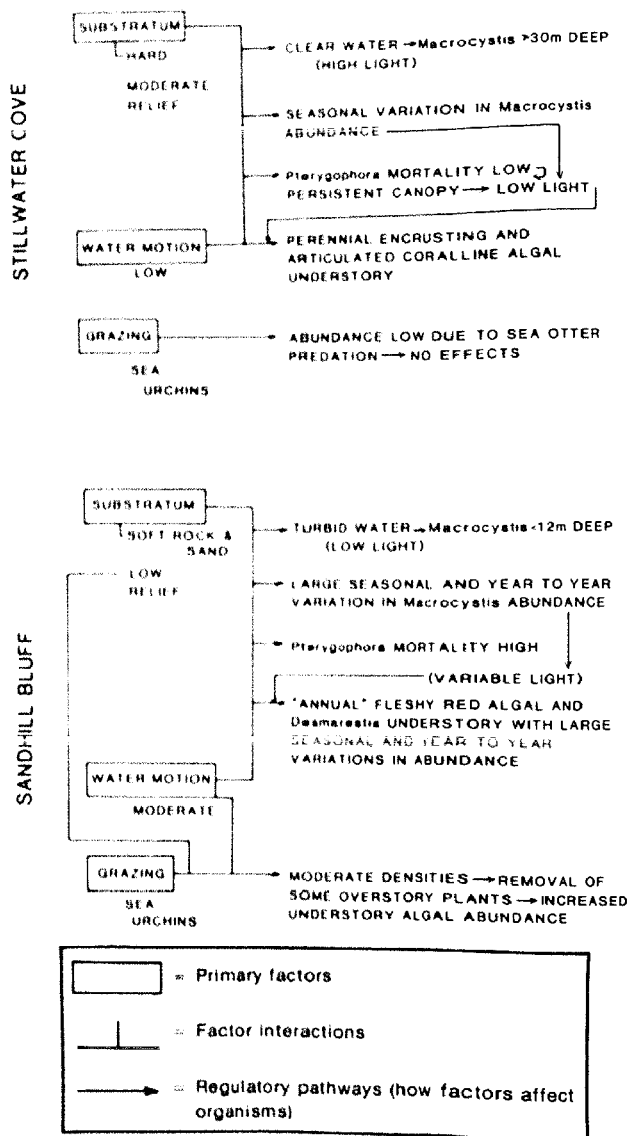

Figure 5. Factors, factor interactions, and regulatory pathways affecting the algal associations in two giant kelp forests in central California (see Chapter 3; from Foster 1982a).

## CHAPTER 3

### THE GIANT KELP COMMUNITY

*The biotic components and temporal population changes recorded off Del Mar should not be interpreted as "characteristic" of all southern California kelp beds. Rosenthal et al. (1974).*

#### 3.1 INTRODUCTION

We have defined giant kelp forests as subtidal communities composed of Macrocystis pyrifera and associated organisms. Although by definition, Macrocystis is always present in these communities, its local distribution and abundance vary in time and space, as do the distribution and abundance of other plants and animals associated with it (Clarke and Neushul 1967, Rosenthal et al. 1974, Foster 1982a). In addition, within the geographic range of Macrocystis forests, the species composition of associated organisms can also vary; their geographic ranges are not necessarily the same as for Macrocystis. So far as is known, no organisms found in stands of giant kelp have an obligate association with Macrocystis; they can be found in other kelp communities and on subtidal rocky reefs devoid of large brown algae (Pequegnat 1964, see Chapter 4). In this chapter we describe the community structure of a number of sites, discuss the spatial and temporal variability of this structure, and review kelp forest energetics.

To aid the discussion that follows, Figure 6 illustrates a "composite" giant kelp community with emphasis on the large, visually obvious kelps that provide much of the structure of the community, and for which we have the most descriptive information. The figure divides the community into habitats within giant kelp

forests where particular organisms typically co-occur. It is a composite, both because of local variation in species distribution, and because the geographic ranges of some of the organisms, such as sea otters (Enhydra lutris) and the elk kelp (Pelagophycus porra), do not presently overlap. The figure does, however, indicate the potential complexity of the community, with multiple layers of vegetation (Dawson et al. 1960, Foster 1975a), over 50 species of fishes that commonly segregate into various microhabitats (Quast 1971a, Miller and Geibel 1973, Feder et al. 1974, Ebeling et al. 1980a), and numerous invertebrates also found in particular habitats (e.g., on plants, on vertical or horizontal surfaces, and on holdfasts). North (1971b) listed 130 species of plants and almost 800 species of animals associated with giant kelp in southern California and northern Baja California, Mexico. The giant kelp holdfast alone may contain over 150 species (Ghelardi 1971). A variety of birds and mammals forage in the community, including cormorants, harbor seals, and sea otters. Kelp forests also contain a planktonic assemblage of generally microscopic organisms, many of which are stages in the life histories of larger members of the community.

As indicated in Figures 3, 6, 9, and 10, Macrocystis communities generally occur within a narrow depth range. Even if suitable substrata are available, M. pyrifera usually does not occur shallower

than ~ 5 m, and deeper than about 20 m. Depending on location, other kelps may form relatively sparse surface canopies in shallower or deeper water. These areas outside the range of Macrocystis are also

included in the discussion below, as organisms within a kelp forest may have ranges that extend both shallower and deeper than Macrocystis.

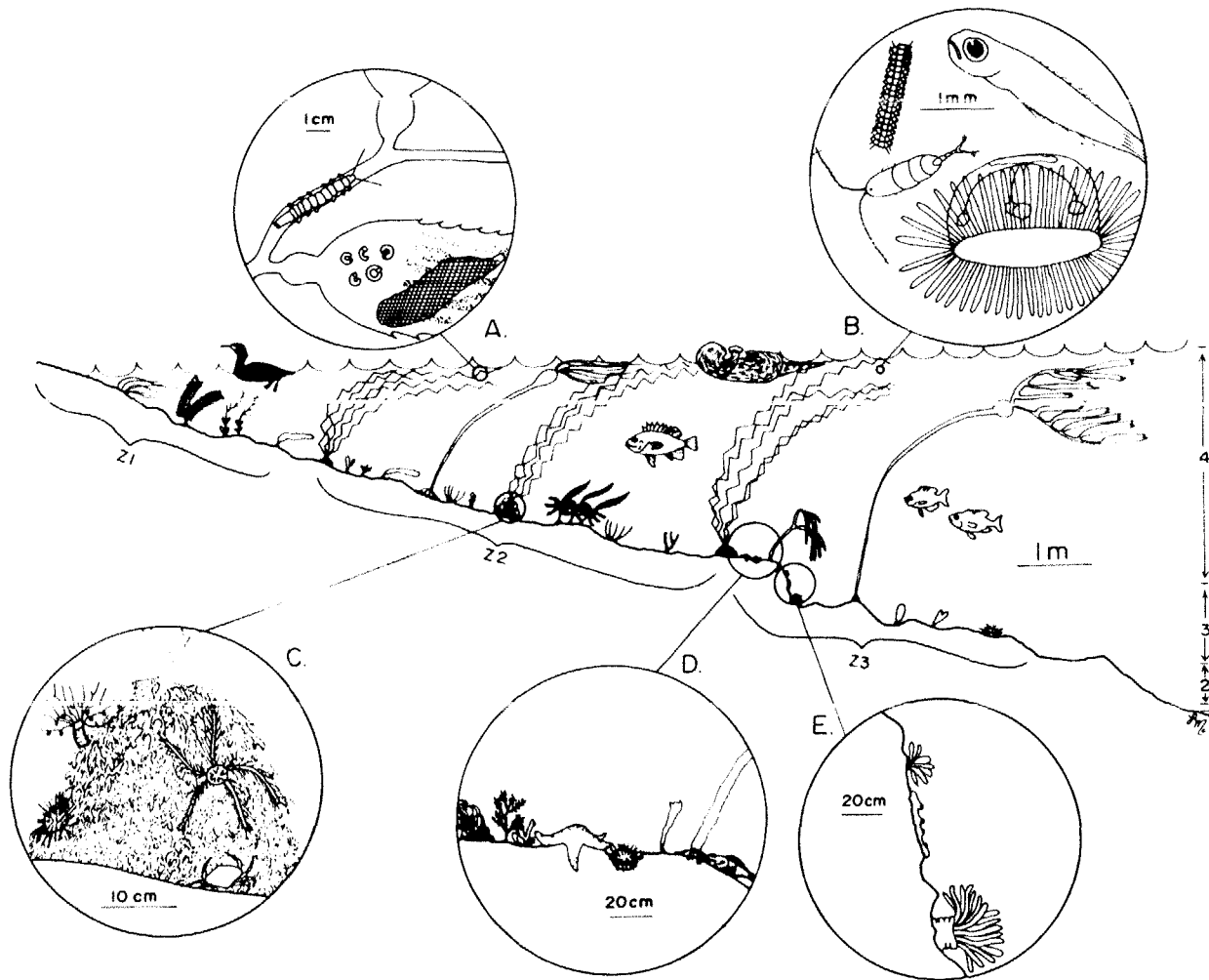

Figure 6. Cross-section showing the inhabitants of a generalized giant kelp forest. The numbers to the right indicate vegetation layers (see legend for Figure 3). Three broad zonal associations along the depth gradient are shown: Z1, inshore of the giant kelp community; Z2, within the giant kelp community; and Z3, offshore from the giant kelp community. Various subcommunities or associations are indicated by the circular diagrams: A, animals associated with the surface of Macrocystis and other seaweeds (polychaetes, isopods, bryozoans); B, plankton in the water (various phytoplankton, zooplankton and larval fish); C, animals found in giant kelp holdfasts (small sea urchins, brittle stars, crustaceans, polychaetes; although shown on the outside, these organisms occupy the spaces between the haptera); D, plants and animals characteristic of horizontal surfaces (various sea stars, urchins, benthic fishes, understory algae); E, organisms most common on vertical surfaces (primarily sessile animals such as sponges, tunicates, bryozoans and sea anemones). Some of the organisms shown do not co-occur at any one site (from Foster et al. 1983).

### 3.2 DISTRIBUTION ALONG THE PACIFIC COAST OF NORTH AMERICA

#### 3.2.1 Giant Kelp Forests

Stands of *Macrocystis pyrifera* occur as far north as Año Nuevo Island, approximately 30 km north of Santa Cruz in central California (North 1971b, Druehl 1970; Foster pers. obs.; Figure 7). The species does not occur in Oregon (Phinney 1977) or British Columbia (Scagel 1967). Stands can occur as far south as Punta Asuncion-Punta San Hipolito in Baja California, Mexico (27°N lat.; Dawson

1951, North 1971b), but this southern limit varies. Estes (pers. comm.) reported that as of the summer of 1984, the most southerly plants were around the San Benito Islands, over 240 km north-west of Punta Asuncion-Punta San Hipolito. This probably reflects the effects of storms and changes in water characteristics associated with the recent "El Nino" (see Chapter 3). In California, giant kelp canopies occupy an area of about 110 km<sup>2</sup> (Miller and Geibel 1973), although this is highly variable between seasons and years (see Section 3.5).

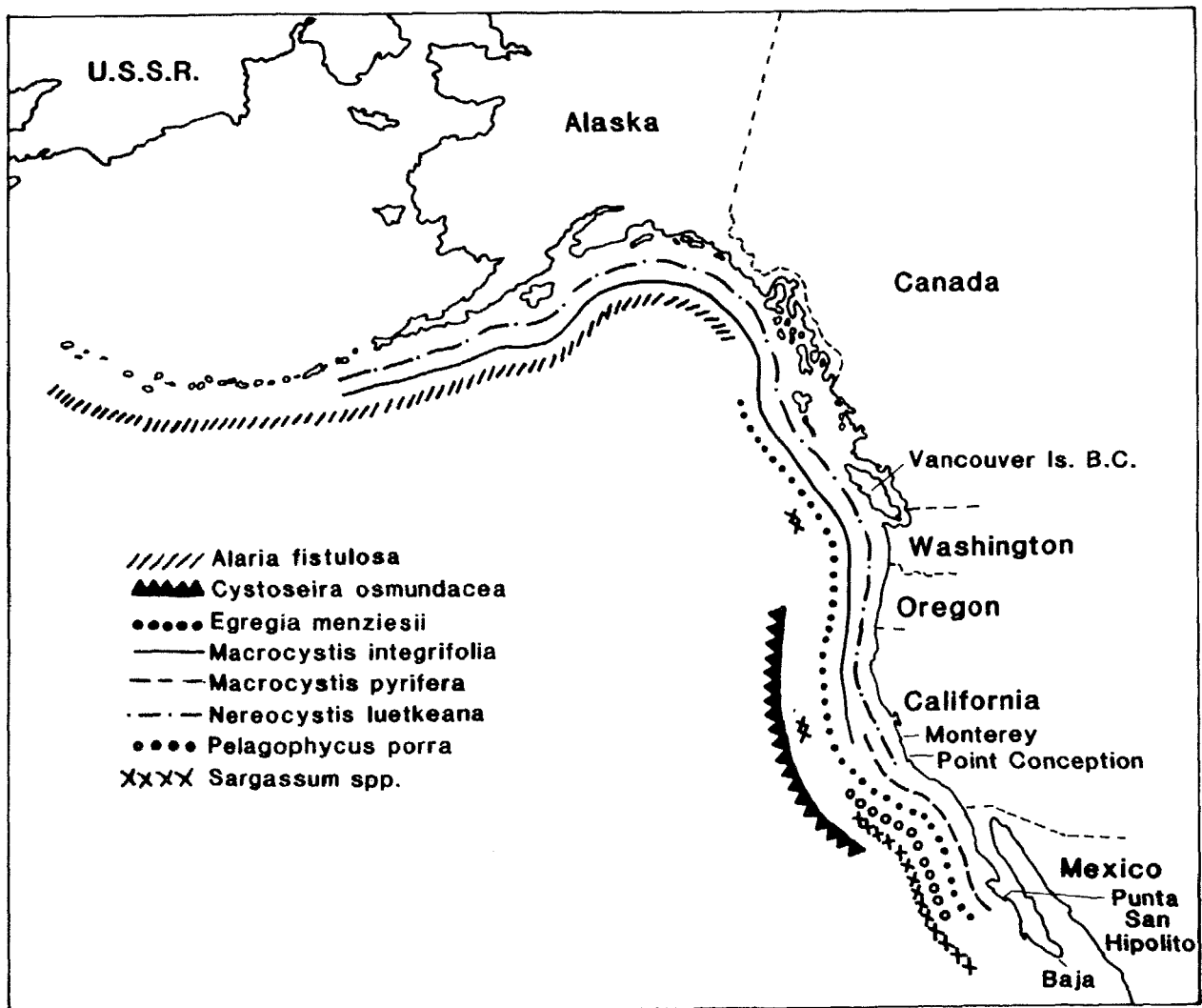

Figure 7. The distribution of algae that form surface canopies in the northeast Pacific (redrawn from Druehl 1970).



### 3.2.2 Other Kelp Forests

Bull kelp, *Nereocystis luetkeana* (Figure 3), occurs from near Point Conception, California, to the eastern Aleutian Islands, Alaska (Druehl 1970), and is the most abundant surface canopy kelp in California north of Santa Cruz (Figure 7). Where its range overlaps with *Macrocystis pyrifera*, the two plants can occur both in separate and mixed stands (Yellin et al. 1977). Another kelp, *Alaria fistulosa*, can also form surface canopies in Alaska (Druehl 1970, Dayton 1975). *Macrocystis integrifolia*, a low intertidal-shallow subtidal species, has a range similar to that of the bull kelp (Druehl [1970] indicates Monterey as its southern limit), and may form thick canopies in shallow, protected water (< 8 m deep; Scagel 1967). *Egregia menziesii* (Figure 3), the feather boa kelp, occurs from Baja California, Mexico to British Columbia (Druehl 1970, Abbott and Hollenberg 1976), and often forms a sparse canopy inshore from stands of *M. pyrifera*.

There are no surface canopy kelps in the eastern north Pacific south of the range of *Macrocystis pyrifera*. Members of the fucallean (Phylum Phaeophyta, Order Fucales) genus *Sargassum* may form surface canopies in the shallow waters of the Gulf of Mexico and the Gulf of California. Species of *Sargassum*, especially the recently introduced *S. muticum* (Ambrose and Nelson 1982, Deysher and Norton 1982), may also form surface canopies in shallow water in British Columbia-Washington (Norton 1981, DeWreede 1983), and in southern California, particularly in protected areas around Catalina Island (Ambrose and Nelson 1982). *Cystoseira osmundacea* (Figure 3), a native fucallean, occurs from Ensenada, Baja California to Oregon (Abbott and Hollenberg 1976). This plant has a perennial vegetative base that produces long, floating, reproductive fronds in spring and summer. *Cystoseira* can occur as pure stands in shallow water, and mixes with other surface canopies in deeper water. It is generally not found as deep as kelps, and mixed canopies usually occur at the inner edge of kelp forests.

The only other kelp that can form a surface canopy in the eastern north

Pacific is the elk kelp, *Pelagophycus porra* (Figure 3). This huge plant generally does not reach the surface; its long, wide blades stream out in currents just beneath the surface or, in areas around Catalina Island, California, drape over the bottom. Plants are most common along the outer margins of *Macrocystis* forests around the southern Channel Islands and other southern California islands, and along the mainland from the San Benito Islands in Baja California to San Diego (Dawson et al. 1960, Abbott and Hollenberg 1976). These geographic distributions are summarized in Figure 7.

### 3.3 DISTRIBUTIONAL VARIATION AMONG SITES

The greatest difficulty in describing giant kelp forest communities is that only a few sites have been studied in detail, and as pointed out in Chapter 1, quantitative information on abundances versus depth is lacking. Thus, many of the generalizations about community structure and the processes that affect it are, at present, preliminary, and should be viewed with caution.

Given the complexity of kelp communities and the qualitative nature of most descriptive data, we have chosen to illustrate kelp forest variability by describing a few sites that have been studied in some detail. Ten sites (Figure 8) are examined in Sections 3.3.1 and

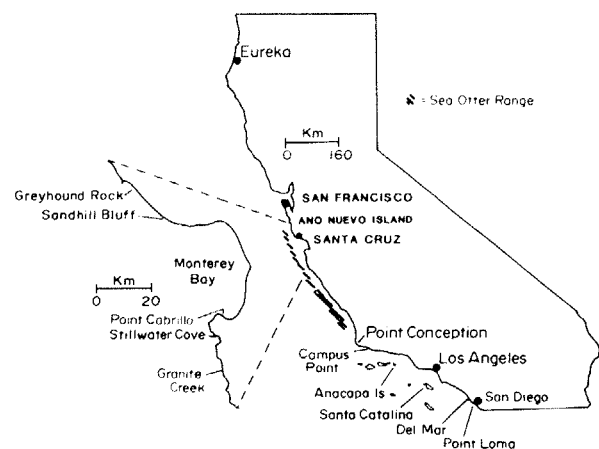

Figure 8. Location of the ten kelp forests described in Chapter 3.

3.3.2, five in central California (Figure 9), and five in southern California (Figure 10). Community composition in

other geographic areas is discussed in Section 3.3.3. It is impossible to discuss completely the large number of

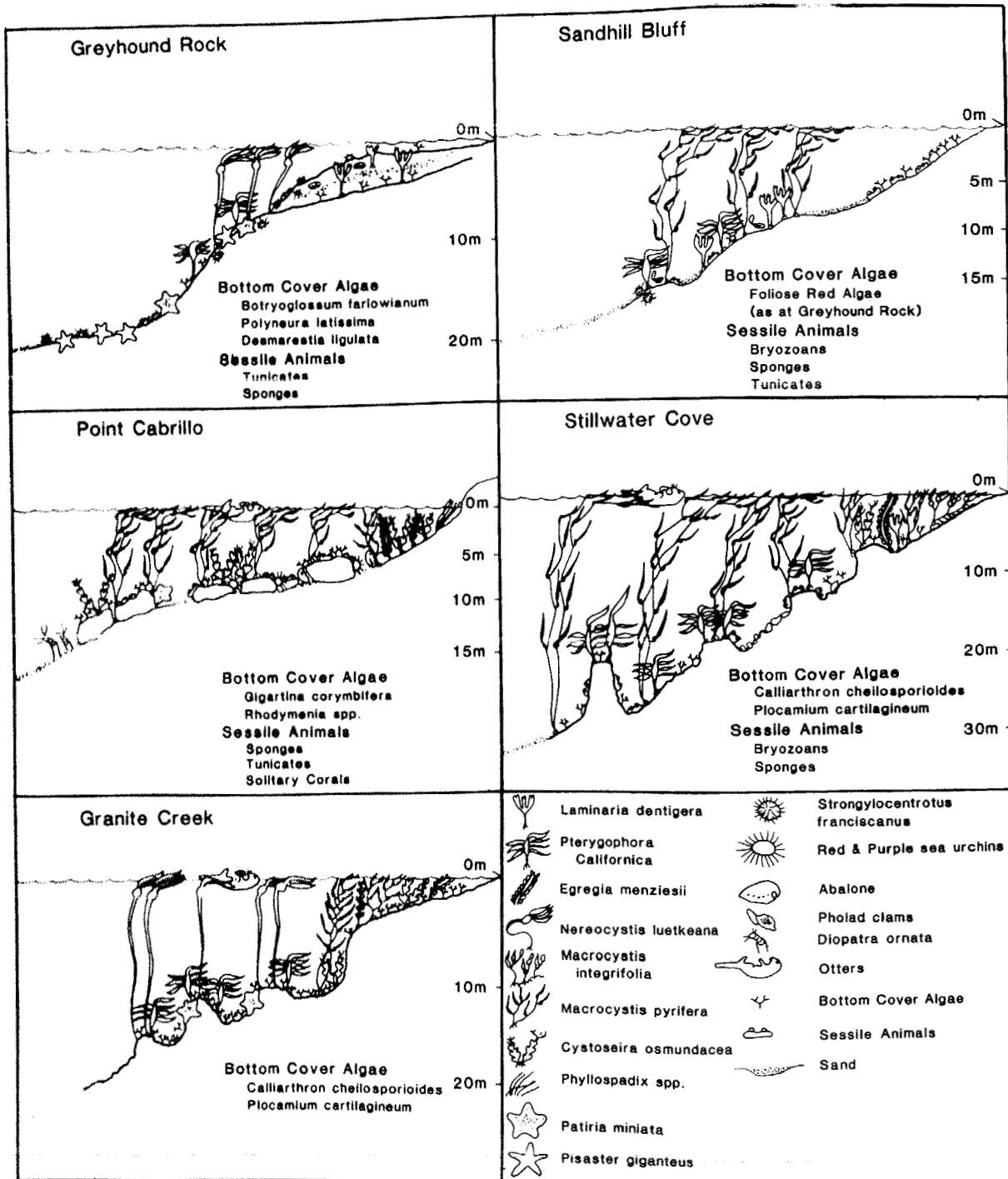

Figure 9. The distribution of conspicuous plants and animals found in five central California kelp forests. Horizontal axes are not to scale.

species that can occur in each kelp forest, so we will concentrate on the distribution of large, abundant organisms.

Details of the natural history of these plants and animals can be found in Chapter 4. A discussion of variation within sites

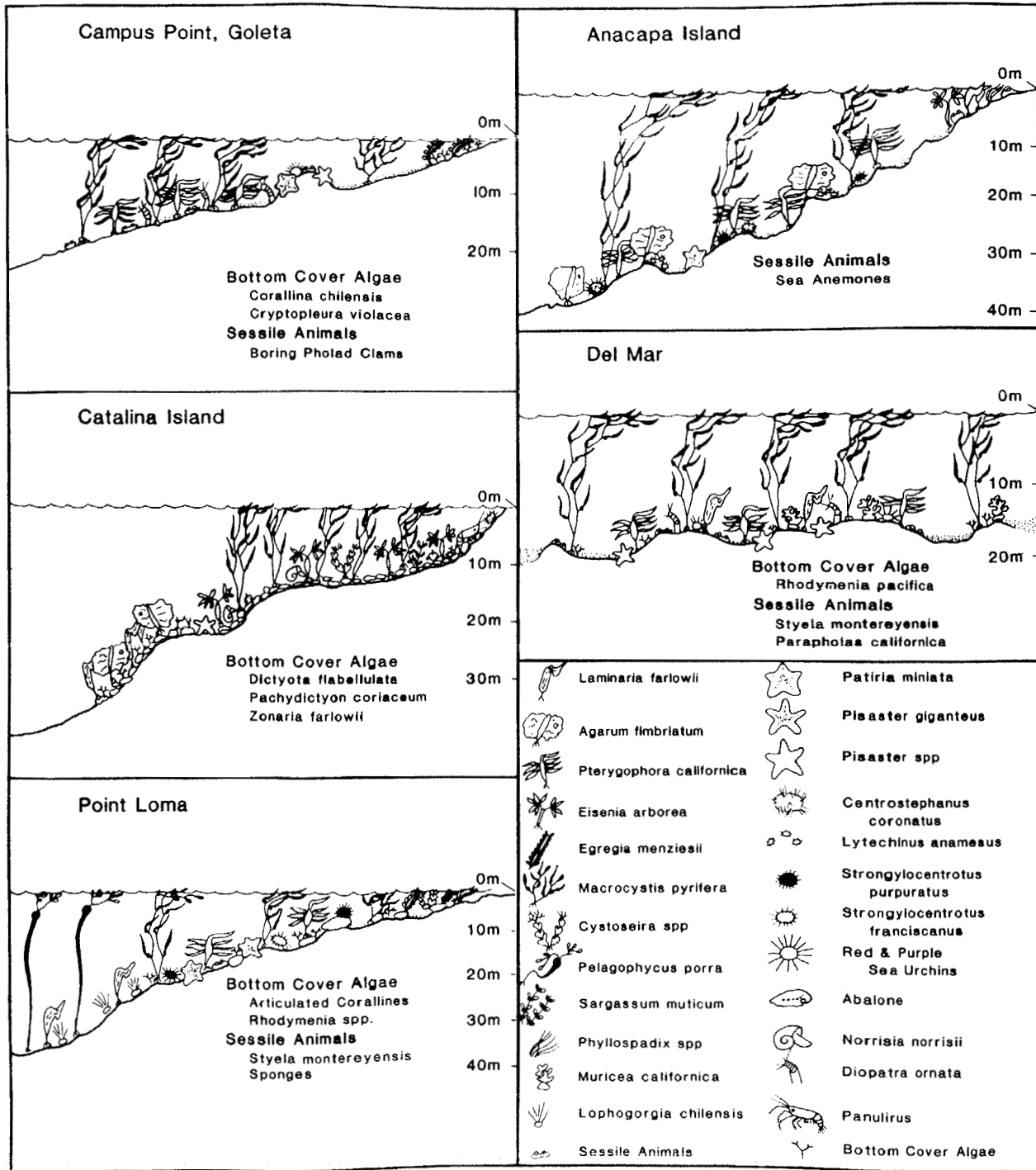

Figure 10. The distribution of conspicuous plants and animals found in five southern California kelp forests. Horizontal axes are not to scale.

follows the site descriptions (Section 3.4), and Chapter 5 examines in detail current hypotheses about the causes of variation within and among sites.

### 3.3.1 Central California

3.3.1.1 Greyhound Rock. The site is located 25 km north of Santa Cruz, and 4 km south of Ano Nuevo Island (Figure 8), the northern limit of large stands of Macrocystis pyrifera. Although a few small stands of Macrocystis occur to the north, Greyhound Rock is presently a Nereocystis luetkeana forest (Figure 9). It has been surveyed a number of times since 1976 (Yellin et al. 1977, Foster et al. 1979a, b, Foster and Reed 1980, Foster and Heine 1981, Foster 1982a).

The substratum is composed of mudstone ridges interspersed with sand that terminate in a large sand plain at ~ 20-m depth. The site is fully exposed to northwest swells and the water is generally turbid. At depths of 5-8 m inshore of the Nereocystis forest, the rocky ridges are covered with multiple layers of foliose vegetation (especially the red algae Botryoglossum farlowianum, Polyneura latissima, and Phycodrys setchellii, and the brown Desmarestia ligulata var. ligulata), along with scattered patches of the understory kelps Dictyoneurum californicum and Laminaria setchellii (L. dentigera in Abbott and Hollenberg 1976, but see Druehl 1979). The vertical sides of the ridges are covered with various tunicates and sponges, and the few red sea urchins (Strongylocentrotus franciscanus) present occur on the sides of ridges facing shore.

Nereocystis occurs on the tops of ridges at depths of 8-14 m. Beneath it are sparse stands of the understory kelps Laminaria setchellii and Pterygophora californica, with foliose algae beneath. The walls and ledges beneath the ridgetops are dominated by red sea urchins, encrusting coralline algae, sponges, tunicates, sea anemones, and solitary corals. Predatory sea stars (Pycnopodia helianthoides, Pisaster brevispinus, P. giganteus, and P. ochraceus) are common, as is the omnivorous bat star Patiria miniata.

Large, foliose algae are rare seaward of the Nereocystis stand (below 14 m), and the substratum is dominated by encrusting coralline algae, barnacles (Balanus crenatus), sea anemones (Corynactis californica), red sea urchins, and sea stars (especially Pisaster spp.). Fishes at this site have not been studied.

3.3.1.2 Sandhill Bluff. This site is a Macrocystis pyrifera forest located 10 km south of Greyhound Rock (Figure 8). The area is described in the literature cited under Greyhound Rock above and in Cowen et al. (1982). The rocky substratum is relatively flat mudstone interspersed with sand patches (Figure 9). In deeper water (14 to 17 m) beyond the kelp forest, rock terminates in an entirely sand bottom. The kelp forest is in the lee of a small point, and is thus slightly protected from northwest swells.

Macrocystis pyrifera forms a surface canopy at depths between 6 and 14 m (Figure 9). Along the inshore edge of the forest where giant kelp is absent, the bottom is dominated by foliose red algal species similar to those at Greyhound Rock but, at this site, these plants grow over dense mats of bryozoans, sponges, and tunicates. Where a surface canopy is present, the algal understory is reduced. Small Pterygophora californica and Laminaria setchellii occur in widely-dispersed patches. Factors affecting the algal assemblage at this site are shown in Figure 5.

Understory algal cover is reduced beneath the Macrocystis canopy. Sponges, tunicates, and pholad clams are common, but over 50% of the substratum can be unoccupied rock. Red sea urchin abundance is low (< 1/m<sup>2</sup>), and individuals are clumped in small crevices and depressions. The sea stars Patiria miniata, Pycnopodia helianthoides and Pisaster spp. are common.

Offshore from the giant kelp canopy, foliose red algal cover is greater and understory kelps are less abundant. The tube polychaete Diopatra ornata, the anemone Corynactis californica, and compound tunicates cover much of the substratum. Sea stars found under the canopy are common offshore, and the

abundance of red sea urchins increases to over 1/m<sup>2</sup>. Striped surfperch, Embiotoca lateralis, are abundant at this site (Cowen 1979), but other fishes have not been studied.

We noted an increase in sea otter abundance and a decline in red sea urchins at both Sandhill Bluff and Greyhound Rock during qualitative surveys in August, 1983. Whether this decline was associated with the severe storms in winter 1982-83, sea otter foraging, or some other cause is unknown.

### 3.3.1.3 Point Cabrillo kelp forest.

This forest, located in southern Monterey Bay off Hopkins Marine Station in Pacific Grove (Figure 8), has been extensively studied (Lowry and Pearse 1973, Miller and Geibel 1973, Devinny and Kirkwood 1974, Pearse and Lowry 1974, Lowry et al. 1974, Harrold 1981, Riedman et al. 1981, Breda 1982, Hines 1982, Hines and Pearse 1982, Fadlallah 1983, Watanabe 1983, 1984a, b). Seventy-seven species of algae, 292 species of invertebrates, 59 species of fishes, and various birds and mammals including the sea otter and harbor seals occur at Point Cabrillo (Miller and Geibel 1973, Pearse and Lowry 1974). The surface canopy is Macrocystis pyrifera and Cystoseira osmundacea that grows attached to large granite outcrops and boulders in an area very protected from swells (Figure 9).

Here, Macrocystis grows in very shallow water (~ 3 m). Extensive beds of surf grass, Phyllospadix spp., patches of the feather boa kelp Egregia menziesii, and in summer, dense masses of the floating reproductive fronds of Cystoseira osmundacea occur inshore of the giant kelp; C. osmundacea also occurs intermixed with Macrocystis out to 14 m (Schiel in press a). Beyond 14 m, the rock is replaced by sand, with abundant tube-dwelling polychaetes (Diopatra ornata), and sea anemones (Pachycerianthus sp.).

The kelp Dictyoneuropsis reticulata forms a sparse understory beneath the surface canopy, and the bottom is dominated by the foliose red algae Gigartina corymbifera, Rhodymenia spp., Botryocladia pseudodichotoma, Prionitis

lanceolata and encrusting corallines. Sponges, tunicates, anemones, bryozoans, hydroids, and solitary corals are common, particularly on the sides of rocks. Spider crabs occupy a number of different subhabitats in the forest (Hines 1982), and various turban snails (Tegula spp., Calliostoma spp.) are abundant, especially on the algae (Lowry et al. 1974). Red and purple sea urchins and abalone (Haliotis rufescens and H. walallensis) are common in crevices (Lowry and Pearse 1973). A variety of sea stars is found in this kelp forest (Harrold 1981), with Patiria miniata most abundant. Miller and Geibel (1973) described the fishes at Point Cabrillo in 1969 and 1970. The most abundant were juvenile rockfish, followed by adult blue rockfish. Other common species included kelp bass; striped, pile, black, and rainbow surfperch; kelp rockfish; greenling; and seniorita.

3.3.1.4 Stillwater Cove. This stand of giant kelp is located inside Carmel Bay about 5 km south of Monterey (Figure 8). The site has been described by Andrews (1945), Foster et al. (1979a, b), Foster (1982a), and Reed and Foster (1984). It faces south and is thus protected from northwest swells. The conglomerate and sandstone bottom is a mosaic of plateaus and pinnacles surrounded by relatively flat rock or fields of small boulders. One stand of Macrocystis integrifolia occurs from the lower intertidal to a depth of ~ 1 m (Figure 9). Both Cystoseira osmundacea and Egregia menziesii occur with M. integrifolia and seaward into the M. pyrifera forest. The understory kelp Laminaria setchellii occurs in patches down to ~ 7 m, and bottom cover plants in shallow water include the brown alga Dictyota binghamiae, the articulated corallines Calliarthron cheilosporoides and C. tuberculosum, and encrusting corallines.

Macrocystis pyrifera occurs at depths between 2 and 30 m, terminating at a sand bottom in deep water. Beneath the Macrocystis are dense stands of the understory kelp Pterygophora californica. These plants are large (over 1 m tall), and particularly abundant on the tops of plateaus (Reed and Foster 1984). Articulated (Calliarthron tuberculosum,

Bossiella californica ssp. schmitti) and encrusting corallines cover most of the flat substratum beneath these Pterygophora stands. There are occasional spring-summer blooms of benthic diatoms and the fleshy red algae Botryoglossum farlowianum, Plocamium cartilagineum, and Laurencia subopposita, all commonly epiphytic on the articulated corallines. Sessile animals are again most abundant on vertical and sloping substrata, with bryozoans, sponges, solitary corals, and sea anemones being the most common. Factors affecting the algal assemblage are shown in Figure 5.

As at Point Cabrillo, grazing gastropods of the genus Tegula are extremely abundant, especially on Macrocystis pyrifera. Small (1-2 cm) purple sea urchins (Strongylocentrotus purpuratus) are common in the articulated coralline understory. Large urchins and abalone are rare, perhaps because this site lacks suitable cracks and crevices that serve as refuges from sea otter predation. The lined chiton Tonicella lineata is abundant on encrusting corallines. Patiria miniata is very abundant, but the densities of other stars are reduced relative to the sites discussed above.

Qualitative observations of fish have been made at this site since 1976 by students at Moss Landing Marine Laboratories. The most abundant groups are juvenile rockfish, adult blue and kelp rockfishes, various surfperches, and greenlings. Black-eyed gobies and sculpins are common on the bottom.

3.3.1.5 Granite Creek. The species composition and distribution of algae and invertebrates at this site south of Monterey (Figure 8) were studied by McLean (1962) between 1959 and 1961. At this time, the most abundant canopy kelp was Nereocystis luetkeana, growing on an irregular granite bottom fully exposed to swells. Both Macrocystis and Nereocystis have occurred at the site since 1961 (Foster pers. obs.).

In 1959-61, Egregia menziesii, Cystoseira osmundacea, and Macrocystis pyrifera formed a mixed canopy inshore (0-10 m depth) of Nereocystis. The bottom

in this area was almost completely covered by the articulated (Calliarthron cheilosporioides) and encrusting corallines, with occasional patches of Laminaria setchellii (Figure 9).

Nereocystis grew attached to the irregular substratum between 10 and 20 m. Rock was replaced by sand in deeper water. The understory beneath the bull kelp was dominated by dense stands of large Pterygophora californica. Other understory species included the kelp, Costaria costata, other brown algae (Desmarestia ligulata var. ligulata, Egregia menziesii, Cystoseira osmundacea, and Dictyota binghamiae) and the red alga Plocamium cartilagineum. These algae were particularly abundant on the tops of boulders where Pterygophora cover was sparse.

McLean (1962) lists 32 common invertebrate species on vertical walls in the kelp forest, and 13 on horizontal surfaces under the Pterygophora canopy. Chitons (Cryptochiton stelleri, Tonicella lineata) and the turban snail Tegula brunnea were common, as were Patiria miniata and Pycnopodia helianthoides. When surveyed, this area had recently been foraged by sea otters, and large red sea urchins were absent. Fishes have not been studied here.

### 3.3.2 Southern California

3.3.2.1 Campus Point, Goleta. This site is located at the northwest end of Goleta Bay approximately 16 km northwest of Santa Barbara (Figure 8). The description below is based on Neushul et al. (1976) and Foster (pers. obs.).

Like most of the mainland coast near Santa Barbara, Campus Point is protected from swells by Point Conception to the north, and the Channel Islands to the southwest. The bottom is low relief mudstone interspersed with extensive sandy areas and occasional rocky outcrops. Macrocystis pyrifera (M. angustifolia in Neushul et al. [1976]; see discussion in Chapter 1) occurs between depths of 5 and 20 m. At its inner edge, the kelp forest is bounded by patches of the feather boa kelp Egregia menziesii, and the bottom cover is composed of the red algae

Corallina chilensis, Lithothrix aspergillum (articulated corallines), Chondria nidifica, Cryptopleura violacea, and the brown, Zonaria farlowii (Figure 10). These plants commonly grow over a turf of Pterosiphonia dendroidea and other small red algae; all are frequently covered by sand, and the vegetation is best developed on slightly elevated rocks.

Pterygophora californica is the most common understory alga within the giant kelp forest, growing in dense stands separated by extensive sandy areas. Fleshy red algae (primarily Callophyllis spp., Cryptopleura violacea and Stenogramme interrupta) are sparse on exposed rocks and on the tubes of the polychaete Diopatra ornata. Much of the hard bottom is bare or occupied by rock-boring pholad clams. The whelk Kelletia kelletii and sea stars (Pisaster spp., Patiria miniata, Dermasterias imbricata) are common, and red and purple sea urchins are abundant on isolated rock outcrops.

Extensive areas of deep sand occur along the seaward border of the forest. Fishes have not been surveyed.

3.3.2.2 Anacapa Island. In contrast to the mainland, waters around the Channel Islands are generally clearer, high-relief rock is more common and, as discussed by Murray et al. (1980), there is greater spatial variability in temperature. The first two conditions are particularly favorable to the growth of giant kelp and other rocky subtidal organisms. Qualitative comparisons indicate that the diversity of kelp-forest organisms is high on the islands relative to the mainland. Ebeling et al. (1980a) suggested that the continuity of well-developed rocky reefs, clearer water, and the high density of algal and invertebrate turf (an important source of fish food) on the islands also contribute to increased density, biomass, and diversity of fish there versus the mainland. The discussion below is based on Neushul et al. (1967) and Clarke and Neushul (1967), who surveyed a 700-m long mixed sand-rock transect through a giant kelp forest at Anacapa Island (Figure 8) from 0 to 40-m depth (Figure 10).

These investigators recognized three broad zones along the transect. The first

was a shallow zone from 0 to 8 m with abundant understory kelps (Eisenia arborea, Laminaria farlowii), surfgrass (Phyllospadix torreyi), and sea anemones (Anthopleura xanthogrammica). Below this was a wide, mid-depth zone (8-34 m) of Macrocystis pyrifera growing over the understory kelps Agarum fimbriatum and Pterygophora californica. Common animals here included sea urchins (Strongylocentrotus franciscanus, S. purpuratus, Lytechinus anamesus), and bat stars (Patiria miniata). Macrocystis did not occur below 34 m; the final zone in deeper water was inhabited by A. fimbriatum and a variety of small red algae. Fishes were not surveyed, but off Santa Cruz Island to the west, such species as the senorita, kelp perch, giant kelpfish, blacksmith, and blue rockfish were common in midwater, while the California sheephead, opaleye, halfmoon, kelp bass, kelp rockfish, and various surfperches were common, both in midwater and on the bottom. Various rockfishes and gobies are common on the bottom (Ebeling et al. 1980a).

3.3.2.3 Santa Catalina Island. The relatively warm waters of the kelp forests at Santa Catalina Island (Figure 8), like Del Mar and Point Loma below, contain species not found in the more northern areas described above. Among the more conspicuous of these are elk kelp Pelagophycus porra, the sea urchin Centrostephanus coronatus, and the blue-banded goby Lythrypnus dalli. Dykzeul and Given (1979) reviewed the various marine and terrestrial habitats around the western end of Santa Catalina Island; the information below is summarized from their discussion of subtidal boulder habitats near Big Fisherman's Cove and from our personal observations.

The shallow subtidal zone east of Big Fisherman's Cove (Figure 10) is composed of metamorphic (schist) boulders of varying size that terminate in a sand plain at around 35 m. At depths of 0-8 m, the bottom is dominated by the understory kelp Eisenia arborea. The brown algae Cystoseira neglecta, Dictyota flabellulata, and Pachydictyon coriaceum are common on the bottom, as are the reds Lithothrix aspergillum, Plocamium sp., and

Pterocladia capillacea. Common invertebrates include red sea urchins (Strongylocentrotus franciscanus), keyhole limpets (Megathura crenulata), and spiny lobster (Panulirus interruptus). Conspicuous fishes include the opaleye, garibaldi, blacksmith, and topsmelt.

Macrocystis pyrifera occurs from ~8-20 m. The understory beneath its surface canopy is relatively reduced, with patches of Cystoseira neglecta, Sargassum muticum, Dictyota flabellulata, Pachydictyon coriaceum and various species of the red alga Gelidium, particularly where the surface canopy is thin or absent. Much of the bottom is covered by encrusting coralline algae. Invertebrates include those in shallow water plus the additional sea urchin Centrostephanus coronatus, Octopus bimaculatus, sea stars (Pisaster spp.), and the whelk Kelletia kelletii. The grazing gastropod Norrisia norrisi is common on Macrocystis. Fishes such as the seniorita, kelp perch, and blacksmith are common in mid-water and the Macrocystis surface canopy, while California sheephead, rock wrasse, seniorita, various surfperch, and gobies are abundant on and just above the bottom.

In deeper water outside the giant kelp canopy, the understory is again dominated by the kelp Eisenia arborea, as well as Agarum fimbriatum and Laminaria farlowii. The browns Zonaria farlowii and Dictyopteris undulata, encrusting and articulated corallines, and the red algal epiphyte Acrosorium uncinatum are present around and beneath the understory kelp canopy. The common benthic invertebrates in the deep area are sea urchins (Centrostephanus coronatus), sea stars (Henricia leviuscula, Linckia columbiae, Pisaster giganteus), snails (Norrisia norrisi, Tegula aureotincta), and various bryozoans. Black-eyed gobies are abundant on the bottom, while halfmoon, garibaldi, California sheephead, and seniorita are common just above the bottom and in mid-water.

3.3.2.4 Del Mar. Rosenthal et al. (1974) made extensive observations of the organisms in a small kelp stand off Del Mar (Figure 8) approximately 25 km north of San Diego. This study, done between 1967 and 1973, is the most thorough, long-

term natural history study published on a kelp forest. Community composition is summarized below, and temporal patterns will be discussed in Section 3.4.

Like many mainland southern California giant kelp forests, the stand at Del Mar is isolated by a surrounding sand bottom. Plants in the stand occur on a mixed sandstone and siltstone bottom, with large areas of sand and silt among the rock. The depth of this low relief area is between 14 and 20 m. As in the other areas described above, the understory vegetation beneath the Macrocystis pyrifera was relatively sparse, with only occasional individuals of Pterygophora californica and Laminaria farlowii, and a few foliose brown (Desmarestia ligulata var. ligulata) and red (Rhodomenia pacifica) algae. Most of the bottom was covered with encrusting corallines (Figure 10).

Ninety-eight species of epibenthic invertebrates were identified by Rosenthal et al. (1974) in the kelp forest, the most common larger species being the tube polychaete Diopatra ornata, the solitary tunicate Styela montereyensis, the gorgonian Muricea californica, the whelk Kelletia kelletii, and the rock boring clam Parapholas californica. Pisaster giganteus was the most conspicuous sea star. Both red and purple sea urchins were present, though not abundant, and were largely restricted to rock mounds and boulders as they are at Campus Point (described above).

Thirty-eight species of fishes were observed, and included most of those common on reefs and in kelp forests in southern California (see Chapter 4, Section 4.5).

3.3.2.5 Point Loma. The Point Loma kelp forest is located along the western shore of Point Loma between the entrance of Mission Bay and San Diego Bay (Figure 8). This kelp forest was ~11 km long and 1 km wide in 1977 (Bernstein and Jung 1979), but has varied greatly in extent since the early 1900's (North 1969, Dayton et al. 1984). It was extensively surveyed by Turner et al. (1968) to detect possible effects of the San Diego sewer outfall. Given such a large area, one might expect



considerable spatial variation within the forest, as is evident from a comparison of the four transects surveyed by Turner et al. (1968). This spatial variation will be discussed in Section 3.4. Below we describe an idealized transect (Figure 10), summarizing and combining the data from all the transects surveyed. Surveys have also been done in the nearby kelp forest at La Jolla (Aleem 1956, 1973; Neushul 1965), but are not discussed here.

The kelp forest occurs on a broad, gently-sloping mudstone-sandstone terrace with pockets of sand, cobbles and boulders. Macrocystis pyrifera was most abundant between 6 and 25 m on rocky substrata. Inshore of the giant kelp forest, the surf grass Phyllospadix torreyi was particularly abundant, along with the surface canopy brown algae Egrecia menziesii and Cystoseira osmundacea. Articulated corallines were also common, as were black perch and senorita.

When Turner et al. (1968) studied Point Loma, giant kelp was sparse, particularly on the more northerly transects. Understory kelps were patchy in occurrence but common, with Pterygophora californica most abundant. Common bottom cover algae included articulated corallines and Rhodomenia spp. The sea anemone Corynactis californica, the solitary coral Balanophyllia elegans, the solitary tunicate Styela montereyensis, and various sponges were the most common sessile animals. The whelk Kelletia kelletii, bat stars, and red and white sea urchins were the more common mobile invertebrates. Red urchins appeared to be keeping some areas clear of foliose macroalgae. The most common fish within the kelp forest were blacksmith, senorita, California sheephead, kelp bass, and the black-eyed goby.

The terrace sloped more steeply beyond 25 m depth, and in this deep region outside the giant kelp canopy or occasionally mixed with it, occurred the elk kelp Pelagophycus porra. Beneath were sparse stands of Laminaria farlowii, and a reduced bottom cover of articulated corallines, Rhodomenia spp. and Plocamium cartilagineum. Invertebrates here were similar to, but less diverse than, those

at the outer edge of the giant kelp forest; the gorgonian Lophogorgia chilensis was particularly abundant. Red urchins were absent. The fishes, like the invertebrates, were generally similar to those found within the giant kelp forest.

### 3.3.3 Other Geographic Areas

With the exception of a number of recent papers on South American kelp forests, little information is available on subtidal Macrocystis communities in other parts of the world. Kuhnemann (1970) described the vertical structure of the vegetation in kelp forests in southern Argentina. Canopy layering is similar to forests in California but, with the exception of Macrocystis pyrifera, the species composition is very different. Barrales and Lobban (1975) surveyed seven sites on the coast of Argentina in March 1974, and found M. pyrifera to occur from the low intertidal to a depth of 15 m. Plants were excluded from deeper water by lack of hard substrata. The species composition of associated organisms varied with exposure to oceanic swells. Barrales and Lobban (1975) suggested that Macrocystis in this region goes through a three- to four-year loss-replacement cycle caused by holdfast deterioration and storms. Older holdfasts are apparently weakened by a boring isopod (Phycolimmoria sp.) and become susceptible to removal by surge after three to four years of growth. These authors also suggested that this regular loss-replacement cycle contributes to the low species diversity of these forests relative to those in California. However, some forests in California can exhibit similar cycles (see Section 3.5.1). Sea urchins were not abundant at these South American sites, and appeared to have little impact on the community.

Giant kelp forests in southern Chile are also apparently limited to shallow water by lack of suitable substrata, and their inner margins can be determined by competition with understory kelps (Santelices and Ojeda 1984b). These authors suggested that the Macrocystis pyrifera loss-replacement cycle described by Barrales and Lobban (1975) in Argentina does not occur at their site. Two species of the kelp, Lessonia, form understory canopies in southern Chile, and foliose

red algae are common on the bottom. Experiments by Castilla and Moreno (1982) indicated that the four species of sea urchins inhabiting this area feed on drift algae and have little impact on Macrocystis recruitment, growth, or survivorship. The Macrocystis holdfast fauna is less diverse than that in California (Ojeda and Santelices 1984), as are the fish associated with the forest (Moreno and Jara 1984).

More northerly Chilean kelp forests studied by Moreno and Sutherland (1982) are also often limited to shallow water by lack of hard substrata, and giant kelp abundance is regulated primarily by water motion and not herbivorous urchins or molluscs.

### 3.4 DISTRIBUTIONAL VARIATION WITHIN SITES

#### 3.4.1 Between Depths

Although considerable variation in distribution with depth exists both between and within sites (see Section 3.3; Turner et al. 1968), a general pattern of algal distribution emerges from the California sites above. If rocky substratum is available from the low intertidal to depths where light is insufficient for macroalgal growth, three subtidal zones can be recognized, similar to those proposed by Neushul (1965; Figure 6).

Zone 1, inshore of Macrocystis, is commonly inhabited by Phyllospadix spp. (surf grass), feather boa kelp (Egria menziesii), and Cystoseira osmundacea. Depending on geographic location and exposure to swell, Eisenia arborea, Pterygophora californica, Laminaria spp., various species of Sargassum, and articulated corallines may be present. Macrocystis is most abundant in Zone 2, may be mixed with C. osmundacea throughout California, and may be mixed with, or replaced by, Nereocystis luetkeana in central California. Various understory kelps (particularly P. californica and L. farlowii) occur in patches under Macrocystis, and articulated (especially Calliarthron spp.) and encrusting corallines are most common on the bottom. Zone 3, seaward of the Macrocystis canopy, may be inhabited by Pelagophycus porra in

southern California, or more commonly by sparse stands of understory kelps such as Agarum fimbriatum and L. farlowii, encrusting corallines, and small foliose red algae.

Invertebrate zonation is not as distinct, although broad changes along a depth gradient in the distribution of sea urchins have been noted (purple urchins in shallow water, red urchins at mid-depths, and in southern California, white urchins and Centrostephanus coronatus in deeper water). But there are numerous exceptions: e.g., Sandhill Bluff above, and other areas where red urchins are most abundant at the outer edge of giant kelp distribution (Yellin et al. 1977, Pearse and Hines 1979). Three common species of turban snails (Tegula) in central California also occur in different depth zones subtidally: T. brunnea at 0-6 m, T. montereyi at 3-9 m, T. polligo at 7-12 m (Riedman et al. 1981, Watanabe 1984a). In general, sessile invertebrate abundance increases with depth (Aleem 1973), perhaps in part due to reduced competition for space with algae (Foster 1975b).

The distribution and abundance of fish species are often not clearly zoned along a depth gradient. Distribution appears most strongly related to vertical relief, including that due to vegetation, rather than depth (Quast 1971a, Ebeling et al. 1980a, Moreno and Jara 1984, Larson and DeMartini in press; see Section 4.5). Within continuous reef habitats, however, closely related species may segregate with depth (Hixon 1980, Larson 1980a).

#### 3.4.2 Within Depths

Few published surveys discuss the distributional variation of plants or animals within depths, but qualitative observations and the high variances associated with abundance estimates at any particular depth (Rosenthal et al. 1974, Foster et al. 1979a, Pearse and Hines 1979) suggest that distributions are generally clumped at fairly small scales. This variability can result from a number of processes, including variability in distribution of many abiotic factors discussed in Chapter 2, as well as environmental changes created by the

organisms themselves, particularly by the large kelps. Kelps in dense stands can effectively exclude many other algae (Reed and Foster 1984, Dayton et al. 1984). Moreover, the dispersal range of many large kelps is probably only several meters from attached adults (Anderson and North 1966, Schiel 1981) contributing to the maintenance of local stands. Dispersal distances for invertebrates can also be quite short (Ostarello 1976, Gerrodette 1981). Inhibition of settlement by established sessile organisms (Breitburg 1984), local grazing by sea urchins (Turner et al. 1968, Vance 1979, Cowen et al. 1982, Dean et al. 1984, Harrold and Reed in press) predator-prey interactions (Bernstein and Jung 1979, Schmitt 1982), territorial behavior and competitive interactions among fish (Clarke 1970, Hixon 1980, Larson 1980a), physical disturbance (Cowen et al. 1982, Wells 1983) and competition among algae (Kastendiek 1982, Reed and Foster 1984, Dayton et al. 1984) also contribute to variations in distribution. Stochastic events are probably also important, but detailed descriptions necessary to detect them have not been done. However, in these diverse and structurally complex communities, most of the patterns of within-depth distribution remain undescribed, and the mechanisms creating these patterns are unknown -- a fruitful area for further research.

### 3.5 TEMPORAL VARIATION IN COMMUNITY STRUCTURE

#### 3.5.1 Long-Term (> 5 years)

The best records of long-term (> 5 years) changes in California kelp forests come from maps of kelp canopy distribution, the first of which were made in 1910, 1911, and 1912 (McFarland 1912, Crandall 1915). Comparisons with recent surveys indicate an overall 30%-70% decline in the area of giant kelp canopies in southern California since these early surveys (Hodder and Mel 1978, Neushul 1981). Hodder and Mel (1978), however, suggested that the magnitude of the decline may be, in part, an artifact of differences in canopy-mapping techniques. Sewage pollution (Leighton et al. 1966,

Grigg and Kiwala 1970, Wilson 1982, Meistrell and Montagne 1983), abnormal oceanographic conditions ("El Nino" years: warm water, low nutrients; Jackson 1977), and sea urchin grazing (Leighton et al. 1966, North 1974) stimulated by sewage (North 1974) and/or removal of sea urchin predators by man (North 1974, Tegner and Dayton 1981) have all been implicated as causative agents. As these factors may all affect canopy distribution, and because information about organisms in the community other than Macrocystis and Nereocystis is almost non-existent prior to the 1950's, we will probably never know what did happen. However, Macrocystis has begun to return to the Palos Verdes Peninsula coincident with reduction in sludge and DDT discharge from the White's Point sewer outfall (Wilson 1982). This suggests that sewage pollution, and particularly increased turbidity (Meistrell and Montagne 1983) and sludge accumulation on the bottom (Grigg and Kiwala 1970), had important direct effects on the decline of giant kelp around southern California sewer outfalls.

Long-term changes in central California may be associated with changes in the abundance and distribution of sea otter populations. Van Blaricom (in press) has compared canopy distribution data from the early 1900's (when sea otters were essentially absent) with recent surveys (sea otters present). He suggests that the Macrocystis canopy area has recently increased and Nereocystis luetkeana has decreased as an indirect result of sea urchin removal by sea otters.

The production, dispersal, and recruitment of larvae can be periodic phenomena. Little is known of the relationship of production and dispersal to recruitment because little is known about larval mortality, particularly for planktonic larvae. Large-scale temporal patterns of some invertebrate (Dayton and Tegner 1984a) and fish distributions (Miller and Geibel 1973) in kelp forests have been correlated with recruitment. Small scale patterns in sea urchin (North 1983a), Tegula spp. (Watanabe 1984a), and spider crab (Hines 1982) recruitment have been shown or suggested as important to the population dynamics of these species.

On a shorter time scale (1-5 years), changes have been associated with year-to-year variations in storm-swell intensity. Ebeling et al. (MS.) has made long-term observations of a kelp forest on an isolated reef near Santa Barbara. Large waves in 1980-81 removed most of the Macrocystis from the reef. Sea urchins then came out of cracks and crevices and actively grazed over the substratum. This grazing not only removed most of the remaining non-encrusting algae, but also prevented the re-establishment of these plants. The more severe storms of 1982-83 reduced the abundance of these exposed sea urchins, and macroalgae, including Macrocystis, have subsequently recolonized the area. Ebeling et al. (MS.) found that these changes also affect fishes, particularly surfperch, as the juveniles use Pterygophora californica as shelter from predators, and the adults forage for invertebrate food among the algae that cover the bottom. Abnormally stormy years can also have dramatic long-term effects in central California, altering understory abundance both by direct removal, and via increased light from surface canopy removal (Foster 1982a).

There have been historical changes in the relative abundance and distribution of M. pyrifera and Nereocystis luetkeana in central California, with particular sites changing completely or partially from giant to bull kelp and vice versa (Yellin et al. 1977, Van Blaricom in press). Numerous causes are possible. Storms appear to affect surface canopy type, with Nereocystis replacing Macrocystis after the latter has been removed by severe water motion (Foster 1982a, Van Blaricom in press). In addition, variations in sea urchin grazing may affect species composition (Van Blaricom in press) and kelp forest size (Pearse and Hines 1979). Storms can also indirectly affect entire forests, as storm-induced sand movement can change kelp forests into soft-bottom communities (North 1971b, Grant et al. 1982, LOSL 1983).

### 3.5.2 Short-Term (< 1 year)

The relative lack of large seasonal changes in the local ocean climate, particularly storms, appears to result in reduced seasonal variability in kelp

forest communities in southern California (Rosenthal et al. 1974, SCE 1978). These and other studies (North 1971b, Dean pers. comm.) suggest that many southern California kelp canopies go through a three- to five-year cycle of abundance and decline, perhaps associated with holdfast deterioration in older plants. However, even without unusually high water motion, mortality of adult plants is about 40% per year in the kelp forest at San Onofre (Dean pers. comm.).

In central California, the larger and more frequent winter swells produce a regular seasonal canopy cycle with a maximum canopy size in summer, and a minimum in winter (Miller and Geibel 1973, Gerard 1976, Foster 1982a, Reed and Foster 1984, Kimura and Foster in press). These storms can also influence understory algal abundance (Foster 1982a). Productivity, growth rate, and recruitment of understory algae also change seasonally in response to climatic conditions and cover of surface canopies (Johansen and Austin 1970, Breda 1982, Heine 1983, Reed and Foster 1984, Kimura and Foster in press). Seasonal changes in sand cover can also be important (Breda 1982). In addition, juvenile rockfish commonly recruit into central California kelp forests during the strong upwelling period in late spring-early summer (Miller and Geibel 1973). The effects of seasonal climatic changes appear to increase with latitude, as shown in the distinct summer-winter differences in Nereocystis luetkeana forests in Washington (Neushul 1967).

### 3.5.3 Succession

The causes of both long- and short-term changes in community composition, such as spatial patterns, are a complex of interacting factors of which only the extremes of storms and grazing have been clearly documented in particular forests. These disturbances initiate successional changes that remain largely unexplored. Foster (1975a) found that successional events on small concrete blocks placed within a kelp forest were largely determined by the availability of larvae or spores in the water, and differences in growth rates and competitive abilities among colonizing species. Aside from a possible initial

enhancement of colonization by microalgal or bacterial films, there was no evidence for facilitative interactions (*sensu* Connell and Slatyer 1977). Macrocystis can be among the first organisms to settle and grow if spores, space, and light are adequate. Similar patterns were noted by Fager (1971) on isolated structures placed some distance from a kelp forest, while Kennelly (1983) has shown on a microscopic scale that most species associated with an Ecklonia radiata bed in Australia have the potential of quickly recruiting on artificial substrata.

The above examples mimic extreme disturbances where small patches of natural substratum are completely cleared. All organisms are not generally removed during normal disturbances in kelp forests, and the processes involved in succession after more natural disturbances remain generally uninvestigated (see review in Foster and Sousa in press). Reed and Foster (1984) demonstrated that, with less extreme disturbance, changes in overstory canopies are particularly important to subsequent successional events. Van Blaricom (in press) suggested that in central California Nereocystis luetkeana first colonizes areas where sea otters remove sea urchins because this annual kelp is more common than Macrocystis (i.e., more spores available for colonization). Macrocystis then gradually invades these areas, and in the absence of storms which seem to have a greater impact on Macrocystis, the perennial giant kelp eventually replaces bull kelp, as the canopy of the former reduces light and thereby restricts recruitment of the latter. This sequence may be altered if perennial understory kelps (Laminaria, Pterygophora) invade after the initial disturbance (storms, grazer removal), and inhibit further recruitment (Van Blaricom in press). An increase in understory foliose red algae could also inhibit recruitment of all kelps (Kimura pers. comm.).

Various other interactions may also alter succession. Predators may directly alter sessile invertebrate abundance (Foster 1975b, Neushul et al. 1976) and species composition (Day and Osman 1981), and these changes may indirectly affect algal succession by reducing competition

for space (Foster 1975b). Grazing (probably by fish) may alter algal species composition (Foster 1975b), and small algal turf species may facilitate the survivorship of young kelp sporophytes by providing a refuge from fish grazing (Harris et al. 1984). Small herbivores may alter early successional patterns in Ecklonia radiata beds (Kennelly 1983, pers. comm.). After incomplete removal of sessile organisms, remaining encrusting corallines can inhibit recruitment of numerous sessile invertebrates (Breitburg 1984), and encrusting and articulated corallines may inhibit Macrocystis recruitment (Wells 1983).

Additional effects associated with the magnitude and extent of disturbance, micrograzers and predators, sedimentation, etc., as well as competition for light, dispersal, and basic life history characteristics of the organisms involved are no doubt also important to kelp forest succession (Foster and Sousa in press), but remain to be investigated in detail.

### 3.6 BIOMASS, PRODUCTIVITY, AND ENERGY FLOW

#### 3.6.1 Introduction

Not surprisingly, giant kelp communities are highly productive; nutrients are generally high in nearshore waters, and Macrocystis can form a dense, light-absorbing canopy at the water's surface. The production of Macrocystis, understory kelps, and bottom-cover algae, together with energy imported from the plankton, support consumers in giant kelp forests as well as in nearby communities receiving drift from forests. These processes, as well as food webs within the Macrocystis community, are reviewed in detail in this section.

#### 3.6.2 Biomass (Standing Stocks)

Coon (1982) recently compiled the available information on biomass and productivity of eastern north Pacific Macrocystis. Table 4 summarizes these values for Macrocystis, and includes additional estimates for understory algae, sessile invertebrates, and fishes. Other than the few quadrats sampled by Aleem

Table 4. Kelp forest biomass/m<sup>2</sup> of bottom (includes water column from surface to bottom).

Location	Wet kg/m <sup>2</sup>	Reference
<u>Macrocystis pyrifera</u> <sup>a</sup>		
La Jolla, California	6 -10	Aleem 1973
Southern California and Baja California, Mexico	3 -22	North 1971b
Paradise Cove, California	4.4 - 5.8	McFarland and Prescott 1959
Goleta, California	7 - 9	Coon 1982
Pacific Grove, California	5.9	Towle and Pearse 1973
Pacific Grove, California	0.7 - 6.3	Gerard 1976
British Columbia <sup>b</sup>	4.2 - 4.7	Field and Clark 1978
<u>Understory Algae (Other Than Macrocystis) Within Macrocystis Forests</u>		
La Jolla, California	4.8	Aleem 1973
Bird Rock, California	0.47	North 1971b
Paradise Cove, California	0.02- 0.5	McFarland and Prescott 1959
Monterey, California <sup>c</sup>	0.03- 0.7	Breda 1982
Monterey, California	2.0	Pearse and Hines 1976
Monterey, California	2.4 - 5.2	Gerard and Garrison 1971
Santa Cruz, California <sup>c</sup>	0.07- 0.9	Breda 1982
Santa Cruz, California	0.02- 0.04	Pearse and Hines 1979
<u>Benthic Invertebrates</u> <sup>d</sup>		
Baja California, Mexico	0.6	Woollacott and North 1971
La Jolla, California	0.11- 0.41 <sup>e</sup>	Aleem 1973
Monterey, California	0.025- 0.37	Gerard and Garrison 1971
<u>Fish</u>		
Southern California and Mexico	0.01- 0.046	Quast 1971b
Pacific Grove, California	0.07- 0.11	Miller and Geibel 1973

<sup>a</sup>Modified from Coon 1982.

<sup>b</sup>Mixed Macrocystis integrifolia and Nereocystis luetkeana.

<sup>c</sup>Data from Breda (1982) for red algae only, and converted from dry weight values (dry = 0.12 wet).

<sup>d</sup>Estimates do not include large, mobile invertebrates, those on plants, or those living in kelp holdfasts.

<sup>e</sup>Includes mobile invertebrates on the bottom.

(1973), we could find no published data on the biomass of mobile invertebrates, even though these animals can be quite abundant and trophically important (see below). As Table 4 shows, Macrocystis biomass can vary by more than an order of magnitude. This variation is probably the result of differences in sampling methods and sample size (few samples in a patchy environment), differences in sampling times, and real differences within and among kelp forests. Gerard's (1976) data are most representative of a single site as she sampled over 2.5 years in the same area, and found that giant kelp biomass varied from 0.7 to 6.3 wet kg/m<sup>2</sup> (mean = 3.5). This large within-forest variation for Macrocystis (and, when determined, other groups of organisms as well; see below) clearly indicates that one sampling cannot characterize biomass in these spatially and temporally variable communities.

The values for Macrocystis can be compared with other temperate nearshore kelp communities. Kain's (1979) review of Laminaria spp. suggests the "typical" biomass of this genus in Laminaria beds is ~ 10 wet kg/m<sup>2</sup> (range 2.5-20). Similar values have been found for mixed Ecklonia-Laminaria beds in South Africa (Velimirov et al. 1977; see review in Mann 1982).

The biomass of understory vegetation also varies considerably (Table 4). For these plants, the data of Breda (1982) from two sites in central California are most indicative of possible seasonal variation at a single site: an order of magnitude in one year. However, these relatively long-term studies by Gerard (1976) and Breda (1982) were done in central California where, as discussed in Section 3.5, storm-related variability appears to be greater than in southern California. As for percentage cover (see Section 2.4), understory algal biomass is usually lower beneath than away from a giant kelp canopy (North 1971b, Aleem 1973) and, in the absence of a canopy, generally decreases with depth (Aleem 1973).

Few estimates of the biomass of sessile benthic invertebrates or fish have been made (Table 4), and none over long

periods of time. Miller and Geibel (1973) suggested that their relatively high fish estimates for central California versus those for southern California (Table 4) could be due to differences in sampling methods.

### 3.6.3. Primary Productivity

Macrocystis pyrifera is a large plant with a complex morphology and its primary productivity is difficult to measure. A variety of techniques, including field harvests (Clendenning 1971b), growth measurements (Gerard 1976), changes in oxygen content of forest water (McFarland and Prescott 1959, Jackson 1977), field measurements of radioactive carbon uptake (Towle and Pearse 1973), and extrapolations from laboratory measurements (Wheeler 1978) have been used to estimate the productivities in Table 5. No doubt some of the variability in Table 5 is the result of technique (suggested by the greater similarity of estimates using the same technique).

Again, because of the long-term nature of the study, Gerard's (1976) data are perhaps most representative of true productivity, even though she did not account for grazing, detrital, or dissolved organic matter losses (see Section 3.6.4 below). Based on frond addition and growth measurements, Gerard (1976) found monthly productivity to vary between 0.4 and 3.0 wet kg/m<sup>2</sup>, with an average of 23 wet kg/m<sup>2</sup>/yr. Using the conversion factors from Coon (1982) given in Table 5, this is equivalent to 2.8 kg dry wt., or 530 g C(carbon)/m<sup>2</sup>/yr. However, there is some disagreement between conversion factors for wet weight-carbon as Towle and Pearse (1973) use a factor of 0.036. With this higher value, Gerard's (1976) productivity is 828 g C/m<sup>2</sup>/yr. In either case, these values are within the range of the more productive marine macrophyte communities (Mann 1973, 1982). Macrocystis biomass can also turn over rapidly (productivity [23 wet kg/m<sup>2</sup>/yr]/biomass [3.5 wet kg/m<sup>2</sup>] = turnover of 6.6 times/yr).

Mann (1982, pp. 59 and 60) suggested that large kelps like Macrocystis should have a low P/B (productivity/biomass)

Table 5. Macrocystis pyrifera net primary productivity<sup>a</sup> (see text for discussion of technique).

Technique Location	Wet kg/m <sup>2</sup> /year <sup>b</sup>	Source
<u>Field Growth</u>		
Santa Barbara, California	22 <sup>c</sup>	Coon 1981
Monterey, California	23	Gerard 1976
Palos Verdes, California	30	Kirkwood 1977
Southern California	20	Clendenning 1971b
<u>Physiological Estimates</u>		
Paradise Cove, California	75-92	McFarland and Prescott 1959
Santa Barbara, California	97	Wheeler 1978
San Diego, California	152	Jackson 1977
Monterey, California	109	Towle and Pearse 1973
<u>Harvest Estimates</u>		
Southern California	1.5	Clendenning 1971b
Santa Barbara, California	2.7	Coon unpubl. data

<sup>a</sup>Based on Coon 1982; net primary productivity = gross primary production - respiration.

<sup>b</sup>For rough conversions to other units, dry wt. = 0.12 wet wt. (Coon 1982), gC(carbon) = (0.023) g wet wt. (Coon 1982).

<sup>c</sup>Based on biomass of 7 wet kg/m<sup>2</sup>.

ratio because, relative to plants like Laminaria, Macrocystis diverts large amounts of energy to respiration and structural repair. We are unaware of any data that show this diversion is greater in plants like Macrocystis, and Gerard's (1976) data discussed above show that this P/B ratio can be similar to ratios given for Laminaria (Mann 1982). Thus, Mann's (1982) suggestion that the net production of kelp beds is greater than kelp forests is probably incorrect.

Heine (1983) measured the in situ productivity of two common understory red algae, Botryocladia pseudodichotoma and Rhodomenia californica, in the Point Cabrillo kelp forest in central California. However, rates were expressed

per gram dry weight of tissue and measured over small time intervals so yearly production per unit area of bottom cannot be calculated. We thus have no estimates of yearly understory algal production for giant kelp forests.

The summary of productivity suggests that if total net macroalgal primary productivity (Macrocystis plus all understory algae) is ever measured in a densely vegetated giant kelp forest, it may be the highest of any marine community. This might be expected, because most of the biomass of giant kelp is near the surface where light is highest, and carbon fixed at the surface is translocated to parts of the plants at lower light intensities below (see Chapter



Table 5. Macrocystis pyrifera net primary productivity<sup>a</sup> (see text for discussion of technique).

Technique Location	Wet kg/m <sup>2</sup> /year <sup>b</sup>	Source
<u>Field Growth</u>		
Santa Barbara, California	22 <sup>c</sup>	Coon 1981
Monterey, California	23	Gerard 1976
Palos Verdes, California	30	Kirkwood 1977
Southern California	20	Clendenning 1971b
<u>Physiological Estimates</u>		
Paradise Cove, California	75-92	McFarland and Prescott 1959
Santa Barbara, California	97	Wheeler 1978
San Diego, California	152	Jackson 1977
Monterey, California	109	Towle and Pearse 1973
<u>Harvest Estimates</u>		
Southern California	1.5	Clendenning 1971b
Santa Barbara, California	2.7	Coon unpubl. data

<sup>a</sup>Based on Coon 1982; net primary productivity = gross primary production - respiration.

<sup>b</sup>For rough conversions to other units, dry wt. = 0.12 wet wt. (Coon 1982), gC(carbon) = (0.023) g wet wt. (Coon 1982).

<sup>c</sup>Based on biomass of 7 wet kg/m<sup>2</sup>.

ratio because, relative to plants like Laminaria, Macrocystis diverts large amounts of energy to respiration and structural repair. We are unaware of any data that show this diversion is greater in plants like Macrocystis, and Gerard's (1976) data discussed above show that this P/B ratio can be similar to ratios given for Laminaria (Mann 1982). Thus, Mann's (1982) suggestion that the net production of kelp beds is greater than kelp forests is probably incorrect.

Heine (1983) measured the in situ productivity of two common understory red algae, Botryocladia pseudodichotoma and Rhodomenia californica, in the Point Cabrillo kelp forest in central California. However, rates were expressed

per gram dry weight of tissue and measured over small time intervals so yearly production per unit area of bottom cannot be calculated. We thus have no estimates of yearly understory algal production for giant kelp forests.

The summary of productivity suggests that if total net macroalgal primary productivity (Macrocystis plus all understory algae) is ever measured in a densely vegetated giant kelp forest, it may be the highest of any marine community. This might be expected, because most of the biomass of giant kelp is near the surface where light is highest, and carbon fixed at the surface is translocated to parts of the plants at lower light intensities below (see Chapter

4, Section 4.3.2.1). Nutrients needed for growth are also frequently high in the nearshore waters where these plants occur (see Chapter 2, Section 2.5). Finally, the community is always submerged in waters of near-constant salinity. Thus, unlike other productive communities such as estuarine sea grass beds or mangrove forests, plants in the kelp forest have relatively little non-photosynthetic support tissue and do not use much of the energy produced for osmoregulation to adapt to periodic emergence-submergence.

The final source of primary production in giant kelp forests is phytoplankton. To our knowledge, phytoplankton production within a forest has never been estimated. Evidence from other studies, however, suggests it is small relative to the seaweeds. Platt (1971) estimated phytoplankton production at about 200 g C/m<sup>2</sup>/yr in a bay in Nova Scotia, where the *Laminaria* beds averaged about 1500 g C/m<sup>2</sup>/yr (Mann 1973). Clendenning's (1971b) estimates for phytoplankton production in southern California coastal waters are similar. Shading no doubt would reduce these values under a surface canopy. Phytoplankton production, at least around areas of kelp, is low compared to the macroalgae, but is in the range of values given by Ryther (1969) as typical of phytoplankton in nutrient-rich upwelling areas unshaded by a surface seaweed canopy.

#### 3.6.4 Energy Flow - Food Webs

The net primary production of seaweeds in a kelp forest is available to consumers in three forms: (1) living tissue on attached plants, (2) drift in the form of whole plants or detached pieces, and (3) dissolved organic matter exuded by attached and drifting plants. Detritus is very small pieces of drift algae, and particulate organic matter (POM) is even smaller pieces. Both these subcategories may be derived from attached plants or from the breakdown of drift. The fate of these forms, plus within-forest phytoplankton production and imported sources of energy (plankton and drift seaweed from other areas), is illustrated in the generalized kelp forest food web of Figure 11.

Gerard (1976) determined the general disposition of *Macrocystis* productivity (attached plants and drift) in the Point Cabrillo kelp forest. She estimated that of the yearly production (excluding grazing, detritus, and dissolved organic matter losses from attached plants), 70% entered the consumer assemblage as drift. Of this, an estimated 40% was utilized within the forest, and 50% was transported out. This latter figure is of interest as this exported production may end up on nearby shores where it is an important source of energy for beach invertebrates and, ultimately, for shore birds (Yaninek 1980, North 1971b; see Chapter 4, Section 4.6). Detached *Macrocystis* and other macroalgae may also drift offshore along the bottom where they presumably serve as food (North 1971b) and habitat (Cailliet and Lea 1977) for deep-water organisms living where light is insufficient for *in situ* photoautotrophic productivity. Plants may drift offshore on the surface as kelp rafts that provide habitat for juvenile and some adult fishes (Mitchell and Hunter 1970).

Gerard (1976) also estimated that only ~ 3%-6% of the total *Macrocystis* production was consumed directly by animals grazing on attached plants. Direct detrital loss was not measured, although it may be an important form of primary production entering the community, particularly from senescent fronds. Estimates of dissolved organic matter (DOM) produced by large seaweeds are highly variable, and may partly be an artifact of handling and laboratory technique (Fankboner and de Burgh 1977).

Little is known about the precise fate of drift algae in giant kelp forests, other than it can be eaten without decomposition by large herbivores like sea urchins and abalone (see Section 4.4.3). The experiments by Bedford and Moore (1984) in *Laminaria saccharina* beds in Scotland show that much of the drift is not decomposed by microbes but, instead, eaten by small detritivores (echinoderms, polychaetes, and amphipods). Decomposition by microbes increased when these detritivores (that would otherwise crop rotting tissue or repeatedly remove healthy tissue preventing microbial colonization) were excluded. In contrast

GENERALIZED FOOD WEB FOR A MACROCYSTIS PYRIFERA FOREST

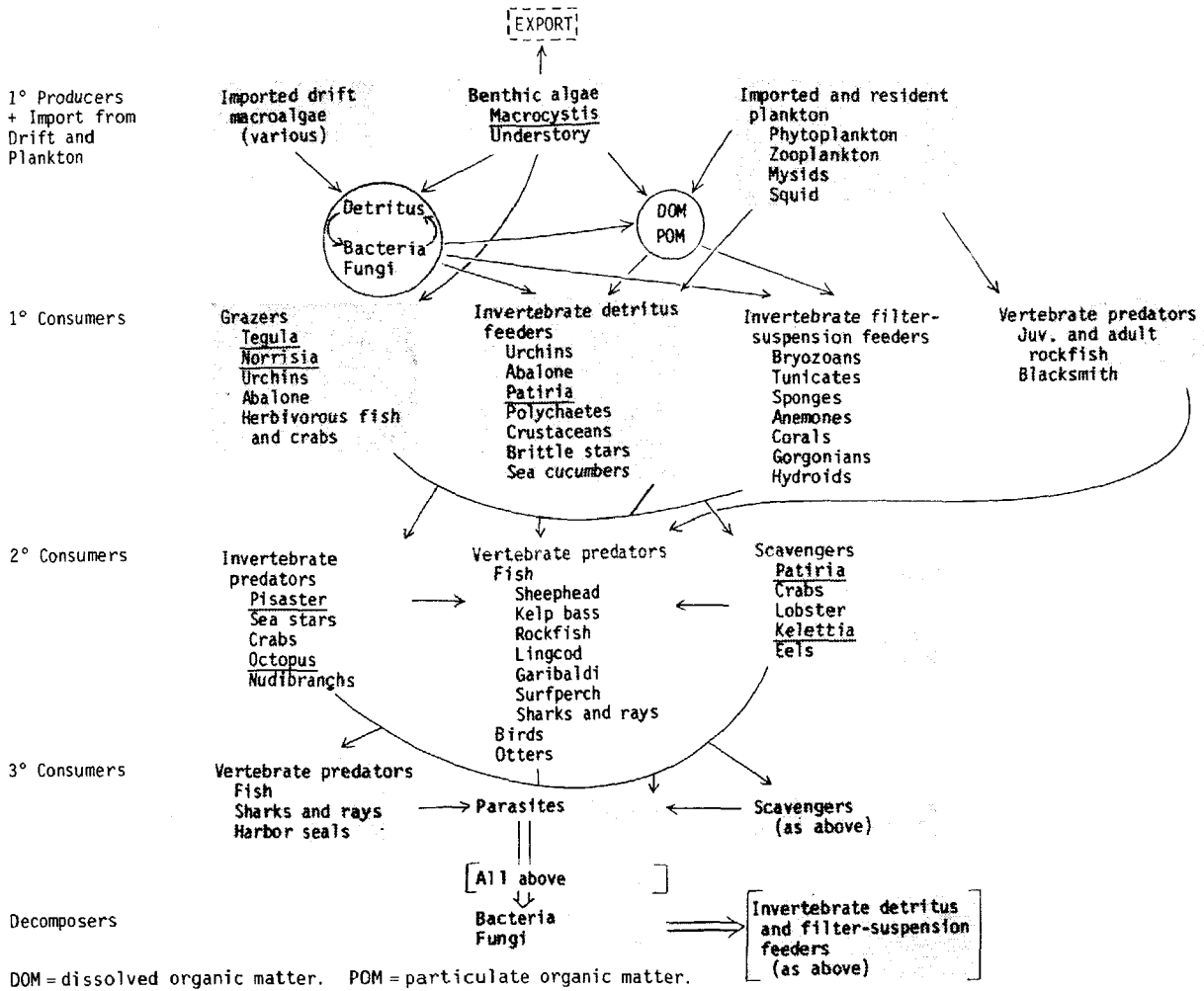

Figure 11. A generalized food web for a kelp forest. Arrows indicate the direction of energy flow.

to vascular plants, Bedford and Moore (1984) point out that drift seaweeds have few structural polysaccharides, lack waxy coverings, and may exude fewer protective chemicals, making them more directly palatable to detritivores. This suggests that the fate of subtidal algal drift (directly to detritivores) may be fundamentally different from that of vascular plant detritus (through microbes to detritivores). Furthermore, this difference may be ultimately reflected in the high abundances of fish in kelp forests; many of these fish feed on small crustaceans and polychaetes that are

probably detritivores (see Sections 4.4.2.8 and 4.5).

Our understanding of energy flow through the remainder of the giant kelp forest community is based largely on feeding observations, with few quantitative studies. Rosenthal et al. (1974) constructed a food web from feeding observations in a kelp stand near Del Mar which, with additions from observations made in other areas, is summarized in the generalized giant kelp forest food web of Figure 11. As might be expected from the variety of ways energy can enter the

consumer assemblage and the number of different species in the assemblage, feeding relationships can be complex. All of the pathways shown have been verified by feeding observations or gut content studies, and in addition, Fankboner (1976) and Fankboner and Druehl (1976) have shown that at least two invertebrates can use dissolved organic matter produced by Macrocystis integrifolia.

Biomass, densities, and feeding observations have been used by Pearse and Hines (1976) to construct a semi-quantitative food web for the Point Cabrillo kelp forest that shows standing stocks and feeding relationships (Figure 12).

In our view, productivity and energy flow in communities are a consequence, not a cause, of population and community structure. As a subdiscipline of ecology they may be of interest in their own right, but they have contributed little to our understanding of community structure and dynamics. Moreover, food webs constructed from energy flow studies can be misleading as they may be interpreted as "control webs"; because A eats B, A controls the population's size and/or distribution of B. Such a misinterpretation of food webs has, no doubt, contributed to the popular notion (probably misconception -- see Ehrlich and Birch 1967, Connell and Sousa 1983, Wiens 1984) that "nature is in balance."

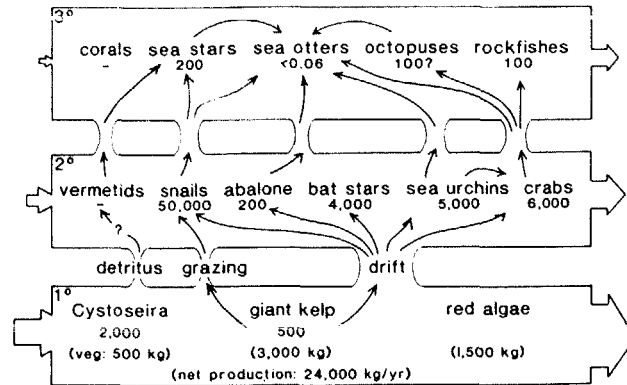

Figure 12. A food web for the Point Cabrillo kelp forest near Monterey. Numbers give approximate number of organisms/1000 m<sup>2</sup>. Numbers in parentheses give approximate wet weight/1000 m<sup>2</sup> (from Pearse and Hines 1976).

Populations may be regulated by predators or grazers, but they can also be regulated by a variety of other processes. Figure 13 illustrates some of the "control" possibilities discussed in detail elsewhere in this profile (see especially Chapters 2 and 5), many of which are not easily measured in equivalent energy units (e.g., a storm removing a large quantity of kelp or killing sea urchins), or affect such small amounts of energy that they are not usually considered in even a detailed energy flow analysis (e.g., spore or larval removal by filter feeders).



## CHAPTER 4

### NATURAL HISTORY AND ECOLOGY OF KELP FOREST ORGANISMS

*The number of living creatures of all Orders whose existence intimately depends on the kelp is wonderful. Darwin (1860).*

#### 4.1 INTRODUCTION

This chapter discusses most of the common species of algae, invertebrates, fish, birds, and mammals that frequent Macrocystis forests or are an integral part of them along the west coast of North America. Where relevant, we also include comparisons with other regions of the world. This chapter is not meant to provide comprehensive species checklists of the organisms which may occur in kelp forests; these may be obtained from other sources referred to in the appropriate sections below. Rather, we discuss the natural history of many species and how they may function in, or contribute to, the structure of kelp forests in particular localities. We divide the ubiquitous and diverse benthic invertebrates and seaweeds into functional categories, grouping species which we subjectively judge to have similar effects on the other species present. These categories are then separated into taxonomic groups. Plankton and decomposers and diseases are treated in separate sections, as are fish, birds, and mammals.

#### 4.2 PLANKTON AND DECOMPOSERS

As might be expected given the diversity of large plants and animals in giant kelp forests, attention has focused on these, and relatively little is known about the small plants and animals that

constitute the planktonic assemblage in the water. Clendenning (1971a) gave a brief list of phytoplankton from the La Jolla kelp forest, and Miller and Geibel (1973) discussed the seasonal abundance of various plankton groups (especially zooplankton) in the kelp forest at Point Cabrillo near Monterey, California. Additional studies have examined zooplankton in relation to fish feeding (Hobson and Chess 1976, Bray 1981, Bray et al. 1981) or migratory behavior (Hobson and Chess 1976, Hammer and Zimmerman 1979, Hammer 1981). There are no complete identification guides. Cupp (1943) is still the best available guide to the diatoms, and the text by Newell and Newell (1963) is useful for identifying the more common phyto- and zooplankton. Parsons et al. (1977) reviewed planktonic organisms and the oceanographic processes that affect them, and provide an excellent bibliography.

As shown in Figure 11, plankton may be produced in the kelp forest or imported (primarily from offshore). With the exception of some mysids (discussed below), few entirely planktonic organisms (holoplankton) appear to be residents of kelp forests; most are probably imported. The kelp forest community produces plankton in three general categories: meroplankton--the spores, larvae, or detached individuals (e.g., benthic diatoms) of benthic organisms; demersal zooplankton -- primarily small crustaceans

that migrate between the benthos and the water column above; and mysids that may be in both of these categories as well as being holoplanktonic.

Even less is known about bacteria and fungi that decompose organic matter within kelp forests. These organisms and the materials they produce and degrade are probably important sources of food for the largely detritus-based food web, but perhaps less important than direct consumption of drift algae by detritivores (see Section 3.6.4). General characteristics of surface bacteria and decomposition by bacteria and fungi are briefly discussed by Scotten (1971) and ZoBell (1971).

General composition and natural history of the more abundant kelp forest plankton are discussed below.

#### 4.2.1 Phytoplankton

Probably all species of phytoplankton found in nearshore waters could be found in kelp forests at some time and there appear to be no species endemic to kelp forests. Clendenning (1971a) listed 58 species of diatoms and dinoflagellates collected from the La Jolla kelp forest in June 1958, with the diatom Leptocylindricus spp. and the dinoflagellate Diplopeltopsis minor most abundant. Miller and Geibel (1973) did not identify phytoplankton to the species level in their study of the Point Cabrillo kelp forest, but they stated that the diatom genera Coscinodiscus and Rhizosolenia were most commonly observed.

Various species of benthic diatoms are also found in the plankton, particularly after storms when individuals or "chains" have been dislodged by water motion. The most common species are Licmophora abbreviata, Meloseira moniliformis, and the large, angular Isthmia nervosa (Figure 14). The former is particularly common on giant kelp blades. When attached, these and other benthic species often form soft, hair-like coverings on senescent macroalgae, attached understory plants, and unoccupied hard substrata if light intensity is high. If the water is calm and light is high for long periods, other diatoms may form thin

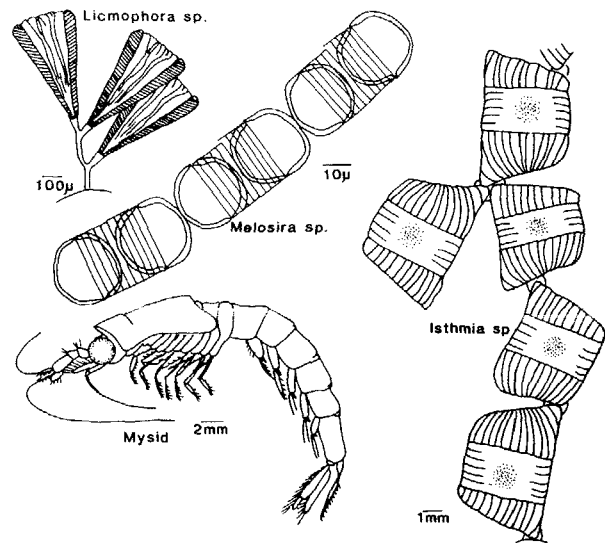

Figure 14. Common benthic diatoms and a mysid shrimp.

brown films or even thick mats on patches of soft substrata within a kelp forest. We commonly observe late spring "blooms" of benthic diatoms on understory articulated corallines in Carmel Bay, California, when the overstory canopies of Pterygophora californica and Macrocystis pyrifera are still reduced from winter storms. When connected in long chains or in a common mucilagenous sheath, these diatoms may be confused with small, filamentous brown algae whose external form can be similar.

Planktonic and benthic diatoms are consumed by filter feeders and grazers, but little is known about consumption rates or consumer feeding preferences in kelp forests. Trotter and Webster (1984) have shown that free-living nematodes associated with Macrocystis integrifolia eat bacteria and diatoms, and that particular species of nematodes may prefer one food source or the other, and may also prefer particular species of diatoms.

Dinoflagellates may become extremely abundant in kelp forests during red tides (up to  $20 \times 10^6$  cells/liter; Holmes et al. 1967). An extensive nearshore bloom of Ceratium sp. occurred in the vicinity of Monterey, California in August and

September 1980 (Foster and Heine 1981). When water containing this bloom moved into the kelp forests, visibility was reduced to zero on the bottom. Whether or not they produce a bloom, some dinoflagellate species are toxic to man. As dinoflagellates are usually most abundant in summer and early autumn, harvesting of filter feeding shellfish (particularly mussels) that may concentrate dinoflagellates is banned during this period.

Phytoplankton reduce water clarity and therefore contribute to the reduction of light within kelp forests (see Chapter 2). Because phytoplankton growth is often stimulated by increased nutrients, these organisms may be particularly abundant around sewer outfalls (Eppley et al. 1972, Kleppel et al. 1982), and along with increased turbidity from suspended solids, can affect macroalgal populations by reducing light. Reduced light associated with the Los Angeles sewer discharge at White Point may have contributed to the loss of kelp forests at Palos Verdes (Wilson 1982).

#### 4.2.2. Zooplankton

Almost all nearshore zooplankton species can also be found in kelp forests at various times. Holoplanktonic species can be an important source of food for some kelp forest fishes (particularly the blacksmith; Bray 1981; see Section 4.5 below), and are imported as energy and nutrients into the kelp forest from planktonic communities as fish feces (Bray et al. 1981). Zooplankton may occasionally have dramatic effects on kelp forests. Duggins (1981a) described a reduction in sea urchin grazing on macroalgae in Alaska caused by an increase in benthic diatoms and an influx of pelagic salps. The sea urchins temporarily fed on the diatoms and salps, grazing on macroalgae decreased, and macroalgal abundance increased.

One group of zooplankton, the mysids or opossum shrimp (Figure 14) are usually associated with kelp forests, and can form extremely dense, migrating swarms on the bottom or under the Macrocystis surface canopy (Clarke 1971). Individuals may be up to 2 cm long, and swarms may be

extensive (meters thick and wide) and so dense as to obscure the bottom completely. Mysids apparently feed on both small plankton and macroalgal detritus, and are fed upon by many kelp forest fishes (Clarke 1971), and even gray whales (see Section 4.6.2.3 below).

In addition to the above zooplankton, there is an assemblage of primarily small crustaceans that migrate at night from the bottom up into the water column (Hobson and Chess 1976, Hammer and Zimmerman 1979, Hammer 1981). These demersal zooplankton often use bottom cover algae as habitat during the day, and at Catalina Island at least, are fed upon in the plankton at night by a variety of fishes (Hobson and Chess 1976).

### 4.3 MACROSCOPIC PLANTS

#### 4.3.1 Introduction

The west coast of North America is unique in the number of subtidal algal species that form canopies extending to the surface of the sea, and perhaps with the exception of Australia, in the number of species which form an understory canopy 1-2 m high. Most of these are Laminariales of the families Alariaceae, Laminariaceae, and Lessoniaceae (Druehl 1970). The distribution of surface canopy species is discussed in Chapter 3, along with depth-distribution patterns.

Within any kelp forest, the vertical stratification of canopy levels in the water column is an obvious feature to any observer. The density of the vegetation layers may have several effects in a kelp forest. The biomass and vertical structuring they form provide a nursery and protective cover for many species of fish (Quast 1971a). These layers may sequentially reduce the light that reaches primary substratum to < 1% of surface, a reduction that may affect the recruitment and growth of algal species (see Chapter 2). Water motion may also be altered within dense stands by the kelp themselves (see Section 2.6). The result of interactions of environmental and biotic factors is, therefore, quite complex. While the presence of recruits of a species and subsequent growth rates and survival may be directly related to



features of the environment (see Chapters 2 and 5), plants may also change these features as they grow and spread vertically through the water column.

Following Foster (1975a), we have divided the kelp forest vegetation functionally into four layers above the primary substratum (Figures 3 and 6): encrusting species, filamentous and foliose species, understory Laminariales and Fucales, and the species forming surface canopies. Each of these levels will have an effect on the recruitment, growth and survival of species below, and because all start life on the bottom, on themselves. Complete descriptions of California seaweeds, including geography and depth distributions, can be found in the taxonomic work by Abbott and Hollenberg (1976), and the biology and natural history of the most abundant species in Dawson and Foster (1982). The more common species are discussed below.

#### 4.3.2 Species That Form Surface Canopies: Kelp Forests

4.3.2.1 Macrocystis. The morphology and typical Laminariales life history of Macrocystis is outlined in Chapter 1 (see Figure 1). To grow into mature sporophytes, microscopic spores must alight on suitable substratum, develop into gametophytes, become fertilized, then grow from a microscopic sporophyte through the water column to the surface of the sea. The hazards encountered during the course of this development are numerous (see Chapter 5), and it is not surprising that few, if any, of the billions of spores produced by a single mature plant ever make it through all of these stages. Sedimentation, the pre-emption of space by other species, the lack of light and shading effects of other species, nutrient limitation, and the effects of various small and large grazers are some of the factors which affect the growth and survival of plants.

Macrocystis and the other large kelps, by virtue of their high growth rates and sizes, are able to modify their circumstances to a much greater degree than smaller seaweeds. It is true to some extent for any species that the devastating effects of many factors may be

outgrown. For example, a relatively small amount of sediment on the substratum may prevent the attachment of algal spores, and may also remove over 98% of the incident irradiance from reaching the substratum (Devlinny and Volse 1978, Norton 1978). Once a plant survives to a juvenile stage of even a few millimeters height, however, the effect of fine sediment may be greatly reduced. The larger members of the Laminariales and Fucales can take advantage of the progressively increasing light levels as they grow through the water column. This involves an increase in the spectra of light available as well as the intensity (Wheeler 1980a, Luning 1981). Blades that lie near the surface of the sea may take better advantage of sunlight, minimizing the absorptive effects from sea water or other species of algae. In the case of Macrocystis, this is borne out by the fact that most of the biomass is concentrated at the surface in the upper 20%-30% of the plant where most of the photosynthesis occurs (Lobban 1978; Plates 1A, 1B). North (1972b) found that this concentration of biomass at the surface occurs regardless of water depth. Translocation through phloem-like sieve tubes moves fixed carbon (primarily mannitol), and proteins down surface fronds to the holdfast and short, understory fronds (Parker 1971, Lobban 1978).

The early growth of Macrocystis pyrifera in southern California has been described by Neushul and Haxo (1963), North (1971a), and Dean et al. (1983). Giant kelp fronds may elongate at a rate of over 30 cm/day, making it one of the fastest-growing plants known (North 1971c). Neushul (1963) estimated that it took 14 months from sporulation to maturity for plants in southern California. Plants may live up to 8 years (North 1971a, Rosenthal et al. 1974). Rosenthal et al. (1974) recorded the survivorship of a cohort of Macrocystis pyrifera plants in the Del Mar kelp forest, over a period of 3.5 years (Figure 15). They found that there was a high mortality rate in the first few months after recruitment, but that this decreased when plants were a year old. Five out of the original cohort of 156 plants survived after one year. Dayton et al. (1984) constructed a life table for a Macrocystis

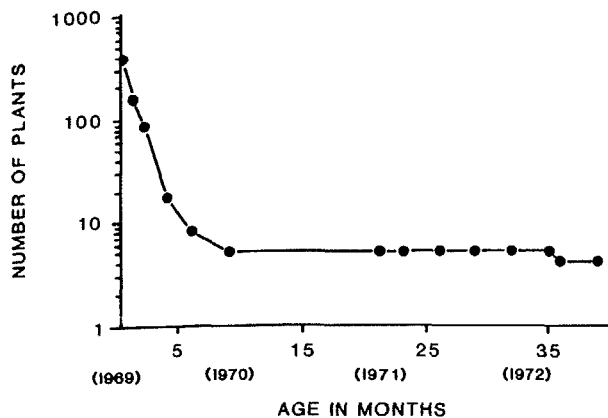

Figure 15. A survivorship curve for individually-tagged Macrocyctis pyrifera plants that recruited to a kelp forest off Del Mar, California in September 1969. The original cohort was 387 plants (re-drawn from Rosenthal et al. 1974).

population at a depth of 15 m in the Point Loma kelp forest. They found that only 19% of plants survived the first three months after recruitment, and 2% after nine months. Some plants survived to an age of 7 years. The life span of fronds, however, is only about 6 months (North 1971b).

Kain (1982) compared the short-term growth rates of fronds of Macrocyctis pyrifera from three sites in southern New Zealand with those at a site in southern California. The relative growth rates of stipes and laminae from the different populations were similar. By a series of morphometric measurements, however, Kain (1982) determined that plants from the most exposed site in New Zealand more closely resembled those in California than those in the other populations in New Zealand.

As Macrocyctis plants grow through the water column, they have fewer shading interactions with progressively fewer species. Pearse and Hines (1979) found, for example, that many species of large brown algae recruited into an area near Santa Cruz, California recently cleared of sea urchins. Macrocyctis recruited at

4-5/m<sup>2</sup>, Laminaria setchellii at 4-12/m<sup>2</sup>, Pterygophora californica at 4-6/m<sup>2</sup>, Nereocystis at 1-2/m<sup>2</sup>, and Cystoseira at 1/m<sup>2</sup>. Macrocyctis eventually grew to the surface, forming a canopy, while the species that were shaded below declined in abundance.

If effects among species decrease in importance once plants reach the surface canopy, intraspecific events must assume more importance. Dense stands, about 4 plants/10 m<sup>2</sup>, provide a "forest" effect, with deep shading beneath the canopy (see cover photo). Darwin (1860) remarked on the calming effect which dense stands of Macrocyctis have on turbulent inshore waters. This reduced flow can also affect carbon assimilation and nutrient uptake (see Section 2.6). At the other extreme of density, solitary plants do not usually fare well. They may be ravaged by herbivorous fishes, especially halfmoon and opaleye, which appear to be attracted in numbers to isolated plants (North and Hubbs 1968, LOSL 1983). Because the frond meristem is at the tip, it is easily damaged by fish grazing, and once destroyed, frond growth stops. These plants may also be more susceptible to the effects of severe water motion without the dampening effect of nearby plants. Between these extremes, the effects of density on Macrocyctis are equivocal. North's (1971b) observation of plants at three densities showed that those in the densest stands (some 15 stipes/m<sup>2</sup>, and 7 stipes/m<sup>2</sup>) could grow faster than those at 1/m<sup>2</sup>. He attributed this difference to some unknown localized factor affecting growth. Neushul and Harger (in press) planted adult Macrocyctis plants at different densities and found that, over a period of one year, the number of fronds per plant increased for plants growing at low density, stayed about the same for those at the medium density, and decreased for those at high density. These differences were also reflected in the weights of plants, with those at the highest density weighing the least (see also Section 5.5.2).

The effects of density on algal growth are far from resolved, however, and may be of some importance to the dynamic relationships of plants in kelp communities (c.f. Schiel and Choat 1980).

It remains unclear whether sites which naturally feature dense stands of kelp are simply environmentally favorable, while sites with fewer plants reflect less favorable conditions. The alternative is that the density of the plants themselves modifies the site. Of course, both of these are possibilities in particular circumstances, but they are relevant to attempts at establishing kelp in areas where it is now absent.

4.3.2.2 Other species that form surface canopies in California and Mexico. Nereocystis luetkeana (Figure 3) may occur in both pure and mixed stands with Macrocystis in that area of California where their ranges overlap (Yellin et al. 1977). Most of the work on this species, however, has been done north of Santa Cruz, California, where it is the dominant kelp which forms a surface canopy. This species is an annual, and may form dense stands to a depth of ~ 12 m in central California (Foster 1982a). Nereocystis usually occurs in more turbulent water than Macrocystis, and Foster (1982a) and Van Blaricom (in press) suggested from their observations that bull kelp populations may also be less affected by sea urchin grazing.

Duggins (1980) found that when dense aggregations of sea urchins were removed in Torch Bay, Alaska, a dense stand of Nereocystis quickly recruited. This species is an annual, however, and was eventually replaced by perennial laminarians. Nevertheless, dense stands of Nereocystis occur year after year in large areas of inshore waters, indicating its ability to maintain space through reseeding areas occupied by adult plants (Duggins 1980, Foster 1982a).

Inshore areas from the low intertidal to a few meters depth are often inhabited by dense stands of Egregia menziesii (Figure 3), a species that can overlap in depth distribution with Macrocystis integrifolia, but does not usually extend into deep enough waters to affect the abundance or distribution of M. pyrifera. Black (1974) did a demographic study of E. menziesii in the intertidal zone near Santa Barbara, from recruitment to senescence. He found that the grazing activities and the scars formed by the

limpet Notoacmea insessa were a major cause of frond breakage, and that the life histories of these two species were intimately associated (Black 1974).

The outer edges of some kelp forests in southern California are inhabited by the elk kelp Pelagophycus porra (Figure 3, Plate 1D). Because it occurs in deep water (18+ m) and is not generally abundant, there is little known of its biology. In a recent study, Hart (1982) found that stipe elongation was density-dependent. Plants in a 10 m<sup>2</sup> area at 1.4/m<sup>2</sup> grew significantly faster than those in a 10 m<sup>2</sup> area at 0.25 plants/m<sup>2</sup>. Plant blades were significantly larger, however, in the less dense stand. Studies by Parker and Bleck (1966) and Coyer and Zaugg-Haglund (1982) indicate that this species is an annual.

Pelagophycus may be found at depths to 30 m. Haptera are usually attached to rock, but may spread to sand and gravel. A population at Big Fisherman's Cove, Catalina Island grows entirely on a sand substratum. Stipes may reach lengths of 27 m, while the blades of mature sporophytes may be up to 20 m long and a meter broad (Abbott and Hollenberg 1976). This species may have been more abundant in the past; drifting plants were commonly used as a navigational aid to Spanish and Portuguese mariners in the 1600's, signalling a change in a ship's course before land was sighted (Dawson and Foster 1982).

Cystoseira osmundacea (Figure 1) is a perennial species in the Fucales that cohabits inshore areas with Macrocystis plants. A study in the Point Cabrillo, Monterey kelp forest (Schiel in press a) showed that single plants 6-9 m deep could have 30+ fronds extending to the surface. Although the plants are perennial, the reproductive tissues and vegetative structures which accompany them are highly seasonal, appearing at the surface of the sea between June and September. After reproduction, these structures deteriorate and break away, leaving the holdfast and larger basal blades. In mid-summer densities of 9 plants/m<sup>2</sup> may produce an estimated 20% of the surface canopy in a forest shared with Macrocystis. Cystoseira osmundacea is depth-restricted,

however, in its abundance and in the sizes of plants. Below depths of ~ 10 m, plant numbers become lower, and a decreasing proportion have thalli that extend more than a few meters from the bottom. This sort of depth distribution is similar to that found for most of the abundant Fucales found in austral areas (Schiel 1981, Choat and Schiel 1982).

Sargassum muticum is another Fucales that co-occurs with Macrocystis in some areas of southern California, especially Catalina Island. An experiment by Ambrose and Nelson (1982) at Santa Catalina Island indicated that a dense recruitment of S. muticum can preempt the space for other species to settle and grow, and this species may be able to keep Macrocystis from localized sites.

Sargassum muticum has caused some excitement since its accidental introduction and dramatic spread along the west coast of North America, and its recent arrival on the south coast of England (Fletcher and Fletcher 1975, Norton 1977). Deysher and Norton (1982) found experimentally that the majority of recruits appeared within 2-3 m of parent plants, although some recruits could be found at distances to 30 m. It was proposed that this species may have spread long distances by detachment of vegetative fronds which continue to grow and develop while adrift and swept along by wind and currents (Deysher and Norton 1982). As this species is monoecious and self-fertile, populations could become established at considerable distances by propagules dispersed from one adult plant.

4.3.2.3 Surface canopy species in other areas. Alaria fistulosa is a large kelp that is particularly abundant in Alaska. This species has a short stipe with sporophylls concentrated near the bottom of each plant. The vegetative blade, however, has a gas-filled mid-rib, and may reach a length of 25 m and a width of 2 m. At most localities, this species is largely confined to depths of < 5 m. Dayton (1975) did selective canopy removals of A. fistulosa, species of Laminaria and Agarum cribosum at a site near Amchitka Island, Alaska. He found that when Laminaria spp. were removed from quadrats at 5-m depths, the quadrats were

colonized by Alaria, but that this species did not invade other quadrats where the Laminaria canopy was left intact. At depths of 9.1 m and 16.8 m, Alaria colonized only the quadrats from which both Laminaria and Agarum were removed. As few Alaria were found naturally at these depths, Dayton (1975) concluded that this is a fugitive species, which may take advantage of free space but which is normally prevented from doing so by the presence of other species. He concluded that the lower distribution of Alaria appeared to be restricted primarily by the grazing activities of sea urchins.

#### 4.3.3 Understory Canopy Species: Kelp Beds

4.3.3.1 Species in California and Mexico. Many members of the Laminariales and Fucales form a canopy 0.5 to 2.5 m off the bottom, and dense stands of single species may completely or partially exclude other species of large brown algae (see Section 2.4). Pterygophora californica (Figure 3, Plate 1E) is a perennial species abundant along the west coast (Abbott and Hollenberg 1976). This species can grow to maturity in 6 months in central California (Foster pers. obs.). At sites in Stillwater Cove, Carmel Bay, sporophylls and terminal blades may be almost entirely removed during periods of intense water motion in winter. New growth of fronds occurs in spring and, by summer, frond growth is great enough that plants at 4-8/m<sup>2</sup> can form a closed canopy over the substratum. This species has been transplanted to the Pendleton Artificial Reef near San Onofre in southern California (LOSL 1983). It was believed to be more resistant to fish grazing (thicker blades, meristem at base of blade) than Macrocystis, and that it would modify the populations of encrusting organisms prevalent on the reef so that other brown algae might naturally establish. Storms and fish grazing, however, removed almost all blades after transplantation (LOSL 1983).

Growth rings and sporophyll scars have been used to estimate the age of individual plants thought to live over 15 years (Frye 1918). Although Frye's data are indecipherable, field studies by DeWreede (1984) and Reed and Foster (pers.

obs.) now suggest that growth rings are annual. Maximum ages for Pterygophora plants have been estimated to be 18 years in central California (Reed and Foster 1984), 11 years in southern California (Dayton et al. 1984), and 10 years in British Columbia (DeWreede 1984).

All of the understory kelp species have been described morphologically, but little is known about most of them from field studies on the west coast. Each may form dense aggregations locally, but their individual effects on the remainder of the community are generally not known. Some of these species can have a fairly long (80+ cm), erect stipe, placing the blades and canopy over a meter above the substratum (for example, Laminaria setchellii [Figure 3], Pterygophora californica, and Eisenia arborea [Figure 3]). Many others have short stipes and long blades. This type of morphology results in plants being draped over the substratum and flopping back and forth with water motion. Laminaria farlowii, Agarum fimbriatum, and Costaria costata are examples. Besides shading substrata near plants, abrasion by blades could also have local effects. Dayton et al. (1984) calculated life tables for some understory species in southern California. They estimated that Eisenia arborea plants can live for 11 years and Laminaria farlowii for 6 years. By selectively removing the understory kelps, they found that the stipitate species (Eisenia, L. setchellii and Pterygophora) inhibited the successful recruitment of Macrocystis, Pterygophora, Nereocystis, and Desmarestia.

Extreme water motion may be the primary cause of adult Pterygophora californica mortality in central California, as drift plants are commonly observed on beaches after storms. At more protected locations such as Stillwater Cove (see Section 3.3.1) other factors such as occasional damage to the meristem by turban snails (Section 4.4.3.2), or destruction of the medulla in the stipe by burrowing amphipods (Foster pers. obs.) may cause a slow attrition of old individuals.

#### 4.3.3.2 Species in other areas.

There has been extensive research on the biology of Laminariales in many areas of

the world. We will not review that work here, but will mention a few species that have either been well-studied in the field, or whose effects on other species have been demonstrated. Kain (1979) provides a review of the biology and field research on Laminaria and related species.

Various species of Laminaria and Agarum have been studied in northern areas of the eastern Pacific. Demographic studies on these species are lacking, but some studies have selectively removed canopies or have prevented sea urchins from access to areas of substratum. Paine and Vadas (1969) reported that Nereocystis became the dominant alga in the first year on subtidal rocks kept free of sea urchins, forming some 90% of the biomass. In the following year, L. groenlandica became the dominant alga.

Dayton (1975) worked with three species of Laminaria and Agarum cribosum in Alaska. Laminaria longipes was able to re-establish in areas after its canopy was removed. It has a rhizome-like holdfast with multiple meristems, and can quickly regrow stipes and fronds after they are removed. When the canopies of three laminarian species, L. groenlandica, L. dentigera, and L. yezoensis, were removed in a shallow site, the percentage cover and density of Agarum increased. The long-term consequences of these invasions were not known.

Duggins (1980) removed Laminaria groenlandica from several small plots in Torch Bay, Alaska. In the first year after removal, there was a high recruitment of annual kelp. By the second year, however, Laminaria was once again dominant (mean  $\pm$  S.D.:  $53 \pm 27$  plants/m<sup>2</sup> vs.  $8 \pm 7$ /m<sup>2</sup> for other species). There was no successful recruitment of any species in the control plot where the canopy was left intact.

Understory Laminariales and Fucales are very abundant in many other boreal and temperate areas of the world. In northern New Zealand, for example, Fucales are usually dominant in shallow subtidal areas (< 5 m depth), while a single kelp, Ecklonia radiata, dominates deeper areas. In most cases, the substratum beneath dense stands of these algae is covered

with encrusting red algae (Choat and Schiel 1982). Removal of the dominant canopies of one species often allows the invasion of another species. The result depends partially on the season of the year in which canopies are removed, as the peaks of fertility for individual species are different (Schiel 1981).

Nova Scotia is another area which has had large research programs in kelp bed ecology. The perennial alga Laminaria longicruris, may form extensive stands from shallow depths to below 20 m (Mann 1972a). The extent of many of these stands has been altered by sea urchins (Strongylocentrotus droebachiensis) in recent years (Breen and Mann 1976). The biology and growth of L. longicruris have been extensively studied. The growth rates of this species can be limited during part of the year by low nutrient availability (Chapman and Craigie 1977). Gerard and Mann (1979) found that the morphology of plants was influenced by the intensity of water motion, and was different at exposed and sheltered sites. Growth in the exposed population was lower than in the sheltered one during 8 months of the year due to low nutrient and light levels. Gagne et al. (1982) reported that the potentially limiting factors of light and nutrients had different levels at various sites. Growth rates of plants may therefore be different at these sites. Where nutrients are plentiful, maximum growth can occur during summer when light levels are high. In nutrient-limited areas, plants tend to concentrate their growth during winter when nutrient levels are higher.

Chapman (1984) examined the reproduction, recruitment and mortality of Laminaria longicruris and Laminaria digitata in a series of innovative experiments. By measuring sorus area and microscopically examining sorus tissue, he estimated the number of spores produced by plants of both species. The recruitment rate of each species was estimated by placing ceramic bricks beneath each canopy during each month of one year. At the end of each month, bricks were brought into the laboratory and placed under lights in running seawater until plants were visible. Natural recruitment rates were monitored in the field. Chapman (1984)

found that: (1) L. longicruris produced about  $9 \times 10^9$  spores/m<sup>2</sup>/yr and L. digitata  $20 \times 10^9$  spores/m<sup>2</sup>/yr; (2) the recruitment of microscopic plants was nearly  $9 \times 10^6$  recruits/m<sup>2</sup>/yr for L. longicruris and  $1 \times 10^6$ /m<sup>2</sup>/yr for L. digitata; (3) the chances of survival from microscopic to visible size was 1 in 9 million for L. longicruris and 1 in 0.5 million for L. digitata; and (4) once plants were visible in the field, 1 in 4 survived to a year for L. longicruris and 1 in 2 for L. digitata. The greatest mortality, therefore, occurred between the time when microscopic spores reached the substratum and when sporophytes became visible. Adult plants lived up to 25 months for L. longicruris and 42 months for L. digitata.

In the British Isles and northern Europe, several species of Laminaria are abundant subtidally. Laminaria hyperborea is perhaps the most prominent and important of these species (Kain 1979). Kain (1975, 1976) found that L. digitata, which has a flexible stipe, was more tolerant to wave action than was L. hyperborea. In calmer subtidal sites, however, L. hyperborea eventually appeared to become dominant where both species had recruited. In deeper water, this species may compete with L. saccharina. Much research has been done on L. hyperborea. It extends from the low intertidal to 20+ m in depth. Kain (1979) concluded that its presence can be limited by available substratum, grazing, and irradiance. The ages of plants varied between populations, but based on the presence of annual growth rings, L. hyperborea plants could live up to 13 years (Kain 1963).

For European Laminaria spp., the maximum growth of blades occurs in late spring. Adult sporophytes of L. hyperborea, (those over one year old [Luning 1969]), usually stop growth during June (Kain 1976). Luning (1979) stated that adult sporophytes of L. digitata and L. saccharina continue to grow during the second half of the year, but at a reduced rate. He concluded that photoperiodism may be important to the regulation of seasonal growth for these species.

Laminaria pallida and Ecklonia maxima both occur in shallow water in South Africa, with L. pallida dominant below ~ 8

m depth (Velimirov et al. 1977, Dieckmann 1980). Ecklonia maxima can create bare substrata by the sweeping motion of blades on a long and flexible stipe (Velimirov and Griffiths 1979). Dieckmann (1980) found that the growth rate of L. pallida followed a seasonal cycle, with the highest rate in early summer and the lowest in winter. He also found that plants at a deeper station (14 m) had lower growth rates than those at 8-m depth. He estimated that this species may live 9+ years.

Some of the longer-bladed Laminariales from Japan can form surface canopies in shallow water. Species of Laminaria and Undaria are also extensively cultivated (Hasegawa and Sanbonsuga 1972). The biology of these species is well known (Saito 1972), but there is little information on field populations.

#### 4.3.4 Bottom Canopy Species

4.3.4.1 Fleshy and filamentous species. There are hundreds of species of fleshy and filamentous algae found in kelp forests, but only the more common species for which we have some ecological information will be discussed and illustrated. Dawson et al. (1960) described many species; North (1971a) provided a list of those most common in southern and Baja California, Mexico, while Devanny and Kirkwood (1974), Pearse and Lowry (1974), Foster et al. (1979a), and Abbott and Hollenberg (1976) listed species from central California.

There are several studies from California that show some of the effects of overstory plants on bottom canopy species, and also the effect of these bottom canopy species on the recruitment of other species. Kastendiek (1982) found at Santa Catalina Island that the red alga Pterocladia capillacea was abundant under a canopy of Eisenia. If this canopy was removed, the fucoïd Halidrys dioica was able to spread adventitiously and exclude Pterocladia. Pterocladia could flourish outside of canopies if Halidrys was prevented from preempting space. Pterocladia capillacea appeared in this case to act as a refuge species, occupying substrata under canopies of Eisenia where Halidrys could not flourish.

Several studies by Foster and his co-workers in California have paid particular attention to bottom canopy species as important members of kelp communities (Foster 1982a). Foster (1975a) placed these species into three groups for a study at Santa Cruz Island (Figure 16). Ephemerals included species such as the brown alga Colpomenia that rapidly colonized free space, but were seasonal in their appearance and disappearance. Perennials with rapid growth included the reds Pterosiphonia dendroidea and Rhodymenia californica (Figure 17), which were seasonal in their colonization of space, but could persist through time. Perennials with slow growth included Gigartina spp. (Figure 17), and the corallines (Plate 1F), which were very slow to colonize space, but could persist for several years. Colonization by these species varied with season, with most having either a spring-summer or autumn-winter period of maximum reproduction (Figure 16). Foster (1975b) found that the presence of an overstory could reduce algal diversity and the percentage cover of species below.

Following the removal of Macrocystis canopies near Santa Cruz, the annual brown alga Desmarestia ligulata var. ligulata (Figure 17) became locally abundant during spring and summer (Cowen et al. 1982; Foster 1982a). Reed and Foster (1984) also found that this species became abundant when Macrocystis and Pterygophora canopies were removed. It was particularly abundant, however, in treatments where the branches of articulated coralline algae were also removed. Desmarestia spp. may reach a few meters in length, but do not have erect stipes to hold fronds above the substratum. During the summer months, the canopy of this species may completely cover the bottom in some local sites, particularly in areas where winter storms have removed Macrocystis and Nereocystis (Foster 1982a, Cowen et al. 1982, Reed and Foster 1984).

Other species may also have an annual cycle. The fleshy red algae Polyneura latissima, Plocamium cartilagineum, Botryoglossum farlowianum (Figure 17, Plate 2D), and Phycodrys setchellii are particularly abundant during summer in

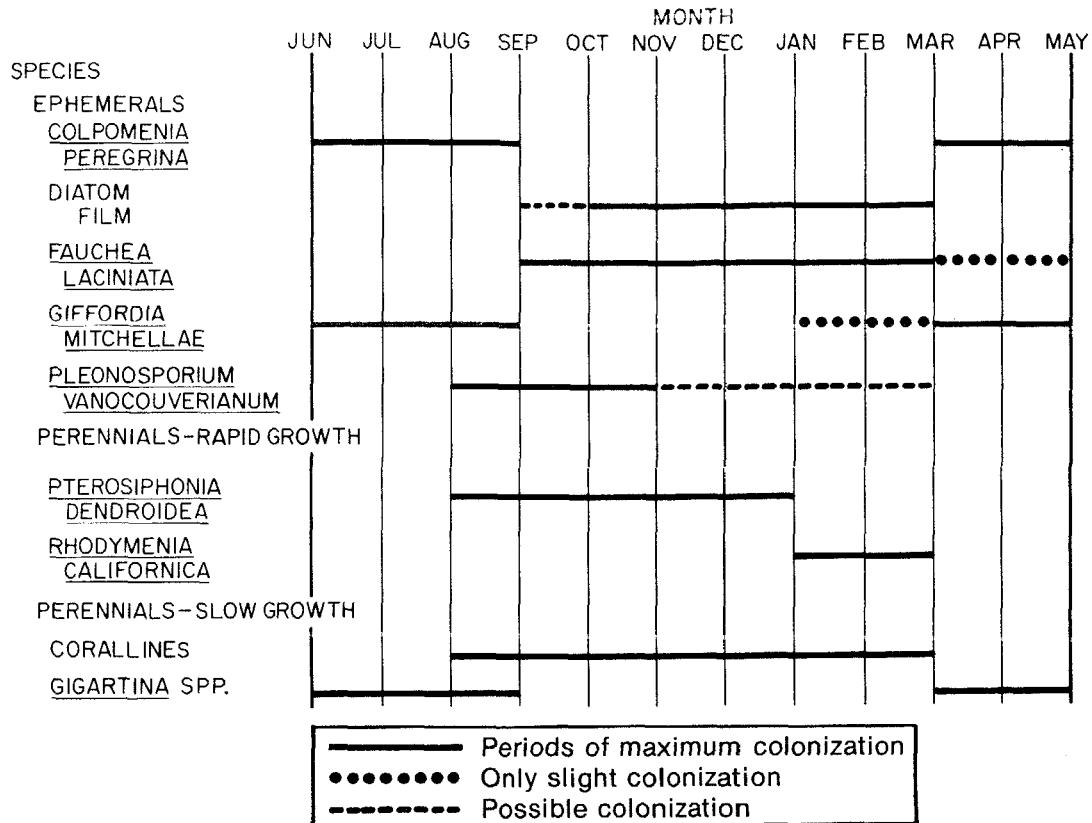

Figure 16. Colonization times for the more abundant algal species that recruited to artificial substrata in a kelp forest at Santa Cruz Island (from Foster 1975a).

northern sites near Santa Cruz (Foster 1982a), although abundance may vary at particular sites affected by local environmental changes such as sand movement (Breda 1982). Overall, there appears to be a general negative correlation between the percentage cover of *Macrocystis* canopies and the cover of bottom canopy species. This may be a direct result of shading on recruitment and growth, and/or an indirect result of overgrowth of these plants by sessile invertebrates when light is low (Breda 1982). A composite graph of several surveys at three localities in central California shows that at times when *Macrocystis* cover is high, the cover of foliose algae is low (Figure 18).

4.3.4.2 Articulated corallines. A dense cover of articulated coralline algae is common on the bottom in many kelp forests (Johansen and Austin 1970, North

1971a, Foster 1975a, 1982a). The two species of *Calliarthron* (*C. cheilosporoides* and *C. tuberculosum*, Plate 1F) are the largest of the articulated corallines along the west coast, and may have branches over 20 cm in length (Abbott and Hollenberg 1976). These species, like some of the more coarse, fleshy red algae such as *Gelidium robustum* (Figure 17; Barilotti and Silverthorne 1972), are relatively slow growing and long-lived. *Calliarthron* and related plants can also be early colonizers on bare substrata (Johansen and Austin 1970, Foster 1975a), and this genus appears to maintain coverage for many years (Johansen and Austin 1970, Foster 1975a, Reed and Foster 1984).

Reed and Foster (1984) assessed the effects of *Calliarthron* on the recruitment of other species. In a site where *Macrocystis* and *Pterygophora* canopies were



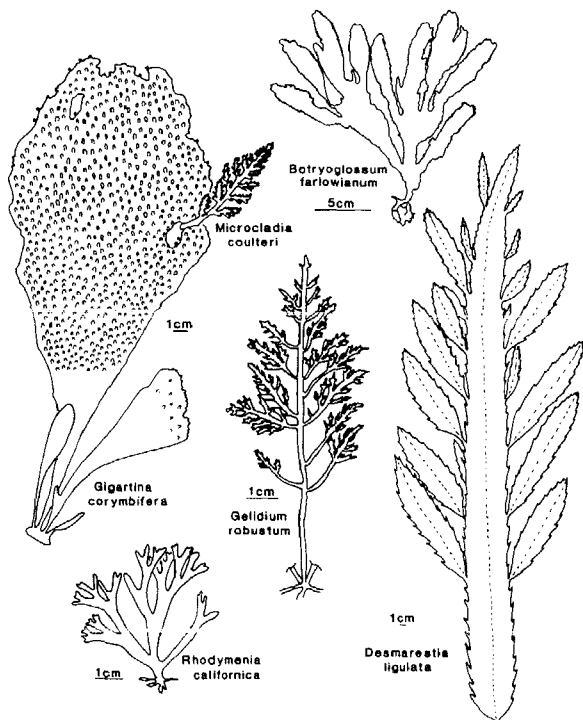

Figure 17. Common understory algae (layer 2 in Figures 3 and 6) found in kelp forests.

removed, they found that the greatest recruitment of *Desmarestia* spp. and Laminariales was in treatments from which the branches of articulated corallines were also removed. Clearances to bare rock did not increase recruitment of other species, suggesting that it is the branches themselves that inhibit recruitment. This could be caused by shading, by abrasion, by the presence of sediment which may be trapped in the articulated algae, or by small grazers concealed in the branches.

Other articulated corallines such as *Bossiella* spp. are also common in kelp communities, but little is known of their effects on other species. It is likely, however, that where these calcareous algae are abundant, they also reduce recruitment of other plants, especially *Macrocystis* (Wells 1983).

#### 4.3.5 Encrusting Species

Little is known about the effects of encrusting species in kelp communities.

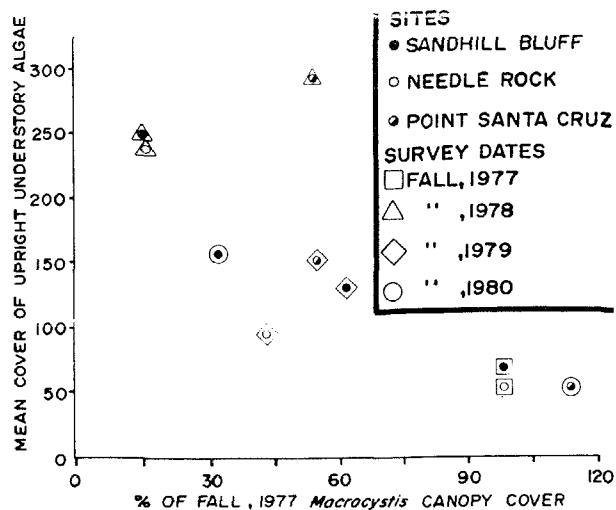

Figure 18. Relationship between *Macrocystis* canopy cover and upright (non-encrusting) understory algal cover in three kelp forests north of Santa Cruz. Total understory algal cover exceeds 100% as layering was determined. *Macrocystis* canopy cover at each site was considered 100% in fall 1977. Cover at other times is expressed as percent of this value. Understory cover was not surveyed at a Point Santa Cruz site in fall 1977.

Encrusting corallines (Plate 2A) of the genera *Lithothamnium* and *Lithophyllum* are extremely common in subtidal habitats, including *Macrocystis* forests (Abbott and Hollenberg 1976). These plants occur from the intertidal zone to depths below 100 m in the subtidal zone, and appear as pink to purple crusts on almost all surfaces not occupied by other organisms. One species, *Lithophyllum grumosum*, may form crusts up to several millimeters thick. The encrusting stages of articulated corallines are sometimes mistaken for these species. Encrusting corallines in kelp forests probably grow slowly, and certainly may persist for long periods. Many species of filamentous and foliose algae may grow epiphytically on them. Boulders covered by encrusting corallines are frequently inhabited by juvenile abalone, and in the laboratory, encrusting corallines induce settlement of abalone larvae (Morse et al. 1979). On the other hand, these crusts can reduce recruitment of some sessile animals (Breitburg 1984).

#### 4.3.6 Epiphytes

Many species of algae occur epiphytically, some as obligates on other species of algae. Even though it is an annual, Nereocystis may have many epiphytes, the commonest of which are the reds Porphyra nereocystis and Antithamnionella pacifica, and the green Enteromorpha linza (Abbott and Hollenberg 1976). P. nereocystis and A. pacifica may be found on the stipes of plants, while E. linza is usually found at the lower junctions of fronds. Microcladia californica is commonly found on Egregia menziesii in the low intertidal, while M. coulteri (Figure 17) occurs on many species of red algae as well as on large brown algae (Abbott and Hollenberg 1976).

During the summer, species of the brown alga Coilodesme may be found abundantly on Cystoseira. Coilodesme californica is particularly abundant on C. osmundacea. Diatoms (see Section 4.2.1 above) and many other algal species such as Myriogramme caespitosa, Pterochondria woodii, and Microcladia coulteri may occur on Macrocystis and other kelps.

Epiphytic algae seem to become particularly abundant as fronds senesce. This is probably not due to the epiphytes actually overwhelming plants and causing their demise, but to the general deterioration of host plants at this time. Fillion-Myklebust and Norton (1981) reported that the intertidal brown seaweed Ascophyllum nodosum sheds its epidermis, which may remove epiphytes. Moss (1982) found that continuous shedding of the outermost layers of meristoderm cell walls occurred in the perennial alga Halidrys siliquosa, and suggested that this might be a general occurrence in the Fucales. These sorts of events may be especially important for long-lived perennial species, which have a longer exposure to potential epiphytes. It has also been suggested that the abundant small crustacea that inhabit the fronds of large brown algae may benefit plants by removing epiphytes (Schieff and Choat 1980). Limpets that live on the surface of stipes may provide similar benefits (Dayton et al. 1984). Most of these ideas have yet to be tested.

#### 4.4 INVERTEBRATES

##### 4.4.1 Introduction

Giant kelp forests are inhabited by an abundant and species-rich invertebrate fauna found in a variety of habitats (Figure 6). In giant kelp holdfasts alone, Andrews (1945) found over 23,000 individuals representing nine phyla in five holdfast collections from the Monterey, California area (exact size of collections unspecified). McLean (1962) identified 204 species of invertebrates seen during 30 SCUBA dives in a primarily Nereocystis luetkeana forest south of Monterey (site described in Chapter 3). Pequegnat (1964) found over 300 species on a shallow rocky reef in southern California. The diversity of sizes, morphologies, feeding types, and behaviors is also high, making even an overview of conspicuous species and their ecology a difficult task.

Unfortunately, there is no single reference equivalent to that for the algae by Abbott and Hollenberg (1976) describing subtidal marine invertebrates in California. However, because many species range into the low intertidal zone, the recent intertidal survey by Morris et al. (1980) is very helpful, as are Ricketts et al. (1968), and for central California, Smith and Carlton (1975). These books, as well as MacGinitie and MacGinitie (1968), also include natural history information. Popular books (North 1976a, Gotshall and Laurent 1979) summarize information on the more common subtidal invertebrates likely to be found in giant kelp forests. We will discuss some of these below, particularly species that are common, and for which there is some ecological information.

We have organized groups of invertebrates functionally by feeding type, rather than taxonomically, in an attempt at ecological relevance. Feeding type distinctions, however, are often unclear as a particular species such as the sea urchin Strongylocentrotus franciscanus may graze attached plants (grazer), catch drift (detritus feeder), consume animals (predator), and perhaps use dissolved organic matter (DOM). Where

there is such overlap, we have put the animal in what appears to be the most common or notorious feeding type.

#### 4.4.2 Filter, Suspension, and Detritus Feeders

##### 4.4.2.1 Sponges (Porifera).

Sponges, along with tunicates and bryozoans, are probably the most common sessile animals in kelp forests, particularly on steeply sloping walls and in deeper water (Plate 2C). North (1971b) listed 41 species of sponges in southern California-Baja California kelp forests, with encrusting Haliclona spp., vase-like Leucilla (= Rhabdoderrella) nuttingi, and the large, spherical, orange Tethya aurantia (Figure 19) the most common. In central California, Pearse and Lowry (1974) mentioned 22 species from the Point Cabrillo kelp forest near Monterey, and McLean (1962) 11 species from Granite Creek south of Carmel, California. Species are generally similar in both central and southern California. The cobalt sponge Hymenamphistra cyanocrypta (Plate 2B) is particularly abundant as encrusting sheets on vertical walls and under ledges from Monterey south in central California kelp forests. The deep blue color is derived from a symbiotic

blue-green alga living in its tissue (Morris et al. 1980). Many sponges are important in the diets of nudibranchs, and the top shell Calliostoma annulatum feeds on T. aurantia (Gotshall and Laurent 1979).

##### 4.4.2.2 Cnidarians (Cnidaria).

Hydroids, sea anemones, solitary (cup) corals, hydrocorals, and gorgonians are ubiquitous members of the kelp forest sessile animal assemblage. The hydroids Abietinaria sp. and Aglaophenia spp. are common, and along with other species, are often early colonists of new substrata. Many hydroids are preyed upon by nudibranchs (Morris et al. 1980).

Six genera of sea anemones commonly occur in kelp forests, with the large, solitary Tealia spp. (Figure 19), Anthopleura xanthogrammica, and especially in deeper water, Metridium senile, locally abundant. The most conspicuous and abundant species is the strawberry "anemone" (not a true anemone) Corynactis californica. Colonies of this animal may completely cover vertical walls, and the orange to red bodies with white, club-shaped tentacles, are visually striking (Plate 2E). In addition to the above species, the tube-dwelling Pachycerianthus fimbriatus (Figure 19) is frequent in sand patches within and along the outer edge of kelp forests. All of these anemones feed on almost any animal tissue or detritus of appropriate size that comes within reach of their tentacles.

Anemones, like other cnidarians, have stinging structures (nematocysts), and when the animals are aggregated (e.g., Corynactis californica), may constitute a barrier to mobile benthic animals such as sea stars. Sea star prey such as gastropods may thus have a refuge from predators when surrounded by anemones or corals (Herrlinger 1983). However, the leather star Dermasterias imbricata feeds on C. californica (Rosenthal and Chess 1972).

Three species of cup corals, Balanophyllia elegans (Plate 2B), Paracyathus stearnsii, and Astrangia lajollaensis occur in giant kelp forests. The bright orange B. elegans is most common, often growing with Corynactis

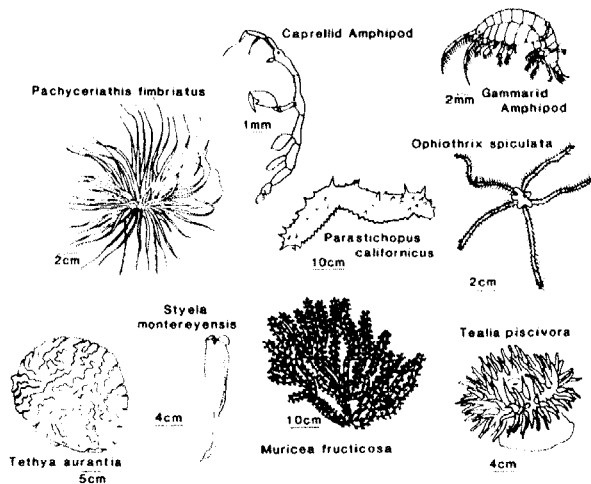

Figure 19. Invertebrate filter, suspension, and detritus feeders common in kelp forests.

californica throughout the range of Macrocystis. B. elegans has nonpelagic planulae, and studies by Gerrodette (1981) indicated dispersal distance is less than 0.5 m from the parent, perhaps accounting for the usually aggregated distribution of the species. Fadlallah (1983) estimated an average lifespan of 6-11 years for this coral at Point Cabrillo in central California, with mortality resulting from overgrowth of young corals by other sessile animals and from predation by spider crabs.

The hydrocoral Allopora californica (Plate 2F) usually occurs in deep water at the outer edge of kelp forests or on offshore pinnacles. Currents are stronger and the water cleaner in such habitats, perhaps providing reduced sedimentation and necessary food (Gotshall and Laurent 1979). Van Blaricom (pers. comm.) has observed A. californica at depths less than 10 m within a giant kelp forest where currents were strong and the water clear. Ostarello (1973) suggested sedimentation and competition with other sessile organisms for space as sources of mortality in young colonies, and breakage and abrasion as important to older colonies. An encrusting species, A. (= Styланtheca) porphyra, is occasionally also found in California kelp forests.

A number of large (to almost a meter tall), fan-shaped gorgonians are frequent in southern California kelp forests and reefs. Muricea fructicosa (Figure 19) and M. californica are most common within kelp stands, while the red Lophogorgia chilensis usually occurs in deeper water. All of these feed on plankton, and usually orientate perpendicular to the prevailing currents or surge. M. californica can be aged from rings in the base, and Grigg (1975) used age-height relationships to determine size-frequency distributions in various habitats near San Diego. These distributions, along with habitat data, were then used as measures of habitat suitability and stability for the species. Breakage from storms and increased sedimentation, burial, and abrasion were the major causes of mortality. Grigg (1975) suggested that increased sedimentation from sewage outfalls led to a reduction in the number of gorgonian colonies at Palos Verdes, an area

influenced by Los Angeles sewage discharge and where other kelp forest organisms, including Macrocystis, have also declined (see Chapter 6).

#### 4.4.2.3 Bryozoans (Ectoprocts).

Bryozoans are found almost everywhere in kelp forests, and on everything from solid rock walls to delicate algal fronds. Woollacott and North (1971) listed 59 species collected near the bottom in six geographical areas from Monterey, California, to southern Baja California, Mexico. Ten of these were considered widely distributed.

The encrusting Lichenopora novae-zelandiae, Membranipora tuberculata, and M. membranacea (Figure 6) are extremely common on algal blades, especially those of Macrocystis. Membranipora encrustations may cover up to 75% of the kelp blades at particular times in particular forests, and can grow to cover a blade almost completely in three weeks (Woollacott and North 1971). Wing and Clendenning (1971) found that blades with nearly complete cover of bryozoans required 50% higher light intensities for growth than unencrusted blades. Dixon et al. (1981) showed that plants near a thermal outfall in southern California were much more encrusted with Membranipora than were plants in a nearby kelp forest. Experiments demonstrated that blade loss from Macrocystis was correlated with the degree of encrustation, as blades tended to break off easily when heavily fouled. Predation on Membranipora by fishes may also indirectly cause blade loss (Woollacott and North 1971, Dixon et al. 1981). Fouling may be reduced on other kelps by frond abrasion, and this form of disturbance can have important effects on the entire epifaunal community on kelp blades (Fletcher and Day 1983).

Two other bryozoans are common on understory vegetation and/or on the bottom: the arborescent Thalamoporella californica, and the lacy, fan-like Phidolopora pacifica. The latter serves as habitat for numerous small gastropods and crustaceans. I. californica may have a biomass close to 300 g/m<sup>2</sup> (wet weight) in some kelp stands, about 50% of the total sessile animal biomass (Woollacott and North 1971).

Bryozoans are commonly among the first organisms to settle on newly exposed substrata in kelp forests, and may remain abundant in shaded habitats or those protected from predation (Foster 1975a, b). Selective predation by the bat star, Patiria miniata, can alter succession in the bryozoan assemblage (Day and Osman 1981). One species, Cryptoarachnidium (= Victorella) argilla, is a common early colonizer on nearshore artificial reefs in southern California (Turner et al. 1969, Grant et al. 1982). This animal forms encrusting sheets composed, in part, of consolidated sediments and can dominate reef surfaces for long periods. Dominance is probably maintained in the absence of predators by inhibiting settlement of and growing over other sessile species (LOSL 1983). Bryozoans, and sessile animals in general, appear capable of inhibiting the settlement and growth of benthic algae, even in subtidal habitats with sufficient light for algal growth. Predators (particularly fish and sea stars) of these sessile animals may mediate this competitive dominance, allowing local coexistence (Foster 1972, 1975b).

**4.4.2.4 Brittle stars, sea stars, sea cucumbers and sea urchins (Echinodermata).** Brittle stars are extremely abundant in kelp forests. They are not obvious because they are normally found out of sight under cobbles, in holdfasts, dense algal turfs, and other cryptic habitats. These animals generally feed by extending their arms and trapping food particles using the sticky mucous on the spines and podia. They are particularly active at night, when one can see hundreds of arms sticking out in the water among the holdfasts of giant kelp holdfasts.

The abundance of one of the more common brittle stars, Ophiothrix spiculata (Figure 19), ranged up to 21 individuals/100 cm<sup>2</sup> in giant kelp holdfasts from southern California (Ghelardi 1971). Andrews (1945) found total brittle star densities of up to 300/m<sup>2</sup> of holdfast (projected surface area), with O. spiculata and Amphipholis pugetana most abundant. Unfortunately, other than occasional species lists and abundance estimates, little is known of the ecology of these ubiquitous animals.

Most common sea stars in kelp forests are predators, the exceptions being the red-orange Henricia leviuscula that traps small food particles in mucous on the undersides of its arms (Morris et al. 1980), and the bat star Patiria miniata, an omnivorous scavenger. The latter is discussed in more detail under Grazers below.

Sea cucumbers use their tentacles to extract food from sediments or water, and only the tentacles of some species can normally be seen protruding from crevices, holes, or holdfasts. Common species include the red Cucumaria miniata in central California, the small (2-3 cm) orange Pachythyone rubra from Monterey to southern California, and the small, white Eupentacta quinquesemita, and large, brown Parastichopus spp. (Figure 19) throughout the range of Macrocystis pyrifera. P. rubra can occur at densities of up to 10,000/m<sup>2</sup> in some areas at San Nicolas Island off southern California (Cowen pers. comm.) Sea cucumbers are eaten by various sea stars (Morris et al. 1980).

All species of sea urchins found in kelp forests can capture and feed on drift algae, and this may be their most common mode of feeding. However, because they can graze attached plants (and are most notorious for it), they are discussed under Grazers below.

**4.4.2.5 Molluscs (Mollusca).** Numerous filter-feeding clams inhabit sandy areas in kelp forests, but the most common on hard substrata are the rock-boring pholads (Family Pholadidae) seen as siphons extending out of short calcareous tubes above the substratum. The most abundant of these is Parapholas californica, whose densities can be over 50/m<sup>2</sup> in kelp forests with relatively soft shale bottoms. Bore depth can be 30 cm, and these clams can cause considerable erosion of soft rock bottoms (Morris et al. 1980). The sea star Pisaster brevispinus is capable of extruding its stomach into pholad burrows and digesting the clams in place (Van Veldhuizen and Phillips 1978).

Mussels (Mytilus spp.) are most common in the intertidal zone, but are occasionally found in deep water (Chan 1973, Paine 1976). The size record for M.

californianus is from a subtidal reef (Chan 1973). This suggests that perhaps predation, and not the abiotic environment or food availability, limits the abundance of this genus in kelp forests. The purple-ringed rock scallop Hinnites giganteus (= H. multirugosus) is common in kelp forests, occurring attached by one valve to rock walls and inside crevices. This species is taken for food by sport divers, and is being investigated as a possible candidate for mariculture (Leighton and Phleger 1977). Two other locally abundant bivalves that attach by one valve are the jingle, Pododesmus cepio, and Chama arcana (= C. pellucida). The latter can occur stacked up at densities of near 300/0.1 m<sup>2</sup> on subtidal reefs (Pequegnat 1964). The small scallop Leptopecten latiauratus occasionally settles in large numbers on giant kelp fronds in southern California, and may cause the fronds to sink (Carter pers. comm.). Bernstein and Jung (1979) suggested that this animal, like the oceanic barnacle, is normally excluded from kelp forests by predatory fishes.

In addition to the filter feeding molluscs mentioned above, there are a few that capture particles in mucous nets. The vermetid Petalococonchus montereyensis grows in masses of intertwined calcareous tubes, each tube about 2 mm in diameter, at densities of up to 100,000 snails/ m<sup>2</sup> (Morris et al. 1980). The larger sessile snail Serpulorbis squamigerus occurs singly or in masses. Both species are preyed upon by the sea star Pisaster giganteus (Foster 1975b, Harrold 1981), and the former is a major item in the diet of this sea star in one central California kelp forest (Harrold 1981).

Although only occasionally common, the nudibranch Melibe leonina is of interest because, unlike most of its predatory relatives, this large nudibranch commonly sits on giant kelp fronds, and captures food from the passing water in its expanded oral hood (Morris et al. 1980).

4.4.2.6 Polychaete worms (Annelida, Polychaeta). Polychaetes are probably second only to crustaceans in diversity and abundance in giant kelp forests.

Polychaetes occur in almost all subhabitats within a kelp forest. Normally hidden, they are rarely seen except when samples are being sorted in the laboratory. Abundances are particularly high in kelp holdfasts (Andrews 1945, Ghelardi 1971). Many are probably predators on other small animals.

Polychaetes that are commonly visible underwater generally capture particles in the water with modified head parts or gills that project out from tubes, cracks, etc. on or in the substratum. The most common are spirorbids, whose tiny, coiled, calcareous tubes dot the surfaces of giant kelp blades and understory algae (particularly Rhodomenia spp.). Bernstein and Jung (1979) found Spirorbis spirillum most abundant in the troughs of corrugations on older Macrocystis blades (up to 3/cm<sup>2</sup>). Chemicals from the algae apparently stimulate spirorbid larvae to settle on particular species, and even parts of plants (Morris et al. 1980). The sabellid (feather duster worm) Eudistylia polymorpha is common on the bottom, where its colorful feeding and respiratory plume projects out of holes and crevices.

Perhaps the most abundant large polychaete in kelp forests is Diopatra ornata, whose parchment-like tubes, decorated with rubble and algal fragments, project above unconsolidated substrata. Densities can be so high that the worms can completely cover the bottom.

4.4.2.7 Sipunculans (Sipuncula). Peanut worms are often common in kelp forests, but like the brittle stars discussed above, are rarely seen because of their cryptic habits. They feed by eating sediment and ingesting organic matter, or by capturing small particles. Phascolosoma agassizii is probably most common, and Andrews (1945) found over 80 individuals of this species per square meter (projected holdfast area) in giant kelp holdfasts from central California. Foster (pers. obs.) found similar densities in recent collections from this area. Morris et al. (1980) indicate that sipunculans are preyed upon by gastropods.

4.4.2.8 Crustaceans (Arthropoda, Crustacea). Crustaceans are certainly the numerically dominant animals in kelp

forests, and many feed on detritus and plankton. In turn, small crustaceans are a major food of many kelp forest fishes (Quast 1971d, Bray and Ebeling 1974, Coyer 1979, Laur and Ebeling 1983; see Section 4.5 below). Gammarid and caprellid amphipods (Figure 19), mysids (Figure 14), and isopods (e.g., *Idotea*, Figure 20) are especially common on seaweeds, and low-growing algal turfs containing high densities of these animals are common fish feeding areas, particularly for perches (Bray and Ebeling 1974, Laur and Ebeling 1983). Coyer (1979) found gradients in abundance and size of particular crustaceans from the bottom to the canopy on giant kelp plants, and suggested that some size gradients may reflect size selective predation by fishes. Many of the small crustaceans migrate from the substratum into the water at night. These, along with purely planktonic species, are discussed in Section 4.2.2 above.

Hermit crabs, primarily the genus *Pagurus*, are frequent in kelp holdfasts (Andrews 1945, Ghelardi 1971), and mats of articulated corallines and other dense understory algae. They are generally scavengers and eat considerable amounts of algae (Morris et al. 1980). Little is known of the ecology of these animals in kelp forests, but they may be important grazers, particularly on small or delicate plants. Foster (pers. obs.) observed

hermit crabs, trapped within cages over fouling plates, completely remove a lush growth of foliose algae in one week.

Spider crabs, large *Cancer* spp., and other crabs and lobsters found in kelp forests are mainly grazers or predators, but all may occasionally feed on detritus.

A careful search of almost any substratum in a kelp forest will also reveal barnacles. They can completely dominate newly exposed surfaces. *Balanus crenatus* is particularly abundant in central California, while *B. pacificus* is more common in southern California. The large (over 10 cm in diameter) *B. nubilus* occurs occasionally along the entire coast.

We frequently observe dense settlement of *Balanus crenatus* in central California on bare substrata and the stipes of understory kelps. They are often fed upon by sea stars (*Pisaster* spp.) that will even ascend stipes to feed. Hurley (1975) found that flatworms were major predators on subtidal *B. pacificus*. Sheephead (*Semicossyphus pulcher*; see Section 4.5 below) also eat barnacles in southern California (Cowan 1983), particularly on newly placed artificial reefs where other prey may be less abundant (Carter, pers. comm.). The oceanic barnacle *Lepas pacifica* may be excluded from kelp forests by fish predation (Bernstein and Jung 1979).

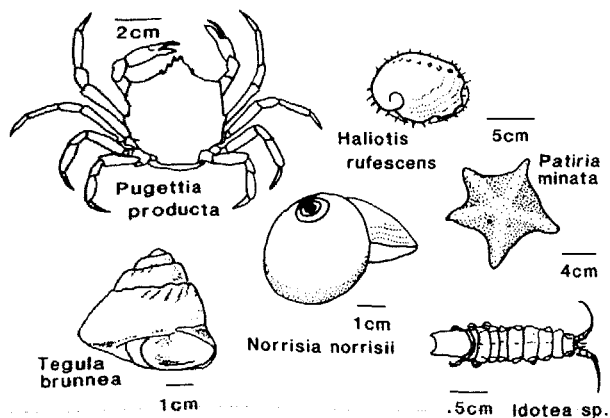

Figure 20. Common invertebrate grazers in kelp forests.

4.4.2.9 Tunicates (Urochordata, Ascidiacea). Tunicates are extremely abundant in kelp forests, forming multi-colored coverings on walls and other shaded areas. The solitary *Styela montereyensis* (Figure 19) is particularly common, and often mixed with understory algae. Rosenthal et al. (1974) observed *S. montereyensis* being eaten by the sea stars *Pisaster giganteus* and *Astrometis sertulifera*, and the whelk *Kelletia kelletii*.

Among the many colonial species (Plate 2C), the lobed, grey-pink *Cystodytes lobatus* is abundant, and may occur to depths of 200 m (Morris et al. 1980). This and other tunicates often provide habitat for small worms, crustaceans and clams, and are common prey

of sea stars and nudibranchs. Many are annual, but some, like Styela montereyensis, can live at least three years (Morris et al. 1980). North (1971b) lists 14 species of tunicates from southern California kelp forests, while Pearse and Lowry (1974) and McLean (1962) found 22 and 19 species, respectively, in two central California kelp forests.

#### 4.4.3 Grazers

At the various stages of their life cycles, seaweeds in giant kelp forests fall prey to different species of herbivorous invertebrates. Plants, however, may grow too large to be consumed by particular grazers, so that the number of grazing species that may actually remove entire plants decreases as plants get larger. There are only a few species of grazers that directly remove adult plants, but many species live on the plants, feed upon their tissues, and indirectly cause the removal of all or parts of the plants. These indirect effects include grazing of plant tissue, which may provide centers for fungal and bacterial infections that can sever blades, fronds, or holdfasts; this severing can provide sites for epiphyte growth or can weaken parts of the plants, rendering them vulnerable to removal by increased water motion or entanglement with other plants.

This section discusses the more common species of invertebrates known to have direct or indirect effects on the removal of seaweeds, particularly kelps (Table 6). There are many more herbivores present in Macrocystis forests than will be mentioned or listed here. More comprehensive species lists can be found in Leighton (1971), Smith and Carlton (1975), and Morris et al. (1980).

4.4.3.1 Sea urchins and sea stars (Echinodermata). Sea urchins are generally the most obvious grazers, and may significantly affect the distribution and abundance of macroscopic algae. Their extensive grazing effects have been recorded in tropical, temperate and boreal regions (Lawrence 1975). There has been extensive local removal of plants by sea urchins in some Macrocystis pyrifera forests in southern California (Leighton

1971; see also Chapters 3 and 5), and kelp distribution increased after sea urchins declined at one site in central California (Pearse and Hines 1979).

In most kelp forests, there are often great numbers of sea urchins, but these commonly have little effect on attached kelp (Lowry and Pearse 1973, Foster 1975a, Cowen et al. 1982), feeding mostly on drift material (Mattison et al. 1977, Vadas 1977, Duggins 1980, Harrold and Reed in press). Extensive feeding by sea urchins on attached plants appears to be related to the dispersion of individuals and their density on patches of substratum (e.g., Schiel 1982), and to behavioral changes associated with the availability of drift algae (Dean et al. 1984, Harrold and Reed in press), or even large zooplankton (Duggins 1981a).

There is a general pattern for cases where patches of kelp are completely removed by sea urchins. Dense aggregations of animals converge, and a "feeding front" is formed. The urchins in the vanguard of movement are often large individuals, tightly packed together (Leighton 1971, Dean et al. 1984). Most or all of the plants in the path of these dense aggregations are consumed or else detached from the substratum by grazing through the holdfasts or lower fronds. Sea urchins further back in the aggregations feed on this newly-freed plant material.

Large-scale removal of Macrocystis on the west coast has been primarily by two species, Strongylocentrotus franciscanus (Plate 2D), and the smaller S. purpuratus. Another species, the white urchin Lytechinus anamesus, may occasionally graze large kelp (Clarke and Neushul 1967) but is probably more important as a grazer of juveniles (Dean et al. 1984).

The large red sea urchin Strongylocentrotus franciscanus occurs on rocky substrata throughout the range of Macrocystis on the west coast (Morris et al. 1980). Leighton (1971) described large individuals of this species forming the advancing edge of a feeding front that removed a large tract of Macrocystis (~ 100 x 200 m) in the Point Loma kelp forest during 1960 (see Table 7). The



Table 6. Common invertebrate grazers which may remove tissue from kelp plants or affect recruitment. Common names are from North (1971b) and Morris et al. (1980).

Species	Common name	Grazing effects
PHYLUM ECHINODERMATA		
<u>Strongylocentrotus franciscanus</u>	Red sea urchin	Directly removes plants; consumes all parts of plants.
<u>S. purpuratus</u>	Purple sea urchin	Same as above.
<u>Lytechinus anamesus</u>	White sea urchin	May graze juveniles, and portions of holdfasts and lower fronds, weakening plant attachment; southern California to Baja only.
<u>Centrostephanus coronatus</u>	--	Grazes drift plants; possibly grazes holdfasts; southern California to Baja only.
<u>Patiria miniata</u>	Bat star	At high densities, may graze microscopic stages, affecting recruitment and early survivorship.
PHYLUM MOLLUSCA		
<u>Haliotis rufescens</u>	Red abalone	Feeds extensively on drift kelp; may graze attached stipes and sporophylls.
<u>H. fulgens</u>	Green abalone	Same as above.
<u>H. corrugata</u>	Pink abalone	Same as above.
<u>Tegula brunnea</u>	Brown turban snail	Abundant on <u>Macrocystis</u> , other kelps, and <u>Cystoseira</u> . Grazes surfaces of blades and fronds; may cause weakening of tissue.
<u>T. funebris</u>	Black turban snail	Same as above but only in low intertidal.
<u>T. pulligo</u>	Dusky turban snail	Same as above.
<u>T. eiseni</u>	Banded turban snail	Same as above.
<u>T. montereyi</u>	Monterey turban snail	Same as above.
<u>T. aureotincta</u>	Gilded turban snail	Same as above.
<u>Norrisia norrisi</u>	Norris's top snail	Same as above.
<u>Calliostoma annulatum</u>	Purple-ringed top snail	Eats kelp, but appears to feed mainly on bryozoans hydroids, diatoms, detritus.
<u>C. canaliculatum</u>	Channeled top snail	Same as above.
<u>C. ligatum</u>	Blue top snail	Same as above.
<u>Astraea undosa</u>	Wavy top snail	Found on substratum; may graze lower stipes and sporophylls.
<u>A. gibberosa</u>	Red top snail	Same as above.
<u>Mitrella carinata</u>	Carinated dove snail	Abundant on <u>Macrocystis</u> blades and fronds; feeds mainly on detritus.
<u>Lacuna unifasciata</u>	Chinkshell	Feeds on stipes, producing pits.

(continued)

Table 6 Concluded.

Species	Common name	Grazing effects
<u>Megathura crenulata</u>	Giant keyhole limpet	Minimally effects kelps; feeds on understory seaweeds and ascidians.
<u>Notoacmea inessa</u>	Seaweed limpet	Found almost exclusively on <u>Egregia menziesii</u> ; grazes fronds and causes severe weakening.
<u>Collisella instabilis</u>	Unstable seaweed limpet	Found on stipes of <u>Laminaria</u> spp. and <u>Pterygophora</u> ; no evidence of damage to plants.
<u>Ischnochiton intersinctus</u>	--	Very indirect effects; may graze algal spores.
<u>Lepidozoma cooperi</u>		Same as above.
<u>Tonicella lineata</u>	Lined chiton	Found on encrusting corallines; effects as above.
<u>Cryptochiton stelleri</u>	Gumboat chiton	Grazes on bottom; effects unknown.
<u>Aplysia californica</u>	California brown sea hare	Occasional grazing on bottom and portions of kelp plants.
<u>A. vaccaria</u>	California black sea hare	Grazes on <u>Egregia</u> ; effects unknown.
PHYLUM ARTHROPODA		
<u>Idotea resicata</u>	Kelp isopod	Found on <u>Macrocystis</u> and <u>Pelagophycus</u> ; eats holes in blades, causing weakening and providing centers for infection.
<u>I. stenops</u>	--	Found on <u>Egregia</u> .
<u>Paracerceis cordata</u>	Pillbug	May derive nourishment from kelp, but no visible damage.
<u>Ampithoe homeralis</u>	Kelp curler	Rolls and cements edges of blades to form a sticky web; likely feeds on blades.
<u>A. rubricata</u>	--	Same as above.
<u>Cymadusa uncinata</u>	--	Same as above.
<u>Limnoria algarum</u>	Gribble	Burrows into holdfasts and may cause considerable weakening.
<u>Pugettia producta</u>	Kelp crab	Mainly herbivorous; eats kelp and other algae.
<u>Taliepus nuttalli</u>	Southern kelp crab	Same as above.

smaller species, the purple urchin S. purpuratus, also shares the west coast distribution of Macrocystis. It can reach very high densities in these feeding aggregations, some 90/m<sup>2</sup> in places (Leighton 1971).

A relationship between the feeding activities of species of large and small sea urchins was also noted by Duggins

(1981b) in Torch Bay, Alaska. Large Strongylocentrotus franciscanus trapped drift plant material which the smaller species, S. droebachiensis, seemed unable to hold down by itself. It appears clear for west coast Macrocystis communities, however, that either S. franciscanus or S. purpuratus is capable of extensive grazing on attached plants.

Table 7. Concentration and biomass of two sea urchin species in 1 m<sup>2</sup> samples taken at three positions across grazing band (from Leighton 1971).

Sample number and position	Relative density in numbers		Total urchins per m <sup>2</sup>	Relative density in weight		Total urchin weight per m <sup>2</sup> (g)
	<u>S.</u> <u>fran.</u> <sup>a</sup> (%)	<u>S.</u> <u>purp.</u> <sup>b</sup> (%)		<u>S.</u> <u>fran.</u> (%)	<u>S.</u> <u>purp.</u> (%)	
1 At grazing front	94.0	6.0	32	99.3	0.7	2486
2 9 m behind front	39.0	61.0	62	64.0	36.0	1942
3 18 m behind front	15.0	85.0	46	33.5	66.5	1253

<sup>a</sup>S. fran. = Strongylocentrotus franciscanus,

<sup>b</sup>S. purp. = S. purpuratus.

The smaller white sea urchin, Lytechinus anamesus, occurs from southern California to Baja California, Mexico (Morris et al. 1980). The species feeds extensively on smaller algae, particularly foliose reds, and its grazing effects on large kelp are generally much less than that of red and purple sea urchins. Clarke and Neushul (1967) and Dean et al. (1984) reported that high densities of Lytechinus anamesus may remove adult Macrocystis plants by grazing through holdfasts and lower fronds.

Another sea urchin, the diadematid Centrostephanus coronatus, may eat kelp (Vance 1979), producing very localized effects; however, it is not an aggregating species, and its distribution is normally not extensive in kelp communities, except at some of the Channel Islands and islands offshore of Baja California, Mexico.

The bat star Patiria miniata (Figure 20) may affect algal recruitment by digesting spores and small plants when it everts its stomach over the substratum. It is found in abundance on rocky substrata (4-5 individuals/m<sup>2</sup> in many places) throughout the range of giant kelp. Bat stars are omnivores and scavengers, and also eat tunicates and

other encrusting animals. The polychaete worm Ophiodromus pugettensis commonly occurs as a commensal on the sea star's oral surface.

4.4.3.2 Molluscs (Mollusca). Many species of molluscs feed on kelp forest plants. Particularly prominent are the abundant turban and top snails (Table 6). It would be unusual for the grazing activities of these molluscs to result in the removal of adult plants. They can, however, damage fronds and blades, resulting in the severing of these parts from adult plants. Tegula spp. in Carmel Bay, when particularly abundant (~ 20 individuals per plant), has been observed to retard or prevent the growth of new sporophylls on Pterygophora californica during spring months. If storms remove most large fronds from Macrocystis, these snails can remove the remaining fronds and thus kill the entire plant (Schiel and Foster in prep.). Riedman et al. (1981) and Watanabe (1984a) recorded that the abundances of three species of Tegula were stratified with depth in a Macrocystis forest near Pacific Grove, central California. Tegula brunnea (Figure 20) was the most abundant turban snail in shallow water (-4 m depth), while T.

pulligo was more abundant in deeper areas (~11 m). There was little overlap in their distribution. The third species, T. montereyi, was the least abundant of the three turban snails, and tended to be most common at ~ 6 m depth. In addition to living and feeding on large brown algae, these species can be found at densities of ~ 40/m<sup>2</sup> on the substratum (Watanabe 1984a). Here, they may also graze small plants and spores.

Many other grazing gastropods are present in Macrocystis forests; their habits and effects are largely unknown. Several species of Calliostoma (Plate 1F) can be found on kelp plants. They are omnivores eating sessile animals as well as kelp (Morris et al. 1980), but their effects on kelp tissue are probably minimal. Mitrella carinata and Lacuna unifasciata are both small species, and can be the most abundant gastropods found on Macrocystis plants (Leighton 1971, Morris et al. 1980). Their grazing effects are also probably minimal. Norrisia norrisi (Figure 20) and species of Astraea can be abundant in kelp forests, particularly on the fronds of Macrocystis and Eisenia (Schmitt et al. 1983). N. norrisi feed on sporophylls, stipes and young fronds, and Leighton (1971) reported that stipe breakage may result from this grazing. The giant keyhole limpet (Megathura crenulata) and several species of chitons may graze algal spores from the substratum, but no significant effects on kelp have been reported. Tonicella lineata (Plate 2A) is often abundant on encrusting corallines in central California kelp forests, and may be responsible for keeping areas free of other algae.

The California brown sea hare, Aplysia californica, may be locally common in kelp forest and grazes on a variety of algae (Morris et al. 1980). We have seen mating aggregations of this species in kelp forests in Carmel Bay. During periods of calm water, individuals can occasionally be found in the tops of Pterygophora californica, grazing on the blades. A. vaccaria, the California black sea hare is most common in southern California and Baja California, Mexico. This species may be the world's largest gastropod, with individuals over 0.5 m

long and weighing nearly 16 kg. Egregia is reported as its primary food (Morris et al. 1980).

Several species of abalone live in kelp forests, and all consume many species of algae. The red abalone (Haliotis rufescens; Figure 20), the green abalone (H. fulgens), and the pink abalone (H. corrugata) were important species in sport and commercial fisheries but, recently, the harvest of the primarily intertidal black abalone (H. cracherodii) has increased, probably because of the impacts of commercial and sport fishing on the former species (see Section 6.2.2.2). Hines and Pearse (1982) report that abalone populations within a kelp forest foraged by sea otters exhibit high recruitment, growth rates, and turnover rates. Abalone feed extensively on Macrocystis (Leighton 1971, Tegner and Levin 1982). This is almost entirely drift material, however, captured by the animals with their powerful feet. Species of Haliotis have little effect on attached plants.

4.4.3.3 Crustaceans (Arthropoda, Crustacea). The kelp isopod Idotea (= Pentidotea) resecata (Figure 20) dwells on the upper fronds and blades of Macrocystis, and can heavily graze the blades (Jones 1971). North (1966) reported that this feeding activity once extensively damaged the canopy of Macrocystis in a wide area of the Point Loma kelp forest. The holes in blades resulting from their grazing may also be sites for fungal and bacterial infections. Another isopod, the pillbug Paracerceis cordata, probably causes little damage to kelp plants.

The gribble Limnoria (= Phycolimnoria) algarum may occasionally cause adult Macrocystis to be detached from the substratum. This isopod can be abundant in Macrocystis holdfasts (Andrews 1945). It burrows into the haptera, forming tunnels which may severely weaken the holdfasts (Jones 1971). Increased water motion may then dislodge these plants. A related isopod can cause considerable weakening of giant kelp holdfasts in Argentina (see Section 3.3.3).

The kelp curling amphipods Ampithoe humeralis, A. rubricata, and Cymadusa

uncinata build tubes in kelp laminae by curling the edges of blades and sticking them together. They eat kelp, and may puncture blades with their spines and hooks (North and Schaefer 1964).

Other crustaceans known to feed on kelp forest seaweeds are various spider crabs (Hines 1982), especially Taliepus nutalli, and the kelp crab Pugettia producta (Figure 20). Although often abundant, their grazing does not appear to have a great effect on plants.

#### 4.4.4 Predators

Many species of predatory invertebrates inhabit or frequent Macrocystis forests, but overall, little is known about their effects on the dynamic relationships of organisms within kelp stands. Table 8 lists the more

common or larger predators found in kelp forests on the west coast of North America. This list includes only a small subset of species that may be found in many localities. More comprehensive lists can be found in Ricketts et al. (1968), North (1971b), Smith and Carlton (1975), and Morris et al. (1980).

4.4.4.1 Sea stars (Echinodermata). Several species of predatory sea stars may be easily located in most kelp forests. The larger species (see Table 8) can be voracious predators of other invertebrate species, especially favoring sea urchins, gastropods, and chitons. Intertidally, sea stars of the genus Pisaster directly affect the species composition and may allow successional events in some communities (Paine 1974). They may preferentially consume mussels, the competitively dominant species on some

Table 8. Common invertebrate predators found in Macrocystis forests.

Species	Common name <sup>a</sup>	Predatory effects
PHYLUM ECHINODERMATA		
<u>Dermasterias imbricata</u>	Leather star	Will eat the purple sea urchin <u>S. purpuratus</u> , anemones, and corals.
<u>Astrometis sertulifera</u>	--	Occasionally feeds on chitons and sea urchins.
<u>Pisaster ochraceus</u>	Ochre star	Eats snails, limpets, chitons, and barnacles.
<u>P. giganteus</u>	--	Same as above.
<u>P. brevispinus</u>	--	Same as above.
<u>Pycnopodia helianthoides</u>	Sunflower star	Commonly eats sea urchins, snails, chitons, crabs, and other sea stars.
<u>Patiria miniata</u>	Bat star	May eat small <u>Lytechinus anemesus</u> .
PHYLUM MOLLUSCA		
<u>Navanax inermis</u>	--	Eats other opisthobranchs.
<u>Pleurobranchaea californica</u>	--	Will eat <u>Navanax</u> , anemones, and other members of its own species.
<u>Loligo opalescens</u>	Common squid, sea avian, calamari	Feeds mainly on shrimp-like crustaceans.

(continued)

Table 8 Concluded.

Species	Common name	Predatory effects
<u>Octopus bimaculoides</u>	Two-spotted octopus	Feeds mainly on molluscs (limpets, abalone, other gastropods) and crustaceans (e.g., crabs).
<u>O. rubescens</u>	Red octopus	Same as above.
<u>Octopus dofleini</u>	North Pacific giant octopus	Same as above.
<u>O. micropyrsus</u>	--	Found in kelp holdfasts; feeds on small molluscs and crustaceans.
<u>Cypraea spadicea</u>	Chestnut cowrie	Feeds on snails' eggs, anemones, ascidians.
<u>Amphissa columbiana</u>	Wrinkled dove snail	Common in kelp holdfasts; little known.
<u>Conus californicus</u>	California cone	Feeds on gastropods, bivalves, polychaetes and others.
PHYLUM ARTHROPODA		
<u>Panulirus interruptus</u>	California spiny lobster	Feeds on a wide variety of invertebrates.
<u>Loxorhynchus grandis</u>	Sheep crab	Feeds on molluscs and echinoderms.
<u>L. crispatus</u>	Moss, masking crab	Feeds on a variety of invertebrates.
<u>Pelia tumida</u>	Dwarf crab	Common in kelp holdfasts; feeds on a variety of small invertebrates.
<u>Cancer antennarius</u>	Rock crab	Common around bases of kelp plants; eats a variety of invertebrate prey.
<u>C. anthonyi</u>	Yellow crab	Eats a variety of invertebrate prey.
<u>C. jordani</u>	Hairy cancer crab	Common in kelp holdfasts; unknown feeding.
<u>C. productus</u>	Red crab	Eats a variety of invertebrate prey.
<u>Lophopanopeus bellus bellus</u>	Black-clawed crab	Common in kelp holdfasts.

<sup>a</sup> From North (1971b) and Morris et al. (1980).

shores of the Pacific northwest. Because of their effects, they have been called "keystone species" (Paine 1966). It has also been recorded that the sudden intrusion of sea stars in tidepools will cause the rapid exit of sea urchins, which may eventually allow many species of large algae to colonize (Paine and Vadas 1969). The indirect effects of sea stars on algal assemblages in subtidal habitats, however, are less certain.

The large sunflower star Pycnopodia helianthoides (Figure 21) commonly consumes sea urchins. Duggins (1983) found that predation of sea urchins by this starfish in Torch Bay, Alaska can create short-lived patches free of herbivores, which may significantly affect subtidal algal assemblages. P. helianthoides will also eat chitons, gastropods, crabs, and other sea stars. Pisaster spp. (Figure 21) have a similar

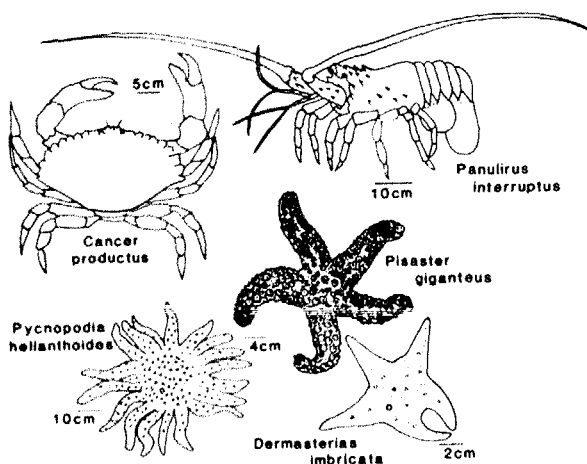

Figure 21. Some common invertebrate predators in kelp forests.

broad diet (over 40 prey items for *P. giganteus* in a central California kelp forest [Harrold 1981] and 34 in southern California [Rosenthal 1971]), as does *Astrometis sertulifera*. However, the latter are less effective than *Pycnopodia* at capturing large sea urchins. The leather star *Dermasterias imbricata* (Figure 21) will eat the smaller purple sea urchin *Strongylocentrotus purpuratus* (Rosenthal and Chess 1972) as well as the anemones *Corynactis californica*, *Anthopleura xanthogrammica*, *A. elegantissima* and *Metridium senile* (Annett and Pierotti 1984). Sebens (1983) indicated that predation by *Dermasterias* and shading by algae may prevent *Anthopleura* spp. from occupying subtidal habitats. Schmitt (1982) found that sea stars and other predators affected the distribution of *Tegula* spp. on subtidal reefs at Catalina Island. In the Point Cabrillo kelp forest in central California, sea star and fish predation limits *T. brunnea* to shallow water where understory vegetation provides a partial refuge from these predators (Watanabe 1984a).

Schroeter et al. (1983) found that the bat star *Patiria miniata* could affect the distribution of the small white sea urchin *Lytechinus anamesus* on a small scale in a kelp stand near San Onofre (San Diego County). *Patiria* could capture and consume *Lytechinus* in experiments done in

the laboratory. From the escape response of *Lytechinus* noted in the laboratory, these workers concluded that the small-scale distribution of the species in the kelp forest was the result of the predatory activities of *Patiria*. Preferential feeding on particular bryozoans by *Patiria* also affects succession in bryozoan assemblages (Day and Osman 1981).

#### 4.4.4.2 Molluscs (Mollusca).

Several species of octopus are found within kelp forests. They feed on a wide variety of animals, but mostly on gastropods and crabs. Schmitt (1982) indicated that predation by *Octopus bimaculatus* and other animals can have important effects on the distribution of *Tegula* spp. at Catalina Island. *O. bimaculatus* also prey on *Norrisia norrisi*. Moreover, if this snail is only damaged by *O. bimaculatus*, subsequent fouling by barnacles on the damaged shell makes the snail less able to cling to kelp plants, and reduces its ability to escape from other benthic predators such as sea stars (Schmitt et al. 1983). Some species of octopus are large and can even capture and consume large abalone. The cryptic coloring and elusive nature of octopuses render them difficult to observe in their natural habitats.

The common squid *Loligo opalescens* is an infrequent visitor to kelp habitats. It feeds mainly on euphausiids and other shrimp-like crustaceans.

Many species of nudibranchs are commonly seen in kelp forests. The opisthobranchs include some quite colorful species, and provide a striking contrast to the often drab surroundings of their benthic habitats. They feed on sponges, anemones, hydroids, and other opisthobranchs. We have listed only two large species, *Navanax inermis* and *Pleurobranchia californica* (Table 8).

Predatory prosobranch gastropods are abundant in kelp forests, particularly around giant kelp holdfasts. The chestnut cowrie *Cypraea spadicea* feeds on gastropods, ascidians, and anemones. *Conus californicus*, the California cone, eats bivalves, polychaetes, gastropods, and various other small animals (Morris et

al. 1980). The whelk, Kelletia kelletii, is a carnivorous scavenger with a diet similar to Pisaster giganteus. Rosenthal (1971) found, from observations made off San Diego, that these two species often converge on the same food source and feed together, even though P. giganteus occasionally eats K. kelletii. The miter Mitrae idae can be common in kelp forests and feeds on sipunculans (Fukuyama and Nybakken 1983). Little is known about the wrinkled dove snail Amphissa columbiana, which is particularly common in holdfasts of Macrocystis (Andrews 1945).

4.4.4.3 Crustaceans (Arthropoda, Crustacea). The spiny lobster Panulirus interruptus (Figure 21) has been found as far north as Monterey Bay, but is common only south of Point Conception. It was once more abundant than it is today (see Chapter 6), but continual removal of this food species by commercial fishermen and recreational divers has reduced its numbers. Panulirus feeds on a wide variety of invertebrates, and Tegner and Dayton (1981) and Tegner and Levin (1983) suggested that it may be an important predator of sea urchins.

The last group of predatory invertebrates which we will mention is the true crabs, whose members are abundant in kelp forests. Several of the species listed in Table 8 are common in or around Macrocystis holdfasts. Species of Cancer (Figure 21) and Loxorhynchus are larger crabs which feed on various invertebrates. The dwarf crab Pelvia tumida and the xanthid crab Lophopanopeus bellus bellus are commonly found in kelp holdfasts (Andrews 1945), but little is known about their feeding habits.

## 4.5 FISH

### 4.5.1 Introduction

As is true of most other organisms discussed in this chapter, almost all species of fish found in kelp forests can also be found on subtidal reefs devoid of surface canopy kelps, and fishes common in kelp forests are among the first to colonize newly placed artificial reefs with almost no macroalgae (Turner et al. 1969, Grant et al. 1982, LOSL 1983). The heterogeneous kelp forest environment

does, however, provide an important source of food and shelter for many fishes. As many as 125 species have been reported to inhabit rocky reefs and kelp forests off southern California (Feder et al. 1974). Quast (1971a) listed 57 species associated with kelp forests in southern California; Burge and Schultz (1973) reported 77 species from the Diablo Cove area near San Luis Obispo, and Miller and Geibel (1973) identified 67 species between San Simeon and Monterey. Detailed descriptions of these species can be found in the above references or in popular books such as Fitch (1971, 1975), Gotshall (1981), and Eschmeyer et al. (1983). Choat (1982) provides an excellent review of the ecological consequences of fish feeding in temperate waters. The more common fishes frequently found in kelp forests are discussed below and many are illustrated in Figure 22.

There are a number of differences in kelp forest fish assemblages between central and southern California, and these have been largely attributed to differences in water characteristics. In particular, southern California waters are generally less turbid, less turbulent, and warmer. Tropically-derived species or families are much more prevalent there, and include the Clinidae (clinids), Gobiidae (gobies), Pomacentridae (damsel-fishes), the Labridae (wrasses), the Serranidae (basses), and the Kyphosidae (sea chubs) (Ebeling et al. 1980a, b). Temperate families include the Embiotocidae (surfperches), the Scorpaenidae (rockfishes), the Hexagrammidae (greenlings), and the Cottidae (sculpins) (Ebeling et al. 1980a, b). Waters of central California have fewer tropically derived species and fewer families, but generally more species per family, particularly of rockfishes.

Even though both temperate kelp forests and tropical reefs occur at similar depths and have diverse fish assemblages, the behaviors of the fishes in the two habitats are different. The tropics are characterized by a daily shift in activity between diurnal and nocturnal species that may be a result of changes in the presence of predators (Hobson 1973). In temperate kelp forests near Santa Barbara, the replacement of species in the



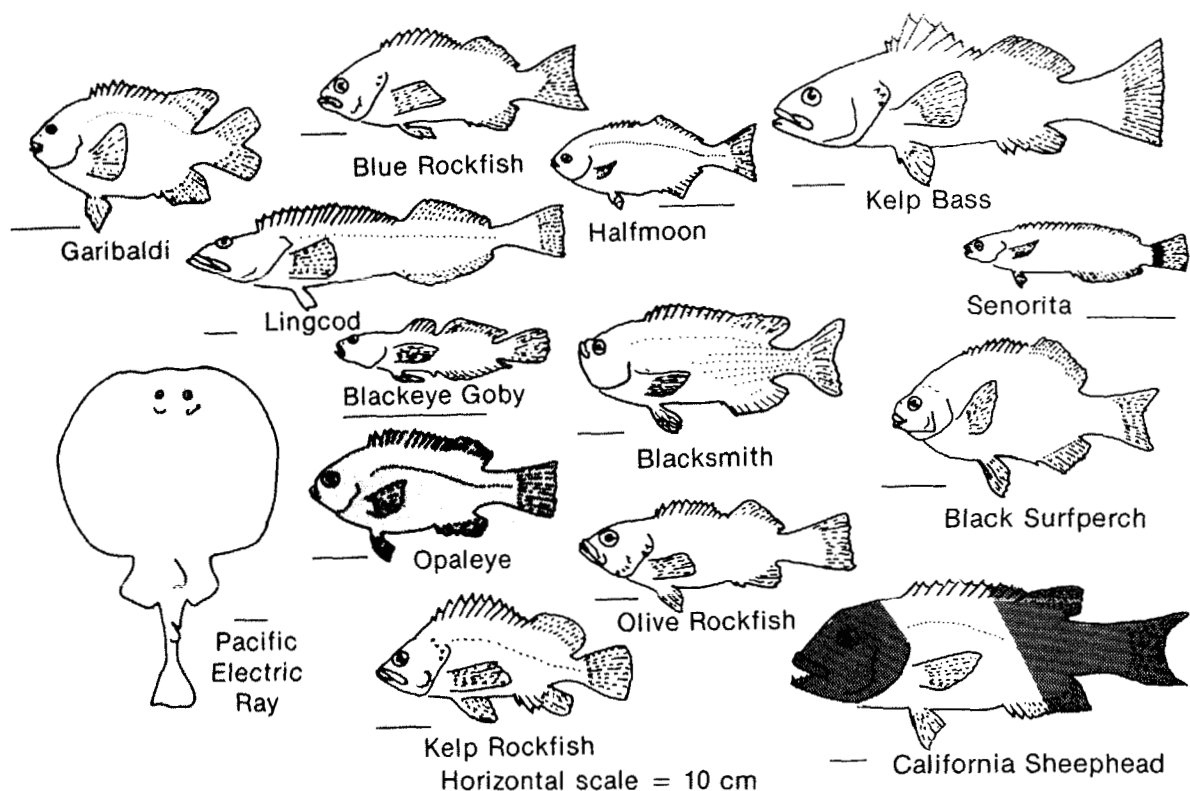

Figure 22. Some common kelp forest fishes (redrawn from Miller and Lea 1972).

water column at dusk is not as dramatic; there are a few nocturnal species, but the majority are diurnal (Ebeling and Bray 1976). The number of nocturnal individuals and species, however, is greater in the warmer water off Catalina Island (Hobson and Chess 1976, Hobson et al. 1981). Species that are of tropical origin do show the apparently programmed activity pattern of tropical species, even though predation may be reduced (Ebeling and Bray 1976, but also see Hobson et al. 1981).

Kelp forest fishes can be divided into two groups according to the sub-habitat occupied within kelp forests: canopy-midwater orienting species, and bottom-orienting species. Feeding categories can also be distinguished for species in the habitat groups (Table 9) and include browsers, planktivores, and predators on motile prey (Choat 1982). Browsers feed primarily on sessile organisms, whereas predators on mobile prey

(ambushers, searchers, chasers) feed on invertebrates and fishes. Planktivores feed on open-water zooplankton.

#### 4.5.2 Canopy-midwater Species

Only two species can truly be classified as browsers in the canopy-midwater zones: the *senorita* (Figure 22), *Oxyjulis californica*, a member of a tropical family (Labridae), and the kelp surfperch *Brachyistius frenatus* in the temperate family Embiotocidae. The *senorita* is an orange-colored, cigar-shaped fish with a pointed snout and protruding teeth. It generally swims in schools of several to hundreds of individuals, and ranges from the canopy to the bottom (Bray and Ebeling 1974). This species is a daytime feeder on the bryozoan *Membranipora* sp., which grows on *Macrocystis pyrifera*, hydroids, kelp-associated crustaceans, and some open-water plankton (Bernstein and Jung 1979). Bernstein and Jung (1979) suggested that,

Table 9. Subhabitat and feeding categories of common kelp forest fishes.

Subhabitat	Browsers	Planktivores	Predators on mobile prey
Canopy-Midwater Species	Senorita ( <i>Oxyjulis californica</i> )	Blue rockfish ( <i>Sebastes mystinus</i> )	Giant kelpfish ( <i>Heterostichus rostratus</i> )
	Kelp surfperch ( <i>Brachyistius frenatus</i> )	Blacksmith ( <i>Chromis punctipinnis</i> )	Kelp bass ( <i>Paralabrax clathratus</i> )
	Halfmoon <sup>a</sup> ( <i>Medialuna californiensis</i> )	Juvenile rockfish ( <i>Sebastes</i> spp.)	Olive rockfish ( <i>Sebastes serranoides</i> )
		Juvenile kelp bass ( <i>Paralabrax clathratus</i> )	Black rockfish ( <i>Sebastes melanops</i> )
Bottom Species	Garibaldi ( <i>Hypsypops rubicundus</i> )		Surfperch
	Surfperch		California Sheephead ( <i>Semicossyphus pulcher</i> )
	California sheephead ( <i>Semicossyphus pulcher</i> )		Rockfish ( <i>Sebastes</i> spp.)
	Opaleye <sup>a</sup> ( <i>Girella nigricans</i> )		Greenling ( <i>Hexagrammos</i> spp.)
		Lingcod ( <i>Ophiodon elongatus</i> )	
		Cabezon ( <i>Scorpaenichthys marmoratus</i> )	
		Sculpin	
		Goby	
		Torpedo ray ( <i>Torpedo californica</i> )	

<sup>a</sup>Also grazers.

in the absence of seniorita predation, kelp fronds would be much more heavily fouled by sessile animals, and perhaps destroyed by herbivorous crustaceans. Senioritas also clean other fishes, feeding on scales and parasitic copepods. At night, this fish buries itself in patches of rubble and sand, a characteristic behavior of many labrids.

The diet of the kelp surfperch is similar to that of the seniorita. This kelp-colored fish consumes copepods, gammarid amphipods, bryozoans, and occasionally ectoparasites on other fish (Bray and Ebeling 1974, Coyer 1979). Kelp surfperch feed during the day, usually starting at dawn, and have full stomachs by noon. This species is very rare in areas without large seaweeds (Carr pers. comm.).

The halfmoon *Medialuna californiensis* (Family Scorpididae, Figure 22) is a browser, but consumes both invertebrates and algae in southern California (Quast 1971d, Feder et al. 1974). The halfmoon occurs singly or in loose schools, browsing on seaweeds, and along with the opaleye (see below), is the only abundant, large fish that regularly feeds on seaweeds in California giant kelp forests. Other than an occasional bite mark, halfmoon appear to cause little damage in large stands of kelp. If stands are reduced to a few plants, however, these fish can completely remove blades, causing the plants to die. This has inhibited transplant efforts to restore giant kelp (North 1968), and to establish *Macrocystis* and *Pterygophora californica* on a large artificial reef (Grant et al. 1982, LOSL 1983).

Predators feeding on large, mobile prey in the canopy-midwater regions include the giant kelpfish (Heterostichus rostratus), the kelp bass (Paralabrax clathratus), the kelp rockfish (Sebastes atrovirens), the olive rockfish (S. serranoides), and the black rockfish (S. melanops). Young olive rockfish eat plankton (Hobson and Chess 1976, Love and Ebeling 1978).

The cryptically-colored giant kelpfish occurs throughout the water-column in close association with Macrocystis and other seaweeds. Although rarely seen in central California, it is particularly common in kelp forests around islands off southern California. The giant kelpfish feeds during the day in open water, on substratum-oriented prey such as mysids, isopods, amphipods, shrimp and fish (Coyer 1979, Hobson et al. 1981).

The kelp bass (Figure 22) was described by Quast (1968, 1971a) as a medium-sized, generalized carnivore occupying a wide variety of environments. Kelp bass tend to move only slightly among reefs (Young 1963) and will congregate at heavily fished and chummed sites. Food habits change with age; juveniles (< 299 mm) eat primarily benthic invertebrates and plankton, but switch to fish when they grow larger (Love and Ebeling 1978, Hobson et al. 1981). Kelp bass over 30 cm eat predominately fish, although invertebrates occasionally are found in their stomachs. In southern California, kelp bass are regarded as one of the primary fish predators in the kelp forest. This species is not as common in central California.

The kelp rockfish (Figure 22), a common cryptic species, can be found throughout the water column associated with kelp. Kelp rockfish hover adjacent to kelp stipes, during the day and night in central California, but both rest on the bottom and hover at night in southern California (Hobson and Chess 1976, Van Dykhuizen 1983). They feed on a wide size range of prey items, including plankton, epibenthic invertebrates, and juvenile fishes. Kelp rockfish feed primarily at dawn and at night, but will take prey whenever it is abundant.

The olive rockfish (Figure 22), common to both central and southern California kelp forests, is a large midwater predator. Unlike kelp bass, which they superficially resemble, adult olive rockfish generally remain in the same location on a particular reef (Love 1980). Juveniles, subadults, and adults differ in their feeding behavior (Hobson and Chess 1976, Love and Ebeling 1978, Love and Westphal 1981). Juvenile olive rockfish < 55 mm form aggregations in the water column, and feed on copepods, amphipods and larvae. Intermediate-sized juveniles, 55-65 mm, feed day and night on amphipods, cumaceans, and mysids. Large juveniles (> 65 mm) are active at night, hovering in midwater aggregations over the bottom, and feeding on amphipods, mysids, and other crustaceans. Adults may feed day or night on juvenile fishes, octopus, and squid. The local distribution and food habits of the olive rockfish in central California are similar to those of the kelp bass in southern California (see discussion in Love and Westphal 1981).

Black rockfish are rare in southern California kelp forests, but common in central California. This species occupies the midwater zone, solitary or interspersed with schools of blue rockfish. Juvenile rockfish are important prey for the black rockfish during the upwelling period (spring-early summer), while polychaetes are important prey at other times of the year (Roberts 1979).

Kelp forest fishes that feed predominantly on plankton include blue rockfish (Sebastes mystinus), the blacksmith (Chromis punctipinnus), and juvenile rockfishes (Sebastes spp.). Blue rockfish (Figure 22) are the most common rockfish in the kelp forests of central and southern California. They occupy the open-water habitat in kelp forests or over deep, rocky reefs devoid of kelp. Individuals of this species occur alone, in loose schools, or in large aggregations (Miller and Geibel 1973). Blue rockfish are also one of the most important sport species in central and northern California (Miller and Geibel 1973). The habitats of the blue rockfish in central California are similar to those of the blacksmith (see below) in southern California. The feeding habits of the blue rockfish differ

between the upwelling and non-upwelling seasons (Miller and Geibel 1973, Love and Ebeling 1978, Roberts 1979). Pelagic tunicates and crustaceans are important prey in the upwelling season, whereas algae, euphausiids and larval fishes are eaten in the non-upwelling season. Hallacher (1977) also found algae in blue rockfish stomachs.

The most common fish in the kelp forests of southern California is the blacksmith (Figure 22). This damselfish usually aggregates in the midwater on the up-current edge of kelp forests during the day. It feeds on larvaceans, copepods, cladocerans, and various larvae. Blacksmith retreat to shelter holes and crevices at dusk and come out again at dawn (Bray 1981). As a result of feeding on plankton at the edge of kelp forests during the day and defecating in the shelter holes at night, blacksmith transport extrinsic energy into the kelp forest, and their feces provide a food source for the benthic invertebrates (Bray et al. 1981).

Juvenile rockfishes are the most abundant planktonic feeders during the upwelling season in central California (Burge and Schultz 1973). They recruit to kelp forests initially around May, and remain there until November or December when winter storms begin. The seven species studied by Singer (1982) were divided into two groups: those which fed primarily in the water column, and those which fed on substrate-oriented prey. All species were generally active and fed during the day. These juvenile rockfishes provide an important source of prey for many adult kelp forest fishes, including kelp bass (Young 1963), adult rockfishes (Roberts 1979, Love and Westphal 1981), and ling cod (Miller and Giebel 1973). Many nearshore birds also feed on young-of-the-year rockfish in kelp forests (Follett and Ainley 1976, Hubbs et al. 1970, Ainley et al. 1981, Carr 1983).

A number of small cryptic fishes occupy the surface and midwater portions of the water column, but only in the presence of Macrocystis pyrifera. The kelp gunnel (Ulvicola sanctaerosae), kelp clingfish (Rimicola muscarum), giant kelpfish (Heterostichus rostratus) and the

manacled sculpin (Synchirus gilli) all maintain close proximity to vertical fronds and the canopy of giant kelp, feeding on small, mobile prey.

As pointed out in the introduction, almost all fishes found in kelp forests can be found in rocky habitats without kelp. The relative importance of the Macrocystis habitat, however, may be much greater for the early life stages of some fishes than for adult conspecifics. During this early period of high vulnerability to predation and pressing metabolic requirements for growth, the refuge made available by, and prey species associated with, kelp structure may enhance local survivorship of recently recruited fishes. The abundance of young rockfish (Leaman 1976, Burge and Schultz 1973, Miller and Giebel 1973, Carr 1983) and kelp bass (Larson and DeMartini in press) throughout the water column in kelp seems to be strongly influenced by the presence of M. pyrifera.

#### 4.5.3 Bottom Species

Fishes that occur in the bottom zone of kelp forests can also be classified as browsers or predators on mobile prey. Here again, there are differences with respect to species composition between central and southern California. Browser-type fishes feeding on sessile invertebrates include the garibaldi (Hypsypops rubicunda), the rock wrasse (Halichoeres semicinctus), and some of the surfperches (Embiotocidae).

The most visible fish in the bottom zone is the bright orange ocean goldfish or garibaldi (Figure 22). It ranges north to Monterey Bay, but is rare north of Point Conception (Miller and Lea 1972). Garibaldi defend territories which include a feeding area, a shelter hole, and for some, a breeding site (Clarke 1970, 1971). Territories are defended throughout the year, and up to four years at the same site. Some garibaldi are not territorial; juveniles do not defend territories, and females do not defend home ranges as strictly as males. The nesting site consists of a patch of filamentous algae that is kept free of other organisms and detritus by the male during the breeding season. This tends to increase algal

branch density, which then decreases after the breeding season (Foster 1972). Female garibaldi lay eggs on this turf from May to October, and young disperse in the plankton and settle in shallow water (Clarke 1970). Newly settled garibaldi feed on copepods, isopods, cladocerans, and amphipods. Adults feed on sponges, cnidarians, bryozoans and sometimes, polychaetes, nudibranchs, and crabs. This species is active by day, retreating to shelter holes at night.

Surfperches in the Family Embiotocidae are extremely common in temperate fish assemblages. Members of this family are viviparous, giving birth to live young which already resemble the adults. The surfperches feed primarily on small crustaceans, brittle stars, clams, mussels, limpets, polychaetes, and snails which inhabit the "turf" on the rocky substrate (Feder et al. 1974, Ellison et al. 1979, Haldorson and Moser 1979, Laur and Ebeling 1983). The most common surfperches observed in southern California kelp forests are the black surfperch (Embiotoca jacksoni, Figure 22), white surfperch (Phanerodon furcatus), and the pile perch (Damalichthys vacca). Rainbow perch (Hypsurus caryi), and rubberlip surfperch (Rhacochilus toxotes) are also commonly observed near the bottom, feeding in turf. The striped surfperch (E. lateralis) occurs off Santa Barbara but is much more abundant off central California (Haldorson and Moser 1979). Many surfperches are able to ingest the turf material, select and swallow the preferred food items, and reject the undesired material.

The sheephead (Semicossyphus pulcher, Figure 22), a member of the wrasse family, is a common reef inhabitant in southern California. This species is a protogynous hemaphrodite (females change into males), with the female coloration being uniformly red or purple with a white chin, and the males having a black body with a pink band behind the head and a white chin. Sheephead are solitary wanderers, feeding (by crushing food in the throat before swallowing) on urchins, mussels, crabs, snails, squid, and bryozoans (Feder et al. 1974). Tegner and Dayton (1981) suggested that sheephead may have a significant effect on sea urchin abundance, and Nelson

and Vance (1979) suggest that the behavior of the sea urchin Centrostephanus coronatus is related to sheephead predation. Cowen (1983), working on a reef at San Nicolas Island, found that Strongylocentrotus franciscanus densities increased, and distribution changed when sheephead were removed. Sheephead do not appear to be important predators on sea urchins in the mainland kelp forest at San Onofre (Dean et al. 1984). Sheephead retreat to shelter holes at night, and some produce a mucous envelope that surrounds the body (Wiley 1973).

Like the midwater canopy-dwelling halfmoon, the opaleye Girella nigricans (Family Girellidae, Figure 22) browses on both invertebrates and algae (Quast 1971d, Feder et al. 1974), and can cause extensive damage to isolated giant kelp plants (see discussion under halfmoon above). Opaleye are extremely common in southern California kelp forests, but relatively rare north of Point Conception.

The rockfishes (Scorpaenidae) are an important constituent of the bottom-dwelling fauna of kelp forests in central California (Hallacher 1977). The common demersal species are the grass rockfish (Sebastes rastrelliger), black-and-yellow rockfish (S. chrysomelas), gopher rockfish (S. carnatus), copper rockfish (S. caurinus), and treefish (S. serriceps). The grass rockfish is generally restricted to rocky bottoms < 30 m deep where it eats crabs and small fishes (Feder et al. 1974). Copper rockfish, although not abundant, inhabit rocky reef areas with or without kelp. This species feeds primarily on crabs, shrimp, cephalopods, and fishes (Feder et al. 1974, Prince 1975). The black-and-yellow and gopher rockfishes are territorial and are segregated by depth (Larson 1980a, b, c). These two species feed on similar prey such as crabs, shrimp and octopus. Treefish are common in southern California, but rare in central California (Miller and Lea 1972). Treefish are territorial, inhabiting rocky crevices (Feder et al. 1974). They feed on shrimp, crabs, and fishes at nocturnal or crepuscular hours (Hobson et al. 1981).

Fishes belonging to the greenling family (Hexagrammidae) are also commonly

observed in the bottom zone. These species include the painted greenling (Oxylebius pictus), kelp greenling (Hexagrammos decagrammus), and the lingcod (Ophiodon elongatus). Hexagrammidae eggs are attached to rocks and are often guarded by the male. The painted greenling feeds on small epibenthic crustaceans. Adult males are brightly colored and aggressive during the breeding season (DeMartini and Anderson 1980). They defend both a spawning site and a shelter hole, while females defend shelter holes only. The kelp greenling is also sexually dimorphic. This species feeds primarily on polychaetes, crustaceans, and small fishes (Feder et al. 1974). The kelp greenling is rare in southern California, and occurs in waters deeper than 20 m. The lingcod (Figure 22), a prized sport fish, is a seasonal migrant to kelp forests. Lingcod enter shallow waters to lay and guard eggs. Males guard nests for about seven weeks, and often guard two to four nests simultaneously. Their diet consists of crabs, cephalopods, and fishes (Miller and Geibel 1973). Some lingcod remain as residents of kelp forests, while others migrate to deeper waters.

Sculpins in the Family Cottidae are cryptic bottom fishes that can be very abundant, and difficult to see. A large member of this family, the cabezon, (Scorpaenichthys marmoratus) is often seen resting on the bottom and is easily approached. Cabezon are often caught by fishermen. The eggs are poisonous to humans and should not be eaten. This species feeds on crustaceans and molluscs, including abalone (O'Connell 1953, Feder et al. 1974). Other common subtidal sculpins include the lavender (Leiocottus hirundo) and the snubnose (Orthonopias triacis). They feed primarily on epibenthic crustaceans.

Gobies in the Family Gobiidae are small demersal fishes, often observed while scuba diving. The blackeye goby (Coryphopterus nicholsii, Figure 22) is usually observed in sandy areas near rocks. Nesting occurs from April to October, with the male first cleaning a spawning site under a rock. The female lays eggs, and the male guards the nest (Wiley 1973, Feder et al. 1974). The blue-banded goby (Lythrypnus dalli) is a

strikingly colorful fish common only in southern California. This species is brilliant crimson or orange-red with about six iridescent, blue, vertical stripes on the anterior two thirds of the body. Blue-banded gobies are omnivorous, but feed primarily on demersal zooplankton, especially amphipods (Feder et al. 1974). The zebra goby (Lythrypnus zebra) is a more cryptic species with similar coloration.

Within habitats, fish species may segregate by food supply. Hixon (1980) and Larson (1980a) provided the first experimental evidence that closely related species that occur in the bottom zone may partition space along a depth gradient in food availability. In each of two pairs of congeners, a competitively dominant microhabitat specialist excluded a subordinate generalist from the shallow zone where prey was more abundant. Predictably, the generalist expanded its distribution into shallow water when the specialist fish was removed by spearing. The specialist fish remained in shallow water in the absence of the generalist. Thus, bathymetric partitioning was maintained by interference competition.

#### 4.5.4 Other Species

An important predatory fish, the torpedo ray, (Torpedo californica; Figure 22), is most commonly observed in southern California. This species generally enters the kelp forest at night to feed on fishes, usually by initially shocking its prey, and then eating it whole (Bray and Hixon 1978). The torpedo ray hovers motionless above the bottom, apparently waiting for fishes to approach within its shocking range.

Sharks and rays, which are occasionally observed in kelp forests, include the bat ray (Myliobatis californica), the horn shark (Heterodontus francisci), the leopard shark (Triakis semifasciata), the angel shark (Squatina californica) and the swell shark (Cephaloscyllium ventriosum). Bat rays are usually found buried in sand or resting on rocks. They feed on shellfish such as abalone and turban and top snails (Feder et al. 1974), and may be seen grubbing for other prey in sand channels

between rocky reefs (Cowen pers. comm.). Horn sharks are frequently found in crevices or among rocks. They feed at night on large crustaceans and small fishes. The spiral-shaped egg cases are often scattered among rocks (Feder et al. 1974). Leopard sharks enter kelp forests for short periods, usually resting on the bottom. They eat crustaceans and small fishes. The angel shark buries in sand or mud, where it ambushes fishes such as corbina and queenfish (Feder et al. 1974).

Other occasional visitors to kelp forests include barracuda (*Sphyraena argentea*), Pacific bonito (*Sarda chilensis*), ocean sunfish or common mola (*Mola mola*), giant sea bass (*Stereolepis gigas*), the salema (*Xenistius californiensis*), and the jack mackerel (*Trachurus symmetricus*). Schools of barracuda and Pacific bonito enter kelp forests while pursuing anchovies or sardines (Feder et al. 1974). Ocean sunfish are weak-swimming pelagic fish that are swept into kelp forests via currents. Senoritas and kelp surferperch remove ectoparasites from ocean sunfish. Common molas lack teeth, and consume soft-bodied prey such as jellyfish and salps. The giant sea bass was once common in southern California, but its numbers have been severely decreased by overfishing. Individuals swim 2-3 m above the substrate, and feed on spiny lobsters, squid, and fishes (Feder et al. 1974). Salema and jack mackerel may form large schools in kelp forests during summer and early fall when the water is warmer.

## 4.6 BIRDS AND MAMMALS

### 4.6.1 Birds

4.6.1.1 Introduction. The association of birds with California kelp forests is poorly known, and is limited to generalized accounts. Due to the paucity of published literature, much of the discussion below will be based on personal communications.

North (1971b) does not include any birds in his list of the kelp bed fauna for southern California and northern Baja California, Mexico. However, he does mention birds as being top carnivores in the kelp community. Davis and Baldrige

(1980) acknowledged that seabirds often frequent kelp forests. Angell and Balcomb (1982) reported that the edges of Puget Sound, Washington kelp beds are "patrolled" by guillemots, auklets, and pelagic cormorants. Page et al. (1977) characterized the inshore bird assemblage as being made up of loons, grebes, cormorants, scoters, and pigeon guillemots. The only quantitative study of bird-kelp forest association is Hubbs et al. (1970), who documented the diet of Brandt's cormorants.

Kelp provides three distinct habitats used by birds:

1. Kelp Forest: Living, attached kelp in association with rocky substrata.
2. Drift Kelp: Detached kelp that may be found floating far out to sea in the pelagic zone.
3. Kelp Wrack: Detached kelp deposited on the beach by water motion.

The discussion below is organized by these habitats. Ashmole (1971) should be consulted for details of the feeding methods of the seabirds described.

4.6.1.2 Kelp forests. Kelp forests, with their associated invertebrates and fishes, provide a large potential food supply for birds. In addition, a well-developed kelp canopy reduces water motion, serving as a refuge from storms. From the standpoint of bird use, kelp forests can be conveniently divided into three somewhat distinct subhabitats: (1) the surface canopy; (2) the midwater and the bottom substrata beneath the canopy; and (3) the seaward fringe of the forest. The common birds in each subhabitat are listed in Table 10, and are discussed below.

Surface canopy. A well-developed canopy forms a buoyant mat on which birds may perch. The degree of canopy development is probably the most important factor in determining the numbers and diversity of birds that will be present. Seasonal variations in canopy development dictate the degree to which kelp forests will be utilized by birds.

Baldrige (pers. comm.) observed large numbers of elegant terns (*Sterna elegans*, Figure 23) and Heermann's gulls

Table 10. Birds of kelp forests and their subhabitat use.

Surface canopy	Midwater and bottom	Seaward fringe
Elegant tern ( <u>Thalasseus elegans</u> )	Pelagic cormorant ( <u>Phalacrocorax pelagicus</u> )	Brown pelican ( <u>Pelecanus occidentalis</u> )
Heermann's gull ( <u>Larus heermanni</u> )	Brandt's cormorant ( <u>Phalacrocorax penicillatus</u> )	Common loon ( <u>Gavia immer</u> )
Western gull ( <u>Larus occidentalis</u> )	Horned grebe ( <u>Podiceps auritus</u> )	Western grebe ( <u>Aechmophorus occidentalis</u> )
Bonaparte's gull ( <u>Larus philadelphia</u> )	Eared grebe ( <u>Podiceps caspicus</u> )	Brandt's cormorant ( <u>Phalacrocorax penicillatus</u> )
Great blue heron ( <u>Ardea herodias</u> )		Pelagic cormorant ( <u>Phalacrocorax pelagicus</u> )
Snowy egret ( <u>Leucophoyx thula</u> )		Surf scoter ( <u>Melanitta perspicillata</u> )
Willet ( <u>Catoptrophorus semipalmatus</u> )		White-winged scoter ( <u>Melanitta deglandi</u> )
Wandering tattler ( <u>Heteroscelus incanum</u> )		Pigeon guillemot ( <u>Cephus columba</u> )
Northern phalarope ( <u>Lobipes lobatus</u> )		Common murre ( <u>Uria aalge</u> )

(Larus heermanni) roosting on the kelp forest off Pacific Grove, California. Elegant terns inhabit California waters from July to November (Page et al. 1977). They pick small fishes from the canopy by surface plunging (Angell and Balcomb 1982).

Heermann's gulls, western gulls (Larus occidentalis, Figure 23), and Bonaparte's gulls (L. philadelphia) scavenge on the surface kelp canopy. On San Nicolas Island in southern California, western gulls pick the large grazing gastropod Norrisia norrisi from giant kelp canopies, and drop the snails on rocky ledges on shore. The impact breaks the thick shell so the gulls can then feed on the meat (Reed pers. comm.). Western gulls are year-round residents of California. Bonaparte's gull overwinters

in California, and Heermann's gull can be found in the summer and fall seasons (Page et al. 1977).

The great blue heron (Ardea herodias), and the snowy egret (Egretta thula) winter along coastal California, and can often be seen perched on the kelp canopy, frozen in motion, silently stalking prey at the water's surface (Figure 23). Occasional shorebirds such as the wandering tattler (Heteroscelus incanum), and the willet (Catoptrophorus semipalmatus) may forage on the surface of kelp forests (Baldrige pers. comm.). Jameson (pers. comm.) suggests that the heron feeds on juvenile rockfish and other small fishes in the canopy, egrets feed on isopods and kelp crabs, and willets on isopods. His observations also suggest that some of these birds may establish



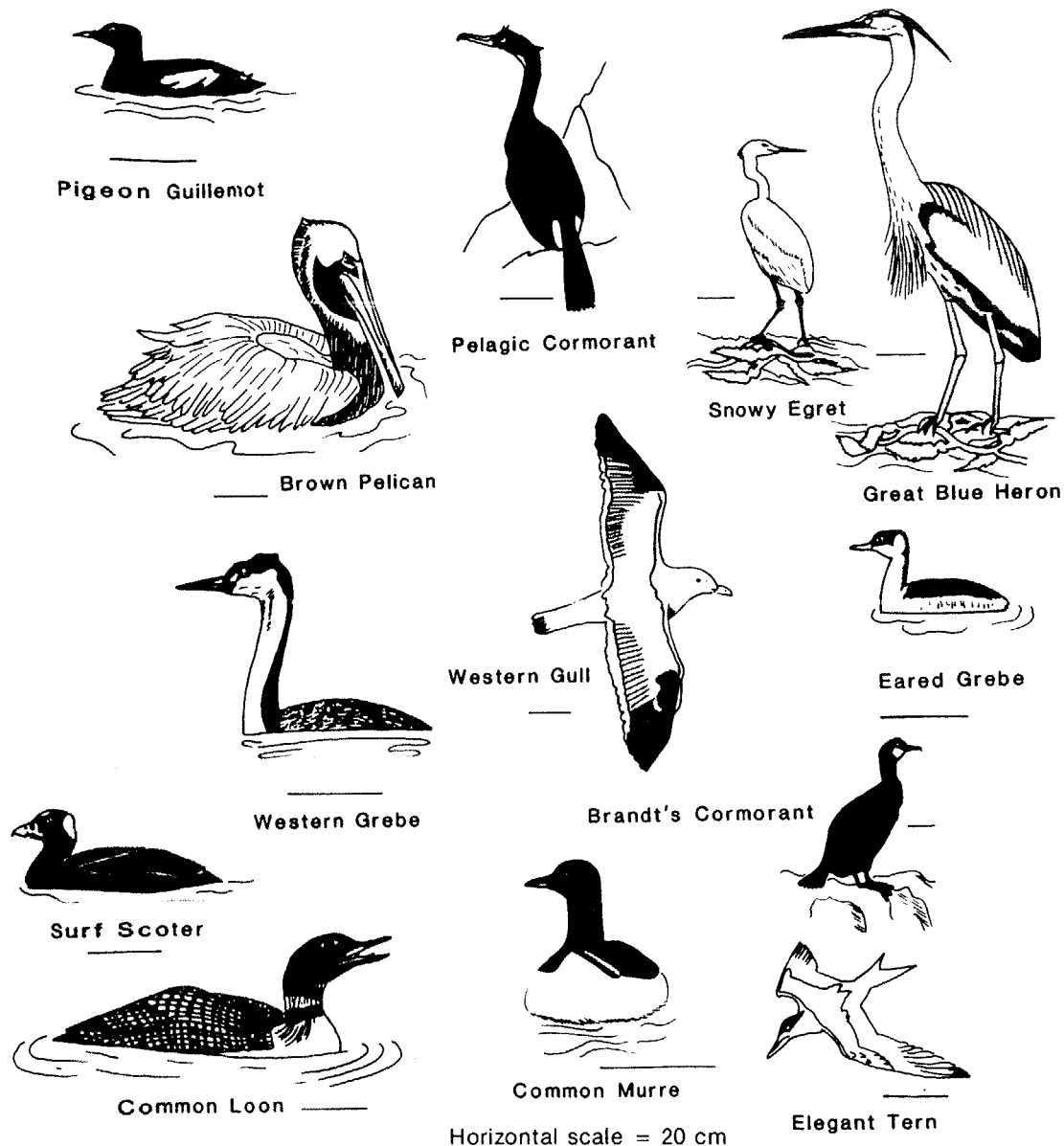

Figure 23. Birds commonly associated with kelp forests.

regular feeding territories in the canopy, particularly if freshwater feeding areas are limited.

While diving in kelp forests, Foster (pers. obs.) observed the northern phalarope (*Lobipes lobatus*) feeding on plankton within openings in the canopy. The common loon (*Gavia immer*, Figure 23), western grebe (*Aechmophorus occidentalis*, Figure 23), surf scoter (*Melanitta perspicillata*, Figure 23), and white-

winged scoter (*M. deglandi*) may also use California kelp forests with large open areas within the canopy (Baldrige pers. comm.).

Midwater and bottom. Of all the birds, the Brandt's cormorant (*Phalacrocorax pennicillatus*, Figure 23), and possibly the pelagic cormorant (*P. pelagicus*, Figure 23) are most closely associated with California kelp forests (Ainley pers. comm.). Hubbs et al. (1970)

described Brandt's cormorants in the vicinity of San Diego, California, as occupying a variety of habitats, but especially the large Macrocystis forest off La Jolla. Cormorants feed by foot-propelled pursuit diving but may also use their wings underwater (Cowen pers. comm.). The stomach contents of eight Brandt's cormorants from San Diego kelp forests revealed that they fed almost exclusively on fishes that inhabit the midwater among the fronds of Macrocystis (Hubbs et al. 1970). These included the seniorita (Oxyjulis californica), the blacksmith (Chromis punctipinnis), and the kelp perch (Brachyistius franatus) (see Section 4.5). The pelagic cormorant has similar feeding habits (Ainley et al. 1981). Both cormorants are year-round residents of California.

Ainley and Sanger (1979) included mysid shrimp as a major prey item of the horned grebe (Podiceps gurutus), and the eared grebe (P. niaricullis, Figure 23), two species that winter along the California coast. These small birds are foot-propelled pursuit divers, and are commonly observed within kelp forests (Baldrige pers. comm.). It is probable that they exploit the dense swarms of mysids found within the midwaters of the kelp community (see Section 4.2).

Seaward fringe. The fringe areas of kelp forests probably support the greatest diversity of birds. The interface between kelp and open waters often contains dense aggregations of invertebrates and fishes, perhaps because currents are reduced (see Section 2.2). The brown pelican (Pelicanus occidentalis californicus, Figure 23) along with terns (Family Laridae) are surface-plunging species that may exploit concentrations of schooling fishes along the canopy's edge. The loons (Family Gaviidae), grebes (Family Podicipedidae), cormorants (Family Phalacrocoracidae), and scoters (Family Anatidae) are all foot-propelled pursuit divers that may opportunistically forage along the edges of kelp forests.

Pigeon guillemots (Cephus columba, Figure 23) forage by wing-propelled pursuit, diving nearshore during spring, summer, and fall (Page et al. 1977). Angell and Balcomb (1982) reported that

pigeon guillemots dive for prey along the edges of kelp beds within the Puget Sound, Washington area. Follett and Ainley (1976) studied the diet of pigeon guillemots on Southeast Farallon Island, and found that they had fed upon 24 species of fish, the majority of which were benthic. Common murre (Uria aalge, Figure 23) also forage via wing-propelled pursuit diving, concentrating on open-water fish species and squid (Croll pers. comm.). They may also feed on the edges of kelp forests.

The majority of subsurface diving seabirds do not occur in the kelp canopy, but may be abundant at the canopy's fringe. With increased kelp density, subsurface diving may be restricted due to the possibility of entanglement of feet or wings (depending on the birds' mode of underwater locomotion).

4.6.1.3 Drift kelp. Plankton and small fishes often concentrate around drift kelp in pelagic waters. The red phalarope (Phalaropus fulicarius) and the northern phalarope (Lobipes lobatus) are found in California waters in summer and fall, and often feed in association with drift kelp far out to sea. Phalaropes are believed to feed by seizing planktonic organisms at the water's surface (Page et al. 1977). Seabirds may also use pelagic drift kelp as a roosting site (Keating pers. comm.).

4.6.1.4 Kelp wrack. Although some drift seaweed is usually found covering the intertidal zone in the vicinity of rocky areas, the export of large amounts of kelp to beach areas is a seasonal event associated with intense wave action from fall and winter storms. Beach drift can support a microcosm of invertebrates (kelp flies, fly maggots, beetles, various crustaceans, etc.) that are, in turn, available to birds as prey items (Yaninek 1980). A diversity of shore and terrestrial birds forage upon algal wrack on a seasonal basis (Davis and Baldrige 1980). Sanderlings (Calidris alba), black turnstones (Arenaria melanocephala), and ruddy turnstones (A. interpres), three opportunistically feeding shorebirds, regularly pick through kelp wrack. Common crows (Corvus brachyrhynchos), starlings (Sturnus vulgaris), and brewer's

blackbirds (Auphagus cyanocephalus) dig through beach-cast wrack in search of marine invertebrates and insects, and the latter also catch beach flies. Beds of decomposing kelp along central and southern California beaches attract black phoebes (Sayornis nigricans), house sparrows (Passer demesticus), and yellow-rumped warblers (Dendrioca coronata) that feed on flies and other insects (Davis and Baldrige 1980).

Jameson (pers. comm.) also observed a variety of birds feeding on drift-associated invertebrates, and in the case of physically unstable cobble beaches, he pointed out that this drift can change an otherwise food-poor habitat into a rich feeding area for birds. He noted intense nearshore feeding by gulls around partially decomposed drift when the drift is moved back into the water during high tides or storms, and suggests that the gulls may be eating amphipods exposed when the drift breaks up.

Ainley (1976) states that "...marine biologists as a general rule ignore birds." This viewpoint is confirmed in the case of bird-kelp interactions and, as further indicated by the considerable speculation in this section of the profile, much remains to be learned about the relationship between kelp forests and nearshore bird populations.

#### 4.6.2 Marine Mammals

4.6.2.1 Introduction. The sea otter, gray whale, killer whale, harbor seal, and California sea lion (Figure 24) are listed (North 1971a) as the mammals associated with the kelp forests of southern California and northern Baja California, Mexico, although the sea otter does not presently occur south of Point Conception (Figure 8). All of these mammals do occur associated with Macrocystis pyrifera and Nereocystis luetkeana along the central California coast.

The sea otter (Enhydra lutris) exhibits the closest association with kelp forests, potentially inhabiting the kelp surface canopy and foraging throughout the water column during its entire life. Gray whales (Eschrichtius robustus) are

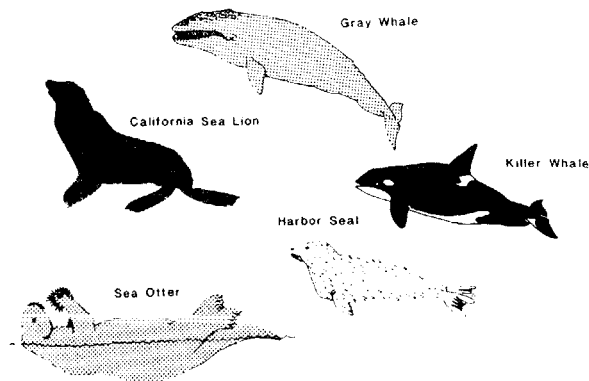

Figure 24. Marine mammals associated with kelp forests.

commonly seen offshore from kelp forests during their migrations along the coast, and have been observed to feed on mysid shrimp associated with the kelp. The relationship of California sea lions (Zalophus californianus) and killer whales (Orcinas orca) to kelp forests is probably limited to transitory foraging excursions in the kelp. Harbor seals (Phoca vitulina) are frequently seen in kelp forests and feed on a variety of kelp forest fishes.

The size of gray whale and sea otter populations in the northeast Pacific was drastically reduced by the early part of this century due to human exploitation. Historical accounts of the aboriginal and commercial exploitation of sea otters can be found in Kenyon (1969); those of gray whales in Rice and Wolman (1971). Enactment of protective legislation for otters in 1911, and for gray whales in 1972, has been instrumental in the dramatic recovery of both populations. As these animals have increased in numbers and begun to inhabit portions of their ancestral range, their respective roles in the ecology of the kelp forest community, particularly that of the sea otter, are being elucidated.

4.6.2.2 Sea otter (Enhydra lutris). In California, the preferred habitat of the sea otter is a lush kelp canopy in proximity to rocky substrata with deep crevices (Woodhouse et al. 1977). Kelp forests dampen wave action, creating areas of calm that serve as otter refuges from

winter storms. The forests may also serve as protection from predators such as white sharks. If kelp surface canopies are present, otters sleep in them, and are often observed with strands of kelp draped over their bodies, presumably to prevent movement (Kenyon 1969). Jameson's (pers. comm.) current studies on sea otter behavior have also shown a close association between sea otters and kelp. Otters are most commonly found in protected inshore kelp canopies in central California in winter, when storms remove canopies in deeper water. Otters gradually move out into the offshore canopies as these reform in spring and summer. After the extreme winter storms of 1982-83, Jameson (pers. comm.) observed that most otters along the shore near San Luis Obispo were inhabiting the few small, shallow stands of giant kelp that remained; we observed similar behavior in Carmel Bay.

Kelp forests also function as a nursery area for females with pups. Sandegren et al. (1973) postulated that females give birth to pups while in the water. Jameson (1983) discovered a mother-pup pair hauled-out on land minutes after the pup had apparently been born. He hypothesized that sea otters give birth in kelp forests whenever possible. When kelp surface canopies are unavailable, however, birth may be accomplished on land. In heavy seas, pups use kelp strands as anchors while females forage. During winter storms in central California when the kelp canopy is reduced, increased competition between mother-pup pairs may occur for space in the available canopy (Sandegren et al. 1973).

The diet of sea otters in kelp forests consists of epibenthic invertebrates commonly associated with low intertidal and subtidal rocky substrata with deep crevices (e.g., sea urchins, abalone), and with kelp fronds (e.g., *Tegula* spp., kelp crabs; see review in Woodhouse et al. 1977, Estes et al. 1981). Otters forage at depths to 40 m, securing their prey with their forepaws, and returning to the surface to eat (Kenyon 1969). California sea otters display a unique type of tool-using behavior when feeding on hard-shelled invertebrates: food items may be pounded against a rock

held on the otter's chest while floating at the water's surface (Fisher 1939). Houk and Geibel (1974) described an incident of a sea otter, underwater, pounding an attached abalone with a rock.

Costa (1978) calculated that an average-sized otter must consume 25% of its body weight daily to meet its energy needs. Ostfeld (1982) studied the foraging "strategies" of a colonizing group of otters in a *Macrocystis* forest off Point Santa Cruz, California. Initially, red sea urchins were the otter's major prey item. Kelp crabs and clams replaced urchins as major prey items as urchins became increasingly scarce. Abalone and cancer crabs were consistently exploited as dietary items at relatively low levels. Other rocky substrata prey items include snails, mussels, octopus, chitons, tubeworms, limpets, barnacles, scallops, and starfish (Ebert 1968, Wild and Ames 1974, Shimek 1977, Woodhouse et al. 1977, Estes et al. 1981). Van Wagenen et al. (1981) observed sea otters preying on seabirds.

Otters are able to adapt to diverse environments (Woodhouse et al. 1977). The spreading fronts of the California population have successfully occupied sandy and silty bottom coastal zones, exploiting Pismo clams, gaper clams, razor clams, mole crabs, and even echiuroid "worms" as prey (Wild and Ames 1974, Stephenson 1977, Hines and Loughlin 1980). Outside the protection of the kelp canopy, the sea otter is susceptible to attacks by the great white shark (Ames and Morejohn 1980). Other than man and parasites, this shark is its only known predator in California waters.

Before commercial exploitation, the range of the sea otter extended in a continuous arc from the northern islands of Japan, along the Kamchatka coastline, across the Aleutian Islands chain, and southward along the west coast of North America into lower Baja California, Mexico (Kenyon 1969). The population southeast of the Aleutian chain was believed to be extinct until the discovery in 1938 of a raft of 50 to 90 individuals along the central California coast (Bolin 1938, Woodhouse et al. 1977). After legal protection was afforded, the range of the

sea otter extended at the rate of approximately 4 km annually, with a total population increase of 5% per year until recently (Wild and Ames 1974). Presently, a population of approximately 1,300 individuals occupies a range extending 320 km along the California coast from Point Sal, San Luis Obispo County, to Point Santa Cruz, Santa Cruz County (Estes and Jameson 1983). However, there has been no apparent increase in population size since the late 1960's (Estes and Jameson 1983). The incidental entanglement of otters in commercial fishing gear, particularly gill and trammel nets, may be partly responsible for the present stabilization in population size (Keating pers. comm.).

Kelp distribution and abundance can be limited by sea urchin grazing (see Sections 4.4.3.1 and 5.5.3); numerous investigators (Booolootian 1961, Ebert 1968, Benech 1980, Ostfeld 1982) have observed otters colonizing kelp forests in central California to prey preferentially on red sea urchins and abalone. Estes and Palmisano (1974) asserted that sea otters, by their removal of sea urchins, will have a profound effect on the structuring of nearshore communities. Where sea otters forage over rocky substrate, sea urchin densities will decrease, and if sea urchins were limiting algal growth, a subsequent increase in macroalgal biomass will result. However, Cowen et al. (1982) caution that the sea otter's influence should not be generalized as the dominant factor structuring giant kelp communities in California. In their study area, physical factors, particularly water motion due to winter storms, had a greater effect than the removal of urchins on a nearshore kelp community. A variety of factors (storms, grazing, other predators, recruitment events, etc.) may have significant effects on giant kelp community structure (Foster 1982a; see Chapters 3 and 5), and generalizations about the great importance of the sea otter-sea urchin interaction, based on studies in other geographic areas or in sites disturbed by man in southern California, may not apply to the heterogeneous California coast (see also Chapter 5).

4.6.2.3 Cetaceans. Gray whale  
(Eschrichtius robustus). Gray whales

migrate yearly from their summer feeding grounds in the Bering and Chukchi Seas to their winter breeding grounds along the coast of Baja California, Mexico. Each leg of the journey encompasses approximately 10,000 km, and takes between 2.5 and 3 months (Rice and Wolman 1971). In both the southern and northern phases of the migration, gray whales pass within a few km of the California coastline.

Scammon (1874) noted that gray whale cows with their calves swim very close to shore on their northern migration, often passing through kelp beds. During the era of active whaling in California (late 1800s to 1969), cow-calf pairs were observed only rarely on their northern migration, and were thought to use a more distant offshore migrational route than solitary whales (Rice and Wolman 1971). As populations have increased, Poole (in press) has reconfirmed Scammon's observation that cow-calf pairs undertake a nearshore northern migration route, while individual males and females travel a point-to-point offshore route. Cow-calf pairs pass along the central California coastline in April and May, 2 months later than solitary whales. They migrate along an inshore route 200 to 400 m from shore, and are often sighted along the outer edges of kelp forests, or within the kelp canopy itself.

Poole (in press) recognizes two possible advantages gained by cow-calf pairs utilizing a nearshore route that passes near kelp communities. First, kelp forests may provide protection from predation by killer whales. Baldrige (1972) described in detail the attack of a pod of killer whales on a cow-calf pair near a kelp forest off Carmel, California. The reaction of the cow and calf to the attack was to seek refuge in a nearby kelp forest. The killer whales cut off the calf's retreat into the kelp. The calf was subsequently killed, but the cow escaped into the kelp.

Kelp forests may also provide potential food for the nursing cow. Gray whales feed primarily on benthic gammarid amphipods found in great abundance in their Arctic feeding grounds. It is generally accepted that gray whales do not feed while migrating or during their

occupation of breeding areas in Baja California, Mexico (Rice and Wolman 1971; Oliver et al. 1983). However, there is now evidence that gray whales, while migrating, feed on dense swarms of mysid shrimp within or along the outer edges of kelp beds and forests (Wellington and Anderson 1978, Poole in press, Murison et al. in press). It may be advantageous for a gray whale cow with a dependent calf to supplement her stored reserves by feeding upon the abundant mysid resource associated with kelp (Poole in press).

Killer whale (*Orcinus orca*). The status and distribution of the California population of killer whales are not known (Morejohn 1977). Killer whales feed in small groups in nearshore regions, particularly near areas of high marine mammal concentrations (e.g., pinniped rookeries; Rice 1968). Pods of killer whales have been sighted traveling along the edge of kelp forests (Daugherty and Schuyler 1979).

4.6.2.4 Pinnipeds. Harbor seal (*Phoca vitulus*). Harbor seals are year-round residents of embayments, sloughs, and rivers along the California coast, with an estimated population of 20,000 individuals (Miller pers. comm.). Jones (1981) describes the diet of harbor seals as consisting of shallow-bottom fishes that live near rock habitat, but they also feed on pelagic fishes in many areas (Estes pers. comm.). Greenlings and surfperch, two common groups of kelp forest fishes (see Section 4.5), were included by Jones as major prey items. Daugherty and Schuyler (1979) pointed out that harbor seals resting in thick beds of kelp with their heads protruding above the surface are often mistaken for sea otters. Although we could locate no specific reference to the harbor seal's association with kelp beds, individuals are commonly observed while diving in kelp and probably forage extensively in kelp forests when these habitats are close to seal haul-out areas. Jameson (pers. comm.) has even observed a harbor seal partially hauled-out on a dense, floating canopy of *Nereocystis luetkeana*.

California sea lion (*Zalophus californianus*). The California sea lion breeds on the Channel Islands of southern

California, along the coast of Baja California, Mexico, and in the Gulf of California during June and July. During the remainder of the year, some 75,000 sea lions (Bonnell pers. comm.) inhabit the entire coastal region of California. Groups of sea lions are sometimes seen passing through kelp forests or foraging along the kelp forest fringe. Sea lions show a preference for pelagic prey items (Jones 1981). It is probable that the association of sea lions with kelp forests is limited to transitory foraging, although these animals are commonly observed in kelp forests by divers.

4.6.2.5 Steller's sea cow (*Hydrodamalis gigas*). Giant kelp forests were, in the past, probably also inhabited by the now-extinct Steller's sea cow. This huge (6,000 kg, over 7 m long; Domning 1978) herbivorous mammal is believed to have inhabited nearshore areas from Baja California, Mexico, to Russia. Probably as a result of hunting by aboriginal man, only an estimated 2,000 animals remained in the remote portions of the western Aleutian Islands and eastern Russia by 1741, and the last animal is believed to have been killed in 1768 (Domning 1978).

*Hydrodamalis gigas* apparently did not completely submerge, and fed on various seaweeds and sea grasses in very shallow (probably 1-2 m) water (Domning 1978). Its shallow subtidal habitat, lack of diving, and slow movements made this sirenian easy prey for hunters. Dayton (1975) suggested that sea cow grazing may have been important in the evolution of algal assemblages in kelp forests. However, given what is known of the sea cow's habitat and method of feeding, this is arguable. Although apparently never observed, sea cows could have fed on surface canopies in deeper water.

## 4.7 DISEASES

### 4.7.1 Introduction

A variety of pathogens and parasites infect macro-organisms in giant kelp forests, but except for a limited number of cases reviewed below, little is known of their effects on host populations.

#### 4.7.2 Macroalgae

Andrews (1977) and Goff and Glasgow (1980) recently summarized information on seaweed pathogens, and the latter publication is a particularly comprehensive account. Perhaps the most notorious disease is "black rot" of Macrocystis, which is visible as dark areas on the margins of the blades. These become lesions, and the blades eventually disintegrate. The symptoms may occur throughout large kelp stands, suggesting that the disease may cause large-scale loss of plants (ZoBell 1946). Scotten (1971), however, could not find evidence of a bacterial or fungal cause, and suggested that black rot is not caused by a pathogen, but may simply be deterioration associated with elevated water temperatures. Dean (pers. comm.) observed extensive black rot and numerous sinking fronds in southern California kelp forests in October 1983, coincident with the warm water associated with the current "El Nino" (see Section 2.3).

Recent observations of adult Macrocystis pyrifera isolated in a large container at Santa Catalina Island revealed another potential disease (Gerard pers. comm.). Blades (especially those near the holdfast) growing in warm, high nutrient water developed numerous small holes and eventually deteriorated. Dean (pers. comm.) noted similar symptoms in small Pterygophora californica off San Onofre in 1983. The symptoms in Macrocystis led to the tentative name of "shot hole disease," but the cause is unknown. However, just as in monocultures of terrestrial plants, the common occurrence in culture of this hitherto rarely observed symptom suggests that other unanticipated problems with disease may occur in future attempts to isolate Macrocystis in culture (see Goff and Glasgow 1980 for a review of pathogens in other currently-cultivated seaweeds).

Macrocystis as well as other macroalgae are inhabited by a diverse group of potential pathogenic organisms such as nematodes, algal and animal epigrowths, algal parasites, bacteria, and fungi. Plants may be found with tumors and galls (Andrews 1977, Goff and Glasgow 1980). Few of these have been observed to

cause severe damage to individuals in kelp forests, and none has been observed to cause damage to populations.

#### 4.7.3 Invertebrates

Invertebrate pathogens and parasites are also common, and some have significant impacts on populations. Pearse et al. (1977) reported a mass mortality of red sea urchins (Strongylocentrotus franciscanus) near Santa Cruz, and reviewed other occurrences of this phenomenon in California. When affected, the urchins' spines are no longer held upright and are eventually lost, the epidermis degenerates, and the animal dies. Similar symptoms and widespread mortality have occurred recently in sea urchin populations in Nova Scotia (Miller and Colodey 1983). The cause of the disease in California is unknown; a protozoan may be the cause in Nova Scotia (Miller and Colodey 1983). If sea urchin grazing limits kelp distribution, then such a disease can ultimately result in kelp forest enlargement, as it did at the site near Santa Cruz (Pearse and Hines 1979), and as it is doing in Nova Scotia (Pearse pers. comm.). Observations in these and other areas suggest that disease may be an important factor in the regulation of sea urchin populations (Pearse pers. comm.).

Mortality of other echinoderms, particularly the bat star (Patiria miniata) has been observed in southern California, both along the mainland (Schroeter and Dixon pers. comm.) and at San Nicolas (Harrold pers. comm.) and Santa Catalina Island (Gerard pers. comm.). Similar mortality has occurred in the Gulf of California (Dungan et al. 1982). When the water is abnormally warm, bat stars become covered with a white, mold-like film and eventually die. Affected bat stars that fell down steep slopes into colder water at Santa Catalina Island apparently recovered. Schroeter et al. (1983) have shown that P. miniata predation may significantly alter the distribution and abundance of white sea urchins (Lytechinus anamesus), and feeding by the star may also significantly affect other populations, including plants (see Section 4.4.3 above). Bat star populations have been nearly destroyed by

disease in one kelp stand in southern California (Schroeter and Dixon pers. comm.), so this disease, like that affecting sea urchins, may have important community effects. The cause of the disease is unknown.

The third cause of death is associated with dinoflagellate blooms (red tides). Death in this case may result from oxygen reduction when the dinoflagellates decomposed. Fay et al. (1972) stated that "fish, lobsters, and other marine life" have been killed during particular red tides in southern California, and similar observations have been made at least once in central California (Laur pers. comm.). The effects of these losses on other organisms in the kelp community are unknown.

#### 4.7.4 Vertebrates

Fishes are affected by a number of diseases, including the dinoflagellate toxins above, but the widespread occurrence of tumors, lesions, and fin rot has been particularly common in nearshore areas around large ocean sewer outfalls near Los Angeles. Cross (1982) found that 11% of fishes caught in otter trawls in this area had fin rot. However, this represented a decline from previous percentages, a decline coincident with the reduction in chlorinated hydrocarbons, heavy metals, and organic matter discharged from the sewer. The incidence

of tumors and other diseases of fishes in this region is discussed by Mearns and Sherwood (1977).

Various parasites occur in kelp forest fishes but the population consequences of their activities remain largely unknown. Some of these parasites, especially certain roundworms, can be harmful to man if infected fish are eaten raw. Moser and Love (1978) reviewed parasites of marine fish in California, and suggested methods for detecting and destroying those harmful to man.

Parasites may harm fishes, but they can also be used to study fish movements. Some fishes with limited movements may show higher incidences of a particular parasite in local populations. Love (1980) used such a parasite "tag" in his innovative study of movements of the olive rockfish (see Section 4.5 above). He found that this rockfish moved little between reefs; thus a particular reef can be easily overfished.

Numerous animals parasitize marine mammals (see Dailey and Brownell 1971 for review). The sea otter, most commonly associated with kelp forests (see Section 4.6.6.2 above), has a number of acanthocephalan parasites (Hennessy and Morejohn 1977). While individual animals may be seriously affected by some parasites, these authors concluded that effects on the sea otter population in California are small.





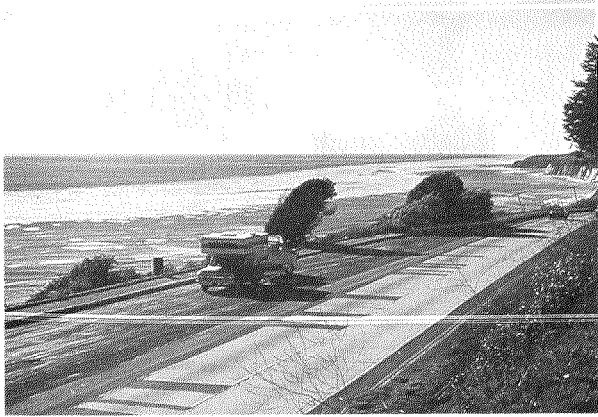

Plate 1A. Macrocyctis surface canopy near Santa Barbara.

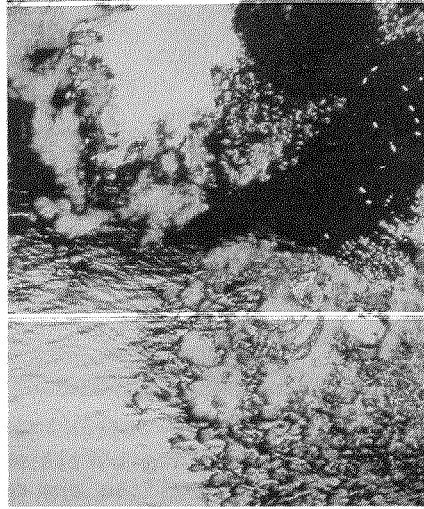

Plate 1B. Infra-red aerial photograph of Macrocyctis (orange) canopy in Carmel Bay (courtesy California Department of Fish and Game).



Plate 1C. Macrocyctis forest with numerous fish beneath the surface canopy (courtesy D. Reed).

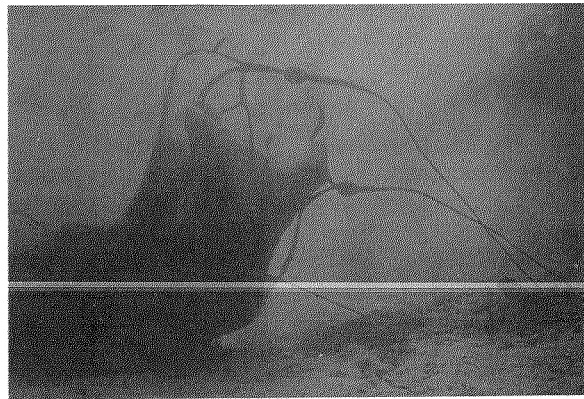

Plate 1D. Pelagophycus porra at Santa Catalina Island.



Plate 1E. Understory canopy of Pterygophora californica (courtesy S. Pace).

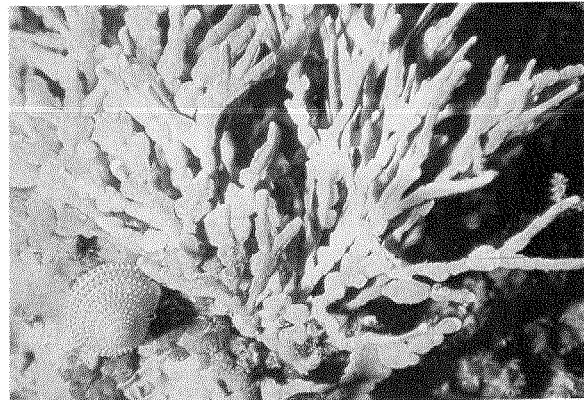

Plate 1F. The articulated coralline alga Calliarthron, and the purple-ringed top shell, Calliostoma annulatum.

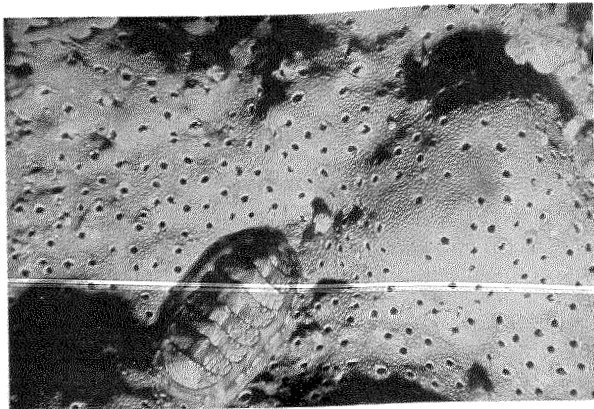

Plate 2A. The lined chiton Tonicella lineata, on an encrusting coralline alga. Dark spots on the coralline are openings to polychaete tubes.

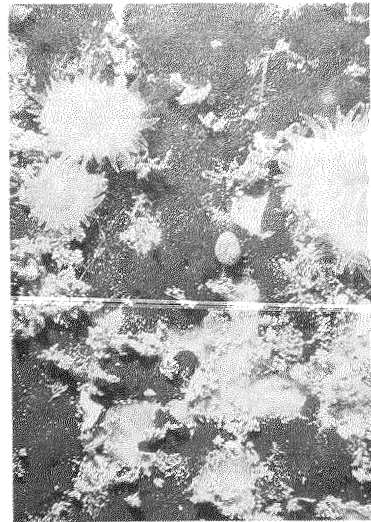

Plate 2B. Cup corals and the cobalt sponge Hymenamphiastra cyanocrypta.

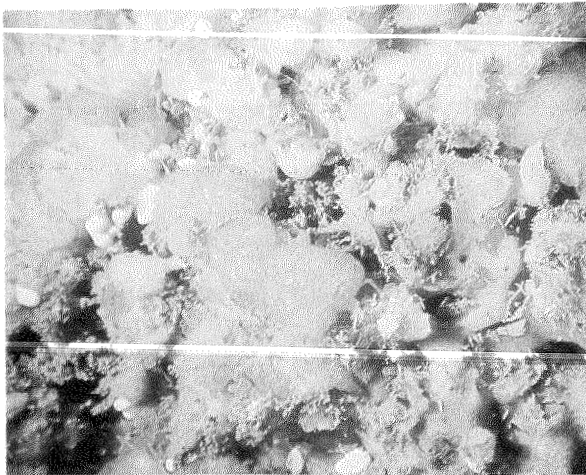

Plate 2C. Various tunicates and sponges on a vertical wall within a kelp forest.

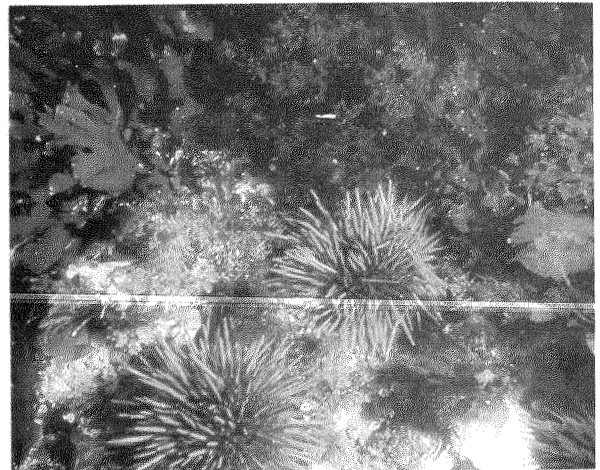

Plate 2D. Red sea urchins surrounded by various foliose red algae.

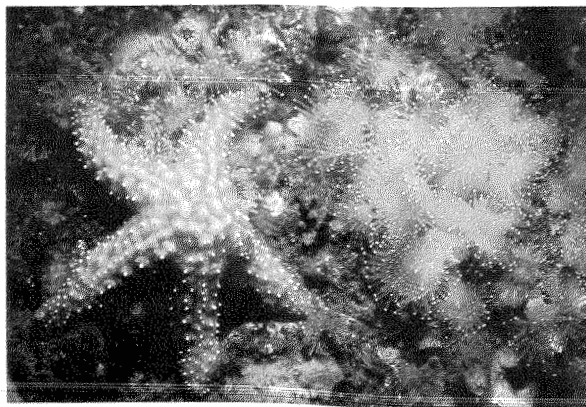

Plate 2E. Pisaster giganteus and a group of strawberry anemones, Corynactis californica (courtesy S. Webster).

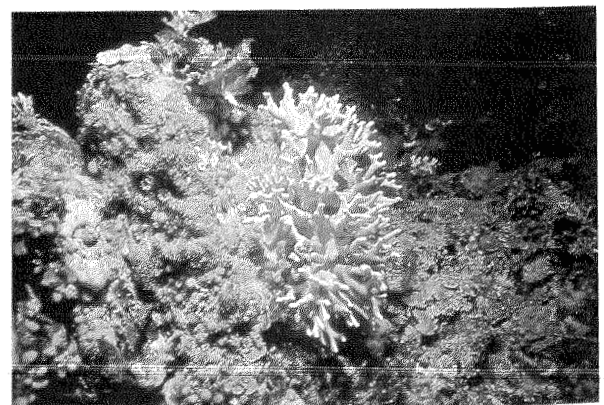

Plate 2F. The hydrocoral Allopora californica (courtesy S. Webster).

## CHAPTER 5

### HYPOTHESES CONCERNING COMMUNITY STRUCTURE AND DYNAMICS

*The ecosystem must first be accurately described using proper methods of sampling and measuring the relevant environmental variables. Once this is done, the ecologist looks for patterns of correlation between the distribution and abundance of the different organisms and their abiotic environment. By asking questions about the causes of the patterns, answers suggest themselves which can be formulated as testable hypotheses. Then experiments can be designed to test these hypotheses. Connell (1974).*

#### 5.1 INTRODUCTION

Previous chapters have been primarily descriptive, discussing various biotic and abiotic factors associated with the distribution and abundance of *Macrocystis* and other organisms in giant kelp forests. The availability of light, nutrients, and suitable substrata, temperatures and water motion put broad limits on where kelp forests might occur, but they reveal little about the mechanisms and interactions which structure these types of communities. In many cases, subtidal workers have substituted a rubber diving suit for the tweed coat and gumboots of the early intertidal natural historian, attempting to describe habitats and the organisms present in terms of associations and observed patterns. Only in relatively recent times has the technology of SCUBA diving allowed researchers to explore subtidal communities in a routine fashion, permitting them to identify the factors and patterns that form the basis of experimentally testable hypotheses. Consequently, there are only a few published accounts of studies that have tested for the processes that affect the

distribution and abundances of kelp species, and fewer still that assess the interactions of factors.

Putatively important processes such as competition and grazing (= predation of plants by animals) may have strong effects in some places, at some times. The interactions between kelps and other organisms may have different effects at various stages of the life cycles of plants (Figure 25). The abundances of individual species change along a depth gradient, which may affect the intensity of interactions. Analyses of many of these problems are now tractable experimentally.

A critical examination of the methods used to assess the important processes that structure communities is not unique. Currently, there is much debate about the importance of competition in terrestrial and marine intertidal communities: when and where is competition important, or does it even occur at all in many situations (Connell 1983; Simberloff 1983; see *American Naturalist* 1983, 122(5))? When and where is predation important? Methodological problems have been

**The Gauntlet of *Macrocystis* Microscopic Stages**  
 will be affected by light, water, motion, etc., that vary with season

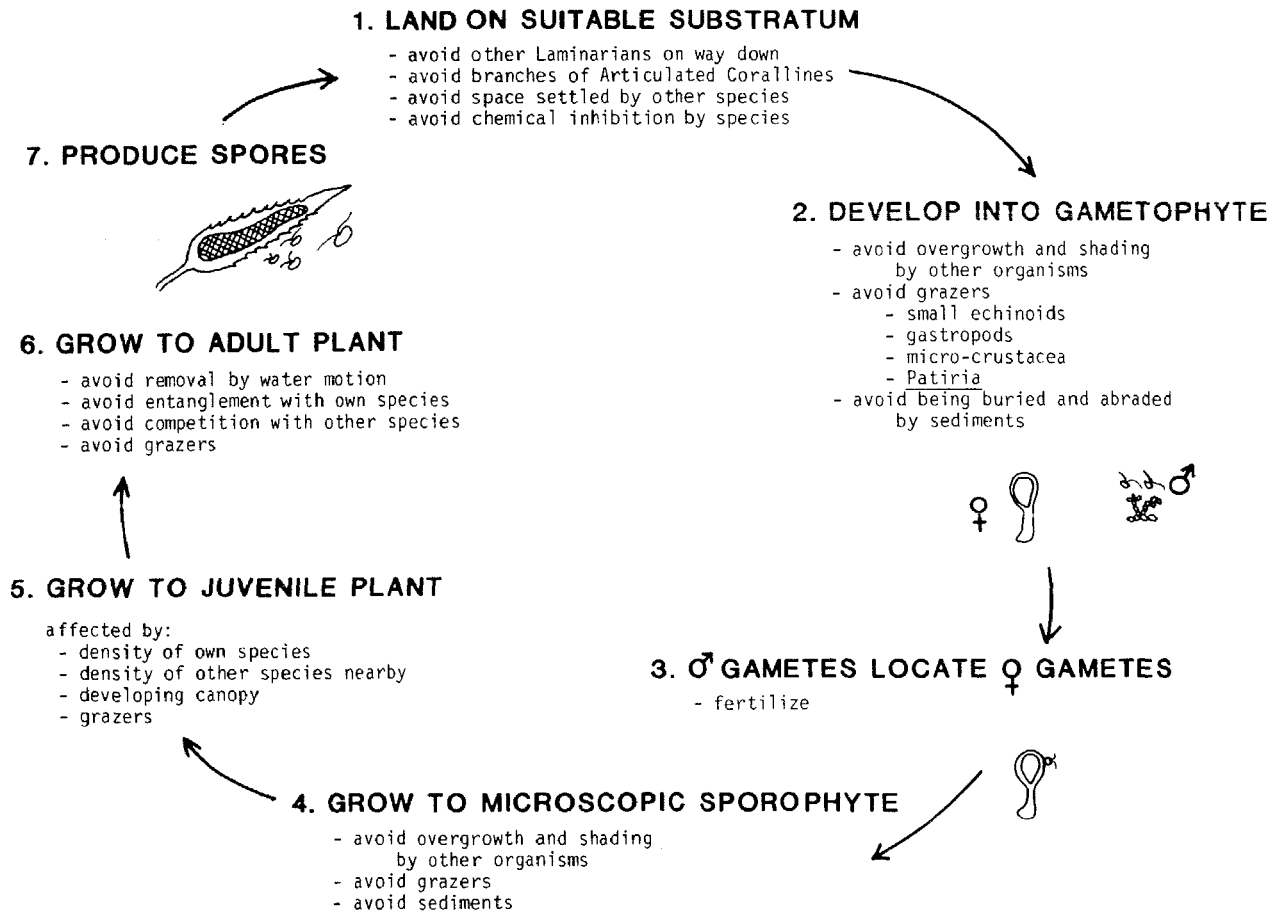

Figure 25. The gauntlet of *Macrocystis* life history stages. Survival will also be affected by physical/chemical factors that vary in time.

discussed, along with interesting and innovative approaches to experimental studies (e.g., Underwood and Denley 1984; see Strong et al. 1984). This debate is particularly germane to subtidal studies, which are in a relatively early stage of experimental work.

This chapter focuses on the questions asked and the hypotheses proposed concerning the distribution and abundance of *Macrocystis*, the studies that have examined them, and the evidence for their importance. Some of the studies mentioned earlier in this review are more critically examined for details of experimental

design and the conclusions based on them. Figure 26 outlines the factors commonly cited as affecting one or more of the life history stages of this species. Several spatial and temporal scales are also listed. Not all of these hypotheses are presently capable of being assessed experimentally in the field. Much of this will require innovative techniques and methods (for review of current methods, see Foster et al. in press).

Most subtidal researchers are logistically constrained to working at relatively local sites along one area of coastline, and usually over a short time

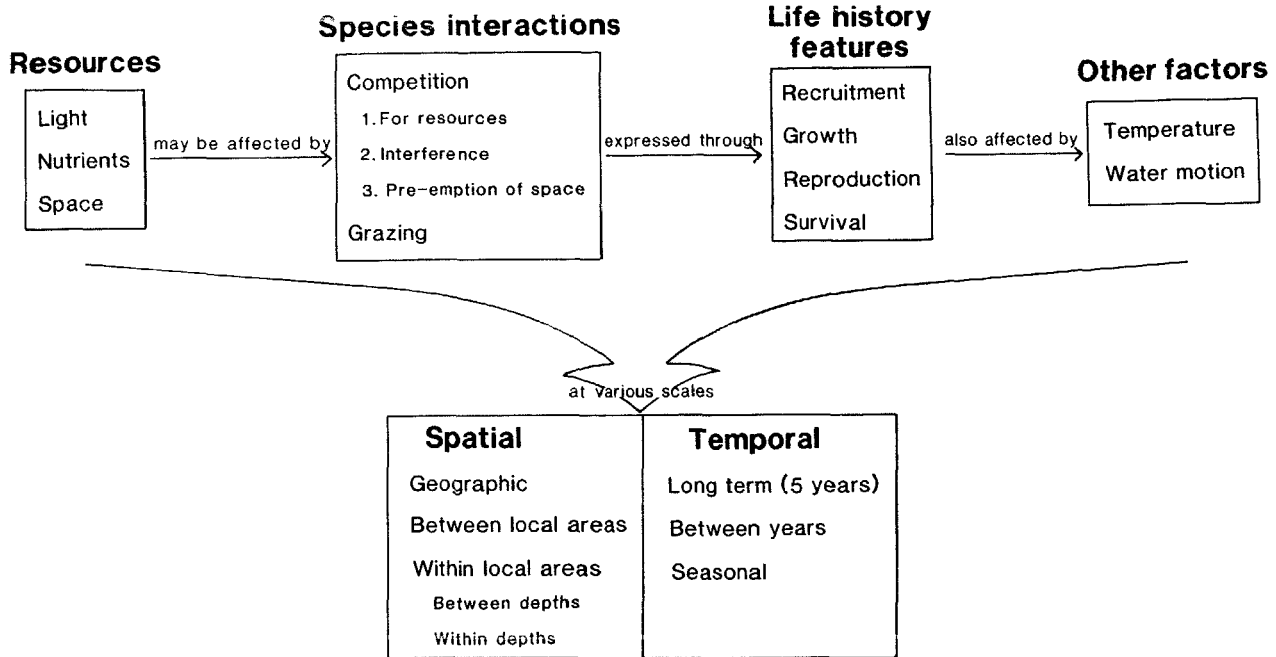

Figure 26. Summary of important features of kelp forest dynamics and the temporal and spatial scales at which they occur.

scale of a few years at most. The large prominent surface canopy of *Macrocystis pyrifera* has tended to obscure the variability of the communities it dominates at local sites. Kelp forests, however, may be as variable within areas as they are among different areas along a coast (Rosenthal et al. 1974, Foster et al. 1983; see Chapter 3). Experimental studies of the factors producing variability between and within sites are possible on relatively restricted spatial and temporal scales.

Finally, an examination of experimental studies involving kelp abundances and distribution shows that in most cases only one factor has been assessed, in one place, at one time. Factorial experiments are necessary to test the relative importance of factors, their interactions, and unaccounted for variability. Many more areas will have to be examined before any generalizations assume validity. In addition, many studies suffer from pseudoreplication (inferential statistical testing using subsamples from within one "experimental" plot and one "control" plot; Hurlbert

1984). Replication of treatments and sites within each area is a powerful means of assessing local variability (Hurlbert 1984). We do not go into the details of experimental design and sampling, but suggest Underwood (1981), Hurlbert (1984) and Green (1979) for good discussions of these.

## 5.2 EFFECTS OF TEMPERATURE

General hypothesis: The distributional range of *Macrocystis* is limited by its inability to survive higher temperatures (ca. 20 °C) and by the inability of gametophytes to become fertile at lower temperatures (ca. 5 °C).

The most common explanation for limits to the geographical distributions of large algal species is their susceptibility to temperature. Susceptibilities can occur at several stages in the life histories of plants. The topic has been extensively reviewed by Van den Hoek (1982) and is discussed in Section 2.3. This reference states that at least six different boundaries can be postulated:

(1) the "northern lethal boundary" corresponding to the lowest winter temperature at which a species can survive; (2) the "northern growth boundary" corresponding to the lowest summer temperature which, over a period of several months, permits sufficient growth for plant maintenance; (3) the "northern reproductive boundary" corresponding to the lowest summer temperature permitting reproduction over a period of several months; and (4-6) the corresponding southern boundaries.

These boundaries have not all been investigated for *Macrocystis pyrifera* on the west coast. The lethal southern boundary for adult *Macrocystis* in California is thought to be where 20°C temperatures persist for at least two weeks (North 1971b). An established population of *Macrocystis* off San Diego deteriorated during such a period. The southernmost population of *Macrocystis* off Baja California, Mexico is, however, subject to higher temperatures, and yet has generally persisted. This highlights some of the problems in determining tolerances of individual species. Some populations and some individuals will be more tolerant than others to environmental stresses. Nevertheless, Van den Hoek (1982) found broad correlations between species tolerances along the coasts of the Atlantic Ocean and their distributions along isotherms for those tolerances.

Because of the variability in community composition among sites, it is clear that testing for the effects of temperature on geographic limits of species can only be done indirectly. Two approaches are possible: (1) laboratory-based studies on tolerances, growth rates, germination and survival of gametophytes and young sporophytes; and (2) transplant experiments of gametophytes and sporophytes into similar habitats at localities with different temperature regimes.

The main problems confronted in comparing geographic localities are that there are usually large differences in biotic factors such as the presence of other algal species and grazers (see Chapters 3 and 4), and also that temperature, nutrients, and light are often correlated (Jackson 1977). It is

difficult to separate these factors in the field, but it is relatively straightforward to measure them. Dean et al. (1983) and Dean and Deysler (1983) made continuous measurements of temperature and irradiance in the San Onofre kelp forest in southern California. They found that temperature and irradiance were positively correlated (Figure 27). Successful natural recruitment of

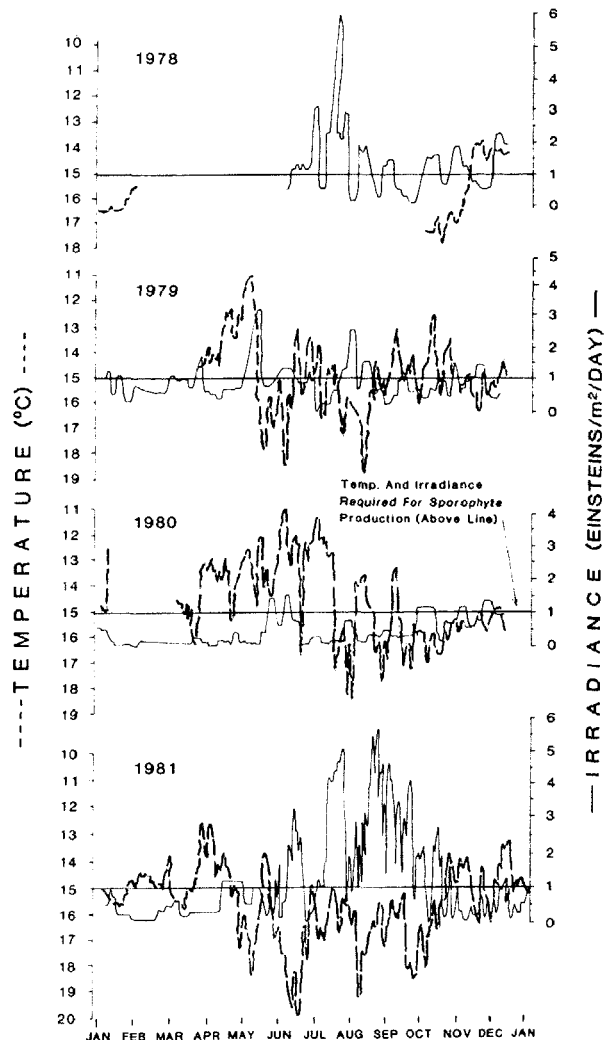

Figure 27. Temperature and irradiance recorded on the bottom in a *Macrocystis* forest over a 4-year period. Lab and field studies indicate that *Macrocystis* will successfully recruit only when both temperature and irradiance are above the solid line. Note that temperature decreases going up the vertical scale (from Dean et al. 1983).

Macrocystis sporophytes was observed on only four occasions between 1977 and 1981. These episodes coincided with four of the eight periods when temperatures were at or below 16.3°C, and irradiance levels were at or above 0.4 E/m<sup>2</sup>/day. This study indicates that temperature and light are interactive, which may have relevance for geographic distributions. This is similar to conclusions of laboratory studies of Luning (1980) for species of Laminaria. Appropriate measurements of light and temperature have not been done in tandem with recruitment, growth, and survivorship studies in other localities. Such studies, along with a thorough evaluation of the biological differences among sites, would provide important evidence for the relative influence of these factors on both the local and broad-scale distribution of large brown algae.

### 5.3 EFFECTS OF WATER MOTION

General Hypothesis: Severe water motion (~ 1 m/sec) limits the extent of canopy and the distribution of Macrocystis.

This hypothesis is not easily testable and has not been experimentally examined. As discussed in Section 2.6, stands of Macrocystis do not occur north of central California where surge conditions are strong and winter storms are severe. Surface canopies in the more protected areas of southern California tend to fluctuate in 3- to 4-year cycles, with older plants being prone to removal by water motion. In central California, however, winter storms tend to remove most surface canopies, and there is a marked seasonal change in their extent. On a local scale, North (1971b) suggested that the shoreward depth limit of Macrocystis is determined by surge conditions.

Severe winter storms were associated with the recent El Nino conditions (1982-83) along the entire coast of California. These storms removed most of the canopy plants at Point Loma in southern California, with the greatest mortality of plants in the shallowest (12 m) water (Dayton and Tegner 1984b). In contrast, at Stillwater Cove in central California, virtually all Macrocystis plants were removed by these storms

(Schiel and Foster, unpublished data). In both cases, many Macrocystis and understory kelps eventually recruited.

Except for abrupt mortality of plants due to storms, the factors associated with large-scale phenomena such as El Ninos are generally impossible to separate, however. Water motion is seasonally severe while temperatures are higher and nutrients lower.

The observations of Ebeling et al. (MS.) on a reef near Santa Barbara indicate that severe storms can have opposing effects on kelp communities, depending on algal abundances and sea urchin behavior prior to and after the disturbance (see discussion in Section 3.5). As with many studies, a possible complicating factor is the lack of knowledge about the intensity of algal spore settlement. Sea urchin foraging behavior may not have changed after the first storm had there been a large settlement of spores and subsequent large recruitment of algae. Nevertheless, this observational study indicates that water motion, sea urchin behavior, and kelp recruitment are related.

### 5.4 OTHER ABIOTIC FACTORS

#### 5.4.1 Depth Distribution

General Hypothesis: The depth distribution of kelp plants is limited by the abiotic factors of light and nutrients.

Some of the main problems faced by subtidal workers are the differences between areas and depths in physical and biological factors, and also the differences in levels of these factors among areas. Intertidal studies provide the best examples of patchiness in the occurrence of organisms within and between areas, and experiments to determine how this patchiness originates and is maintained. A particularly thorough quantitative survey of intertidal areas in eastern Australia showed that there were broadly overlapping vertical distributions of species, which were partially determined by exposure and substratum heterogeneity (Underwood et al. 1983). Species from different levels on the shore



have different physiological tolerances to regimes of light, temperature and exposure (e.g., Quadir et al. 1979). Even so, individual algal species may not occupy the zone where they grow best (e.g., Foster 1982b). Detailed experimental studies examining these types of interactions have rarely been done in subtidal algal forests.

Within sites, it has been observed worldwide that subtidal algal assemblages fall into broad depth zones (Kain 1963, Neushul 1965, Mann 1972a, Choat and Schiel 1982), and this is generally the case for *Macrocystis* communities (see Chapter 3). Most of the physical and biotic factors discussed in Chapters 2 and 3 will change gradually along a depth gradient within any one site. For example, the density of kelp stands usually decreases at depths beyond ~ 20 m, leaving isolated plants at greater depths (DeVinny and Kirkwood 1974; see Chapter 1). The pattern of distribution of physical factors can also be quite variable. While light attenuation occurs with depth, it may also be affected by water clarity and the presence of algal canopies (see Section 2.4). As a consequence of changing variables and the physiological tolerances of algae, the demography of species and composition of algal stands also change with depth.

The effects of depth-associated factors on algal production have been approached in several ways. North (1971c) measured the growth rates of three young *Macrocystis* fronds on each of four plants over a period of 39 days at depths of 8 m and 24 m on the edge of the Carmel submarine canyon. He found little difference among elongation rates of fronds, and concluded that the influence of depth on growth rates of young fronds is probably slight. Sample sizes were small in this study, and only young fronds on older plants were measured. Gerard (1976) found that within one site in central California, the variation in growth rates was extremely high from frond to frond, even for fronds which were initially of equal size and which were measured over the same time interval.

Dean et al. (1983) at the Marine Review Committee kelp ecology project in southern California have done the most

innovative and thorough research to date examining factors that affect the production of *Macrocystis* sporophytes from gametophytes. Their experiments will be discussed in detail in the next section. Of relevance to the depth distribution and abundance of *Macrocystis*, however, were their experiments that assessed the production of sporophytes at different depths. They attached ropes containing cultured gametophytes at different depths along a suspended cable (Figure 28). The

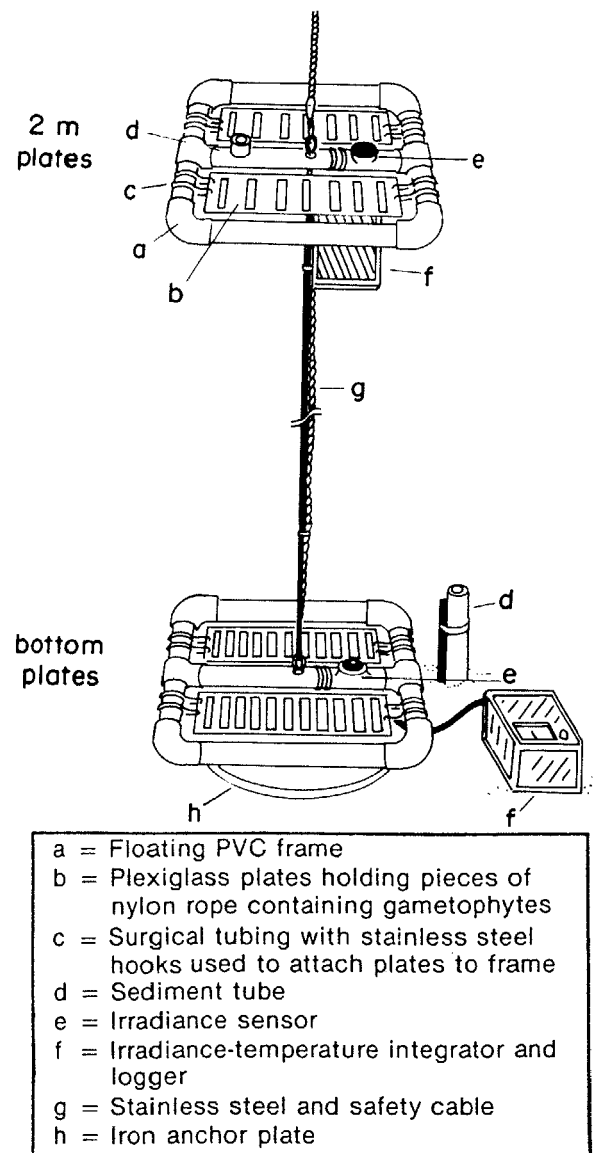

Figure 28. Field station used for *Macrocystis pyrifera* gametophyte outplants (Dean et al. 1983).

lowest ropes were on the bottom, with replicates at 2, 4, and 6 m above the bottom. They recorded the density of sporophytes produced from these cultures, and measured temperature and irradiance daily and total nitrogen weekly. Nitrogen levels were generally higher on the bottom, and lowest at 6 m off the bottom. Temperatures during August - October were lowest on the bottom and highest at 6 m, but differences were slight between depths during October - January. Irradiance was invariably lowest on the bottom, and progressively higher at the shallower depths. Temperature alone accounted for a relatively high proportion of the variance in sporophyte density at all depths (48%). Irradiance explained a significant portion of the variance in sporophyte density for all treatments combined, but was more important for bottom substrata. This was because light regimes on the bottom were, at times, below critical irradiance levels. Sedimentation levels also had a significant effect, being more pronounced on the bottom treatments.

A surprising result of these experiments was that there were not significant correlations between nitrogen levels and the production of sporophytes. Several outplants of gametophytes produced high densities of sporophytes despite low levels of nitrogen (0.2 - 1.0  $\mu\text{g-at/l}$ ). This lack of correlation was attributed to the fact that the outplants were within a narrow range of critical levels at all times, and that weekly measurements of total nitrogen may be too coarse a measurement to detect effects on settled substrata.

These experiments indicate that even relatively small differences in depth may have important effects on gametophyte growth, fertility, and the production of sporophytes. Critical thresholds in temperature and irradiance may be approached, while levels of sedimentation may be correlated with particular depths. These sorts of experiments which assess the performance of small plants while monitoring the physical environment are critical to an understanding of broad zonal patterns. The fact that larger sporophytes grow, and apparently do well in deeper areas at some sites, reveals little about how plants come to be in

those larger size categories. Gametophytes and young sporophytes must cope with the physical regimes of the micro-sites in which they settle, in much the same way as do terrestrial plants (e.g., Harper 1977). The logistics of altering and controlling physical regimes at this scale have not been worked out for field studies, but the experimental/correlative approach used by Dean et al. (1983) holds much promise.

#### 5.4.2 Variability Within Depths

General Hypothesis: The variability in levels of temperature, light and nutrients at the same depth within a locality results in the patchy distribution and variable abundance of algae.

There are no field studies that conclusively show the effects of temperature, light, and nutrients on any life-history stage of Macrocystis. Experimental studies have not been feasible because of the difficulty in controlling the levels of these correlated factors in the field. For example, Luning (1980) found that the total amount of light needed for gametogenesis in Laminaria increased exponentially as temperature increased. Dean et al. (1983) were able to quantify this in field experiments. Macrocystis spores were settled onto small ropes in the laboratory, and grown to the gametophyte stage before outplanting to the field. The densities of the sporophytes that eventually appeared were determined, while temperature and irradiance were measured with in situ sensors and integrating recorders. They found that there were threshold levels of light and temperature for the production of different densities of sporophytes (Figure 29). For example, no sporophytes were produced above a temperature of 17.6 °C or below irradiance levels of 0.3 E/m<sup>2</sup>/day. To get dense recruitment (> 50 sporophytes/cm<sup>2</sup>), temperatures were below 16.3 °C, and irradiance above 0.4 E/m<sup>2</sup>/day. Higher irradiance levels (1 E/m<sup>2</sup>/day) were required for production of higher densities of sporophytes as temperatures approached 16 °C. However, recent laboratory experiments indicate there is little interaction between light and temperature if nutrients are adequate.

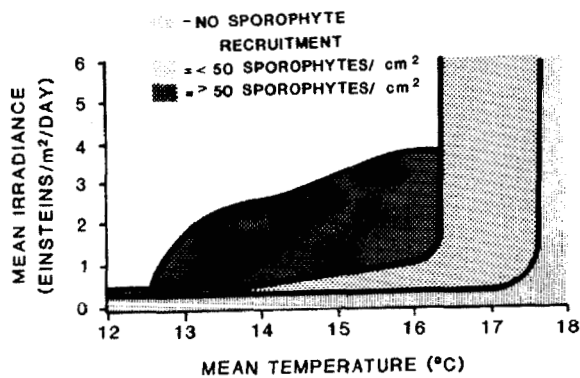

Figure 29. Irradiance-temperature response surface for *Macrocyctis pyrifera* sporophyte recruitment. Sporophytes counted on sections of rope initially inoculated with spores in the laboratory. When spores developed into gametophytes, the ropes were put in the field on the apparatus shown in Figure 28.

Since temperature and nutrients are inversely correlated (Section 2.5), these laboratory results suggest that it is the light-nutrient interaction that is important in the field (Deysher and Dean pers. comm.).

Different sediment loads could lessen the production of sporophytes by reducing irradiance levels below the compensation irradiance point (Table 1). Gametophytes were not killed by sediment, but failed to grow. In another study, DeViny and Volse (1978) found that sediment cover of 107 mg/cm<sup>2</sup> (0.45 mm thick) could reduce gametophyte survival by 90%. These results are similar to those of Norton (1978), who found that a covering of sediment reduced light levels below the growth compensation point for the kelp *Sacchariza polyschides*. Sediment also affects scour, nutrients, and micrograzer activity as well as light.

The availability of nutrients, particularly nitrogen, can affect the growth of macro-algae (see Section 2.5). Some species of large algae can maintain growth during periods of low ambient nutrients by building internal nitrogen reserves. In the case of *Macrocyctis pyrifera*, sporophyte tissue may have a nitrogen level 10,000 times that of the external supply (Gerard 1982b). Wheeler

and North (1981) found that NO<sub>3</sub><sup>-</sup> varied seasonally in inshore waters, and that growth rates of fronds were also seasonal. However, there was no clear correlation between growth rates and ambient NO<sub>3</sub><sup>-</sup>. Gerard (1982b) tested the effect of nitrogen depletion on growth rates of fronds *in situ* by moving a plant from an inshore kelp forest to an offshore area with a lower nitrogen environment. The transplant was moored at a similar depth to the offshore site (~7 m). She found that fronds maintained growth for two weeks, presumably as a result of internal nitrogen reserves, but that growth rate decreased in the third week. Despite the relatively small nitrogen-storage capacity of *Macrocyctis*, she concluded that nitrogen saturation is uncommon in southern California kelp forests.

Dean et al. (1983) did two types of experiments to test for the effects of nitrogen levels on sporophyte production. In the gametophyte outplant experiments described earlier, nitrogen levels in the water column were measured. There was no correlation between the production of sporophytes and nitrogen levels, suggesting that nutrients play a relatively minor role in recruitment when other factors such as light, temperature, and sedimentation are considered. However, temperature and nutrients are highly correlated, and the work of Zimmerman and Kremer (1984) indicates that nutrients must be measured at shorter time intervals than in these experiments. Dean et al. (1983) also did nitrogen addition experiments to assess the effects on sporophyte production. Racks of gametophytes were situated above trays of fertilizer, rendering the nitrogen concentration in the vicinity of the outplants greater than ambient. In these experiments, fertilizing the substrata did increase sporophyte recruitment. They also found that the plates on the bottom showed a greater increase in nitrogen than those higher in the water column, probably because of higher current velocities near the surface which diffused the fertilizer. This can also be the case for ambient nitrogen, with vertical stratification and high NO<sub>3</sub><sup>-</sup> concentrations only near the bottom (Gerard 1982a). In this case, the interaction between nutrients and water currents was important.

Gerard (1982c) also found evidence that at high concentrations of  $\text{NO}_3^-$  (25  $\mu\text{M}$ ), nutrient uptake was saturated at relatively low current velocities (2.5 cm/sec). Furthermore, she found that water surge and movement of plant surfaces in the water column were sufficient to saturate uptake, even in a dense Macrocystis forest with calm sea conditions and low current velocity.

Nutrients may, therefore, have different effects on the various life stages of plants, and this may also be related to season, stratification of nitrogen, and water motion.

The effects of light, temperature, nutrients, and their interactions have only just begun to be studied. Better field studies must be devised which can measure variability at different scales. For example, nutrients may have effects on a small scale within a kelp forest; there may also be very broad-scale effects over portions of the forests, or the entire kelp stand. Fronds on a single plant show variability in growth rates and nutrient uptake, but there is also variability among plants of the same age, exposed to similar environmental conditions. Experiments must be able to quantify these various levels of variability. Also, there is a need for careful controls with which to compare translocated or experimental kelp plants.

One type of experiment needed is a laboratory study examining different levels of light, temperature, and nutrients (see Table 11). Such a design will allow some measure of main effects and the importance of interactions. This experiment is currently being done by Deysher and Dean (pers. comm.).

These are central issues in the controversy of what produces "good years" and "bad years" for Macrocystis. Why is recruitment greater at some times and why are canopies more lush in different years?

## 5.5 EFFECTS OF COMPETITION

### 5.5.1 Canopy Removals

General Hypotheses: (1) Competitive interactions among species affect the local-scale distribution and abundances of individual species. (2) Bare primary substratum significantly increases the recruitment of large brown algae.

The most common method used to determine the effects of one algal species on another is the selective removal of algal canopies and the subsequent recording of which species either persisted in or recruited to the areas. Dayton (1975) removed canopies of several species at different depths at a site in Alaska. Five hypotheses were tested, each

Table 11. Outline of an example of a factorial laboratory experiment to assess the importance of light, temperature and nutrients, and their interactions, on gametophyte growth, fertility and the production of sporophytes. The design uses three levels for each factor: nutrients, light, and temperature. Number of replicates determined from initial trials and desired statistical power.

Nutrient	Nutrients 1									Nutrients 2									Nutrients 3														
	Light 1			Light 2			Light 3			Light 1			Light 2			Light 3			Light 1			Light 2			Light 3								
Temperature	T1	T2	T3	T1	T2	T3	T1	T2	T3	T1	T2	T3	T1	T2	T3	T1	T2	T3	T1	T2	T3	T1	T2	T3	T1	T2	T3	T1	T2	T3	T1	T2	T3
Replicates	1.																																
	2. (for each T)																																
	3.																																
	-																																
	-																																

relating to the effects of one laminarian species (or groups of them) on another. His experiments indicated that the species forming a surface canopy, Alaria fistulosa, was not a competitive dominant because other laminarian species did not invade clearances when this canopy was removed. Canopies of Laminaria spp., however, appeared to preclude the recruitment of Alaria. The rhizoidal growth pattern of L. longipes ensured that relatively rapid vegetative growth would allow this species to reform a canopy quickly, and so exclude other species from invasion. Two other canopy removals indicated that Agarum cribosum had little effect on other species, but that its cover increased when Laminaria spp. were removed.

These experiments clearly show that canopies of individual species affect other species. The nature of these effects, however, is not clear. Presumably, canopy effects were the result of light inhibition to understory species (see Section 2.4). Canopies may also impede the arrival of propagules to the substratum. One of the main problems, however, was the lack of information about reproduction for individual species. The apparent failure of some species to recruit successfully and the success of other species could be a reflection of the seasonal occurrence of propagules, which may not have been available for some species at the time of the clearances. In addition, percentage cover of canopies was used as a measure of abundance, and it was not clear whether plants that remained after clearances of one species increased in size, or whether significant recruitment occurred.

Many intertidal studies have shown that free space is a major requirement for successful recruitment of sessile species (e.g., Dayton 1971, Connell 1975). This is probably the case for subtidal regions as well, although there is little experimental evidence for this in Macrocystis forests. Sessile organisms, particularly algae such as articulated corallines, fleshy red algae and stipitate laminarians, may impede spore fall from larger plants, may already occupy available substrata, may have toxic

effects on settling spores, and may reduce light levels below threshold values for spore development.

Field experiments by Reed and Foster (1984) have shown that a combination of these effects can be important to kelp recruitment in central California. They experimentally removed canopies of over- and understory plants: Macrocystis, Pterygophora, articulated corallines, and encrusting corallines. The most abundant understory kelp in the forest, Pterygophora, reduced light levels to the substratum by up to 90%. Removal of this species resulted in a higher recruitment of kelp relative to control areas. Clearance of articulated and encrusting corallines, leaving patches of bare substratum, did not yield more recruits. Lower recruitment occurred in areas where the branches of articulated corallines were present, suggesting that the branches themselves impede spore fall and subsequent development, or that they may severely reduce irradiance to the substratum. Reed and Foster (1984) concluded that the major factor affecting recruitment was the reduction of irradiance caused by the Pterygophora canopy.

This is the most thorough set of experiments yet published involving manipulations of algal abundances in Macrocystis forests. Most combinations of factors (i.e., the presence and absence of each canopy) were used. A balanced experimental design, however, would have allowed statistical tests of all factors and their interactions, thus providing stronger evidence for their conclusions.

Pearse and Hines (1979) cleared a Macrocystis canopy from a 20 x 10 m plot and left one area uncleared as a control in a kelp forest off Santa Cruz, California. After 3 months, significantly more laminarians, of several species, recruited into the cleared plot. This difference was attributed to light inhibition caused by the intact Macrocystis canopy. Light measurements indicated that only about 0.2% of surface light reached the bottom under the canopy, while 3.8% reached the bottom in the cleared plot. The long-term effects of this differential recruitment were not recorded.

Again, this study suggests the importance of light to successful algal recruitment, but suffers from having only one experimental plot and one control, and the lack of separating other factors such as the effects of understory species.

A different result occurred in a kelp forest in southern Chile. Santelices and Ojeda (1984a) cleared a Macrocystis canopy from a 5 x 50 m transect. The dominant understory plant, Lessonia flavicans, increased in biomass in the non-removal area but most other permanent members of the community did not change in distribution. The method of removing the canopy, however, was different than in other studies. Plants were cut 1 m below the sea surface, rather than immediately above the holdfast. The senescence of cut fronds could have had an adverse effect on Lessonia in the removal area. Recruitment was not specifically recorded in this study, but there appeared to be a qualitatively different response to canopy removal in this southern kelp forest depauperate in laminarian species.

Kastendiek (1982) examined some interactions among three algal species in a shallow portion of a Macrocystis-dominated community at Santa Catalina Island in southern California. He found that two species were narrowly zoned with depth: Halidrys dioeca (Fucales) occurred abundantly at 0.5 m and 1.9 m below MLLW, with Eisenia arborea (Laminariales) occupying three intermediate depths (0.8, 1.2 and 1.5 m). The third species, the red alga Pterocladia capillacea, was most abundant beneath Eisenia canopies. By selectively removing each species, Kastendiek (1982) found that if Eisenia was removed, Halidrys could invade intermediate depths by growing adventitiously and preempting space. If both Halidrys and Eisenia were removed, Pterocladia was able to occupy free space. Thus, Eisenia appeared to be the competitive dominant at intermediate depths because its dense canopy excluded Halidrys. This, in turn, allowed Pterocladia to occupy the space beneath. Two other factors were cited as important to the coexistence of these species. Large storms had a differential effect on the species, removing most Eisenia plants in some areas while leaving Halidrys

intact. Differential recruitment was also important. Eisenia was able to recruit beneath Halidrys, yet even when free space was available at all depths, Eisenia had few recruits above and below the zone (1.2 m) where adult plants were most abundant. The relative recruitment failure in the lower area was probably not due to physiological restrictions because Eisenia adults are very abundant at depths to 25 m. In this case, the limited dispersal of algal spores or the differential survival of spores could be important factors.

### 5.5.2 Density of Macrocystis Stands

Hypothesis: Recruitment and growth at high densities has an adverse effect on the growth, reproduction, and survival of Macrocystis plants.

Evidence from many terrestrial studies suggests that individual plants in dense stands should exhibit lower growth, reproduction, and survivorship relative to plants in similar environments at lower density (Harper 1977). The fact that large, essentially monospecific aggregations of large brown algae commonly occur worldwide suggests that there might be advantages to plants in denser stands, in some situations. There is evidence both for and against adverse effects to plants in high density algal populations. Schiel and Choat (1980) found that two subtidal species in New Zealand, Ecklonia radiata and Sargassum sinclairii, had the largest plants in dense, single-species stands on one semi-exposed reef. These plants were of the same age and in an apparently similar habitat, although differences among local sites (boulders) may have been important. Cousens and Hutchings (1983) reached different conclusions for stands of brown algae in Nova Scotia. They found that large plants could occur at low density, and concluded that water motion was the most important factor determining size and morphology. Their evidence is equivocal, however, because ages of plants were not known, and plants were in different habitats on the shore. Black (1974) found that survivorship was density-dependent for recruits of Egregia laevigata (= menziesii), but that this was not the case after plants were three months old.

There is some information on density effects for Macrocystis. North (1971c) used three stands of different densities to examine growth rates of fronds. He found that the stand at highest density had plants which grew slightly faster than those at other densities, but attributed this result to unknown "localized factors."

Neushul and Harger (in press) planted adult Macrocystis (mean size of 25 fronds per plant) at different densities on a test farm near Santa Barbara, California. The densities used were 1 plant/m<sup>2</sup>, 1 plant/4 m<sup>2</sup> and 1 plant/16 m<sup>2</sup>. The results indicated that plants at the lowest density had the most fronds and greatest weight after a year, while the highest density plants fared the poorest. Their results suggest that shading in the denser parts of the stand caused the poorer growth. Possible complicating factors in this experiment were: (1) the initial use of adult plants, which may already have adapted to a particular growth regime; (2) the logistic constraint of using only one small experimental plot (0.24 hectares) with the different densities being contiguous; and (3) the placement of low and medium density plants toward the outside of the stand where peripheral light may have affected growth. Their experiment, however, forms a useful basis for selecting planting densities for the purpose of mariculture (see Chapter 6).

Mortality may also be affected by the density of stands. Work in both central and southern California has indicated that the major source of mortality for large Macrocystis plants is entanglement with drifting plants (Rosenthal et al. 1974, Gerard 1976). Large bundles of drifting plants may accumulate and remove more plants from the kelp forest during periods of increased water motion.

Intraspecific competition for light, nutrients, and space may prove to be important in large brown algal systems. Testing for these effects requires experiments which control for the ages of plants, habitats, depths, and localized factors associated with sites. These experiments can take the form of thinning experiments, whereby areas with high recruitment have treatments thinned to

lower densities. High recruitment into an area indicates that it is suitable, at least for the initial life stages of the alga. If different density treatments are contained in the area of initially high recruitments, site effects will be reduced. Another way to approach this problem is to outplant sporophytes at differing densities, and record subsequent growth and survival.

It has been suggested for some species in the Fucales that higher densities of adult plants result in release en masse of gametes, which may be important for good recruitment (Fletcher and Fletcher 1975, Schiel 1981). Greater densities may also be important to effect successful fertilization of gametophytes (that is, for males to find females). There is little information on these early life stages and density for Macrocystis.

Macrocystis forests may be extensive in size, with relatively high densities of plants and virtually 100% cover of the sea surface by algal fronds. Little is known about the importance of "patch size" to the growth, eventual sizes of plants, and reproduction. Macrocystis in small patches, such as artificial reefs, tend to suffer rapid deterioration and mortality due to fish grazing (LOSL 1983). The effects and importance of patch size can be tested, and are relevant to attempts at establishing algal populations where they do not presently occur.

### 5.5.3 Spore Dispersal

General Hypothesis: The distribution of algal spores or their differential mortality account for the distribution of adult plants.

The problem of determining whether spores have actually arrived to an area is important to arguments about competition among species (Denley and Dayton in press). There is increasing evidence that spore or germling dispersal is limited for many brown algal species, with most recruits appearing within a few meters of reproductive adult plants (Anderson and North 1966; Dayton 1973; Paine 1979; Schiel 1981, in press b; Deysher and Norton 1982). The problem of whether algal germlings can survive and grow in

zones different from where adult plants normally occur has been addressed in a few studies.

In a study in New Zealand, Schiel (1981) settled Sargassum sinclairii germlings onto plates, and placed them on a shallow reef (5 m) where adult plants were abundant and on a deep reef (15 m) where adult plants were scarce. Initial survival of germlings was better in the deep area. Once the young plants began to form blades, however, shallow plants grew at a much faster rate, while most deep plants grew slowly and eventually died. Schiel (1981) speculated that the major reason for few adult Sargassum plants in deep areas was that germlings rarely reached these habitats in great abundance, and that the few which did settle had a low probability of growth and survival. As in the studies of Schonbeck and Norton (1978, 1980) and Kennelly (1983), small crustacea were probably important sources of mortality for germlings which grew slowly.

Adult distribution may also be a reflection of spore distribution. This is a persistent problem in algal research, and one which is only just beginning to be addressed (e.g., Kennelly 1983). Spore fall is probably not evenly distributed in natural situations, and may be affected by current and surge conditions in much the same way as "seed shadows" occur in some terrestrial situations (Harper 1977). Dense aggregations of spores or germlings may also be important to the production of large algal stands (Fletcher and Fletcher 1975, Fletcher 1980). Denley and Dayton (in press) suggest ways in which spore fall may be examined using settlement plates and microscopic examinations, and techniques are now available for in situ microscopic examination of substrata (Kennelly and Underwood 1984). In such an experiment, Chapman (1984) found that the greatest proportional mortality for Laminaria longicruris and L. digitata occurred between the time the microscopic plants attached to the substratum and when they became visible, a period of about 6 weeks (see Section 4.3.3.1 for a description of his experiments). This is a unique study in that it assesses the number of spores produced for adult plants per square meter, the recruitment of

microscopic sporophytes that results from these spores, the visible recruitment of macroscopic sporophytes to natural substrata in the field, and the subsequent survivorship of the plants. This kind of innovative study is essential to clarify the distribution histories of species, and to assess whether competition among algal species is an important structuring force in algal communities.

## 5.6 EFFECTS OF GRAZING

General Hypothesis: The activities of grazers affect the distribution and abundance of large brown algae.

Many studies mention that the activities of grazers affect the distribution and abundance of large brown algae in subtidal regions, but there have been relatively few experimental studies which assess the nature of their effects. Most of our present knowledge about the effects of grazers on algal assemblages comes from experimental studies in intertidal areas, where herbivorous gastropods are usually the most abundant and important grazers (Underwood 1979, for review). Much of the small-scale patchiness in the abundances of intertidal algae is caused by grazing on filamentous and foliose plants, as well as on algal spores (e.g., Dayton 1971; Underwood and Jernakoff 1981, 1984). Algal cover and diversity may be dependent on the density of grazers in a given area (Lubchenco 1978, Underwood et al. 1983).

The regime of grazing generally changes abruptly in the boundary between intertidal and subtidal regions. Even on shores where the abundances of herbivorous gastropods such as limpets and trochids are great, their distribution tends to end where the zone of dense algae (normally furoids) begins in the immediate subtidal. Herbivorous gastropods tend to be less abundant in the subtidal, where sea urchins are normally the major grazing invertebrate. Herbivorous fish may also affect subtidal algal assemblages (Choat 1982, Gaines and Lubchenco 1982).



### 5.6.1 Invertebrate Grazers (Other Than Sea Urchins)

There are few published experimental studies that have assessed the effects of gastropods on algae in subtidal regions. A recent study by Watanabe (1983, 1984a) in central California assessed some of the effects of three species of Tegula in a shallow Macrocystis forest. These gastropods normally live and feed on the fronds and laminae of Macrocystis. During and after storms they are abundant on substrata below the plants, but quickly occupy fronds again when calmer conditions ensue. Their grazing activities, however, had no discernible effect on algal distribution or abundance.

Schiel and Foster (unpublished data) noted an increase in abundance of Tegula on the substratum of reefs in central California after winter storms removed the fronds of most Macrocystis plants. Tegula grazed heavily on the broken ends of old fronds and also on younger fronds, preventing them from growing. Tegula also grazed the ends of blades on Pterygophora which were damaged in the same storms. These effects were not long-lasting, however, as the vegetative blades and sporophylls re-grew in the spring.

Schiel (1981) used both exclusion and inclusion cages to assess the effects of limpets and turbinid and trochid gastropods in the shallow subtidal of northern New Zealand. Limpets and turbinids could prevent the establishment of large brown algae on a small scale (25 x 25 cm patches), presumably by grazing algal spores. These grazers had greater effects at higher densities.

Other invertebrate grazers such as abalone (Haliotis spp.) and sea stars (Patiria spp.) may have small-scale effects on algal abundances in Macrocystis forests, but their effects have not been assessed. Small crustacea can be very abundant in algal turfs (cf. Kennelly 1983) and may be major grazers on algal spores. Experiments assessing their effects, and the interactions of grazers that co-occur on areas of substratum, have yet to be done. There also may be indirect effects of invertebrates on algal assemblages. For example, Santelices et

al. (1983) have shown that spores of many seaweeds can survive digestion by sea urchins, and suggest that this may affect the abundance of opportunistic plants in grazed areas and perhaps the dispersal of species that occur later in succession. Schroeter et al. (1983) found that the sea star Patiria was an abundant predator of Lytechinus anamesus in the San Onofre kelp forest, affecting the local distribution of the sea urchin. This echinoid can be an important grazer of juvenile laminarians in local patches (Dean et al. 1984), and an alteration in its dispersion patterns could allow successful recruitment of kelps. Tegner and Dayton (1981) suggested that the spiny lobster, Panulirus interruptus, may be a major predator of sea urchins in southern California. This again could have effects on algal assemblages by reducing the incidence of grazing. Laboratory experiments indicated that lobsters would eat echinoids, but no data were presented on lobster abundances in the kelp forest, making it difficult to assess their present effects.

### 5.6.2 Effects of Fish

A few species of fish in Macrocystis forests are known to include algae in their diets (Quast 1968). A recent study by Harris et al. (1984) suggested that fish, particularly the halfmoon, Medialuna californiensis, and the opaleye, Girella nigricans, can be important grazers of small Macrocystis sporophytes on a local scale. At Naples Reef off Santa Barbara, fishes grazed about 59% of sporophytes (< 10 cm tall) that were concealed in a turf of ephemeral algae, while 94% of those on open reef quadrats were grazed. They reported that plants > 10 cm in height were not grazed, suggesting a size refuge from fish grazing. The result of this grazing was a small-scale change in the dispersion pattern of juvenile Macrocystis on the reef. They did not report the abundances of the fish present over the reef, however, and no observations of fish feeding behavior were mentioned.

There are no studies that demonstrate extensive modification of the biota by grazing fishes in Macrocystis forests. Indirect effects are reported in some

studies. Bernstein and Jung (1979) recorded that Oxyjulis californica may feed on the bryozoan, Membranipora, and mobile invertebrates that inhabit the laminae of Macrocystis. They suggested that the removal of these invertebrates by Oxyjulis may free the fronds from extensive encrustation and grazing.

Other anecdotal information (LOSL 1983) records that fish had a severe grazing effect on large Macrocystis plants that were moved to the Pendleton Artificial Reef, off San Onofre. Large numbers of halfmoon and opaleye were attracted to these reefs, and they quickly moved to the transplanted Macrocystis plants moored on the reefs. Predation of invertebrates and grazing of frond tissue by these fish caused the demise of Macrocystis within a few weeks.

Other indirect effects of fish on algal assemblages have been reported. Cowen (1983) found in the San Nicolas Island kelp forest that an alteration in the abundance of the sheephead wrasse, Semicossyphus pulcher, could affect local populations of the sea urchin, S. franciscanus. When sheephead were removed from a site, there was a slight increase in the number of sea urchins. He also recorded that in areas where sheephead densities were low, echinoids were highly exposed, whereas in areas with high densities of the wrasse, echinoids tended to be concealed in crevices. Nelson and Vance (1979) and Tegner and Dayton (1981) also reported that the densities of sea urchins may be altered by Semicossyphus. In all of these studies, however, the effects of sea urchin removal on the algal assemblages are not clear.

It would be useful to do experiments that assess the effects of fishes on juvenile algae and of feeding on the substrata where algae can recruit. Exclusion of fishes by cages and shields have been successful in some circumstances. Of particular interest is the variability of grazing effects and the scales at which they occur. Are the effects quite localized in some areas of particular reefs, or are there broader scale effects? A necessary part of such studies is a record of the abundances of each species of fish in experimental

sites, and observations of their feeding behavior to determine how selective feeding is. Choat (1982) gives a thorough review of the effects of fish feeding on the biota of temperate shores.

### 5.6.3 Sea Urchins

If there is any generalization that has made its way to prominence in the literature dealing with kelp communities, it is the dominating effect of sea urchins on the distribution and abundance of large brown algae. The words "control" and "regulating" are frequently used when discussing the effects of echinoids on algae, and "overgrazing" is often mentioned, evocative of an untoward shift from a "natural" community dominated by large macroalgae (e.g., Estes et al. 1978, Kain 1979, Duggins 1980, Tegner and Dayton 1981). The general implication has been that the grazing activities of sea urchins have a comprehensive effect on the character of the biotic assemblages on rocky reefs. This argument has also been expanded to an evolutionary context, suggesting that the evolution of kelp life histories and competitive abilities may be the result of responses to echinoid grazing activities (Vadas 1977, Steinberg 1984, Estes and Steinberg MS.).

There is little argument that sea urchins of many species may have dramatic effects on kelp assemblages on most temperate shores in both hemispheres (Lawrence 1975). The relatively rapid denudation of algal stands by mobile aggregations of sea urchins have been the focus of many investigations (e.g., Leighton et al. 1966, North 1974, Lawrence 1975, Dean et al. 1984). It is also clear that kelp can be abundant and persist in close proximity to echinoids (Foster 1975b, Cowen et al. 1982, Dean et al. 1984, Dayton et al. 1984, Harrold and Reed in press). Largely lacking, however, are detailed distributional data which examine the various spatial and temporal scales of echinoid abundance. Within a site, for example, the abundance of sea urchins is not constant, and may change with depth (Mann 1972a, Estes et al. 1978, Kain 1979, Foster 1982a, Choat and Schiel 1982). There may also be differences in abundances between local sites, between areas along a shoreline, and latitudinal

differences along coastlines occupied by kelp. A better knowledge of these distributional scales would provide a context for assessing the general importance of grazing by echinoids.

Within sites where sea urchins are abundant, their effects have been generally documented in three categories: (1) wholesale removal of algae; (2) the alteration of species diversity via feeding preferences and selective removal of algal species; and (3) the provision of cleared primary substratum suitable for kelp recruitment. We will discuss these below.

It is commonly observed worldwide that dense aggregations of sea urchins may remove large tracts of algae, creating so-called "barren grounds" (see Lawrence 1975 for review). After the dense vanguard of sea urchins has passed, their densities may decline, but may remain high enough to prevent successful kelp recruitment for many years in particular depth strata (Chapman 1981, Andrew and Choat 1982, Breitburg 1984). Thus, large persistent patches without kelp may occur in areas where sea urchins are abundant. These areas devoid of large brown algae often support a high cover of encrusting organisms (Ayling 1981, Choat and Schiel 1982, Breitburg 1984). There is no conclusive evidence for generalizations about the more subtle effects of grazers in kelp forests, as most investigations have focused on "barren" areas. Cowen et al. (1982) suggested that, at low densities, sea urchins may indirectly increase bottom cover of red algae by removing overstory brown algae that shade the bottom. Results of intertidal studies suggest that the effects of grazing on algal cover and diversity are dependent upon grazer density (Lubchenco 1978). We can find no published account, however, of an experiment where sea urchin densities were artificially increased to various levels in a kelp forest, and their subsequent behavior, movement, and feeding activities recorded.

Dean et al. (1984) used a series of observations and experiments to assess the effects of two species of sea urchins on Macrocystis in the San Onofre kelp forest. Two different modes of feeding were seen

for S. franciscanus. Over 3 years, aggregations were either relatively small and stationary, or large and mobile, advancing at the rate of 2 m/month. Stationary aggregations fed mainly on drift kelp and had no significant effect on kelp recruitment and abundance. Mobile aggregations of red sea urchins, however, removed most macroalgae in their path. Small transplanted Macrocystis were consumed over a 2-day period in the mobile aggregation, but remained intact amongst stationary echinoids and in a control area with no sea urchins. The results of a similar experiment for Lytechinus anamesus were equivocal, with small Macrocystis being consumed in some trials and ignored in others. Of particular interest in this study, however, was the careful 3-year observations of kelp and echinoid abundances along several transects through the kelp forest. Stationary and mobile aggregations of echinoids occurred within 100 m of each other, and feeding fronts of sea urchins were seen only twice during the course of the study. These quite different modes of feeding activity were very local-scale events, and apparently were dictated by the unavailability of drift algae leading to a change in the foraging behavior of the sea urchins. Dean et al. (1984) also concluded that both types of aggregations appeared to be unrelated to predation pressure from lobsters and fishes, although density estimates for these predators were anecdotal.

Many studies have shown that a preference hierarchy can be established for sea urchins consuming algal species in laboratory experiments (Leighton 1961, Lawrence 1975, Vadas 1977). A major question is whether these preferences reflect the manner in which algae are removed *in situ* by the same sea urchin species. Vadas (1977), for example, found that Strongylocentrotus droebachiensis clearly preferred Nereocystis luetkeana to Agarum cribosum in laboratory experiments. Sea urchins grew faster, and had a greater reproductive output when fed Nereocystis for long periods. He postulated optimal feeding strategies for sea urchins in nature, and argued for the coevolution of algae and urchins based on selective removal, plant defenses and benefits to urchins. This study, however, indicated

that sea urchins in nature fed mainly on drift Nereocystis, plants which had already been removed by other causes. In addition, the densities of urchin aggregations were not mentioned as a factor important to plant removal. Other studies have shown that sea urchin densities can be important in nature. Breen and Mann (1976) found that there was a non-linear effect of sea urchin numbers on algal removal in Laminaria longicruris beds in Nova Scotia. Schiel (1982) also postulated a non-linear effect of sea urchin feeding for subtidal areas in northern New Zealand. In parallel laboratory and field experiments, he found that the removal of plant material increased exponentially with sea urchin numbers. He also found that there was no correlation between the feeding preference hierarchies found in the laboratory, and those found in experimental situations in the field. The order of removal of algal species by sea urchins from natural stands appeared to be related to holdfast morphology, and was not correlated with hierarchies established in field experiments. Because sea urchins clumped on some replicates, and their feeding effect was non-linear, Schiel (1982) postulated an "all-or-nothing" effect of sea urchins on kelp removal.

A contrasting result was found by Harrold and Reed (in press) at San Nicolas Island. Red sea urchins (Strongylocentrotus franciscanus) were abundant both in Macrocystis-dominated areas and in patches devoid of large brown algae. The movement of the echinoids and their effects on the epibenthic community were affected by the availability of drift Macrocystis. Red sea urchins moved greater distances and fed on benthic organisms in "barren" patches, while they remained relatively stationary and fed on drift kelp in Macrocystis patches. This result is similar to that found by Mattison et al. (1977) in central California. One of the major differences between the activities of echinoid grazers in the eastern Pacific and those elsewhere may therefore be related to the preponderance of large kelps, and hence ample drift material, compared to the smaller stipitate laminarians found in most other parts of the world.

Much time and money have been, and are being, spent on "the urchin problem" (North and Pearse 1970, North 1983a) in southern California. The "problem" appears to arise primarily from a management viewpoint that Macrocystis forests are desirable, are the unvarying natural state of coastal waters, and the perception that localized aggregations of kelp-destroying sea urchins are somehow man-induced (Bascom 1983). Although this may be the case near large sewage outfalls, it is equally likely that waste discharge caused a reduction in algal biomass, and the urchins are simply eating what is left (see Chapter 6). Moreover, recent observations suggest that urchin "barren" grounds may come and go in kelp forests as natural variations in a dynamic community (see Chapters 3 and 4). Nevertheless, the consequent assaults on the lowly and meddlesome sea urchins have taken epic proportions, from destruction of tests with quicklime to outright mechanical maceration (Chapter 6). There was also a major effort organized through SCUBA diving clubs to smash sea urchins with hammers (North 1972a). These projects have met with only limited success. In some cases, Macrocystis became locally established, while in others, fish grazing and probably limitations in algal spore dispersal prevented establishment (North 1972a, 1973).

Evidence from studies elsewhere indicates that when adult plants are nearby, the removal of sea urchins can result in a large recruitment of kelp (Jones and Kain 1967, Duggins 1980, Andrew and Choat 1982). An experimental study examining this for Macrocystis forests was done by Pearse and Hines (1979) near Santa Cruz, central California. Large numbers of Strongylocentrotus franciscanus died over a wide area along the edge of a large stand of Macrocystis as a result of disease (see Section 4.7). Dense recruitment of Macrocystis, Pterygophora californica, and Laminaria dentigera occurred during the following spring in the previously urchin-dominated area. The boundary of the kelp forest also was extended seaward by over 100 m due to the removal of echinoids and their legacy of cleared substratum.

As with previously discussed aspects of experimental work in algal forests, the interactions of physical and biological factors are important determinants of spatial and temporal heterogeneity within a depth stratum, yet studies have previously been constrained to looking at only main effects. Large physical disturbances such as severe winter storms can differentially affect kelp species with long-term consequences for community composition (Dayton and Tegner 1984b, Ebeling et al. MS., Schiel and Foster in prep.). There are many important factors which have not been tested, and which could be important in many of the studies mentioned in this chapter (see Figure 24). For example, the abundance of echinoids and grazing gastropods can be positively correlated (Ayling 1981, Simenstad et al. 1978) and may be synergistic in some of their grazing activities. Alteration of kelp canopies and the abundances of fleshy, encrusting or articulated red algae not only alters the available space and the irradiance levels, but also the local grazing regimes, particularly small echinoids and herbivorous micro-invertebrates. The size of kelp stands could also be important in determining community structure (c.f., Dayton and Tegner 1984a), although there is little experimental evidence for this. Suitably designed field experiments testing specific hypotheses offer a promising approach to addressing these problems and removing the answers from the equivocal realm of anecdote, conjecture, and correlation.

#### 5.7 INDIRECT EFFECTS: SEA OTTER FORAGING

General Hypothesis: Sea otters enhance kelp abundance by removing sea urchins, the major grazers.

As already discussed in Section 4.6.2.2, sea otters (Enhydra lutris) consume up to a fourth of their body weight in food per day, feeding on a wide range of invertebrate species. Attempts at experimentally assessing their effects on nearshore communities have been hampered by the obvious logistic constraints of dealing with a mobile predator and the use of "natural experiments," that is, comparing areas with and without sea otters. The

importance of sea otter-sea urchin-kelp relationships is based on three types of evidence: (1) When large numbers of sea urchins are present in an area, kelp abundance may be low (see references in previous section). (2) Sea otters preferentially feed on large sea urchins when urchins are available. In areas where otters are abundant, sea urchins tend to be scarce and small in size (Estes et al. 1978, Breen et al. 1982, Van Blaricom in press). (3) Historical evidence indicates that sea otters were once abundant along the west coast of North America and were important predators in kelp forests (Estes and Van Blaricom in press).

Estes et al. (1978) examined the distribution and abundances of kelp and sea urchins at different sites in the Bering Sea, some of which had populations of sea otters. Strongylocentrotus polyacanthus were particularly abundant only in the site without otters, where there was little macroalgae. Sea urchins were larger at this site when compared to the site where otters actively foraged. Estes et al. (1981) found that in recently repopulated areas of the Aleutian Islands, sea otter diets consisted mainly of sea urchins, whereas epibenthic fish were the most important prey to an established otter population. Duggins (1980) provided experimental information from Alaska showing that when dense aggregations of echinoids are removed, a lush algal flora may develop. At the sites examined in Alaska, the evidence is that otters may be a "keystone species" (c.f. Paine 1966, Estes et al. 1978) in shallow communities.

The evidence is not so clear for the population of sea otters in California. Van Blaricom (in press) reviewed the literature concerning the recent expansion of the range of sea otters along the central coast of California. Dense sea urchin populations were reduced along the Monterey Peninsula, leaving generally small, concealed individuals (McLean 1962, Lowry and Pearse 1973). Indeed, there are no examples of dense aggregations of sea urchins persisting where otters are present. Van Blaricom noted that Nereocystis, an annual plant, tends to persist in the presence of sea urchins while Macrocystis does not. From recent

canopy maps, he postulated a change from Nereocystis to Macrocystis after otters removed sea urchins. While this may be the case for some sites in central California, the evidence is equivocal for others. Sea urchins are quite patchy in their distribution and effects, and there is often not a straightforward relationship between their abundances and that of particular kelp species (see references in previous section). In addition, winter storms and turbulent sea conditions can affect kelp abundance; Nereocystis tends to replace Macrocystis in such cases (e.g., Cowen et al. 1982). To resolve these questions, a better understanding is needed of the effects of sea urchins in kelp forests without otters. Macrocystis communities can certainly exist in the presence of this grazer. Giant kelp communities are variable in space and time, however, and dense aggregations of sea urchins may be the exception rather than the rule.

The historical evidence for the effects of sea otters is also somewhat equivocal. Simenstad et al. (1978) examined evidence from Aleut middens in Alaska and concluded that alternate stable states existed in nearshore communities. They argued that the strata containing large quantities of sea urchin and limpet shells coincided with the absence of

otters, due to hunting by Aleuts. The presence of fish remains coincided with times when otters were present, and macroalgae predominated.

There is also evidence in the middens in Monterey (Gordon 1974) and on San Nicolas Island, off southern California, that prehistoric man hunted sea otters. Dayton and Tegner (1984a) pointed out the large numbers of abalone shells seen on the island, suggesting that aboriginal man had a significant impact on the nearshore community.

Estes and Van Blaricom (in press) reviewed the data on the fluctuations in many shellfish populations and the possible effects of sea otters. The advent of otters and the decline of many shell fisheries are often coincident with increased fishing pressure, pointing to competition between modern man and otters for particular resources. They concluded that the near extinction of the sea otter permitted the development of shell fisheries in the first place. While these questions are interesting and relevant, the interactions between otters, particular fisheries, and natural variability of populations are complex and have forced the issues more into the political province than an experimental one.

## CHAPTER 6

### HUMAN USE, MANAGEMENT, AND POLLUTION

*Yet, if in any country a forest was destroyed, I do not believe nearly so many species of animals would perish as would here from the destruction of the kelp. Darwin (1860).*

#### 6.1 INTRODUCTION: MANAGEMENT AND MANAGEMENT AGENCIES

Giant kelp forests are an important economic and recreational resource. North and Hubbs (1968) estimated the value of marine resources taken from kelp forests near La Jolla in 1955-56 at nearly a million dollars. In current dollars and including the related values of boats, diving equipment, tourism, etc., this dollar value is certainly much higher (see also estimates in North 1971b). Moreover, living near the ocean is desirable, and disposing of wastes in nearshore areas is both convenient and inexpensive relative to land disposal or recycling. Kelp forests are thus heavily used, some uses are in conflict with others, and management is required to prevent deterioration. This is particularly true in highly populated southern California.

The preceding chapters have reviewed the diversity and dynamics of the giant kelp forest community, and it should be clear that various biotic and abiotic factors may interact to structure the community at a particular site. It should also be clear that, for most of these factors and interactions, we know only what is plausible, and are far from making quantitative predictions about community dynamics and the effects of particular perturbations. In this context, management is presently an illusion. Predicting the effects of all but very extreme changes in the abiotic environment or in particular species is nearly

impossible. However, man continues to harvest organisms from, and discharge wastes into, kelp forests, adding to the dynamics of the system. Moreover, many of the groups involved in these activities are politically and/or economically powerful, making management decisions even more difficult and partly removed from the meager environmental data that are available.

Management is further complicated because, except for surface canopies, observations of community and population changes must be made while under water. Even occasional surveys in a few forests require trained divers and considerable equipment. In addition (and for the same reasons), background information against which to measure change is lacking, and there may be multiple factors causing change at a particular site (e.g., fishing, sediment from river discharge, waste discharge) or in a particular region (e.g., cumulative waste discharge in southern California, changing oceanographic conditions). Fay et al. (1972) review these multiple pollution problems in southern California.

Management of biotic resources has been largely by regulation based on catch statistics for particular species. The State of California Department of Fish and Game has primary responsibility for most biotic resources, and can regulate numbers of fishermen, catch size, and areas fished. The Department of Fish and Game also maintains a marine mammal research

program, and recommends management policy, but the Marine Mammal Protection Act of 1972 transferred primary responsibility for sea otters to the United States Fish and Wildlife Service, and responsibility for other mammals to the National Marine Fisheries Service.

The management of the abiotic environment of kelp forests improved considerably with the passage of the federal Clean Water Act. Prior management dealt almost solely with questions of direct effects on human health. Many agencies now scrutinize ocean discharge and construction activities that may alter nearshore waters, and most of these agencies require the maintenance of community "health" and "balance of indigenous populations." At the Federal level, these agencies include the Environmental Protection Agency, the U.S. Army Corps of Engineers and the U.S. Coast Guard. At the State level, the California State Water Resources Control Board and regional boards regulate discharge into the ocean under guidelines set forth in the California Ocean Plan. Additional control over coastal development that might affect kelp forests is provided by the California Coastal Commission and cities and counties through local coastal programs.

## 6.2 COMMERCIAL RESOURCE HARVESTING

### 6.2.1 Plants

6.2.1.1 Macrocystis. One of the oldest and economically most important uses of giant kelp forests is for kelp harvesting. Kelp has been harvested in California since 1910 by various companies. Nearly 400,000 wet tons per year were harvested during 1917 and 1918 (Oliphant 1979), primarily as a source of potash for making gunpowder during World War I (Hult 1917, Frey 1971). During this period, harvesting was often done by putting a cable around a stand of kelp, and dragging the plants from the bottom with little regard for the environment (McPeak and Glantz 1984).

The uses of kelp and the methods of harvest have changed considerably since the early 1900's. At present, Kelco Company in San Diego is the major harvester, with small amounts taken by other

groups for abalone food (see Animals below). The emphasis has shifted from potash to algin production. Algin is a hydrocolloid extracted from kelp that, after further chemical processing, has a variety of uses as an emulsifying and binding agent in food and pharmaceutical industries (Chapman 1970, Frey 1971). A number of regulations have been imposed by the State of California to ensure that harvesting activities have a minimal impact on kelp forests (see Bowden 1981 for a thorough discussion). Stands of kelp are given numbers by the State, and some are leased to harvesting companies while others remain open to anyone with a harvesting permit. These companies pay a royalty to the state for each wet ton of kelp harvested (Bowden 1981). Harvesting is now done by ships with large cutting devices on the stern (Figure 30). The ships back through the forest and, much like a hedge trimmer, cut the canopy no lower than 1.2 m below the surface in a strip 8 m wide. This allows vegetative

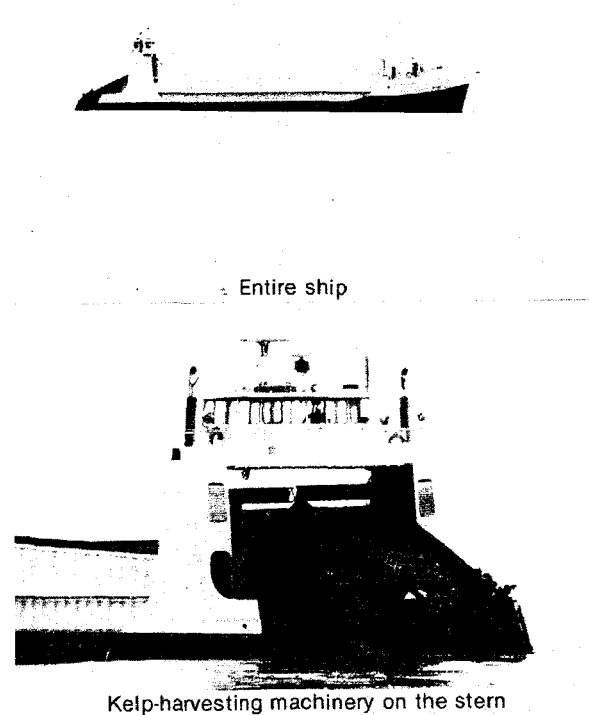

Figure 30. A modern kelp-harvesting ship operated by Kelco.



regrowth from unharvested subsurface fronds on cut plants. In areas where Nereocystis luetkeana and Macrocystis co-occur, the amount of N. luetkeana harvested is restricted by law. Nereocystis luetkeana is an annual, and its reproductive blades occur near the surface. Harvesting too much Nereocystis could inhibit its re-establishment.

Between 100,000 and 170,000 wet tons of Macrocystis are currently harvested annually in California (Frey 1971, Oliphant 1979), and sales by the kelp harvesting industry exceed \$35 million a year (Wilson and McPeak 1983). Forests are also harvested in Mexico with plants imported to Kelco Company in San Diego. The majority of the California harvest normally comes from the large forests in southern California (Barilotti pers. comm.), but harvesting occurs as far north as Carmel Bay in central California. Particular stands in southern California may be harvested up to three times per year (see McPeak and Glantz 1984 for a review of kelp harvesting and uses).

Kelp harvesting has a variety of possible impacts on giant kelp, kelp forests, and associated nearshore communities. Concern over these impacts has been a major stimulus for kelp forest studies since the late 1950's. The primary concerns have been the possible destruction of kelp stands, destruction of canopy-dwelling invertebrates and fishes during harvesting operations, reduction in fish populations due to loss of food and/or habitat, and an increase in beach erosion and amount of drift kelp on beaches. Early studies of these potential problems were summarized by North and Hubbs (1968), who concluded that "No adverse influence of harvesting could be found among the statistics or field observations for the periods studied." Uncut fronds grow to replace those cut, and it appears that only occasionally is an entire plant torn from the bottom during harvesting operations (Rosenthal et al. 1974). Harvesting the canopy increases light on the bottom, and may enhance recruitment of Macrocystis (Rosenthal et al. 1974, Kimura and Foster in press). Miller and Geibel (1973) found that adult Macrocystis abundance declined after repeated experimental canopy removal

at Point Cabrillo near Monterey. Kimura and Foster (in press) found no adverse effects after a single experimental harvest in Carmel Bay. The latter study more closely resembled commercial harvesting as currently practiced in Carmel Bay, and suggests that Miller and Geibel's (1973) results represent what may happen in central California if an area is over-harvested. Kimura and Foster (in press) did find that the timing of recruitment in kelps (Macrocystis and Pterygophora californica) changed in harvested areas, but this change had no apparent negative effects. Barilotti et al. (in press) found that survivorship of adults was not reduced in the two harvested forests they studied.

No overall reduction in fishes or invertebrates in particular forests has been reported due to harvesting operations, even though numerous organisms are removed along with the cut fronds (North and Hubbs 1968, Miller and Geibel 1973). Hunt (1977) did find significant declines in turban snail (Tegula montereyi) densities in harvested areas in Carmel Bay. Sea otters avoid kelp harvesting ships, and no mortality related to kelp harvesting operations has been reported for this or other mammals.

Clendenning (1971b) estimated that 10% or less of Macrocystis production is removed by harvesters in harvested forests. Possible changes in consumer populations in kelp forests or elsewhere (beach, offshore) that may be an indirect result of removing this primary production have not been investigated.

Recent research on growing Macrocystis for fuel is discussed in Section 6.6.2. Macrocystis has also recently been introduced in the People's Republic of China to possibly replace Laminaria as a source of food and algin (Foster pers. obs.).

6.2.1.2 Other plants. The only other plant commercially harvested from California kelp forests is Gelidium robustum, a source of high-quality agar (Figure 17). This plant is occasionally harvested by divers when prices are high (Frey 1971). The plant is very susceptible to overharvesting, as it grows

slowly and does not appear to recruit rapidly when completely removed from local areas (Barilotti and Silverthorne 1972). One company has recently leased a near-shore area for the purpose of cultivating G. robustum (Bowden 1981).

## 6.2.2 Animals

6.2.2.1 Fishes. North (1971b) lists 37 species of fish (including "rockfish" as one species) associated with kelp forests that occur in the commercial and party boat catch in California. Most of these species are also caught in areas without kelp forests, and catch statistics are not reported specifically for kelp communities. Thus, the catch and status of stocks in kelp forests are uncertain. North (1971b), using data from Davies (1968) estimated that about 90% of the "rockbass" (kelp bass plus sand bass) catch for southern California came from areas that included kelp forests, and that about 70% of the entire party boat fish catch came from areas with kelp.

Drift kelp is probably an important source of energy for communities other than kelp forests, so kelp forests may indirectly provide some of the energy base for fisheries in other habitats (see Chapters 3 and 4). Moreover, declines in kelp production could ultimately be reflected in declines in nearshore fish stocks, as has been suggested by studies in Alaska (Estes et al. 1978).

Miller and Geibel (1973) and Love (1980) indicated that some fishes may occur in local populations on particular reefs, with little movement between reefs. Thus, local areas may be subject to overfishing. Miller and Geibel (1973) recommended management by zonal opening and closing in central California.

Tegner (1980) suggested that sheephead have declined due to overfishing in some southern California kelp forests, and because these fishes eat sea urchins, the declines may be partly responsible for locally high urchin densities. Cowen's (1983) experimental sheephead removal supports this latter suggestion.

Frey (1971) discussed the status of other California fisheries, including

algae and invertebrates, and makes a number of management recommendations. The catch of many species associated with kelp forests is declining, and it is commonly observed that large individuals have become rare. This is particularly true of Stereolepis gigas, the giant sea bass, in southern California. This fish is occasionally found in giant kelp forests, and is listed as a megacarnivore by Quast (1971a). Large individuals (over 150 kg in weight and 2 m long) were once fairly common and must have been an impressive sight swimming through the kelp. Unfortunately, recent divers have been denied this experience as spear and hook-and-line fishermen preyed heavily on these huge (and perhaps over 90 years old; Frey 1971) fish, and we could find no recent observations of such fish in kelp forests.

6.2.2.2 Abalone. Abalone are the only commercially fished mollusc in California kelp forests. Animals are harvested by divers, and until recently, the main species taken were red abalone (Haliotis rufescens) and pink abalone (H. corrugata; see Section 4.4.3.2). In the peak year of 1957, slightly over five million pounds were landed (Cox 1962), which is roughly a million and a half animals (using an average conversion value of 1 doz. abalone = 40 lb.; see Cox 1962). Total landings have declined by ~ 80% since 1966 (Table 12), due to overfishing (Tegner 1980), habitat loss, illegal fishing, improper catch methods (Hardy et al. 1982), and removal by sea otters (Miller and Geibel 1973, Hardy et al. 1982). However, even though sea otter foraging was highly correlated with the decline in abalone stocks in the San Luis Obispo area (Miller and Geibel 1973, Hardy et al. 1982), this area contributed only about 20% of the total California catch in 1968 (calculated from data in Heimann and Carlisle 1970). Otter foraging in the San Luis Obispo area began around 1970 (Hardy et al. 1982). Thus, factors other than sea otter foraging have had a great impact on the statewide decline in the abalone fishery noted above (see also Estes and Van Blaricom in press). The less preferred, shallow-water black abalone (H. cracherodii) now makes up the majority of the catch (Table 12).

Table 12. Commercial landings of abalone, lobsters, and sea urchins in California, in pounds.

Species	1956 <sup>a</sup>	1966 <sup>b</sup>	1976 <sup>c</sup>	1982 <sup>d</sup>
Abalone				
Red	2,400,000 <sup>e</sup>	2,507,305 <sup>d</sup>	739,621	363,000
Pink	1,800,000 <sup>e</sup>	2,162,941 <sup>d</sup>	431,143	76,845
Black	0 <sup>d</sup>	0 <sup>d</sup>	356,751	382,847
Others	84,063	293,310	205,303	71,182
Total	4,284,063	4,963,556	1,732,818	1,093,874
Lobsters	735,869	489,088	292,534	477,426
Sea Urchins	0	0	11,106,426	17,228,795

<sup>a</sup>From Anonymous 1958.

<sup>b</sup>From Heimann et al. 1968.

<sup>c</sup>From Oliphant 1979.

<sup>d</sup>Ebert pers. comm.

<sup>e</sup>From Cox 1962.

The mainland coast in Los Angeles and Orange Counties has recently been closed to abalone fishing (Ebert pers. comm.), and restoration of stocks is being attempted by planting laboratory-grown juveniles in the field. These restoration attempts have not been very successful, but new techniques are being investigated (Ebert pers. comm.). Even if restoration resulted in commercially harvestable stocks under present environmental conditions, restoration efforts have a dim future if the sea otter population expands into southern California. Sea otters can reduce abalone distribution to cracks and crevices where individuals are barely accessible to man (Lowry and Pearse 1973).

6.2.2.3 Sea urchins. Significant commercial harvesting of red sea urchins (*Strongylocentrotus franciscanus*) began in 1970 (Tegner and Dayton 1977). Animals are harvested by divers, and the roe is extracted and shipped mainly to Japan, where it is considered a delicacy. The California sea urchin fishery has since expanded rapidly to become one of the largest fisheries in the State, with over 17 million pounds landed in 1982 (Table

12). Juvenile red sea urchins frequently occur under the spines of adults in southern California (Tegner and Dayton 1977). Thus, removal of adults not only reduces reproductive potential, but also affects juvenile habitat, so the potential for a high, sustained yield from the fishery may be poor (Tegner and Dayton 1977). Wilson and McPeak (1983) suggested that harvesting red sea urchins may result in increased abundances of purple and white sea urchins.

6.2.2.4 Lobster. The spiny lobster *Panulirus interruptus* is commercially fished with traps in southern California. Lobsters are often associated with giant kelp forests, and traps are frequently set along the outer and inner margins of the surface canopies. This fishery has also declined since the peak harvests of the 1950's (Tegner 1980; Table 12), and because this animal can eat sea urchins (Tegner and Dayton 1981, Tegner and Levin 1983), Tegner (1980) suggested that local lobster declines, like those of sheephead, may be partly responsible for increased sea urchin abundance. A similar scenario leading to extensive losses of kelp beds

in Nova Scotia was proposed by Mann and his co-workers (Mann 1973, Breen and Mann 1976; but see Pringle et al. [1980] for alternative views).

Kelp forests are also a source of organisms for commercial collectors who sell plants and animals for educational and research use. The number of organisms removed is probably insignificant relative to commercial and sport fisheries, and most are otherwise not harvested for food by anyone.

### 6.2.3 Habitat Use

Commercial and recreational boat traffic often goes through giant kelp forests, and gaps or channels through canopies, created by propellers cutting surface fronds, are common where traffic is heavy. Occasional small strips are cut by light boat traffic. Heavy traffic may cause a reduction in adult giant kelp density, and an increase in juvenile kelp and understory red algae (North 1957). Small strips probably fill in again by vegetative growth. Except where channels are produced, drivers of small boats generally avoid kelp canopies as the cut fronds easily foul propellers and water intakes of engines.

Various pipelines, particularly from offshore tanker facilities, are placed through kelp forests. The pipe and any covering structures, however, are usually soon covered with organisms including kelp, and probably have little long-term impacts. Short-term effects include damage to organisms in the path of the pipeline, and possible increased turbidity and sedimentation during construction.

A highly probable future use of giant kelp forest habitat is for mariculture facilities. Various research programs currently use kelp forests to test potential culture techniques, and one lease has been given to grow Gelidium robustum (see Plants above). Giant kelp forests are good potential sites for abalone culture. With declining natural stocks and heavy predation by man and sea otters (see Abalone above), a profitable technique may be to place juvenile abalone in structures that encourage algal drift accumulation

but discourage predation, and then place these structures within giant kelp forests.

## 6.3 RECREATIONAL USE

### 6.3.1 Sport Fishing

Kelp forests are favored areas for hook-and-line and spear fishing, and sport divers harvest lobsters, crabs, scallops, and abalone by hand. The extent of this fishing and possible effects on populations are largely unknown as use and catches are not reported. Miller and Geibel (1973) reported a 540% increase in sport diver activity from Pismo Beach (near San Luis Obispo) to the Oregon border between 1960 and 1972. There are thousands of divers and sport fishermen in California, and they are a common sight in kelp forests throughout the State when weather conditions are favorable. Numerous charter boats provide diver transport to offshore islands, especially Santa Catalina Island off Los Angeles. Divers occasionally take non-game species as curios. This is illegal, however, in California without a scientific collecting permit.

### 6.3.2 Other Recreational Activities

Numerous divers use giant kelp forests for underwater photography or simply enjoyment, without any fishing. Non-divers visit the coast to observe surface organisms from shore or in tour boats; sea otters are a special attraction in central California.

### 6.3.3 Governmentally Regulated Areas

Many levels of government have established a variety of special use areas along the California coast, and some of these areas have been established because of their proximity to giant kelp forests. In addition to city and county parks, the State has an extensive park system where fishing, collecting, and other uses of nearshore habitats are more highly regulated. State reserves such as the one at Point Lobos near Carmel also regulate public access, and in addition, further restrict fishing, collecting, and even observational sport diving. Miller and Geibel (1973) pointed out the value of

such areas as natural baselines for comparisons with areas more disturbed by man's activities. Reserves also serve as research areas where study sites and experiments are less likely to be disturbed by man.

The Federal Government has recently established the Channel Islands National Park and National Marine Sanctuary that include Anacapa, Santa Cruz, Santa Rosa, San Miguel, and Santa Barbara Islands off southern California. The waters (including kelp forests) in this area have no special fishing, collecting, or development status as a result of the park, but sanctuary designation gives special protection from possible pollution, including new oil drilling. Similar protection from waste discharge is provided in the 34 coastal sites designated by the State Water Resources Control Board as Areas of Special Biological Significance. Many of these include giant or bull kelp forests (e.g., Carmel Bay, portions of Santa Catalina Island, Saunder's Reef near Point Arena).

#### 6.4 SCIENTIFIC USE

Scientists use kelp forests for a variety of studies, including many that provide background information to aid in management decisions. Some areas, such as the Hopkins Marine Life Refuge at Point Cabrillo near Monterey have been established by the State as scientific research areas. Unfortunately, hook-and-line fishing is often not restricted in such areas, making fish and fish-related studies difficult. Scientists must have collecting permits issued by the State to remove organisms, and must obtain special permission from particular agencies (e.g., park authorities, California Fish and Game Commission, refuge managers) to work in parks, reserves, and refuges.

#### 6.5 POLLUTION -- MAN-CAUSED ENVIRONMENTAL CHANGE OTHER THAN FISHING

##### 6.5.1 Pollution From Commercial, Recreational, and Scientific Use

The uses of kelp forests discussed above generally do not produce significant waste discharge or direct disturbance of other organisms. The exception is the

introduction of the brown alga Sargassum muticum (see Chapters 3 and 4). This alga was accidentally introduced into Washington with oysters from Japan. It spread from Washington to southern California, and may displace giant kelp in some sites at Santa Catalina Island (Ambrose and Nelson 1982).

##### 6.5.2 Coastal and Inland Construction

Coastal construction usually does not directly impact offshore kelp forests, but it could have indirect effects via changes in water currents, turbidity, and sedimentation. These effects have not been documented as they are often impossible to separate from natural changes associated with varying oceanographic conditions, storm intensity, and terrestrial runoff. Dams impede the flow of sediment into the ocean. Their indirect effects have been shown on beaches, but potential effects on kelp forests have not been studied.

##### 6.5.3 Oil

The effects of large oil spills on kelp forest communities along the western Pacific coast have been studied twice: once during the 1957 Tampico tanker spill in Baja California, Mexico, and again during the 1969 Santa Barbara offshore well blow-out and spill. The Tampico spill occurred when a tanker carrying diesel fuel wrecked at the mouth of a small, shallow cove containing a small stand of Macrocystis pyrifera. The effects were studied by North et al. (1964). Massive mortality occurred among invertebrates (including sea urchins, abalone, lobsters, and sea stars). Damage to plants was less obvious, and by July 1957, 5 months after the spill, the vegetation in the cove was obviously increasing and juvenile Macrocystis were abundant. Algal species diversity and abundance quickly increased, with Macrocystis covering much of the cove by July 1958. North et al. (1964) attributed the increased algal growth to lack of grazing, as most grazing animals were killed by the oil. Most animals had recovered by 1961, but the abundances of sea urchins and abalone had not returned to pre-spill levels by 1963.

Crude oil from the Santa Barbara spill polluted a large portion of the mainland coast, and many of the Channel Islands (Foster et al. 1971a). Damage to kelp forest communities is discussed in Foster et al. (1971b), and overall damage to marine organisms is reviewed by Foster and Holmes (1977). Assessment of spill effects was complicated by record storms that occurred at the same time as the spill. Numerous birds associated with kelp were killed by the oil, but other than a decline in mysid shrimp abundance (Ebeling et al. 1971), little damage to kelp forest algae, invertebrates or fishes was observed, even though considerable quantities of oil fouled the surface canopies (Figure 31). The partially weathered crude oil appeared to stay on the surface of the water, and did not stick to the fronds of giant kelp.

Additional damage may have occurred if the more volatile components of the oil had not had time to evaporate before reaching shore, or if more toxic refined products were spilled, as during the Tampico wreck. If a spill like that in Santa Barbara occurred in central California, it would probably have a severe impact on sea otters (see Section 6.7 below and Siniff et al. 1982 for review).

Santa Barbara and other areas along the southern California coast have natural oil seeps in or near giant kelp forests. The oil from these seeps fouls beaches and produces surface slicks (Mertz 1959). Flow rates of seeps near Santa Barbara vary from 50 to 70 bbl/day (Allen et al. 1970), and oozing tar mounds are sometimes visible on the bottom within giant kelp forests (Spies and Davis 1979). The latter investigators compared soft bottom organisms around a subtidal seep with those around non-seep areas, and found a similar diversity, but increased abundances near the seep. They suggested that bacteria may degrade the oil and provide an enriched food source for the local infauna, and that some organisms adapt to oil exposure by producing enzymes that detoxify assimilated oil.

#### 6.5.4 Power Plant Discharge and Intake

The San Onofre Nuclear Generating Station (SONGS) near Oceanside north of



Figure 31. Aerial photography of giant kelp canopy during the Santa Barbara oil spill. A, oil streaming from kelp canopy; B, black area of heavy oil on beach. (Photo by Mark Hurd Aerial Surveys, Goleta, Ca.)

San Diego currently discharges heated water in the vicinity of a kelp forest. Based on a variety of surveys, the discharge from the first operating unit of this plant has had little or no effect on the San Onofre kelp forest 1 km away (McGrath et al. 1980). Two new and larger units recently began operation. These have elaborate discharge diffuser systems which should eliminate most thermal effects (Murdoch et al. 1980). However, by placing the intakes for these units in more turbid, shallow water, and by entraining large amounts of bottom water during discharge, these units are predicted to increase turbidity around the discharge (Murdoch et al. 1980). Because the discharge pipes for these units are within 200 m of the San Onofre kelp forest, the increased turbidity could have significant impacts on Macrocystis and

other plants. Other predicted effects of the discharge on the kelp forest include a reduction in nearshore fish stocks due to mortality of various life stages during intake and/or passage through SONGS, a reduction of mysid shrimp in and around the kelp forest (Murdoch et al. 1980), and an increase in fouling organisms on kelp blades (Murdoch et al. 1980, Dixon et al. 1981). The kelp forest has been extensively studied by the Marine Review Committee (Murdoch et al. 1980), and Southern California Edison Co. (reviewed in McGrath et al. 1980), and before-after discharge comparisons for the new units should provide comprehensive information on the effects of the power plant on the kelp forest community.

Another large nuclear power plant at Diablo Canyon near San Luis Obispo has not yet gone into full operation. This plant has an intertidal discharge that will release large volumes of heated water directly into a small cove with a stand of bull kelp (*Nereocystis luetkeana*). Elevated temperatures may eliminate bull kelp and other cold water species in the cove, and may affect populations in the vicinity of the cove. Comprehensive baseline studies have been done in the area by Pacific Gas and Electric Company and the California Department of Fish and Game, so changes after discharge begins (assuming the power plant starts operation) should be well documented. It remains to be determined how (or if) biological changes observed at these sites will affect the operation of the plants or the siting and operation of future plants.

Neither power plant is predicted to cause significant changes in kelp forest communities due to discharge of toxic compounds. Over 1,000 dead abalone were observed, however, in Diablo Cove after an early cold-water test of the Diablo Canyon Power Plant discharge system. Apparently, sea water was held in the cooling system for some time, and then released. The sea water contained high levels of copper from the condenser tubing, and when discharged, caused the abalone deaths (Martin et al. 1977). Damage to other organisms was not reported. The copper-nickel tubing has since been replaced by titanium (Martin et al. 1977).

#### 6.5.5 Sewage Discharge

Domestic wastes contain nutrients that may increase plankton productivity, and thus turbidity, and may also contain sludge particles that increase turbidity as well as sedimentation rates and sediment thickness on the bottom. Industrial wastes may cause similar effects, and also may contain toxic metals and organic compounds that can directly affect organisms. Discharged pathogens may harm man and other organisms. Thus, sewage discharge has the potential of significantly altering kelp communities and man's use of them (Table 1).

As discussed in Chapters 2 and 3, there is good indirect evidence that sewage from the Los Angeles area, discharged in the vicinity of Palos Verdes, contributed to the decline and eventual complete loss of one of the largest giant kelp forests in California. The decline of the Palos Verdes kelp forest began in the 1940's and 1950's as discharge rates increased. The community did not recover after the warm oceanographic period of the late 1950's (Grigg and Kiwala 1970, Wilson 1982). Increased turbidity (Eppley et al. 1972), sludge on the bottom (Grigg and Kiwala 1970), toxic substances in the discharge such as DDT (Burnett 1971), and possibly copper (that can inhibit giant kelp gametophyte growth and fertilization at low levels; Smith 1979), and other metals may have all contributed to the decline and lack of recovery. With recent improvements in discharge quality, giant kelp has begun to return to the area (Wilson 1982).

A similar but less drastic decline occurred in the Point Loma kelp forest, one end of which is near discharges from San Diego, and the other near the entrance to heavily developed Mission Bay. As for Palos Verdes, the decline at Point Loma began near the sewer discharge area (see figures in North 1976). Smaller, primarily domestic waste outfalls appear to have quite localized effects, and no general adverse impacts have been reported.

## 6.6 KELP FOREST RESTORATION AND THE CREATION OF NEW KELP FORESTS

### 6.6.1 Restoration

The declines in kelp forests around sewer outfalls and during the warm water years of the late 1950's (see above) stimulated numerous continuing attempts at restoration. The largest project was the Kelp Habitat Improvement Project under the direction of W. North. Kelco Company, the largest kelp harvesting company in the State of California, has also endeavored to increase Macrocystis abundance, particularly in the Point Loma forest near San Diego. Most recent kelp restoration activities have been by the California Department of Fish and Game (Wilson and McPeak 1983).

Kelp restoration has variously involved killing sea urchins, removing possible competitors such as understory kelps, transplanting adult or juvenile Macrocystis, and "seeding" areas with microscopic sporophytes grown in the laboratory (see North 1976b for a review). Some or all of these techniques have been tried at various times in various areas. Sea urchins have been killed by divers with hammers, by chemical treatment with quicklime (see Bernstein and Welsford 1982 for a description and discussion of this technique), and by causing animals to aggregate using kelp as bait and then removing them with suction dredges (Wilson and McPeak 1983). Quicklime produces lesions in sea urchin epidermis, but also causes damage to other echinoderms (North 1963, 1966). It is less labor intensive than other urchin removal techniques (Wilson and McPeak 1983). As discussed in Section 2.4 and elsewhere in this profile, dense stands of understory kelps such as Pterygophora californica can inhibit algal recruitment, so removal of these plants has also been used to increase Macrocystis (Wilson and McPeak 1983). All of these techniques may result in more giant kelp in the area manipulated, if Macrocystis is nearby to provide a source of spores, and if environmental conditions are favorable for giant kelp recruitment and growth. Understory kelps and sea urchins are natural parts of kelp forest communities, and one questions whether the objective of

some of these efforts is to restore the natural giant kelp community or simply to produce more Macrocystis.

In areas where Macrocystis is rare or absent, adults and juveniles have been transplanted to restore populations. In some cases, plants from warmer Mexican waters have been used (North 1972a). As adults are large, transplanting is not an easy task. Adult plants are pried from the bottom, towed slowly behind a boat or kept covered and wet on the deck, and then reattached to weights of various sorts at the transplant site by threading nylon rope through the holdfast and around the weight (North and Neushul 1968, North 1976b). Juveniles are tied to suitable rocks, or to the cut ends of Pterygophora californica stipes (North 1976b). They can also be grown on plastic rings in the laboratory, and then outplanted (North 1976b). If either adults or juveniles remain healthy, the haptera quickly grow over the new substrata. The major problem with transplanting large plants to areas nearly devoid of vegetation has been fish grazing (see Section 4.5). Often, few if any plants survive, and transplanting enough to possibly exceed some minimum kelp biomass necessary for survival is expensive, and logistically difficult.

Microscopic sporophytes can be grown in the laboratory, and then distributed over the bottom where plants are desired (North 1976b). This method requires that suitable microsites be available for attachment and growth, and that other environmental conditions are favorable (Figure 25). Because the proper combination of environmental conditions necessary for kelp recruitment, even in the absence of pollution, may occur infrequently at a particular site (Figure 27), success rates may be low.

Most restoration attempts using these methods have not had suitable controls, or have not simultaneously monitored variables such as light and temperature, so their success is difficult to evaluate. Macrocystis has returned to some areas where these techniques have been used, particularly off Palos Verdes near Los Angeles, and Point Loma near San Diego. At Point Loma, the recovery began after the sewer outfall was extended into deeper



water, and at Palos Verdes, it began coincident with a general improvement in discharged water quality and a large increase in sea urchin fishing (see Sewer Discharge above, and Wilson 1982). In this case, the significance of restoration efforts relative to the other environmental changes that may have contributed to community recovery will probably never be known.

Macrocystis can now be easily grown from spore to small juvenile sporophyte (Figure 1) in the laboratory, so it is feasible to use these stages in restoration as North (1976b) has done with microscopic sporophytes. Dean et al. (1983) and Dean and Deysher (1983) have also used gametophytes and microscopic sporophytes for large-scale field experiments. In theory, the easiest method of introducing kelp is to release spores into the area by attaching mesh bags with fertile sporophylls to the bottom. Whether plants eventually result from this procedure will depend on a variety of factors that can affect the small stages of Macrocystis (Figure 25 and see Chapter 5).

#### 6.6.2 Creating New Kelp Forests

The potential for producing large amounts of fuel such as methane from giant kelp (North 1977, Wise et al. 1977), and the real or potential loss of kelp forests as a result of man's activities (such as at SONGS; see Section 6.5.4) has stimulated recent attempts to establish giant kelp monocultures or communities. An initial effort to produce the former was tried offshore from southern California. A structure with an area of 0.25 acres (referred to as the quarter-acre module) was moored in deep water, and planted with adult Macrocystis. Nutrients were increased by pumping up deep water (Gerard pers. comm.). Design problems, currents, and even a large sea urchin recruitment contributed to the failure of the project, and the structure was eventually lost. Neushul and Harger (in press) have established a forest of 700 adult plants on a nearshore sand bottom near Santa Barbara. Plants are anchored by putting the holdfasts in mesh bags filled with gravel, and the effects of density and fertilization on productivity are being evaluated (see Section 4.3.2.1).

For fuel production to be cost effective, Macrocystis would have to be grown on a very large scale. Assuming engineering and biological problems could be solved, monocultures of Macrocystis or other kelps covering many square kilometers of the ocean may have significant impacts on water quality and perhaps even climate, as well as on other uses of the ocean such as shipping (Hruby 1978). These issues remain to be resolved.

Natural stand size could be increased in nearshore areas where present communities are limited in size only by lack of hard substrata. This could be done by simply providing solid substrata such as rock. This has already been done inadvertently in some areas such as Goleta Bay near Santa Barbara, where the kelp forest has extended into a shallow sandy area. In this instance, rock covering a sewage discharge pipeline that goes from the beach through the sand provided the suitable substrata (Foster pers. obs.). Giant kelp forests have also been created in the middle of large sandy areas by placing rocks to form large artificial reefs (Davis et al. 1982). In cases where man's activities threaten or have caused the destruction of local kelp communities, such reefs are a possible means of compensation (Grove 1982). Southern California Edison Company, in conjunction with the California Department of Fish and Game, recently placed a reef (Pendleton artificial reef) for this purpose near Oceanside, north of San Diego (Grove 1982, Grant et al. 1982). To date, over 3 years after construction, giant kelp has not become established on the reef, and adult Macrocystis and Pterygophora californica transplanted to the reef have been severely damaged by fish grazing and storms (LOSL 1983). The slow development has probably also resulted from the early dominance of the substrata by particular invertebrates (see Section 4.4.2.3), precipitous relief of the reef, and the relatively long distance from a source of spores and larvae (LOSL 1983).

The objectives of most prior artificial reefs and reef research have been fish attraction and fisheries enhancement, and it appears that the design and placement of reefs for creating entire kelp forests is a more complex problem. Based

on experience with Pendleton Artificial Reef and a review of other reef and various succession studies, timing of placement, proximity to natural kelp stands, and physical relief appear particularly important to rapid forest development (LOSL 1983). Reefs should probably be "seeded" with Macrocystis spores soon after placement, and may have to be further manipulated at various times (e.g., remove grazers, add particular predators) if rapid community development and a persistent Macrocystis population are desired (LOSL 1983). It must also be recognized that all present and future efforts to create Macrocystis monocultures or communities involve changes in, or destruction of, portions of other communities such as oceanic or sand bottom. Obstructions on an otherwise level bottom may also obstruct trawls.

The first attempt to create a "contained" kelp forest is currently underway in Monterey, California. An indoor tank 9-m deep holding over 1,000,000 liters of sea water was constructed as part of the Monterey Bay Aquarium in Monterey (Martin pers. comm.). This tank, with its upper surface open to the sky and sea water supplied by a large flow-through system, houses a giant kelp forest community that, given the tank size and flow rates, is hoped to be self-sustaining. For the first time, people are able to view the community directly without diving. The facility provides excellent opportunities for education and research.

## 6.7 ENDANGERED SPECIES

The gray whale, brown pelican, and sea otter, all found in and around kelp forests (see Section 4.6.2.2), are currently listed as threatened or endangered. The former two species are common in many other habitats, and populations of both are recovering now that hunting (in the case of the gray whale), and the use of DDT (in the case of the brown pelican) have been reduced (see discussion in Section 4.6.2.2). They will not be discussed further.

Sea otters are more intimately associated with kelp forests, and their management has been more controversial. This is partly because otter foraging has

significant impacts on particular fisheries, because sea otters are very attractive to most people, and because the animal and the fisheries are currently managed by different agencies. As a result of the Marine Mammal Protection Act, the U.S. Fish and Wildlife Service is responsible for the sea otter, with the goal of developing optimal population sizes of this animal consistent with maintenance of the "health" and "stability" of the ecosystem. The California Department of Fish and Game is also responsible for the ecosystem, organisms other than mammals, and fisheries. One view of the management problem is stated by Hardy et al. (1982): "If one has a legally mandated responsibility to manage shellfish fisheries for maximum sustainable yield and concurrently manages a shellfish predator, the sea otter, for an optimum sustainable population, then obviously a managerial dilemma exists. The superimposition of a higher managerial authority may add further problems when the latter's prime concern is the predator."

On the fisheries side of the argument, there is good evidence that the expanding sea otter population has eliminated the commercial abalone fishery within the otter's present range, and has nearly eliminated sport fisheries for abalone, Pismo clams, and crabs (Miller and Geibel 1973, Stephenson 1977, Hardy et al. 1982; but see Estes and Van Blaricom in press, for alternative interpretations). As the population expands or as individuals are translocated to other areas, sea otters may have further impacts on these fisheries as well as those for lobsters to the south, and Dungeness crabs to the north. However, Van Blaricom (in press) points out that sea otter foraging may enhance the commercial kelp harvest, and may increase certain fin-fish stocks and other kelp-associated species. On the other side of the argument, the sea otter population in California may still be threatened with extinction. Population size appears to have leveled off within its present range (see Section 4.6.2.2). There is a debate over whether the population is at carrying capacity within its present range, and Van Blaricom and Jameson (1982) suggested that the present population could be threatened if a large

oil spill occurred. If sea otter population size and range were to be controlled in some way, the techniques for containment have not been resolved. In addition to these problems, both management agencies must contend with political pressure from special-interest groups.

The sea otter-shell fishery controversy is reviewed in Cicin-Sain et al.

(1982) and in our opinion, this and many other controversies related to sea otters are discussed well in the popular article by Pleschner (1984). The sea otter population is, at present, still fully protected while decisions on possible translocation to other sites, zonal management, etc. remain to be made.

## CHAPTER 7

### SUMMARY

*Usually it seems to be true that when even the most definitely apparent cause-effect situations are examined in the light of wider knowledge, the cause-effect aspect comes to be seen as less rather than more significant, and the statistical or relational aspects acquire larger importance. Steinbeck (1962).*

#### 7.1 OVERVIEW AND GENERALIZATIONS

Darwin's (1860) early observations and subsequent studies by others all agree that giant kelp forests are exceptional biological entities; the abundance and diversity of life associated with structurally complex and highly productive Macrocystis populations are obvious to anyone who swims through one of these stands on a clear day. In the preceding chapters, we described the composition, distribution, and abundance of organisms in giant kelp forests, the factors that affect community composition, what we consider to be lacking in our understanding of the ecology of these communities, and necessary approaches for future studies.

Kelp forest communities are found relatively close to shore along the open coast, and are influenced by local coastal processes as well as large-scale oceanographic events. Thus, a large number of factors can affect community structure and dynamics at a variety of spatial and temporal scales. Changing currents and water masses affect temperature, nutrient availability, and dispersal of spores, larvae, and adults. Large-scale (geographic) changes in temperature (and perhaps other factors; see Chapter 5) and the late 1950's and recent "El Nino" warm-water events (see Sections 2.2.3 and 2.2.5) are examples of phenomena that may affect the community over a large area

(i.e., the entire range of Macrocystis pyrifera). Regional differences in current patterns, exposure to swell, and even degree of pollution due to sewage, can affect the community on a smaller scale (e.g., southern California). At a third level, very local differences in terrestrial runoff, substrata, exposure to swell, etc. result in great differences among and within stands over time. Finally, a variety of abiotic factors, some of which are influenced by the organisms themselves (e.g., shading by Pterygophora californica), and biotic factors affect distribution and abundance within a particular stand.

The influence of large-scale phenomena are most difficult to determine because they are difficult or impossible to examine experimentally (Chapter 5). Moreover, processes at all levels may affect population characteristics on a very local scale. The current warm oceanographic period that coincided with record winter storms in 1982-83 is an example of the problem. Numerous changes in kelp forests are now commonly being attributed to changes in water characteristics associated with "El Nino" conditions, but prior to and during these changes, associated storms drastically reduced Macrocystis abundance in California. Therefore, without site-specific demographic studies, the relative importance of these events to the present

condition of particular forests will probably be confused, and correlations with one event or the other could be misleading. Good descriptive studies at a variety of sites, combined with experimental tests of hypotheses and demographic analyses that include monitoring of environmental variables, appear most appropriate for unravelling the complexities of kelp forest ecology. However, even this approach can be confounded by historical events, making the interpretation of present patterns difficult (Dayton and Tegner 1984a).

Listed below are generalizations about the ecology of giant kelp forests that have emerged from our review of the literature, along with suggestions for future studies. For reasons discussed at length in Chapter 5, these generalizations should be considered working hypotheses. They are made in the context of within the geographic range of Macrocystis pyrifera and within the limits of temperature, salinity, nutrients, and light necessary for giant kelp to persist. They apply to the entire life histories of the species involved.

1. The primary requirement for the existence of a kelp forest is hard substrata (Chapter 2). Lack of hard substrata commonly accounts for the absence of the community within depths, and often determines the deeper, offshore boundary of the community. More studies are needed on the effects of sedimentation and burial on community structure and dynamics.

2. Extreme water motion associated with storms is very important to community structure in central California, and occasionally important in southern California (Chapters 2 and 3). Storms commonly remove canopies and entire plants, can directly or indirectly lead to the invasion and proliferation of species other than Macrocystis, and may determine the shallow, inshore boundary of giant kelp distribution. Water motion also has important effects on the abundance and behavior of other species. Studies are needed to determine the relationship of holdfast structure, frond abundance, and frond size to mortality of Macrocystis during periods of extreme water motion.

3. Local differences in light, caused by changes in abiotic conditions and, more especially, by various canopy layers, have a profound effect on algal growth and recruitment and probably the deeper, offshore boundary of giant kelp distribution (Chapters 2 and 3). Coordinated laboratory and field studies of the light requirements for species other than Macrocystis are needed, as are studies of the relationship between variations in light characteristics and the distribution of plant species within a kelp forest.

4. Variability in temperature and nutrients affects community structure, particularly in southern California (Chapter 2). The effects of these abiotic factors on organisms other than Macrocystis need further study.

5. Spore and larval dispersal are important to population and community structure (Chapters 3, 4 and 5). Studies of dispersal and its effects on community structure and dynamics are few and difficult to do, but essential to our understanding of kelp forest ecology.

6. Some grazers, particularly sea urchins, have large, local effects on the community by removing algae and preventing recruitment (Chapters 3 and 4). Grazers may alter species assemblages, allowing invasion and dominance of species different from those consumed. More information is needed on the distribution and abundance of sea urchins within areas and among broader areas of coastline to provide a context for their effects. Information is also needed on the effects of grazers other than sea urchins (e.g., small crustaceans, Patiria miniata).

7. Sea otters cause reductions in invertebrate densities, particularly those of sea urchins and abalone (Chapters 4 and 5); reductions in the numbers of sea urchins can cause an increase in kelp and other foliose algae. The spatial scale of these increases will vary depending on the distribution, abundance, and behavior of sea urchins prior to their reduction. The relationship between sea otter foraging in California and the "health" and "stability" of kelp communities needs to be examined in both the general and local contexts of grazer effects without otters,

the effects of other urchin predators, and the influence of man (aboriginal and modern).

8. Man may have had a profound impact on kelp forests through the historical hunting of mammals, and has had a recent impact by discharging wastes in southern California (Chapters 4 and 6).

The above generalizations are a subset of the factors listed in Table 1, and cover a subset of possible scales of effects outlined in Figure 26; their relative importance varies locally and on different spatial and temporal scales. This suggests that single factors and simple cause-effect relationships will never explain or predict kelp forest community structure. What seems probable are typologies where the relative influence of various factors are assigned to different "types" of forests at different spatial and temporal scales. Thus, water motion may be most important to the structure of giant kelp communities growing on relatively soft rock and exposed to extreme water motion (e.g., Sandhill Bluff, Section 3.3.1 and Figure 5). Sites under these conditions may form one site type. Dispersal and light reduction may be important on the scale of meters, but not tens of meters, to the ecology of stands of understory kelps. Extreme water motion is important on the scale of tens of years but not years.

Such a classification scheme, emphasizing the relationships between sites, scales and factors, is similar to that in an analysis of variance, and would help remove some of the confusion that results from mixing different scales and from generalizing about "kelp forests" from one "kelp forest." It would also provide a more rigorous context for future investigations (for a general discussion of this kind of organization see Bateson 1972, pages 279-308, and 1979, Chapter 7). More thorough descriptive studies at a variety of different sites and spatial scales are needed for development of such a system, but it may be worthwhile to attempt a tentative classification based on our present information.

There appear to be three main differences between temperate subtidal reefs

with and without Macrocystis: giant kelp increases three-dimensional structure by providing living microhabitats such as holdfasts and surface canopy that are reduced or unavailable where giant kelp is absent. Macrocystis also provides increased productivity and, thirdly, the majority of this production is used as detritus (Chapters 3 and 4).

The quantities of drift kelp, both within kelp forests and in other communities such as sandy beaches, and the high abundances and diversity of organisms within forests that can use this drift and detrital material (perhaps directly with little or no prior degradation and energy loss through microbial decomposition), all suggest that Macrocystis stimulates the development of food webs based on detritus (Chapter 3). Further studies of the effects of habitats created by Macrocystis on the remainder of the community, and of differences in detritus versus plankton feeding among assemblages in areas with and without giant kelp, may thus reveal important structural and functional differences between Macrocystis and other nearshore reef communities.

## 7.2 MANAGEMENT RECOMMENDATIONS

Management of kelp forests is hampered by site-specific community differences, lack of information about the causes of these differences, conflicting uses of the community, and pressures from special-interest groups (Chapter 6). Even if the latter three problems are solved, it is clear that evaluations of the effects of proposed activities such as new sewer outfalls will still have to be based on local studies of the particular forest likely to be impacted (Foster et al. 1983). Even with thorough studies, uncertainties about effects will remain.

Kelp forests have recovered where the quality of discharged sewage has improved, or when the locations of outfalls have been changed (Section 6.5.5). It is also true that many direct and probably indirect changes in kelp forest populations are caused by overfishing (Section 6.6.2). On the other hand, although kelp forest restoration attempts are still in the research phase, it appears that this form of management is, and will continue

to be, extremely labor and time intensive, and may be impossible to implement on a large scale. This all suggests that the most effective management is preventing degradation rather than attempting local cures after degradation has occurred. Thus, management via more stringent water quality standards for existing and future ocean discharges of all sorts, and via fishing regulations that do not allow drastic population reductions before significant regulation occurs, is most appropriate and probably essential to natural restoration and the prevention of future resource losses.

### 7.3 RESEARCH NEEDS

We have recommended needed research in a number of places in the profile, particularly in Chapter 5 and in the generalizations above. These suggestions are generally in accord with those of others who work in kelp forests. At a 1979 meeting of kelp forest biologists (Anon 1979), participants were asked to

rank various basic and applied research areas. Basic population studies (recruitment, growth, mortality, reproduction) of "important" kelp forest organisms, studies of physical processes that structure kelp ecosystems, and the functional role of biological processes such as competition and predation received the highest rankings for basic research. Studies of the biological and socio-economic consequences of possible sea otter management alternatives, multi-species approaches to biological and economic modeling, and stock enhancement received the highest ranking among applied research needs.

Research needs will change, but these suggested studies, done and interpreted in the context of site types and spatial and temporal scales outlined above, would certainly improve our understanding of kelp forest communities and help solve some of the problems associated with man's use of them.

## REFERENCES

### 1. PUBLICATIONS

- Abbott, I.A., and G. J. Hollenberg. 1976. Marine algae of California. Stanford University Press, Stanford, Calif. 827 pp.
- Agardh, C.A. 1820. Species algarum... Vol. 1, Part 1. Lund. 1-168.
- Agardh, C.A. 1839. Revision der Algengattung Macrocystis. Nova Acta Acad. Cae. Leop. 19:281-317.
- Agegian, C., M.S. Foster, and J.S. Heine. In prep. Sea urchin distribution and grazing effects in a swell-exposed Nereocystis forest.
- Ainley, D.G. 1976. The occurrence of sea birds in the coastal region of California. West. Birds 5:33-68.
- Ainley, D.G., and G.A. Sanger. 1979. Trophic relations of seabirds in the northeastern Pacific Ocean and Bering Sea. Pages 95-122 in J.C. Bartonek and D.N. Nettleship, eds. Conservation of marine birds of northern North America. U.S. Fish Wildl. Serv. Wildl. Res. Rep. 11.
- Ainley, D.G., D.F. Anderson, and P.R. Kelly. 1981. Feeding ecology of marine cormorants in the southwestern North America. Condor 63:120-131.
- Aleem, A.A. 1956. Quantitative underwater study of benthic communities inhabiting kelp beds off California. Science 123:183.
- Aleem, A.A. 1973. Ecology of a kelp bed in southern California. Bot. Mar. 16:83-95.
- Allen, A.A., R.S. Schlueter, and P.G. Mikolaj. 1970. Natural oil seepage at Coal Oil Point, Santa Barbara, California. Science 170:974-977.
- Ambrose, R.F., and B.V. Nelson. 1982. Inhibition of giant kelp recruitment by an introduced brown alga. Bot. Mar. 25:265-267.
- Ames, J.A., and G.V. Morejohn. 1980. Evidence of white shark, Carcharodon carcharias attacks on sea otters, Enhydra lutris. Calif. Fish Game 66:196-209.
- Anderson, E.K., and W.J. North. 1966. In situ studies of spore production and dispersal in the giant kelp Macrocystis. Proc. Int. Seaweed Symp. 5:73-86.
- Andrew, N.L., and J.H. Choat. 1982. The influence of predation and conspecific adults on the abundance of juvenile Evechinus chloroticus (Echinoidea: Echinometridae). Oecologia 54:80-87.
- Andrews, H.L. 1945. The kelp beds of the Monterey region. Ecology 26:24-37.
- Andrews, J.H. 1977. Observations on the pathology of seaweeds in the Pacific Northwest. Can. J. Bot. 55:1019-1027.
- Angell, T., and K.C. Balcomb. 1982. Marine birds and mammals of Puget Sound. Puget Sound Books, Seattle, Wash. 145 pp.
- Annett, C., and R. Perotti. 1984. Foraging behavior and prey selection of the leather seastar Dermasterias imbricata. Mar. Ecol. Prog. Ser. 14:197-206.



- Anonymous. 1958. The marine fish catch of California. Calif. Dep. Fish Game Fish Bull. 105:1-104.
- Anonymous. 1979. Kelp ecosystem forum proceedings. University of California, San Diego, September 13-14, 1979. California Sea Grant College Program, La Jolla. Mimeo. Rep. 22 pp.
- Ashmole, N.P. 1971. Seabird ecology and the marine environment. Pages 223-286 in D.S. Farner, J.R. King, and K.C. Parkes, eds. Avian biology, Vol. 1. Academic Press, New York.
- Ayling, A.M. 1981. The role of biological disturbance in temperate subtidal encrusting communities. Ecology 62:830-847.
- Baldridge, A. 1972. Killer whales attack and eat a grey whale. J. Mammal. 53:898-900.
- Barilotti, D.C. 1980. Genetic considerations and experimental design of outplanting studies. Pages 10-18 in I.A. Abbott, M.S. Foster, and L.F. Eklund, eds. Pacific seaweed aquaculture. California Sea Grant College Program, University of California, La Jolla.
- Barilotti, D.C., and W. Silverthorne. 1972. A resource management study of Gelidium robustum. Proc. Int. Seaweed Symp. 7:255-261.
- Barilotti, D.C., R.H. McPeak, and P.K. Dayton. In press. Effects of commercial kelp harvesting on Macrocystis haptera growth and plant survivorship. Calif. Fish Game.
- Barrales, H., and C.S. Lobban. 1975. The comparative ecology of Macrocystis pyrifera with emphasis on the forests of Chubut, Argentina. J. Ecol. 63:657-677.
- Bascom, W., ed. 1983. The effects of waste disposal on kelp communities. Southern California Coastal Water Research Project, Long Beach. 328 pp.
- Bateson, G. 1972. Steps to an ecology of mind. Chandler Publ. Co., San Francisco. 545 pp.
- Bateson, G. 1979. Mind and nature. E.P. Dutton, New York. 238 pp.
- Bedford, A.P., and P.G. Moore. 1984. Macrofaunal involvement in the sublittoral decay of kelp debris: the detritivore community and species interactions. Estuarine Coastal Shelf Sci. 18:97-111.
- Benech, S.V. 1980. Observations of the sea otter, Enhydris lutris, population between Point Buchen and Rattlesnake Creek, San Luis Obispo, California. January through December, 1980. ECOMAR Report VII-5-80. ECOMAR, Inc. Santa Barbara, Calif.
- Bernstein, B.B., and N. Jung. 1979. Selective pressures and coevolution in a kelp canopy community in southern California. Ecol. Monogr. 49:335-355.
- Bernstein, B.B., and R.W. Welsford. 1982. An assessment of feasibility of using high-calcium quicklime as an experimental tool for research into kelp bed/sea urchin ecosystems in Nova Scotia. Can. Tech. Rep. Fish. Aquat. Sci. 968:1-51.
- Black, R. 1974. Some biological interactions affecting intertidal populations of the kelp Egregia laevigata. Mar. Biol. (Berl.) 28:189-198.
- Bolin, R.L. 1938. Reappearance of the southern sea otter along the California coast. J. Mammal. 19:301-303.
- Booolootian, R.A. 1961. The distribution of the California sea otter. Calif. Dep. Fish Game 47E83:287-292.
- Bowden, G. 1981. Coastal aquaculture law and policy: a case study of California. Westview Press, Boulder, Colo. 241 pp.
- Bray, R.N. 1981. Influence of water currents and zooplankton densities on daily foraging movements of blacksmith, Chromis punctipinnis, a planktivorous reef fish. U.S. Natl. Mar. Fish. Serv. Fish. Bull. 78:829-841.
- Bray, R.N., and A.W. Ebeling. 1974. Food, activity and habitat of three

- picker-type microcarnivorous fishes in the kelp forests off Santa Barbara, California. U.S. Natl. Mar. Fish. Serv. Fish. Bull. 731:815-829.
- Bray, R.N., and M.A. Hixon. 1978. Night-shocker: predatory behavior of the Pacific electric ray (Torpedo californica). Science 200:333-334.
- Bray, R.N., A.C. Miller, and G.G. Geesey. 1981. The fish connection: a trophic link between planktonic and rocky reef communities. Science 214:204-205.
- Breda, V.A. 1982. Composition, abundance and phenology of foliose red algae associated with two Macrocystis pyrifera forests in Monterey Bay, California. Master's Thesis, San Jose State University, Calif. 67 pp.
- Breen, P.A., and K.H. Mann. 1976. Destructive grazing of kelp by sea urchins in eastern Canada. J. Fish. Res. Board Can. 33:1278-1283.
- Breen, P.A., T.A. Carson, J.B. Foster, and E.A. Stewart. 1982. Changes in subtidal community structure associated with British Columbia sea otter transplants. Mar. Ecol. Prog. Ser. 7:13-20.
- Breitburg, D.L. 1984. Residual effects of grazing: inhibition of competitor recruitment by encrusting coralline algae. Ecology 65:1136-1143.
- Briggs, J.C. 1974. Marine zoogeography. McGraw-Hill Book Co., New York. 475 pp.
- Broenkow, W., and W. Smethie. 1978. Surface circulation and replacement of water in Monterey Bay. Estuarine Coastal Mar. Sci. 6:583-603.
- Brostoff, W.N. 1977. A taxonomic revision of the giant kelp Macrocystis in Southern California based on morphometric transplant studies. Master's Thesis, San Diego State University, Calif. 75 pp.
- Burge, R.T., and S.A. Schultz. 1973. The marine environment in the vicinity of Diablo Cove with special reference to abalones and bony fishes. Calif. Dep. Fish Game. Mar. Res. Tech. Rep. 19. 433 pp.
- Burnett, R. 1971. DDT residues: distributions of concentrations in Emerita analoga (Stimpson) along coastal California. Science 174:606-608.
- Cailliet, G.M., and R.N. Lea. 1977. Abundance of the "rare" zoarcid, Maynea californica Gilbert, 1915, in the Monterey Canyon, Monterey Bay, California. Calif. Fish Game 63:253-261.
- Carr, M.H. 1983. Spatial and temporal patterns of recruitment of young-of-the-year rockfishes (Genus Sebastes) into a central California kelp forest. Master's Thesis, San Francisco State University, Calif. 104 pp.
- Castilla, J.C., and C.A. Moreno. 1982. Sea urchins and Macrocystis pyrifera: experimental test of their ecological relations in southern Chile. Pages 257-263 in J.M. Lawrence, ed. Echinoderms: proceedings of the international conference, Tampa Bay. A.A. Balkema, Rotterdam.
- Chan, G.L. 1973. Subtidal mussel beds in Baja California with a new record size for Mytilus californianus. Veliger 16:239-240.
- Chapman, A.R.O. 1981. Stability of sea urchin-dominated barren grounds following destructive grazing of kelp in St. Margaret's Bay, eastern Canada. Mar. Biol. (Berl.) 62:307-311.
- Chapman, A.R.O. 1984. Reproduction, recruitment and mortality in two species of Laminaria in southwest Nova Scotia. J. Exp. Biol. Ecol. 78:99-109.
- Chapman, A.R.O., and J.S. Craigie. 1977. Seasonal growth in Laminaria longicruris: Relations with dissolved inorganic nutrients and internal reserves of nitrogen. Mar. Biol. (Berl.) 40:197-205.
- Chapman, A.R.O., and J.E. Lindley. 1980. Seasonal growth of Laminaria

- solidungula in the Canadian high arctic in relation to irradiance and dissolved nutrient concentrations. *Mar. Biol. (Berl.)* 57:1-5.
- Chapman, V.J. 1970. *Seaweeds and their uses*, 2nd ed. Methuen and Co., Ltd., London. 304 pp.
- Charters, A.C., M. Neushul, and D.C. Barilotti. 1969. The functional morphology of Eisenia arborea. *Proc. Int. Seaweed Symp.* 6:89-105.
- Choat, J.H. 1982. Fish feeding and the structure of benthic communities in temperate waters. *Annu. Rev. Ecol. Syst.* 13:423-449.
- Choat, J.H., and D.R. Schiel. 1982. Patterns of distribution and abundance of large brown algae and invertebrate herbivores in subtidal regions of northern New Zealand. *J. Exp. Mar. Biol. Ecol.* 60:129-162.
- Cicin-Sain, B., P.M. Grifman, and J.B. Richards. 1982. Social science perspectives on managing conflicts between marine mammals and fisheries. University of California Cooperative Extension, San Luis Obispo. 347 pp.
- Clarke, T.A. 1970. Territorial behavior and population dynamics of a pomacentrid fish, the garibaldi, Hypsypops rubicunda. *Ecol. Monogr.* 40:189-212.
- Clarke, T.A. 1971. Territory boundaries, courtship, and social behavior in the garibaldi, Hypsypops rubicunda (Pomacentridae). *Copeia* 2:295-299.
- Clarke, W.D., and M.N. Neushul. 1967. Subtidal ecology of the southern California coast. Pages 29-42 in T.A. Olson and F.J. Burgess, eds. *Pollution and marine ecology*. J. Wiley and Sons, New York.
- Clendenning, K.A. 1971a. Phytoplankton as light-absorbing agents in the La Jolla kelp bed. *Nova Hedwigia* 32:255-258.
- Clendenning, K.A. 1971b. Organic productivity in kelp areas. *Nova Hedwigia* 32:259-263.
- Clendenning, K.A. 1971c. Photosynthesis and general development in Macrocystis. *Nova Hedwigia* 32:169-190.
- Connell, J.H. 1972. Community interactions on marine rocky intertidal shores. *Annu. Rev. Ecol. Syst.* 3:169-192.
- Connell, J.H. 1974. Ecology: field experiments in marine ecology. Pages 21-54 in R.N. Mariscal, ed. *Experimental marine biology*. Academic Press, New York.
- Connell, J.H. 1975. Some mechanisms producing structure in natural communities: a model and evidence from field experiments. Pages 460-490 in M.L. Cody and J.M. Diamond, eds. *Ecology and evolution of communities*. Belknap Press of Harvard Press, Cambridge, Mass.
- Connell, J.H. 1983. On the prevalence and relative importance of interspecific competition: evidence from field experiments. *Am. Nat.* 122:661-696.
- Connell, J.H., and R.O. Slatyer. 1977. Mechanisms of succession in natural communities and their role in community stability and organization. *Am. Nat.* 111:1119-1144.
- Connell, J.W., and W.P. Sousa. 1983. On the evidence needed to judge ecological stability or persistence. *Am. Nat.* 121:789-824.
- Coon, D.A. 1981. Studies of whole plant growth in Macrocystis angustifolia. *Bot. Mar.* 24:19.
- Coon, D.A. 1982. Primary productivity of macroalgae in North Pacific America. Pages 447-454 in O.R. Zaborsky, ed. *CRC handbook of biosolar resources*. CRC Press, Boca Raton, Fla.
- Costa, D.P. 1978. The biological energetics, water and electrolyte balance of the California sea otter Enhydra lutris. Ph.D. Thesis, University of California, Santa Cruz. 75 pp.
- Cousens, R., and M.J. Hutchings. 1983. The relationship between density and mean frond weight in monospecific seaweed stands. *Nature* 301:240-241.

- Cowardin, L.M., V. Carter, F.C. Golet, and E.T. LaRoe. 1979. Classification of wetlands and deepwater habitats of the United States. U.S. Dep. of Interior, Fish and Wildlife Service. Biological Services Program FWS/OBS-79/31. 103 pp.
- Cowen, R.K. 1979. Trophic interactions within a central California kelp forest. Master's Thesis, California State University, Hayward. 69 pp.
- Cowen, R.K. 1983. The effect of sheepshead (Semicossyphus pulcher) predation on red sea urchin (Strongylocentrotus franciscanus) populations: and experimental analysis. *Oecologia* 58:249-255.
- Cowen, R.K., C.R. Agegian, and M.S. Foster. 1982. The maintenance of community structure in a central California giant kelp forest. *J. Exp. Biol. Ecol.* 64:189-201.
- Cox, K.W. 1962. California abalones, family Haliotidae. *Calif. Dep. Fish Game Fish Bull.* 118:1-133.
- Coyer, J.A. 1979. The invertebrate assemblage associated with Macrocystis pyrifera and its utilization as a food source by kelp forest fishes. Ph.D. Thesis, University of Southern California, Los Angeles. 364 pp.
- Coyer, J.A., and A.C. Zaugg-Haglund. 1982. A demographic study of the elk kelp, Pelagophycus porra (Laminariales, Lessoniaceae), with notes on Pelagophycus x Macrocystis hybrids. *Phycologia* 21:399-407.
- Crandall, W.C. 1915. The kelp beds from lower California to Puget Sound. Pages 33-49 plus plates in F.K. Cameron, ed. Potash from kelp. U.S. Dep. of Agric. Rep. 100, Washington, D.C.
- Cross, J.N. 1982. Trends in fin erosion among fishes on the Palos Verdes shelf. Pages 99-110 in W. Bascom, ed. Coastal water research project: biennial report for the years 1981-1982. Southern California Coastal Water Research Project, Long Beach.
- Cupp, E.E. 1943. Marine plankton diatoms of the west coast of North America. University of California Press, Berkeley. 237 pp.
- Dailey, M.D., and R.L. Brownell. 1971. A checklist of marine mammal parasites. Pages 528-589 in S.H. Ridgway, ed. Mammals of the sea, their biology and medicine. Charles C. Thomas, Springfield, Ill.
- Darwin, C. 1860. The voyage of the Beagle. Reprinted in 1962. Anchor Books, Doubleday and Co., Inc., Garden City, New York.
- Daugherty, A.E., and P. Schuyler. 1979. Marine mammals of California. *Calif. Sea Grant Marine Advisory Publ.* 61 pp.
- Davies, D.H. 1968. Statistical analysis of the relation between kelp harvesting and sport fishing in the California kelp beds. Pages 151-212 in W.J. North and C.L. Hubbs, eds. Utilization of kelp-bed resources in southern California. *Calif. Dep. Fish Game Fish Bull.* 139.
- Davis, J., and A. Baldrige. 1980. The bird year, a book for birders. Boxwood Press, Pacific Grove, Calif. 224 pp.
- Davis, N., G.R. Van Blaricom, and P.K. Dayton. 1982. Man-made structures on marine sediments: effects on adjacent benthic communities. *Mar. Biol. (Berl.)* 70:295-303.
- Dawson, E.Y. 1951. A further study of upwelling and associated vegetation along Pacific Baja California, Mexico. *J. Mar. Res.* 10:39-58.
- Dawson, E.Y., and M.S. Foster. 1982. Seashore plants of California. University of California Press, Berkeley. 226 pp.
- Dawson, E.Y., M. Neushul, and R.D. Wildman. 1960. Seaweeds associated with kelp beds along southern California and northwestern Mexico. *Pac. Nat.* 1:1-81.
- Day, R.A. 1983. How to write and publish a scientific paper, 2nd ed. ISI Press, Philadelphia, Pa. 181 pp.

- Day, R.W., and R.W. Osman. 1981. Predation by Patiria miniata (Asteroidea) on bryozoans: prey diversity may depend on the mechanism of succession. *Oecologia* 51:300-309.
- Dayton, P.K. 1971. Competition, disturbance, and community organization: the provision and subsequent utilization of space in a rocky intertidal community. *Ecol. Monogr.* 41:351-389.
- Dayton, P.K. 1973. Dispersion, dispersal and persistence of the annual intertidal alga Postelsia palmaeformis Ruprecht. *Ecology* 54:433-438.
- Dayton, P.K. 1975. Experimental studies of algal canopy interactions in a sea otter-dominated kelp community at Amchitka Island, Alaska. U.S. Natl. Mar. Fish. Serv. Fish. Bull. 73:230-237.
- Dayton, P.K., and M.J. Tegner. 1984a. The importance of scale in community ecology: a kelp forest example with terrestrial analogs. Pages 457-481 in P.W. Prince, C.N. Slobodchikoff, and W.S. Gand, eds. *Novel approaches to interactive systems*. J. Wiley and Sons, New York.
- Dayton, P.K., and M.H. Tegner. 1984b. Catastrophic storms, El Nino, and patch stability in a southern California kelp community. *Science* 224:283-285.
- Dayton, P.K., V. Currie, T. Gerrodette, B.D. Keller, R. Rosenthal, and D. Ven Tresca. 1984. Patch dynamics and stability of some California kelp communities. *Ecol. Monogr.* 54:253-289.
- Dean, T.A. Manuscript. Kelp bed irradiation. The temporal and spatial distribution of underwater quantum irradiation in a southern California kelp bed. Kelp Ecology Project, Encinitas, Calif. n.p.
- Dean, T.A., and L.E. Deysher. 1983. The effects of suspended solids and thermal discharges on kelp. Pages 114-135 in W. Bascom, ed. *The effects of waste disposal on kelp communities*. Southern California Coastal Water Research Project, Long Beach.
- Dean, T.A., and F.R. Jacobsen. In press. The growth of juvenile Macrocystis pyrifera (Laminariales) in relation to environmental factors. *Mar. Biol.* (Berl.)
- Dean, T.A., L. Deysher, K. Thies, S. Lagos, F. Jacobsen, and L. Bost. 1983. The effects of the San Onofre Nuclear Generating Station (SONGS) on the giant kelp Macrocystis pyrifera: final preoperational monitoring report. Marine Review Committee, Inc., Encinitas, Calif. n.p.
- Dean, T.A., S.C. Schroeter, and J.D. Dixon. 1984. Effects of grazing by two species of sea urchins (Strongylocentrotus franciscanus and Lytechinus anamesus) on recruitment and survival of two species of kelp (Macrocystis pyrifera and Pterygophora californica). *Mar. Biol.* (Berl.) 78:301-313.
- DeBoer, J.A. 1981. Nutrients. Pages 356-392 in C.S. Lobban and M.J. Wynne, eds. *The biology of seaweeds*. University of California Press, Berkeley.
- DeMartini, E.E., and M.E. Anderson. 1980. Comparative survivorship and life history of painted greenling (Oxylebius pictus) in Puget Sound, Washington and Monterey Bay, California. *Biol. Fish.* 5:33-47.
- Denley, E.J., and P.K. Dayton. In press. Competition between macroalgae in M.M. Littler and D.S. Littler, eds. *Handbook of phycological methods: ecological methods for macroalgae*. Cambridge University Press, Cambridge, England.
- Devinsky, J.S., and P.D. Kirkwood. 1974. Algae associated with kelp beds of the Monterey Peninsula, California. *Bot. Mar.* 17:100-106.
- Devinsky, J.S., and L.A. Volse. 1978. Effects of sediments on the development of Macrocystis pyrifera gametophytes. *Mar. Biol.* (Berl.) 48:343-348.
- DeWreede, R.E. 1983. Sargassum muticum (Fucales, Phaeophyta): regrowth and

- interaction with Rhodomelia larix (Ceramiales, Rhodophyta). Phycologia 22:153-160.
- DeWreede, R.E. 1984. Growth and age class distribution of Pterygophora californica (Phaeophyta). Mar. Ecol. Prog. Ser. 19:93-100.
- Deysher, L.E., and T.A. Dean. In press. Critical irradiance levels and the interactive effects on quantum irradiance and quantum dose on gametogenesis in the giant kelp, Macrocystis pyrifera. J. Phycol.
- Deysher, L.E., and T.A. Norton. 1982. Dispersal and colonization in Sargassum muticum (Yendo) Fensholt. J. Exp. Mar. Biol. Ecol. 56:179-195.
- Dieckmann, G.S. 1980. Aspects of the ecology of Laminaria pallida (Grev.) off the Cape Peninsula (South Africa). I. Seasonal growth. Bot. Mar. 23:579-585.
- Dixon, J., S.C. Schroeter, and J. Kastendiek. 1981. Effects on the encrusting bryozoan Membranipora membranacea on the loss of blades and fronds by the giant kelp Macrocystis pyrifera (Laminariales). J. Phycol. 17:341-345.
- Domning, D.P. 1978. Sirenian evolution in the North Pacific Ocean. University of California Press, Berkeley. 176 pp.
- Druehl, L.D. 1970. The pattern of Laminariales distribution in the north-east Pacific. Phycologia 9:237-247.
- Druehl, L.D. 1978. The distribution of Macrocystis integrifolia in British Columbia as related to environmental parameters. Can. J. Bot. 56:69-79.
- Druehl, L.D. 1979. On the taxonomy of California Laminaria (Phaeophyta). J. Phycol. 15:337-338.
- Duggins, D.O. 1980. Kelp beds and sea otters: an experimental approach. Ecology 61:447-453.
- Duggins, D.O. 1981a. Sea urchins and kelp: the effects of short-term changes in urchin diet. Limnol. Oceanogr. 26:391-394.
- Duggins, D.O. 1981b. Interspecific facilitation in a guild of benthic marine herbivores. Oecologia 48:157-163.
- Duggins, D.O. 1983. Starfish predation and the creation of mosaic patterns in a kelp-dominated community. Ecology 64:1610-1619.
- Dungan, M.L., T.E. Miller, and D.A. Thompson. 1982. Catastrophic decline of a top carnivore in the Gulf of California rocky intertidal zone. Science 216:989-991.
- Dykzeul, J.E., and R.R. Given. 1979. Areas of special biological significance, reconnaissance survey report: Santa Catalina Island, subareas one-four, Los Angeles County. California State Water Resources Control Board, Water Quality Monitoring Rep. 79-b. Sacramento, Calif. 192 pp.
- Ebeling, A.W., and R.N. Bray. 1976. Day versus night activity of reef fishes in a kelp forest off Santa Barbara, California. U.S. Natl. Mar. Fish. Serv. Fish. Bull. 74:703-717.
- Ebeling, A.W., W. Werner, F.A. DeWitt, and G.M. Cailliet. 1971. Santa Barbara oil spill: short-term analysis of macroplankton and fish. U.S. Environ. Prot. Agency, Water Pollut. Control Res. Ser. 15080EAL02/71. 68 pp.
- Ebeling, A.W., R.J. Larson, and W.S. Alevizon. 1980a. Habitat groups and island-mainland distribution of kelp-bed fishes off Santa Barbara, California. Pages 404-431 in D.M. Power, ed. Multi-disciplinary symposium on the California islands. Santa Barbara Mus. Nat. Hist., Santa Barbara, Calif.
- Ebeling, A.W., R.L. Larson, W.S. Alevizon, and R.N. Bray. 1980b. Annual variability of reef-fish assemblages in kelp forests off Santa Barbara, California. U.S. Natl. Mar. Fish. Serv. Fish. Bull. 78:361-377.
- Ebeling, A.W., D.R. Laur, and R.J. Rowley. Manuscript. Severe storm disturbances

- and reversal of community structure in a southern California kelp forest. Department of Biological Sciences, University of California, Santa Barbara. 26 pp.
- Ebert, E.E. 1968. A food habits study of the southern sea otter Enhydra lutris nereis. Calif. Fish Game 54:33-42.
- Ehrlich, P.R., and L.C. Birch. 1967. The "balance of nature" and "population control." Am. Nat. 101:97-107.
- Ellison, J.P., C. Terry, and J.S. Stephens, Jr. 1979. Food resource utilization among five species of embiotocids at King Harbor, California, with preliminary estimates of caloric intake. Mar. Biol. (Berl.) 52:161-169.
- Eppley, R.W., A.F. Carlucci, O. Holm-Hansen, D. Kiefer, J.J. McCarthy, and P.M. Williams. 1972. Evidence for eutrophication in the sea near southern California sewage outfalls, July 1970. Calif. Coop. Oceanic Fish. Invest. Rep. 16:74-83.
- Eschmeyer, W.N., E.S. Herald, and H. Hammann. 1983. A field guide to Pacific coast fishes of North America. Houghton Mifflin Co., Boston, Mass. 336 pp.
- Estes, J.A., and R.J. Jameson. 1983. Summary of available population information on California sea otters. U.S. Dep. of Inter. POCS Tech. Pap. 83-11. 29 pp.
- Estes, J.A., and J.F. Palmisano. 1974. Sea otters: their role in structuring nearshore communities. Science 185:1058-1060.
- Estes, J.A., and P.D. Steinberg. Manuscript. Diving predators, herbivory gradients, and the evolution of kelp. Center for Coastal Marine Studies, University of California, Santa Cruz. n.p.
- Estes, J.A., and G.R. Van Blaricom. In press. Sea otters and shellfisheries. In R.A. Beverton, D. Lavigne, and J. Beddington, eds. Conflicts between marine mammals and fisheries. Allen and Unwin, London.
- Estes, J.A., R.J. Jameson, and A.M. Johnson. 1981. Food selection and some foraging tactics of sea otters. Pages 606-641 in J.A. Chapman and D. Pursley, eds. The worldwide furbearer conference proceedings, Vol. I. Worldwide Furbearer Conference, Inc., Frostburg, Md.
- Estes, J.A., N.S. Smith, and J.S. Palmisano. 1978. Sea otter predation and community organization in the western Aleutian Islands, Alaska. Ecology 59:822-833.
- Fadlallah, Y.H. 1983. Population dynamics and life history of a solitary coral, Balanophyllia elegans, from central California. Oecologia 58:200-207.
- Fager, E.W. 1971. Pattern in the development of a marine community. Limnol. Oceanogr. 16:241-253.
- Fankboner, P.V. 1976. Accumulation of dissolved carbon by the solitary coral Balanophyllia elegans -- an alternative nutritional pathway? Pages 111-116 in G.G. Mackie, ed. Coelenterate ecology and behavior. Plenum Publ., New York.
- Fankboner, P.V., and M.E. de Burgh. 1977. Diurnal exudation of <sup>14</sup>C-labeled compounds by the large kelp Macrocystis integrifolia Bory. J. Exp. Mar. Biol. Ecol. 28:151-162.
- Fankboner, P.V., and L.D. Druehl. 1976. In situ accumulation of marine algal exudate by a polychaete worm (Schizobranchia insignis). Experientia 32:1391-1392.
- Fay, R.C., E.D. Michael, J.A. Vallee, and G.B. Anderson. 1972. Southern California's deteriorating marine environment. California Public Affairs, Claremont College, Calif. 76 pp.
- Feder, H.M., C.H. Turner, and C. Limbaugh. 1974. Observations on fishes associated with kelp beds in southern California. Calif. Dep. Fish Game Fish Bull. 160:1-144.
- Field, E.J., and E.A.C. Clark. 1978. Kelp inventory, 1976, Part 2. The

- Dundras Group, Fisheries Development Rep. 11. British Columbia Ministry of Recreation and Conservation, Marine Resources Branch. n.p.
- Filion-Myklebust, C., and T.A. Norton. 1981. Epidermis shedding in the brown seaweed Ascophyllum nodosum (L.) Les Jolis, and its ecological significance. *Mar. Biol. Lett.* 2:45-51.
- Fisher, E.M. 1939. Habits of the southern sea otter. *J. Mammal.* 54:21-36.
- Fitch, J.E. 1971. Marine food and game fishes of California. University of California Press, Berkeley. 179 pp.
- Fitch, J.E. 1975. Tidepool and nearshore fishes of California. University of California Press, Berkeley. 156 pp.
- Fletcher, R.L. 1980. Studies on the recently introduced brown alga Sargassum muticum (Yendo) Fensholt. III. Periodicity in gamete release and incubation of early germling stages. *Bot. Mar.* 23:425-432.
- Fletcher, R.L., and S.M. Fletcher. 1975. Studies on the recently introduced brown alga Sargassum muticum (Yendo) Fensholt. I. Ecology and reproduction. *Bot. Mar.* 18:149-156.
- Fletcher, W.J., and R.W. Day. 1983. The distribution of epifauna on Ecklonia radiata (C. Agardh) J. Agardh and the effect of disturbance. *J. Exp. Mar. Biol. Ecol.* 71:205-220.
- Follett, W.I., and D.G. Ainley. 1976. Fishes collected by pigeon guillemots, Cephus columba (Pallas), nesting on Southeast Farallon Island, California. *Calif. Fish Game* 62:28-31.
- Foster, M.S. 1972. The algal turf community in the nest of the ocean goldfish Hypsypops rubicunda. *Proc. Int. Seaweed Symp.* 7:55-60.
- Foster, M.S. 1975a. Algal succession in a Macrocystis pyrifera forest. *Mar. Biol. (Berl.)* 32:313-329.
- Foster, M.S. 1975b. Regulation of algal community development in a Macrocystis pyrifera forest. *Mar. Biol. (Berl.)* 32:331-342.
- Foster, M.S. 1982a. The regulation of macroalgal associations in kelp forests. Pages 185-205 in L. Srivastava, ed. *Synthetic and degradative processes in marine macrophytes.* Walter de Gruyter Co., Berlin.
- Foster, M.S. 1982b. Factors controlling the intertidal zonation of Iridaea flaccida (Rhodophyta). *J. Phycol.* 18:285-294.
- Foster, M.S., and J.S. Heine. 1981. Studies of the effects of sea otter foraging on kelp forest communities in central California: Year four. Mimeo Rep. to Calif. Dep. Fish and Game, Sacramento, in fulfillment of Contract No. S-1156. 38 pp.
- Foster, M.S., and R.W. Holmes. 1977. The Santa Barbara oil spill: An ecological disaster? Pages 166-190 in J. Cairns, Jr., K.L. Dickson, and E.E. Herricks eds. *Recovery and restoration of damaged ecosystems.* University Press of Virginia, Charlottesville.
- Foster, M.S., and D. Reed. 1980. Studies of the effects of sea otter foraging on kelp forest communities in central California: Year three. Mimeo Rep. to Calif. Dep. Fish and Game, Sacramento, in fulfillment of Contract No. S-1156. 57 pp.
- Foster, M.S., and W.P. Sousa. In press. Succession in M.M. Littler and D.S. Littler, eds. *Handbook of phycological methods: ecological methods for macroalgae.* Cambridge University Press, Cambridge, England.
- Foster, M.S., A.C. Charters, and M. Neushul. 1971a. The Santa Barbara oil spill. Part 1: Initial quantities and distribution of pollutant crude oil. *Environ. Pollut.* 2:97-113.
- Foster, M.S., M. Neushul, and R. Zingmark. 1971b. The Santa Barbara oil spill. Part 2: Initial effects on intertidal and kelp bed organisms. *Environ. Pollut.* 2:115-134.



- Foster, M.S., C. Agegian, R. Cowen, R. Van Wagenan, D. Rose, and A. Hurley. 1979a. Toward an understanding of the effects of sea otter foraging on kelp forest communities in central California. Final Rep. to U.S. Marine Mammal Commission, Contract No. MM7AC023. National Technical Information Service, Springfield, Va. Publ. PB293891. 60 pp.
- Foster, M.S., R. Cowen, C. Agegian, D. Rose, R. Van Wagenan, and A. Hurley. 1979b. Continued studies of the effects of sea otter foraging on kelp forest communities in central California. Mimeo. Rep. to Calif. Dep. Fish and Game, Sacramento, in fulfillment of Contract No. S-1156. 107 pp.
- Foster, M.S., J. Carter, and D. Schiel. 1983. Ecology of kelp communities. Pages 53-69 in W. Bascom, ed. The effects of waste disposal on kelp communities. Southern California Coastal Water Research Project, Long Beach.
- Foster, M.S., T.A. Dean, and L.E. Deysher. In press. Subtidal techniques in M.M. Littler and D.S. Littler, eds. Handbook of phycological methods: ecological methods for macroalgae. Cambridge University Press, Cambridge, England.
- Frey, H.W. 1971. California's living marine resources and their utilization. California Fish and Game, Sacramento. 148 pp.
- Frye, T. 1918. The age of Pterygophora californica. Publ. Puget Sound Biol. Stn. 2:65-71.
- Fukuyama, A., and J. Nybakken. 1983. Specialized feeding in mitrid gastropods: evidence from a temperate species, Mitrae idae Melville. Veliger 26:96-100.
- Gagne, J.A., K.H. Mann, and A.R.O. Chapman. 1982. Seasonal patterns of growth and storage in Laminaria longicruris in relation to differing patterns of availability of nitrogen in the water. Mar. Biol. (Berl.) 69:91-101.
- Gaines, S.D., and J. Lubchenko. 1982. A unified approach to marine plant-herbivore interactions. 2. Biogeography. Annu. Rev. Ecol. Syst. 13:111-138.
- Gerard, V.A. 1976. Some aspects of material dynamics and energy flow in a kelp forest in Monterey Bay, California. Ph.D. Thesis, University of California, Santa Cruz. 173 pp.
- Gerard, V.A. 1982a. In situ rates of nitrate uptake by giant kelp, Macrocystis pyrifera (L.) C. Agardh, tissue differences, environmental effects, and predictions of nitrogen-limited growth. J. Exp. Mar. Biol. Ecol. 62:211-224.
- Gerard, V.A. 1982b. Growth and utilization of internal nitrogen reserves by the giant kelp Macrocystis pyrifera in a low nitrogen environment. Mar. Biol. (Berl.) 66:27-35.
- Gerard, V.A. 1982c. In situ water motion and nutrient uptake by the giant kelp Macrocystis pyrifera. Mar. Biol. (Berl.) 69:51-54.
- Gerard, V.A., and D.L. Garrison. 1971. Quantitative sampling. Pages 72-77 in J.S. Pearse, ed. A kelp bed as a classroom. Mimeo Rep., Hopkins Marine Station of Stanford University, Monterey, Calif.
- Gerard, V.A., and H. Kirkman. 1984. Ecological observations on a branched loose-lying form of Macrocystis pyrifera (L.) C. Agardh in New Zealand. Bot. Mar. 27:105-109.
- Gerard, V.A., and K.H. Mann. 1979. Growth and production of Laminaria longicruris (Phaeophyta) populations exposed to different intensities of water movement. J. Phycol. 15:33-41.
- Gerrodette, T. 1979. Equatorial submergence in a solitary coral Balanophyllia elegans and the critical life stage excluding the species from shallow water in the south. Mar. Ecol. Prog. Ser. 1:227-235.

- Gerrodette, T. 1981. Dispersal of the solitary coral Balanophyllia elegans by demersal planular larvae. Ecology 62:611-619.
- Ghelardi, R.J. 1971. "Species" structure of the animal community that lives in Macrocystis pyrifera holdfasts. Nova Hedwigia 32:381-420.
- Goff, L.J., and J.C. Glasgow. 1980. Pathogens of marine plants. Center for Coastal Marine Studies, University of California, Santa Cruz. 236 pp.
- Gordon, B.L. 1974. Monterey Bay area: natural history and cultural imprints. Boxwood Press, Pacific Grove, Calif. 202 pp.
- Gotshall, D.W. 1981. Pacific coast inshore fishes. Dai Nippon Printing Co., Japan. 93 pp.
- Gotshall, D.W., and L.L. Laurent. 1979. Pacific coast subtidal marine invertebrates: a fish watchers' guide. Sea Challengers, Los Osos, Calif. 107 pp.
- Grant, J.J., K.C. Wilson, A. Grover, and H. Togstad. 1982. Early development of Pendleton artificial reef. Mar. Fish. Rev. 44:53-60.
- Green, R.H. 1979. Sampling design and statistical methods for environmental biologists. John Wiley & Sons, Inc., New York. 257 pp.
- Grigg, R. 1975. Age structure of a longevous coral: a relative index of habitat suitability and stability. Am. Nat. 109:647-657.
- Grigg, R.W., and R.S. Kiwala. 1970. Some ecological effects of discharged wastes on marine life. Calif. Fish Game 56:145-155.
- Grove, R.S. 1982. Artificial reefs as a resource management option for siting coastal power stations in southern California. Mar. Fish. Rev. 44:24-27.
- Haldorson, L., and M. Moser. 1979. Geographic patterns of prey utilization in two species of surfperch (Embiotocidae). Copeia 1979:567-572.
- Hallacher, L.E. 1977. Patterns of space and food use by inshore rockfishes (Scorpaenidae: Sebastesi) of Carmel Bay, California. Ph.D. Thesis, University of California, Berkeley. 115 pp.
- Hammer, R.M. 1981. Day-night differences in the emergence of demersal zooplankton from a sand substrate in a kelp forest. Mar. Biol. (Berl.) 62:275-280.
- Hammer, R.M., and R.C. Zimmerman. 1979. Species of demersal zooplankton inhabiting a kelp forest ecosystem off Santa Catalina Island, California. Bull. South. Calif. Acad. Sci. 78:199-206.
- Hardy, R., F. Wendell, and J.D. DeMartini. 1982. A status report on California shellfish fisheries. Pages 328-342 in B. Cicin-Sain, P.M. Grifman, and J.B. Richards, eds. Social science perspectives on managing conflicts between marine mammals and fisheries. University of California Cooperative Extension, San Luis Obispo, Calif.
- Harper, J.L. 1977. Population biology of plants. Academic Press, New York. 892 pp.
- Harris, L.G., A.W. Ebeling, D.R. Laur, and R.J. Rowley. 1984. Community recovery after storm damage: a case of facilitation in primary succession. Science 224:1336-1338.
- Harrold, C. 1981. Feeding ecology of the asteroid Pisaster giganteus in a kelp forest system: prey selection, predator-prey interactions, and energetics. Ph.D. Thesis, University of California, Santa Cruz. 163 pp.
- Harrold, C., and D. Reed. In press. Food availability, sea urchin grazing, and kelp forest community structure. Ecology.
- Hart, L.C. 1982. Auxins as plant growth regulators in the marine alga PeLAGOPHYCUS porra (Leman) Setchell (Phaeophyta, Laminariales). Ph.D. Thesis, University of Southern California, Los Angeles. 205 pp.

- Hasegawa, Y., and Y. Sanbonsuga. 1972. Laboratory rearing of laminariaceous plants. Pages 109-116 in I.A. Abbott and M. Kurogi, eds. Contributions to the systematics of benthic marine algae of the North Pacific. Japanese Society of Phycology, Kobe.
- Hedgpeth, J.W. 1957. Marine biogeography. Pages 359-382, 16 figs., 1 plate, in Treatise on marine ecology and paleoecology. Geological Society of America, Memphis.
- Hedgpeth, J.W., and J.J. Gonor. 1969. Aspects of the potential effect of thermal alteration on marine and estuarine benthos. Pages 80-118 in P.A. Krenkel and F.L. Parker, eds. Proceedings of the national symposium on thermal pollution. Vanderbilt University Press, Nashville.
- Heimann, R.F.G., and J.G. Carlisle, Jr. 1970. The California marine fish catch for 1968 and historical review 1916-1968. Calif. Dep. Fish Game Fish Bull. 149:1-70.
- Heimann, R.F.G., H.W. Frey, and P.M. Rodel. 1968. The California marine fish catch for 1966. Calif. Dep. Fish Game Fish Bull. 138:1-76.
- Heine, J.N. 1983. Seasonal productivity of two red algae in a central California kelp forest. J. Phycol. 19:146-152.
- Hennessy, S.L., and G.V. Morejohn. 1977. Acanthocephalan parasites of the sea otter *Enhydra lutris* off coastal California. Calif. Dep. Fish Game 63:268-272.
- Herrlinger, T.J. 1983. The diet and predator-prey relationships of the seastar *Pycnopodia helianthoides* (Brandt) from a central California kelp forest. Master's Thesis, San Jose State University, Calif. 57 pp.
- Hines, A.H. 1982. Coexistence in a kelp forest: size, population dynamics and resource partitioning in a guild of spider crabs (Brachyura, Majidae). Ecol. Monogr. 52:179-198.
- Hines, A., and T. Loughlin. 1980. Observations of sea otters digging for clams at Monterey Harbor, California. U.S. Natl. Mar. Fish. Serv. Fish. Bull. 70:159-163.
- Hines, A.H., and J.S. Pearse. 1982. Abalones, shells, and sea otters: dynamics of prey populations in central California. Ecology 63:547-560.
- Hixon, M.A. 1980. Competitive interactions between California reef fishes of the genus *Embiotica*. Ecology 61:918-931.
- Hobson, E.S. 1973. Diel feeding and migrations in tropical reef fishes. Helgol. Wiss. Meeresunters. 24:361-370.
- Hobson, E.S., and J.R. Chess. 1976. Trophic interactions among fishes and zooplankters near shore at Santa Catalina Island, California. U.S. Natl. Mar. Fish. Serv. Fish. Bull. 74:567-598.
- Hobson, E.S., W.N. McFarland, and J.R. Chess. 1981. Crepuscular and nocturnal activities of California nearshore fishes, with consideration of their scotopic visual pigments and the photic environment. U.S. Natl. Mar. Fish. Serv. Fish. Bull. 79:1-30.
- Hodder, D., and M. Mel. 1978. Kelp survey of the Southern California Bight. Esca-Tech Corp. and Science Applications, Inc. Tech. Rep. Vol. III Report 1.4 to Bureau of Land Management (Year II SCOSC Program), Contract No. AA550-CT6-40. La Jolla, Calif. 105 pp.
- Holmes, R.W., P.M. Williams, and R.W. Eppley. 1967. Red water in La Jolla Bay, 1964-1966. Limnol. Oceanogr. 12:503-512.
- Hooker, J.D. 1847. The botany of the Antarctic voyage of H.M. discovery ships Erebus and Terror. Pages 454-519 in Flora Antarctica. Vol. 2, Algae. Reeve Bros., London.
- Houk, J.L., and J.J. Geibel. 1974. Observations of underwater tool use by the sea otter *Enhydra lutris* Linnaeus. Calif. Dep. Fish Game 60:207-208.

- Howe, M.A. 1914. The marine algae of Peru. Mem. Torrey Club 15:1-185.
- Hruby, T. 1978. Impacts of large-scale aquatic biomass systems. Woods Hole Oceanographic Institution Tech. Rep. WHOI-78-31, Woods Hole, Mass. 25 pp.
- Hubbs, C.L., A.L. Kelly, and C. Limbaugh. 1970. Diversity in feeding by Brandt's cormorant near San Diego. Calif. Fish Game 56:156-165.
- Hult, G.E. 1917. Kelp. Q.J. Univ. N. Dakota 3:272-276.
- Hunt, D.E. 1977. Population dynamics of Tegula and Calliostoma in Carmel Bay, with special reference to kelp harvesting. Master's Thesis, San Francisco State University, Calif. 81 pp.
- Hurlbert, S.H. 1984. Pseudoreplication and the design of ecological field experiments. Ecol. Monogr. 54:187-211.
- Hurley, A.C. 1975. The establishment of populations of Balanus pacificus Pilsbry (Cirripedia) and their elimination by predatory Turbellaria. J. Anim. Ecol. 44:521-532.
- Isaacs, J.D. 1976. Wave climate modification and monitoring. Pages 87-90 in University of California Sea Grant College Program annual report 1975-1976. Sea Grant Publ. 57, La Jolla, Calif.
- Jackson, G.A. 1977. Nutrients and production of the giant kelp Macrocystis pyrifera off southern California. Limnol. Oceanogr. 22:979-995.
- Jackson, G.A. 1983. The physical and chemical environment of a kelp community. Pages 11-37 in W. Bascom, ed. The effects of waste disposal on kelp communities. Southern California Coastal Water Research Project, Long Beach.
- Jackson, G.A., and C.D. Winant. 1983. Effect of a kelp forest on a coastal currents. Continental Shelf Rep. 2:75-80.
- Jameson, R.A. 1983. Evidence of birth of a sea otter on land in central California. Calif. Fish Game 69:122-123.
- Jerlov, N.G. 1968. Optical oceanography. Elsevier Publ. Co., New York. 194 pp.
- Johansen, H.W., and L.F. Austin. 1970. Growth rates in the articulated coralline Calliarthron (Rhodophyta). Can. J. Bot. 48:125-182.
- Johnson, D.L. 1980. Episodic vegetation stripping, soil erosion, and landscape modification in prehistoric and recent historic time, San Miguel Island, California. Pages 103-121 in D.M. Power, ed. The California islands: proceedings of a multidisciplinary symposium. Santa Barbara Mus. Nat. Hist., Santa Barbara, Calif.
- Jones, L.G. 1971. Studies on selected small herbivorous invertebrates inhabiting Macrocystis canopies and holdfasts in southern California kelp beds. Nova Hedwigia 32:343-367.
- Jones, N.S., and J.M. Kain. 1967. Subtidal algal colonization following the removal of Echinus. Helgol. Wiss. Merresunters. 15:460-466.
- Jones, R.E. 1981. Food habits of smaller marine mammals from northern California. Proc. Calif. Acad. Sci. 44:409-433.
- Kain, J.M. 1963. Aspects of the biology of Laminaria hyperborea. II. Age, weight and length. J. Mar. Biol. Assoc. U.K. 43:129-151.
- Kain, J.M. 1975. The biology of Laminaria hyperborea. VII. Reproduction of the sporophyte. J. Mar. Biol. Assoc. U.K. 55:567-582.
- Kain, J.M. 1976. The biology of Laminaria hyperborea. IX. Growth patterns of fronds. J. Mar. Biol. Assoc. U.K. 56:603-628.
- Kain, J.M. 1979. A view of the genus Laminaria. Oceanogr. Mar. Biol. Annu. Rev. 17:101-161.

- Kain, J.M. 1982. The reproductive phenology of nine species of Rhodophyta in the subtidal region of the Isle of Man. *Brit. Phycol. J.* 17:321-331.
- Kastendiek, J. 1982. Competitor-mediated coexistence: interactions among three species of benthic macroalgae. *J. Exp. Mar. Biol. Ecol.* 62:201-210.
- Kennelly, S.J. 1983. An experimental approach to the study of factors affecting algal colonization in a sublittoral kelp forest. *J. Exp. Mar. Biol. Ecol.* 68:257-276.
- Kennelly, S.J., and A.J. Underwood. 1984. Underwater microscopic sampling of a sublittoral kelp community. *J. Exp. Mar. Biol. Ecol.* 76:67-78.
- Kenyon, K. 1969. The sea otter in the eastern Pacific Ocean. *North American Fauna* 68:1-352.
- Kimura, R.S., and M.S. Foster. In press. The effects of harvesting Macrocystis pyrifera on the algal assemblage in a giant kelp forest. *Hydrobiologia*.
- Kirkwood, P.D. 1977. Seasonal growth patterns in the growth of the giant kelp Macrocystis pyrifera. Ph.D. Thesis, California Institute of Technology, Pasadena. 144 pp.
- Kitching, J.A., T.T. Macan, and H.C. Gilson. 1934. Studies in sublittoral ecology. I. A submarine gully in Wembury Bay, South Devon. *J. Mar. Biol. Assoc. U.K.* 19:677-705.
- Kleppel, G., E. Manzanilla, B. Teter, and S. Petrich. 1982. Santa Monica Bay plankton distribution. Pages 71-84 in W. Bascom, ed. Coastal water research project: biennial report for the years 1981-1982. Southern California Coastal Water Research Project, Long Beach.
- Koehl, M.A.R., and S.A. Wainwright. 1977. Mechanical adaptations of a giant kelp. *Limnol. Oceanogr.* 22:1067-1071.
- Kuhnemann, O. 1970. Algunas consideraciones sobre los bosques de Macrocystis pyrifera. *Physis* 29:273-296.
- Kuwabara, J.S. 1982. Micronutrients and kelp cultures: evidence for cobalt and manganese deficiency in southern California deep sea water. *Science* 216:1219-1221.
- Kuwabara, J.S., and W.J. North. 1980. Culturing microscopic stages of Macrocystis pyrifera (Phaeophyta) in aquil, a chemically defined medium. *J. Phycol.* 16:546-549.
- Larson, R.J. 1980a. Competition, habitat selection and the bathymetric segregation of two rockfish (Sebastes) species. *Ecol. Monogr.* 50:221-239.
- Larson, R.J. 1980b. Territorial behavior of the black and yellow rockfish and gopher rockfish Scorpaenidae, Sebastes. *Mar. Biol. (Berl.)* 58:111-122.
- Larson, R.J. 1980c. Influence of territoriality on adult density in two rockfishes of the genus Sebastes. *Mar. Biol. (Berl.)* 58:123-132.
- Larson, R.J., and E.E. DeMartini. In press. Abundance and vertical distribution of fishes in a cobble-bottom kelp forest off San Onofre, California. *U.S. Natl. Mar. Fish. Serv. Fish. Bull.*
- Laur, D.R., and A.W. Ebeling. 1983. Predator-prey relationships in surf-perches. *Environ. Biol. Fish.* 8:217-229.
- Lawrence, J.M. 1975. On the relationships between marine plants and sea urchins (Echinodermata: Echinoidea). *Oceanogr. Mar. Biol. Annu. Rev.* 13:213-286.
- Leaman, B.M. 1976. The association between the black rockfish (Sebastes melanops Girard) and the beds of the giant kelp (Macrocystis integrifolia Bory) in Barkley Sound, British Columbia. Master's Thesis, University of British Columbia, Vancouver. 109 pp.
- Lees, D.C., and G.A. Carter. 1972. The covering response to surge, sunlight, and ultraviolet light in Lytechinus anamesus (Echinoidea). *Ecology* 53:1127-1133.

- Leighton, D.L. 1961. Observations of the effect of diet on shell coloration in the red abalone Haliotis rufescens Swainson. Veliger 4:29-32.
- Leighton, D.L. 1971. Grazing activities of benthic invertebrates in southern California kelp beds. Nova Hedwigia 32:421-453.
- Leighton, D.L., and C.F. Phleger. 1977. The purple-hinge rock scallop, a new candidate for marine aquaculture. Proc. World Maricult. Soc. 8:457-469.
- Leighton, D.L., L.G. Jones, and W.J. North. 1966. Ecological relationships between giant kelp and sea urchins in southern California. Proc. Int. Seaweed Symp. 5:141-153.
- Lissner, A.L. 1980. Some effects of turbulence on the activity of the sea urchin Centrostephanus coronatus Verrill. J. Exp. Mar. Biol. Ecol. 48:185-193.
- Lobban, C.S. 1978. The growth and death of the Macrocystis sporophyte (Phaeophyceae, Laminariales). Phycologia 17:196-212.
- LOSL (Lockheed Ocean Science Laboratories). 1983. Final report on Pendleton artificial reef. Mimeo Rep. Encinitas, Calif. n.p.
- Love, M.S. 1980. Isolation of olive rockfish, Sebastes serranoides, populations off southern California. U.S. Natl. Mar. Fish. Serv. Fish. Bull. 77:975-983.
- Love, M.S., and A.W. Ebeling. 1978. Food and habitat of three switch-feeding fishes in the kelp forests off Santa Barbara, California. U.S. Natl. Mar. Fish. Serv. Fish. Bull. 76:257-271.
- Love, M.S., and W.V. Westphal. 1981. Growth, reproduction and food habits of olive rockfish, Sebastes serranoides off central California. U.S. Natl. Mar. Fish. Serv. Fish. Bull. 79:533-546.
- Lowry, L.F., and J.S. Pearse. 1973. Abalones and sea urchins in an area inhabited by sea otters. Mar. Biol. (Berl.) 23:213-219.
- Lowry, L.F., A.J. McElroy, and J.S. Pearse. 1974. The distribution of six species of gastropod molluscs in a California kelp forest. Biol. Bull. (Woods Hole) 147:386-396.
- Lubchenko, J. 1978. Plant species diversity in a marine intertidal community: importance of herbivore food preference and algal competitive abilities. Am. Nat. 112:23-39.
- Luning, K. 1969. Standing crop and leaf area index of the sublittoral Laminaria species near Helgoland. Mar. Biol. (Berl.) 3:282-286.
- Luning, K. 1979. Growth strategies of three Laminaria species (Phaeophyceae) inhabiting different depth zones in the sublittoral region of Helgoland (North Sea). Mar. Ecol. Prog. Ser. 1:195-207.
- Luning, K. 1980. Critical levels of light and temperature regulating the gametogenesis of three Laminaria species (Phaeophyceae). J. Phycol. 16:1-15.
- Luning, K. 1981. Photobiology of seaweeds: ecophysiological aspects. Proc. Int. Seaweed Symp. 10:35-55.
- Luning, K., and M.J. Dring. 1972. Reproduction induced by blue light in female gametophytes of Laminaria saccharina. Planta (Berl.) 104:252-256.
- Luning, K., and M. Neushul. 1978. Light and temperature demands for growth and reproduction of laminarian gametophytes in southern and central California. Mar. Biol. (Berl.) 45:297-309.
- MacGinitie, G.E., and N. MacGinitie. 1968. Natural history of marine animals, 2nd ed. McGraw-Hill, New York. 523 pp.
- Manley, S.L., and W.J. North. 1984. Phosphorous and the growth of juvenile Macrocystis pyrifera (Phaeophyta) sporophytes. J. Phycol. 20:389-393.
- Mann, K.H. 1972a. Ecological energetics of the seaweed zone in a marine bay on

- the Atlantic coast of Canada. I. Zonation and biomass of seaweeds. *Mar. Biol. (Berl.)* 12:1-10.
- Mann, K.H. 1972b. Energetics of the seaweed zone in a marine bay on the Atlantic coast of Canada. II. Productivity of the seaweeds. *Mar. Biol. (Berl.)* 14:199-209.
- Mann, K.H. 1973. Seaweeds: their productivity and strategy for growth. *Science* 182:975-981.
- Mann, K.H. 1982. Ecology of coastal waters. University of California Press, Berkeley. 322 pp.
- Martin, M., M.D. Stephenson, and J.H. Martin. 1977. Copper toxicity experiments in relation to abalone deaths observed in a power plant's cooling waters. *Calif. Fish Game* 63:95-100.
- Mattison, J.E., J.D. Trent, A.L. Shanks, T.B. Akin, and J.S. Pearse. 1977. Movement and feeding activity of red sea urchins (*Strongylocentrotus franciscanus*) adjacent to a kelp forest. *Mar. Biol. (Berl.)* 39:25-30.
- McFarland, F.M. 1912. The kelps of the central California coast. Pages 194-208 plus plates in F.K. Cameron, ed. A preliminary report on the fertilizer resources of the United States. U.S. Senate, 62nd Congress, 2nd session, Document 190, Washington, D.C.
- McFarland, W.N., and J. Prescott. 1959. Standing crop, chlorophyll content and in situ metabolism of a giant kelp community in southern California. *Univ. Tex. Inst. Mar. Sci.* 6:109-132.
- McGrath, R.A., A.D. Michael, W.F. Grocki, M.S. Foster, R.J. Livingston, D. Straughan. 1980. Review and evaluation of benthic environmental studies at San Onofre Nuclear Generating Station. Taxon, Inc., Salem, Mass. 124 pp.
- McLean, J.H. 1962. Sublittoral ecology of kelp beds of the open coast area near Carmel, California. *Biol. Bull. (Woods Hole)* 122:95-114.
- McPeak, R.H., and D.A. Glantz. 1984. Harvesting California's kelp forests. *Oceanus* 27:19-26.
- Mearns, A.J. 1978. Variations in coastal physical and biological conditions, 1968-78. Pages 147-156 in W. Bascom, ed. Southern California Coastal Water Research Project Annual Report. 1978. Southern California Coastal Water Research Project, Long Beach.
- Mearns, A.J., and M. Sherwood. 1977. Distribution of neoplasms and other disease in marine fishes relative to the discharge of waste water. *Annu. N.Y. Acad. Sci.* 198:210-224.
- Meistrell, J.C., and D.E. Montagne. 1983. Waste disposal in southern California and its effects on the rocky subtidal habitat. Pages 84-102 in W. Bascom, ed. The effects of waste disposal on kelp communities. Southern California Coastal Water Research Project, Long Beach.
- Mertz, R.C. 1959. Determination of the quantity of oily substances on beaches and in nearshore waters. California State Water Pollution Control Board, Sacramento. Publ. 21. 45 pp.
- Miller, D.J., and R.N. Lea. 1972. Guide to the coastal marine fishes of California. *Calif. Dep. Fish Game Fish Bull.* 157:1-249.
- Miller, D.J., and J.J. Geibel. 1973. Summary of blue rockfish and lingcod life histories; a reef ecology study; and giant kelp, *Macrocystis pyrifera*, experiments in Monterey Bay, California. *Calif. Dep. Fish Game Fish Bull.* 158:1-137.
- Miller, R.J., and A.G. Colodey. 1983. Widespread mass mortalities of the green sea urchin in Nova Scotia, Canada. *Mar. Biol. (Berl.)* 73:263-267.
- Mitchell, C.T., and J.R. Hunter. 1970. Fishes associated with drifting kelp, *Macrocystis pyrifera*, off the coast of southern California and northern Baja California. *Calif. Fish Game* 56:288-297.

- Moore, L.B. 1943. Observations on the growth of Macrocystis in New Zealand. Trans. R. Soc. N.Z. 72:333-341.
- Morejohn, G.V. 1977. Marine mammals. Pages 1-74 in A summary of knowledge of the central and northern California coastal zone and offshore areas. Vol. II, Book 2 of 3: Biological conditions. U.S. Dep. Commer. PB-274-213. National Technical Information Service, Springfield, Va.
- Moreno, C.A., and J.P. Sutherland. 1982. Physical and biological processes in a Macrocystis pyrifera community near Valdivia, Chile. Oecologia 55:1-6.
- Moreno, C.A., and H.F. Jara. 1984. Ecological studies on fish fauna associated with Macrocystis pyrifera belts in the south of Fuegian Islands, Chile. Mar. Ecol. Prog. Ser. 15:99-107.
- Morris, R.H., D.P. Abbott, and E.C. Haderlie. 1980. Intertidal invertebrates of California. Stanford University Press, Stanford, Calif. 690 pp.
- Morse, D.E., N. Hooker, H. Duncan, and L. Jensen. 1979.  $\delta$  - aminobutyric acid, a neurotransmitter, induces planktonic abalone larvae to settle and begin metamorphosis. Science 204:407-410.
- Moser, M., and M. Love. 1978. Common parasites of California marine fish. Calif. Dep. Fish Game, Marine Resources Region, Long Beach, Calif. 11 pp.
- Moss, B.L. 1982. The control of epiphytes by Halidrys seleguosa (L.) Lyngb (Phaeophyta, Cystoseiraceae). Phycologia 21:185-191.
- Murdoch, W.W., B.J. Mechals, and R.C. Fay. 1980. Predictions of the effects of San Onofre Nuclear Generating Station and recommendations. Part I: Recommendations, predictions and rationale. MRC Document 80-04II. Marine Review Committee, Encinitas, Calif. 71 pp.
- Murison, L.D., D.J. Murie, K.R. Moria, and J. Silva-Curie. In press. Foraging of the gray whale (Eschrichtius robustus Lilljeborg) along the west coast of Vancouver Island, British Columbia in M.L. Jones, S. Swartz, and S. Leatherwood, eds. The gray whale. Academic Press, New York.
- Murray, S.N., M.M. Littler, and I.A. Abbott. 1980. Biogeography of the California marine algae with emphasis on the southern California islands. Pages 325-339 in D.M. Power, ed. The California islands: proceedings of a multidisciplinary symposium. Santa Barbara Mus. Nat. Hist., Santa Barbara, Calif.
- Nelson, B.V., and R.R. Vance. 1979. Diel foraging patterns of the sea urchin Centrostephanus coronatus as a predator avoidance strategy. Mar. Biol. (Berl.) 51:251-258.
- Neushul, M. 1963. Studies on the giant kelp, Macrocystis. II. Reproduction. Am. J. Bot. 50:354-359.
- Neushul, M. 1965. SCUBA diving studies of the vertical distribution of benthic marine plants. Pages 161-176 in Proceedings of the fifth marine biology symposium. Acta Universitatis, Goteburg.
- Neushul, M. 1967. Studies of subtidal marine vegetation in western Washington. Ecology 48:83-94.
- Neushul, M. 1971a. The species of Macrocystis with particular reference to those of North and South America. Nova Hedwigia 32:211-228.
- Neushul, M. 1971b. Submarine illumination in Macrocystis beds. Nova Hedwigia 32:241-254.
- Neushul, M. 1972. Functional interpretation of benthic marine algal morphology. Pages 47-74 in T.A. Abbott and M. Kurogi, eds. Contributions to the systematics of benthic marine algae of the North Pacific. Japanese Society of Phycology, Kobe.
- Neushul, M. 1981. Historical review of kelp beds in the Southern California Bight. Southern California Edison Company Research Rep. Ser. 81-RD-98, Final Rep. Neushul Mariculture, Inc., Goleta, Calif. 74 pp.



- Neushul, M., and F.T. Haxo. 1963. Studies on the giant kelp, Macrocystis. I. Growth of young plants. Am. J. Bot. 50:349-353.
- Neushul, M., and B.W. Harger. In press. Studies of biomass yield from a near-shore macroalgal test farm. J. Sol. Energy Eng.
- Neushul, M., W.D. Clarke, and D.W. Brown. 1967. Subtidal plant and animal communities of the southern California islands. Pages 37-55 in R. Philbrick, ed. Proceedings of the symposium on the biology of the California Islands. Santa Barbara Botanic Garden, Santa Barbara, Calif.
- Neushul, M., M.S. Foster, D.A. Coon, J.W. Woessner, and B.W. Harger. 1976. An in situ study of recruitment, growth and survival of subtidal marine algae: techniques and preliminary results. J. Phycol. 12:397-408.
- Newell, G.E., and R.C. Newell. 1963. Marine plankton: a practical guide. Hutchinson Educational Ltd., London. 221 pp.
- North, W.J. 1957. Kelp investigations program annual report for the period 1 July 1956-30 June 1957. University of California Institute of Marine Resources, La Jolla. 60 pp.
- North, W.J. 1963. Kelp habitat improvement project: annual report 1962-1963. W.M. Keck Laboratory of Environmental Health Engineering. California Institute of Technology, Pasadena. 123 pp.
- North, W.J. 1966. Kelp habitat improvement project: annual report 1965-1966. W.M. Keck Laboratory of Environmental Health Engineering. California Institute of Technology, Pasadena. 95 pp.
- North, W.J. 1967. Kelp habitat improvement project: annual report 1966-1967. W.M. Keck Laboratory of Environmental Health Engineering. California Institute of Technology, Pasadena. 105 pp.
- North, W.J. 1968. Kelp habitat improvement project: annual report 1967-1968. W.M. Keck Laboratory of Environmental Health Engineering. California Institute of Technology, Pasadena. 123 pp.
- North, W.J. 1969. Kelp habitat improvement project: annual report 1968-1969. W.M. Keck Laboratory of Environmental Health Engineering. California Institute of Technology, Pasadena. 142 pp.
- North, W.J., ed. 1971a. The biology of giant kelp beds (Macrocystis) in California. Nova Hedwigia 32:1-600.
- North, W.J. 1971b. Introduction and background. The biology of giant kelp beds (Macrocystis) in California Nova Hedwigia 32:1-97.
- North, W.J. 1971c. Growth of individual fronds of the mature giant kelp Macrocystis. Nova Hedwigia 32:123-168.
- North, W.J. 1972a. Kelp habitat improvement project: annual report 1971-1972. W.M. Keck Laboratory of Environmental Health Engineering. California Institute of Technology, Pasadena. 200 pp.
- North, W.J. 1972b. Observations on populations of Macrocystis. Pages 75-92 in I.A. Abbott and M. Kurogi, eds. Contributions to the systematics of benthic marine algae of the North Pacific. Japanese Society of Phycology, Kobe.
- North, W.J. 1973. Kelp habitat improvement project: annual report 1972-1973. W.M. Keck Laboratory of Environmental Health Engineering. California Institute of Technology, Pasadena. 181 pp.
- North, W.J. 1974. Kelp habitat improvement project: annual report 1973-1974. W.M. Keck Laboratory of Environmental Health Engineering. California Institute of Technology, Pasadena. 137 pp.
- North, W.J. 1976a. Underwater California. University of California Press, Berkeley, Calif. 276 pp.
- North, W.J. 1976b. Aquacultural techniques for creating and restoring beds of giant kelp, Macrocystis spp. J. Fish. Res. Board Can. 33:1015-1023.

- North, W.J. 1977. Possibilities of biomass from the ocean. The marine farm project. Pages 347-361 in A. Mitsui, S. Miyachi, A. San Piero, and S. Tamura, eds. Biological solar energy conversion. Academic Press, New York.
- North, W.J. 1980. Trace metals in giant kelp, Macrocystis. Am. J. Bot. 67:1097-1101.
- North, W.J. 1982. General characteristics of brown macroalgae: Macrocystis. Pages 69-74 in O.R. Zaborsky, ed. CRC handbook of biosolar resources. CRC Press, Boca Raton, Fla.
- North, W. 1983a. The sea urchin problem. Pages 147-162 in W. Bascom, ed. The effects of waste disposal on kelp communities. Southern California Coastal Water Research Project, Long Beach.
- North, W. 1983b. Separating the effects of temperature and nutrients. Pages 243-255 in W. Bascom, ed. The effects of waste disposal on kelp communities. Southern California Coastal Water Research Project, Long Beach.
- North, W.J., and C.L. Hubbs. 1968. Utilization of kelp-bed resources in southern California. Calif. Dep. Fish Game Fish Bull. 139:1-264.
- North, W.J., and M. Neushul. 1968. A note on the possibility of large-scale cultivation of Macrocystis. Pages 17-24 in W.J. North and C.L. Hubbs, eds. Utilization of kelp-bed resources in southern California. Calif. Dep. Fish Game Fish Bull. 139.
- North, W.J., and J.S. Pearse. 1970. Sea urchin population explosion in southern California coastal waters. Science 167:209.
- North, W.J., and M.B. Schaefer. 1964. An investigation on the effects of discharged wastes on kelp. Calif. Water Quality Control Board Publ. 26. 124 pp.
- North, W.J., M. Neushul, and K.A. Clendenning. 1964. Successive biological changes observed in a marine cove exposed to a large spillage of mineral oil. Pages 335-354 in Proceedings of the symposium on pollution of marine organisms. Prod. Petrol., Monaco.
- North, W., V. Gerard, and J. Kuwabara. 1982. Farming Macrocystis at coastal and oceanic sites. Pages 247-264 in L. Srivastava, ed. Synthetic and degradative processes in marine macrophytes. Walter de Gruyter, Berlin.
- Norton, T.A. 1977. Experiments on the factors influencing the geographical distribution of Saccorhiza polyschides and Saccorhiza dermatodea. New Phytol. 78:625-635.
- Norton, T.A. 1978. The factors influencing the distribution of Saccorhiza polyschides in the region of Lough Ine. J. Mar. Biol. Assoc. U.K. 58:527-536.
- Norton, T.A. 1981. Sargassum muticum on the Pacific coast of North America. Proc. Int. Seaweed Symp. 6:449-456.
- O'Connell, C.P. 1953. The life history of the cabezon. Calif. Dep. Fish Game Fish Bull. 93:1-76.
- Ojeda, F.P., and B. Santelices. 1984. Invertebrate communities in holdfasts of the kelp Macrocystis pyrifera from southern Chile. Mar. Ecol. Prog. Ser. 16:65-73.
- Oliphant, M.S. 1979. California marine fish landings for 1976. Calif. Dep. Fish Game Fish Bull. 170:1-56.
- Oliver, J.S., P.N. Slattery, M.A. Silberstein, and E.F. O'Conner. 1983. A comparison of gray whale, Eschrichtius robustus, feeding in the Bering Sea and Baja California. U.S. Natl. Mar. Fish. Serv. Fish. Bull. 81:513-522.
- Ostarello, G.L. 1973. Natural history of the hydrocoral Allopora californica Verrill (1866). Biol. Bull. (Woods Hole) 145:548-564.
- Ostarello, G.L. 1976. Larval dispersion in the subtidal hydrocoral Allopora californica Verrill (1866). Pages 331-337 in G.O. Mackie, ed. Coelenterate

- ecology and behavior. Plenum Press, New York.
- Ostfeld, R.S. 1982. Foraging strategies and prey switching in the California sea otter. *Oecologia* 53:170-178.
- Page, G.W., P.R. LeValley, R.M. Stewart, and D.G. Ainley. 1977. Marine and shore birds. Pages 1-212 in *A summary of knowledge of the central and northern California coastal and offshore areas*. Vol. II, Book 3 of 3: Biological conditions. U.S. Dep. Commer. PB-274-214. National Technical Information Service, Springfield, Va.
- Paine, R.T. 1966. Food web complexity and species diversity. *Am. Nat.* 100:65-75.
- Paine, R.T. 1974. Intertidal community structure: experimental studies on the relationship between a dominant competitor and its principal predator. *Oecologia* 15:93-120.
- Paine, R.T. 1976. Biological observations on a subtidal *Mytilus californianus* bed. *Veliger* 19:125-130.
- Paine, R.T. 1979. Disaster, catastrophe and local persistence of the sea palm *Postelsia palmaeformis*. *Science* 205:685-687.
- Paine, R.T., and R.L. Vadas. 1969. The effects of grazing by sea urchins, *Strongylocentrotus* spp., on benthic algal populations. *Limnol. Oceanogr.* 14:710-719.
- Parker, B.C. 1963. Translocation in the giant kelp *Macrocystis*. *Science* 4:27-42.
- Parker, B.C. 1971. Studies of translocation in *Macrocystis*. *Nova Hedwigia* 32:191-195.
- Parker, B.C., and J. Bleck. 1966. A contribution to the ecology of *Pelagophycus*. *Ann. Mo. Bot. Gard.* 53:1-16.
- Parsons, T.R., M. Takahashi, and B. Hargrave. 1977. *Biological oceanographic processes*, 2nd ed. Pergamon Press, New York. 332 pp.
- Pearse, J.S., and A.H. Hines. 1976. Kelp forest ecology of the central California coast. Pages 56-58 in *University of California. Sea Grant College Program annual report 1975-1976*. Sea Grant Publ. 57, La Jolla.
- Pearse, J.S., and A.H. Hines. 1979. Expansion of a central California kelp forest following the mass mortality of sea urchins. *Mar. Biol. (Berl.)* 51:83-91.
- Pearse, J.S., and L.F. Lowry. 1974. An annotated species list of the benthic algae and invertebrates in the kelp forest community at Point Cabrillo, Pacific Grove, California. Coastal Marine Laboratory, University of California, Santa Cruz. Tech. Rep. 1. 73 pp.
- Pearse, J.S., D.P. Costa, M.B. Yellin, and C.R. Agegian. 1977. Localized mass mortality of red sea urchin, *Strongylocentrotus franciscanus* near Santa Cruz, California. U.S. Natl. Mar. Fish. Serv. Fish. Bull. 75:645-648.
- Pequegnat, W.E. 1964. The epifauna of a California siltstone reef. *Ecology* 45:272-283.
- Phinney, H.K. 1977. The macrophytic marine algae of Oregon. Pages 93-115 in R.W. Krauss, ed. *The marine plant biomass of the Pacific Northwest coast*. Oregon State University Press, Corvallis.
- Platt, T. 1971. The annual production by phytoplankton in St. Margaret's Bay, Nova Scotia. *J. Cons. Cons. Int. Explor. Mer* 33:324-333.
- Pleschner, D.B. 1984. Fish of the month: sea otters. *Pac. Fish. (July)*:39-47.
- Poole, M.M. In press. Migration corridors of gray whales (*Eschrichtius robustus*) along the central California coast, 1980-1982 in M.L. Jones, S. Swartz, and S. Leatherwood, eds. *The gray whale*. Academic Press, New York.
- Prince, E.D. 1975. Pinnixid crabs in the diet of young-of-the-year copper rockfish (*Sebastes courinus*). *Trans. Am. Fish. Soc.* 104:539-540.

- Pringle, J.D., G.J. Sharp, and J.F. Caddy. 1980. An update on the relationship between commercial lobstering and urchin and macroalgal densities. Pages 237-251 in J.D. Pringle, G.J. Sharp, and J.F. Caddy, eds. Proceedings of the workshop on the relationship between sea urchin grazing and commercial plant/animal harvesting. Can. Tech. Rep. Fish. Aquat. Sci. Vol. 954.
- Quadir, A., P.J. Harrison, and R.E. DeWreede. 1979. The effects of emergence and submergence on the photosynthesis and respiration of marine macrophytes. *Phycologia* 18:83-88.
- Quast, J.C. 1968. Observations on the food and biology of the kelp bass, Paralbrax clathratus, with notes on its sportfishery at San Diego, California. Calif. Fish Game Fish Bull. 139:81-108.
- Quast, J.C. 1971a. Fish fauna of the rocky inshore zone. *Nova Hedwigia* 32:481-507.
- Quast, J.C. 1971b. Estimates of the populations and the standing crop of kelp bed fishes. *Nova Hedwigia* 32:509-540.
- Quast, J.C. 1971c. Some physical aspects of the inshore environment, particularly as it affects kelp bed fishes. *Nova Hedwigia* 32:229-240.
- Quast, J.C. 1971d. Observations on the food of the kelp bed fishes. *Nova Hedwigia* 32:541-579.
- Ramus, J. In press. Light in M.M. Littler and D.S. Littler, eds. Handbook of phycological methods: ecological methods for macroalgae. Cambridge University Press, Cambridge, England.
- Reed, D.C., and M.S. Foster. 1984. The effects of canopy shading on algal recruitment and growth in a giant kelp forest. *Ecology* 65:937-948.
- Rice, D.W. 1968. Stomach contents and feeding behavior of killer whales in the eastern North Pacific. *Nor. Hvalfangstidende* 571:35-38.
- Rice, D.W., and A.A. Wolman. 1971. The life history and ecology of the gray whale (Eschrichtius robustus). *Am. Soc. Mammal. Spec. Publ.* 3. 131 pp.
- Ricketts, E.F., J. Calvin, and J.W. Hedgpeth. 1968. Between Pacific tides, 4th ed. Stanford University Press, Stanford, Calif. 614 pp.
- Riedman, M.L., A.H. Hines, and J.S. Pearse. 1981. Spatial segregation of four species of turban snails (Gastropoda: legula) in central California. *Veliger* 24:97-102.
- Roberts, D.A. 1979. Food habits as an ecological partitioning mechanism in the nearshore rockfishes (Sebastes) of Carmel Bay, California. Master's Thesis, San Francisco State University, Calif. 77 pp.
- Rosenthal, R.J. 1971. Trophic interaction between the sea star Pisaster giganteus and the gastropods Kelletia kelletii. *U.S. Natl. Mar. Fish. Serv. Fish. Bull.* 69:669-679.
- Rosenthal, R.J., and J.R. Chess. 1972. A predator-prey relationship between the leather star (Dermasterias imbricata) and the purple urchin (Strongylocentrotus purpuratus). *U.S. Natl. Mar. Fish. Serv. Fish. Bull.* 70:205-216.
- Rosenthal, R.J., W.E. Clarke, and P.K. Dayton. 1974. Ecology and natural history of a stand of giant kelp, Macrocystis pyrifera, off Del Mar, California. *U.S. Natl. Mar. Fish. Serv. Fish. Bull.* 72:670-684.
- Ryther, J.H. 1969. Photosynthesis and fish production in the sea. *Science* 166:72-76.
- Saito, Y. 1972. On the effects of environmental factors on morphological characteristics of Undaria pinnatifida and the breeding of hybrids in the genus Undaria. Pages 117-132, pl. 1 in I.A. Abbott and M. Kurogi, eds. Contributions to the systematics of benthic marine algae of the North Pacific. Japanese Society of Phycology, Kobe.
- Sanbonsuga, Y., and M. Neushul. 1980. Hybridization and genetics of brown algae. Pages 69-83 in E. Gantt, ed.

- Handbook of phycological methods: developmental and cytological methods. Cambridge University Press, Cambridge, England.
- Sandegren, F.E., E.W. Chu, and J.E. Vandervere. 1973. Maternal behavior in the California sea otter. *J. Mammal.* 54:668-679.
- Santelices, B., and F.P. Ojeda. 1984a. Effects of canopy removal on the under-story algal community structure of coastal forests of *Macrocystis pyrifera* from southern South America. *Mar. Ecol. Prog. Ser.* 14:165-173.
- Santelices, B., and F.P. Ojeda. 1984b. Population dynamics of coastal forests of *Macrocystis pyrifera* in Puerto Toro, Isla Navarino, Southern Chile. *Mar. Ecol. Prog. Ser.* 14:175-183.
- Santelices, B., J. Correa, and M. Avila. 1983. Benthic algal spores surviving digestion by sea urchins. *J. Exp. Mar. Biol. Ecol.* 70:263-269.
- Scagel, R.F. 1967. Guide to common seaweeds of British Columbia. British Columbia Provincial Museum. Dep. of Recreation and Conservation Handbook 27. 330 pp.
- SCE (Southern California Edison Company). 1978. Annual operating report, San Onofre Nuclear Generating Station, Vol. IV. Biological, sedimentological, and oceanographic data analyses, 1978. SCE Rep. 79-RD-54. Rosemead, Calif. n.p.
- SCE (Southern California Edison Company). 1979. Annual operating report, San Onofre Nuclear Generating Station, Vol. V. Biological and oceanographic data analyses, 1979. SCE Rep. 80-RD-100, Chap. 5. Rosemead, Calif. n.p.
- SCE (Southern California Edison Company). 1982. Annual report, marine environmental analysis and interpretation, San Onofre Nuclear Generating Station. SCE Rep. 82-RD-51, Chap. 5. Rosemead, Calif. n.p.
- Scammon, C.M. 1874. The marine mammals of the northwestern coast of North America. J.H. Carmany Co., San Francisco. 319 pp.
- Schiel, D.R. 1981. A demographic and experimental evaluation of plant and herbivore interaction in subtidal algal stands. Ph.D. Thesis, University of Auckland. 166 pp.
- Schiel, D.R. 1982. Selective feeding by the echinoid *Evechinus chloroticus*, and the removal of plants from subtidal algal stands in northern New Zealand. *Oecologia* 54:379-388.
- Schiel, D.R. In press a. A short-term demographic study of *Cystoseira osmundacea* (Fucales: Cystoseiraceae) in central California. *J. Phycol.*
- Schiel, D.R. In press b. Recruitment, growth and reproduction of two species of marine algae (Fucales: Sargassaceae) at different densities. *J. Ecol.*
- Schiel, D.R., and J.H. Choat. 1980. Effects of density on monospecific stands of marine algae. *Nature (Lond.)* 285:324-326.
- Schiel, D.R., and M.S. Foster. In preparation The effects of severe swells on a giant kelp community in Carmel Bay.
- Schmitt, R.J. 1982. Consequences of dissimilar defenses against predation in a subtidal marine community. *Ecology* 63:1588-1601.
- Schmitt, R.J., C.W. Osenberg, and M.G. Bercovitch. 1983. Mechanisms and consequences of shell fouling in the kelp snail, *Norrisia norrisi* (Sowerby) (Trochidae): indirect effects of octopus drilling. *J. Exp. Mar. Biol. Ecol.* 69:267-281.
- Schonbeck, M., and T.A. Norton. 1978. Factors controlling the upper limits of fucoid algae on the shore. *J. Exp. Mar. Biol. Ecol.* 31:303-313.
- Schonbeck, M., and T.A. Norton. 1980. Factors controlling the lower limits of fucoid algae on the shore. *J. Exp. Mar. Biol. Ecol.* 43:131-150.
- Schroeter, S.C., J. Dixon, and J. Kastendiek. 1983. Effects of starfish *Patiria miniata* on the distribution of the sea urchin *Lytechinus anamesus* in a

- southern California kelp forest. *Oecologia* 56:141-147.
- Scotten, H.L. 1971. Microbiological aspects of the kelp bed environment. *Nova Hedwigia* 32:315-318.
- Sebens, K.P. 1983. Population dynamics and habitat suitability of the intertidal sea anemones Anthopleura elegantissima and A. xanthogrammica. *Ecol. Monogr.* 53:405-433.
- Setchell, W.A. 1932. Macrocystis and its holdfasts. *Univ. Calif. Publ. Bot.* 16:445-492, pls. 33-48.
- Seymour, R.J. 1983. Extreme waves in California during winter 1983. *Calif. Dep. of Boating and Waterways.* n.p.
- Shepherd, S.A., and H.B.S. Womersley. 1970. The sublittoral ecology of West Island, South Australia. I. Environmental features and the algal ecology. *Trans. R. Soc. S. Aust.* 94:105-137.
- Shepherd, S.A., and H.B.S. Womersley. 1971. Pearson Island expedition 1969. VII. The subtidal ecology of benthic algae. *Trans. R. Soc. S. Aust.* 95:155-167.
- Shimek, S.J. 1977. The underwater foraging habits of the sea otter, Enhydra lutris. *Calif. Fish Game* 63:120-122.
- Simberloff, D. 1983. Competition theory, hypothesis testing, and other community ecology buzzwords. *Am. Nat.* 122:626-635.
- Simenstad, C.A., J.A. Estes, and K.W. Kenyon. 1978. Aleuts, sea otters and alternate stable-state communities. *Science* 200:403-411.
- Singer, M.M. 1982. Food habit and activity patterns of juvenile rockfishes (Sebastes) in a central California kelp forest. Master's Thesis, San Jose State University, Calif. 75 pp.
- Siniff, D.B., T.D. Williams, A.M. Johnson, and D.L. Garshelis. 1982. Experiments on the response of sea otters Enhydra lutris to oil contamination. *Biol. Conserv.* 23:261-272.
- Smith, B.M. 1979. The effects of copper on gametophytes of Macrocystis pyrifera. Master's Thesis, California State University, Hayward. 101 pp.
- Smith R.I., and J.T. Carlton, eds. 1975. *Light's manual: intertidal invertebrates of the central California coast.* University of California Press, Berkeley. 716 pp.
- Spies, R.B., and P.H. Davis. 1979. The infaunal benthos of a natural oil seep in the Santa Barbara Channel. *Mar. Biol.* 50:227-237.
- Steinbeck, J. 1962. *The log from the Sea of Cortez.* The Viking Press, New York. 282 pp.
- Steinberg, P.D. 1984. Algal chemical defense against herbivores: allocation of phenolic compounds in the kelp Alaria marginata. *Science* 223:405-407.
- Stephenson, M.D. 1977. Sea otter predation on Pismo clams in Monterey Bay. *Calif. Fish Game* 63:117-120.
- Strong, D.R., Jr., D. Simberloff, L.G. Abele, and A.B. Thistle, eds. 1984. *Ecological communities: conceptual issues and the evidence.* Princeton University Press, Princeton, N.J. 613 pp.
- Sverdrup, H.U., M.J. Jenkinson, and R.H. Fleming. 1942. *The oceans: their physics, chemistry and general biology.* Prentice-Hall, Inc., Englewood Cliffs, N.J.
- Tegner, M.J. 1980. Multispecies considerations of resource management in southern California kelp beds. Pages 125-143 in J.D. Pringle, G.J. Sharp, and J.F. Caddy, eds. *Proceedings of the workshop on the relationship between sea urchin grazing and commercial plant/animal harvesting.* Can. Tech. Rep. Fish. Aquat. Sci. 954.
- Tegner, M.J., and P.K. Dayton. 1981. Population structure, recruitment and mortality of two sea urchins (Strongylocentrotus franciscanus and S. purpuratus) in a kelp forest. *Mar. Ecol. Prog. Ser.* 5:255-268.

- Tegner, M.J., and L.A. Levin. 1982. Do sea urchins and abalone compete in California kelp forest communities? Pages 265-271 in J.M. Lawrence, ed. International Echinoderm Conference, Tampa Bay. A.A. Balkema, Rotterdam.
- Tegner, M.J., and L.A. Levin. 1983. Spiny lobsters and sea urchins: analysis of a predator-prey interaction. *J. Exp. Mar. Biol. Ecol.* 73:125-150.
- Thompson, W.C. 1959. Attachment of the giant kelp, *Macrocystis pyrifera*, in fine sediments and its biological and geological significance. Page 586 in Proceedings of the international oceanographic congress. Am. Assoc. Adv. Sci. Publ., Washington, D.C.
- Towle, D.W., and J.S. Pearse. 1973. Production of the giant kelp, *Macrocystis*, estimated by *in situ* incorporation of <sup>14</sup>C in polyethylene bags. *Limnol. Oceanogr.* 18:155-159.
- Trotter, D.B., and J.M. Webster. 1984. Feeding preferences and seasonality of free-living marine nematodes inhabiting the kelp *Macrocystis integrifolia*. *Mar. Ecol. Prog. Ser.* 14:151-157.
- Tseng, C.K., and B.M. Sweeney. 1946. Physiological studies of *Gelidium cartilagineum*. I. Photosynthesis with special references to the carbon dioxide factor. *Am. J. Bot.* 33:706-715.
- Turner, C.H., E. Ebert, and R. Given. 1968. The marine environment offshore from Point Loma, San Diego County. Calif. Dep. Fish Game Fish Bull. 140:1-85.
- Turner, C.H., E.E. Ebert, and R.R. Given. 1969. Made-made reef ecology. Calif. Dep. Fish Game Fish Bull. 146:1-221.
- Underwood, A.J. 1979. The ecology of intertidal gastropods. *Adv. Mar. Biol.* 16:111-210.
- Underwood, A.J. 1981. Techniques of analysis of variance in experimental marine biology and ecology. *Oceanogr. Mar. Biol. Annu. Rev.* 19:513-605.
- Underwood, A.J., and P. Jernakoff. 1981. Effects of interactions between algae and grazing gastropods on the structure of a low-shore intertidal algal community. *Oecologia* 48:221-233.
- Underwood, A.J., and P. Jernakoff. 1984. The effects of tidal height, wave-exposure, seasonality and rock-pools on grazing and the distribution of intertidal macroalgae in New South Wales. *J. Exp. Mar. Biol. Ecol.* 75:71-96.
- Underwood, A.J., and E.J. Denley. 1984. Paradigms, explanations, and generalizations in models for the structure of intertidal communities on rocky shores. Pages 151-180 in D.R. Strong, Jr., D. Simberloff, L.G. Abele, and A.B. Thistle, eds. Ecological communities: conceptual issues and the evidence. Princeton University Press, Princeton, N.J.
- Underwood, A.J., E.J. Denley, and M.J. Moran. 1983. Experimental analyses of the structure and dynamics of mid-shore rocky intertidal communities in New South Wales. *Oecologia* 56:202-219.
- Vadas, R.L. 1972. Ecological implications of culture studies on *Nereocystis leutkeana*. *J. Phycol.* 8:196-203.
- Vadas, R.L. 1977. Preferential feeding: an optimization strategy in sea urchins. *Ecol. Monogr.* 47:337-371.
- Van Blaricom, G.R. In press. Relationships of sea otters to living marine resources in California: A new perspective. In Proceedings of the ocean studies symposium. California Coastal Commission, Sacramento.
- Van Blaricom, G.R., and R.J. Jameson. 1982. Lumber spill in central California waters: implications for oil spills and sea otters. *Science* 215:1503-1505.
- Van den Hoek, C. 1982. The distribution of benthic marine algae in relation to the temperature regulation of their life histories. *Biol. J. Linn. Soc.* 18:81-144.

- Van Dykhuizen, G. 1983. Activity patterns and feeding chronology of the kelp rockfish, Sebastes atrovirens in a central California kelp forest. Master's Thesis, San Jose State University, Calif. 63 pp.
- Van Veldhuizen, H.D., and D.W. Phillips. 1978. Prey capture by Pisaster brevispinus (Asteroidea: Echinodermata) on soft substrate. *Mar. Biol. (Berl.)* 48:89-97.
- Van Wagenan, R.F., M.S. Foster, and F. Burns. 1981. Sea otter predation on birds near Monterey, California. *J. Mammal.* 62:433-434.
- Vance, R.R. 1979. Effects of grazing by the sea urchin, Centrostephanus coronatus, on prey community composition. *Ecology* 60:537-546.
- Velimirov, B., and C.L. Griffiths. 1979. Wave-induced kelp movement and its importance for community structure. *Bot. Mar.* 22:169-172.
- Velimirov, G., J.G. Field, C.L. Griffiths, and P. Zoutendyk. 1977. The ecology of the kelp bed communities in the Benguela upwelling system. Analysis of biomass and spatial distribution. *Helgol. Wiss. Meeresunters.* 30:495-518.
- Watanabe, J.M. 1983. Anti-predator defenses of three kelp forest gastropods: Contrasting adaptations of closely-related prey species. *J. Exp. Mar. Biol. Ecol.* 71:257-270.
- Watanabe, J.M. 1984a. The influence of recruitment, competition, and benthic predation on spatial distributions of three species of kelp forest gastropods (Trochidae: Tegula). *Ecology* 65:920-936.
- Watanabe, J.M. 1984b. Food preference, food quality and diets of three herbivorous gastropods (Trochidae: Tegula) in a temperate kelp forest habitat. *Oecologia* 62:47-52.
- Weaver, A.M. 1977. Aspects of the effects of particulate matter on the ecology of a kelp forest (Macrocystis pyrifera (L.) C.A. Agardh) near a small domestic sewer outfall. Ph.D. Thesis, Stanford University, Stanford, Calif. 174 pp.
- Wellington, G.M., and S. Anderson. 1978. Surface feeding by a juvenile gray whale, Eschrichtius robustus. *U.S. Natl. Mar. Fish. Serv. Fish. Bull.* 76:290-293.
- Wells, R. 1983. Disturbance mediated competition between Macrocystis pyrifera and articulated coralline algae. Pages 181-198 in W. Bascom, ed. The effects of waste disposal on kelp communities. Southern California Coastal Water Research Project, Long Beach.
- Wheeler, W.N. 1978. Ecophysiological studies on the giant kelp Macrocystis. Ph.D. Thesis, University of California, Santa Barbara. 179 pp.
- Wheeler, W.N. 1980a. Pigment content and photosynthetic rate of the fronds Macrocystis pyrifera. *Mar. Biol. (Berl.)* 56:97-102.
- Wheeler, W.N. 1980b. Effect of boundary layer transport on the fixation of carbon by the giant kelp Macrocystis prifera. *Mar. Biol. (Berl.)* 56:103-110.
- Wheeler, W.N. 1982. Nitrogen nutrition of Macrocystis. Pages 121-137 in L.M. Srivastava, ed. Synthetic and degradative processes in marine macrophytes. Walter de Gruyter, Berlin.
- Wheeler, W.N., and M. Neushul. 1981. The aquatic environment. Pages 229-247 in O.L. Lange, P.S. Nobel, C.B. Osmond, and H. Ziegler, eds. Encyclopedia of plant physiology, new series, volume 12A: physiological plant ecology I. Springer-Verlag, Berlin.
- Wheeler, P.A., and W.J. North. 1981. Nitrogen supply, tissue composition and frond growth rates for Macrocystis pyrifera. *Mar. Biol. (Berl.)* 64:59-69.
- Wiens, J.A. 1984. On understanding a non-equilibrium world: myth and reality in community patterns and processes. Pages 439-457 in D.R. Strong, Jr., D. Simberloff, L.G. Abele, and A.B.



- Thistle, eds. Ecological communities: conceptual issues and the evidence. Princeton University Press, Princeton, N.J.
- Wild, P., and J. Ames. 1974. A report on the sea otter Enhydra lutris (L.) in California. Calif. Dep. Fish Game Mar. Res. Tech. Rep. 20. 94 pp.
- Wiley, J.W. 1973. Life history of the western North American goby, Corphopterus nicholsii (Bean). San Diego Soc. Nat. Hist. Trans. 17:187-208.
- Wilson, K. 1982. The kelp forests of Palos Verdes Peninsula 1982. Pages 67-70 in W. Bascom, ed. Southern California Coastal Water Research Project Biennial Rep. 1981-1982. Southern California Coastal Water Research Project, Long Beach.
- Wilson, K., and H. Togstad. 1983. Storm caused changes in the Palos Verdes kelp forest. Pages 301-307 in W. Bascom, ed. The effects of waste disposal on kelp communities. Southern California Coastal Water Research Project, Long Beach.
- Wilson, K., and R. McPeak. 1983. Kelp restoration. Pages 199-216 in W. Bascom, ed. The effects of waste disposal on kelp communities. Southern California Coastal Water Research Project, Long Beach.
- Wing, B.L., and K.A. Clendenning. 1971. Kelp surfaces an associated invertebrates. Nova Hedwigia 32:319-341.
- Wise, D.L., R.L. Wentworth, and R.G. Kispert. 1977. Fuel gas production from selected biomass via anaerobic fermentation. Pages 411-426 in A. Mitsui, S. Miyachi, A. San Piero, and S. Tamura, eds. Biological solar energy processes. Academic Press, New York.
- Womersley, H.B.S. 1954. The species of Macrocystis with special reference to those on southern Australian coasts. Univ. Calif. Publ. Bot. 27:109-132.
- Woodhouse, C.D., R.K. Cowen, and L.R. Wilcoxon. 1977. A summary of knowledge of the sea otter Enhydra lutris, L., in California, and an appraisal of the completeness of biological understanding of the species. Rep. MMC-76/02. National Technical Information Service, Springfield, Va. 71 pp.
- Woollacott, R.M., and W.J. North. 1971. Bryozoans of California and northern Mexico kelp beds. Nova Hedwigia 32:455-479.
- Yaninek, J.S. 1980. Beach wrack; phenology of an imported resource and utilization by macroinvertebrates of sandy beaches. Master's Thesis, University of California, Berkeley. 159 pp.
- Yellin, M.B., C.R. Agegian, and J.S. Pearse. 1977. Ecological benchmarks in the Santa Cruz County kelp forests before the re-establishment of sea otters. Final Rep. to Marine Mammal Commission, PB 272813. National Technical Information Service, Springfield, Va. n.p.
- Young, P.H. 1963. The kelp bass (Paralabrax clathratus) and its fishery, 1947-1958. Calif. Dep. Fish Game Fish Bull. 122:1-67.
- Zimmerman, R.C., and J.N. Kremer. 1984. Episodic nutrient supply to a kelp forest ecosystem in southern California. J. Mar. Res. 42:591-604.
- ZoBell, C.E. 1956. Relation of marine bacteria to flora and fauna. Pages 170-176 in C.E. ZoBell, ed. Marine microbiology: a monograph on hydrobiology. Chronica Botanica Co., Mass.
- ZoBell, C.E. 1971. Drift seaweeds on San Diego County beaches. Nova Hedwigia 32:269-314.

## 2. ADDRESSES OF PERSONS CITED AS PERSONAL COMMUNICATIONS

Ainley, D.G.  
Point Reyes Bird Observatory  
Stinson Beach, CA 94970

Baldrige, A.  
Hopkins Marine Station of Stanford  
University  
Pacific Grove, CA 93950

Barilotti, D.C.  
Kelco Company  
P.O. Box 13216  
San Diego, CA 92113

Bonnell, M.L.  
Center for Coastal Marine Studies  
University of California  
Santa Cruz, CA 95064

Carr, M.  
Department of Biological Sciences  
University of California  
Santa Barbara, CA 93106

Carter, J.  
Kinnetic Labs  
5365 Avenida Encinitas, Suite H  
Carlsbad, CA 92008

Cowen, R.  
Scripps Institution of  
Oceanography, A-008  
La Jolla, CA 92093

Croll, D.A.  
Moss Landing Marine Laboratories  
P.O. Box 450  
Moss Landing, CA 95039-0450

Dean, T.A.  
Kelp Ecology Project  
531 Encinitas Blvd., Suite 118  
Encinitas, CA 92024

Deysher, L.  
Kelp Ecology Project  
531 Encinitas Blvd., Suite 118  
Encinitas, CA 92024

Dixon, J.  
Kelp Invertebrate Project  
531 Encinitas Blvd., Suite 113  
Encinitas, CA 92024

Druehl, L.  
Department of Biological Sciences  
Simon Fraser University  
Burnaby 2, British Columbia  
Canada

Ebert, E.  
California Department of Fish and Game  
Granite Canyon Mariculture Lab  
2201 Garden Road  
Monterey, CA 93940

Estes, J.  
USFWS  
Center for Coastal Marine Studies  
University of California  
Santa Cruz, CA 95064

Gerard, V.  
Marine Sciences Research Center  
State University of New York  
Stony Brook, NY 11794

Harrold, C.  
Center for Coastal Marine Studies  
University of California  
Santa Cruz, CA 95064

Jameson, R.  
USFWS  
Piedras Blancas Field Station  
P.O. Box 67  
San Simeon, CA 93452-0067

Keating, T.  
Moss Landing Marine Laboratories  
P.O. Box 450  
Moss Landing, CA 95039-0450

Kennelly, S.  
Department of Zoology  
University of Sydney  
Sydney, N.S.W. 2006  
Australia

Kimura, S.  
Tera Corp.  
P.O. Box 400  
Avila Beach, CA 93424-400

Laur, D.  
Department of Biological Sciences  
University of California  
Santa Barbara, CA 93106

Martin, L.  
Monterey Bay Aquarium  
Monterey, CA 93940

McPeak, R.  
Kelco Company  
P.O. Box 13216  
San Diego, CA 92113-13216

Miller, D.J.  
c/o California Department of Fish and Game  
2201 Garden Road  
Monterey, CA 93940

North, W.J.  
California Institute of Technology  
W.M. Keck Engineering Laboratories  
Pasadena, CA 92125

Pearse, J.S.  
Center for Coastal Marine Studies  
University of California  
Santa Cruz, CA 95064

Reed, D.  
Department of Biological Sciences  
University of California  
Santa Barbara, CA 93106

Schroeter, S.  
Kelp Invertebrate Project  
531 Encinitas Blvd., Suite 113  
Encinitas, CA 92024

Van Blaricom, G.  
USFWS  
Center for Coastal Marine Studies  
University of California  
Santa Cruz, CA 95064

Zimmerman, R.  
Department of Biological Sciences  
University of Southern California  
Los Angeles, CA 90089

REPORT DOCUMENTATION PAGE	1. REPORT NO. Biological Report 85(7.2)	2.	3. Recipient's Accession No.
4. Title and Subtitle The Ecology of Giant Kelp Forests in California: A Community Profile		5. Report Date May 1985	
7. Author(s) Michael S. Foster and David R. Schiel		6.	
9. Performing Organization Name and Address Moss Landing Marine Laboratories P.O. Box 450 Moss Landing, California 95039-0450		8. Performing Organization Rept. No.	
12. Sponsoring Organization Name and Address National Coastal Ecosystems Team Fish and Wildlife Service Division of Biological Services Washington, DC 20240		10. Project/Task/Work Unit No.	
		11. Contract(C) or Grant(G) No. (C) (G)	
		13. Type of Report & Period Covered	
15. Supplementary Notes		14.	
16. Abstract (Limit: 200 words)			
<p>Giant kelp forests are marine communities dominated by the large brown alga, <u>Macrocystis pyrifera</u>. In the northern hemisphere, stands of this species occur along the outer coast of the eastern Pacific from near Santa Cruz in central California to the central coast of Baja California, Mexico. Plants are usually attached to rocky substrata at depths of 5-20 m. These submarine forests are probably the most species-rich, structurally complex and productive communities in temperate waters.</p> <p>This profile reviews the relevant literature (over 400 citations) describing <u>M. pyrifera</u>, the organisms associated with it, the interactions among these organisms, and environmental factors that affect the distribution and structure of the community. The state of our knowledge about giant kelp forests is summarized, and suggestions are made for future research and management.</p>			
17. Document Analysis			
a. Descriptors			
Giant kelp, <u>Macrocystis pyrifera</u> , Distribution, Abundance, Hypotheses, Review, Community Structure, Understory Algae, Invertebrates, Fish, Birds, Mammals, Resource Use, Management			
b. Identifiers/Open-Ended Terms			
Kelp Forests, California, Baja California, Subtidal Community, Ecology, Marine			
c. COSATI Field/Group			
18. Availability Statement Unlimited		19. Security Class (This Report) Unclassified	21. No. of Pages 152
		20. Security Class (This Page) Unclassified	22. Price