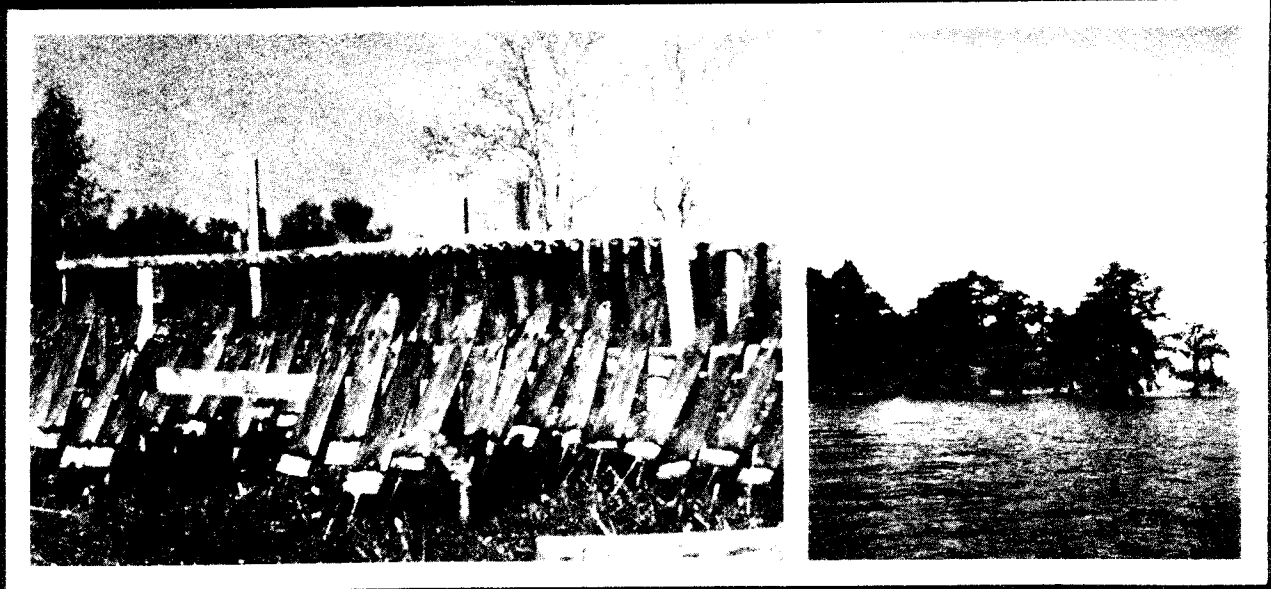


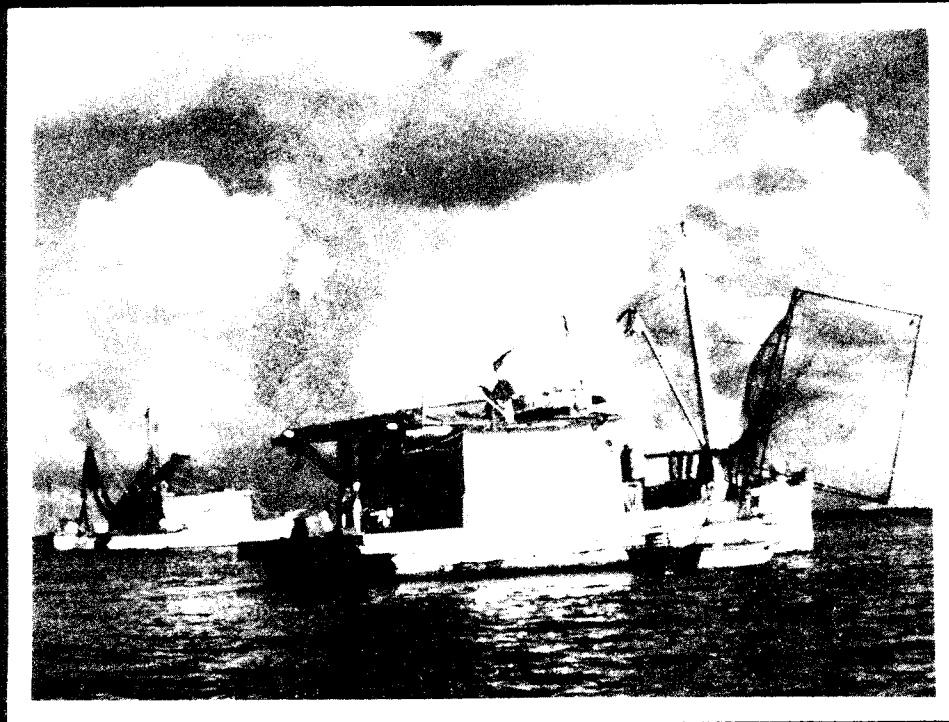
---

Biological Report 85(7.13)

July 1987



## **THE ECOLOGY OF BARATARIA BASIN, LOUISIANA:**



**AN  
ESTUARINE  
PROFILE**

Fish and Wildlife Service

---

U.S. Department of the Interior

Cover photos:

Top:

Nutria pelts being prepared for market. Swamp forest in upper Barataria Basin.

Bottom:

Shrimp trawlers in Barataria Bay.

Biological Report 85(7.13)  
July 1987

**THE ECOLOGY OF BARATARIA BASIN, LOUISIANA:  
AN ESTUARINE PROFILE**

edited by

William H. Conner

and

John W. Day, Jr.

Coastal Ecology Institute  
Center for Wetland Resources  
Louisiana State University  
Baton Rouge, LA 70803

Project Officer

Edward C. Pendleton  
National Wetlands Research Center  
U.S. Fish and Wildlife Service  
1010 Gause Boulevard  
Slidell, LA 70458

Performed for

National Wetlands Research Center  
U.S. Fish and Wildlife Service  
U.S. Department of the Interior  
Washington, DC 20240

### DISCLAIMER

The opinions and recommendations expressed in this report are those of the authors and do not necessarily reflect the views of the U.S. Fish and Wildlife Service, nor does the mention of trade names constitute endorsement or recommendation for use by the Federal Government.

#### Library of Congress Cataloging-in-Publication Data

The Ecology of Barataria Basin, Louisiana.

(Biological report ; 85 (7.13))

Bibliography: p.

"July 1987."

1. Estuarine ecology--Louisiana--Barataria Bay.

I. Conner, William H. II. Day, John W. III. Pendleton, Edward C. IV. National Wetlands Research Center (U.S.)

V. Series: Biological report (Washington, D.C.) ; 85-7.13.

QH105.L8E26 1987 574.5'26365 87-18475

This report may be cited as:

Conner, W.H., and J.W. Day, Jr., eds. 1987. The ecology of Barataria Basin, Louisiana: an estuarine profile. U.S. Fish Wildl. Serv. Biol. Rep. 85 (7.13). 165 pp.



## PREFACE

This estuarine profile is one of a series of publications concerning estuarine areas of the United States. The purpose of this profile is to synthesize existing information on the Barataria Basin, Louisiana. The basin is one of the interdistributary sub-estuaries of the Mississippi deltaic plain. Habitats in the basin vary from swamp forest to marine open water. Scientific study of the basin is important for a number of reasons. The area supports a variety of habitats and is very productive. Studies of such an area lead to a better understanding of the ecological functioning of large scale ecosystems. The area is economically valuable. Important activities include commercial and recreational fishing, hunting, trapping, and forestry. Information is needed to properly manage and sustain these resources. Finally, there are a number of serious environmental problems in the area. These include wetland deterioration, saltwater intrusion, eutrophication, and toxins. Scientific information can lead to an understanding of both the causes and solutions of these problems.

Ecosystem studies began in the basin in the late 1960's with studies in the saline marshes and water bodies of the lower basin. With a growing realization that the basin was, in a sense, a single ecological system, study was initiated in other parts of the basin. Studies were initiated in the freshwater forested wetlands in the headwaters of the basin and later in fresh and brackish marsh areas in the central part of the basin. Results of these studies showed that human activity was a dominant force shaping ecological processes. Thus, study began to address human impacts directly and much of the research today is directed at management.

The authorship of the various chapters is suggestive of the integrated approach which has characterized study of the basin.

Any questions or comments about or requests for this publication should be directed to:

Information Transfer Specialist  
National Wetlands Research Center  
U.S. Fish and Wildlife Service  
NASA - Slidell Computer Complex  
1010 Gause Boulevard  
Slidell, LA 70458.

## CONTENTS

	<u>Page</u>
PREFACE . . . . .	iii
FIGURES . . . . .	viii
TABLES . . . . .	xi
CONVERSION TABLE . . . . .	xiii
ACKNOWLEDGMENTS . . . . .	xiv
LIST OF CONTRIBUTORS . . . . .	xv
KEY TO TERMS AND SYMBOLS USED . . . . .	xvi
CHAPTER 1. DESCRIPTION OF THE BASIN by W.H. Conner and J.W. Day, Jr. . . . .	1
1.1 Introduction and Physical Setting. . . . .	1
1.2 Human Settlement and Impact on the Basin . . . . .	2
1.3 Hydrology . . . . .	4
1.4 Biological Zones . . . . .	5
1.4.1 Levee and Developed Land . . . . .	5
1.4.2 Swamp Forest . . . . .	5
1.4.3 Fresh Marsh . . . . .	6
1.4.4 Brackish Marsh . . . . .	7
1.4.5 Salt Marsh . . . . .	7
1.4.6 Offshore. . . . .	7
CHAPTER 2. PHYSICAL VARIABLES by R.H. Baumann . . . . .	8
2.1 Introduction . . . . .	8
2.2. Climate . . . . .	8
2.3 Water Level Variations . . . . .	9
2.3.1 Tides . . . . .	9
a. Biweekly Tidal Range Cycle . . . . .	10
b. Seasonal Tidal Range Cycle . . . . .	10
c. The 18.6-Year Tidal Range Cycle . . . . .	11
2.3.2 Nontidal Water Level Variations . . . . .	11
2.3.3 Short-Term Impact of Weather Events . . . . .	11
2.3.4 Seasonal Water Level Variation . . . . .	12
2.3.5 Seasonal Inundation of Estuarine Wetlands . . . . .	13
2.3.6 Seasonal Salinity . . . . .	15
2.3.7 Long-Term Water Level Variation . . . . .	16
2.4 Sedimentation . . . . .	16
2.5 Human Perturbations . . . . .	17
CHAPTER 3. CHEMISTRY AND NUTRIENT DYNAMICS by C.J. Madden and R.D. DeLaune . . . . .	18

	<u>Page</u>
3.1 Introduction . . . . .	18
3.2 Upper Basin Nutrient Profile and Trophic State . . . . .	19
3.2.1 Drainage Density and Trophic State . . . . .	20
3.2.2 Nutrient Uptake, Productivity, and Export . . . . .	22
3.3 Middle Basin Nutrients . . . . .	23
3.4 Lower Basin Nutrient Dynamics . . . . .	26
3.5 Summary . . . . .	30
CHAPTER 4. VEGETATION: COMPOSITION AND PRODUCTION by W.H. Conner, J.W. Day, Jr., J.G. Gosselink, C.S. Hopkinson, Jr., and W.C. Stowe . . . . .	31
4.1 Introduction . . . . .	31
4.2 Aquatic Primary Production . . . . .	31
4.2.1 Lac des Allemands . . . . .	31
4.2.2 Central Basin . . . . .	32
4.2.3 Nearshore Gulf . . . . .	35
4.3 Wetlands of The Barataria Basin . . . . .	35
4.3.1 Swamp Forest . . . . .	36
4.3.2 Fresh Marsh . . . . .	38
4.3.3 Brackish Marsh . . . . .	39
4.3.4 Salt Marsh . . . . .	39
4.4 Wetland Productivity . . . . .	40
4.4.1 Swamp Forest . . . . .	40
4.4.2 Marshes . . . . .	42
4.5 Factors Affecting Marsh Productivity . . . . .	43
4.6 Salt Marsh Epiphytic Algae . . . . .	47
CHAPTER 5. ZOOPLANKTON by W.H. Conner and J.W. Day, Jr. . . . .	48
5.1 Introduction . . . . .	48
5.2 Species Composition and Distribution . . . . .	49
5.2.1 Freshwater . . . . .	52
5.2.2 Brackish Waters . . . . .	53
5.2.3 Inshore Salt Waters . . . . .	54
5.2.4 Coastal Waters. . . . .	54
5.3 Temporal Variability . . . . .	55
5.4 Factors Affecting Zooplankton Densities . . . . .	55
5.4.1 Biological Factors . . . . .	55
5.4.2 Physical Factors . . . . .	56
5.5 Food Habits . . . . .	56
CHAPTER 6. BENTHOS by W.B. Sikora and F.H. Sklar . . . . .	58
6.1 Benthic Swamp Communities . . . . .	58
6.1.1 Introduction . . . . .	58
6.1.2 Distribution and Abundance . . . . .	58
6.1.3 Seasonality of Swamp Benthos . . . . .	62
6.1.4 Factors Affecting Swamp Benthos . . . . .	63
6.1.5 Trophic and Ecological Relationships . . . . .	65
6.2 Benthic Estuarine and Marine Communities . . . . .	68
6.2.1 Introduction . . . . .	68

	<u>Page</u>
6.2.2 Physical Factors . . . . .	69
6.2.3 Open Water Habitats . . . . .	69
6.2.4 Seasonal Patterns of Abundance . . . . .	72
6.2.5 Crustacea . . . . .	73
6.2.6 Meiofauna . . . . .	75
6.2.7 Oyster Community . . . . .	75
6.2.8 Discussion . . . . .	77
 CHAPTER 7. NEKTON by B.A. Thompson and W. Forman . . . . .	 80
7.1 Introduction . . . . .	80
7.2 Finfish . . . . .	86
7.2.1 Composition . . . . .	86
7.2.2 Temporal Patterns . . . . .	89
7.3 Invertebrates . . . . .	90
7.4 Community Dynamics . . . . .	92
7.4.1 Physical Factors . . . . .	92
7.4.2 Environmental Factors . . . . .	93
a. Abiotic Factors . . . . .	93
b. Biotic Factors . . . . .	93
7.5 Nektonic Resources and Human Influence . . . . .	94
7.5.1 Sport, Recreational, and Commercial Fisheries . . . . .	94
7.5.2 Human Influence . . . . .	94
a. Water Quality . . . . .	94
b. Industrialization . . . . .	94
c. Erosion and Wetland Loss . . . . .	94
d. By-Catch . . . . .	95
 CHAPTER 8. WILDLIFE by R.K. Abernethy . . . . .	 96
8.1 Introduction . . . . .	96
8.2 Birds . . . . .	96
8.2.1 Distribution . . . . .	96
8.2.2 Seasonal Abundance . . . . .	98
8.2.3 Food Habits . . . . .	99
8.3 Mammals . . . . .	100
8.3.1 Distribution . . . . .	100
8.3.2 Seasonal Abundance . . . . .	102
8.3.3 Food Habits . . . . .	102
8.3.4 Populations . . . . .	103
8.4 Reptiles and Amphibians . . . . .	103
8.4.1 Distribution . . . . .	103
8.4.2 Food Habits . . . . .	106
8.4.3 Populations . . . . .	106
8.5 Endangered Species . . . . .	107
8.5.1 Brown Pelican . . . . .	107
8.5.2 Bald Eagle . . . . .	108
8.5.3 Bachman's Warbler ( <u>Vermivora bachmanii</u> ) . . . . .	108
8.5.4 Peregrine Falcon ( <u>Falco peregrinus</u> ) . . . . .	108
8.5.6 Sea Turtles . . . . .	108
8.6 Hunting and Trapping . . . . .	108

	<u>Page</u>
CHAPTER 9. REVIEW OF MODELING STUDIES IN THE BARATARIA BASIN by R. Costanza . . . . .	110
9.1 Introduction . . . . .	110
9.2 Hydrodynamic Models . . . . .	110
9.3 Ecosystem Models . . . . .	114
9.3.1 Static Material and Energy Budgets . . . . .	114
9.3.2 Dynamic Simulation Models . . . . .	115
9.4 Long-Term Management Models . . . . .	119
9.5 Summary and Conclusions . . . . .	121
 CHAPTER 10. MANAGEMENT ISSUES by N.J. Craig and J.W. Day, Jr. . . . .	 123
10.1 Introduction . . . . .	123
10.2 Wetland Loss . . . . .	123
10.2.1 Natural Wetland Loss . . . . .	124
10.2.2 Human-Induced Wetland Loss . . . . .	125
a. Canals . . . . .	125
b. Cumulative Impact Canals . . . . .	126
10.2.3 Management Strategies for Land Loss . . . . .	126
a. Canal Regulation . . . . .	126
b. Creative Use of Spoil . . . . .	126
c. Barrier Island Stabilization . . . . .	128
d. Controlled Diversions . . . . .	128
e. Controlled Diversion vs. Regulation of Canals . . . . .	129
10.3 Managing Eutrophication . . . . .	130
10.4 Management Options for Salt Water Intrusion . . . . .	132
10.5 Loss of Nursery Grounds . . . . .	134
10.5.1 Nursery Grounds: Past, Present, and Future . . . . .	134
10.5.2 Management for Protection of the Nursery Zone . . . . .	135
10.6 Toxic Substances . . . . .	135
10.6.1 Carcinogen Monitoring in Estuaries . . . . .	136
10.6.2 Toxic Substances Management Guidelines . . . . .	137
 CHAPTER 11. SYNTHESIS by J.W. Day, Jr., C.S. Hopkinson, W.H. Conner, and J.G. Gosselink . . . . .	 139
11.1 Factors Affecting Aquatic Primary Production . . . . .	139
11.2 The Role of Hydrology in the Ecodynamics of the Barataria Basin . . . . .	141
11.3 Wetlands and the Estuarine Carbon Budget . . . . .	142
11.4 The Role of the Marsh-Estuary in Fisheries Production . . . . .	143
 LITERATURE CITED . . . . .	 147

## FIGURES

<u>Number</u>	<u>Page</u>
1 Historical sequence of major delta lobes . . . . .	2
2 Generalized succession pattern in delta area . . . . .	3
3 Location map of the Barataria Basin . . . . .	3
4 Map showing the location of the Acadian and German coasts . . . . .	4
5 Major oil fields and pipelines in the basin . . . . .	5
6 Habitat map of the basin . . . . .	6
7 Average water budget for the upper basin . . . . .	9
8 Tidal amplitude for five stations in the basin . . . . .	10
9 Mean seasonal variation in tidal range . . . . .	10
10 Variation in yearly range in tide and effects on inundation of saline marsh . . . . .	11
11 Water level and salinity variations and water surplus . . . . .	12
12 Mean seasonal water level for selected stations . . . . .	13
13 Comparison of the seasonal inundation regimes for the saline marsh and swamp . . . . .	14
14 Long-term averaged monthly means of salinity, 1961-74 . . . . .	15
15 Mean weekly salinity at Lafitte . . . . .	15
16 Variation in yearly mean water level at selected stations . . . . .	16
17 Drainage network of the upper basin . . . . .	22
18 Phosphorus (P) and nitrogen (N) levels in the bayous . . . . .	23
19 Materials export from the upper basin . . . . .	25
20 Relationship of precipitation to N:P ratios in bayou and swamp waters . . . . .	26
21 Nutrient profile for Caminada Bay and nearshore gulf . . . . .	27
22 Aquatic productivity of the freshwater lakes and bayous . . . . .	32

<u>Number</u>	<u>Page</u>
23 Community gross production, net daytime photosynthesis, and nighttime respiration in three lakes . . . . .	33
24 Seasonal gross production curves for Airplane Lake . . . . .	35
25 Average primary productivity of offshore surface waters . . . . .	36
26 Percent of the year water levels exceed a specified height and the number of times water exceeds a specified height . . . . .	39
27 Seasonal biomass cycles of the major macroscopic algae in the salt marsh . . . . .	40
28 Water level fluctuations in three swamp areas . . . . .	41
29 Seasonal stem growth patterns for three tree species in the swamp . . . . .	41
30 Seasonal changes in live and dead biomass of seven marsh plants . . . . .	44
31 Live and dead standing crop of streamside and inland <u>Spartina alterniflora</u> . . . . .	46
32 Metabolic rates of the epiphytic community associated with <u>Spartina alterniflora</u> . . . . .	47
33 Location of zooplankton sampling stations . . . . .	48
34 Monthly zooplankton counts from upper and lower Barataria Bay . . . . .	54
35 Monthly zooplankton counts with <u>Acartia</u> separated out . . . . .	55
36 Seasonal abundance of zooplankton by habitat type . . . . .	56
37 Seasonal density variations for four dominant taxa in the swamp forest . . . . .	62
38 Proportion and average biomass of dominant benthic organisms by habitat . . . . .	63
39 Conceptual model of the backswamp carbon flows . . . . .	65
40 Location of benthic sampling stations . . . . .	70
41 Composition of aquatic fauna in relation to salinity . . . . .	72
42 Species-family relationships for fishes . . . . .	87
43 Diagrammatic representaion of major fish life cycles . . . . .	90
44 Egret, ibis, and heron rookery at Lake Boeuf . . . . .	97
45 Great egret in fresh marsh . . . . .	98
46 Muskrat eat-out in <u>Spartina patens</u> marsh . . . . .	103
47 Green tree frog . . . . .	106

<u>Number</u>	<u>Page</u>
48 Alligator nest in fresh marsh around Lake Boeuf . . . . .	107
49 Location map of salt marsh area used for water exchange model . . . . .	111
50 Water level changes with different intensities of canals and spoil banks . . . . .	112
51 Results of water level simulation model used in the swamp forest . . . . .	113
52 Nutrient budget for Lac des Allemands . . . . .	115
53 Simulation model of the salt marsh . . . . .	117
54 Simulation model of an impounded swamp forest . . . . .	118
55 Energy and material flow for New Orleans . . . . .	120
56 Conceptual model relating land use to storm water and nutrient runoff . . . . .	121
57 Conceptual model of natural and artificial land loss . . . . .	122
58 Potential freshwater diversion sites . . . . .	129
59 Local drainage density versus trophic state index . . . . .	132
60 Past and present water movement in the central basin . . . . .	133
61 Estimated phosphorus loading rate and salinity . . . . .	135
62 Elevation range of <u>Spartina alterniflora</u> vesus tidal range . . . . .	141
63 Patterns of estuarine use by nektonic organisms . . . . .	144



## TABLES

<u>Number</u>	<u>Page</u>
1 Areal extent of major ecological habitats . . . . .	6
2 Mean sedimentation rates in various wetland environments . . . . .	17
3 Average yearly nutrients, secchi, and chlorophyll <i>a</i> concentrations at several sites . . . . .	20
4 Trophic state classification . . . . .	21
5 Comparative aquatic productivity and chlorophyll <i>a</i> concentrations from freshwater to offshore . . . . .	34
6 Plant species composition of the marshes . . . . .	37
7 Aboveground net primary production in three swamp sites . . . . .	41
8 Estimated aboveground net primary production for each marsh type . . . . .	42
9 Zooplankton list . . . . .	49
10 Zooplankton concentrations and species diversity counts . . . . .	53
11 Checklist of benthic organisms . . . . .	58
12 Average density per square meter for each taxa . . . . .	61
13 Environmental differences among swamp sites . . . . .	64
14 Steady state variables, forcing functions, and organic flow averages for a natural backswamp . . . . .	66
15 Environmental characteristics of benthic sampling stations . . . . .	71
16 Summary table of crustacea reported from Barataria system by author . . . . .	73
17 Salinity relations of some common animals on Louisiana oyster beds . . . . .	76
18 Abundance comparison of major benthic taxa . . . . .	78
19 Ecological classification of fishes . . . . .	80
20 Ecological affinity and number of families, species, and species/family for fishes in Mississippi Deltaic Plain . . . . .	86
21 Fish families ranked by numbers of species . . . . .	88

<u>Number</u>	<u>Page</u>
22 Similarity of the fish fauna in Barataria Basin with other gulf coast estuaries . . . . .	89
23 Abundance and biomass of fish assemblages of the upper and lower basin . . . . .	89
24 Groupings of animals of Barataria Basin . . . . .	97
25 Major food items of wading birds . . . . .	99
26 Primary food items from 1,251 waterfowl . . . . .	100
27 Checklist of the mammals of Barataria Basin . . . . .	101
28 Reptiles and amphibians of Barataria Basin . . . . .	104
29 Numbers of several reptile species in Barataria Basin . . . . .	105
30 Numbers of reptiles and amphibians by habitat type . . . . .	105
31 Alligator population estimates by marsh zone and type . . . . .	107
32 Stomach contents of alligators . . . . .	107
33 Example of habitat input-output table for the salt marsh . . . . .	116
34 Selected use-issue categories and human activities in coastal Louisiana . . . . .	124
35 Recommendations to minimize the impact of canals . . . . .	127
36 Comparison of swamp barge to marshland air cushion drilling . . . . .	128
37 Characterization of habitat development field sites . . . . .	128
38 Effect of different mitigation techniques for reducing wetland loss . . . . .	130
39 Permissible loading levels for total nitrogen and phosphorus . . . . .	131
40 Critical concentrations and loading rates for nitrogen and phosphorus . . . . .	131
41 Physical characteristics of waterbodies in Barataria Basin . . . . .	139
42 Estimates of new and remineralized nitrogen . . . . .	140
43 Annual organic carbon budget . . . . .	143

## CONVERSION TABLE

### Metric to U.S. Customary

<u>Multiply</u>	<u>By</u>	<u>To Obtain</u>
millimeters (mm)	0.03937	inches
centimeters (cm)	0.3937	inches
meters (m)	3.281	feet
meters (m)	0.5468	fathoms
kilometers (km)	0.6214	statute miles
kilometers (km)	0.5396	nautical miles
square meters (m <sup>2</sup> )	10.76	square feet
square kilometers (km <sup>2</sup> )	0.3861	square miles
hectares (ha)	2.471	acres
liters (l)	0.2642	gallons
cubic meters (m <sup>3</sup> )	35.31	cubic feet
cubic meters (m <sup>3</sup> )	0.0008110	acre-feet
milligrams (mg)	0.00003527	ounces
grams (g)	0.03527	ounces
kilograms (kg)	2.205	pounds
metric tons (t)	2205.0	pounds
metric tons (t)	1.102	short tons
kilocalories (kcal)	3.968	British thermal units
Celsius degrees (°C)	1.8(°C) + 32	Fahrenheit degrees

### U.S. Customary to Metric

inches	25.40	millimeters
inches	2.54	centimeters
feet (ft)	0.3048	meters
fathoms	1.829	meters
statute miles (mi)	1.609	kilometers
nautical miles (nmi)	1.852	kilometers
square feet (ft <sup>2</sup> )	0.0929	square meters
square miles (mi <sup>2</sup> )	2.590	square kilometers
acres	0.4047	hectares
gallons (gal)	3.785	liters
cubic feet (ft <sup>3</sup> )	0.02831	cubic meters
acre-feet	1233.0	cubic meters
ounces (oz)	28350.0	milligrams
ounces (oz)	28.35	grams
pounds (lb)	0.4536	kilograms
pounds (lb)	0.00045	metric tons
short tons (ton)	0.9072	metric tons
British thermal units (Btu)	0.2520	kilocalories
Fahrenheit degrees (°F)	0.5556 (°F - 32)	Celsius degrees

## **ACKNOWLEDGMENTS**

Research in the Barataria Basin has been ongoing in the Center for Wetland Resources, Louisiana State University, Baton Rouge, since 1970. A large number of faculty, staff, and students have participated in a variety of projects looking at the various habitats from a number of different aspects. This profile is an attempt to bring together most of that information and try to present to the reader a comprehensive overview of the basin and how it functions.

Although the funding for these projects has come from a variety of sources, the major contributor has been the Louisiana Sea Grant College Program, a part of the National Oceanic and Atmospheric Administration. Other funds have come from private industry and State and federal agencies such as the Louisiana Board of Regents, the National Science Foundation, and the Environmental Protection Agency.

Gerry Bodin, Michael Brody, Charles Hopkinson, Ed Pendleton, and David White reviewed this document. Dana Criswell edited the report, Cresap Watson proofread it, and Sue Lauritzen was responsible for layout.

## LIST OF CONTRIBUTORS

A number of people contributed to the writing of this profile. To allow the reader to contact someone about more detailed information than we were able to give in this report, we present here the address of each author.

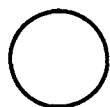
John W. Day, Jr. William H. Conner Christopher J. Madden James G. Gosselink R. Eugene Turner Walter B. Sikora Fred H. Sklar Robert Costanza	Coastal Ecology Institute Center for Wetland Resources Louisiana State University Baton Rouge, LA 70803
Ron D. DeLaune	Wetland Soils and Sediments Laboratory Louisiana State University Baton Rouge, LA 70803
Robert H. Baumann	Center for Energy Studies Louisiana State University Baton Rouge, LA 70803
Charles S. Hopkinson, Jr.	Marine Institute-Zoology Department University of Georgia Sapelo, GA 31327
Wayne Forman	Freeport Sulphur Box 61520 New Orleans, LA 70160
Bruce A. Thompson	Coastal Fisheries Institute Center for Wetland Resources Louisiana State University Baton Rouge, LA 70803
Nancy J. Craig	Louisiana Heritage Program Department of Natural Resources P.O. Box 44124 Baton Rouge, LA 70804
Robert Abernethy	Department of Conservation Division of Ecological Services 701 Broadway Nashville, TN 37203

## KEY TO TERMS AND SYMBOLS USED

### Salinity classification (Cowardin et al. 1979)

Fresh - <0.5 ppt  
Oligohaline - 0.5 to 5 ppt  
Mesohaline - 5 to 18 ppt  
Polyhaline - 18 to 30 ppt

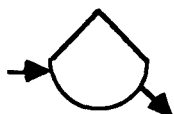
### Energy diagram symbols (after Odum 1983)



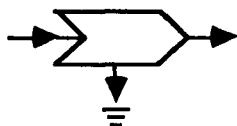
Energy source from outside accompanied by causal forces.



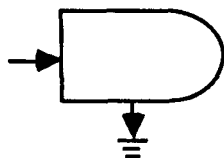
Heat sink, the draining of degraded energy after use in work.



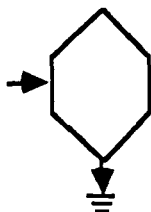
Energy storage tank delivers energy flow to pathways.



Energy interaction, where 2 kinds of energy are required to produce high-quality energy flow.



Producer unit converts and concentrates solar energy; it is self-maintaining.



Consumer unit uses high-quality energy and is self-maintaining.

# CHAPTER 1

## DESCRIPTION OF THE BASIN

by

W.H. Conner and J.W. Day, Jr.

### 1.1 INTRODUCTION AND PHYSICAL SETTING

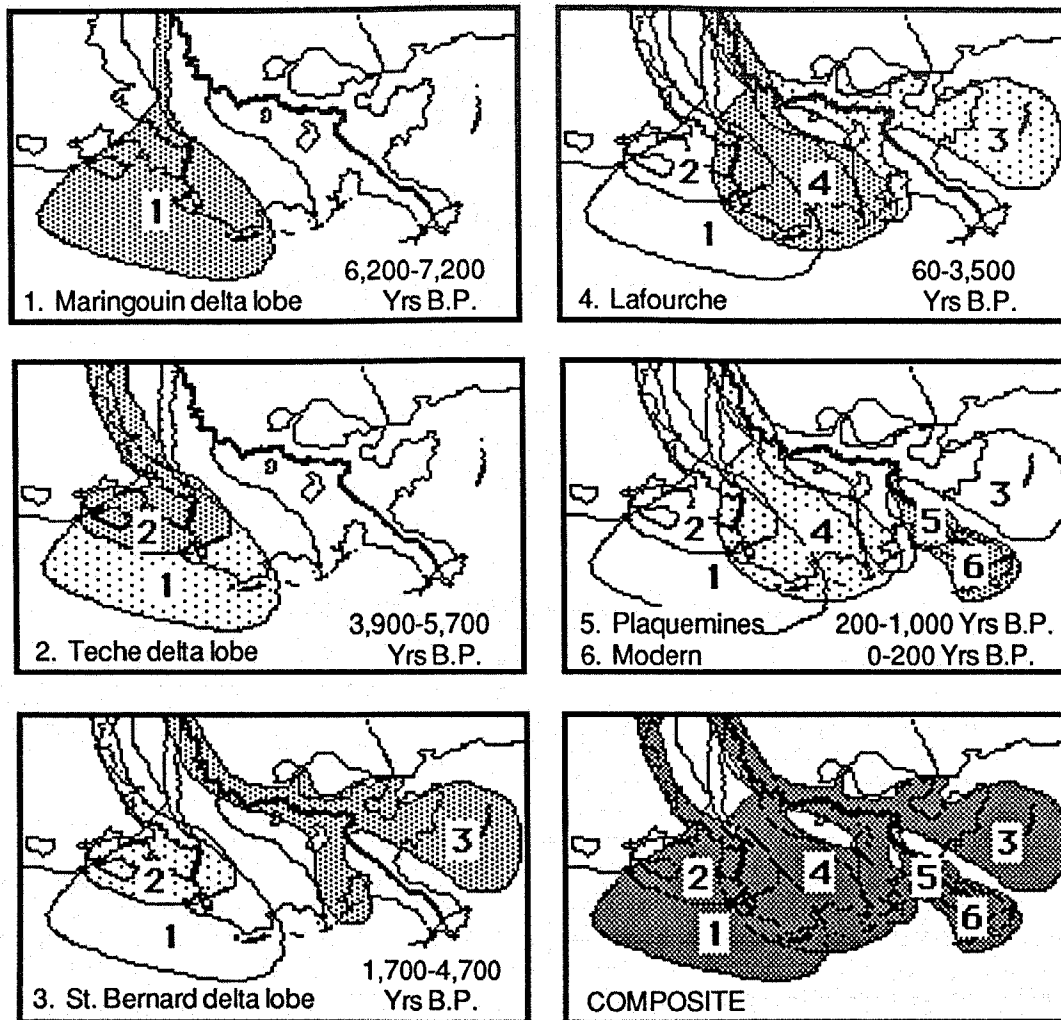
Coastal Louisiana was formed as a result of sedimentation by the Mississippi River over the past several thousand years (Morgan 1967). Frequent channel changes by the Mississippi River have created broad areas of near sea level wetlands (Kolb and Van Lopik 1958; Figure 1). In an active delta sedimentation exceeds erosion, while in an abandoned delta the reverse is true. As channels extend into the shallow Gulf of Mexico waters, high ridges or natural levees form adjacent to the streams from the deposition of coarse suspended sediments. Lower elevations in the back of the natural levees contain much finer sediments and support wetland vegetation (Figure 2). Most estuarine systems of the Mississippi Deltaic Plain are thus located in an interdistributary position, that is, between the higher ridges of the Mississippi distributaries (Russell 1936).

The Barataria Basin is an example of such an interdistributary estuarine-wetland system. It is located between the natural levees of the active Mississippi River and the abandoned Bayou Lafourche distributary (Figure 3). The basin is roughly triangular in shape, with its apex at Donaldsonville. It is about 110 km long and 50 km wide at its largest point where it meets the Gulf of Mexico. Since the river occupied its present channel about 700 years ago, there has been little sedimentation in most of the basin (Morgan 1967). Since that time bays, lakes and, bayous have enlarged by subsidence and erosion to form an

extensive network of interconnecting waterbodies which allow transport of water, materials and migrating organisms throughout the basin (Fisk and McFarlan 1955; Coleman and Gagliano 1964; Morgan 1967, 1972).

Salient morphological features characterizing the area include natural and artificial levees, water bodies (such as bays, lakes, and bayous), coastal beaches and barrier islands, and swamp and marsh wetlands. The lower portion of the Barataria Basin is a typical bar-built estuary. It is shallow with bars at the mouth and a low-tide, low energy coast (Adams et al. 1976). The natural levees and barrier islands are the only high, well-drained ground in the basin, and thus have been the primary sites of human habitation. The coastline is primarily beach-dune systems with tidal flats and marshes in protected areas behind the barrier shores (Morgan 1967). Barrier islands protect the estuarine environment from waves and currents that would otherwise cause much more rapid erosion of wetlands.

The basin is still an extremely dynamic system undergoing constant change because of geologic and human processes. The basin has been closed to river flow since the leveeing of the Mississippi River in the 1930-40's and the closing of the Bayou Lafourche-Mississippi River connection in 1902. A small amount of water enters the basin through the Intercoastal Canal via the locks in New Orleans. Precipitation provides the main source of freshwater for the basin. During periods of high water on the Mississippi River and



**Figure 1.** Historical sequence of major distributary delta lobes in the Mississippi Deltaic Plain (Baumann and Adams 1981).

given certain wind and sea conditions, freshwater from the river can exert some influence on the lower part of the basin.

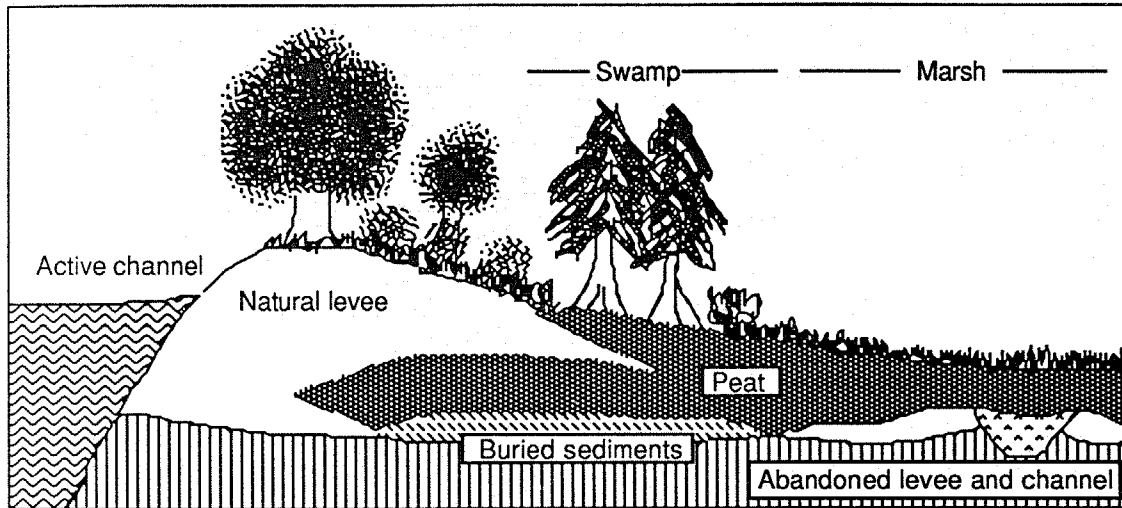
## 1.2 HUMAN SETTLEMENT AND IMPACT ON THE BASIN

The first people to populate Louisiana in prehistoric times probably found that the coastal marshes provided an abundance of food. Gathering and hunting were the primary sources of food for these early settlers, and *Rangia* clam was probably one of the most dependable sources of food, as numerous shell middens are found throughout the coastal region of the state. Since there were no roads in the area, streams were ideal

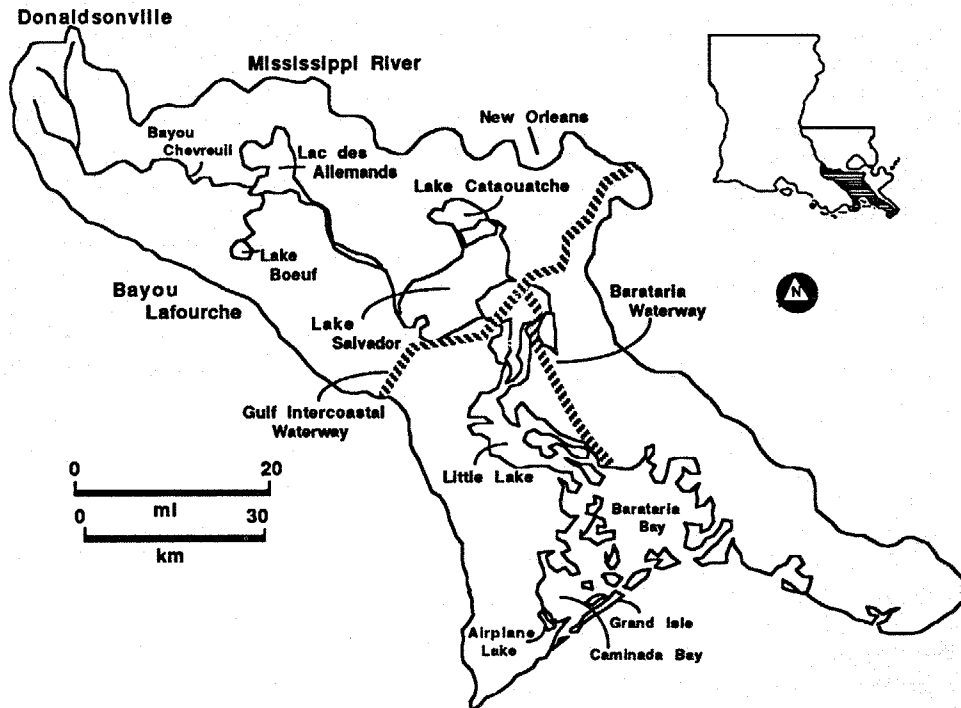
highways for the early settlers. The floodplains of the major streams were also ideal areas for living and represented prime agricultural land when agriculture later became important.

The first European settlers to the basin arrived in the region in the 1700's and settled along the natural levees of the Mississippi River and Bayou Lafourche. Agriculture was important to the new arrivals and they planted indigo, tobacco, rice, and vegetable crops. Two of the most important groups of settlers to the area were the Germans and the Acadians. The Germans settled in St. Charles and St. John the Baptist Parishes, especially the area around Lac des Allemands (Figure 4). Most of these hard-working

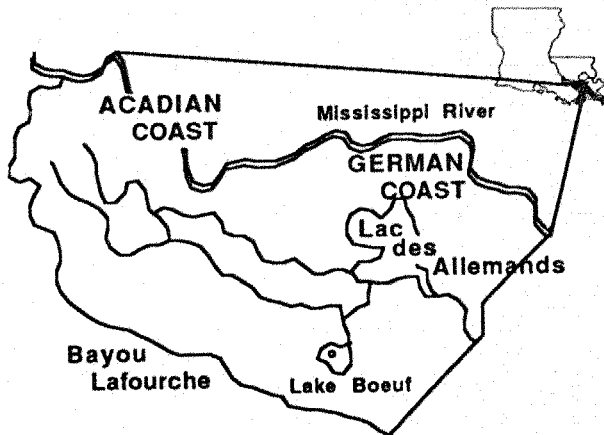




**Figure 2.** Generalized succession pattern in the delta area. With an active channel, there is maximum development of a natural levee. Behind the natural levee, swamp and marsh may form as the levee subsides.



**Figure 3.** Location map of the Barataria Basin. The location and names of the most commonly referred to places in the text are shown.



**Figure 4.** Map of the upper Barataria Basin showing the location of the Acadian and German coasts (reprinted, with permission, from Kniffen 1968, copyright LSU Press).

farmers raised produce to sell in New Orleans. These settlers lost their language and identity as they were absorbed by the French population. The Acadians first settled in the northern part of the basin and extended down the broad levees of Bayou Lafourche. These people were devout Catholics and held strongly to their traditions. They absorbed nearly every group with which they came in contact and still represent a significant portion of the population in the basin.

One of the most important factors that has influenced settlement in the basin has been flooding by the Mississippi River. Flooding has always occurred on the river. The Indians knew to live on the higher sections of land and plant their crops on the rich floodplains after the floodwaters receded. The European settlers, however, settled all along the natural levees, extended their fields back to the swamp, and built their towns right on the rivers. There was no way the settlers could escape flood damage. Thus began the fight to control the river by building levees. At first, each landowner was responsible for building and maintaining the levees along his property, but this did not work very well. In 1927, after a particularly destructive flood, the United States Corps of Engineers took over the planning and construc-

tion of the levees. By the 1940's, the entire Mississippi River was leveed and the Barataria Basin no longer received any overflow of the rich, sediment-laden waters.

The Barataria Basin is mainly composed of cypress-tupelo swamp in its upper headwater region. Lumbermen soon found that cypress was an excellent wood for building. Because of its location in the wettest parts of the state, however, it was difficult to harvest. This had changed by 1890, with the invention of steam equipment to pull the logs out of the swamps. Cypress lumbering began in earnest and peaked in 1913 with 755 million board ft being harvested in the state (Mattoon 1915). A large portion of the lumber came from the Barataria Basin area, and numerous cypress mills were located in the area. By 1925 all the virgin stands of cypress were logged and only a few individual virgin cypress exist today in the basin. The construction of canals and railroad lines in the swamp severely altered the natural hydrology of much of the basin.

Perhaps the greatest activity that has altered the entire basin is the search for, and extraction of, oil and gas. The greatest concentration of oil and gas in the state lies in the modern Mississippi delta and just to the west of the Mississippi River, especially in the Barataria Basin (Figure 5). Oil pipeline canals form an intricate network in the basin. Hydrologic patterns have been drastically altered and recent studies (Turner et al. 1982; Johnson and Gosselink 1982; Scaife et al. 1983) have shown that the large amount of land lost in the basin may be related directly and indirectly to the construction of these canals.

### 1.3 HYDROLOGY

Hydrology is an extremely important integrating factor in the basin. Water is the major transport mechanism among waterbodies, wetlands, and the gulf, carrying suspended silt and clays, nutrients, and organic material throughout the basin. The rate of water movement is a function of tide range (about 0.3 m at the coast), wind, precipitation, and the gradual slope of the land from the cypress swamps to the gulf (about 1.0 cm/km). These conditions create sluggish bayous and promote overland sheet flow through the wetlands. Hydrology is treated in detail in the next chapter, and its importance is discussed throughout this estuarine profile.

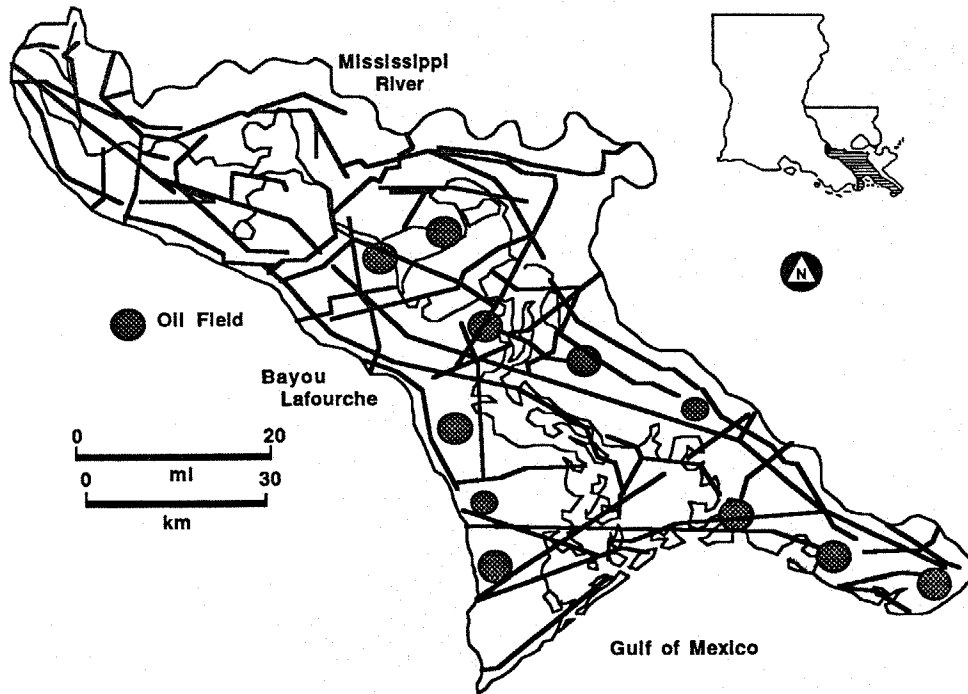


Figure 5. Major oil fields and pipelines within the Barataria Basin (modified from Adams et al. 1976). At this scale the intricate pattern of crisscrossing small canals within the basin cannot be shown.

#### 1.4 BIOLOGICAL ZONES

The Barataria Basin is divided into five environmental units: levee and developed lands, swamp forest, fresh marsh, brackish marsh, and salt marsh (Figure 6). Some authors separate brackish and intermediate marshes, but for the purposes of this profile, the two units will be combined. These units are treated in order of increasing salinity since the flow of water occurs in this direction and water is considered the major integrative element of the system.

##### 1.4.1 Levee and Developed Land

The highest and driest areas in the basin are found along the natural levee ridges of the Mississippi River and Bayou Lafourche. These levees were once covered with forests of hardwood trees. However, the majority of these forests have been cleared and are now used for agricultural, residential, and industrial purposes. Stands of American elm (*Ulmus americana*),

sweetgum (*Liquidambar styraciflua*), sugarberry (*Celtis laevigata*) and swamp red maple (*Acer rubrum* var. *drummondii*) can still be found in some areas.

##### 1.4.2 Swamp Forest

Vegetation in the swamp forest is predominantly baldcypress (*Taxodium distichum*) and water tupelo (*Nyssa aquatica*). There are about 100,000 ha of swamp in the Barataria Basin (Table 1) representing 16% of the basin. The ratio of land to water is highest here, but decreases moving seaward as waterbodies become a more dominant feature of the landscape. Soil in this unit is composed largely of clay (38%) which is mainly Mississippi River sediment.

Waterbodies in the swamp forest are mainly bayous, which tend to serve as conduits of excess swamp forest production. During flooding episodes, excess water floods the entire system. As this water flows through the forest, it picks up

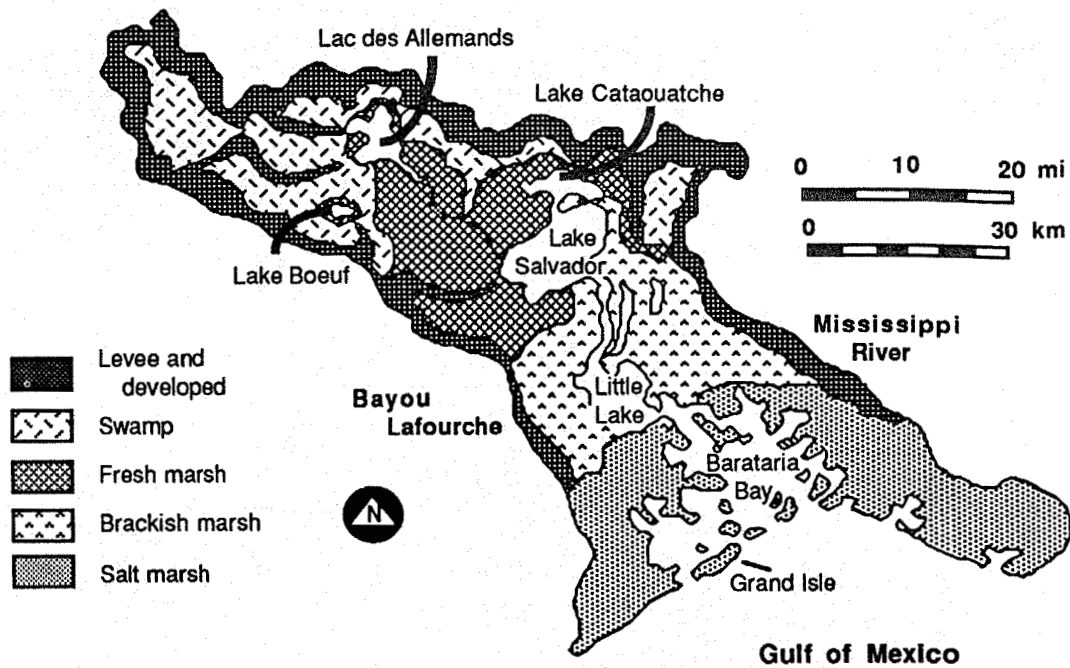


Figure 6. Habitat map of Barataria Basin.

detritus particles, organic decomposition products, and inorganic nutrients which are deposited in the bayous to be carried to units downstream.

#### 1.4.3 Fresh Marsh

The fresh marsh portion of the basin lies immediately below the swamp forest and contains about 155,000 ha (25% of the basin). Salinity averages 1.8 ppt (Chabreck 1972). Much of the freshwater marsh environmental unit is composed of "flotant" or floating marsh. Flotant marsh consists of dense mats of vegetation supported by detritus several feet thick, all held together by a matrix of living roots. Maidencane (*Panicum hemitomon*) is the dominant plant species, covering over 41 % of the total area. This species is seldom found in other wetland habitats, and even in the fresh marsh there are areas where it is a minor component or absent. Spikerush (*Eleocharis* sp.) and bulltongue (*Sagittaria falcata*) are also important species in the freshwater areas.

One of the most obvious differences between swamp and fresh marsh areas is the increased thickness of the organic soils. Detritus

Table 1. Areal extent of the major ecological habitats in the Barataria Basin hydrologic unit (modified from Hopkinson 1978).

Habitat	Area (ha)	Land:Water Ratio
<b>Levee and developed land</b>		
Land	122,352	54:1
Water	2,279	
<b>Swamp</b>		
Land	97,954	44:1
Water	2,202	
<b>Fresh marsh</b>		
Land	87,789	1.3:1
Water	67,240	
<b>Brackish marsh</b>		
Land	55,036	1.1:1
Water	48,263	
<b>Salt marsh</b>		
Land	63,356	0.8:1
Water	82,144	
<b>Total water</b>	202,128	
<b>Total marsh</b>	206,182	
<b>Total area</b>	628,619	

deposited in this environment remains partially undecomposed, resulting in the buildup of peat. The organic content of the soils in the fresh marsh is about 67%.

Waterbodies of importance in the fresh marsh include Lakes Cataouatche and Salvador and the surrounding bayous and canals. Primary production in these areas is overshadowed by the high concentration of organic material carried in from the surrounding swamps and marshes. The waterbodies are both highly eutrophic and heterotrophic.

#### 1.4.4 Brackish Marsh

Between the upper freshwater end of the basin and the lower marine end of the basin lies the brackish marsh area, which covers about 137,000 ha (22% of the basin). Both of the previously discussed units are characterized by unidirectional water flow in response to rainfall. The brackish marsh area is the first system that is strongly influenced by tides and storm surges, which affect water level, frequency and duration of flooding, and salinity. This zone represents an area where fine particulate organic and inorganic matter are trapped. Fresh water flowing from the upper basin encounters higher salinity water, and the ionic components in the salt water cause the fine suspended particles in the fresh water to flocculate out; salinity ranges from 2 to 10 ppt (Chabreck 1972). Even though there is a net movement of water downstream, the inland flow of tidal waters determines the kinds of vegetation that occur in the wetland, aids in the recirculation of nutrients, and allows the inland migration of larval forms of estuarine species. Saltmarsh cordgrass (Spartina patens) is the dominant plant in this area.

#### 1.4.5 Salt Marsh

More research has been done in this unit than in any of the others. The salt marsh is subject to modification by physical forces more than the other two types. There is one tidal cycle per day in the salt marsh, averaging 0.3 m in height, and salinity ranges from 6 to 22 ppt (Chabreck 1972). Storm surges and prolonged southerly winds can produce higher than average tides. There are approximately 145,000 ha of salt marsh in the basin, and the land to water ratio is the lowest of all the units in the basin. The major plant species in this unit is oyster grass (Spartina alterniflora), which covers 63% of the salt marsh area.

Interaction between wetland and waterbodies is more pronounced in the salt marsh than in any other unit. Because of the high proportion of water to land and the frequent flooding, it is difficult to distinguish between land and waterbody in many cases. The waterbodies are typically shallow and turbid with muddy substrate.

#### 1.4.6 Offshore

The excess organic matter produced by the marshes of the Barataria Basin eventually finds its way to the Gulf of Mexico through the bayous and canals that drain the basin. There is considerable evidence to support the importance of "outwelling" from the Barataria Basin to the gulf (Day et al. 1982). One of the major factors influencing the offshore areas is the presence of the Mississippi River. Millions of cubic meters of freshwater and tons of sediments and nutrients are dumped each day into the Gulf of Mexico only 80 km to the east of the basin. Rather than mixing immediately, the freshwater forms a large gyre that impinges on the Barataria Basin offshore area.

## CHAPTER 2

### PHYSICAL VARIABLES

by

R. H. Baumann

#### 2.1 INTRODUCTION

This chapter describes the major physical processes which are operative in the Barataria Basin. Emphasis is on water because it is the medium for material transport. Direct measurements of water flux through the basin are few, but analyses of various water level phenomena allow inferences regarding water movement and hence material transport. This chapter is concerned with identifying the water level change phenomena and discussing what regulates them and how they vary temporally and spatially. Humans have greatly affected the movement of water through the system and factors affecting physical processes also control, to varying extents, other components of the system. Several of these interrelationships are briefly mentioned to set the stage for the final chapter of this volume.

#### 2.2 CLIMATE

Climatic conditions in the Barataria Basin are largely determined by its subtropical location and its proximity to the Gulf of Mexico (Sanders 1959, 1978). Two pressure ridges dominate weather conditions along coastal Louisiana. One is the "Bermuda high" centered over the Bermuda-Azores area of the Atlantic in the winter, and the other is the "Mexican heat low" centered over Texas during the summer (Stone 1972). These ridges produce winds with an easterly component. Northeasterly winds are prevalent in the fall and winter, and southeasterly winds are dominant in the spring and summer. Northwesterly winds occur most often in the winter months. Warmer temperatures and higher humidities are associated with the southeasterly winds in the spring and summer months, and cooler, drier weather

accompanies the northerly winds that occur predominantly in the fall and winter. Highly variable winter weather results from alternating exposure to cold dry continental air masses originating in the north or northwest and warm, humid tropical systems centered in the Gulf of Mexico. Summer weather is generally more stable, with prevailing south-southeast winds providing moist subtropical conditions. Local summertime heating causes convective updrafts, vertical development of cumulus clouds, and frequent, localized thundershowers. Occasional continental air masses from the north or west move over the basin bringing decreased temperatures and humidities during the summer.

Mean annual precipitation in coastal Louisiana is fairly high at about 160 cm. Long-term averages indicate that rainfall is fairly uniformly spread throughout the year, but the maximum usually occurs in July, and the minimum in October (Sanders 1959, Stone 1972). There are, however, exceptions in annual and seasonal totals. Annual totals have varied from 92 to 219 cm, while seasonal extremes have ranged from 0 to 46 cm during the period 1914-78 (Sklar 1983).

Using a climatic water budget developed by Thornthwaite (1948) in conjunction with synoptic weather types, Wax et al. (1978) were able to determine periods of water surplus and deficit in Barataria Basin. They found a water surplus in winter and early spring when precipitation was high and potential evapotranspiration was low. Deficits occurred in summer and autumn when south winds and increased salinities predominated. Effects of surplus precipitation are far more noticeable over the inland or upper end of the basin (above Lake Salvador), where runoff is

concentrated in streams or bayous, than in the lower basin where it is spread over the vast areas of marsh and open water (Wax et al. 1978). Sklar (1983) used long-term means to calculate a water budget for the upper part of the basin (Figure 7) and found that of the total annual precipitation, 61 cm was available for surface runoff and groundwater discharge.

Hurricanes and tropical storms with their high winds and heavy precipitation occasionally impinge upon the Louisiana coast, usually between June and November. Such storms can cause severe flooding as well as drastic alterations of normal hydrologic regimes in the basin (Day et al. 1977).

Mean annual temperature is 20.6 °C and varies seasonally from a mean monthly temperature of 13.0 °C in January to 27.5 °C in July. Occasional freezes occur in the basin during the coldest nights, but thawing occurs fairly rapidly after daybreak.

### 2.3 WATER LEVEL VARIATIONS

#### 2.3.1 Tides

Tides in the Barataria Basin are generally diurnal and small. Mean tidal range at the coast (Bayou Rigaud) for 1951-70 was 32 cm, resulting

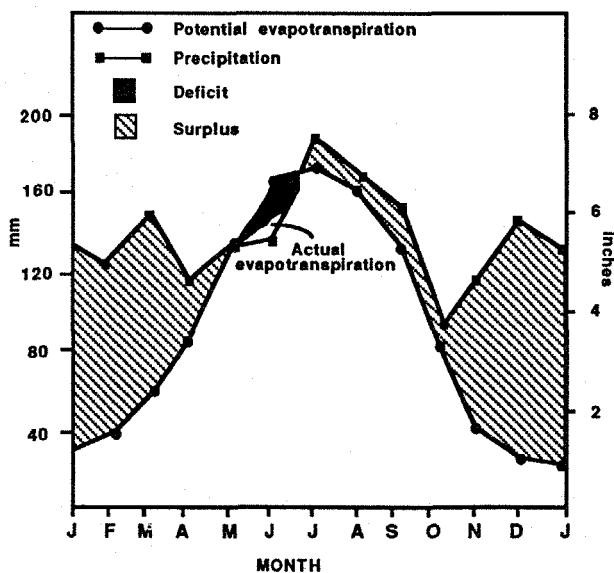


Figure 7. Average water budget for the upper Barataria Basin, 1914-78 (Sklar 1983).

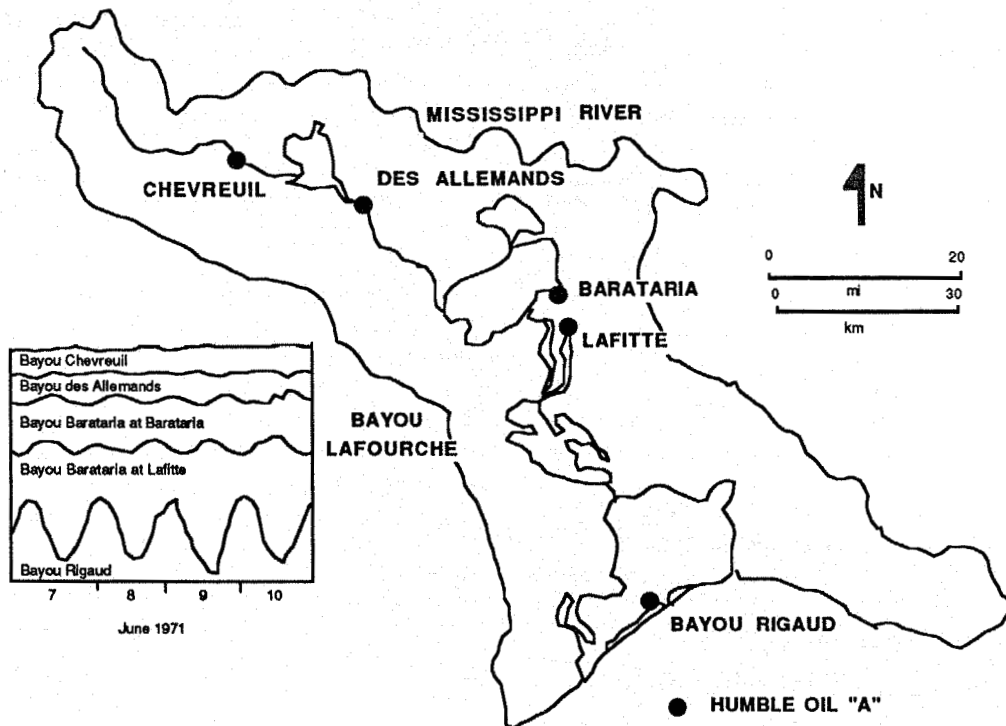
in an estimated average gross turnover of lower Barataria Bay of 30% per tidal cycle (Marmor 1948). The tidal amplitude at Bayou Rigaud is attenuated by 68% at Lafitte, 78% at Barataria, and 90% at des Allemands (Figure 8; Byrne et al. 1976). Tidal range at Bayou Chevreuil is normally less than the accuracy limits of the water-level recorder (about 1.5 cm).

Compared with a semidiurnal tide, a diurnal tide implies a lower frequency in inundation, longer turnover time, and a smaller volume of water available for material transport. Diurnal tides respond differently from semidiurnal tides to changes in the relative positions of the earth, moon, and sun.

In light of the expected differences in response, it is useful to indicate the relative degree of the diurnal nature of the tide. The ratio of the two principal semidiurnal components provides a simple classification of tidal type. According to work by Van der Stock (1897), and modified by Courtier (1938), a ratio of 0.25 or less is indicative of semidiurnal tides whereas a ratio of 3.00 or greater is characteristic of a diurnal tide. Values within a range of 0.25 to 3.00 provide a relative indication of the degree to which the tide is mixed. At Bayou Rigaud, the ratio is equivalent to 10.67 (Marmor 1954) indicating a diurnal dominance.

Three tidal range cycles--biweekly, seasonal, and 18.6 years--affect the inundation regime in the Barataria Basin. Periods of increasing tidal range result in greater frequency and depth of inundation. The effects diminish inland, corresponding with the overall decreasing importance of the tide. The following description of the tidal range cycles is based on information from the coastal station at Bayou Rigaud (Figure 8).

Although there is a slight difference in periodicity, equatorial and tropic tides are basically the diurnal analog to spring and neap tides. The biweekly change in diurnal tidal range is dominated by the changing declination of the moon with respect to the earth's ecliptic (approximately five degrees north and south), rather than the changing phase of the moon. During maximum semimonthly declination, tidal range is at its maximum (tropic tides). When the moon is aligned with the earth's equator, diurnal tidal range is at a minimum (equatorial tides). This latter period also

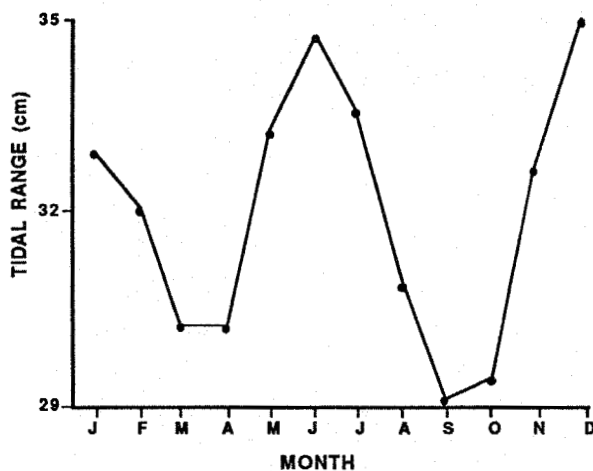


**Figure 8.** Tidal amplitude for five stations in the Barataria Basin. The location for Humble Oil "A" is shown because there is some discussion of this station in the text (modified from Byrne et al. 1976).

represents the time when mixed or semidiurnal tides may be present in the basin.

a. Biweekly tidal range cycle. The variation between equatorial and tropic tides represents the greatest magnitude in range of the tide in the Barataria Basin. This is apparently true for all areas dominated by diurnal tides (Grace 1932; Marmer 1954). During 1971, peak tropic tidal range averaged 45 % above, and peak equatorial tidal range averaged 45 % below, mean tidal range at Bayou Rigaud.

b. Seasonal tidal range cycle. Maximum tidal range occurs during the summer and winter solstices, and minimum tidal range occurs during the spring and fall equinoxes (Figure 9). The maximum seasonal variation occurs from September to December, the difference at Bayou



**Figure 9.** Mean seasonal variation in tidal range at Bayou Rigaud (Baumann 1980).



Rigaud being 6 cm, or  $\pm 10\%$  of mean annual tidal range. The seasonal changes in tidal range modify the effects of the seasonal water level cycle on frequency of inundation (see Seasonal Inundation of Estuarine Wetlands).

c. The 18.6-year tidal range cycle. The variation in tidal range at Bayou Rigaud due to the 18.6-year cycle (Figure 10) is approximately 10 cm, or  $\pm 16\%$  deviation from the long-term mean. This is somewhat greater than the seasonal change in tidal range ( $\pm 10\%$ ) and considerably less than the biweekly change ( $\pm 45\%$ ). Inundation frequency is positively related to the 18.6-year cycle (Figure 10), whereas there is no apparent relationship with duration (percent time). The latter is related more to the change in mean water level from year-to-year.

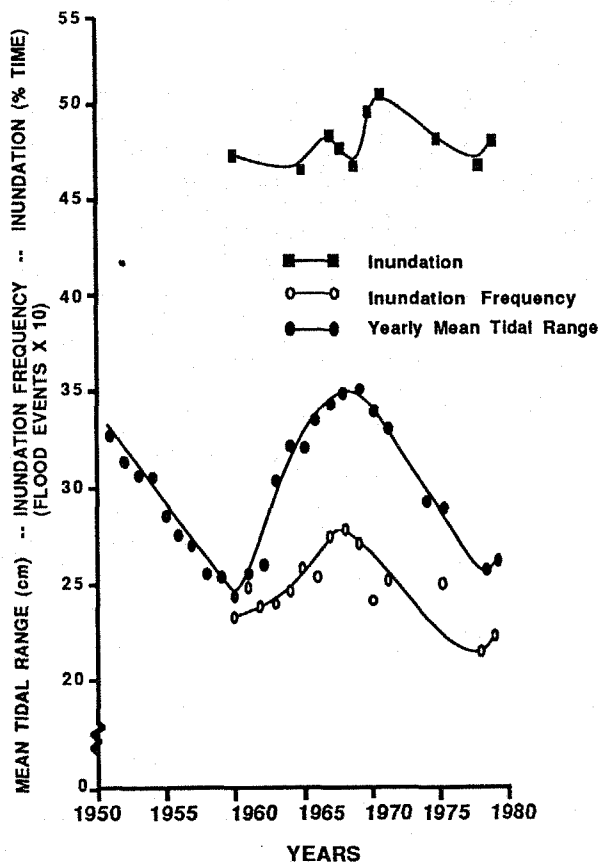


Figure 10. Variation in yearly range of tide at Bayou Rigaud and its effects on inundation of the saline marsh (Baumann 1980).

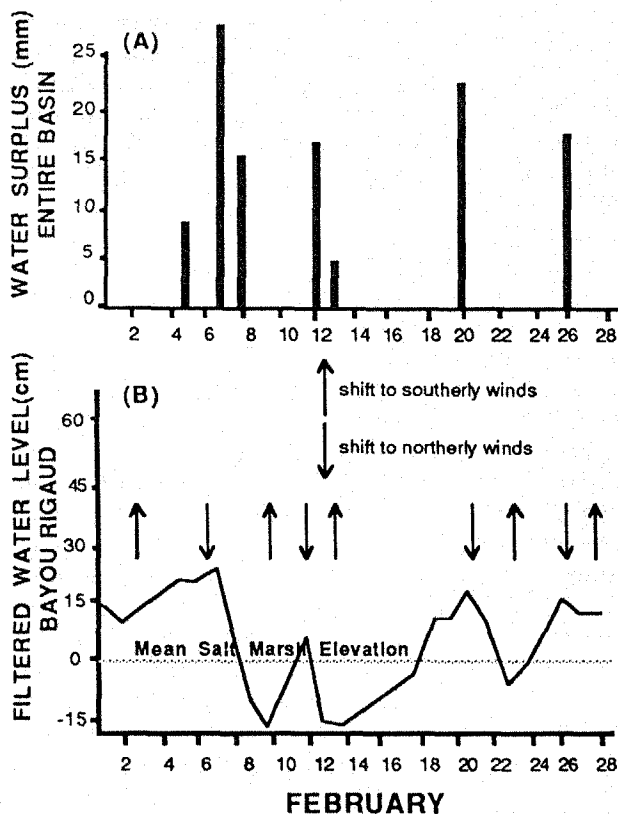
The gradual change in tidal range throughout this period is due to the change in the inclination of the moon's orbit to the earth's equator. During maximum inclination, diurnal tides exhibit maximum range. Semidiurnal tides exhibit an opposite and lesser magnitude response (Marmer 1954).

### 2.3.2 Nontidal Water Level Variations

Meteorological processes are another important mechanism controlling water level variation and flux in the Barataria Basin. The small tidal range increases the relative importance of such meteorological variables as wind stress and atmospheric pressure. Physical parameters that characterize the weather and, in the longer term, climate influence short- and long-term hydrologic responses. Significant increases in wind stress, lasting less than an hour and occurring approximately once every three days during the summer, minimize vertical stratification in the shallow lakes and bays (Hopkinson et al. 1985). At the other temporal extreme, a gradual change or long-term fluctuation in global climate has resulted in an eustatic rise in sea level.

### 2.3.3 Short-Term Impact of Weather Events

Water level variations within one to several days are governed by the combined effects of the change in the diurnal tide and climatic factors such as wind and precipitation. Wind stress is clearly the dominant factor in water level response to changing weather conditions at Bayou Rigaud, with precipitation (expressed as surplus) having little or no effect (Wax 1977). Water levels decrease significantly following a midlatitude cold front passage (Figure 11). The mean water level decrease at Bayou Rigaud, resulting from northerly winds, was 15 cm during one year of observation, and decreases of over 40 cm are not unusual (Wax 1977). The magnitude of the response of the water level to frontal passages and the frequency of this event during winter (5.7/mo) create an important mechanism for material transport in this low tidal energy environment. As a cold front approaches the area, southerly winds increase in speed, resulting in water set-up in the estuary (Figure 11). The relatively strong winds resuspend shallow bay bottom sediments, resulting in a seasonal peak in turbidity levels (Cruz-Orozco 1971) and net deposition of sediment as winds abruptly shift from the north, creating decreased



**Figure 11.** Water level and water surplus (excess precipitation) in the lower Barataria Basin during February 1971. Tidal pulses have been filtered out of the water level data (modified from Wax et al. 1978).

water levels (Figure 11) and strong ebb flows, which aid in the transport of particles from the marshes to the open bays and gulf (Happ et al. 1977). Water levels usually increase during all other weather events because of the dominance of southerly winds, although the response to tropical disturbances is variable (Wax 1977). Steady-state conditions of water level are generally achieved within 24 hrs regardless of the duration of the weather event, with the noteworthy exception of gulf tropical disturbances.

In the upper basin, the responses of water level to wind stress are similar to those at Bayou Rigaud. In cases where surplus rainfall is generated, water level response upstream in Bayou Chevreuil, unlike Bayou Rigaud, is initially independent of wind stress. Despite northerly winds, water levels typically rise at Bayou Chevreuil after the passage of a cold front because of

accompanying rains. Wax (1977) attributes Bayou Chevreuil's disparate (in comparison to nine Louisiana coastal stations) response to the altered hydrology of the upper basin. Numerous agricultural drainage and oil access canals facilitate rapid upland runoff into Bayou Chevreuil. Spoil embankments paralleling the canals retard overland sheet flow and alter the storage and release of flood waters. In essence, water level change at Bayou Chevreuil during periods of surplus rain is characterized by an abrupt rise (aided by canals) followed by a slow fall (release from semi-impoundments), a pattern similar to that of upland streams (Wax 1977).

In summary, wind stress results in a short-term water level response of a few hours throughout the basin. Water level responses to precipitation are very minor at the coast but increase substantially in the upper basin.

#### 2.3.4 Seasonal Water Level Variation

A bimodal distribution of seasonal water level is fairly consistent throughout the basin (Figure 12); Marmer (1954) has shown this to be true throughout the northern Gulf of Mexico. Annually at all stations there is considerable variation in the magnitude of water level and in the months in which the maximas and minimas occur, but the bimodal distribution occurs with a high degree of regularity from year to year. Within the basin, there is a conspicuous increase in the spring maximum in an inland direction (Figure 12). This trend probably reflects increasing upland runoff influence as opposed to marine dominance at the coast (Wax 1977). No streamflow data are available for the area, but a long-term water budget for the upper Barataria Basin indicates that there is normally considerable surplus water generated for streamflow during this period (Figure 7).

Seasonal water level variation along the northern gulf coast is climatic in origin (Marmer 1954). Seasonal water level changes at high latitudes are primarily a result of barometric pressure changes, while at low latitudes, seasonal water level variations are largely changes in volume in response to seasonal heating and cooling of the water (Lisitzin and Pattullo 1961). Chew (1962) noted that the dominant feature of water level changes along the northern coast of the Gulf of Mexico is the semiannual rise and fall of sea level. Seasonal warming and cooling results in a

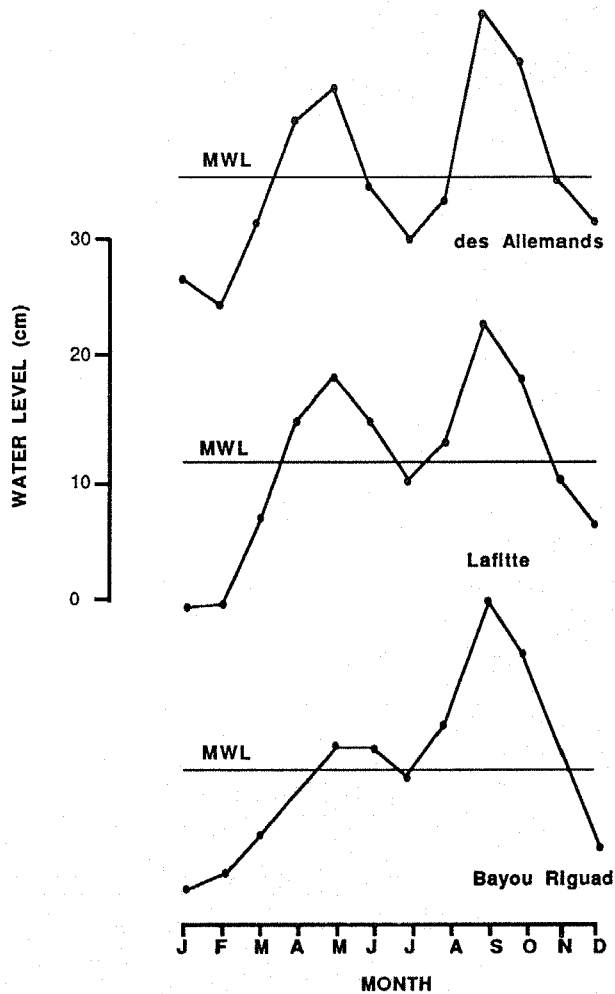


Figure 12. Mean seasonal water level for selected stations in the Barataria Basin (Baumann 1980).

maximum expansion and contraction of nearshore waters in September-October and January-February, respectively (Chew 1962; Whittaker 1971; Sturges and Blaha 1976). The secondary maximum in spring and secondary minimum in midsummer have been attributed to seasonal shifts in the wind regime over the Gulf of Mexico, resulting in alternating onshore and offshore transport of water (Chew 1962). The substantial difference from low wind stress in summer to higher values in fall accentuates the corresponding rise in water level, and the reversal in direction of high wind stress from fall to winter accentuates the corresponding decrease in water level (Sturges and Blaha 1976). Spring and fall correspond with maximum east and southeast

winds (Chew 1962), and an onshore transport of water results in a relaxation of an offshore gyre called the Mexican Current (Sturges and Blaha 1976). Winter and summer correspond with maximum westerly winds (southwest in summer, northwest in winter), which strengthen the Mexican Current, causing an offshore transport of water (Sturges and Blaha 1976).

Other factors that may contribute to the seasonal variability of water levels include barometric pressure and river and groundwater discharge and recharge. At New Orleans, the 30-year mean monthly range of barometric pressure is 6 mb. High barometric pressure during winter and low barometric pressure during fall inversely correspond with the seasonal water level cycle at Bayou Rigaud as shown in Figure 12. Several investigations have shown that water level decreases nearly 1 cm for each 1 mb increase in barometric pressure (e.g., Lisitzin and Pattullo 1961). Thus, the expected mean seasonal range in water level as a response to barometric pressure is approximately 6 cm, or 25% of the total mean seasonal water level change at Bayou Rigaud.

The proximity of the lower Barataria Basin to the mouth of the Mississippi River would seemingly have an effect on local water levels. Meade and Emery (1971) have shown that river discharge has a significant effect on year-to-year water level variability in the Gulf of Mexico. The seasonal relationship, however, does not appear to be strong. The spring rise in water level is somewhat out of phase with Mississippi River discharge, but this could be attributed to a lag factor. The more inland stations within the basin indicate that local streamflow and runoff has a greater effect on water levels within the basin than does Mississippi River flow.

The effects of groundwater discharge on estuarine and coastal water levels are unknown, but they are assumed to be minor. Groundwater discharge is probably fairly constant with no major fluctuations that could contribute to water level change.

### 2.3.5 Seasonal Inundation of Estuarine Wetlands

The duration of seasonal inundation of wetlands in both the upper and lower ends of the Barataria Basin (Figure 13) is largely a function of the seasonal water level cycle (Figure 12). A

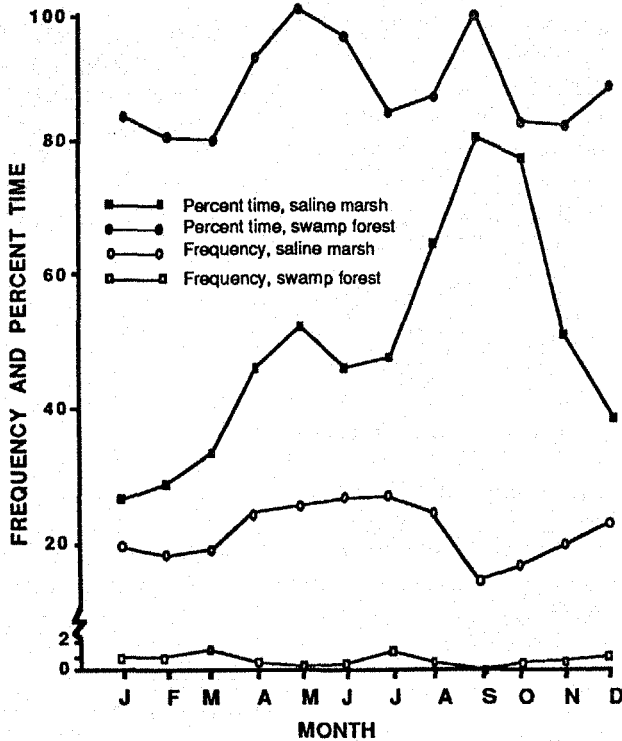


Figure 13. Comparison of the seasonal inundation regimes of the saline marsh and swamp forest, 5-year mean (Baumann 1980).

comparison of flooding duration (percent time) in the saline marsh with that in the swamp forest indicates that the duration of flooding increases as a function of distance inland from the coast (Figure 13). Annually, the saline marsh is inundated some 50% of the time, whereas the swamp forest is inundated in excess of 80% of the time.

The frequency of flooding is less variable seasonally than the duration of flooding, and frequency of flooding decreases inland (Figure 13). At the upper end of the Barataria Basin, in the swamp forest, there is no definitive seasonal pattern of frequency of inundation. The swamp forest is typically flooded for weeks at a time. On a mean annual basis, the swamp forest is flooded only ten times, but cumulatively these flood events represent 323 days/yr. This long-term flooding can present problems for the trees (see Chapter 4). In the saline marsh, the frequency of inundation is a function of the seasonal changes in water level due to tidal range and the sequences and aspects of weather events.

The relatively constant numbers of flooding events in the marsh over the year (average of 20/month) result from the additive, but out of phase, effects of tidal and weather-related factors. The seasonal change in tidal range (Figure 9) is out of phase with the seasonal water-level cycle (Figure 12). When water level is at a maximum in September, for example, tidal range is at a minimum, resulting in deep flooding of marshes for long periods of time. Thus, the seasonal low in frequency of flooding in September (approximately 15 events, Figure 13) is the result of high ambient water levels above the marsh surface.

On the other hand, frequency of flooding in the saline marsh during December (a mean of 23.4 events) is somewhat higher than the mean monthly rate (21.9 events), although water levels are below average (Figure 12). Two factors help to explain the increase in flooding frequency from September to December, despite a 21-cm fall in mean monthly water level at Bayou Rigaud. First, tidal range is at a semiannual maximum during December and represents a 6 cm (19%) increase from the September minimum (Figure 9). Secondly, a seasonal change in the sequence of weather events helps to maintain both frequency and depth of inundation. During December and throughout the winter, winds are directionally more variable than during the other seasons, because of the higher frequency and greater intensity of midlatitude cold front passages (Wax et al. 1978). With the passage of a cold front, winds are northerly, resulting in water levels that fall below the marsh surface (Figure 11). As the next frontal passage approaches from the northwest, winds shift at the coast to southerly components. The continued approach of the front increases the strength of southerly winds that elevate water levels above the marsh surface (Figure 11). When the front arrives, the cycle is initiated once again. Thus, the combination of maximum tidal range and the passage of cold fronts results in salt marsh flooding during December that is frequent but of short duration.

Frequency of inundation in the saline marsh reaches a secondary minimum from January through March following the secondary maximum in December (Figure 13) because of the continued fall in mean monthly water level (Figure 12) partly due to steric effects and a decrease in tidal range (Figure 9). The abrupt rise in water level in April

caused by shifting winds results in more frequent flooding despite the concurrent secondary minimum in tidal range. The seasonal cycle is completed with a high flooding frequency maintained through the summer because of increasing tidal range. Climate has less influence on frequency of inundation in summer than in winter. Winds are generally less intense and are directionally less variable during summer than in winter. Tropical weather types dominate in summer; creating a dominance of southerly winds. A synoptic analysis of southeast Louisiana for 1971 (Muller 1977) indicated that tropical weather events occurred 98% of the time in June, 88% in July, and 67% in August. Because the wind regime is less variable both in terms of direction and velocity in summer than in winter, steady-state conditions are approached more frequently in summer and total water flux is correspondingly less.

In summary, water level variation in the Barataria Basin is governed by the combined effects of tides and weather events. Because tidal range is small, climatic events assume great importance. Wind regimes are directionally more variable and generally of greater intensity during winter. Thus, during winter, steady-state conditions are achieved less frequently and total water flux is greater.

### 2.3.6 Seasonal Salinity

The long-term mean salinity regime at the coast (Grand Terre) is characterized by a spring low followed by a rise peaking during early winter (Figure 14). Progressing inland, the seasonal salinity pattern becomes bimodal, with higher salinities occurring during spring and fall (Figures 14 and 15). These seasonal patterns and their spatial variability can be largely attributed to three factors: seasonal precipitation and evapotranspiration regime, Mississippi River discharge, and the seasonal water level cycle.

Rainfall is uniformly distributed throughout the year, on a monthly mean basis, with the noteworthy exception of a somewhat drier fall (Figure 7). Based only on precipitation and evapotranspiration, higher salinities should occur in summer and fall.

Mississippi River discharge may modify the timing of seasonal salinity patterns. The spring

decrease in salinity at Grand Terre is of greater magnitude and occurs later than that of the inland stations. Perret et al. (1971) attribute this to Grand Terre's proximity to the Mississippi River Delta, in

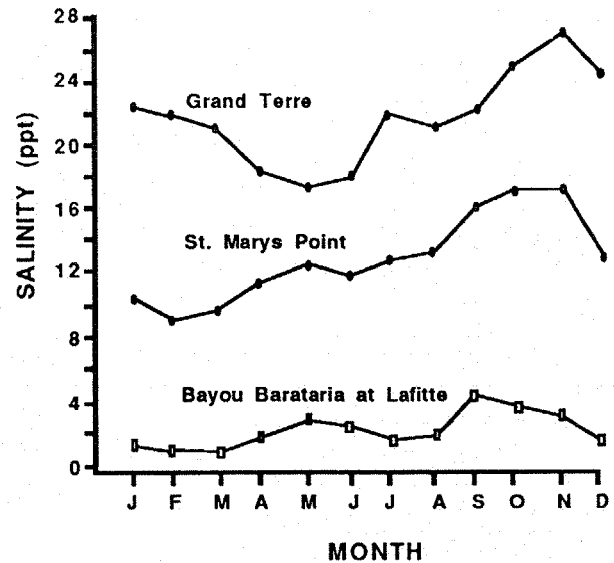


Figure 14. Long-term averaged monthly means of salinity, 1961-74 (Byrne et al. 1976).

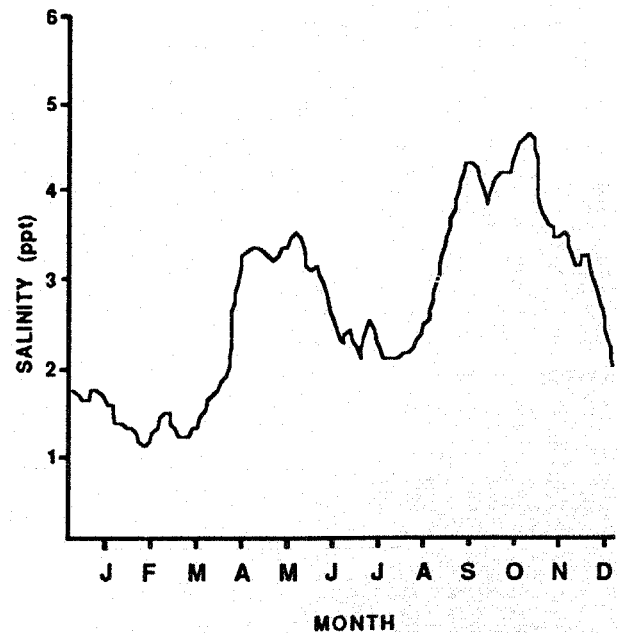


Figure 15. Mean weekly salinity at Lafitte, 1961-74. Data are the same as in Figure 14, but the salinity scale has been enlarged (modified from Byrne et al. 1976).

which maximum discharge occurs, on the average, one to two months later than local runoff.

Another apparently important but never substantiated factor in the seasonal salinity regime of the Barataria basin is the role of the seasonal water-level cycle (Figure 12). At Lafitte the two patterns closely resemble one another (Figures 12, 14, 15). There the abrupt decrease in salinity from early November to December is enhanced by a change in the wind regime, in addition to increased precipitation and decreased evapotranspiration. The increase in northerly wind components from fall to winter results in a seasonal net flow of water from estuary to gulf and a corresponding movement of fresh water from the upper to the lower basin. The abrupt rise in salinity at Lafitte in mid spring corresponds with a seasonal rise in water level (with waters flowing in from the gulf), as well as an increase in evapotranspiration rates. Despite high evapotranspiration rates during summer and low surplus rainfall, salinity falls to a secondary summer minimum at Lafitte. As in the winter, the secondary seasonal low salinity level corresponds with secondary seasonal low water level. Fresh water stored in the upper basin during winter and spring moves down the basin in response to the net outflow from the estuary.

### 2.3.7 Long-Term Water Level Variation

The one known long-term trend of water level is the apparent rise in sea level (Figure 16). The trends depicted in Figure 16 reflect the combined effects of subsidence and eustatic sea level rise. Global eustatic sea level rise has been estimated to account for about 0.14 cm/yr (Bloom 1977; Gornitz et al. 1982), a value in close agreement with tide gauge data from the relatively stable west Florida coast (Hicks 1981).

Subsidence is much more important. There was a significant, and as of yet unexplained, increase in the subsidence rate from 0.27 cm/yr during 1948-59 to 1.29 cm/yr for 1959-71 at Bayou Rigaud (Swanson and Thurlow 1973). The total apparent sea level rise for 1959-79 was 1.23 cm/yr at Bayou Rigaud (Baumann 1980). Differentiation between eustatic sea level rise and subsidence is functionally unimportant as they both have the same effect--the water appears to rise with respect to the land.

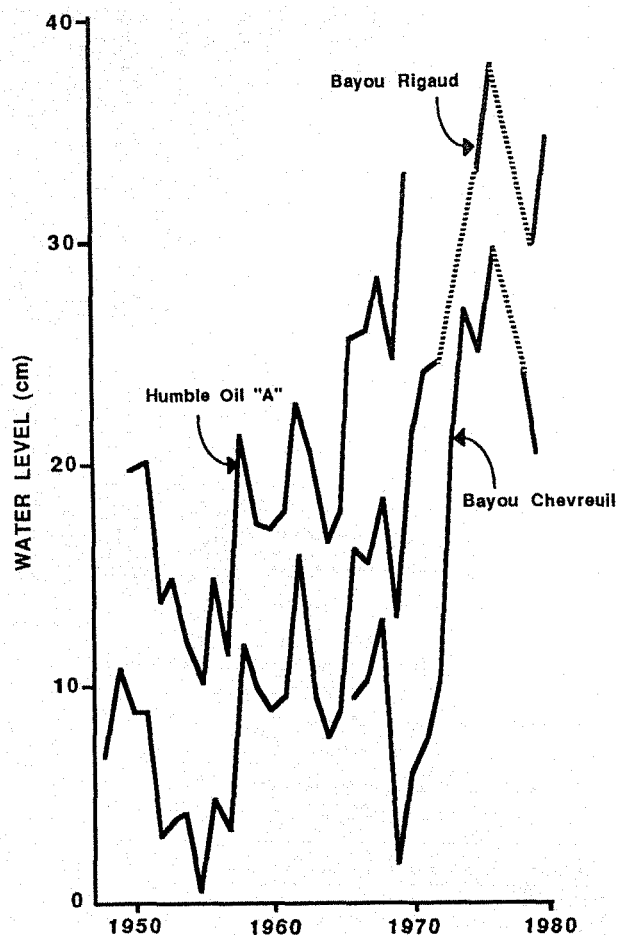


Figure 16. Variation in yearly mean water level at selected stations. Dashed lines indicate that an annual mean could not be determined for those periods (Baumann 1980).

Aberrations in the trend of sea level rise (Figure 16) have not received much attention and are typically attributed to climatic variability. One noteworthy exception is the work of Meade and Emery (1971), who showed that 21% of the year-to-year variation in water levels over the past several decades in the gulf is caused by river runoff.

## 2.4 SEDIMENTATION

Unless there are compensating factors, sea level rise could result in the die-off of emergent macrophytes. Known sedimentation rates on Barataria marshes are provided in Table 2. Streamside marshes are, in general, keeping pace with apparent sea level rise but streamside

Table 2. Mean annual sedimentation rates in various wetland environments in the Barataria Basin.

Marsh type	Method	Period	Mean annual sedimentation rate (cm)		Reference
			Streamside	Inland	
Fresh	RD <sup>a</sup>	1963-80	1.06	0.65	Hatton 1981
Intermediate	RD	1963-80	1.35	0.64	Hatton 1981
Brackish	RD	1963-80	1.40	0.59	Hatton 1981
Saline	RD	1963-77	1.35	0.75	DeLaune et al. 1978
Saline	VM <sup>b</sup>	1975-79	1.52	0.91	Baumann 1980

<sup>a</sup>Radiometric dating with <sup>137</sup>Cs.  
<sup>b</sup>Visual marker -- white clay.

marshes only represent a maximum of 25% of the wetland area in brackish and saline marshes and typically less than 5% in fresh marshes. The inland marshes that represent the bulk of the marsh area are not keeping pace, which is a contributing factor in the loss of 40,000 ha/yr of coastal wetlands in Louisiana (Gagliano 1981). The problems of sediment deficiency and wetland loss are the result of complex interactions between natural processes and man's modification of those processes.

Historically, the bulk of mineral sediments transported to and deposited on the marsh surface occurred during flood episodes of the Mississippi River with peak flows typically occurring between March and April. A 5-year study examining the seasonality of sedimentation in the lower Barataria Basin (Baumann et al. 1984) concluded that sediment input from the Mississippi River is no longer a viable process. Vertical accretion of the marsh is now largely a storm-related phenomena with sediments from other eroding marshes and bay bottoms being deposited.

## 2.5 HUMAN PERTURBATIONS

The change in the sedimentation regime of the salt marsh of the Barataria basin is a dramatic example of human intervention in natural

processes. Before the completion of the artificial levee system following the 1927 flood, riverine sediments were deposited in the Barataria Basin by overbank flow and crevasse formation. Thus, sedimentation primarily occurred during the spring floods of the Mississippi River. During the present deterioration phase of the basin, sedimentation of the salt marsh occurs primarily during winter storm and hurricane conditions (Baumann 1980). These latter processes are not sufficient to maintain the elevation of the marsh with respect to the sea. The wetland loss problem is intensified by other human activities, e.g., canals (Craig et al. 1979), and if the trend continues, the present salt marsh will be converted to openwater within the next several decades.

Canals and the spoil banks that frequently accompany them contribute to land loss directly by their creation, and indirectly by their alteration of natural flow. Spoil banks retard the exchange of water, sediments, nutrients, and other materials between the marsh and open water areas. Canals accelerate both the intrusion of salt water and runoff of fresh water. Northern Barataria Bay has experienced a significant annual increase in salinity of 0.108 ppt from 1961-74 (Van Sickle et al. 1976). Ultimately, the entire basin is expected to become an open-water brackish bay or sound unless Mississippi River flow is reintroduced to the area.

## CHAPTER 3

### CHEMISTRY AND NUTRIENT DYNAMICS

by

C. J. Madden and R. D. DeLaune

#### 3.1 INTRODUCTION

Nutrient dynamics in Barataria Basin are controlled by the amount of allochthonous materials entering the basin, hydrology, and biological and chemical processes acting within the basin. The hydrologic flow from the upper basin to the Gulf of Mexico carries nutrients entering from the heavily populated uplands surrounding the upper basin to the upper, middle, and lower basins. The nutrients undergo a series of transformations as they move through the basin.

Upper Barataria Basin is composed of fresh swamp forest, marsh, and lake. Around the upland perimeter, increasing urban, agricultural, and industrial pollution has introduced nutrient-rich runoff to the basin. The middle basin grades into brackish marsh surrounding a complex of lakes which act as receiving basins for upland and upper basin runoff. In lower Barataria Basin, two large saline bays, Barataria Bay, and Caminada Bay, which open into the Gulf of Mexico, are bordered by tidal salt marshes. The distinct upper, middle, and lower basin habitats of Barataria Basin are distinguished by their salinity and nutrient regimes and by the amount of production they sustain.

Historically, regular inundation of the basin by floodwaters topping the natural levees introduced riverine water and nutrients to the swamp and marsh. As cultural development occurred along the river and basin, artificial levees were constructed, eliminating all riverine input to the basin. Today, the sole hydrologic input is precipitation, which averages 160 cm/yr (Sklar 1983). Nevertheless, the hydrologic transport of sediments and nutrients remains the major mechanism of nutrient supply in the Barataria

system. Fertilizer and dead organic material which accumulate in the uplands during the summer months are flushed through the basin during the fall in freshwater pulses. Biological processes allow nutrient exchange among atmosphere, biosphere, and sediments and also make nutrients available for hydrologic transport. A number of biological processes important to nutrient dynamics have been studied in the basin and will be discussed. These include nitrogen fixation, nitrification, denitrification, ammonification, photosynthesis, respiration, and mineralization.

Salinity fluctuations are important in determining the chemical properties of the water as well as the distribution of biota in the wetlands. By monitoring the conservative property of salinity, investigators have traced long-term changes in hydrologic inputs and flows through the basin. The seasonal salinity regime of Barataria Basin is a complex one controlled by precipitation, winds, and the proportion of Mississippi River and gulf water imported through the bay mouths. Strong northwest frontal passages drive water from the upper basin to the gulf, freshening the entire basin during winter. At this time of year, the gulf water level is at its lowest, assisting the southward flow. In summer, predominantly southeasterly winds and a high gulf water level push salt water into Barataria Basin from the gulf. High evapotranspiration:precipitation (ET:P) ratios coupled with the gulf backpressure generally cause freshwater flow downbasin to cease in July and August, raising basin salinity. Precipitation in autumn exceeds evapotranspiration and freshwater again feeds the lower basin.

The upper basin swamp forest never experiences salinity. Middle basin salinities range



between 0 and 5 ppt depending on precipitation and the amount of gulf water driven inland by southeasterly winds. The lower basin-bay area experiences salinities of 18-30 ppt throughout the year. Studies have shown salinity in the middle basin to be increasing by almost 0.11 ppt/yr (Van Sickle et al. 1976). At the turn of the century, the middle basin was fresh. Encroachment by saline water has increased middle basin salinity to 5 ppt. Toward the gulf, salinity in upper Barataria Bay has increased to 11 ppt where 75 years ago it was only 6 ppt. Predictive models indicate that overall salinity will increase about 30% by the year 2000 (Van Sickle et al. 1976).

Increases in salinity are directly and indirectly related to human activity. The construction of artificial levees has stopped the inflow of fresh river water to the basin. The dredging of linear canals has given saline gulf water direct access far upbasin (Craig and Day 1977). Marsh subsidence has converted much of the marsh area to open water, allowing saltwater intrusion. Natural subsidence is a consequence of sediment consolidation and eustatic sea level rise. The indiscriminate dredging of canals and construction of artificial levees that block the influx of important marsh-building sediments from the river has unnaturally increased land loss rates to more than 100 km<sup>2</sup>/yr (Gagliano et al. 1981).

Salinity increases are also affecting the production of marsh macrophytes within the basin. Recent studies (Pezeshki et al. in press) show that salinity increases currently occurring in brackish marshes are altering normal physiological functions of *Spartina patens*, the dominant species in the Barataria brackish marshes. Reduction in primary production of marsh macrophytes will affect estuarine carbon cycling and organic carbon pools which are important to vertical marsh accretion. Organic carbon accumulation is important in maintaining marsh elevations in rapidly subsiding environments such as the Barataria Basin.

### 3.2 UPPER BASIN NUTRIENT PROFILE AND TROPHIC STATE

The upper Barataria Basin is dominated by swamp forests of baldcypress and water tupelo and, in better drained areas, by bottomland hardwoods. Lac des Allemands, the major water body in this section, is always fresh and serves as

the catchment for all upper basin drainage. It is fed by upland runoff through Bayou Chevreuil and Grand Bayou. Fresh marsh borders the lake to the south and east.

The natural chemistry of the upper basin has been disturbed by urban and agricultural activity on the surrounding natural levees. The development of population centers has introduced high levels of nutrients and sediments into upland runoff. Impervious urban land areas and highly channelled drainage networks in farm fields have increased upland runoff volumes and changed the natural hydrology of the upper basin. These impacts are compounded by canalization of the swamp and marsh by oil and gas interests. In short, the burgeoning development of the area is increasing nutrient input and reducing the capacity of the wetlands to process these inputs. The result is eutrophication of the basin's waters, a disturbed swamp system chemistry, and reduced swamp productivity (Day et al. 1982).

Annual loadings of 1.2 million kg nitrogen (N) and 130,000 kg phosphorus (P) are estimated to enter the upper basin from all upland sources (Kemp 1978). Runoff from agricultural land adds more N and P per area than any other land use, comprising an estimated 75% of all N and 95% of P entering the basin. Seventy-one percent of the upland Barataria watershed is now devoted to agriculture (Hopkinson 1978) and cropland erosion accounts for over 80% of the 63 million kg or 63,000 metric tons of sediment lost annually from the watershed. Based on predictions of land use, N loads are expected to increase by 28% and P loads by 16% before 1995 (Hopkinson and Day 1980b).

As a means of quantitatively assessing the water quality of Barataria Basin, Seaton and Day (1979) modified a statistical technique developed by Brezonik and Shannon (1971) which yields an index of the degree of eutrophication in a water body. The Trophic State Index (TSI) ranks bodies of water based on a multivariate statistical formulation including total N, total P, secchi depth, and chlorophyll *a* data (Table 3). By ranking all water bodies in Barataria Basin from most negative TSI (oligotrophic) to most positive (hypereutrophic) it was shown that all waterways in the upper basin clustered together in the eutrophic to hypereutrophic range. Poor water quality characterized by high nutrient levels, high algal

**Table 3.** Average yearly nutrient and chlorophyll *a* concentrations and secchi depths at several sites in Barataria Basin. GIWW = Gulf Intracoastal Waterway. Nutrient data are in mg/l; chlorophyll data in mg/m<sup>3</sup> and secchi in cm.<sup>a</sup>

Area/Location	NH <sub>4</sub> <sup>+</sup>	NO <sub>3</sub> <sup>-</sup>	Inorg N	PO <sub>4</sub> <sup>-3</sup>	TON	TP	Secchi	CHL <i>a</i>
Upper/swamp	0.13	0.08	0.21		1.17	0.22	50	2
Upper/St. James Canal	0.10	1.88	1.98		2.01	0.19	8	53
Middle/Lake Salvador	0.09	0.11	0.20		0.73	0.11	46	3
Middle/Lake Salvador <sup>b</sup>	0.06	0.95	1.01	0.06			53	8
Middle/Lake Cataouatche	0.06	0.27	0.33		1.59	0.15	32	27
Middle/Lake Cataouatche <sup>b</sup>	0.08	0.15	0.23	0.09			53	47
Lower/GIWW	0.10	0.48	0.58		0.95	0.89	11	7
Lower/Little Lake	0.15	0.12	0.27		0.71	0.07	65	5
Lower/Little Lake <sup>b</sup>	0.10	0.21	0.31	0.06			54	10
Lower/Airplane Lake <sup>c</sup>			0.06	0.04				

<sup>a</sup> Data from Seaton and Day (1979) unless otherwise noted.

<sup>b</sup> From Hopkinson and Day (1979)

<sup>c</sup> From Ho and Lane (1973)

standing crop, and low water clarity persisted throughout the upper basin. Downbasin, waters gradually improved in quality. Caminada and Barataria Bays had negative TSI, indicating mesotrophy to meso-oligotrophy (Table 4).

### 3.2.1 Drainage Density and Trophic State

Oil access canals and agricultural drainage ditches cutting through the basin (Figure 17) have been cited as having exacerbated the problem of nutrient enrichment. In the swamp's natural condition, before the dredging of linear canals, runoff was distributed as sheet flow over the swamp forest. Now, hydraulically efficient canals guide water and nutrients directly to receiving waterbodies, bypassing the swamp forest. Studies have shown that the Barataria swamps had been acting as effective nutrient filters, removing inorganic nutrients from percolating floodwaters (Meo et al. 1975; Kemp 1978). But in the current situation, nutrient removal and uptake processes occurring in the canals alone are insufficient to

reduce the runoff nutrient loads, resulting in the high loading to Lac des Allemands (Butler 1975).

By constraining canal flow, spoil banks restrict the natural lateral transport of water necessary for the removal of wastes, the replenishment of marsh sediments, and the import of new nutrients to the swamp forest. Obstruction of overbank flooding by levees can result in nutrient starvation and the blocking of swamp substrate accretion. As the density of canals increases, there is a concomitant reduction in overland flow and basin water storage capacity.

Horton (1945) developed a means of quantifying the impact of canals on wetlands. The Drainage Density Index (DDI) reflects the degree of canal development in a wetland and is defined as the total length of the drainage network per square unit of drainage basin. A total of 37.2 linear mi of canals criss-cross the upper Barataria Basin representing a DDI of 40.0 mi/mi<sup>2</sup> in uplands (Gael and Hopkinson 1979). When upland DDI is

**Table 4.** Trophic state index (TSI) classification of Barataria Basin, Louisiana. LB = lower basin, MB = middle basin, UB = upper basin, O = oligotrophic, M = mesotrophic, E = eutrophic, and H = hypereutrophic (modified from Witzig and Day 1983a, b).

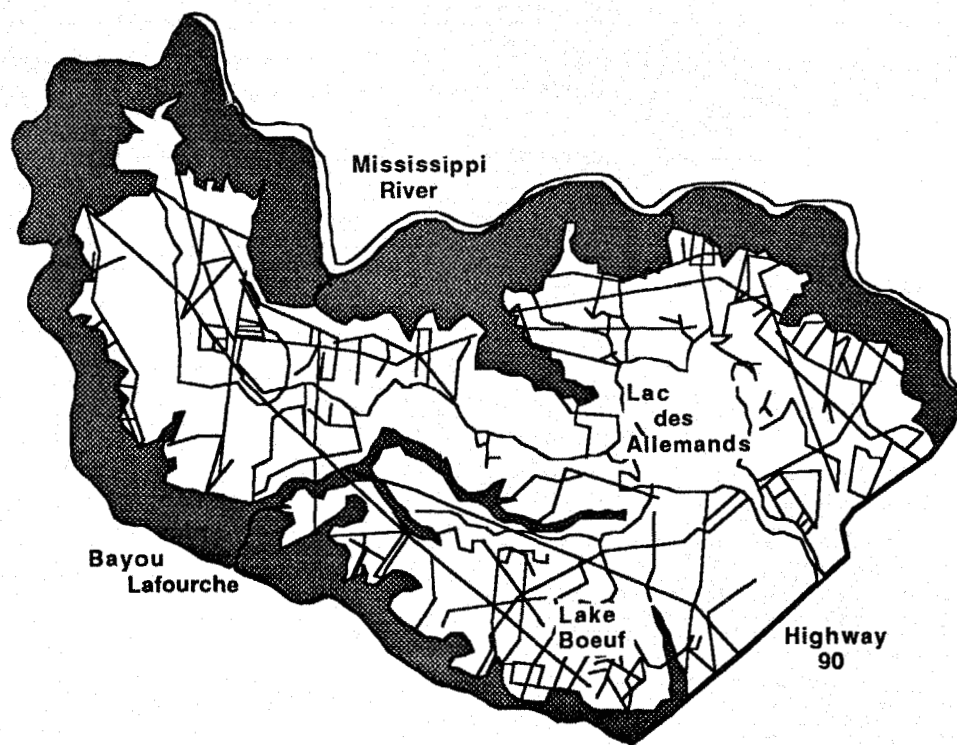
Station	Location	TSI score	Trophic group
Caminada Pass	LB	-4.8	M-O
Bayou Rigolettes	LB	-4.3	M
Barataria Bay	LB	-3.8	M
Lake Salvador	MB	-3.3	M
Bayou Perot	LB	-2.8	M
Little Lake	LB	-2.7	M
Bayou Barataria	LB	-1.8	M
Barataria Waterway	LB	-1.6	M
Natural swamp stream	UB	-1.4	M
John-the-Fool Bayou	LB	-0.6	M
Little Lake oil and gas field	LB	-0.4	M
Bayou Chevreuil 1	UB	6.0	E
Lake Cataouatche	UB	0.7	E
Bayou des Allemands	MB	2.6	E
Burtchell Canal	MB	2.7	E
Bayou Citamon	UB	3.7	E-H
Lac des Allemands	UB	3.8	E-H
Bayou Chevreuil 2	UB	4.0	E-H
St. James Canal	UB	6.4	H

recalculated to include all split and quarter ditches in sugarcane fields, the index rises to 800 mi of canal/mi<sup>2</sup>.

A strong correlation has been noted between drainage canal density and the condition of receiving water bodies. In the Gael and Hopkinson study, Barataria Basin was divided into 24 subcatchment areas, including water quality stations that had been previously sampled by Seaton and Day (1979). Within subcatchments, a direct relationship between DDI and the deterioration of water quality was found indicating that eutrophication in the upper basin is a function of the density of drainage canals. In regions of low canal density, the upper basin is generally oligotrophic to mesotrophic (Craig and Day 1977; Seaton and Day 1979). In regions of extensive channelization and agricultural development, the upper basin has become eutrophic to hypereutrophic. Large percentages of agricultural land included in two of the subcatchments with a

large number of canals contributed to the high total N loads of 2.0-2.2 mg/l. Catchments consisting of underdeveloped natural swamp exhibited good water quality and had lower total N values averaging 0.67 to 1.1 mg/l.

Most of the canal development has occurred in the last two decades. The nutrient-concentrating effect of canals can be illustrated by recalculating loading rates to the swamp as they would have been without the presence of canals and levees. If the 1.2 million kg of N entering the basin from upland sources were allowed to move as sheetflow over the entire upper basin, the annual N load would total about 1.27 g/m<sup>2</sup>, a twenty-fold reduction from current levels of 30.1 g/m<sup>2</sup> to Lac des Allemands. Likewise, the 132,283 kg of P entering from uplands, distributed over the basin floor, would add 0.14 g/m<sup>2</sup> annually, instead of the 4.3 g/m<sup>2</sup> loaded to Lac des Allemands by canal-directed flow (Hopkinson and Day 1980a, b).



**Figure 17.** Drainage network of the upper Barataria Basin. Stippled areas are intensively drained natural levees (modified and used with permission, from Gael and Hopkinson 1979, copyright LSU Division of Continuing Education).

### 3.2.2 Nutrient Uptake, Productivity, and Export

The disruption of basin hydrology by canals and the increasing inputs of pollution have resulted in high nutrient concentrations in water bodies of the upper basin (Stow et al. 1985). However, a number of studies (Seaton and Day 1979; Hopkinson and Day 1979; Kemp 1978; Butler 1975) have shown striking differences between the nutrient levels in impacted lakes and natural swamps in the upper basin. While bayous and lakes receiving large inputs of upland runoff have N:P ratios of 6:1 (Kemp 1978) to 9.2:1 (Gael and Hopkinson 1979), natural swamp waters exhibit ratios of 2:1 (Kemp 1978). Inorganic N is removed from swamp floodwaters through denitrification and the sedimentation of ammonium-bearing clays (Kemp 1978; Engler and Patrick 1974). Although the sedimented clays remain in the system, the end product of denitrification is  $N_2$  gas which is released to the atmosphere.

Ten percent of ammonium inputs to swamps is removed through plant uptake. Another

large percentage is adsorbed to sediments. Swamp sediment pore water ammonium concentrations are 15 times the concentrations in overlying waters (Kemp 1978). In passing through the swamps, water column nitrate levels in bayou inlets are reduced by one-half and N is exported from the swamps largely in organic form, as detritus and leachates. Thus, nitrate concentrations in swamp streams are kept low throughout the year, averaging 0.05 to 0.14 mg/l (Kemp 1978; Butler 1975), while bayou and lake sites always exhibit high concentrations of nitrate (0.28 to 0.32 mg/l). The high levels of nitrate and ammonium found in Bayou Chevreuil and other receiving waters draining the uplands show a seasonality that coincides in spring with peak fertilizer application and peak hydrologic flushing, and in late summer with the decomposition of large blooms of N-fixing algae (Figure 18).

Nitrogen-limited freshwater marshes in the upper basin can improve water quality by removing nutrients from inflowing waters. In one uptake study (DeLaune et al. 1986), eight percent of the labelled N applied to the freshwater marshes

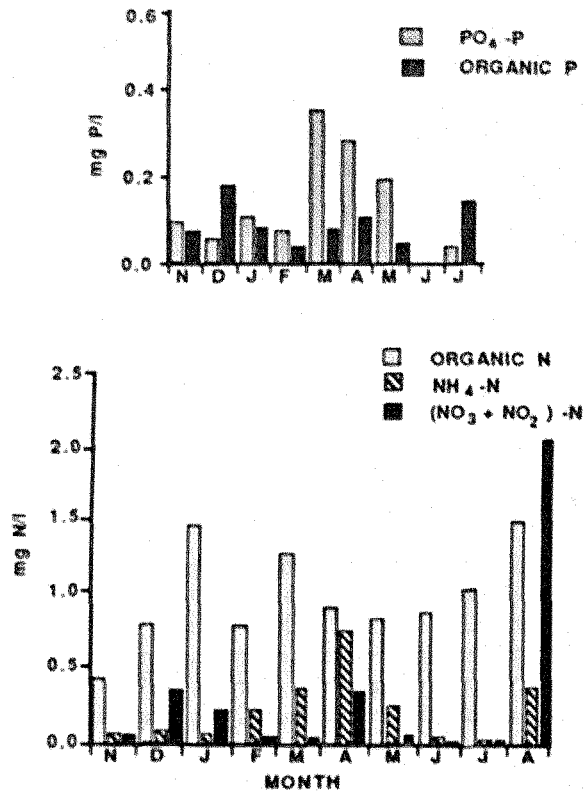


Figure 18. Phosphorus (P) and nitrogen (N) levels in bayous of the upper Barataria Basin (Kemp 1978).

remained in the plant-soil system, indicating efficient N use.

Kemp (1978) speculates that originally the entire upper basin aquatic system was N-limited. Although this condition persists in the lower Barataria Basin (Sklar 1976), the upper basin has recently been described as P-limited by Day et al. (1977) and Seaton and Day (1979). Lantz (1970) reported that increases in eutrophication have paralleled accelerated P loading while N loading has remained constant indicating limitation by P. Nitrogen fixation rather than upland drainage is reported to be the primary source of N to Lac des Allemands (Stow et al. 1985). This is attributed to the fixation of atmospheric N by massive algae blooms in the P-enriched lake. Annual P loading of 4.3 g/m<sup>2</sup>/yr to Lac des Allemands has risen to ten times the critical specific loading level discussed by Vollenweider (1968) and 30 times that calculated by Brezonik and Shannon (1971)

as being the threshold for eutrophic conditions in lakes. Fresh upper reaches of Barataria Basin are especially susceptible to eutrophication because of the lack of tidal flushing.

Studies (Butler 1975; Craig and Day 1977) concur that the P retention capacity of Lac des Allemands is approximately 55% and while the lake acts as a strong sink for P, almost half of the P load is exported to water bodies downstream. A considerable portion of the P in Lac des Allemands is tied up in plant material, and on average, there is three times more P in particulate than in dissolved form. The high water column productivity (net daytime productivity = 611 g C/m<sup>2</sup>/yr; Day et al. 1977) incorporates 10%-15% of the P imported into organic matter, but by far the largest fraction of the des Allemands P load is bound in lake sediments (Stow et al. 1985). Equilibrium studies show bottom sediments in Lac des Allemands are a major sink for incoming dissolved orthophosphate (Stow et al. 1985). Well-oxygenated waters and the presence of an oxidized sediment microzone encourage the trapping of precipitated ferric-phosphates. These compounds, plus phosphate adsorbed to clay particles are trapped in reduced sediments below the oxidized zone. Day et al. (1977), using a mass balance model, estimated that 45% of the P in the lake flows to the sediments, adding 2.0 g P/m<sup>2</sup>/yr to the sediment pool. The lake bottom, in reducing dissolved P concentrations, significantly reduces the potential for eutrophication and buffers the impact of upper basin P loads on middle basin waters. Sedimentation in the lake, ranging from 0.44 cm/yr to 0.81 cm/yr, also removes large amounts of C, N, and P. Carbon, nitrogen, and phosphorus were found to accumulate in the sediment at the rate of 60, 7.1, and 1.1 g/m<sup>2</sup>/yr, respectively (Stow et al. 1985).

### 3.3 MIDDLE BASIN NUTRIENTS

Lake Salvador lies at what is considered the interface of the upper and middle basins and serves to filter out much of the high nutrient load delivered from the upper basin. Much dissolved organic and inorganic material is removed by flocculation in Salvador's brackish waters. The process of flocculation is common in estuaries, occurring where salinity is 2-3 ppt. The ionic environment at this salinity encourages the clumping of clays, silts, and organic particulates into larger particles which readily settle out.

The middle basin, in contrast to the upper basin, experiences gulf tidal effects and alternate seasonal inundations of fresh and salt water, flushing the marshes more efficiently than those in the non-tidal upper basin. As in the upper basin, canals have altered the chemistry and sheet flow hydrology in the middle basin by causing flow to bypass swamp and marsh. Furthermore, canals have altered the circulation and flow patterns within the lake complex itself. Whereas Lake Cataouatche once emptied into Lake Salvador, the creation of the Barataria Waterway, a linear navigation canal, has proved an efficient alternate drainage for Lake Cataouatche, which now empties directly into lower Barataria Bay, effectively isolating Lake Salvador from the middle basin lake system. As a result, nutrient and chlorophyll *a* levels in Lake Salvador are much lower than in the other middle basin lakes. In Lake Cataouatche, the Barataria Waterway, and Barataria Bay, nutrients and chlorophyll *a* concentrations are similarly high (Seaton and Day 1979), indicating that these enriched water bodies form a tightly integrated complex with free circulation among them (Day et al. 1982).

The uncoupling of Lake Salvador from the circulation of the middle basin has resulted in an uneven distribution of nutrients and sediments in the water bodies and a less stable hydrologic regime. Because of its isolation, Lake Salvador, the largest body of water in both the upper and middle basins, can no longer serve as a runoff nutrient processor, and the other lakes are overloaded. Slow moving bayous that once tended to damp the movement of fresh and salt water are now replaced by channels which move water rapidly through the basin. Water level and salinity variations are rapid and extreme, tied closely to precipitation or tidal fluctuations. Salt water now intrudes farther upbasin, and has altered the species composition of the wetland biota.

Land use in the middle basin differs from that in the agriculturally-dominated upper basin. Hopkinson (1978) reported that 40% of the middle basin upland is woodland or open, while only 6% is agricultural (as compared to 71% agricultural in the upper basin). However, much of the input to the middle basin is nutrient-rich urban runoff draining the populated eastern levees near New Orleans. Nitrate concentrations (3.91 mg/l) in the runoff are

quadruple the average runoff concentration in other parts of the basin. Through Bayous Verret and Segnette, 935,000 kg N and 134,000 kg P are imported to the middle basin annually in runoff from the uplands surrounding the middle basin. Additionally, a substantial loading of nutrients is imported to the middle basin through Bayou des Allemands from the upper basin. Butler (1975) calculated this annual export from the upper Barataria Basin to be 8,016,000 kg organic carbon (C), 1,047,000 kg N, and 154,000 kg P. Added to this huge unprocessed export from the upper basin, middle basin upland runoff raises the total loading on the middle basin system to almost 2 million kg N and 228,000 kg P annually, or nearly twice the loading on the upper basin.

Import of C, N and P from the upper basin to Lake Salvador peaks in February with the surge of wet season runoff (Figure 19). Phosphorus loading to Lake Salvador from the upper basin totals 176,000 kg or 0.97 g/m<sup>2</sup>/yr, nearly 100% of which is retained in the lake (Craig and Day 1977). Despite such high nutrient loads, the lake is not eutrophic because the sediments and denitrification act as effective sinks for P and N.

The net daytime productivity (402 g O<sub>2</sub>/m<sup>2</sup>/yr GPP) and chlorophyll *a* concentration (7-12 mg/m<sup>3</sup>) of clear Lake Salvador are low relative to other middle basin waters, and with a community respiration uptake of 602 g O<sub>2</sub>/m<sup>2</sup>/yr this lake displays a moderate degree of heterotrophy (-198 g O<sub>2</sub>/m<sup>2</sup>/yr net community productivity). Heterotrophy is a condition whereby a greater amount of organic material (and oxygen) is consumed than is produced by a system. This indicates that the system is not autosufficient; that is, it requires the import of organic material from outside the system. Lake Cataouatche, although contiguous with Lake Salvador, differs greatly from Salvador in nutrient character. Net daytime productivity (876 g O<sub>2</sub>/m<sup>2</sup>/yr) is double that of Salvador, and the resulting organic material when decomposed by bacteria fuels a strong heterotrophic demand for oxygen. Net respiration in Lake Cataouatche is -1,205 g O<sub>2</sub>/m<sup>2</sup>/yr, resulting in a net community oxygen consumption of -350 g O<sub>2</sub>/m<sup>2</sup>/yr, approaching the heterotrophy of Lac des Allemands (-450 g O<sub>2</sub>/m<sup>2</sup>/yr) and far exceeding that of Lake Salvador and of Little Lake (-117 g O<sub>2</sub>/m<sup>2</sup>/yr NCP; Hopkinson and Day 1979).



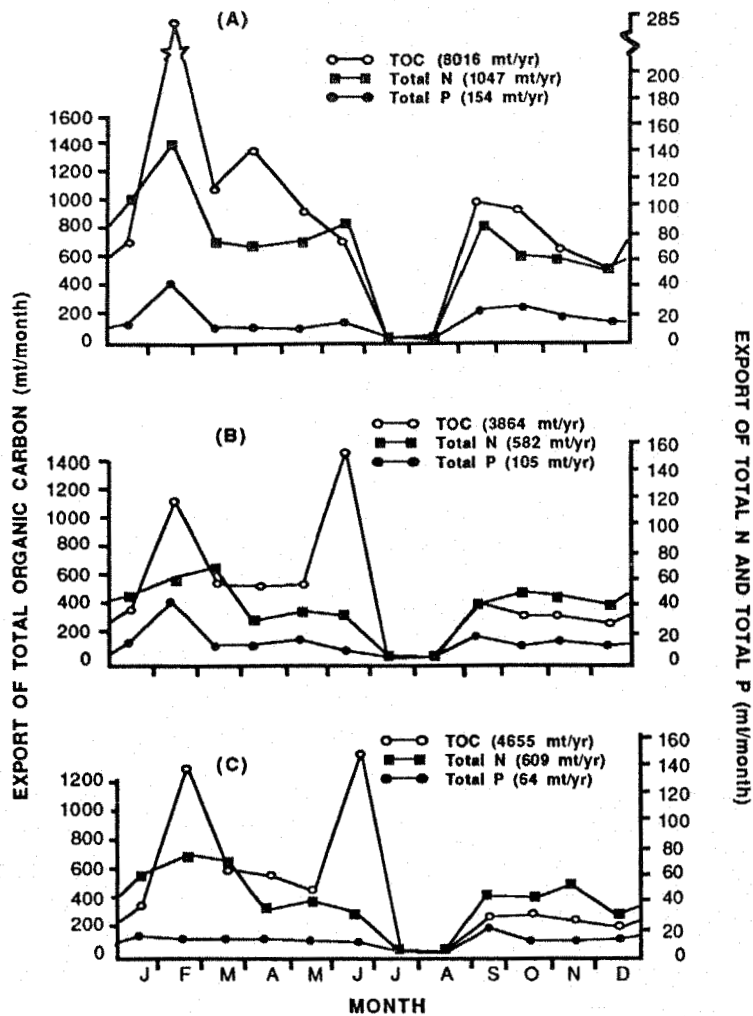


Figure 19. Monthly material export (in metric tons) from the upper Barataria Basin to the lower basin as measured in Bayou des Allemands (A), Bayou Chevreuil (B), and Bayou Boeuf (C) (Butler 1975).

The P loading rates for Lake Cataouatche and Lake Salvador are similar (1.6 and 0.97 g/m<sup>2</sup>/yr), but surprisingly Salvador displays none of the eutrophy plaguing Lake Cataouatche. Several factors in addition to the 40% lower P loading rate account for the high water quality in Lake Salvador:

1. Lake Salvador, with more than four times the volume of Cataouatche, effectively dilutes the nutrient load.
2. Circulation patterns in Lake Salvador tend to hold nutrient inputs along the western shore,

leaving the majority of the lake unimpacted.

3. Bayou des Allemands began carrying large nutrient surpluses into Lake Salvador only recently and the sediments in Lake Salvador still possess a great capacity to store nutrients. In contrast, Lake Cataouatche has drained an urban center for over three hundred years. Continuous inputs during that period have exhausted the sediment buffer.
4. Whereas Lake Cataouatche's reduced sediments release phosphorus to the overlying water column, Lake Salvador is oxygenated

throughout the water column and into the sediments trapping phosphorus in the form of ferric-phosphates and adsorbed phosphates below the oxidized zone (Craig and Day 1977).

Like Lake Salvador, Lake Cataouatche retains 95% of its P input, but in Lake Cataouatche sediment sink processes are not sufficient to prevent continuous algal blooms. The dissolved nitrate level (0.58 mg/l) in Cataouatche is three times Lake Salvador's and particulate organic nitrate (PON) is six times that of Lake Salvador. The mean chlorophyll *a* value in Cataouatche of 55 mg/m<sup>3</sup> is five times the concentration in Lake Salvador. The average basin-wide chlorophyll *a* concentration is 11 mg/m<sup>3</sup>.

Bayou Perot and Bayou Rigolettes are parallel, elongated lakes draining Lakes Salvador and Cataouatche, respectively. Although the water bodies they drain are of very different quality, these bayous are similarly high in water quality and low in nutrient and chlorophyll concentrations. This is of interest considering the very eutrophic character of the Lake Cataouatche source water for Bayou Rigolettes. The 95% P retention capacity of Cataouatche effectively reduces the nutrient levels in its outflow, so at this point in the basin, nutrients are reduced to near-natural levels through biological and chemical processes and from this point on, the basin system shifts from a heterotrophic to an autotrophic state.

Nutrient levels in Bayou Chevreuil in the upper basin exhibit rapid increases in inorganic nutrients during the days following storms (Figure 20; Kemp 1978). This suggests that accumulated nutrients are mobilized quickly by storms and concentrated in the bayous. These precipitation events play an important part in the chemistry of the middle basin; seasonal variations in the nutrient regime are linked to precipitation patterns. In summer, gulf backpressure and high evapotranspiration relative to precipitation combine to stall hydrologic flow, also shutting down the export of nutrients from the upper to the middle basin (Butler 1975). In autumn, when precipitation increases, accumulated nutrients are flushed into the estuary. High concentrations of total P and dissolved organic N are pulsed through the system from the flushing of leachates and detritus.

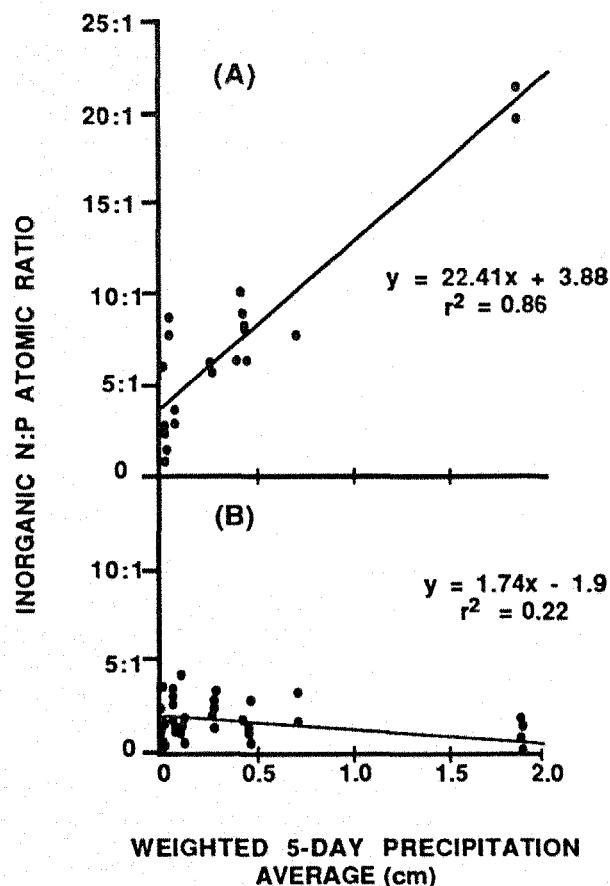


Figure 20. Relationship of precipitation to N:P ratios in Bayou Chevreuil (A) and swamp floodwater (B) (reprinted, with permission, from Kemp and Day 1984, copyright University Presses of Florida).

Hopkinson et al. (1978) described yet another mechanism of nutrient enrichment important in the middle basin. High rates of benthic bacterial respiration have been measured in lake sediments, largely driven by the large organic input from upstream. Bacteria decompose organic material and release N and P in their mineral ammonium and phosphate forms to the environment. Theoretically, this source of liberated "remineralized" P could add another 27 g/m<sup>2</sup>/yr inorganic P to the water column annually.

### 3.4 LOWER BASIN NUTRIENT DYNAMICS

Most of the water reaching the lower basin at Barataria and Caminada Bays is imported from



Little Lake and is of good quality with low chlorophyll *a* of about 9 mg/m<sup>3</sup>, total P of 0.18 mg/l, nitrate of 0.39 mg/l, and ammonium of 0.12 mg/l. The artificially dredged Barataria Waterway serves as a conduit, discharging enriched upper basin water directly into Barataria Bay. However, in the down-basin direction, freshwater runoff becomes less influential to basin chemistry. The Gulf of Mexico, laden with Mississippi River water, becomes increasingly important toward the lower basin and the proportion of Mississippi and Gulf of Mexico water mixing and entering the mouth of the Barataria estuary is controlled by wind, current, tide, sea level, discharge, and precipitation. While the river plume can flow directly into the basin for sustained intervals during spring flood, during periods of low flow, the river does not impact the lower estuary at all. The seasonal importance of the Mississippi River to lower basin nutrient chemistry is evident in the high correlation between river discharge and nutrient levels in the lower Barataria estuary.

In 1973, the Mississippi River flood peaked at its greatest discharge in several years. Ho and Barrett (1977) took this opportunity to make detailed measurements of nutrients along

the Mississippi River plume westward past the Barataria estuary throughout the year. Their objective was to determine the influence of the river on nearshore gulf and estuarine waters under various discharge conditions.

Salinity transects in January 1973 from the upper estuary in Caminada Bay to the gulf crossed a number of distinct water masses. The upper region of Caminada Bay draining freshwater marshes was characterized by low salinities. At Caminada Pass, salinities increased in a gulf water mass trapped by the river plume, but again dropped farther offshore where stations lay in the turbid river plume itself (Figure 21). Silicate, phosphate, ammonium, and nitrate levels had a strong negative correlation with salinity, rising sharply in the riverine water mass, indicating the importance of the river as a source of inorganic nutrients to the lower basin during high-flow periods. In contrast, marsh-drained upper estuary waters were an order of magnitude higher in organic N than gulf or riverine levels.

When river flow is adequate and currents are favorable for directing the plume into the bay, the increased input of nutrients stimulate

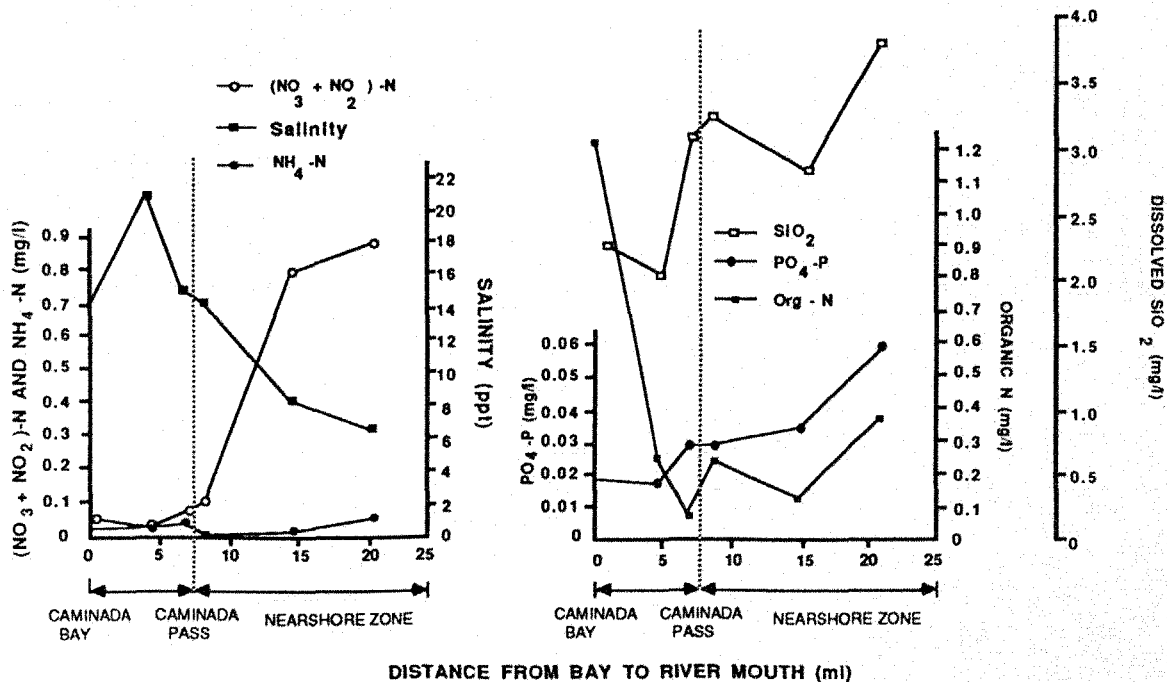


Figure 21. Nutrient profile for Caminada Bay and nearshore Gulf of Mexico during spring flood, 1973 (reprinted, with permission, from Ho and Barrett 1975).

productivity in lower Barataria Basin. During the months of spring flood, Barataria and Caminada Bays often experience an inverted spatial nutrient pattern opposite that of the upper and middle basin pattern of decreasing concentrations downbay. Instead of decreasing at these times, downstream concentrations of inorganic nutrients in the lower basin increase toward the gulf because of the effect of the river. During these periods of high river flow, organic N levels also increase toward the gulf due to increased incorporation into organic matter by phytoplankton production. During periods of low river flow, concentrations of inorganic nutrients and chlorophyll *a* are low and further decrease into the gulf.

The marshes in the lower saline portion of the Barataria estuary are highly productive. Annual marsh net production of 1,176 g organic matter/m<sup>2</sup> measured by Kirby and Gosselink (1976) is equivalent to 590 g C/m<sup>2</sup>/yr. The salt marshes play an active role in the nutrient cycling of the basin. In general, salt marshes are perceived to be a major source of carbon to estuaries and the nearshore zone, and many investigators (Day et al. 1973; Happ et al. 1977; Craig et al. 1979), in estimating high rates of export of C from Barataria Basin, have linked the productivity of the vast Louisiana fishery to the high primary productivity of Louisiana salt marshes. Carbon, in its particulate organic form (POC) and its dissolved form (DOC) is produced in salt marshes as a result of the breakdown of dead organic material and leaching. Day et al. (1973) created a budget to estimate the total community productivity and carbon flow through the estuary. Total marsh aboveground net primary production was estimated to equal 759 g C/m<sup>2</sup> annually. Consumption of the vascular plant and algal production by primary consumers was calculated to approximate 50% of the NPP, leaving 382 g C/m<sup>2</sup>/yr available as detritus for sedimentation in the lower basin, as food, or for export from the estuary. Combined with phytoplankton and benthic algal production, the input of marsh detritus to the waters of the lower basin was calculated to be 750 g C/m<sup>2</sup>/yr for water surface (i.e. not including marsh) of which 432 g C/m<sup>2</sup>/yr was consumed in the water. The fate of the remaining 318 g C/m<sup>2</sup>/yr input to the estuary is the subject of some debate, specifically concerning whether the carbon is exported or sedimented within the basin. Converted to mass per unit of the entire estuary surface in the lower Barataria Basin

(including marsh surface), the surplus available is 178 g C/m<sup>2</sup>/yr.

Day et al. (1973) expected that the entire amount of the surplus was exported from the estuary to the nearshore zone and very little was sedimented. Although no flux measurements were available on which to base this estimate, they find support in the fact that there is no net gain of sediment level in the basin and not more than 0.81 cm of sediment can accumulate each year based on the rate of subsidence. Mineral sediments from resuspension in the basin and Mississippi River inputs contribute to sedimentation, and the organic content of the basin sediment is only about 13%. Day et al. (1973) calculated that 1,053 g/m<sup>2</sup>/yr organic matter or 527 g C/m<sup>2</sup>/yr would account for this input, most of which would be available from root and belowground production. Although there are no root production measurements for these marshes, their argument that most of the organic material withheld from export would come from biomass already emplaced in the ground is reasonable. One may expect that belowground production is greater than aboveground production. Furthermore, since much of the lower basin is not keeping up with subsidence, somewhat less than the 527 g C/m<sup>2</sup>/yr is required to account for annual peat accumulation.

Happ et al. (1977) measured concentrations and fluxes of DOC, TOC, and chlorophyll *a* in the lower basin as a means of determining the fate of C and found evidence for the export of carbon from the Barataria estuary. A gradient of TOC from a high of 8.5 mg/l in waters of fringing marshes to 5.9 mg/l in the lower bay to 2.8 mg/l in the nearshore gulf indicated that marshes are a source of carbon and that there is movement into the gulf. Based on calculations of mixing rates in the estuary by Kjerfve (1972) and a flushing time of 23 days (Austin 1955), Happ et al. concluded that outwelling exports 140-190 g C/m<sup>2</sup>/yr from the estuary, which is near the value calculated by Day et al. (1973).

DeLaune et al. (1978), Hatton (1981), and DeLaune and Smith (1984) measured vertical accretion rates in Barataria Basin marshes using <sup>137</sup>Cs profiles and determined that streamside and inland salt marshes are accreting at the rate of 1.35 cm/yr and 0.75 cm/yr, respectively, from the accumulation of organic detritus and tidally

imported clays and silts. The organic content measured in these soils is about 20%, representing an accumulation of about 240-390 g of organic C/m<sup>2</sup>/yr of marsh surface in the form of peat (Smith et al. 1983), indicating that 50%-75% of annual marsh production must remain on the marsh. Another large percentage is lost as CO<sub>2</sub> and CH<sub>4</sub> gas, leaving much less net carbon to be exported than other studies would indicate (Feijtel 1985). Smith et al. (1983) calculated that an equivalent of approximately 400 g C/m<sup>2</sup>/yr is evolved from the marsh surface as CO<sub>2</sub> and CH<sub>4</sub>. While some CO<sub>2</sub> is recycled back into the marsh through uptake by photosynthesis, most of it is lost to the atmosphere and combined with the carbon accumulated as peat; very little of the production remains to be exported. However, the contribution of belowground production by salt marsh vegetation has yet to be determined, and this fraction may supply much of the accumulated peat, as suggested by Day et al. (1973). The amount of belowground macro-organic matter (MOM) is several times the organic material in aboveground production. Buresh et al. (1980) measured a ratio of MOM fractions to aboveground matter of 5.7 in Barataria salt marshes; however, little is known of turnover rates of belowground production.

Feijtel et al. (1983) synthesized existing carbon flux data and estimated carbon flow along a salinity gradient in Barataria Basin. Using a mass balance approach, they found an estuarine carbon surplus of 130-230 g/m<sup>2</sup>/yr which originated primarily in the tidal salt marsh. Carbon export from marshes to adjacent water bodies decreased with distance upbasin from the Gulf of Mexico.

In contrast to upper basin marshes, which receive almost no mineral sediment, the influx of Mississippi River water through the lower basin mouth provides mineral sediments for salt marshes, augmenting the nutrient supply and enhancing sedimentation. The sediments making up the wetland soils of the basin are largely unweathered recent Mississippi River alluvium. For this reason the marshes usually contain adequate supplies of most of the major plant nutrients such as phosphorus, potassium, calcium, and magnesium as well as essential micronutrients. Barataria Basin salt marshes have been shown to serve as great nutrient sinks (DeLaune et al. 1981), accumulating N and P at rates of 21 g/m<sup>2</sup> and 1.79 g/m<sup>2</sup> annually. The bulk of active plant

roots are found above 30 cm depth and as the marsh accretes, the N and P below this depth become unavailable as a source of nutrients to the plants and are lost from the system.

Enrichment experiments (Patrick and DeLaune 1976; Buresh et al. 1980; DeLaune et al. 1983) have shown N to be limiting to the growth of the *Spartina* salt marshes. Despite the large reservoir of organic N in marsh soils, the short term supply of N to plants is governed by the rate of mineralization of organic N to the ammonium form. In these marshes this occurs at a rate of 25 g N/m<sup>2</sup>/yr and represents 60% of total inputs (DeLaune et al. 1979). Increases of up to 25%-30% in plant biomass and height have been stimulated by the application of supplemental ammonium N to marsh sites. While supplemental P was rapidly taken up by marsh plants, there was no increase in growth response, although luxury consumption increased tissue P concentrations by 20%.

Organic enriched mineral sediments provide the greatest source of N to the lower basin marshes, but a significant part of the N input is contributed by the fixation of atmospheric N by heterotrophic bacteria associated with the marsh plants (Casselmann et al. 1981). Partitioning experiments by Casselman et al. (1981) indicate that negligible fixation occurs in open water or on the plants themselves (only up to 0.2 g N/m<sup>2</sup>/yr) while marsh soil adjacent to plant roots is the site of intense fixation: 4.5 g N/m<sup>2</sup>/yr in inland marshes and 15.4 g N/m<sup>2</sup>/yr in streamside marsh. In the case of streamside marsh this represents almost 40% of the total N budget of the *Spartina* plants.

Tidal fluxes provide the important link between lower basin marshes and the open waters of the lower Barataria Basin, Caminada Bay, and Barataria Bay. Denitrification rates are low in the marsh (approximately 3-4 g N/m<sup>2</sup>/yr; DeLaune et al. 1983) and thus by far the major N loss from the marshes (and consequently the important inputs to open waters) is due to tidal export of detritus. It is estimated that approximately 40% of the net aboveground *Spartina* N production (10-12 g N/m<sup>2</sup>/yr) is lost in this fashion. Because P is not transformed into a gaseous phase in its nutrient cycle, all P export from the salt marsh (1.0 g P/m<sup>2</sup>/yr or about 36% of production) is via tidal export as well. Marsh vegetation is thus pumping N, P, and C from sediment and atmospheric

reservoirs into the lower estuary in the form of leachates and detritus. However, nutrient inputs from the accretion of mineral sediments, nitrogen fixation, rainfall, and the import of organic material from the upper Barataria Basin far exceed the export and loss of nutrients in the lower basin, making the Barataria salt marsh a net importer of N and P.

### 3.5 SUMMARY

The Barataria Basin is a dynamic chemical link between land and sea in coastal Louisiana. In recent years, its hydrology and chemistry have been altered by the natural abandonment of the river channel and by human activity, and what once was a flow-through estuary dominated by riverine processes is now a swamp-lake system whose chemistry is largely controlled by precipitation and tides. Levees have isolated the basin. Canal dredging and increased pollution are creating a steep biological and chemical gradient along the basin characterized by eutrophy and heterotrophy in the upper end and autotrophy in the saline end. Upper basin photosynthesis:respiration ratios (P:R) of 0.71-0.76 (Day et al. 1977) contrast sharply with lower basin P:R ratios of approximately 1 (Allen 1975).

The upper basin may be experiencing problems because natural controls of nutrient fluxes and primary production have been

compromised. Productivity and nutrient levels in the upper basin are tied to the seasonal pattern of precipitation, upland nutrient runoff, and fertilizer application (Stow et al. 1985). Productivity in the middle basin follows a more erratic, aseasonal pattern, and is dependent on water clarity and depth (Day et al. 1982). Winds, river discharge, and tides control nutrient flux and primary productivity in the lower basin.

Sealing of the basin borders with levees has robbed the upper basin of its sediment source, essential to maintaining the wetland against continuous loss to subsidence. In the lower basin, organic accumulation is supplemented by Mississippi River sediment, deposited by tidal inundation. The salt marshes experience an average of 160 major inundations per year, while fresh marshes experience only 20. With a lack of new mineral sediment input, marshes throughout the basin are deteriorating rapidly.

New nutrient inputs each year total only one-fifth to one-half the nutrients regenerated within the basin. The effect of these new inputs is to stimulate higher productivity and also higher recycling rates as more organic material is supplied to benthic remineralizers. High nutrient loads have created an immensely productive heterotrophic upper basin, but the natural buffering capacity in the middle basin has thus far protected downstream waters from eutrophy.

## CHAPTER 4

### VEGETATION: COMPOSITION AND PRODUCTION

by

W. H. Conner, J. W. Day, Jr., J. G. Gosselink,

C. S. Hopkins, Jr., and W. C. Stowe

#### 4.1 INTRODUCTION

The distribution and composition of wetland plant communities within the Barataria Basin has been described by a number of researchers (Penfound and Hathaway 1938; O'Neil 1949; Chabreck 1970, 1972; Chabreck and Linscombe 1978; and Wicker 1980). Primary productivity has been measured in the swamps (Conner and Day 1976; Conner et al. 1981), in the marshes (Kirby and Gosselink 1976; Hopkinson et al. 1978, 1980; Sasser and Gosselink 1984), in the bayous and other water bodies (Allen 1975; Butler 1975; Day et al. 1977; McNamara 1978; Hopkinson and Day 1979), and in the Gulf of Mexico (Sklar 1976). In this chapter the major wetland habitats of the Barataria Basin are described, and the factors influencing species distribution and productivity are discussed.

#### 4.2 AQUATIC PRIMARY PRODUCTION

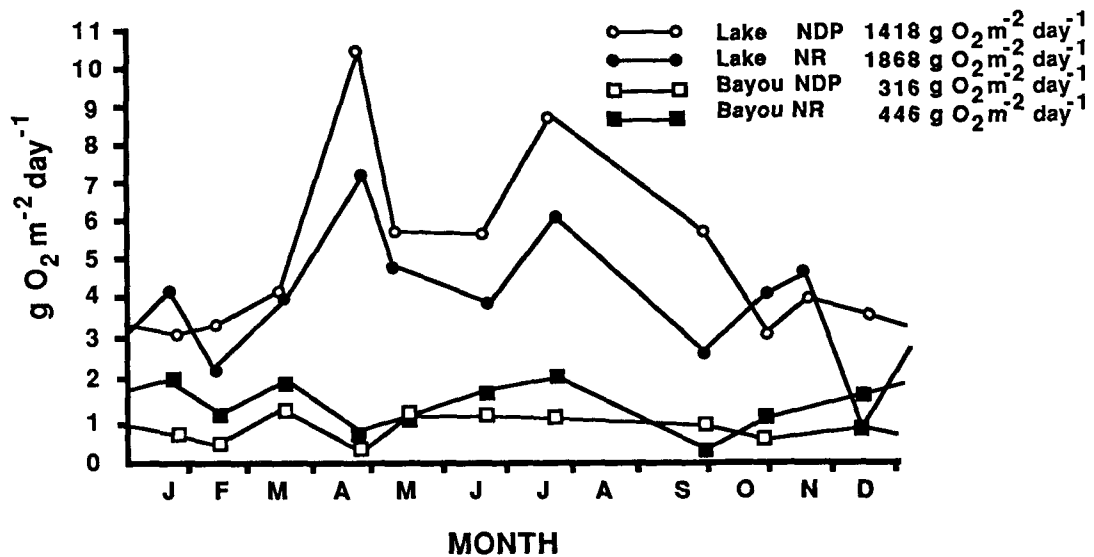
There is a distinct difference between the lower saline part of the basin and the upper fresh water zone in terms of aquatic productivity and community metabolism. Waterbodies in the upper basin have high levels of primary productivity, a pronounced summer pulse, and strongly heterotrophic characteristics. The lower basin aquatic community is less productive and lacks a consistent seasonal trend, and respiration generally balances aquatic primary production. Waterbodies in the upper basin have high nutrient levels leading to high primary productivity. In the lower basin, where light sometimes reaches the bottom, there can be significant benthic primary production. Nutrient levels, water clarity, and water

depth are the parameters which most affect production. Production studies have been conducted by Day et al. (1973,1977), Butler (1975), Allen (1975), Sklar (1976), McNamara (1978), and Hopkinson and Day (1979).

##### 4.2.1. Lac des Allemands

The uppermost lake in the basin, Lac des Allemands, is continuously fresh. It is surrounded by swamp and fresh marsh and receives drainage from a number of bayous and canals which receive runoff from wetlands and uplands, principally agricultural fields. Gross production in the water column of Lac des Allemands is very high (3,286 g  $O_2/m^2/yr$ ), because of nutrient-enriched runoff (Day et al. 1977). There is no seasonal pattern of primary production in the bayous. In Day et al.'s study, Lac des Allemands was productive all year, but production was considerably higher from April through September because of dense blue-green algal blooms. The bayous have a shallower water column, less production (762 g  $O_2/m^2/y$ ) due to shading by overhanging trees and floating vegetation, and high turbidity caused by agricultural runoff. There is no measurable phytoplankton production in water overlying the swamp surface (McNamara 1978).

Both the lake and the bayous are heterotrophic (Figure 22). This reflects the high proportion of wetlands and uplands in the upper basin and the export of organic matter to the waterbodies. The highly eutrophic nature of Lac des Allemands can also be demonstrated by the phytoplankton community. Mean annual phytoplankton density was 52,800 algal units/ml with a



**Figure 22.** Aquatic productivity of Lac des Allemands and Bayou Chevreuil. NDP is net daytime productivity and NR is nighttime respiration (reprinted, with permission, from Day et al. 1977, copyright Academic Press).

range of 18,900 to 93,900 algal units/ml (Day et al. 1977). Seventy percent of the phytoplankton community was composed of blue-green algae. Filamentous *Anabaena* sp., *A. affinis*, *A. flos-aquae*, *Anabaenopsis elenkinii*, and *Lyngbya cotorta* dominated during the late summer while the colonial *Chroococcus minimus*, *C. limneticus*, *Gloeocapsa punctate*, and *Merismopedia tennissima* dominated during the spring. Unicellular and small colonial forms of the green algae were abundant year-round but reached their maximum in the late summer. The dominant organisms in this peak were *Pediastrum biradiatum*, *Scenedesmus quadricauda*, and *Staurastum americanum*. The diatoms, the other major component of the Lac des Allemands phytoplankton community, exhibited a winter maximum with a large number of small pennate forms. Generally the pennate to centric ratio was 4:1. The most common diatom taxa were *Nitzschia* sp., *N. palea*, *N. tryblionella*, *N. dissipata*, *Cyclotella kutziniana*, and *C. menghiniana*.

#### 4.2.2 Central Basin

In the central part of the basin are three lakes that show a transition from fresh to saline

conditions. Lake Cataouatche is a slightly brackish lake (0-2 ppt) with a maximum depth of about 2 m. It is bordered by fresh and intermediate marshes, predominantly bulltongue (*Sagittaria falcata*) and cattail (*Typha* spp.). It receives urban runoff directly from the New Orleans metropolitan area. Lake Salvador is also slightly brackish (0-5 ppt) with a maximum depth of 3 m. It is bordered by cypress swamp and bulltongue marsh. It does not directly receive upland runoff, but receives drainage waters from the upper basin via Bayou des Allemands and from Lake Cataouatche as well as from surrounding wetlands. Little Lake is a tidally-influenced brackish water lake (2-10 ppt) with a maximum depth of less than 2 m. The surrounding marsh is primarily *Spartina patens*. Little Lake receives runoff from surrounding wetlands as well as from the upper basin. In the past, Little Lake was the only waterbody connecting the upper and lower basins. However, the construction of the Barataria Bay Waterway (Figure 3) has caused a shift in the water flow in the basin. Much water which would normally flow through Little Lake now bypasses it and flows through the Barataria Waterway (Hopkinson and Day 1979). Thus it is less affected by upper basin and upland runoff now than in the past.

Productivity patterns in the three lakes reflect the degree to which upland runoff affects the lakes (Figure 23). Gross production was highest in Lake Cataouatche (2,222 g O<sub>2</sub>/m<sup>2</sup>/y), a result of high nutrient loading from upland runoff (Hopkinson and Day 1979). Mean annual chlorophyll in the lake was about 50 mg/m<sup>3</sup>. Gross production in the other two lakes was significantly

organisms in Lake Salvador were *Chlamydomonas* sp., *Chroococcus dispersus*, *Cyclotella menghiniana*, *Diploneus elliptica*, *Gymnodinium fuscum*, *Ochromonas* sp., *Peridinium cinctum*, *Merismopedia tenuissima*, *Trachelomonas hispida*, and coccoid blue-greens. Dominant within Little Lake were *Chroococcus dispersus*, *Chlamydomonas* sp., *Coscinodiscus* sp., *Cryptomonas* lower; however, Little Lake was higher than Lake Salvador (1307 g O<sub>2</sub> as compared to 1058). Mean annual chlorophyll in Lake Salvador and Little Lake was 12 and 10 mg/m<sup>3</sup>, respectively. Nutrient levels in the two lakes were about the same. The higher production in Little Lake seems to be caused by the production by benthic algae. The shallow depth and clear water allow light to penetrate to the bottom at times.

The Lake Cataouatche phytoplankton community reflects eutrophic conditions but at lower levels than Lac des Allemands. Mean annual phytoplankton density for Lake Cataouatche was 25,100 algal units/ml with a range of 16,560 to 31,200 algal units/ml, which is much lower than Lac des Allemands. The dominant blue-greens were the colonial and single coccoid forms. The coccoid forms (which were never satisfactorily identified) were common in all samples. Numbers of colonies peaked in early November and May. The most prominent colonial forms were *Merismopedia punctata*, *Microcystis aeruginosa*, *Gomphospheria* sp., and *Gloeocapsa* sp. Unicellular and small colonial greens were second in prominence with a fall maximum. The most common taxa were *Scenedesmus quadricauda*, *S. quadricauda*, *S. alternata*, *S. acuminatus*, *Chlamydomonas* sp., and *Chlorella vulgaris*. The diatoms, while conspicuous, were less significant producers than in Lac des Allemands. The dominant diatom taxa *Cyclotella striata*, *Diploneus elliptica*, *Nitzschia* sp., *N. linearis*, and *Surirella robusta* were most common during the winter.

Phytoplankton densities in Little Lake and Lake Salvador are lower than Lake Cataouatche with mean annual population densities of 6,500 and 9,200 algal units/ml respectively. Density ranged from 1,500 to 12,300 algal units/ml for Little Lake and from 5,400 to 13,300 algal units/ml for Lake Salvador. In both lakes, diatoms, green algae, and flagellates were more important than blue-green algae. Blue-green algae dominated the winter months, while diatoms were dominant during the spring and fall seasons. The dominant

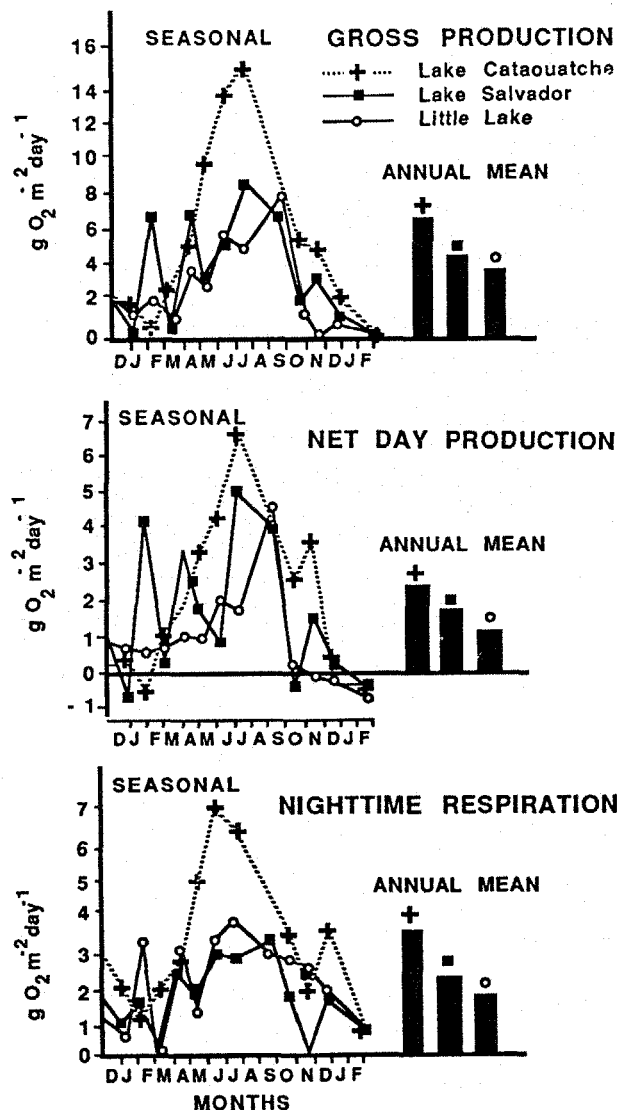


Figure 23. Community gross production, net daytime photosynthesis, and nighttime respiration in three Barataria lakes (reprinted, with permission, from Hopkinson and Day 1979, copyright Plenum Press)

sp., Cylindrotheca fusiformis, Cyclotella sp., Gymnodinium sp., Ochromonas sp., and Peridinium pentagonum.

Hopkinson and Day (1979) found that in Little Lake monthly change in secchi depths (i.e., water clarity) was strongly correlated to the magnitude of production. When water transparency increased (February and April, for instance), significantly higher production took place (Figure 23). Lake Salvador, by comparison, has similar water transparency but is deeper and light never reaches the bottom. All three lakes were heterotrophic, ranging from -350 g O<sub>2</sub>/m<sup>2</sup>/y for Cataouatche to -117 for Little Lake (Table 5). We believe that in the absence of direct upland runoff, waterbodies would have two patterns of productivity. Shallow lakes throughout the basin would have seasonal patterns like Little Lake and Airplane Lake. Deeper lakes would be similar to Lake Salvador.

Seasonal patterns in the three lakes also reflect the impact of nutrient loading, water clarity, and depth. The upper basin is characterized by clear seasonal patterns while the lower basin is oscillatory. Lake Cataouatche with high nutrients and turbidity is similar to Lac des Allemands. There is high productivity from May through September. Lake Salvador also shows a distinct seasonal pattern, but summer production levels are considerably less than in Lake Cataouatche. There is no consistent seasonal pattern in Little Lake. Here water clarity seems to be the major factor

determining production patterns. Lake Cataouatche probably was similar to Little Lake before the introduction of upland runoff, both in terms of total production and seasonal patterns.

Aquatic production in the saline waters of the lower Barataria Basin (Day et al. 1973, Table 5) was somewhat higher than in the nonenriched waters of Little Lake. With the exception of periodic summer blooms, there was not a striking productivity difference between summer and winter (Figure 23). Allen (1975) measured aquatic productivity at four sites in saline and brackish waters in the Terrebonne Basin (west of the Barataria Basin). These waters received very little upland runoff. Both the levels of production and the seasonal patterns were similar to those found in Little Lake and the lower Barataria Basin. The results of these two studies are plotted with those of Nixon and Oviatt (1973) to emphasize the differences between the subtropical coast of Louisiana and a north temperate area in New England (Figure 24). Productivity levels are generally similar from April through September, but production is much lower in New England during the rest of the year.

In a study of Airplane Lake, Day et al. (1973) separated water column and benthic production. Production by benthic diatoms and algae was about 20% higher than by phytoplankton. Thus the results from both Little Lake and Airplane Lake indicated that bottom production is significant. In both of these areas,

**Table 5.** Comparative aquatic productivity (g O<sub>2</sub>/m<sup>2</sup>/yr) and mean chlorophyll *a* concentrations (mg/m<sup>3</sup>) in the Barataria Basin from freshwater bayous to the offshore zone (from Day et al. 1982). NDP = net daytime photosynthesis, NR = nighttime respiration, GP = gross production, and NCP = net community production

	NDP	NR	GP	NCP	Chl <i>a</i>	Reference
Bayous	316	446	--	-130	25	Day et al. 1977
Lac des Allemands	1,418	1,868	3,286	-450	65	Day et al. 1977
Lake Cataouatche	876	1,205	2,222	-350	50	Hopkinson and Day 1979
Lake Salvador	402	602	1,058	-198	12	Hopkinson and Day 1979
Little Lake	639	753	1,307	-117	10	Hopkinson and Day 1979
Brackish-saline	940	910	1,850	0 to + 54	10	Allen 1975 Day et al. 1973
Offshore	732	--	--	--	8	Happ et al 1977; Sklar and Turner 1981



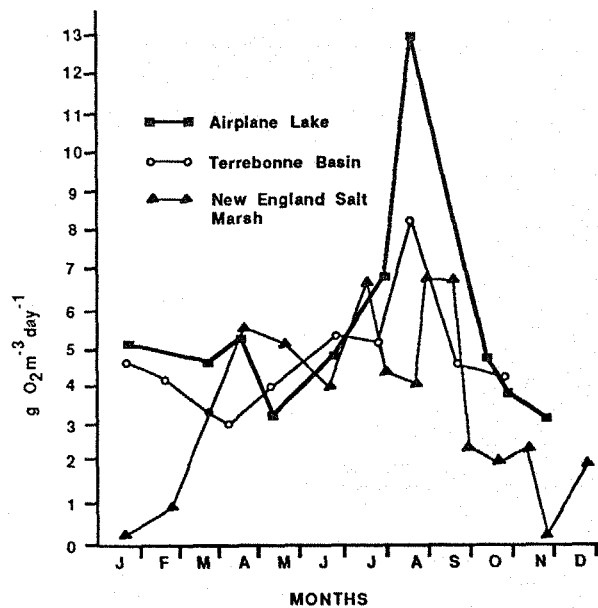


Figure 24. Seasonal gross production curves for Airplane Lake (Barataria Basin), Terrebonne Basin, and New England salt marshes (Allen 1975).

the shallowness of the water was critical in allowing light penetration to the bottom. This happened often enough so that there was significant production. In Airplane Lake the dominant benthic forms were diatoms (Day et al. 1973).

Airplane Lake phytoplankters are dominated by diatoms and dinoflagellates. These phytoplankters have a mean annual density of 16,500 algal units/ml with a range of 7,740 to 28,100 algal units/ml. Dominance is very seasonal; the diatoms predominate during the winter while the dinoflagellates reach their maximum during the summer. The dominant phytoplankters are *Cylindrotheca fusiformis*, *Actinopterychus undulatus*, *Astronella japonica*, *Biddulphia aurita*, *Chaetoceros breve*, *Coscinodiscus* sp., *C. centralis*, *C. radiatus*, *Ceratium hircus*, *Gymnodinium brevis*, *Goniaulax* sp., *Prorocentrum micans*, *P. maximum*, and *P. compressum*.

These results also indicate that the factors controlling productivity change from the upper to the lower basin. In the upper basin, nutrient loading from upland runoff clearly controls both seasonal pattern and the magnitude of production. In the lower basin a combination of water clarity and depth is important.

#### 4.2.3 Nearshore Gulf

The nearshore area off of Barataria Bay is strongly influenced by the discharge of the Mississippi River. This fresh water, being less dense than the salty gulf waters, floats on the surface and moves in variable directions depending on winds, tidal currents, and oceanic currents. Sometimes the plume forms a giant gyre that sweeps in a clockwise direction and directly impinges on the Barataria area. Surface salinities at the coast then drop to low brackish levels.

Light levels, salinity, nutrient concentrations, and productivity are directly related to the influx of Mississippi River water (Sklar 1976). Maximum surface productivity occurred in April during maximum river discharge, whereas the minimum occurred in September when river discharge was low (Figure 25). Surface measurements of annual net productivity were generally higher in turbid coastal waters (brown water) off Barataria Bay than in relatively clear gulf waters (green water) further offshore. Total annual production of 266 g C/m<sup>2</sup> was estimated for the nearshore area off of Barataria Bay. Happ et al. (1977) measured a mean chlorophyll *a* concentration of 7.6 mg/m<sup>3</sup> in these offshore waters. The impact of estuarine outwelling on the nearshore phytoplankton is unknown. However, Sklar and Turner (1981) found that during the winter months when northerly winds decrease the water levels in the marsh, there was evidence that the Barataria Bay exported nutrients, and this increased the primary production of the coastal waters (Figure 25, January).

#### 4.3 WETLANDS OF THE BARATARIA BASIN

Two major aspects of wetland composition from swamp to saline zones are decreasing diversity and increasing consistency of community composition (Table 6). The total number of species identified for each wetland type is: swamp, over 200; fresh marsh, 154; brackish marsh, 23; and saline marsh, 25 (Conner et al. 1986). Stands consistently dominated by *Spartina alterniflora* are common in both the salt and brackish marsh zones. In the fresh marsh, *Panicum hemitomon* covers over 41% of the total area; however, there are large expanses where it is a minor component or absent. In the swamp forest

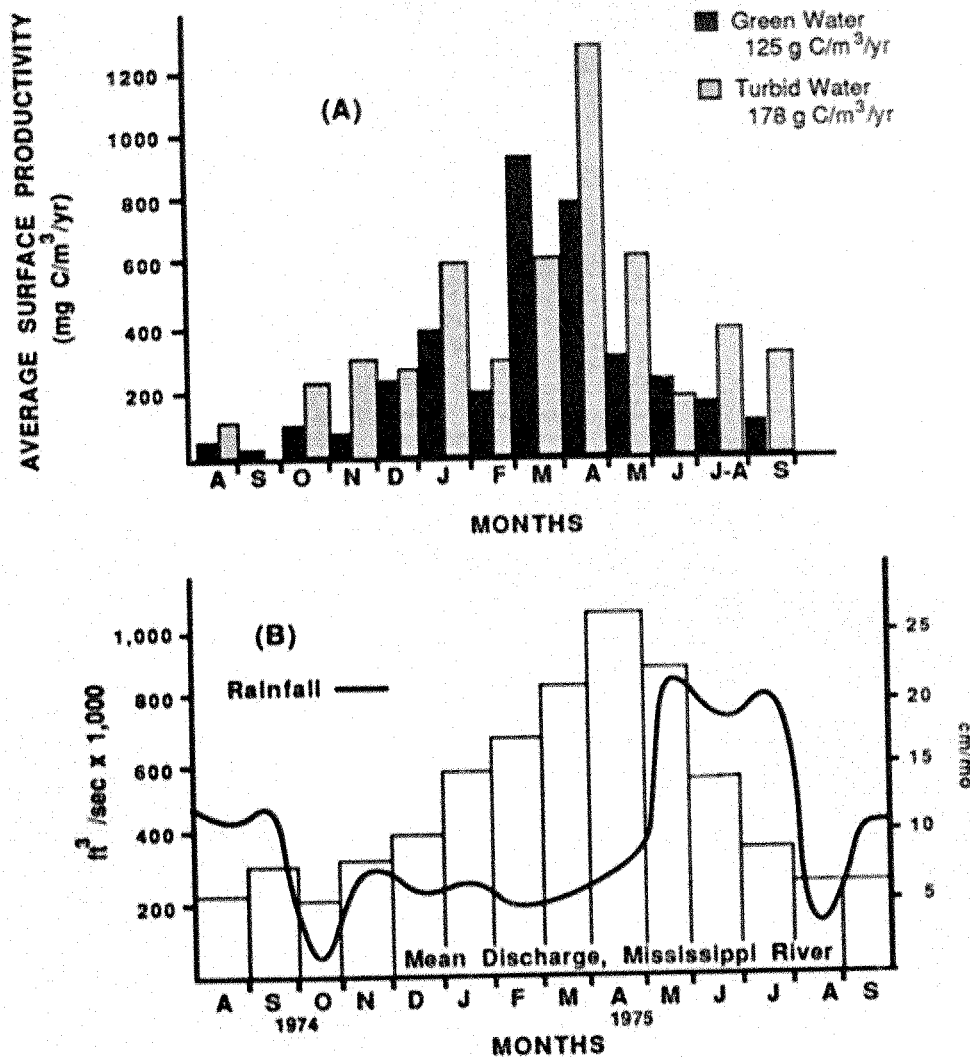


Figure 25. Average primary productivity of offshore surface waters (A) and average annual variation of Mississippi River discharge and rainfall (B). The terms green water and brown water refer to water masses differing in amounts of suspended material. Brown water contains large amounts of matter, probably from marsh inputs and turbulent mixing (Sklar 1976).

Taxodium distichum and Nyssa aquatica dominate in various proportions.

Marsh vegetation zones have been delineated by Chabreck (1972) and Chabreck and Linscombe (1978). None of the zones has a unique flora and many species occur in more than one zone. No species occurs in all marsh types, and only three species, Distichlis spicata, Spartina patens, and Eleocharis spp., compose more than

1% coverage in three zones. S. patens and D. spicata are dominant in the brackish zone, and S. alterniflora and Juncus roemerianus reach highest cover in the saline marsh.

#### 4.3.1. Swamp Forest

The swamp community in the Barataria Bay watershed is strongly affected by water level and drainage. Baldcypress and water tupelo are

**Table 6.** Plant species composition of marshes in the Barataria Basin (after Chabreck 1972).

Specific Name/ Common Name	Percent		
	Fresh	Brackish	Salt
<u>Panicum hemitomom</u> Maidencane	41.4		
<u>Sagittaria falcata</u> Bulltongue	17.4		
<u>Alternanthera philoxeroides</u> Alligator weed	3.4		
<u>Typha sp.</u> Cattail	2.6		
<u>Echinochloa walteri</u> Walter's millet	2.2		
<u>Eichhornia crassipes</u> Water hyacinth	2.0		
<u>Polygonum sp.</u> Smartweed	1.6		
<u>Decodon verticillatus</u> Water willow	1.2		
<u>Vigna repens</u> Deer pea	1.2		
<u>Zizaniopsis miliaceae</u> Giant cutgrass	1.4		
<u>Bacopa monnieri</u> Waterhyssop	1.8	12.0	
<u>Cyperus oderatus</u> Cyperus	3.2	2.7	
<u>Eleocharis sp.</u> Spikerush	12.3	1.8	
<u>Pluchea camphorata</u> Camphorweed		8.4	
<u>Ipomoea sagittata</u> Morning glory		0.7	
<u>Spartina patens</u> Saltmeadow cordgrass		43.9	7.8
<u>Distichlis spicata</u> Saltgrass		16.1	10.1
<u>Eleocharis parvula</u> Dwarf spikerush		2.8	
<u>Scirpus olneyi</u> Olney's three-corner grass		1.7	
<u>Spartina alterniflora</u> Saltmarsh cordgrass		4.5	62.8
<u>Juncus roemerianus</u> Black rush		1.7	14.9
<u>Batis maritima</u> Saltwort			3.1
<u>Salicornia virginica</u> Glasswort			1.2
Others <sup>a</sup>	13.7	2.6	0.2

<sup>a</sup>Includes plants making up less than 1% of the species composition.

characteristic of poorly drained and frequently flooded areas while bottomland hardwoods are found on slightly higher, better drained areas. Brown (1972) stated that a 15-cm difference in wetland elevation is more significant in changing plant communities in Louisiana than 30 cm in mountains. In the Barataria Basin, swamp lands make up 16% of the total area (Table 1).

Of the habitats in the basin, plant diversity is greatest in the swamp forest. Over 200 species of plants have been noted in this area (Conner et al. 1975). Baldcypress and water tupelo are the dominant trees in the Barataria swamp. Drummond red maple (*Acer rubrum* var. *drummondii*), ash (*Fraxinus* sp.), and a number of woody shrubs such as Virginia willow (*Itea virginica*) and buttonbush (*Cephalanthus occidentalis*) are also relatively dominant. In the slightly drier areas, species like cottonwood (*Populus heterophylla*), black willow (*Salix nigra*), hackberry (*Celtis laevigata*), locust (*Gleditsia* sp.), oak (*Quercus* spp.), and hickories (*Carya* sp.) are found.

Cypress lumbering thrived in Louisiana between 1880 and 1925. Unfortunately there are no accurate records to verify how much was cut (Norgress 1936; Mancil 1972). However, the importance of the southeastern Louisiana cypress forests is reflected in the fact that the Louisiana Cypress Company of Harvey and the Lucher and Moore Cypress Company of Lucher (both in or near the basin) were the two largest cypress mills in the world. The extensive network of logging canals that show up on old aerial photographs (still seen on many recent photographs) is also an indication that most if not all of the swamp forests were logged. Only a few virgin trees remain.

#### 4.3.2 Fresh Marsh

The fresh marsh zone begins around Lac des Allemands and extends south to the Gulf Intracoastal Waterway (Figure 3). In all there are 155,030 ha of fresh marsh habitat (including waterbodies) composing about 25% of the basin. Waterbodies constitute a higher proportion of this area than in the swamp forest, but less so than in the brackish and saline marshes (Table 1).

Water levels in freshwater wetlands are controlled more by freshwater inflow, rainfall, and the direction of prevailing winds than by tidal

effects. The total annual inundation time does not vary much across different marsh habitats, but the frequency of inundation (a measure of marsh flushing) is lowest in freshwater areas (Figure 26). As a result, much of the production of the emergent plants accumulates in place. This often gives rise to floatant or floating marsh. Floatant marsh consists of a dense mat of vegetation supported by detritus several feet thick, which is held together by a matrix of living roots and extends outward from the true shoreline. In theory, as the bottom and floating layer accumulate more material, they merge, forming a new shoreline. However, in the Lake Boeuf area this is not happening (Sasser and Gosselink 1984).

One of the most obvious differences between swamp forest wetlands and fresh marsh wetlands is the increase in organic matter content of the soils in the fresh marsh. Much of the detritus deposited on the surface of the fresh marsh is not exported. This added to root production results in a buildup of peat. The organic content of fresh marsh soils is approximately 65%, double that of swamp soils.

Maidencane (*Panicum hemitomon*), or "paille fine" as the French-speaking natives call it, is the dominant plant species in fresh marsh (Table 6), and it is seldom found in other wetland habitats. Bulltongue and spikerush (*Eleocharis* spp.) are also common. Fresh marsh is characterized by more plant species and groups of associated species than any other marsh type. The plant association common to this habitat is the maidencane association which typically includes water hyacinth (*Eichhornia crassipes*), duckweed (*Lemna* spp.), water lettuce (*Pistia stratiotes*), smartweed (*Polygonum punctatum*), bulltongue, bulrush (*Scirpus* spp.), and cattail as minor components.

Brackish and salt marshes are dominated by perennials which form stable communities that change relatively little from year to year. In contrast, fresh marshes support a large number of annual grasses which contribute to the increased plant species diversity seen here. The seeds of some species germinate in the spring and others in the fall. The dominant annual at a given location often changes from season to season or year to year depending on competition and local environmental conditions.

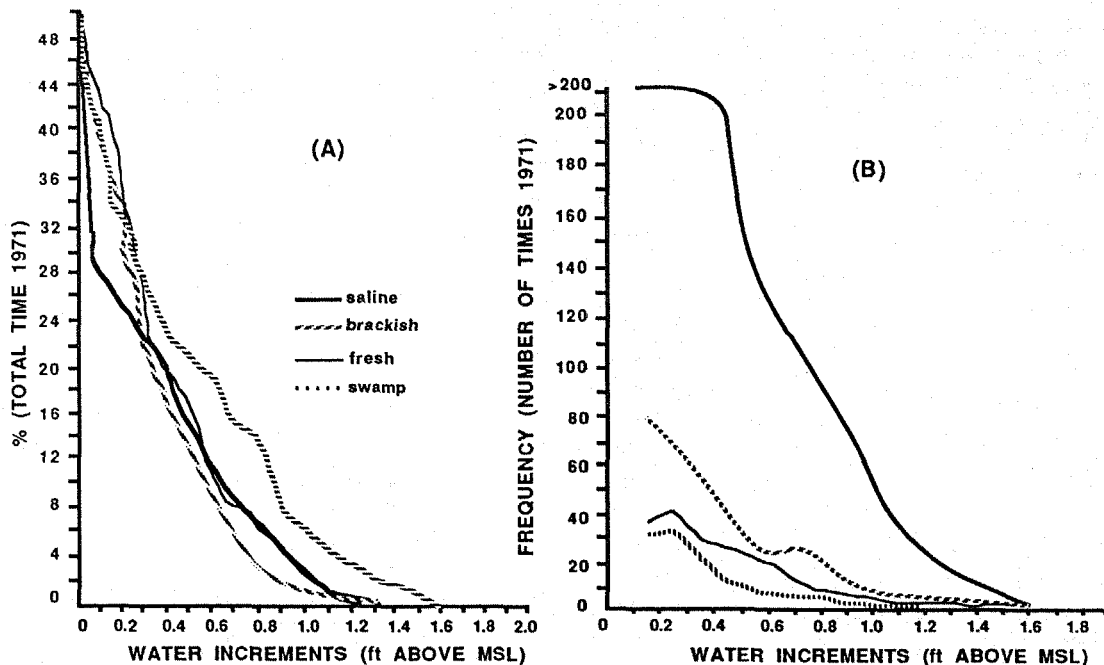


Figure 26. Percent of the year one can expect the water level to be above a specified height (A) and the number of times during the year one can expect the water to exceed a specified height (B) (Byrne et al. 1976).

#### 4.3.3 Brackish Marsh

A broad band of brackish marsh exists in the Barataria Basin. This marsh zone is the most extensive and productive of all wetland types. It also seems to be the most vulnerable to loss since the brackish marsh is disappearing at a rate higher than any other (Craig et al. 1979). This zone represents the first vegetative unit in the salinity gradient to be strongly influenced by tidal action. Salinity averages between 2 to 10 ppt, but can vary from fresh conditions to almost ocean levels. Salinity is strongly influenced by runoff of rain water from the upper basin and by movement of gulf waters up the basin during high tides or storm surges. Storm surges periodically raise water levels and increase salinity. Sustained winds, however, are probably the most important factor in marsh flooding; northerly winds tend to depress water levels, while easterly and south-southeasterly winds tend to increase water levels by forcing water up into the estuary against the slight surface slope. During periods of heavy rainfall these marshes are flushed with freshwater.

The most common plant in the brackish marsh is saltmeadow cordgrass (*Spartina patens*).

Other major macrophytes are *Distichlis spicata*, *Juncus roemerianus*, and *Scirpus* spp. Although freshwater and brackish water bayous are similar in many aspects, the latter differ because of the alternating current patterns. Because of the salinity, floating aquatic plants like *Lemna minor* and *Eichhornia crassipes* are not prominent.

#### 4.3.4 Salt Marsh

Salt marshes have been extensively studied and are the best understood marsh type in the Barataria Basin. Salt marshes are for the most part higher energy habitats than other marsh zones. Though water levels on the marsh are generally shallow, tidal inundation is frequent (Figure 26). Salinities vary seasonally and sometimes daily, depending on climatic factors. Salinities are highest during summer when surplus rainfall is low and gulf water levels are high. Conversely, during spring floods water from the Mississippi River and from the northern part of the basin causes the salinity to drop.

*Spartina alterniflora* is the dominant species of the salt marsh. The saltworts, *Batis*

*maritima* and *Salicornia virginica*, occur to a significant extent only in the saline marsh. An interesting feature of *Spartina alterniflora* stands is the occurrence of distinct height forms along a gradient from streamside to inland. Along the tidal creeks, *Spartina* plants are approximately 1 m tall while further inland they are <50 cm tall (DeLaune et al. 1979).

Even though emergent plants produce the bulk of the energy fixed in salt marshes, epiphytic and benthic algae are also abundant. While epiphytic production is dwarfed by that of the marsh macrophytes, they are highly significant for the quality of their productivity (Mason and Bryant 1975).

In the lower Barataria Bay *Spartina alterniflora*, the dominant emergent plant, serves as a host substrate for four genera of macroscopic algal epiphytes; *Polysiphonia* sp. and *Bostrychia* sp. dominate during the summer while *Ectocarpus* sp. and *Enteromorpha* sp. dominate during the winter (Figure 27A). These epiphytes on *S. alterniflora* are restricted to a horizontal band no wider than 70 cm from the shoreline and usually less than 10 cm wide (Stowe 1972). The microscopic algal community is dominated by diatoms with occasional species of the blue-green genus *Spirulina* being found. The diatoms occur in densities of about  $10^5/\text{cm}^2$  culm surface area and decrease in density with distance from the shoreline and with elevation on the culm (Stowe 1982; Figure 27B). The dominant diatom taxon is *Denticula subtilis* which exhibits an inverse relation with height, increasing in relative abundance with elevation (Stowe 1980). Stowe (1982) gave a detailed analysis of the diatom community associated with *S. alterniflora*.

#### 4.4 WETLAND PRODUCTIVITY

##### 4.4.1 Swamp Forest

Functionally, the swamp forest is similar to the marshes. Seasonal flooding provides optimum conditions for growth (Conner and Day 1976; Conner et al. 1981). Flooding, however, varies from area to area within the swamp. This is illustrated for three sites in the Barataria Basin (Figure 28). Water levels fluctuate depending mainly upon rainfall, which causes the water level to rise during and after rainfall and fall between

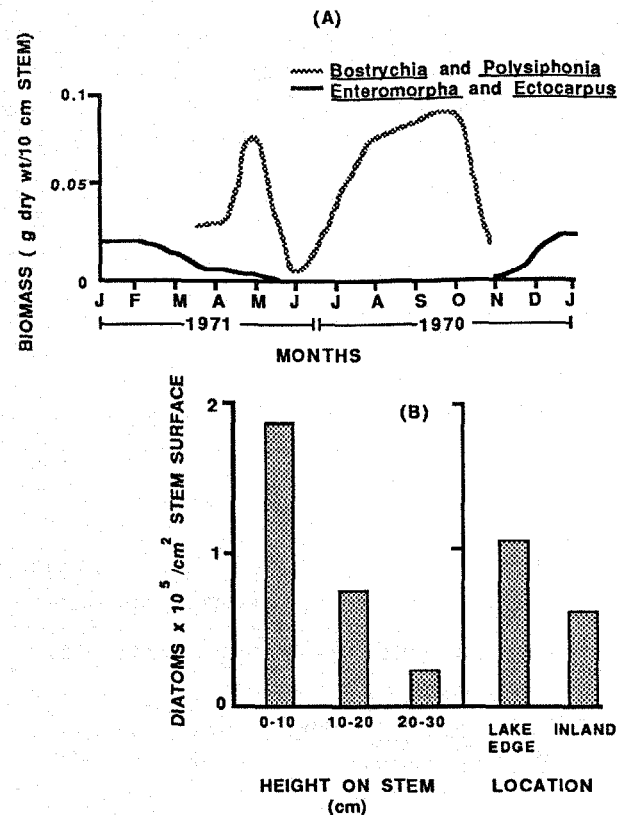


Figure 27. The seasonal biomass cycles of the major macroscopic algae in the salt marsh (A) and density and occurrence of microscopic epiphytes (B). "Inland" in the lower graph represents all the marsh area over 70 cm from the lake edge (Stowe 1972).

storms. In a controlled system like the crayfish farm, however, water levels are kept at about 40 cm through the winter and spring. During the summer the area is normally dry.

Stem productivities and litterfall have been measured in the three areas for 3 years (Table 7). Even though the stem growth of individual baldcypress and water tupelo in the permanently flooded area (Figure 29) is greater than in the other areas (presumably the result of reduced competition and greater sunlight), the fewer number of trees in that area results in lower areal productivity (Conner et al. 1981). Average aboveground net production values of 1344, 906, and 1915 g dry wt/m<sup>2</sup>/yr have been measured in the seasonally flooded, permanently flooded, and crayfish farm, respectively.

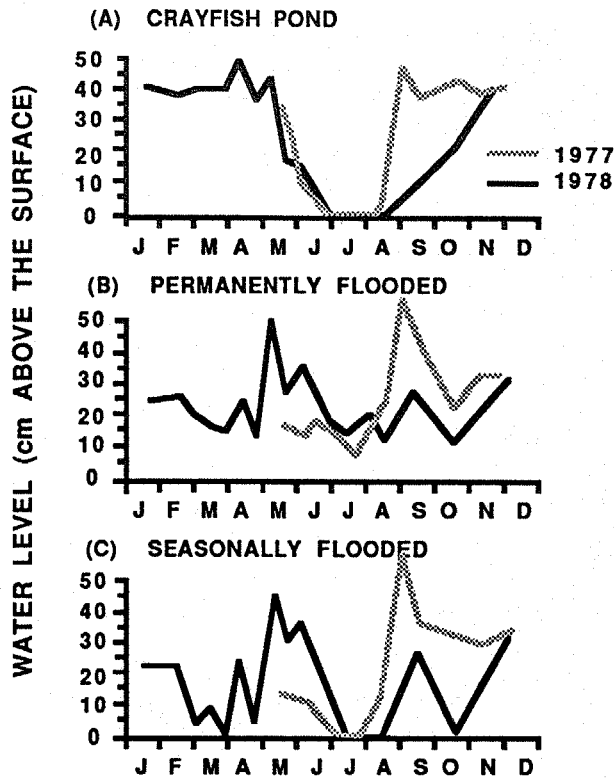


Figure 28. Water level fluctuations in three swamp areas (reprinted, with permission, from Conner et al. 1981, copyright American Journal of Botany). Water depth in this case refers to depth above the forest floor.

Table 7. Aboveground net primary production (NPP) in three swamp sites.

Species or component	NPP (g dry wt/m <sup>2</sup> /yr)		
	1978	1979	1980
<b>Stem Production -- Seasonally flooded --</b>			
Baldcypress	646.0	858.3	839.9
Water tupelo	57.9	120.6	53.9
Others	44.9	62.5	60.4
<u>Litterfall</u>	<u>417.4</u>	<u>447.8</u>	<u>417.8</u>
<b>TOTAL</b>	<b>1,166.2</b>	<b>1,489.2</b>	<b>1,372.0</b>
<b>Stem Production -- Permanently flooded --</b>			
Baldcypress	209.9	212.8	256.2
Water tupelo	149.1	202.5	153.6
Ash	48.6	62.2	60.0
Others	150.8	176.6	176.4
<u>Litterfall</u>	<u>328.7</u>	<u>271.8</u>	<u>257.1</u>
<b>TOTAL</b>	<b>887.1</b>	<b>925.9</b>	<b>903.3</b>
<b>Stem Production -- Crayfish farm --</b>			
Baldcypress	387.8	523.6	628.4
Water tupelo	57.8	63.8	59.6
Ash	453.1	468.1	360.8
Others	332.4	390.4	380.1
<u>Litterfall</u>	<u>614.0</u>	<u>571.4</u>	<u>518.7</u>
<b>TOTAL</b>	<b>1,845.1</b>	<b>2017.3</b>	<b>1947.6</b>

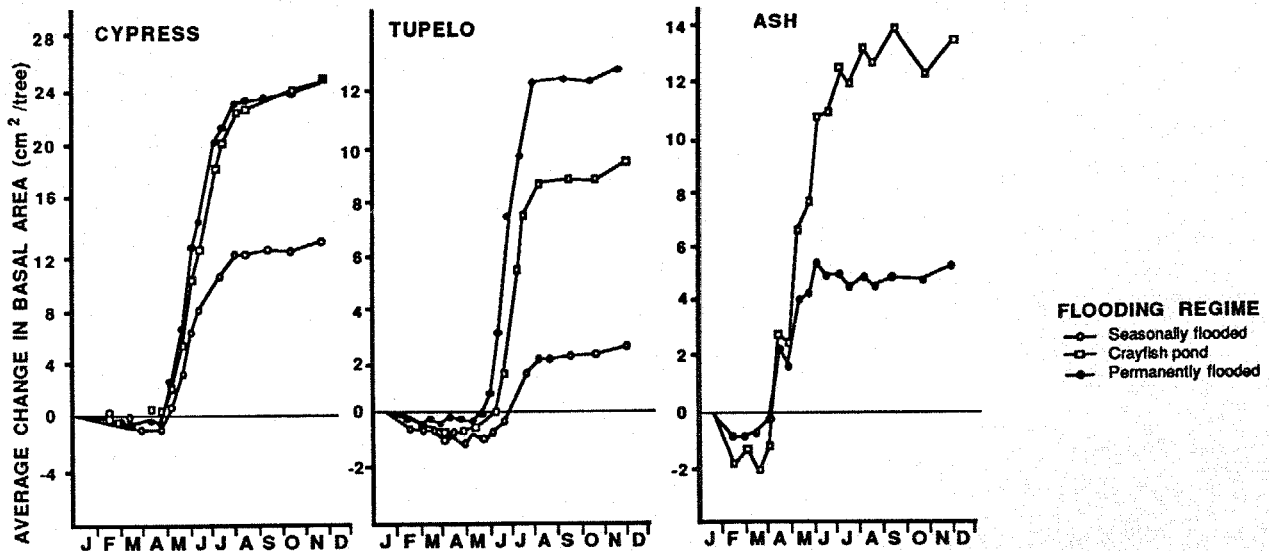


Figure 29. Seasonal stem growth patterns for three major tree species in the Barataria swamp forest (reprinted, with permission, from Conner et al. 1981, copyright American Journal of Botany).

At first glance, these results indicate that the productivity of the permanently flooded area is nearly as high as for the seasonally flooded swamp. However, the marketable forest species in the flooded area are declining because of a lack of recruitment. Only 943 trees/ha are found in the permanently flooded area as compared to 1,303 trees/ha in the seasonally flooded swamp and 1,564 trees/ha in the crayfish farm. A significant portion of the productivity of the permanently flooded area is due to small shrubs like buttonbush, snowbell, and maple which are becoming dominant as the tupelo, baldcypress, and ash die or are blown over.

#### 4.4.2 Marshes

We estimated the average productivity of each marsh type using measured and estimated productivity values for species which occur there (Table 8). For the brackish and saline marshes, we were able to account for a large percentage of the production with production values measured in Louisiana; therefore the average values should be fairly accurate. For the fresh marsh, however, a high percentage of the over-all average is based on estimates. Thus, these values must be considered tentative. We will consider reasons for this pattern in the next section.

**Table 8.** Estimated aboveground net primary productivity for each marsh habitat.

Species	NPP (g dry wt/m <sup>2</sup> /yr)	Coverage (%) <sup>a</sup>	Contribution to total NPP (g dry wt/m <sup>2</sup> /yr)
<b>FRESH MARSH</b>			
<i>Sagittaria falcata</i>	1,501 <sup>b</sup>	17.4	261
<i>Alternanthera philoxeroides</i>	3,140 <sup>c</sup>	3.4	107
<i>Typha</i> sp.	1,420 <sup>d</sup>	2.6	37
Other <sup>e</sup>	--	76.6	<u>1,548</u>
<b>Total NPP</b>			<b>1,953</b>
<b>BRACKISH MARSH</b>			
<i>Spartina patens</i>	6,043 <sup>b</sup>	45.8	2,768
<i>Distichlis spicata</i>	3,237 <sup>b</sup>	29.0	939
<i>Spartina alterniflora</i>	2,658 <sup>b</sup>	9.0	239
<i>Juncus roemerianus</i>	3,416 <sup>b</sup>	3.3	113
Others <sup>e</sup>	--	12.9	<u>495</u>
<b>Total NPP</b>			<b>4,554</b>
<b>SALT MARSH<sup>f</sup></b>			
<i>Spartina alterniflora</i>	1,450 <sup>b</sup>	62.8	911
<i>Juncus roemerianus</i>	3,416 <sup>b</sup>	14.9	509
<i>Distichlis spicata</i>	3,237 <sup>b</sup>	10.1	327
<i>Spartina patens</i>	6,043 <sup>b</sup>	7.8	<u>471</u>
<b>Total NPP</b>			<b>2,218</b>
<sup>a</sup> Chabreck (1972). <sup>b</sup> Hopkinson et al. (1978). <sup>c</sup> Boyd (1969). <sup>d</sup> Whigham et al. 1978. <sup>e</sup> Productivity assumed to be equal to the average of other species in the habitat. <sup>f</sup> Kirby and Gosselink (1976) assume 70% inland area and 30% streamside area and the salt marsh acreage was divided up using these percentages in order to calculate this figure.			



Brackish marshes have the highest overall aboveground net primary productivity of all marsh types in the Barataria Basin, followed by saline and fresh marshes (Table 8). This results from high production values reported for S. patens, the dominant species in this marsh type. For those species whose productivity has been measured in the Barataria Basin, S. patens is apparently the most productive, followed by J. roemerianus, D. spicata, S. alterniflora, and S. falcata (Table 8).

The productivity of two freshwater marsh species has been studied in coastal Louisiana. Hopkinson et al. (1978) measured the productivity of Sagittaria falcata at 1,501 g dry wt/m<sup>2</sup>/yr (Table 8). Phragmites australis was slightly more productive at 2,318 g dry wt/m<sup>2</sup>/yr. Production of these two species was seasonal, with the highest rates in summer and lowest rates in winter. Peak live biomass occurred in June for S. falcata and in late summer for Phragmites (Figure 30). Minimum values of winter live biomass were very low for both species. Dead biomass exhibited the opposite pattern for both species. This type of seasonal production is common in the fresh marshes because of the abundance of annual species. Though fresh marshes have not been studied as much as salt marshes, Whigham et al. (1978) showed in a summary of productivity data from fresh marshes along the Atlantic coast that they can be as productive as salt marshes.

The production of Spartina patens and Distichlis spicata reaches a maximum in the brackish marshes (Payonk 1975; Hopkinson et al. 1978; Cramer et al. 1981). Net primary production was 3,237 g dry wt/m<sup>2</sup>/yr for D. spicata and 6,043 for S. patens. Both species had considerable live standing biomass throughout the year. There was a seasonal trend for both live and dead biomass for D. spicata, but there was no clear trend for S. patens (Figure 30).

Production of salt marsh grasses is generally high. Net aboveground production of S. alterniflora was measured by Kirby and Gosselink (1976) and Hopkinson et al. (1978). The measurements for streamside productivity were close; 2,645 and 2,658 g dry wt/m<sup>2</sup>/yr, respectively. Both researchers reported clear seasonal patterns for both live and dead biomass (Figures 30 and 31). Peak live biomass occurred in late summer while dead biomass reached a peak in mid winter and a minimum in late summer. Loss of

dead grass is due to decomposition and physical flushing of the marshes by tides. Loss rates are low in winter due to low water levels and low temperatures which inhibit decomposition. Loss rates are highest in the spring because of higher temperatures, more frequent flooding, and a high biomass of dead Spartina. Production 50 m inland was 1,323 g dry wt/m<sup>2</sup>/yr (Kirby and Gosselink 1976), one-half of streamside productivity.

Hopkinson et al. (1978) also measured the production of Juncus roemerianus and S. cynosuroides as 3,416 and 1,355 g dry wt/m<sup>2</sup>/yr, respectively. There was a clear seasonal pattern for live biomass for S. cynosuroides but not so for dead biomass (Figure 30) or for dead or live standing crop for Juncus. A significant difference in biomass between Barataria Bay and other areas of the U.S. is the low proportion of live to dead vegetation. On an average annual basis, there is always more dead material than living, with live to dead ratios in the Barataria area ranging from 0.21 to 0.91. Using end-of-season biomass maxima, a live to dead ratio of 0.7 to 1.0 was obtained. This is much less than 5.3 from Georgia (Smalley 1958) or 2.1 for Maryland (Keefe and Boynton 1973). Turner and Gosselink (1975) reported ratios in Texas averaging 1.5, slightly higher than in the Barataria Bay. These low ratios may be a reflection of high turnover rate of live vegetation and low tidal energy of the Louisiana coast (Hopkinson et al. 1978).

#### 4.5 FACTORS AFFECTING MARSH PRODUCTIVITY

Studies in Louisiana and elsewhere suggest that nutrients and hydrology are important in determining production levels. These two factors are highly interrelated and do not act separately. Patrick and DeLaune (1976) reported that additions of nitrogen, but not phosphorus, stimulated short Spartina growth in Barataria marshes. The standing crop of tall Spartina was not affected by the application of fertilizer.

This finding is consistent with other environmental studies from the Atlantic coast (Sullivan and Daiber 1974; Valiela and Teal 1974; Broome et al. 1975; Gallagher 1975; Mendelssohn 1979). Although this seems to indicate that the short form is nitrogen limited, other factors may be involved. Mendelssohn (1978, 1979) suggests that intense soil anaerobiosis resulting from poor

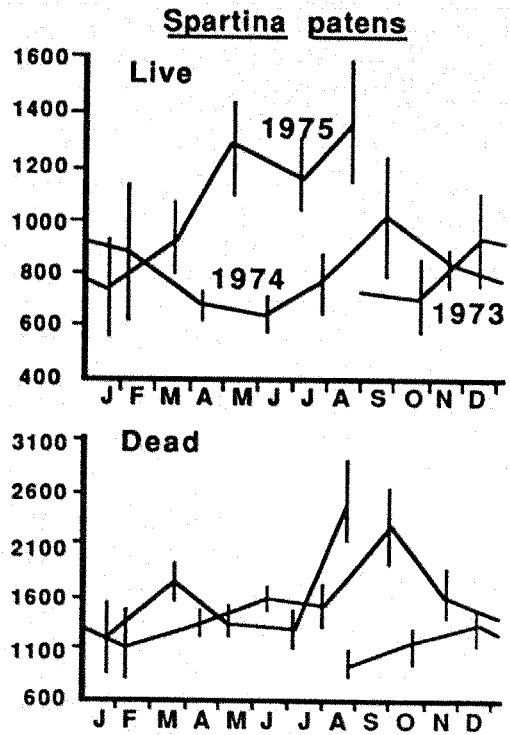
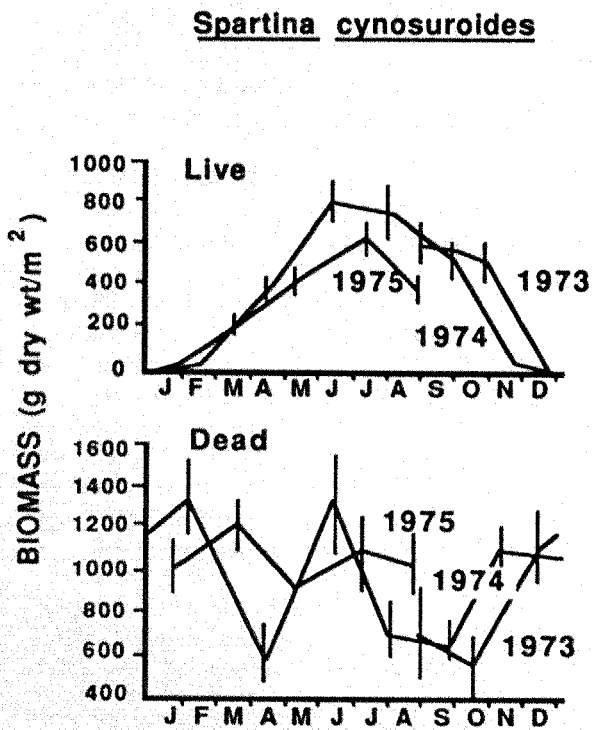
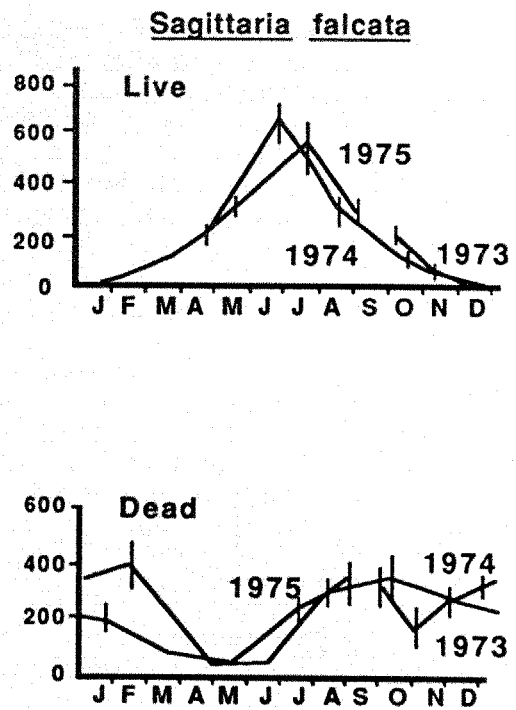
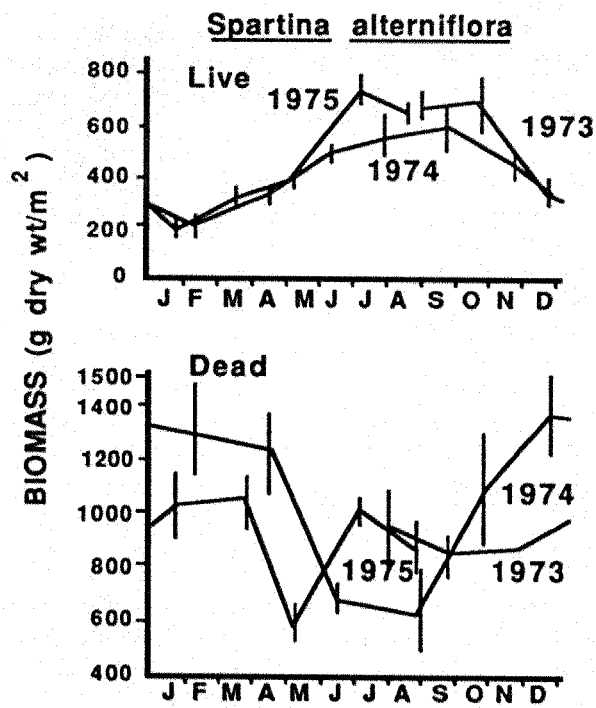
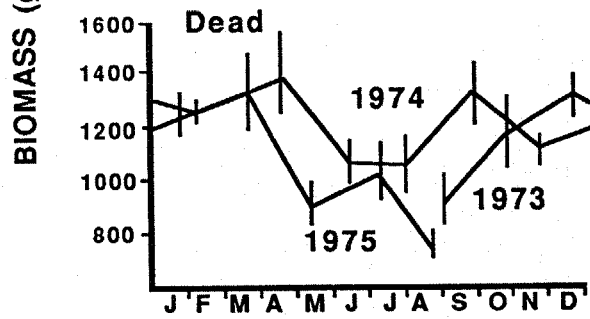
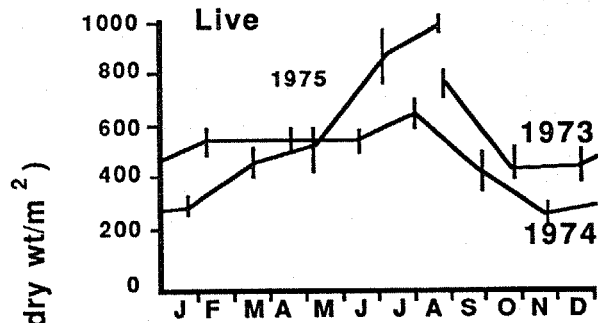
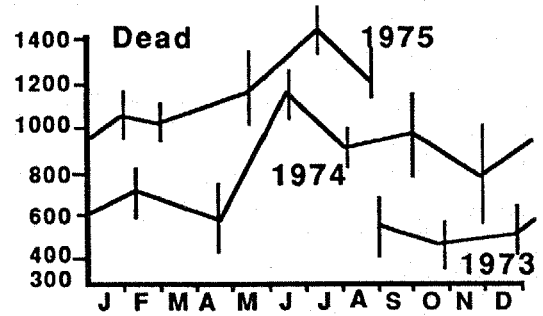
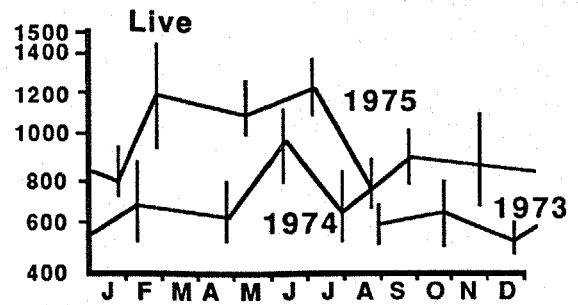


Figure 30. Seasonal changes in live and dead biomass of some of the more dominant marsh plants

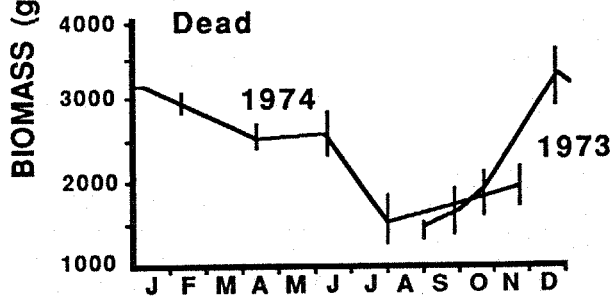
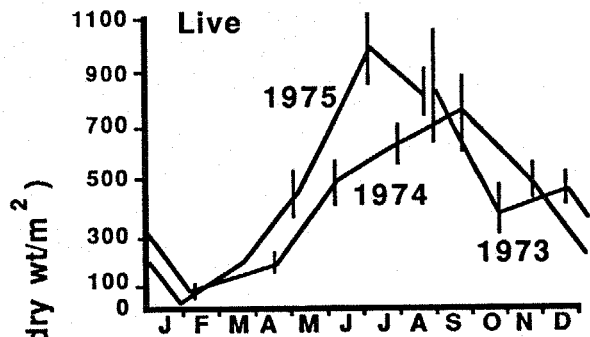
Distichlis spicata



Juncus roemerianus



Phragmites communis



(reprinted, with permission, from Hopkinson et al. 1978, copyright Ecological Society of America).

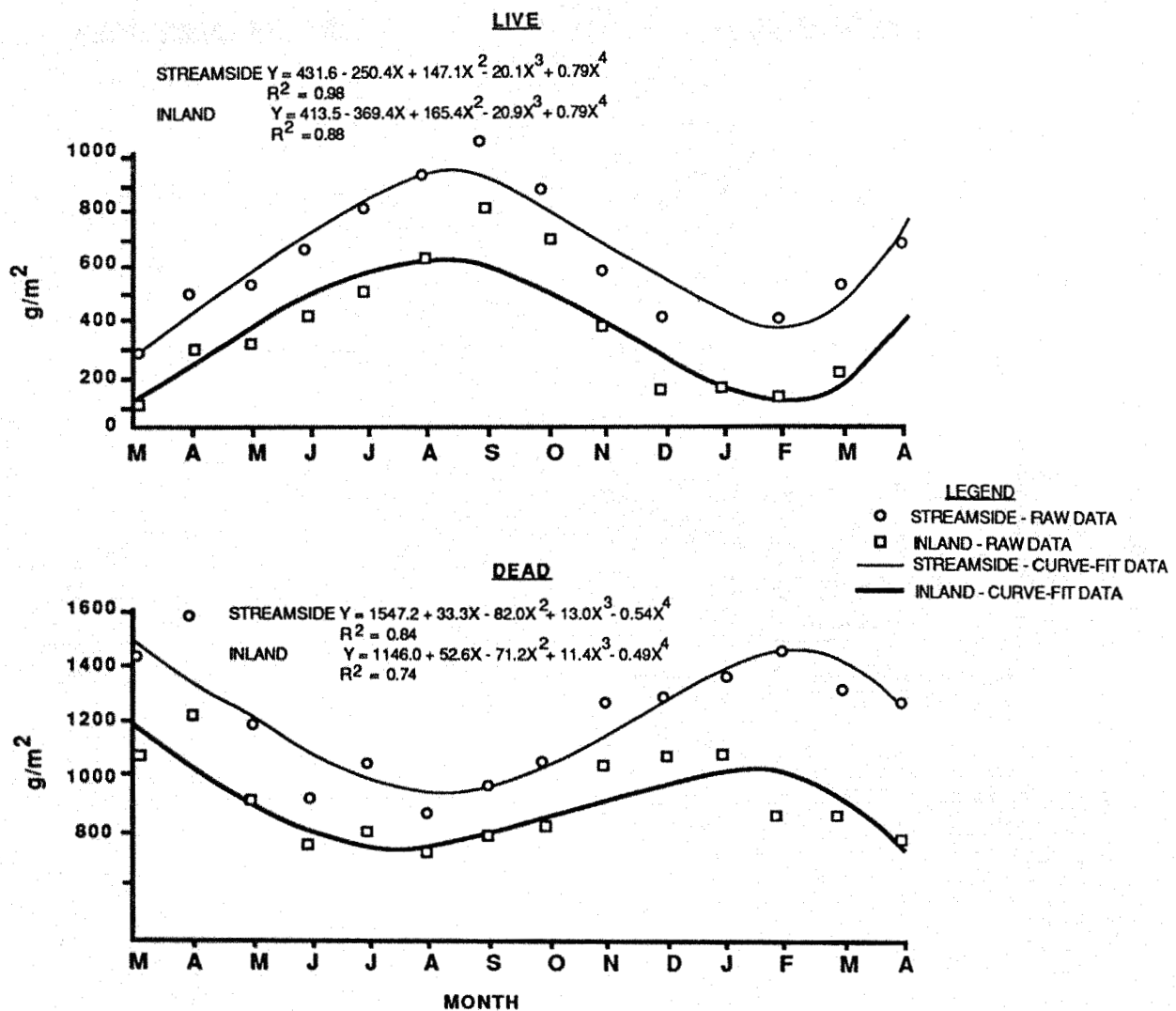


Figure 31. Live and dead standing crop of streamside and inland *Spartina alterniflora* (reprinted, with permission, from Kirby and Gosselink 1976, copyright Ecological Society of America).

soil drainage may inhibit nitrogen uptake directly by decreasing the amount of oxygen available for active uptake or indirectly by generating substances which are potentially toxic to active nutrient uptake. This inhibition is overcome with the application of nitrogen fertilizer because the concentration gradient of available nitrogen into the root is increased. The lack of an increase in standing crop of the tall form after fertilization may be due to greater input of nutrient enriched suspended sediments (DeLaune et al. 1979), and to the fact that these are primarily aerobic (Mendelsohn et al. 1981) whereas the inland

areas receive less sediment and are primarily anaerobic.

Several studies have shown that alteration of normal hydrological conditions can affect structure and productivity of wetlands. Mendelsohn et al. (1981) reported that hydrological modifications of salt marshes that cause increased waterlogging may affect plant productivity. As an example, the Leeville oil field lies on the western boundary of the Barataria Basin in *Spartina alterniflora* marsh. There is a dense network of canals dug for access to drilling sites.

Spoil disposal levees line many of the canals. Allen (1975) reported that estimated standing live *Spartina* biomass was 50% lower in marshes surrounded by spoil banks than in a comparable control site. In the same area, the density of natural tidal channels was inversely related to the density of artificial canals (Craig et al. 1979). On a broader level, the erosion rate of wetlands was correlated with the density of canals (Craig et al. 1979). Erosion is part of the deltaic cycle, but the present rate is 3-4 times higher than would occur naturally (Craig et al. 1979).

The pattern of highest marsh productivity in the mid-Barataria Basin (Table 8) may be caused by a combination of hydrologic factors and nutrient levels. The upper basin is characterized by higher nutrient levels and the lower basin by much more frequent flushing of marshes by tidal action. We have shown that both of these factors are related to marsh productivity. It may be that the optimum conditions for marsh growth occur where there are enriched waters and enough tidal action so that marshes are flooded regularly (Schelske and Odum 1961).

#### 4.6 SALT MARSH EPIPHYTIC ALGAE

Epiphytic algae have been studied only in the salt marshes (Stowe 1972, 1980, 1982). In general, the productivity is low compared to that of the vascular plants. Production dynamics are a reflection of several interacting factors: shading by the *Spartina* canopy, the seasonal dominant macroscopic algal form, water level, salinity, frequency of flooding, and temperature. Stowe (1972) studied the structure and productivity of microalgal communities on the shore of Airplane Lake and 1.5 m into the marsh. The shoreline community receives direct sunlight all year and maintains a higher level of production.

In terms of their relative productivities, the shoreline and inland microalgal communities are very distinct (Figure 32A,B). The shoreline community exhibited maximum rates of production during the periods of *Bostrychia* and *Polysiphonia* dominance. The inland community was always very low. Net productivity of the inland community

was negative during most of the year. Only during periods of thinning *Spartina* and low temperatures was the inland community a positive net producer. Both communities have very high respiration rates (Figure 32C). Integration of the area under the curves for gross production and respiration show the shoreline community to contribute a net of 16 g C/m<sup>2</sup>/yr to the water column while the inland community required an additional input equivalent to 63 g C/m<sup>2</sup>/yr for maintenance to account for measured levels of respiration.

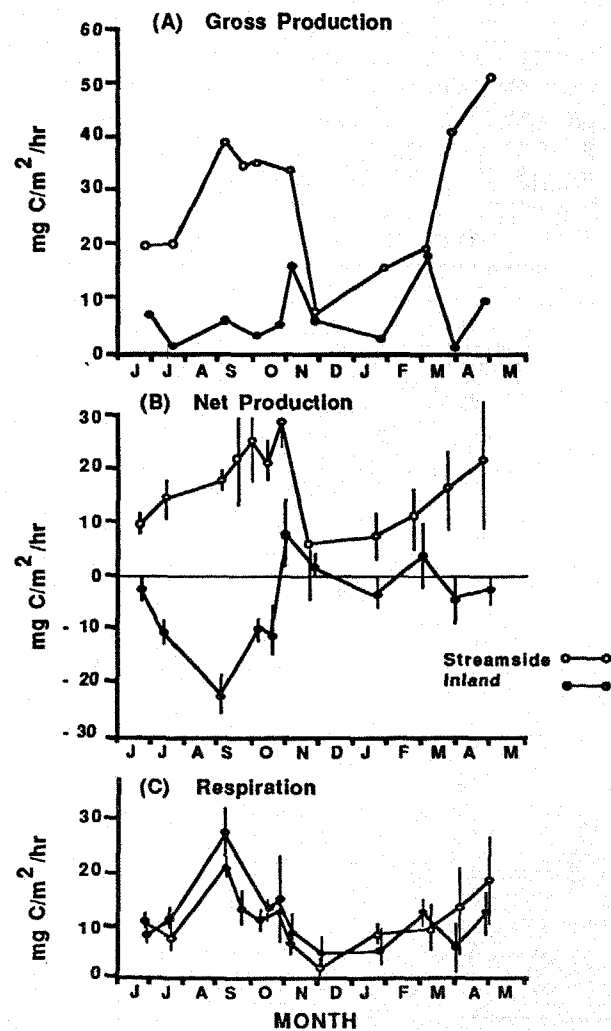


Figure 32. Metabolic rates of the epiphytic community associated with *Spartina alterniflora* (Stowe 1972).

## CHAPTER 5 ZOOPLANKTON

by  
W. H. Conner and J. W. Day, Jr.

### 5.1 INTRODUCTION

As primary consumers, zooplankton are important organisms in estuarine food webs. They provide one of the links between primary producers, predominately marsh grass and phytoplankton, and higher trophic levels. Many commercially important fish depend on zooplankton, both as adults and postlarvae, as their primary food source. The bay anchovy (*Anchoa mitchilli*) the most abundant fish in brackish water of the Barataria Basin (Wagner 1973; Chambers 1980), depends largely upon zooplankton throughout its life (Darnell 1961).

Along the Louisiana coast there have been few detailed studies of zooplankton. Two studies investigated zooplankton populations in the Barataria Basin. Gillespie (1971, 1978) inventoried the zooplankton of Barataria and Caminada Bays as part of a study of the nearshore and inshore saline waters along the entire Louisiana coast. Bouchard and Turner (1976) characterized zooplankton along a salinity gradient from fresh to salt water in and adjacent to the Barataria Basin (sampling locations for these studies are given in Figure 33). Other studies in Louisiana have been conducted by Darnell (1961), Stern and Stern (1969), and Stone et al. (1980) in

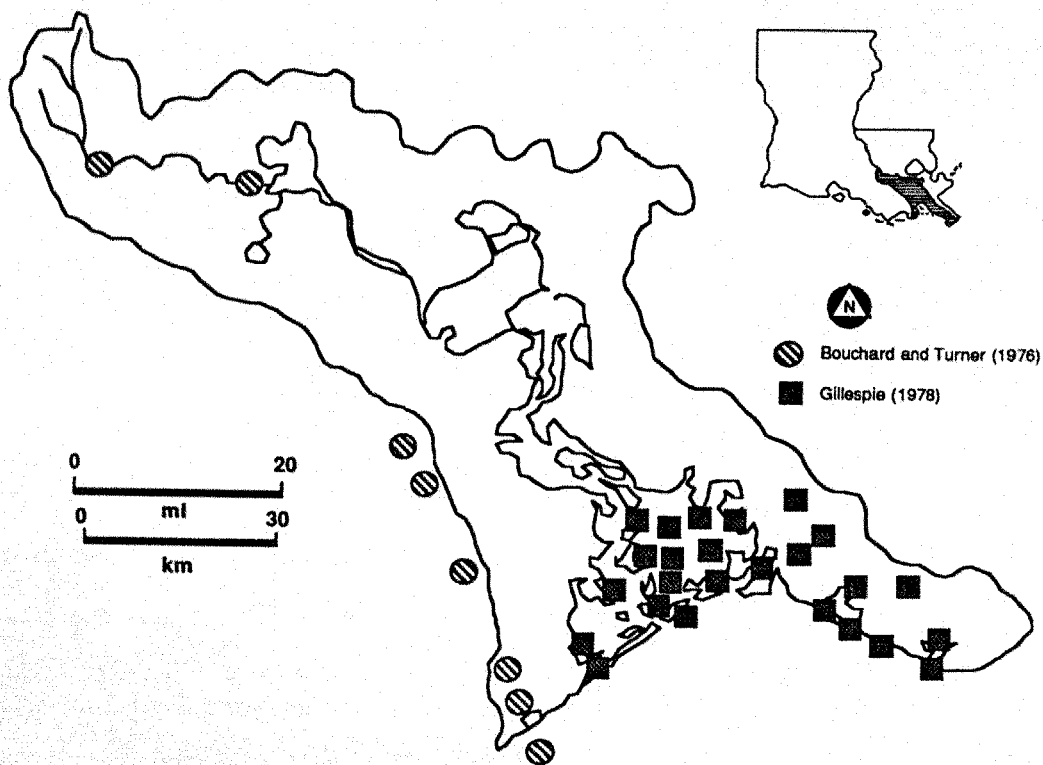


Figure 33. Location of zooplankton sampling stations within and adjacent to Barataria Basin.

Lake Pontchartrain, Cuzon du Rest (1963) in Chandeleur and Breton Sounds, and DeNoux (1976) in the Calcasieu Estuary. It is the purpose of this chapter to describe species composition and distribution, seasonal variations, and food habits of zooplankton within the Barataria Basin and to compare patterns found here to those in other estuarine areas.

## 5.2 SPECIES COMPOSITION AND DISTRIBUTION

Studies within the Barataria Basin indicate that the zooplankton community is dominated by copepods, especially the genus Acartia (see Table 9 for a complete listing of the zooplankton species

**Table 9.** List of zooplankton found in the Barataria Bay estuarine complex with the habitat in which they have been collected. NS = nearshore waters, SM = saltmarsh, BM = brackish marsh, FM = fresh marsh, and SW = swamp (Sources: Gillespie 1971,1978 and Bouchard and Turner 1976).

Species	Habitat
Protozoa	NS
<u>Noctiluca scintillans</u>	NS,SM
Hydrozoa	NS,SM,FM,SW
Ctenophora	NS,SM,BM,FM,SW
Rotifera	NS,SM,BM,FM,SW
Nematoda	SM
Pelecypoda, larvae	NS,SM,SW
Gastropoda	NS,SM
Mollusca	
Pelecypoda - larvae	NS,SM,SW
Gastropoda	NS,SM
<u>Laevapex</u> sp.	FM,SW
Annelida	
Polychaeta - larvae	NS,SM,BM
Oligochaeta	FM,SW
Hirundinea	FM,SW
Cladocera	
<u>Alona</u> spp.	BM,FM,SW
<u>Bosmina longirostris</u>	FM,SW
<u>Ceriodaphnia lacustris</u>	SW
<u>C. laticaudata</u>	FM,SW
<u>C. reticulata</u>	SW
<u>C. rigaudi</u>	FM,SW
<u>Pseudochydorus globosus</u>	FM,SW
<u>Chydorus sphaericus</u>	FM,SW
<u>Dadaya macrops</u>	SW
<u>Daphnia ambigua</u>	SW
<u>D. laevis</u>	SW
<u>D. parvula</u>	FM,SW
<u>Diaphanosoma brachyurum</u>	FM,SW
<u>D. luchtenbergianum</u>	FM,SW
<u>Eubosmina tubocin</u>	SW
<u>Euryalona occidentalis</u>	FM,SW

Table 9. Continued.

Species	Habitat
<u>Evadne tergestina</u>	NS,SM
<u>Ilyocryptus spinifer</u>	FM,SW
<u>I. sordidus</u>	FM
<u>Kurzia latissima</u>	FM,SW
<u>Latonopsis fasciculata</u>	FM
<u>L. occidentalis</u>	FM
<u>Leydigia acanthocercoides</u>	FM,SW
<u>L. quadrangularis</u>	SW
<u>Macrothrix rosea</u>	FM
<u>M. laticornis</u>	FM
<u>Moina micrura</u>	FM,SW
<u>Moinodaphnia macleayii</u>	FM,SW
<u>Penilia avirostris</u>	NS
<u>Podon polyphemoides</u>	NS
<u>Scapholeberis kingi</u>	FM,SW
<u>Simocephalus exspinosus</u>	FM,SW
<u>S. vetulus</u>	FM
Copepod	
Calanoida	
<u>Acartia tonsa</u>	NS,SM,BM,FM
<u>A. spinata</u>	NS,SM
<u>A. danae</u>	NS,SM
<u>Candacia bipinnata</u>	NS
<u>Centropages hamatus</u>	NS,SM,BM
<u>C. furcatus</u>	NS
<u>Diaptomus dorsalis</u>	FM,SW
<u>D. reighardi</u>	FM,SW
<u>D. siciloides</u>	FM
<u>Eucalanus pileatus</u>	NS
<u>Euchaeta marina</u>	NS
<u>Eurytemora hirundoides</u>	NS
<u>E. affinis</u>	FM
<u>Labidocera aestiva</u>	NS
<u>Mormonilla sp.</u>	NS
<u>Osphranticum labronectum</u>	FM,SW
<u>Paracalanus sp.</u>	NS,SM
<u>Pontella sp.</u>	NS
<u>Pontellopsis sp.</u>	NS
<u>Pseudodiaptomus coronatus</u>	SM
<u>Rhinocalanus cornutus</u>	NS
<u>Temora turbinata</u>	NS
<u>T. stylifera</u>	NS
<u>Tortanus sp.</u>	NS
<u>T. setacaudastus</u>	SM
<u>Undinula vulgaris</u>	NS
Cyclopoida	
<u>Clytemnestra scutellata</u>	NS
<u>Copilia mirabilis</u>	NS
<u>Corycaeus sp.</u>	NS



Table 9. Continued.

Species	Habitat
<u>Cyclops nearcticus</u>	FM
<u>C. panamensis</u>	BM,FM
<u>C. rubellus</u>	FM,SW
<u>C. thomasi</u>	SW
<u>C. vernalis</u>	SM,FM,SW
<u>Ectocyclops phaleratus</u>	FM,SW
<u>E. speratus</u>	FM,SW
<u>Eucyclops</u> sp.	BM
<u>Halicyclops fosteri</u>	NS,FM
<u>Macrocyclus albidus</u>	FM,SW
<u>M. ater</u>	FM,SW
<u>Mesocyclops edax</u>	FM,SW
<u>M. inversus</u>	FM,SW
<u>M. longisetus</u>	FW
<u>Oithona</u> sp.	NS,SM
<u>Oncaea mediterranea</u>	NS
<u>O. conifera</u>	NS
<u>Orthocyclops modestus</u>	SW
<u>Paracyclops poppei</u>	SW
<u>Saphirella</u> sp.	NS,SM,BM
<u>Sapphirina nigromaculata</u>	NS
<u>Tropocyclops prasinus</u>	FM,SW
Harpacticoida	
<u>Altheutha</u> sp.	SM,BM,FM,SW
<u>Ergasilus</u> sp.	NS
<u>Euterpina acutifrons</u>	SM,BM,FM,SW
<u>Macrosetella</u> sp.	NS
Caligoida	
<u>Caligus</u> sp.	NS
Arguloida	
<u>Argulus</u> sp.	SM,BM,FM,SW
Ostracoda	NS,SM,BM,FM,SW
<u>Cypis</u> larvae	SM
Amphipoda	NS,SM,FM,SW
<u>Atylus</u> sp.	NS
<u>Gammarus mucronatus</u>	NS
<u>Cerapus</u> sp.	NS
<u>Hyperia</u> sp.	NS
<u>Caprella</u> sp.	NS
Isopoda	
<u>Aegathoa oculata</u>	NS
<u>Sphaeroma quadridentatum</u>	NS
<u>Edotea montosa</u>	NS
<u>Synidotea</u> sp.	NS
Cumacea	
<u>Oxyurostylis smith</u>	NS
Mysidacea	
<u>Mysidopsis almyra</u>	NS
Stomatopoda larvae	NS

Table 9. Concluded.	
Species	Habitat
Decapoda	
<u>Penaeidae</u> larvae	NS,SM,BM,FM
<u>Acetia americana carolinae</u>	NS
<u>Lucifer faxoni</u>	NS,SM
<u>Leander tenuicornis</u>	NS,SM
<u>Brachyura</u> , zoeae and megalops	NS,SM,BM,FM,SW
<u>Callinectes sapidus</u>	NS,SM
<u>Procambarus clarkii</u>	FM,SW
<u>Palaemonetes</u> sp.	NS,SM
Arachnida	BM,FM,SW
Insecta larvae	SM
Coleoptera larvae	BM,FM,SW
Diptera larvae	SM,BM,FM
Ephemeroptera nymphs	FM,SW
Hemiptera	FM
Odonata nymphs	FM,SW
Ophiurae	
<u>Ophioplutens</u> larvae	NS
Chaetognatha	
<u>Sagitta hispida</u>	NS,SM
Urochordata (tunicates)	NS,SM
<u>Oikopleura</u> sp.	NS,SM
<u>Doliolida</u> sp.	NS
Fish eggs and larvae	NS,SM,BM,FM,SW

reported from the basin). Bouchard and Turner (1976) found A. tonsa made up about 51% of the annual average zooplankton count from oligohaline to polyhaline waters. Gillespie reported that A. tonsa accounted for from 48% to 67% of average annual zooplankton counts. Gillespie (1971) found A. tonsa in all salinity (0.3 - 30 ppt) and temperature (5 to 35 °C) ranges encountered in her study. This species has been reported as dominating zooplankton populations in different areas along the northern gulf coast from Texas to Florida (Davis 1950; Simmons 1957; Woodmansee 1958; Cuzon du Rest 1963; Hopkins 1966; Gillespie 1971, 1978; Bouchard and Turner 1976). Other important copepod species found in the Barataria Basin were Centropages hamatus, Cyclops sp., Diaptomus sp., Ectocyclops phaleratus, Eucyclops sp., Oithona sp., Pseudodiaptomus coronatus, Temora sp., and Toranus sp.

Gillespie (1971) reported that ctenophores were often the most conspicuous zooplankters in high salinity waters of the Barataria Basin. Ctenophores were taken throughout most of the year, especially during the summer (Gillespie 1971, 1978). The most common species were Beroe ovata and Mnemiopsis mccradyi.

Meroplankton were often abundant in zooplankton tows. Fish larvae and fish eggs were found throughout the Barataria basin. Fish larvae consisted primarily of Brevoortia patronus, Anchoa mitchilli, Menidia beryllina, and Mugil cephalus.

#### 5.2.1 Freshwater

Both brackish and freshwater species were captured in the freshwater stations. Population concentrations were not high, but the

diversity (68 taxa) was much greater than in more saline areas.

Rotifers, copepods, and cladocerans were the dominant organisms in freshwater samples. When the rotifers reach peak productivity, which occurs once or twice a year, they may constitute almost the entire zooplankton community. During this period, the individual rotifers often measure less than 0.1 mm and volumetrically compose a smaller portion of the sample than the actual numbers suggest. Cladocerans were the most diverse group of zooplankters with 17 species identified. Cladocerans, like cyclopoid copepods, were present yearround, but never in large numbers. All cladocerans except Diaphanosoma and Moina spp. were strictly freshwater species. The calanoid copepods were represented by the freshwater species, Diaptomus dorsalis, D. reighardi, D. siciloids, and Osphrantium labronectum; the brackish water species, Eurytemora affinis; and the euryhaline species, Acartia tonsa. Several oligohaline cyclopoid copepods species were found in fresh water: Cyclops vernalis, C. panamensis, Eucyclops sp., and Tropocyclops sp. Eight species of cyclopoid copepods were found in the freshwater samples; only one brackish water species, Halicyclops fosteri, was noted.

Copepod nauplii occurred in small numbers throughout most of the year. Cirriped

nauplii (barnacle) and brachyuran (true crabs) zoeae occurred in small numbers in the latter part of the year and were not found at all during the rest of the year.

The back swamp was rich in both numbers and diversity of zooplankton. Cyclopoid copepods dominated the community, making up about 50% of the total population each month. Eucyclops agilis, Tropocyclops prasinus, and Cyclops vernalis were the most abundant cyclopoids. Rotifers were not overly abundant, except in November when they composed about 40% of the zooplankton assemblage. The cladoceran species composition changed throughout the year as various species of the 25 identified species of cladocera replaced each other. Moina micrura was the dominant cladoceran in August. Daphnia sp. were the most dominant species in September. Diaphanosoma branchyurum became dominant in October. Ceriodaphnia sp. predominated in November and March, and were replaced by Simocephalus expinosus in December and January. Chydorus sphaericus predominated in February.

#### 5.2.2 Brackish Waters

The zooplankton population in the oligohaline zone was low in both numbers and diversity (Table 10). Only 21 taxa were identified.

Zone	Bouchard and Turner (1976)		Gillespie (1978)	
	Avg. No./m <sup>3</sup>	#sp.	Avg. No./m <sup>3</sup>	No. sp.
Coastal waters (offshore/nearshore)	83,960	16	9,227	37
Inshore saltwaters	19,158	28	5,246	31
Brackish waters	1,417	21		
Freshwaters	12,682	68		
Backswamp	29,078	59		

Unfortunately, quantitative data is limited to samples taken from July 1973 to March 1974. *Acartia tonsa* and copepod nauplii were the most numerous zooplankters, but neither were present in abundant numbers. Three cyclopoid copepods were identified: *Cyclops panamensis*, *Eucyclops* sp., and *Saphirella* sp. *C. panamensis* had not previously been reported from brackish waters, and it was not known whether this species was a true resident or one that had been washed in with freshwater.

### 5.2.3 Inshore Salt Waters

Bouchard and Turner (1976) found high zooplankton counts in saline open waters, although species diversity was not very high (Table 10). Copepod nauplii and *Acartia tonsa* were the most common zooplankters, present in significant numbers in all samples throughout the year. Cyclopoid copepods, represented by *Cyclops vernalis*, *Oncaea mediterranea*, *Oithona* sp., and *Saphirella* sp. were numerous through most of the year. Brachyuran zoeae dominated the salt marsh zooplankton community for part of the summer with as many as 45,700/m<sup>3</sup> at one station (August 1973). Harpacticoid copepods, rotifers, polychaetes, opossum-shrimp (Order Mysidacea), and isopods were occasional members of this community.

Figure 34 shows seasonal zooplankton densities estimated by Gillespie (1978) at both northern and southern locations within Barataria Bay from October 1974 to September 1976. *Acartia tonsa* dominated the bay community, occasionally comprising 100% of the community. Maximum zooplankton counts reached 18,000/m<sup>3</sup> in the northern bay and 70,500/m<sup>3</sup> in the southern bay. Decapods and numerous copepods were present throughout much of the year in significant numbers. Fish larvae and fish eggs were present throughout the year, and were more abundant in the southern bay. Chaetognaths, pelecypods, polychaetes, cladocerans, calanoid copepods, nauplii, and ostracods were occasional inhabitants of both locations.

### 5.2.4 Coastal Waters

Greater concentrations of zooplankton were encountered in the coastal waters than in any other zone (Table 10). Species numbers ranged from 37 taxa, identified by Gillespie (1978), to 16

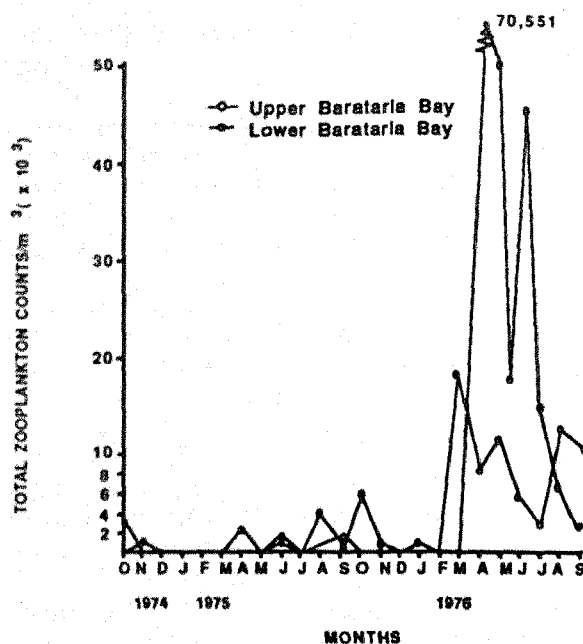


Figure 34. Monthly zooplankton counts from upper and lower Barataria Bay (Gillespie 1978).

taxa, identified by Bouchard and Turner (1976). Both nearshore and offshore locations exhibited similar zooplankton composition (Gillespie 1978). Both areas were dominated by the calanoid copepod, *Acartia tonsa*. Other copepods of importance were *Centropages hamatus*, *Eucalanus* sp., *Euchaeta marina*, *Eurytemora hirundoides*, *Labidocera aestiva*, *Paracalanus* sp., *Temora turbinata*, *Tortanus* sp., *Undinula vulgaris*, and *Halicyclops fosteri*.

Decapod larval stages were present throughout the year. Zoea and megalops of blue crabs were often abundant and were encountered throughout the year. The decapods, *Acetes americanus carolinae*, *Lucifer faxoni*, and *Leander tenuicornis* were often abundant.

A number of other holoplankters were encountered. *Noctiluca scintillans* was the most abundant protozoan encountered; however, Gillespie (1971) reported that protozoa did not appear to be a significant member of the zooplankton community along the surface waters of the Louisiana coast. Gillespie (1971, 1978) identified the chaetognath, *Sagitta hispida*, as being very common as well as the tunicate,

Oikopleura sp. Medusae were often present. The most common hydromedusae found along the Louisiana coastal samples were Liriope tetraphylla, Nemopsis bachei, and Obelia sp.

Meroplankton were also common members of the Barataria zooplankton. Annelid worms, predominantly polychaete larvae, were occasionally taken in plankton samples at different periods throughout the year. The most common polychaete larvae belonged to Nereis succinea. Small bivalve larvae were collected occasionally. Fish eggs and larval fish occurred throughout the year. In Gillespie's (1971) survey, the greatest numbers of fish eggs along the Louisiana coast were encountered in the coastal waters of the Barataria Basin.

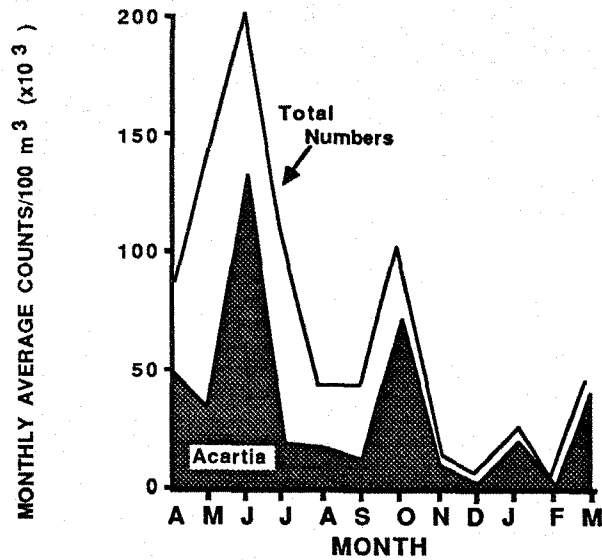


Figure 35. Monthly zooplankton for Barataria Bay with Acartia separated out for comparison (Gillespie 1971).

### 5.3 TEMPORAL VARIABILITY

Each habitat of the Barataria basin is characterized by a distinct seasonal zooplankton population pattern. Bouchard and Turner (1976) found only a winter peak of total zooplankton at their backswamp sampling location. Their freshwater and brackish locations were characterized by a fall population peak. Saltwater locations exhibited seasonally variable population peaks, with nearshore and offshore locations exhibiting peaks in the spring, fall, and winter. The data of Gillespie (1971) illustrates seasonal patterns for the higher salinity areas of the Barataria Basin (Figure 35). Total numbers fluctuate monthly, but minimum numbers occur during the winter months. The year to year variation is considerable (Figure 34).

The seasonal abundance of the major zooplankters for the different habitat types throughout Barataria Basin is presented in Figure 36. A. tonsa, the most numerous zooplankter, exhibited spring and fall reproductive peaks. Cyclopoid copepods and cladocera were most abundant in the fall. Late summer-early fall peaks were characteristic of brachyuran zoeae. Nauplii and rotifera showed no seasonality. Nauplii were abundant year-round, while rotifera were only present occasionally.

### 5.4 FACTORS AFFECTING ZOOPLANKTON DENSITIES

#### 5.4.1 Biological Factors

Bouchard and Turner (1976) found three important factors in the regulation of zooplankton densities: (1) predation by nekton and ctenophores, (2) duration of the larval stages of meroplankton, such as crab zoeae, shrimp, and fish larvae, and (3) changes in the aquatic environment brought by the populations themselves. Changes in zooplankton density can be directly correlated with the breeding cycles of the holoplanktonic copepods. Gonzalez (1957) found that the distribution of A. tonsa was, in all probability, affected by competition with other species. Distributional data on A. tonsa in the Barataria Basin indicates it thrives in areas of low salinities, even though it is remarkably adaptable to a wide range of salinities from 0.3 to 30 ppt. The lower salinities found in the basin probably limit competition from other copepods (Conover 1956; Cuzon du Rest 1963). Ctenophores can be the most important group of predators affecting zooplankton populations because of their extreme local abundance and voracious feeding habits. Bouchard and Turner (1976) and Gillespie (1978) found that the presence of ctenophores is usually

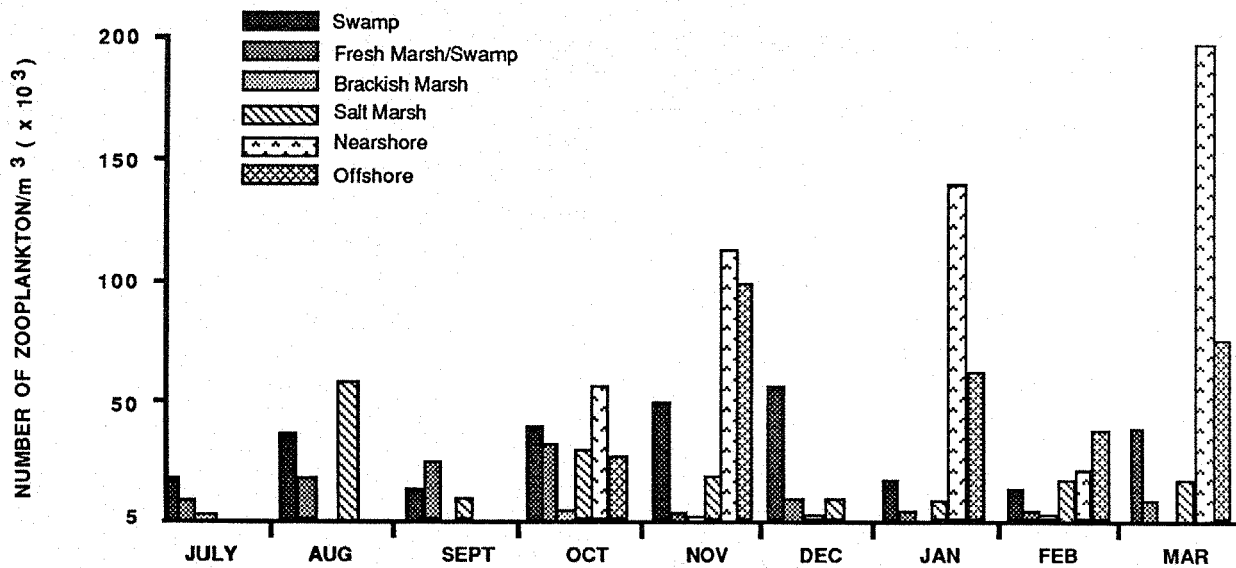


Figure 36. Seasonal abundance of zooplankton in different habitat types throughout the basin (Bouchard and Turner 1976).

accompanied by a decrease in the *A. tonsa* population.

#### 5.4.2 Physical Factors

Darnell (1962) noted that since the Barataria estuary is shallow, it is subject to great fluctuations in factors of the physical environment. The success of each zooplankter is dependent upon favorable conditions of salinity, turbidity, temperature, and other factors, reflected in such weather related phenomena as rainfall patterns, wind regimes, storms, hurricanes, floods and cold waves. Population peaks of different species usually follow in a succession determined by (1) external environmental conditions, and (2) changes that the populations themselves bring about in their environment. When nutrient levels are low, rates of reproduction and densities of organisms decline. At the same time, conditions become favorable for other species, and new populations appear (Ruttner 1968).

Gillespie (1978) found spring zooplankton peaks along the Louisiana coast were related to temperature. Lowest annual water temperatures coincided with lowest zooplankton counts. She further found that direct relationships between standing crops and salinity variations are not evident. Reproductive cycles of most of the

zooplankton species she encountered are apparently triggered by temperature. Gillespie (1971) found that salinity appeared to be the chief controlling factor in the number of species present, while temperature, competition, and predation control the number of individuals present.

Bouchard and Turner (1976) found that the distribution of zooplankton species is influenced largely by salinity, while the numbers of individuals are determined by other physical and biological parameters. Tidal flushing and constant inflow of freshwater carrying organic detritus and inorganic nutrients act on the numbers and species composition of estuarine zooplankton. River discharge, water depth, and tidal changes are examples of other physical factors affecting zooplankton populations. Turbidity and dissolved oxygen are the major chemical factors affecting zooplankton populations.

#### 5.5 FOOD HABITS

Zooplankton population levels follow peaks of food production. In most estuaries the zooplankters feed on phytoplankton (Peters 1968; DeNoux 1976) or ingest detritus or both (Darnell 1967). Most zooplankters are considered to be herbivorous filter feeders and will consume

any small suspended particulate material. Detritus is the most abundant suspended particulate material in the waters of the Barataria Bay and thus is probably a major food source (Day et al. 1973). In Louisiana waters the zooplankton peak coincides with a high rate of detrital loss from the

marshes due to tidal flushing and the constant inflow of freshwater carrying organic detritus and inorganic nutrients. There is a year-round supply of detritus in the waters of the Barataria Basin that could supply food to zooplankton populations (Day et al. 1973).

## CHAPTER 6

### BENTHOS

by

W.B. Sikora and F. H. Sklar

#### 6.1 BENTHIC SWAMP COMMUNITIES

##### 6.1.1 Introduction

Although more than one half of all the freshwater wetlands in the continental United States are located in Louisiana, almost all benthic studies have been in northern or saltwater wetlands (Crow and MacDonald 1978). It has only been within the last decade that synoptic surveys of Louisiana's swamp forests have revealed an abundant and highly complex invertebrate community (Bryan et al. 1976; Beck 1977; Ziser 1978; Sklar 1983). In the upper Barataria Basin, high population densities appear to be partially the result of high primary production, moderate flushing rates with a distinct hydrologic seasonality,

and the lack of osmotic stress from tidal inputs of salt. The types of macrobenthos which compose the freshwater swamps of Barataria, their habitat preferences, their temporal variability, and their possible trophic relationships will be discussed in this section.

##### 6.1.2 Distribution and Abundance

In a two year survey of three swamp sites of the upper Barataria Basin, Sklar (1983) identified 66 taxa of aquatic invertebrates (Table 11). Most of these animals were not routinely present; only a few dominated at any one time. There were 17 taxa of aquatic invertebrates that averaged over 100 individuals/m<sup>2</sup>, including two taxa of worms, one amphipod, and a dipteran which averaged, for

**Table 11.** Checklist of benthic organisms collected from the Lac des Allemands swamp from 1977 to 1979. Feeding types taken from Cummins (1973) and Wetzel (1975): FI=filter feeder, GA=gatherer, SC=scrapper, SH=shredder, and PR=predator. Standard error of the mean is given in parenthesis (N=144).

Taxa	Feeding type	Average individual weight (mg AFDW)	No./m <sup>2</sup>
Coelenterata			
Hydroidae			
Hydra sp.	FI	0.04	306.5 (100)
Turbellaria			
Tricladida			
Phagocata sp.	GA	0.46	66.8 (33)
Macrostomum sp.	GA	0.04	262.9 (84)



Table 11. Continued.

Taxa	Feeding type	Average individual weight (mg AFDW)	No./m <sup>2</sup>
Annelida			
Oligochaeta			
Naididae			
<u>Aulophorus vagus</u>	GA	0.07	2376.1 (317)
<u>Nais</u> sp.	GA	0.49	1622.3 (241)
Lumbricidae			
spp.	GA	23.14	46.2 (22)
Tubificidae			
spp.	GA	0.02	695.1 (250)
Hirudinea			
Rhynchobdellida			
<u>Nepheleopsis obscura</u>	PR	29.42	2.6 (1.1)
<u>Helobdella</u> sp.	PR	0.49	2.5 (1.9)
Arthropoda			
Crustacea			
Isopoda			
<u>Asellus obtusus</u>	GA	1.70	553.8 (189)
Amphipoda			
<u>Hyaella azteca</u>	GA	0.25	5337.0 (1209)
Decapoda			
<u>Procambarus clarkii</u>	PR	61.59	6.3 (3.3)
<u>Palaemonetes paludosus</u>	GA	24.86	3.8 (2.8)
Arachnida			
Hydracarina			
<u>Arrenurus</u> sp.	PR	0.03	12.3 (4.4)
Insecta			
Collembola			
<u>Isotomurus palustris</u>	GA	0.04	7.9 (2.9)
Ephemeroptera			
<u>Callibaetis</u> sp.	GA	0.25	43.1 (33)
<u>Caenis</u> sp.	SC	1.07	25.6 (14)
Odonata			
Zygoptera			
<u>Lestes</u> sp.	PR	3.04	17.1 (8.9)
<u>Enallagma</u> spp.	PR	3.04	65.5 (16)
Anisoptera			
<u>Leucorrhina</u> sp.	PR	21.00	4.8 (2.8)
<u>Erythemis</u> spp.	PR	21.00	28.7 (11)
Gomphidae			
<u>Libellula</u> sp.	PR	3.04	0.1 (0.1)
Hemiptera			
<u>Mesovelgia mulsanti</u>	PR	0.29	27.2 (6.4)
<u>Belostoma bakeri</u>	PR	29.24	4.5 (1.8)
<u>Neoplea striola</u>	PR	0.62	156.6 (67)
<u>Sigara grossolineata</u>	GA	0.93	0.5 (0.5)
<u>Gerris</u> sp.	PR	0.55	0.6 (0.6)
<u>Merragata hebroides</u>	PR	0.21	14.6 (9.2)
<u>Pelocoris</u> sp.	PR	4.91	5.1 (2.1)

Table 11. Continued.

Taxa	Feeding type	Average individual weight (mg AFDW)	No./m <sup>2</sup>
Homoptera			
Aphididae		0.04	
Neuroptera			
<u>Sialis</u> sp.	PR	1.23	1.8 (1.8)
<u>Chauliodes</u> sp.	PR	0.37	1.9 (1.1)
Lepidoptera			
<u>Neocataclysta</u> sp.	SH	0.6	150.8 (66)
Coleoptera			
<u>Hydroporus</u> sp. (larvae)	PR	0.43	11.6 (5.0)
<u>Hydroporus</u> sp. (adult)	PR	2.77	
<u>Dytiscus</u> sp.	PR	33.71	6.2 (2.9)
<u>Gyrinus</u> sp.	PR	2.17	2.3 (1.4)
<u>Hygrotus</u> sp. (larvae)	PR	0.43	8.4 (4.0)
<u>Hygrotus</u> sp. (adult)	PR	0.93	
Carabidae	PR	0.76	1.2 (0.9)
Staphylinidae	PR	0.75	0.5 (0.5)
<u>Lixellus</u> sp.	SH	0.93	2.1 (1.2)
<u>Tanysphyrus lemnae</u>	SH	0.33	12.6 (4.1)
<u>Peltodytes</u> sp.	PR	0.37	2.9 (1.8)
<u>Scirtus tibialis</u>	SH	0.55	10.3 (3.6)
<u>Hydrocanthus</u> sp. (larvae)	GA	0.43	4.8 (2.8)
<u>Hydrocanthus</u> sp. (adult)	GA	0.93	
<u>Hydrophilus</u>			
<u>H. tropisternus</u> (larvae)	PR	0.75	3.2 (1.6)
<u>H. tropisternus</u> (adult)	GA	4.90	
<u>H. triangularis</u> (larvae)	PR	0.75	6.8 (3.6)
<u>H. triangularis</u> (adult)	GA	4.91	
Elmidae	SC	0.93	0.6 (0.6)
<u>Tropisternus</u> sp.	PR	0.75	0.6 (0.6)
Diptera			
Chironomidae	GA	0.22	1767.9 (301)
Ceratopogonidae	PR	0.10	170.9 (87)
Tanypodinae	PR	0.19	490.2 (114)
<u>Chrysops</u> sp.	GA	0.49	52.5 (52)
Tipulidae	GA	0.71	3.7 (1.9)
Culicidae	GA	0.22	105.4 (41.8)
<u>Chaoborus</u> sp.	PR	0.21	62.1 (28)
<u>Odontomyia</u> sp.	GA	0.71	0.6 (0.6)
<u>Dolichopus</u> sp.	PR	0.93	3.1 (2.4)
Gastropoda			
Physidae			
<u>Physa sayi</u>	SC	0.08	71.5 (41)
<u>Physa integra</u>	SC	0.08	81.3 (24)
<u>Physa paludosa</u>	SC	0.08	4.9 (4.5)
Lymnaeidae			
<u>Lymnae</u> sp.	SC	0.02	8.0 (3.0)

Taxa	Feeding type	Average individual weight (mg AFDW)	No./m <sup>2</sup>
Planorbidae			
<u>Helisoma trivolvos</u>	SC	0.08	142.5 (57)
<u>Promenetus</u> sp.	SC	0.08	178.5 (84)
Anacylidae			
<u>Ferressia rivularis</u>	SC	0.08	313.5 (75)
Pelecypoda			
Sphaeriidae			
<u>Sphaerium partumeium</u>	FI	4.26	258.8 (83)

a 2-year period, over 1,000 individuals/m<sup>2</sup>. Forty-four percent of the taxa sampled averaged fewer than 10 individuals/m<sup>2</sup>.

During low runoff periods and in areas with little water exchange, the roots and leaves of floating macrophytes (Lemna minor, Spirodela

polyrhiza, Wolffia, and Wolffiella) act as substrates and food sources for backswamp benthic populations (Sklar 1983). The two backswamp habitats studied by Sklar (floating vegetation and sediment) were composed of many of the same taxonomic assemblages (Table 12). However, the floating vegetation population had significantly

Taxa	Sediment		Floating vegetation		ANOV (Pr>F)
	Number	%	Number	%	
Amphipoda	1,311	21.5	7,768	46.0	0.001 <sup>a</sup>
Collembola	6	0.1	7	0.1	0.840
Coleoptera	21	0.3	91	0.5	0.001 <sup>a</sup>
Decapoda	3	0.1	2	0.0	0.653
Diptera	1,000	16.4	2,409	14.3	0.003 <sup>a</sup>
Ephemeroptera	0	0.0	45	0.3	0.136
Gastropoda	118	1.9	854	5.1	0.001 <sup>a</sup>
Bivalvia	500	8.2	8	0.1	0.001 <sup>a</sup>
Hemiptera	13	0.2	174	1.0	0.001 <sup>a</sup>
Hydroidia	2	0.0	278	1.6	0.001 <sup>a</sup>
Isopoda	484	7.9	333	2.0	0.418
Lepidoptera	15	0.2	212	1.3	0.06
Neuroptera	2	0.0	7	1.0	0.12
Odonata	11	0.2	148	1.0	0.001 <sup>a</sup>
Oligochaeta	2,606	42.7	4,062	24.0	0.076
Rhynchobdellida	7	0.1	8	0.1	0.806
Tricladida	11	0.2	427	2.5	0.001 <sup>a</sup>
<b>Total</b>	<b>6,110</b>		<b>16,903</b>		<b>0.001<sup>a</sup></b>

<sup>a</sup>Highly significant.

greater densities of Amphipoda, Coleoptera, Diptera, Ephemeroptera, Gastropoda, Hemiptera, Hydroidia, Lepidoptera, Odonata, and Tricladida. Amphipoda composed 46% of the invertebrate assemblage in the floating vegetation but only 21% in the sediment. Oligochaeta exhibited the opposite trend: 42.7% of the bottom population were worms as compared to 24% in the floating population. Diptera composed almost equal proportions of the sediment and floating vegetation communities.

It is unknown just how important the floating macrophyte community is to the sediment community. Interactions between these two important swamp habitats needs to be investigated. However, according to Bryan et al. (1976), mats of floating vegetation act as great "rivers" of dispersal, depositing a variety of aquatic invertebrates over the rich forest floor. The community structure of the floating habitats lend support to this idea because many members of the floating macrophyte community are actually detritivores (i.e., flatworms, oligochaetes, insect larvae, and isopods), which are not generally considered water-column organisms.

The invertebrate communities associated with floating mats of duckweed in Barataria Basin are remarkably similar to those associated with floating water hyacinth mats (*Eichhornia crassipes*) in Florida. O'Hara (1967) identified 55 species of invertebrates associated with water hyacinth in Lake Okeechobee, Florida, of which 50% are the same as the ones in upper Barataria. Although water hyacinth has two to three times the root mass and surface area of duckweed, the density of the associated macrofauna in Florida water hyacinth was the same as that in Barataria duckweeds (16,484 individuals/m<sup>2</sup> and 16,903 individuals/m<sup>2</sup>, respectively). In Barataria, as in Lake Okeechobee, the floating macrophyte communities are dominated by the amphipod, *Hyaella azteca*. The importance of this organism is not clear; however, in Florida, Hansen et al. (1971) tagged water hyacinth with P<sup>32</sup> and found that *Hyaella azteca* was the major consumer of the floating vegetation and the dominant prey for some 70% of the aquatic animals.

The abundance of macrobenthos from the Lac des Allemands swamp in the upper Barataria Basin is greater than that found in a variety of other

aquatic habitats (Sklar 1983). Their likely importance as a food source for aquatic predators (Hansen et al. 1971; Platt 1981; Whitlatch 1981) in combination with their great abundance suggests that they have a significant influence upon the flow of carbon and nutrients through the swamp ecosystem. A recently developed computer model of benthic community dynamics (Sklar 1983) which traces the flow of organic carbon through the various aquatic components indicates that of the 1,269 g OM/m<sup>2</sup>/yr (gross primary production plus leaf fall) entering the aquatic community in a crawfish pond, only 186.5 g OM/m<sup>2</sup>/yr is exported. The rest is processed by the benthic communities and accumulated in the sediment.

### 6.1.3 Seasonality of Swamp Benthos

The seasonal distribution of macro-invertebrates from the swamp habitats in the upper basin is bimodal (Figure 37). There is an early summer peak and an autumn peak. The autumn peak decreases as cold weather sets in. Winter die-backs of floating vegetation greatly reduce benthic population sizes. As temperatures increase in the spring, densities of all benthos (i.e., floating and bottom) rapidly increase. Population densities decrease again in late summer in response to two factors; a hydrologic factor and a chemical factor.

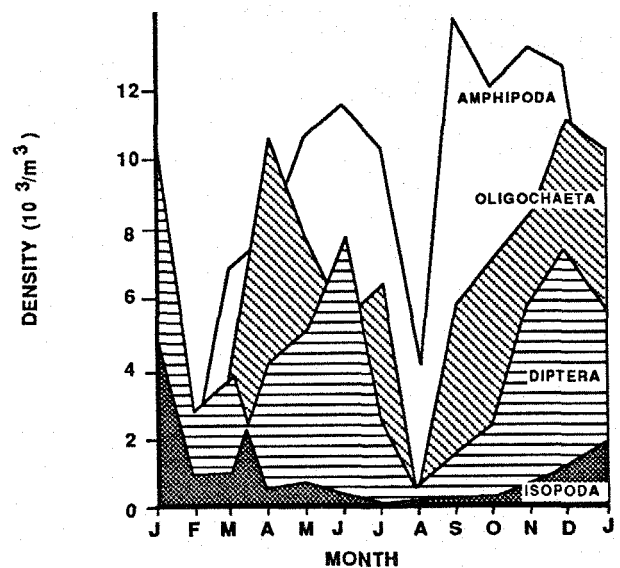


Figure 37. Seasonal density variations for the four most dominant taxa, all swamp sites combined (Sklar 1983).

Natural swamp hydrology results in a seasonal drying-out period from about June to September (Sklar 1983). This is a time when most of the aquatic organisms must either leave the backswamp areas and migrate towards the deeper bayous and canals or enter an estivation stage if they are to survive. Gastropods and crawfish, for example, dig down to the water table and remain there until the backswamps again become flooded. The life cycle of many aquatic insects will end at this time, but not before a new generation is deposited as eggs in the backswamp sediments. This hydrologic seasonality appears to be the most significant factor in the regulation of macroinvertebrate seasonality in the backswamp areas (Sklar 1983).

In backswamp areas that drain poorly as a result of canal dredging, anoxic conditions with the release of hydrogen sulfide can develop (McNamara 1978). Organic inputs from duckweed and leaf litter, high temperatures, and continuously flooded conditions in late summer combine to produce high respiration rates (McNamara 1978) and low oxygen levels (Kemp 1978). In response

to these biochemical factors, impounded swamp macroinvertebrate densities in the sediment drop to zero while populations in the floating duckweed mats are reduced by as much as 80% (Sklar 1983).

#### 6.1.4 Factors Affecting Swamp Benthos

Hydrologic differences between the three swamp sites in upper Barataria Bay have already been discussed (Chapter 4). The impact of these differences on the community structure of the swamp benthos was investigated by Sklar (1983) and is summarized in Figure 38. Invertebrate biomass in the floating vegetation of the impounded area was dominated by amphipods (3.0 g AFDW/m<sup>2</sup>), odonates (2.1 g AFDW/m<sup>2</sup>), and oligochaetes (0.9 g AFDW/m<sup>2</sup>), while the floating biomass of the natural and managed areas were, on the average, equally distributed among eight to ten taxa, ranging from a low of 0.1 g AFDW/m<sup>2</sup> to a high of 0.9 g AFDW/m<sup>2</sup> for any one taxa. Hydrologic management and constant water movement appears to have a profound effect on the invertebrate biomass in the sediment. The average invertebrate biomass in the sediments of

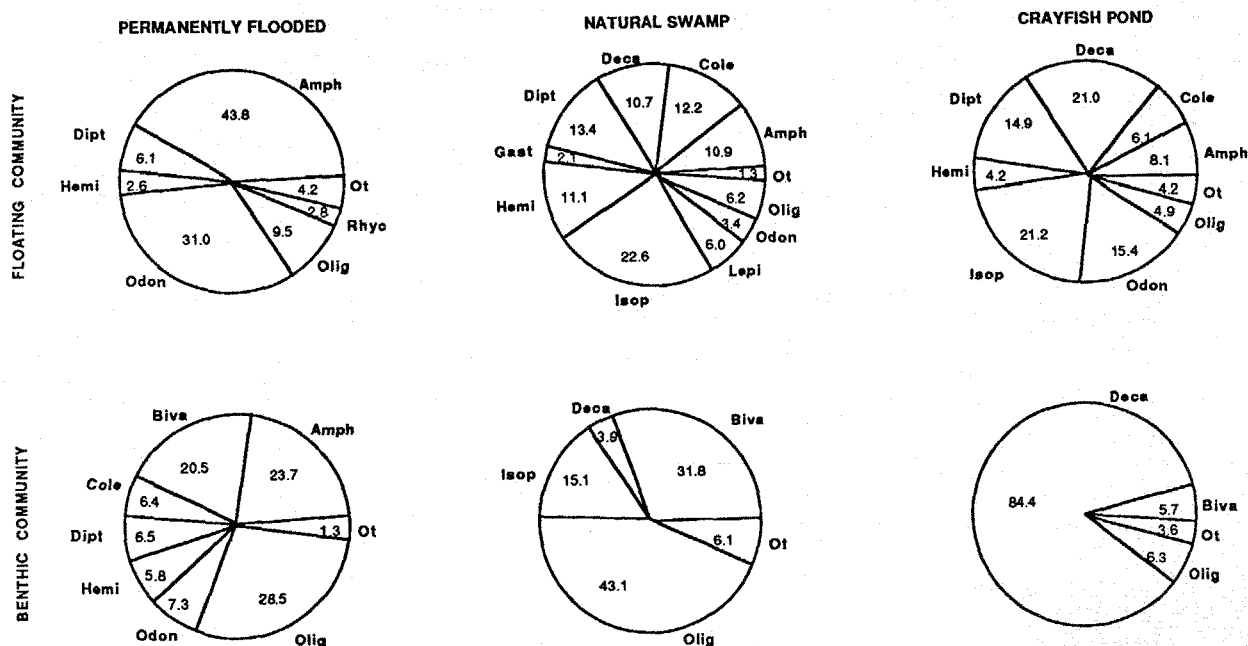


Figure 38. The proportion and average biomass (mg AFDW/m<sup>2</sup>) of the dominant benthic organisms by habitat in each swamp study site. Amph = Amphipoda, Dipt = Diptera, Deca = Decapoda, Hemi = Hemiptera, Odon = Odonata, Olig = Oligochaeta, Rhyc = Rhynchobdellia, Ot = Others, Gast = Gastropoda, Isop = Isopoda, Lepi = Lepidoptera, Cole = Coleoptera, Biva = Bivalvia.

the managed area was dominated by a crawfish (*Procambarus clarkii*) population with a higher standing biomass than any other taxa from any other habitat (9.6 g AFDW/m<sup>2</sup>). The control site sediments had high densities of oligochaetes, bivalves, and isopods (3.6 g AFDW/m<sup>2</sup>, 2.7 g AFDW/m<sup>2</sup>, and 1.3 g AFDW/m<sup>2</sup>, respectively). In contrast to the other two swamp areas, the invertebrate biomass in the impoundment sediments was composed of oligochaete, amphipod and bivalve populations with average biomass values not greater than 0.2 g AFDW/m<sup>2</sup>. Sklar and Conner (1983) hypothesize that these low sediment biomass values in the impounded swamps are a reflection of the anoxic stress these organisms must withstand to survive.

In backswamp environments, hydrology affects benthic community structure, in part, by regulating the physical environment in which the macroinvertebrates must live. For example, the biomass of floating duckweed vegetation in the impoundment was, on the average, almost four times that of areas with greater water exchange (Table 13). In response, the number of macroinvertebrates living in the floating mats of duckweed in the impounded swamp was also

greater. According to Sklar (1983), correlation coefficients ( $r=0.87 - 0.63$ ;  $P<0.01$ ) indicate that as floating substrate biomass increases, the density and diversity of the floating macrobenthos also increases. However, the macrobenthic organisms living in the sediment decline. The seasonally flooded swamp had the greatest density and the highest diversity of bottom dwelling organisms, followed by the crawfish farm. The impounded swamp sediment density averaged only 12.6% of the total water column density and had a significantly lower total macrobenthic diversity than the floating community. Thus, it appears that some floating vegetation enhances total benthic diversity but too much tends to indicate poor water and oxygen exchange, which decreases bottom sediment diversity. For aquatic macroinvertebrates, the impact of impounding a swamp is similar to lake eutrophication from organic or nutrient enrichment; diversity drops as density of the species remaining increases (Wilhm and Dorris 1966; Hart and Fuller 1974; Mann 1982). Without the flushing effects of sheet flow across the swamp sediments, organic matter accumulates, thick mats of floating macrophytes develop, water depth increases, and oxygen is depleted as temperatures rise during summer.

**Table 13.** Environmental differences among three swamp sites in Lac des Allemands with different water regimes. Tree data taken from Conner et al. (1981). All other data taken from Sklar (1983).

Parameter	Natural hydrologic regime	Impounded swamp with spoil banks	Crayfish farm <sup>a</sup>
Temperature (°C)	19.7	20.0	18.9
Depth (cm)	13.6	22.9	17.9
Net primary production (g/m <sup>2</sup> /yr)	1342.0	904.0	1936.0
Litterfall (gDW/m <sup>2</sup> /mo)	38.7	28.5	49.9
Total no. trees/ha	1303.0	1041.0	1564.0
Total basal area (m <sup>2</sup> /ha)	38.3	23.0	34.8
Floating macrophytes (gDW/m <sup>2</sup> )	68.7	97.1	25.1
Invertebrate biomass (gAFDW/m <sup>2</sup> )	12.6	7.7	14.7
Floating invertebrate (No./m <sup>2</sup> )	10,508.0	21,280.0	7708.0
Bottom invertebrate (No./m <sup>2</sup> )	5690.0	1715.0	2423.0
Total macrobenthic diversity	1.2	0.8	1.0

<sup>a</sup> Swamp with spoil bank and water control structures.

The increased energy needed by organisms to survive in such an environment could account for the significantly lower invertebrate biomass observed in the impoundment (Table 13).

### 6.1.5 Trophic and Ecological Relationships

Despite a greater density of prey in the impounded swamp area than in the natural or managed swamp sites, there were significantly fewer numbers and types of predators (Sklar 1983). Conspicuous by their absence or low densities were crayfish, Neuroptera larvae, giant water bugs (*Belostoma*), pigmy backswimmers (*Neoplea*), predacious diptera larvae, and numerous Coleoptera (whirligig beetles, predacious diving beetles, and water scavenger beetles). The prey/predator ratio in the impounded habitats averaged 32.3, while that in the seasonally flooded and crawfish farm sites averaged 19.2 and 8.0, respectively. This increase in the aquatic prey/predator ratio in the impounded habitats, relative to the other swamp areas, would indicate, as it would in a terrestrial

ecosystem, a shrinking up of available niche space (Hutchinson 1979) or what Wiens (1977) calls an "ecological crunch." In other words, the habitat is stressed and the top of the food-web is the most sensitive to the impacts.

The interconnectiveness and complexity of the trophic relationships of the benthic swamp community was recently described by Sklar (1983). A conceptual carbon flow model (Figure 39; Table 14) of trophic interactions in a natural, unimpacted swamp illustrates some of the major forcing functions, feedbacks, and material flows at the community level of aggregation. In this model, water level and flow can create an environment that stimulates duckweed production and regulates, in part, the immigration and emigration of all predators (vertebrate and invertebrate). The predators are, of course, also regulated by their own energetics, which are affected by the development of oxygen deficits (OD) in the water column, availability of prey, life and reproduction strategies, and migration between waterways and backswamp areas. Predator production is complicated by the

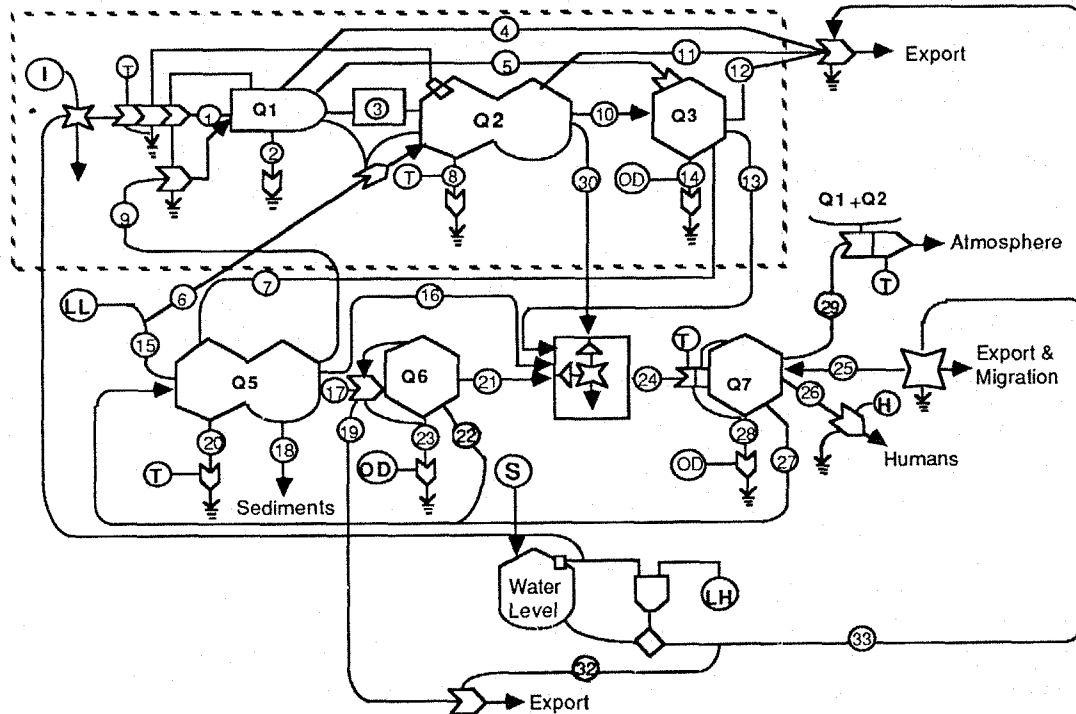


Figure 39. Conceptual model of backswamp steady state organic carbon flows in the Barataria swamp. For an explanation of the various components in the model, see Table 14 (Sklar 1983).

**Table 14.** Steady state variables, forcing functions, and organic flow averages for a natural backswamp. The flow number corresponds with those in Figure 39. State variables = g AFDW/m<sup>2</sup>; Flows = g AFDW/m<sup>2</sup>/yr.

Flow	Value	Comments and description
<b>State Variables</b>		
Q1	48.7	Live floating vegetation (a mixture of <u>Lemna</u> spp., <u>Spirodela</u> spp., <u>Wolffia</u> , and <u>Wolffiella</u> )
Q2	16.7	Dead floating vegetation and its associated microorganisms
Q3	3.1	Floating primary macroinvertebrates (herbivores and detritivores)
Q5	500	Microbenthic detrital community
Q6	10.7	Macrobenthic detrital consumers
Q7	2.1	Predators and omnivores (invertebrates)
<b>Forcing functions</b>		
LL	0.4	Litterfall (Conner et al. 1981; g OM/m <sup>2</sup> )
WL	5-500	Water level storage (mm) as a function of levee height (LH)
I	190	Solar insolation at the water surface (g-cal/m <sup>2</sup> )
T	13.4	Air and water temperature assumed equal (°C)
H	0	Commercial harvesting of crayfish
OD	1-0	Oxygen deficit index. A function of temperature and community respiration with time
S	3.65	Surplus rainfall with an appropriate runoff rate (from water budget)
LH	5-500	Levee height (mm)
<b>Average flows</b>		
1	664.4	Gross photosynthesis of duckweed as a function of light, backwater flooding, temperature, biomass, and the surface area available for growth (negative feedback from Q2)
2	326.9	Duckweed respiration
3	126.1	Accumulation of dead duckweed as floating detritus
4	97.4	Hydrologic export of live duckweed to waterways and downstream swamps as a function of runoff
5	141.8	Consumption of live duckweeds by herbivores
6	107.3	Accumulation of litterfall as floating detritus; a function of total water surface area covered by live and dead duckweed
7	113.4	Mortality of floating herbivores and detritivores; dead organisms become detritus in the sediments (Q5).
8	140.9	Respiration of microorganisms associated with floating detritus (Q2) as a function of substrate biomass and temperature
9	27.8	Uptake of dissolved organic matter by live duckweed (Q1)
10	47.3	Consumption of floating detritus and microorganisms by floating macroinvertebrate detritivores
11	33.4	Hydrologic export of live floating detritus community to waterways and downstream swamps as a function of runoff
12	6.2	Hydrologic export of live floating primary macroinvertebrates to waterways and downstream swamps as a function of runoff
13	12.4	Consumption of floating primary macroinvertebrates by predators and omnivores
14	56.9	Respiration of floating herbivores and detritivores as a function of oxygen in the water column and biomass



**Table 14. Concluded.**

Flow	Value	Comments and description
15	322.0	Accumulation of litterfall as benthic detritus
16	30.2	Consumption of benthic detritus and microorganisms by predators and omnivores
17	376.6	Consumption of benthic detritus and microorganisms by predators and omnivores
18	16.4	Peat accumulation
19	16.3	Hydrologic export of benthic detrital community to waterways and downstream swamps as a function of runoff
20	182.5	Respiration of benthic detrital microorganisms as a function of temperature
21	32.1	Consumption of benthic macroinvertebrate detritivores by predators and omnivores
22	188.3	Mortality of benthic macroinvertebrate detritivores; dead organisms become detritus in the sediments (Q5)
23	156.2	Respiration of benthic macroinvertebrate detritivores as a function of oxygen in the sediments and biomass
24	86.6	Total food consumption by predators and omnivores
25	3.2	Hydrologic export and predation of macroinvertebrate predators and omnivores as a function of water level
26	0	Crayfish harvest by humans
27	26.0	Mortality of macroinvertebrate predators and omnivores; dead organisms become detritus in the sediments (Q5)
28	54.2	Respiration of macroinvertebrate predators and omnivores as a function of oxygen in the water column and biomass
29	3.2	Insect emergence
30	11.8	Consumption of floating detritus and microorganisms by predators and omnivores
32	267	Backswamp drainage through breaks in levees and spoil banks (in mm)
33	250	Overland runoff as a function of levee height (mm)

fact that few organisms in the backswamp habitats are truly carnivorous throughout their lives (i.e., they aren't always predators). Thus, the model has an algorithm which allows predators to switch from one food source to another as a function of the age of the predators and the available food supplies.

This benthic swamp model illustrates other important ecologic characteristics including: (1) a negative feedback on floating macrophyte production as total floating biomass increases, (2) inputs of leaf litter (LL) into floating communities as floating biomass increases, (3) a significant detrital processing community composed of micro- and meiofauna (of which little is known), (4) macroinvertebrate communities primarily sustained by

consuming detritus and its associated fauna and flora, and (5) ecosystem exports dependent upon the interaction between swamp levee height (LH) and water level. Table 14 describes the state variables, forcing functions, and steady-state flows used to conceptualize the benthic dynamics in the backswamps of Barataria Basin.

The biology of the swamp floor can change as a function of hydrology, predator-prey interactions, and water chemistry (i.e., oxygen supply). The advantage of this model is its ability to simultaneously incorporate all three of these types of processes while simplifying the complex aquatic food web that exists in backswamp habitats. The end product is the ability to predict large scale alterations in population densities of floating

vegetation, detritus, and invertebrates (including commercially important animals, such as crayfish) as a function of management options or environmental contaminants. For example, the spraying of herbicides to maintain open waterways could be added to the model in order to investigate the herbicide's long-term effects on the herbivores which feed on (and control) the floating vegetation, as well as its potential to stress higher trophic consumers and alter the export of organic materials to downstream sites. A similar model developed by Sklar (1983) indicated that by lowering the levee height for an impounded swamp from 500 cm to 50 cm, there would be a 43% increase in the export rate of organic matter, a significant decrease in the stress caused by anoxic conditions, and a threefold increase in the quantity of benthic invertebrates.

## 6.2 BENTHIC ESTUARINE AND MARINE COMMUNITIES

### 6.2.1 Introduction

The relative ecological significance of the estuarine and marine benthic infauna is inversely related to depth of the water column. As the water column becomes progressively shallower from the edge of the Continental Shelf landward, the benthos become an increasingly more important component of the system. On the nearshore Continental Shelf and in the shallow coastal estuaries the benthos is a key component of the ecosystem, integrating the inputs from the water column and the land. At this productive land-sea interface the benthos affect and are affected by sediments, microbiota, detritus, nutrient cycles, plankton, and nekton.

The Barataria Basin is an important nursery area for a wide variety of fish and shell-fish, including many species of commercial importance (Chapter 7). In the gulf 97% of the commercially important species are estuarine dependent (Gunter 1967) and of these, all but menhaden are dependent on the benthic food web either directly or indirectly. Other important processes, such as nutrient cycling, are also regulated to a significant extent by the benthos. In a recently rediscovered aspect of benthic research, the coupling between water and sediments has been shown to be the dominating feature of Narragansett Bay nutrient dynamics (Kelly and Nixon 1984). The magnitude of primary nutrient deposition to the bottom

represents about 86% to 100% of the annual nitrogen and phosphorus loading to the bay; and at least 92% of this primary deposition of C, N, and P appears to return to overlying waters, mostly as remineralized inorganic nutrients (Kelly and Nixon 1984). This key role of coupling the water column and sediments by the benthos is now realized by estuarine and wetland scientists and is very likely to be a fundamental process in all estuarine systems.

Benthic infauna, by virtue of their low mobility and sedentary habits, serve as excellent biological indicators of environmental conditions. This aspect of the benthic community becomes even more significant when we consider the central role the benthos play in estuarine ecosystem processes. Despite their significance, however, the benthos remain one of the most difficult and costly components to study in the estuarine ecosystem. The complexity of the interactions in bottom communities is often overwhelming, the techniques for studying them are primitive, and the magnitude of effort required to successfully sample and analyze the benthos is enormous. For these reasons, the benthos often remain the least known and least understood component of most systems. This is true of the Barataria system also. There have been no large-scale comprehensive studies of the soft bottom benthos. The enormous size of the system is partially responsible for this.

The fauna of the Barataria system has been the subject of more continuous study than that of any other locality in the Gulf of Mexico (Dawson 1966). Numerous collections were made by personnel of the Louisiana State University Marine Laboratory on Grand Isle from 1928 to 1946. An extensive faunal list has been compiled by Behre (1950) covering many of the inshore forms. This list is incomplete with regard to the benthos, listing only two species of amphipods and five species of nonparasitic isopods. Polychaetes and mollusks occurring in the bay fare slightly better with more species being listed. The Marine Lab at Grand Isle was disbanded and the faunal list is generally not available.

During the late 1940's widespread oyster mortalities were thought to be related to the recent expansion of the oil and gas industry. A consortium of oil companies funded an extensive investigation in Barataria Bay and its surrounding

environs that became known as Texas A&M Research Foundation Project Nine. The voluminous mimeographed report was distributed to 28 depositories, most of which were marine laboratories (Mackin and Hopkins 1962a); however, it too is generally unavailable. The source material in this section is primarily published studies from Project Nine and more recent studies.

### 6.2.2 Physical Factors

As with any community in an ecosystem, the benthic community is affected by the physical factors in the environment. Such parameters as salinity, sediment type, and dissolved oxygen, along with other factors, affect the community to varying degrees. In shallow, estuarine systems very low oxygen conditions seldom persist long enough to substantially limit benthic communities. A series of 1,134 oxygen measurements were taken in 1948 from all parts of the greater Barataria Bay area (Jensen 1949 in Mackin and Hopkins 1962b). About 43% of all oxygen determinations fell between 5 and 6 ppm and only three titrations showed oxygen tension below 2 ppm, and none below 1.5 ppm. Only 24 determinations (2%) showed less than 50% saturation. Sediment type, as well as forces such as water current, can substantially change the composition of benthic communities. The problem of animal-sediment relationships has not been addressed in the Barataria Basin. Though the sediment has a far from homogenous grain size, the vast majority of water bottom in Barataria is a silty-clay sediment with varying amounts of detrital material. Krumbein and Aberdeen (1937) analyzed sediment from 98 stations in the lower Barataria Bay and reported that there were "shadow zones" of finer sediments at the edge of the main channel and behind many of the islands. Day et al. (1973) categorized the bottom sediments of Barataria only as soft peaty or muddy materials. Salinity appears to be a more important controlling factor than sediment type in determining bottom community composition in estuarine systems (Gunter 1961). There is a pronounced salinity gradient from the upper reaches of the system, which are fresh, to the passes which open to the Gulf of Mexico, where salinities are frequently over 30 ppt. Superimposed on this pattern of a north to south gradient there is often an east to west salinity gradient of varying duration (Mackin and Hopkins 1962b). Salinities can be substantially higher (up to 10 ppt) on the east side than on the west side at

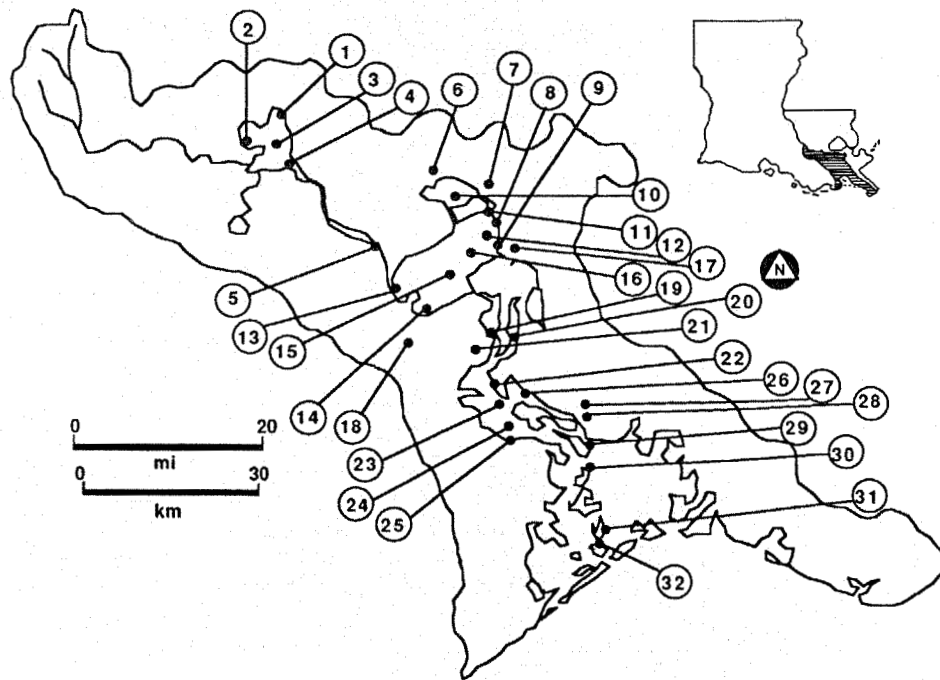
certain times, though the reverse can be true at other times (M. Chatry, LDWF, Grand Terre Laboratory; pers. comm.) This east-west, west-east gradient appears to be seasonal and may be influenced by the Mississippi River; however, the details of the phenomenon have not been studied extensively.

### 6.2.3 Open Water Habitats

One of the most ambitious efforts to study the benthos was that of Philomena (1983) in which a one-time transect was made of 32 stations from the upper reaches of the Barataria system to lower Barataria Bay in November 1978. Three of these stations were later sampled bimonthly from November 1978 to November 1979. Figure 40 shows a map of Philomena's stations and Table 15 gives the names and physical descriptions of the sampling locations. Based upon salinity, Philomena reported the biomass distribution of macrobenthos: freshwater, 64% (Stations 1 through 17); oligohaline, 23% (Stations 18 through 22); mesohaline, 0.5% (Stations 23 through 26); and polyhaline, 3.5% (Stations 23 through 32). Because there are only two polyhaline stations, the distribution of stations is skewed toward the freshwater side of the continuum.

Ninety-four different species were collected in the Barataria Basin in environments ranging from fresh to marine. A total of 254,813 organisms were collected from all 32 stations in November 1978. Numbers of taxa varied markedly from one station to the next. Overall, there was a mean of 10 species per station. When summarized at the level of higher taxonomic groups, crustaceans, polychaetes, oligochaetes, nematodes, and insects represented nearly 90% of all organisms.

The numerical density of the macrobenthic fauna is low in the lower basin and steadily increases to the upper basin. Patterns of high abundance can be identified in stations near the water's edge (Stations 2, 12, and 29) or in natural and shallow bayous (Stations 6, 7, 11, and 19), mostly in the freshwater areas. The largest number per square meter, 40,000 organisms, was found at Station 7 (Bayou Segnette); Gammarus mucronatus and several species of crustaceans contributed the most to these high densities. Abundance by weight (biomass in AFDW) yields a



**Figure 40.** Map of the Barataria Basin showing location of benthic sampling stations (Philomena 1983). See Table 15 for names of numbered stations.

different pattern from the numerical abundance caused by the enormous biomass of adult Rangia cuneata, which appeared in Stations 13, 14, 16, and 20.

Overall, crustaceans were the most numerically abundant group found in this survey, with 44 genera that contributed significantly in 94% of all stations and had 3% of the total biomass. The most important orders were Amphipoda, Cladocera, Ostracoda, and Isopoda.

Polychaetes, represented by 13 genera, appeared in 46% of all stations and had 1.5% of the total biomass. One species alone, Hobsonia florida (= Hypaniola florida), made up almost 40% of the total number of worms.

Mollusks with 18 genera appeared at 78% of all stations and represented 93% of the total biomass (mostly because of Rangia cuneata). Mollusks were numerically dominated by the gastropod, Texadina sphinctostoma, which accounted for 55% of the total number.

Oligochaetes were not classified at the generic level but were found in 60% of all stations. They represented only 0.5% of the total biomass and 14% of total numbers.

Insects accounted for a little more than 0.5% of the total biomass and 5% of total numbers. The insect assemblage was characterized mostly by chironomids, which made up 94% of all insects. Other groups, such as Turbellaria, Nemertea, Hydrozoa, Hirudinea, and Nematoda, were not so important in number or in weight.

A general comparison among stations revealed that freshwater habitats had a greater numerical abundance; abundance decreased as the habitat became more saline. Considering the whole basin and the most important groups, the overall spatial distribution of crustaceans and mollusks is basin-wide, while insects, nematodes (larger than 500 mm), and oligochaetes are distributed mostly in the fresh and intermediate habitats. Polychaetes and nemerteans were prevalent in brackish and marine environments.

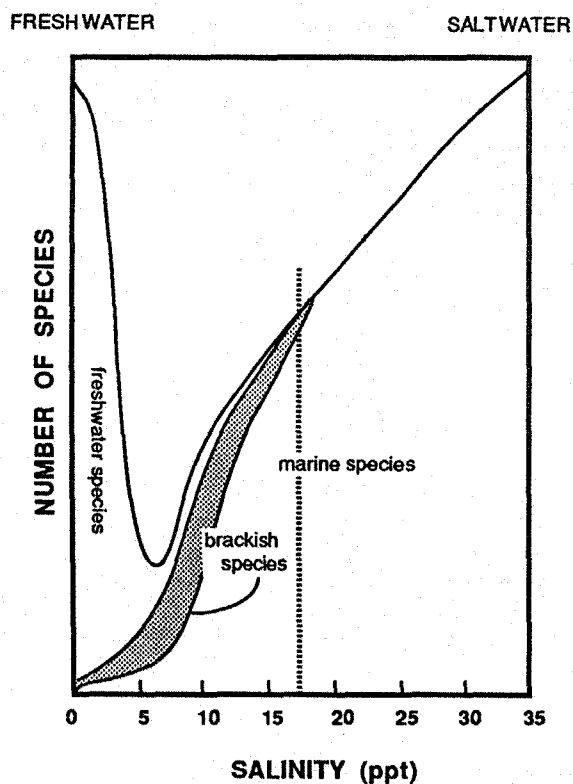
**Table 15. Environmental characteristics of benthic sampling stations (Philomena 1983).**

Station number	Name	Mean depth(m)	Habitat type	Salinity range (ppt) <sup>a</sup>	Habitat characteristic
1	Baie d'en Haut	1.0	Fresh	0.0	Open lake
2	Baie a Carlin	1.5	Fresh	0.0	Open lake
3	Middle Lake des Allemands	2.0	Fresh	0.0	Open lake
4	South Lake des Allemands	2.0	Fresh	0.0	Open lake
5	Bayou des Allemands	3.5	Fresh	0.0	Wide bayou
6	Bayou Verret	1.5	Fresh	0.0	Small bayou
7	Bayou Segnette	2.8	Fresh	0.0	Small bayou
8	Bayou Segnette Waterway North	2.0	Fresh	0.0	Open bayou
9	Bayou Segnette Waterway South	2.0	Fresh	0.0	Open bayou
10	Lake Cataouatche	2.5	Intermediate	0.0-1.0	Open lake
11	Bayou Bordeaux	3.5	Intermediate	0.0-2.0	Open bayou
12	Near-Shore Lake Salvador	2.2	Intermediate	0.0-1.0	Lake edge
13	Temple Bay	2.0	Intermediate	0.0-1.0	Open lake
14	Catahoula Bay	2.0	Intermediate	0.0-1.0	Open lake
15	SW Middle Lake Salvador	3.0	Intermediate	0.0-1.0	Open lake
16 <sup>b</sup>	Middle Lake Salvador	2.5	Intermediate	0.0-2.0	Open lake
17	Intracoastal Waterway	4.0	Intermediate	0.0-2.0	Open canal
18	Delta Farms	3.0	Fresh	0.5	Open lake
19	Bayou Perot	2.0	Intermediate	0.0-2.0	Open bayou
20	Bayou Rigolettes	1.5	Brackish	0.0-4.0	Open bayou
21	Sinuou Bayou	2.0	Brackish	0.0-4.0	Small bayou
22	Turtle Bay Canal	2.0	Brackish	2.0	Small canal
23 <sup>b</sup>	Little Lake	2.0	Brackish	0.0-11	Open lake
24	John the Fool Lake	1.0	Brackish	0.0-9.5	Lake edge
25	John the Fool Bayou	1.5	Brackish	3.0	Small bayou
26	Long Bay	1.0	Brackish	1.0-13	Shallow lake
27	Barataria Waterway	6.0	Saline	19.0	Deep canal
28	Barataria Waterway	8.0	Saline	19.0	Deep canal
29 <sup>b</sup>	Bayou St. Denis	2.0	Saline	2.0-20	Open bay
30	Barataria Bay	2.0	Saline	24.0	Open bay
31	Pelican Point	2.5	Saline	24.5	Open bay
32	Near Queen Bess Island	1.8	Saline	27.5	Open bay/ Near island

<sup>a</sup>Salinity measurements were sampled once in stations number 01, 02, 05, 22, 25, 27, 28, 30, 31, and 32.  
<sup>b</sup>Bimonthly Station.

Shannon-Weiner diversity distribution was suggestive of the species number versus salinity pattern of Remane (1934 in Pennak 1978; Figure 41), having high numbers of species in freshwater to oligosaline (0.0 to 5.0 ppt), lowest numbers of species for mesosaline areas (5.0 to 10.0 ppt), and

higher numbers of species towards the polysaline areas (10.0 to 36.0 ppt). Philomena's mean diversity values were approximately 1.64 for the freshwater to oligosaline areas (Stations 1 to 22), 1.135 for mesosaline areas (Stations 23 to 26), and 1.167 for polysaline areas (Stations 27 to 32).



**Figure 41.** The composition of the aquatic fauna in relation to salinity of the environment (reprinted, by permission, from Pennak 1978, copyright John Wiley and Sons, Inc.).

Another aspect of the spatial distribution of benthos is the comparison of open lake or bay versus bayous. In November 1978, Philomena (1983) sampled these habitats in a brackish water area and in a saline area. In the brackish water area, an open-lake station in Little Lake had an abundance of 4,448 organisms/m<sup>2</sup>, a lake-edge station in John the Fool Lake had an abundance of 1,757 organisms/m<sup>2</sup>, and a station in John-the-Fool Bayou had an abundance of 1,136 organisms/m<sup>2</sup>. In the saline area the pattern was reversed. An open bay station in Barataria Bay had an abundance of only 817 organisms/m<sup>2</sup> while a station in St. Denis Bayou had an abundance of 10,347 organisms/m<sup>2</sup>. The pattern is not clear, however. Philomena's samples were taken once in November with a single grab taken at each station, so the observed abundances could be the result of seasonal variations or patchiness of the benthos.

#### 6.2.4 Seasonal Patterns of Abundance

The patterns of benthic seasonal abundance in the Barataria system are not clear. Philomena (1983) sampled three stations bimonthly from November 1977 to November 1978. In Bayou St. Dennis, the southern-most station (mesohaline), he reported abundances at their lowest in March through May, then steadily rising to a peak abundance in September, declining somewhat in November. January abundance was lower than July abundance. At Little Lake, another mesohaline station, the lowest abundance was in March and the highest in November. In Lake Salvador (oligohaline) there were three low periods reported -- November, March and July -- and two peaks, January and May.

In Airplane Lake, in southwest Barataria Bay, Day et al. (1973) reported that the benthos, which was dominated by amphipods, reached the highest biomass levels during February and March and the lowest levels in May, June, July, and September. Thomas (1976) reported the abundance of benthic populations at a station 10 m from shore in Airplane Lake, from August 1972 to April 1973. Peak numbers occurred in February and March, and the lowest numbers in September. Burke (1976) studied the invertebrate fauna of the salt marsh in the vicinity of Airplane Lake and reported the highest numbers of amphipods occurred from June to October with a peak of 521 in August and a lowest number of 3 in February out of a total of 1,138 amphipods. Lindstedt (1978), in a study of epifaunal amphipods collected from frayed polyethylene rope samplers, reported the overall pattern of abundance of macrofauna near Leeville, Louisiana, and in the vicinity of Airplane Lake, generally showing a major peak in the spring and a minor peak in the fall with the lowest numbers collected during the winter. The benthic mollusks and crustaceans from seven stations in a neighboring system, Timbalier Bay, were studied by Farrell (1979) who reported a single peak in biomass in April. Also in a neighboring system, Sikora and Sikora (1985) studied the benthic community in a brackish water bayou (0-15 ppt) near Catfish Lake. Here the benthos exhibited two peaks in abundance, the largest in February and a slightly smaller peak in August.

Interpreting seasonal patterns from the above studies is made difficult because in only two

of the studies (Burke 1976; Lindstedt 1978) were samples taken on a monthly basis and then only for a single annual cycle. From the existing information, it appears that peak abundances and lowest abundances occur at different times in the different salinity regimes and may be correlated to the salinity pattern in a particular area or possibly to some extrinsic factor such as the migratory patterns of the estuarine dependent predators.

### 6.2.5 Crustacea

The crustacea are the most studied group of benthic invertebrates in the Barataria Basin. There are several reasons for studying this group: they are commonly occurring, easily collected, and more easily identified than other benthic groups. The results of five studies are listed and compared in Table 16. The amphipods appear to be the most

**Table 16.** Summary table of Crustacea<sup>a</sup> reported from the Barataria system by author.

Species	Philomena 1983	Thomas 1975	Lindstedt 1978	Burke 1976	Gillespie 1969
<b>Amphipoda</b>					
<u>Ampelisca abdita</u>	X	X	X	X	
<u>Atylus</u> sp. (= <u>Nototropis</u> )	X	X			
<u>Caprella equilibra</u>			X		
<u>Cerapus benthophilis</u>	X	X	X		
<u>Corophium lacustre</u>	X				
<u>Corophium louisianum</u>	X	X	X	X	
<u>Cranogonyx obliquus</u>		X			
<u>Cranogonyx pseudogracillus</u>		X			
<u>Gammarus</u> sp.	X	X			
<u>Gammarus mucronatus</u>	X	X	X	X	
<u>Gammarus tigrinus</u>	X	X	X		
<u>Gitanopsis</u> cf. <sup>b</sup> <u>tortugue</u>		X	X		
<u>Grandidierella bonnieroides</u>	X	X	X		
<u>Haustorius</u> sp.		X			
<u>Hyaella azteca</u>	X	X			
<u>Melita nitida</u>	X	X	X	X	
<u>Monoculodes edwardsi</u>	X				
<u>Microprotopus raneyi</u>	X				
<u>Microprotopus shoemakeri</u>		X			
<u>Orchestia</u> sp.		X			
<u>Orchestia grillus</u>		X	X	X	
<u>Orchestia platensis</u>		X			
<u>Parhyale hawaiiensis</u>		X		X	
<u>Sycheidium</u> sp.		X			
<u>Talorchestia</u> sp.		X			
<b>Isopoda</b>					
<u>Ancinus depressus</u>					X
<u>Cassidinidea ovalis</u> (= <u>C. lunifrons</u> )		X	X		
<u>Chiridotea coeca</u>		X	X		
<u>Cleantis planicauda</u>					X
<u>Cyathura polita</u>	X				
<u>Edota montosa</u>	X	X	X		X
<u>Ligia exotica</u>					X

Table 16. Concluded.

Species	Philomena 1983	Thomas 1975	Lindstedt 1978	Burke 1976	Gillespie 1969
<u>Munna reynoldsi</u>	X				
<u>Sphaeroma quadridentatum</u>		X	X	X	X
<u>Synidotea</u> sp.					X
Cumacea					
<u>Cyclaspis</u> A (undescribed sp.)	X				
<u>Cyclaspis</u> B (undescribed sp.)	X				
<u>Leucon</u> sp. (undescribed sp.)	X				
<u>Oxyurostylus smithi</u>	X				
Mysidacea					
<u>Bowmaniella dissimilis</u>		X			
<u>Metamysidopsis swifti</u>		X			
<u>Mysidopsis almyra</u>	X	X			
<u>Mysidopsis bahia</u>	X				
<u>Taphromysis louisianae</u>		X			
Decapoda					
<u>Alpheus</u> sp.			X		
<u>Eurypanopeus depressus</u>				X	
<u>Hexapanopeus angustifrons</u>	X				
<u>Neopanope texana</u>	X				
<u>Menippe mercenaria</u>			X		
<u>Panopeus herbstii</u>			X	X	
<u>Pagurus</u> sp.			X		
<u>Rhithropanopeus harrisii</u>	X			X	
Tanaidacea					
<u>Hageria (=Leptocheilia) rapax</u>	X	X	X	X	

<sup>a</sup>Excluding Cirripedia, Cladocera, Ostracoda.  
<sup>b</sup>cf. abbreviation for confer, to be compared to; compare. Used when a species determination is not certain but compares closely with a described species.

numerous in terms of species and individuals and are also one of the more important groups bionomically, serving as food for many species of fish. Thomas (1975) reports 17 species of amphipods as commonly occurring, with four additional species as single occurrences. Thomas and Heard (1979) described a new tube-building amphipod, Cerapus benthophilus, as constructing extensive mats of interwoven tubes that dominate the bottom in many low and intermediate salinity areas that are subject to current flow. Another common tube-builder, Ampelisca abdita, occurs in the same areas as C. benthophilus, but on muddy bottoms with little or no current.

Lindstedt (1978) observed the macro-benthic epifaunal community that settled on frayed

polypropylene rope collectors set out near the natural edge of marshes in a control area near Airplane Lake and disturbed edges of spoil banks in the Leeville oil field, an active oil extraction site. The assemblage that settled in the collectors was dominated by the amphipods Gammarus mucronatus, Corophium louisianum, Grandidierella bonnieroides, Caprella equilibra, Melita nitida, and Gitanopsis tortuque. The amphipods made up an annual mean of 86% of a mean of 1,187 total organisms while the rest of the assemblage contained 22 other crustacean taxa and twelve other invertebrate taxa not identified beyond the class level. Oil extraction and associated activities such as canal dredging and spoil bank construction had an adverse impact, reducing the annual mean number of amphipods by 72% and



reducing the annual mean of the total organisms collected by 68%. Reduced numbers of both tube-building and non-tube-building amphipods were observed in the oil field.

Gut analysis has shown that amphipods are frequently ingested food items in a number of fish in Louisiana. Thomas (1975) found that the three most abundant fish collected during his study, the bay anchovy (Anchoa mitchilli), Atlantic croaker (Micropogonias undulatus), and the sheepshead minnow (Cyprinodon variegatus) all used amphipods in the following order of abundance: Grandidierella bonnieroides, Corophium louisianum, Melita nitida, Gammarus mucronatus, and Ampelisca abdita. Amphipods appear to be consistent food items of juvenile Atlantic croaker (Overstreet and Heard 1978; Levine 1980).

#### 6.2.6 Meiofauna

The meiofauna of open water stations in Airplane Lake were studied by Rogers (1970). It is difficult, however, to draw any detailed conclusions from this sampling study because a nonstandard subsampling technique (aqueous aliquoting) was used, samples were not stained before sorting, and there was a general lack of statistics. Samples were taken six times during February through August at inshore stations, at unspecified distances from shore (called "in" stations), and further out from shore an unspecified distance (called "out" stations). Nematode numbers dominated all stations at all six sampling times. The highest abundance occurred in March and the lowest abundance in August. The number of nematodes ranged from 0.685 to  $4.165 \times 10^6/m^2$ . The "in" stations were consistently higher in numbers of nematodes in samples except in July when the pattern was reversed with the "out" stations being higher. The low numbers of meiofauna in the summer agree with two other unpublished studies (cited by Day et al. 1973), one of which described marsh meiofauna and the other described meiofauna of open water sediments in Airplane Lake. The biomass of individual nematodes from Airplane Lake has been estimated as 0.000269 mg/nematode (Day et al. 1973); this value is an order of magnitude smaller than reported from Buzzards Bay, Massachusetts (0.0012 to 0.0041 mg/nematode; Wisner 1960).

#### 6.2.7 Oyster Community

A major benthic community in many of Louisiana's estuaries is formed by Crassostrea virginica, the American oyster. The associated fauna of oyster communities in Barataria Bay have been listed by Mackin and Hopkins (1962a) and by Mackin and Sparks (1962). In Barataria Bay and Little Lake, according to the most recent information available (P. Bowman, Louisiana Department of Wildlife and Fisheries; pers. comm.), the area of commercial production (estimated by the total area of oyster leases) totaled 4,898 ha in 1975 (Van Sickle et al. 1976). The Barataria system historically has not been noted for extensive natural oyster reefs. Early surveys of natural oyster reefs by Moore (1899), Cary (1907), and Payne (1912) do not mention reefs occurring in the Barataria Basin (reviewed by Mackin and Hopkins 1962b). Mackin and Hopkins (1962b) state that "before the turn of the century (Moore 1899), bays like Barataria and Terrebonne reportedly contained only relict reefs," although Krumbeyn and Aberdeen (1937) mention many slightly submerged oyster reefs. Although large oyster populations do exist in the Barataria system, the size of these aggregations is smaller than would constitute a reef by Moore's size criterion (84 m<sup>2</sup>). Historically, it has been established that oyster mortality rates are higher in lower Barataria Bay than in the upper reaches of the bay (Mackin and Hopkins 1962a). Mortality rates are the highest during the summer months and various explanations have been advanced, including lowered oxygen, turbidity or the lack of turbidity, and higher salinities. Hopkins concluded that heavy summer mortalities in Barataria Bay probably started as far back as 1939; however, he also observed that other animals of the oyster community did not suffer these unusual mortalities. Mackin and Hopkins (1962b) advanced the hypothesis that higher salinities and summer temperatures favor oyster predators such as the conch (Thais haemastoma) and the stone crab (Menippe mercenaria), competitors such as the sea squirt (Mogula manhattensis), shell parasites such as the boring sponge (Cliona celata) and the boring clam (Diplothyra smithii (= Martesia smithii)), and disease-producing parasites such as the protozoan Perkinsus marinus. Table 17 lists the benthos associated with oysters in Barataria by salinity regime (from Mackin and Hopkins 1962b). Under these combined pressures, it was theorized that the population of older, mature oysters

**Table 17. Salinity relations of some common animals on Louisiana oyster beds (modified from Mackin and Hopkins 1962b).**

**High-salinity species**

Cliona celata Grant, sulphur sponge, boring sponge  
Haliclona sp., encrusting sponge  
Astrangia astreiformis Milne Edwards and Haime, solitary coral  
Mercenaria sp. clam  
Diplothyra smithii Tyron, shell-boring clam  
Doridella obscura Verrill, nudibranch, sea slug  
Crepidula plana Say, flat slipper limpet  
Thais haemastoma haysae Clench, conch, oyster drill  
Anachis avara Say, greedy dove shell, A. obesa (Adams), fat dove shell  
Nassarius vibex (Say), mud snail  
Hydroides dianthus (Verrill), calcareous tube worm  
Clibanarius vittatus (Milne Edwards), A. heterochaelis(Say), pistol shrimps  
Alpheus armillatus Milne Edwards  
Menippe mercenaria (Say), stone crab  
Callinectes danae Smith, little blue crab  
Molgula manhattensis (Dekay), sea squirt

**Species more or less independent of salinity**

Cliona truitii Old, small boring sponge  
 Sea anemones (including Aiptasiomorpha texaensis Calgren and Hedgpeth)  
Stylochus ellipticu (Girard), flatworm  
Bugula neritina (Linn.), bryozoan (species not certain)  
Membranipora sp., encrusting bryozoan  
Polydora websteri, Hartman, mudworm  
Spiochaetopterus oculus Webster, tube worm  
 Nereids (probably including Nereis pelagica occidentalis Hartman and Neanthes succinea (Frey and Leuckart))  
Odostomia impressa Say, parasitic snail  
Balanus spp. (including B. eburneus Gould and probably B. improvisus Darwin), barnacle  
Palaemonetes spp. (including P. vulgaris and P. pugio, certainly, and possibly P. intermedius), grass shrimp  
 Unidentified gammarid amphipods  
Corophium lacustre Vanhoffen, C. louisianum Shoemaker, mud tube amphipods  
Callinectes sapidus Rathbun, blue crab  
Eurypanopeus depressus (Smith), mud crab  
Panopeus herbstii Milne Edwards, mud crab  
Opsanus beta (Goode and Bean), oyster dog, toadfish  
Gobiosox strumosus Cope, sucker fish  
Gobiosoma bosci (Lacépède), goby  
Hypsoblennius iothas (Jordan and Gilbert), blenny

**Low-salinity species**

Ischadium recurvum (Rafinesque), hooked mussel  
Mytilopsis leucophaeata (Conrad), Conrad's false mussel  
Rangia cuneata (Sowerby), Common rangia  
Neritina usnea (Röding) (= N. reclinata Say), brackish water snail

collapses in Barataria Bay during the summer with the result that only intertidal populations survive in the bay.

Oyster mortality may occur, however, in areas relatively free of predators, competitors, and shell parasites. The sole culprit in these instances appears to be the protozoan Perkinsus marinus. P. marinus was originally described as a "protistan" (Dermocystidium marinum; Mackin et al. 1950a) but was later thought to be allied to another protistan group (Labyrinthomyxa marina) by Mackin and Ray (1966). From electron microscope examination, L. marina was thought to be allied with the fungi (Perkins 1969). With more complete electron microscope examination of the "zoospores," however, it was placed in a new genus (Perkinsus), a new family, a new order, and a new class in the protozoan phylum (Apicomplexa) by Levine (1978), a group that also contains malaria and cercaria parasites. It is still referred to colloquially as "Dermo." Mackin (1962) experimentally found that infection by P. marinus is usually lethal to the host oyster during high temperature periods and that "temperature directly controls the development of epizootics which reach their apex in the summer or early fall." Consequently, this disease is responsible for the majority of mass oyster mortalities in the summer months. This pathogen is probably the major cause of unusual, widespread mortalities of oysters in Louisiana (Van Sickle et al. 1976); however, it also occurs in Florida and the Chesapeake Bay Estuary (Perkins 1969).

In Louisiana, there has been a long established theme that high salinity water is detrimental and that "salt water intrusion" is the worst of the natural disasters to befall the Louisiana coast. Early in this century (Cary 1907), high salinity was implicated in instances of oyster mortality. Reports of the Louisiana Conservation Commission returned repeatedly to the theme that high salinity and high oyster mortality were correlated (Alexander 1922; Payne 1920). Despite this, oysters in Louisiana grow faster, spawn more prolifically, and set in larger numbers in high salinity waters of up to oceanic salinity concentrations (Mackin and Hopkins 1962b). It appears that much of the folklore about the evils of high salinity and salt water intrusion began with oyster mortalities which may in fact be caused by the presence of the endemic, virulent oyster pathogen P. marinus. Because of this pathogen,

the planting or bedding industry developed. Commercial production of oysters in Barataria Bay is primarily accomplished by bedding seed oysters in the fall and harvesting by late spring or early summer, before temperatures rise to the lethal level.

#### 6.2.8 Discussion

The information available on the benthos of the Barataria Basin is incomplete, leaving the benthos as one of the least understood components of this estuary. There have been no studies comparing the overall community composition in the major salinity regimes of the system. Information is also lacking as to whether open water areas such as bay bottoms differ significantly from bayous. The spatial distribution patterns from shore to open water and from bank to bank in bayous is also lacking. Most importantly, the seasonal composition, abundance, and distribution remains poorly understood. There has been much confusion regarding the apparent seasonal abundance of benthos being lower in summer and higher in winter, leading to speculation about low oxygen in the warmer months. Much of this speculation may stem from results of studies in freshwater ponds and lakes where summer stratification and complete oxygen depletion in bottom waters are common. However, in shallow, tidally-mixed systems where wind is often the predominant force, oxygen depletion to the point of defaunation is unlikely, except in stagnant, dead-end access canals (Sikora and Sikora 1985).

Benthic populations in shallow estuarine systems are probably controlled by factors such as salinity and the seasonal influxes of predators commonly referred to as estuarine dependent species. It has been well known that estuaries are nursery grounds for these species. The food of juvenile estuarine dependent species while they are in the nursery grounds has been a major point of confusion. The traditional view has been that the refractory material referred to as vascular plant detritus, or just "detritus," serves as the principal food source. Overlooked is the fact that most metazoans lack the enzymes to use detritus as a primary food source directly. The rapid growth rates of the migrant nursery ground species preclude detritus as the primary food source for animals this size, even if they did have enzymes that could break it down. Symbiosis such as that

found in ruminants has not been demonstrated in any of these marine species. The food source with the highest potential nutritive value to rapidly growing nursery ground species is the biomass of the benthos. These animals represent the concentration of energy from the detritus food base which has passed through one to several trophic levels beginning with the microbes, the primary detritivores. Many food habit studies have shown that benthos are the primary food of the majority of migrant nursery ground species.

The comparison of the abundance distribution with the biomass distribution of benthic organisms in Barataria Basin is quite interesting (Table 18). Crustaceans and polychaetes together comprise 57% of the total number of organisms collected at 32 stations in November 1978 by Philomena (1983). Despite the fact that these two groups are widely distributed, exhibit a high degree of fidelity among the stations, and are important food items, together they only account for 4.5% of the biomass. Mollusks on the other hand, comprise only 1.9% of the total number of individuals collected but account for 93% of the biomass. Most of the molluscan biomass was found as large *Rangia cuneata* of 29 to 48 mm (mean size) in Lake Salvador and Little Lake. Although Philomena's survey was not comprehensive, with major communities such as the oyster community omitted, it would still be safe to say that the benthic biomass in the Barataria estuary is mollusk dominated. This lopsided

biomass distribution may be the result of the larger *Rangia* escaping predation by virtue of their size and location. Standing crop biomass was found by Philomena to average 105 g AFDW/m<sup>2</sup> in Lake Salvador, 40 g AFDW/m<sup>2</sup> in Little Lake and 3.0 g AFDW/m<sup>2</sup> in Bayou St. Denis or a mean of 49.3 g AFDW/m<sup>2</sup> for these three areas.

Philomena's transect from the freshwater areas of the upper reaches to the polysaline lower Barataria Bay emphasized only the most salient features of the estuary, its large size, and the great distance from the swamp to the gulf. As a result of this size, the brackish water area has been enlarged horizontally, and it has long been known that brackish waters are poor in number of species. Remane and Schlieper (1971) refer to this phenomenon as "species impoverishment" and for many estuaries, this situation has been found to occur between 5 to 7 ppt. It is displaced towards the freshwater end of the spectrum as illustrated in Figure 41. Also, Remane and Schlieper stated that the effect is most pronounced in the benthic macrofauna as opposed to the microfauna and more generally pronounced in groups forming a calcareous skeleton than those lacking a calcareous skeleton. Philomena's Stations 1 to 22 are freshwater to oligohaline, Stations 23 to 26 are mesohaline or brackish, and Stations 27 to 32 are polyhaline. Philomena's mean number of species versus salinity (10.5, 7.5, and 7.1 for fresh-oligohaline, mesohaline, and polysaline, respectively) does not support this relationship, however. Conversely, the mean number of individuals (9,608, 2,093, and 3,730/m<sup>2</sup> for fresh-oligohaline, mesohaline, and polyhaline, respectively) does appear suggestive of Remane's species/salinity relationship as does the mean Shannon-Wiener diversities mentioned above. These data, however, may be artifacts because of the disparity in the large number (22) of fresh-oligohaline stations versus the number of mesohaline stations (4) and polyhaline stations (6). In addition, other factors such as predation have to be considered.

Much more research is necessary to fully understand the dynamics of complex systems such as the Barataria Bay. The distribution and abundance of the benthos can not be viewed in isolation from the rest of the system. Predation on soft-sediment estuarine benthic communities in vegetated portions of estuaries and lagoons can be quite severe. Peterson (1979) cited 11

**Table 18.** Comparison of major benthic taxa in abundance (percent compositions) vs. percent biomass, all organisms collected at all stations in November 1978 by Philomena (1983).

Taxa	%Abundance	%Biomass
Crustacea	34.0	3.0
Polychaeta	23.0	1.5
Oligochaeta	14.0	0.5
Nematoda	13.0	—
Insecta	5.0	0.5
Mollusca	1.9	93.0
Turbellaria	2.0	1.5
Nemertea	2.0	1.5
others	5.1	1.5

studies, beginning with Blegvad (1928), in which large epibenthic predators were successfully excluded from soft sediment marine benthic communities. Without exception, the density of macroinvertebrates was significantly higher inside exclusion cages than in control areas. In nine studies, the density and biomass of the benthos increased significantly inside the cages compared to the controls, and in two of the studies, the density inside the cages remained nearly constant while the density in the controls decreased significantly. Soft sediment systems, when freed from predation usually exhibit an increase in total number of organisms per unit area, an increase in species richness, and no tendency toward competitive exclusion by some dominant species inside the cages. Length of time to community equilibrium is certainly a factor, but in eight of the studies cited by Peterson, the length of the experiment was 6 to 14 months, and in one experiment, 24 months. These results all indicate that predation is the major controlling factor in estuarine soft-sediment communities. The seasonal fluctuations in soft sediments observed in the Barataria system at some locations appear to be counterintuitive in that peak abundances occur in winter when metabolic and reproductive rates should have been slowed by lower temperatures. There remain many questions to be answered concerning the community structure of the benthos in the Barataria system.

At present the benthic fauna is still largely unknown. The most extensive study in terms of

area sampled in the Barataria system was that of Philomena (1983). He recorded 97 species from 32 stations, 28 of which were located in middle and upper reaches of the system with only four stations located in the more saline Barataria Bay. In neighboring Timbalier Bay, Farrell (1979) recorded 55 species of crustaceans and mollusk alone, and Kritzler (1979) recorded 82 species of polychaetes from four common stations in the bay, yielding a total of 137 species for these three groups. That Philomena's total of 94 species is conservative can be seen from Table 16 which lists six major groups of crustaceans including 28 additional species not encountered by Philomena but recorded by four other studies. The need to fill in necessary details in the Barataria system still remains.

There are occasions when a small detail, like the presence of a single species, can change major components of ecosystems and how they function. In Barataria Basin, high salinities and salt water intrusion have been blamed for oyster mortalities for over half a century. Perhaps much of the folklore about the destruction of the system wrought by salt water stems from early incomplete observations. Most of the observed mortalities appear to be caused by a single organism, Perkinsus marinus in combination with the physical factors of high salinity and high temperatures. There remains a great need for continued basic research into the structure and function of the benthos in the Barataria system.

## CHAPTER 7

### NEKTON

by

B.A. Thompson and W. Forman

#### 7.1 INTRODUCTION

In ecological studies, nekton comprises those organisms that can actively swim independent of current movements. In the Barataria Basin, this group comprises numerous fishes; invertebrates such as squids, portunid crabs, and penaeid shrimps; and marine mammals like bottlenose dolphins. Most of those species are a part of the planktonic community for the early

stages of their life cycle, eventually becoming nektonic or occasionally sedentary in later stages.

Major studies on the nekton in the Barataria Basin include Forman (1968), Perret et al. (1971), Ruebsamen (1972), Jaworski (1972), Wagner (1973), Sabins and Truesdale (1974), Barrett et al. (1978), Simoneaux (1979), Rogers (1979), Allen (1979), Chambers (1980), and Guillory (1982). Table 19 presents a summary

**Table 19.** Ecological classification of fishes recorded in the Barataria Basin.

#### FRESHWATER (31 species)

Acipenseridae	
<u>Acipenser oxyrinchus</u>	Atlantic sturgeon
Lepisosteidae	
<u>Lepisosteus oculatus</u>	Spotted gar
<u>L. osseus</u>	Longnose gar
<u>L. spatula</u>	Alligator gar
Amiidae	
<u>Amia calva</u>	Bowfin
Clupeidae	
<u>Alosa alabamae</u>	Alabama shad
<u>A. chrysochloris</u>	Skipjack herring
<u>Dorosoma cepedianum</u>	Gizzard shad
<u>D. petenense</u>	Threadfin shad
Esocidae	
<u>Esox niger</u>	Chain pickerel
Cyprinidae	
<u>Notemigonus crysoleucas</u>	Golden shiner
Ictaluridae	
<u>Ictalurus furcatus</u>	Blue catfish
<u>I. punctatus</u>	Channel catfish
<u>Pylodictis olivaris</u>	Flathead catfish

Table 19. Continued.

Aphredoderidae	
<u>Aphredoderus sayanus</u>	Pirate perch
Poeciliidae	
<u>Gambusia affinis</u>	Mosquitofish
<u>Heterandria formosa</u>	Least killifish
<u>Poecilia latipinna</u>	Sailfin molly
Percichthyidae	
<u>Morone mississippiensis</u>	Yellow bass
<u>M. saxatilis</u>	Striped bass
Centrarchidae	
<u>Elassoma zonatum</u>	Banded pygmy sunfish
<u>Lepomis gulosus</u>	Warmouth
<u>L. humilis</u>	Orangespotted sunfish
<u>L. macrochirus</u>	Bluegill
<u>L. marginatus</u>	Dollar sunfish
<u>L. microlophus</u>	Redear sunfish
<u>L. punctatus</u>	Spotted sunfish
<u>Micropterus salmoides</u>	Largemouth bass
<u>Pomoxis annularis</u>	White crappie
<u>P. nigromaculatus</u>	Black crappie
Sciaenidae	
<u>Aplodinotus grunniens</u>	Freshwater drum

**ESTUARINE (23 species)**

Cyprinodontidae	
<u>Adinia xenica</u>	Diamond killifish
<u>Cyprinodon variegatus</u>	Sheepshead minnow
<u>Fundulus grandis</u>	Gulf killifish
<u>E. jenkinsi</u>	Saltmarsh killifish
<u>E. pulvereus</u>	Bayou killifish
<u>E. similis</u>	Longnose killifish
<u>Lucania parva</u>	Rainwater killifish
Atherinidae	
<u>Membras martinica</u>	Rough silverside
<u>Menidia beryllina</u>	Inland silverside
Syngnathidae	
<u>Syngnathus scovelli</u>	Gulf pipefish
Sparidae	
<u>Lagodon rhomboides</u>	Pinfish
Eleotridae	
<u>Dormitator maculatus</u>	Fat sleeper
<u>Eleotris pisonis</u>	Spinycheek sleeper
Gobiidae	
<u>Evorthodus lyricus</u>	Lyre goby
<u>Gobioides broussoneti</u>	Violet goby
<u>Gobionellus boleosoma</u>	Darter goby
<u>G. hastatus</u>	Sharptail goby
<u>G. shufeldti</u>	Freshwater goby
<u>Gobiosoma bosci</u>	Naked goby
<u>G. robustum</u>	Code goby
<u>Microgobius gulosus</u>	Clown goby

Table 19. Continued.

<u>M. thalassinus</u>	Green goby
Soleidae	
<u>Trinectes maculatus</u>	Hogchoker
<b>ESTUARINE-MARINE (26 species)</b>	
Elopidae	
<u>Elops saurus</u>	Ladyfish
<u>Megalops atlanticus</u>	Tarpon
Clupeidae	
<u>Brevoortia patronus</u>	Gulf menhaden
Engraulidae	
<u>Anchoa mitchilli</u>	Bay anchovy
Ariidae	
<u>Arius felis</u>	Hardhead catfish
<u>Bagre marinus</u>	Gafftopsail catfish
Gobiesocidae	
<u>Gobiesox strumosus</u>	Skilletfish
Belonidae	
<u>Strongylura marina</u>	Atlantic needlefish
Syngnathidae	
<u>Syngnathus floridae</u>	Dusky pipefish
<u>S. louisianae</u>	Chain pipefish
Carangidae	
<u>Oligoplites saurus</u>	Leatherjacket
Gerreidae	
<u>Eucinostomus argenteus</u>	Spotfin mojarra
Sparidae	
<u>Archosargus probatocephalus</u>	Sheepshead
Sciaenidae	
<u>Bairdiella chrysoura</u>	Silver perch
<u>Cynoscion arenarius</u>	Sand seatrout
<u>C. nebulosus</u>	Spotted seatrout
<u>Leiostomus xanthurus</u>	Spot
<u>Micropogonias undulatus</u>	Atlantic croaker
<u>Pogonias cromis</u>	Black drum
<u>Sciaenops ocellatus</u>	Red drum
<u>Stellifer lanceolatus</u>	Star drum
Ephippidae	
<u>Chaetodipterus faber</u>	Atlantic spadefish
Mugilidae	
<u>Mugil cephalus</u>	Striped mullet
Bothidae	
<u>Citharichthys spilopterus</u>	Bay whiff
<u>Paralichthys lethostigma</u>	Southern flounder
Soleidae	
<u>Achirus lineatus</u>	Lined sole



Table 19. Continued

## MARINE (106 species)

Carcharhinidae	
<u>Carcharhinus leucas</u>	Bull shark
<u>Rhizoprionodon terraenovae</u>	Atlantic Sharpnose shark
Pristidae	
<u>Pristis pectinata</u>	Smalltooth stingray
Dasyatidae	
<u>Dasyatis americana</u>	Southern stingray
<u>D. sabina</u>	Atlantic stingray
Albulidae	
<u>Albula vulpes</u>	Bonfish
Anguillidae	
<u>Anguilla rostrata</u>	American eel
Congridae	
<u>Hildebrandia flava</u>	Yellow conger
<u>Paraconger caudilimbatus</u>	Margintail conger
Ophichthidae	
<u>Gordichthys irretitus</u>	Horsehair eel
<u>Myrophis punctatus</u>	Speckled Worm eel
<u>Ophichthus gomesi</u>	Shrimp eel
<u>O. ocellatus</u>	Palespotted eel
Clupeidae	
<u>Harengula jaquana</u>	Scaled sardine
<u>Opisthonema oglinum</u>	Atlantic thread herring
Engraulidae	
<u>Anchoa cubana</u>	Cuban anchovy
<u>A. hepsetus</u>	Striped anchovy
<u>A. lyolepis</u>	Dusky anchovy
Synodontidae	
<u>Synodus foetens</u>	Inshore lizardfish
Batrachoididae	
<u>Opsanus beta</u>	Gulf toadfish
<u>O. pardus</u>	Leopard toadfish
<u>Porichthys plectrodon</u>	Atlantic midshipman
Antennariidae	
<u>Antennarius radiatus</u>	Singlespot frogfish
<u>Histrio histrio</u>	Sargassumfish
Ogcocephalidae	
<u>Ogcocephalus radiatus</u>	Polka-dot batfish
Gadidae	
<u>Urophycis cirrata</u>	Gulf hake
<u>U. floridana</u>	Southern hake
<u>U. regia</u>	Spotted hake
Bythitidae	
<u>Gunterichthys longipenis</u>	Gold brotula
Ophidiidae	
<u>Lepophidium graellsii</u>	Blackedge cusk-eel
<u>Ophidion welshi</u>	Crested cusk-eel
Exocoetidae	
<u>Cypselurus melanurus</u>	Atlantic flyingfish
<u>Hirundichthys affinis</u>	Fourwing flyingfish

Table 19. Continued.

<u>H. rondeleti</u>	Blackwing flyingfish
<u>Hyporhamphus unifasciatus</u>	Halfbeak
<u>Prognichthys gibbifrons</u>	Bluntnose flyingfish
Syngnathidae	
<u>Hippocampus erectus</u>	Lined seahorse
<u>H. zosterae</u>	Dwarf seahorse
Percichthyidae	
<u>Centropristis philadelphica</u>	Rock sea bass
Pomatomidae	
<u>Pomatomus saltatrix</u>	Bluefish
Rachycentridae	
<u>Rachycentron canadum</u>	Cobia
Echeneidae	
<u>Remora remora</u>	Remora
Carangidae	
<u>Alectis ciliaris</u>	African pompano
<u>Caranx crysos</u>	Blue runner
<u>C. hippos</u>	Crevalle jack
<u>C. latus</u>	Horse-eye jack
<u>Chloroscombrus chrysurus</u>	Atlantic bumper
<u>Hemicaranx amblyrhynchus</u>	Bluntnose jack
<u>Selene setipinnis</u>	Atlantic moonfish
<u>S. vomer</u>	Lookdown
<u>Seriola zonata</u>	Banded rudderfish
<u>Trachinotus carolinus</u>	Florida pompano
<u>T. falcatus</u>	Permit
<u>Trachurus lathami</u>	Rough scad
Coryphaenidae	
<u>Coryphaena hippurus</u>	Dolphin
Lutjanidae	
<u>Lutjanus apodus</u>	Schoolmaster
<u>L. griseus</u>	Gray snapper
<u>L. synagris</u>	Lane snapper
Lobotidae	
<u>Lobotes surinamensis</u>	Tripletail
Gerreidae	
<u>Diapterus plumieri</u>	Striped mojarra
<u>Eucinostomus gula</u>	Silver jenny
<u>E. melanopterus</u>	Flagfin mojarra
<u>Gerres cinereus</u>	Yellowfin mojarra
Haemulidae	
<u>Orthopristis chrysoptera</u>	Pigfish
Sciaenidae	
<u>Cynoscion nothus</u>	Silver seatrout
<u>Larimus fasciatus</u>	Banded drum
<u>Menticirrhus americanus</u>	Southern kingfish
<u>M. littoralis</u>	Gulf kingfish
<u>M. saxatilis</u>	Northern kingfish
Mugilidae	
<u>Mugil curema</u>	White mullet
Sphyraenidae	
<u>Sphyraena barracuda</u>	Great barracuda

Table 19. Concluded.

<u>S. borealis</u>	Northern sennet
<u>S. guachancho</u>	Guaguanche
Polynemidae	
<u>Polydactylus octonemus</u>	Atlantic threadfin
Uranoscopidae	
<u>Astroscopus y-graecum</u>	Southern stargazer
Blenniidae	
<u>Chasmodes bosquianus</u>	Striped blenny
<u>Hypleurochilus geminatus</u>	Crested blenny
<u>Hypsoblennius ionthas</u>	Freckled blenny
Eleotridae	
<u>Erotelis smaragdus</u>	Emerald sleeper
Gobiidae	
<u>Bathygobius soporator</u>	Frillfin goby
Microdesmidae	
<u>Microdesmus longipinnis</u>	Pink wormfish
Trichiuridae	
<u>Trichiurus lepturus</u>	Atlantic cutlassfish
Scombridae	
<u>Scomberomorus cavella</u>	King mackerel
<u>S. maculatus</u>	Spanish mackerel
Stromateidae	
<u>Peprilus alepidotus</u>	Harvestfish
<u>P. burti</u>	Gulf butterfish
Triglidae	
<u>Prionotus roseus</u>	Bluespotted searobin
<u>P. rubio</u>	Blackfin searobin
<u>P. salmonicolor</u>	Blackwing searobin
<u>P. scitulus</u>	Leopard searobin
<u>P. tribulus</u>	Bighead searobin
Bothidae	
<u>Ancylopsetta dilecta</u>	Three-eye flounder
<u>A. quadrocellata</u>	Ocellated flounder
<u>Citharichthys macrops</u>	Spotted whiff
<u>Etopus crossotus</u>	Fringed flounder
<u>Paralichthys squamilentus</u>	Broad flounder
Cynoglossidae	
<u>Symphurus civitatus</u>	Offshore tonguefish
<u>S. plagiusa</u>	Blackcheek tonguefish
Balistidae	
<u>Aluterus schoepfi</u>	Orange filefish
<u>A. scriptus</u>	Scrawled filefish
<u>Canthidermis sufflamen</u>	Ocean triggerfish
<u>Monacanthus hispidus</u>	Planehead filefish
Tetraodontidae	
<u>Lagocephalus laevigatus</u>	Smooth puffer
<u>Sphoeroides parvus</u>	Least puffer
Diodontidae	
<u>Chilomycterus schoepfi</u>	Striped burrfish
Molidae	
<u>Mola mola</u>	Ocean sunfish

species list for the Barataria Basin synthesized from the above studies, and an expansion from that presented in Deegan and Thompson (in press).

## 7.2 FINFISH

### 7.2.1 Composition

The heterogeneous fish assemblages living in the Barataria Basin result from the complex interplay of physical, chemical, and biological processes at work in the Mississippi River Deltaic Plain estuaries. These processes vary within the growth and decay stages of delta cycles (Chapter 1) and have been postulated to control diversity and productivity of the fishes in each estuary (Deegan and Thompson in press).

A total of 237 species of fishes in 74 families has been recorded from deltaic plain estuaries in Louisiana, with each estuary having a fauna resulting from local estuary characteristics (Table 20). A few groups dominate the fauna with most families being represented by only one to three species (Figure 42). Nine dominant families (12% of all families) contribute 91 species (38.3% of all species) to the overall fish assemblage of the deltaic plain estuaries: Sciaenidae (14 species), Centrarchidae (14 species), Carangidae (14 species), Gobiidae (12 species), Cyprinodontidae (9 species), Bothidae (8 species), Clupeidae (7 species), Ictaluridae (7 species), and Cyprinidae (6 species).

The fish community in the Barataria Basin is the most diverse for any estuary in Louisiana,

**Table 20.** Number of families, species, species/family, and ecological affinity species composition for fishes from Mississippi Deltaic Plain estuaries. FW = freshwater, ES = estuarine, EM = estuarine-marine, and MA = marine; top number = number of species, bottom ( ) = percent of total (Thompson and Deegan 1983; Deegan and Thompson, in press).

Estuary	Number families	Number species	Species/fam.	Habitat			
				FW	ES	EM	MA
Lake Pontchartrain	55	129	2.3	43 (33.3)	21 (16.3)	26 (20.2)	39 (30.2)
Lake Borgne	50	105	2.1	21 (20.0)	14 (13.3)	23 (21.9)	47 (44.8)
Mississippi Delta	40	94	2.4	33 (35.2)	19 (20.2)	21 (22.3)	21 (22.3)
Barataria Bay	65	186	2.9	31 (16.7)	23 (12.3)	26 (14.0)	106 (57.0)
Terrebonne/Timbalier	58	147	2.5	19 (12.9)	22 (15.0)	24 (16.3)	82 (55.8)
Fourleague Bay	43	86	2.0	11 (12.8)	18 (20.9)	24 (27.9)	33 (38.4)
Atchafalaya Bay	42	104	2.5	32 (30.8)	19 (18.3)	25 (24.0)	28 (26.9)

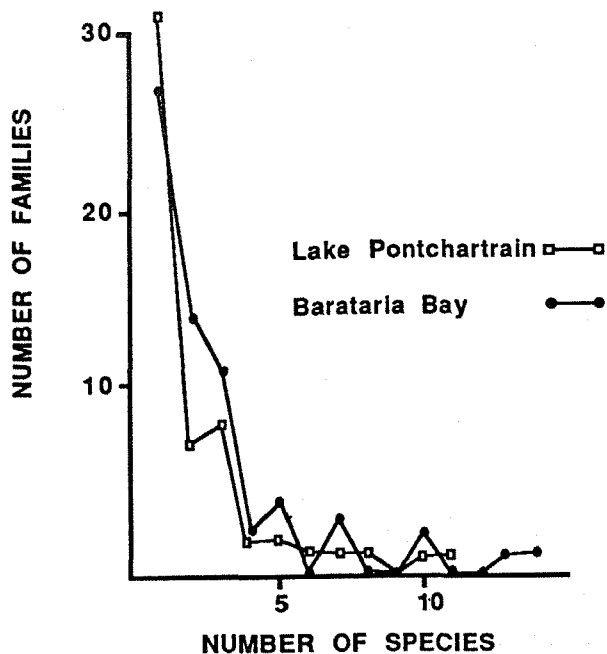


Figure 42. Species-family relationships for estuarine fishes for Barataria Bay and Lake Pontchartrain as representative northern Gulf of Mexico estuaries.

with 186 species from 65 families (Tables 20, 21). The high salinity regime in the basin, primarily the result of no riverine input, leads to environmental conditions in lower Barataria Bay nearly uniform with those of the inshore Gulf of Mexico. Thus, the fish community is dominated by marine species (57%). Using the Jaccard Index of Similarity (Long 1963, Boesch 1977) the fauna of Barataria Basin can be placed in context with other estuaries of the northcentral Gulf of Mexico (Table 22).

Nearly identical salinity regimes in adjacent Terrebonne-Timbalier Bay result in a fish fauna with similar characteristics to that in the Barataria Basin. Large areas of shallow, protected waters characterize these two systems as well as Calcasieu and Galveston Bays, two other systems with fish faunas similar to that found here. Conversely, areas like the Atchafalaya and Mississippi River Deltas have fish faunas dominated by freshwater species and so have low similarities even though they are nearby geographically. Thus, similar estuarine fish faunas seem to be more controlled by ecological similarity than geographical proximity.

Although marine species dominate the Barataria fish community by species, migratory estuarine-marine species (Thompson and Deegan 1983, Deegan and Thompson in press) are, by far, the most abundant and most frequently sampled species in the system. The demersal assemblage (a composite picture of trawl-caught fishes from Barrett et al. 1978 and Chambers 1980) contained the following 10 most abundant species: (1) bay anchovy, *Anchoa mitchilli*; (2) Atlantic croaker, *Micropogonias undulatus*; (3) Atlantic bumper, *Chloroscombrus chrysurus*; (4) Gulf menhaden, *Brevoortia patronus*; (5) spot, *Leiostomus xanthurus*; (6) hardhead catfish, *Arius felis*; (7) sand seatrout, *Cynoscion arenarius*; (8) Atlantic threadfin, *Polydactylus octonemus*; (9) striped anchovy, *Anchoa hepsetus*; and (10) gafftopsail catfish, *Bagre marinus*.

Seven of these species have estuarine-marine life histories (Figure 43) with the other three (Atlantic bumper, striped anchovy, and Atlantic threadfin) being marine species (Figure 43) with strong affinities for the lower reaches of higher salinity estuaries such as Barataria Bay.

Table 23 compares the relative abundance and biomass contributions of the fish assemblages between the upper (Chambers 1980) and lower (Wagner 1973) portions of the Barataria Basin. To a certain extent this is a contrasting of low- versus high-salinity regime fishes. Chambers' (1980) study had its lower limits at the upper boundary of Barataria Bay, with few salinity values above 8 ppt. Wagner's (1973) study ranged from the Barataria Bay-Gulf of Mexico interface into the upper reaches of Caminada Bay covering the lower, more saline, section of the basin. Mean salinity values from his study ranged from about 10 to 27 ppt. Chambers (1980) found a strong freshwater contribution in both abundance and biomass from the Ictalurid catfishes (blue and channel catfish) that was absent completely from the lower bay (Wagner 1973). Salinity-tolerant freshwater species such as the alligator gar (*Lepisosteus spatula*) can make up much of the nektonic biomass (Table 23) because of their large size.

The bay anchovy (*Anchoa mitchilli*) is the single most important member of the nektonic community from an ecological viewpoint, ranking first in abundance and second in biomass across the entire spectrum of the basin. Many other

**Table 21.** Fish families ranked by numbers of species in each family for the Mississippi Deltaic Plain.

RANK	Lake Pontchartrain	Lake Borgne	Mississippi Delta	Barataria Bay	Terrebonne/Timbalier	Fourleague Bay	Atchafalaya Bay
1	Centrarchidae 11	Sciaenidae 13	Sciaenidae 10	Sciaenidae 14	Sciaenidae 12	Sciaenidae 9	Sciaenidae 9
2	Sciaenidae 10	Clupeidae 6	Centrarchidae 8	Carangidae 13	Gobiidae 10	Carangidae 7	Ictaluridae 6
3	Cyprinodontidae 8	Centrarchidae 6	Cyprinodontidae 7	Centrarchidae 10	Carangidae 9	Gobiidae 6	Cyprinodontidae 6
4	Gobiidae 7	Carangidae 6	Gobiidae 7	Gobiidae 10	Cyprinodontidae 7	Clupeidae 5	Cyprinidae 5
5	Clupeidae 6	Gobiidae 5	Clupeidae 4	Clupeidae 7	Clupeidae 6	Cyprinodontidae 5	Gobiidae 5
6	Ictaluridae 5	Cyprinodontidae 4	Carangidae 4	Cyprinodontidae 7	Centrarchidae 5		Clupeidae 4
7	Carangidae 5			Bothidae 7	Gerreidae 5		Centrarchidae 4
8	Cyprinidae 4			Exocoetidae 5	Carcharhinidae 4		
9	Bothidae 4			Syngnathidae 5	Ophichthidae 4		
10				Gerreidae 5	Stromateidae 4		
11				Triglidae 5	Triglidae 4		
12				Ophichthidae 4	Bothidae 4		
13				Engraulidae 4			
14				Balistidae 4			

Jaccard's index	System	Similarity	Rank
0.63	Terrebonne	Very high	1
0.58	Calcasieu	High	2
0.57	Galveston	High	3
0.53	Lake Pontchartrain	Intermediate	4
0.48	Lake Borgne	Moderate	5
0.46	Atchafalaya/Vermilion	Moderate	6
0.45	Fourleague Bay	Moderate	7
0.41	Rockefeller Refuge	Low	8
0.41	Mississippi River Delta	Low	9

Species	Upper Bay <sup>b</sup>				Lower Bay <sup>c</sup>			
	Number	Rank	Weight (kg)	Rank	Number	Rank	Weight (kg)	Rank
<u>Anchoa mitchilli</u>	557,994	1	303.8	2	52,633	1	34.2	2
<u>Ictalurus punctatus</u>	27,871	2	404.5	1	--	--	--	--
<u>Micropogonias undulatus</u>	12,686	3	64.1	5	5,300	4	22.9	5
<u>Brevoortia patronus</u>	8,862	4	40.0	6	14,782	2	23.0	4
<u>Ictalurus furcatus</u>	3,498	5	80.3	4	--	--	--	--
<u>Leiostomus xanthurus</u>	245	18	trace		5,786	3	20.4	8
<u>Membras martinica</u>	1,563	8	trace		4,514	5	20.8	6
<u>Arius felis</u>	414	13	trace		2,169	6	52.5	1
<u>Bairdiella chrysoura</u>	10	--	trace		899	10	31.2	3
<u>Lepisosteus spatula</u>	25	--	255.8	3	3	--	20.6	7
<u>Menidia beryllina</u>	2,290	6	trace		836	11	trace	--
<u>Mugil cephalus</u>	277	16	trace		181	--	18.3	10

<sup>a</sup> All sampling gears combined.  
<sup>b</sup> Chambers 1980 (study done in 1978).  
<sup>c</sup> Wagner 1973 (study done in 1971-72).

migratory estuarine-marine fishes can have significant roles in the nekton community both in the upper and lower sections of the system as they move throughout the basin completing their life cycle (Figure 43).

### 7.2.2 Temporal Patterns

It has been pointed out in many estuarine studies that one of the most significant characteristics of the nektonic assemblages is seasonal change. Many of the most important species are transients to the estuary with

reasonably predictable seasonal patterns, but overall these communities never experience the dynamic winter decline characteristic of more northern estuaries. Tyler (1971) postulated that with stronger annual temperature fluctuations an estuarine community would have a higher proportion of periodic species and fewer resident members. Temperature seems to be the factor dictating the timing of many of the estuarine migratory patterns.

Sabins and Truesdale (1974) identified two seasonal assemblages of immature fishes

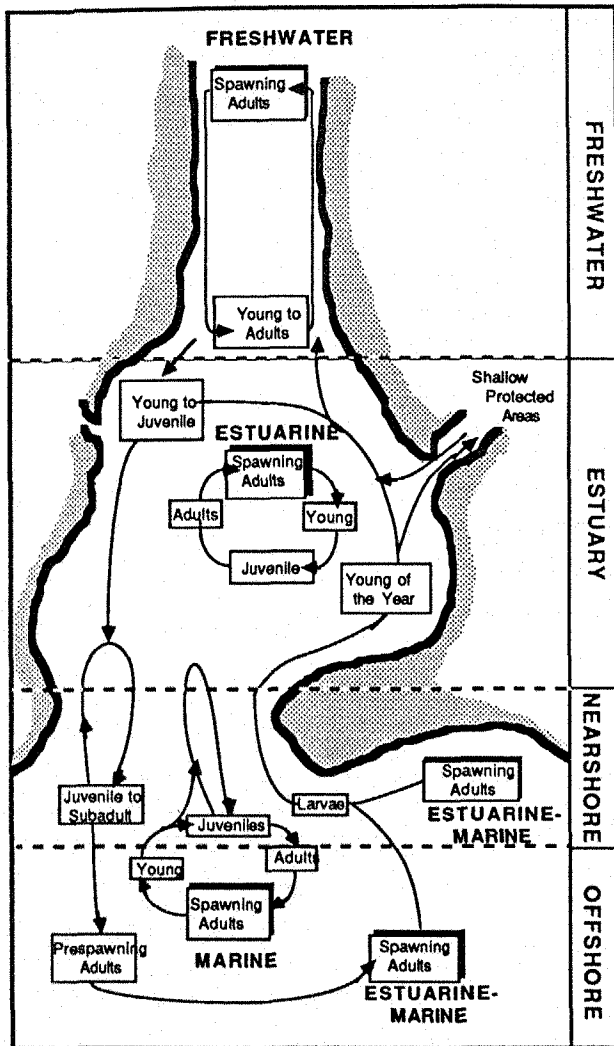


Figure 43. Diagrammatic representation of major fish life cycle patterns for northern Gulf of Mexico estuaries (modified from Deegan and Thompson, in press).

entering the Barataria system. A group called the "cold water assemblage" had their peak occurrence between November and April with mean water temperatures below 20 °C. This group consisted of such species as spot, Atlantic croaker, pinfish, southern flounder, spotted worm eel, gulf menhaden, and striped mullet. A second "warm water assemblage" peaked between May and October, with mean water temperature above 20 °C. Important fishes in this group include bay and striped anchovy, spotted seatrout, white

mullet, inland and rough silversides, silver perch, and Atlantic bumper. Several species such as red drum (*Sciaenops ocellatus*) spanned the time periods of both groups. Important nektonic invertebrates in the system would be both cold water (brown shrimp) and warm water (white shrimp and blue crabs) species. Seasonal patterns of juvenile and adult nekton identified by Chambers (1980) and Wagner (1973) agreed with those described by Sabins and Truesdale (1974).

Deegan and Thompson (in press) discussed the complex patterns of estuarine fish migrations in the Louisiana deltaic plain as arising from variations in environmental cues in each estuary. The characteristics of the Barataria system will often be different from those of many Atlantic and gulf coast estuaries because it lacks the strong influence of riverine input found in many of those estuaries. This system tends to warm faster and become more saline sooner in the spring, often leading to earlier migration times for many fishes and invertebrates compared to nearby systems like Lake Pontchartrain and Atchafalaya Bay, that are dominated by high spring river discharges (Deegan and Thompson, in press). This same characteristic will often delay fall migration patterns.

The seasonal changes in estuarine residence by many different fish species have been suggested as having evolved as a mechanism for partitioning the resources of the estuary (Deegan and Thompson, in press) that otherwise might become limiting with the simultaneous occupation by large numbers of abundant species. Not only are there strong seasonal "replacement" patterns in species using the basin's resources, but larger individuals of most nekton species migrate from the nursery areas first, leaving behind those individuals needing the advantages of the nurseries the most. This seasonal transition of groups of species using the middle and upper reaches of Barataria Bay, then being replaced by other groups, helps explain the diversity in the nektonic assemblages, particularly the fishes. It also provides some insight into why the dynamics of the entire community are so complex and difficult to explain in simple terms.

### 7.3 INVERTEBRATES

Most nektonic invertebrates in the Barataria Basin are decapod crustaceans or



cephalopod mollusks. The nektonic invertebrates of the Barataria Basin include a number of species which are of significant ecological importance to the trophic structure of the Basin. These include several species of penaeid shrimps and one species of portunid crabs. During certain stages of their seasonal life cycle, penaeid shrimps can be one of the most dominant species in terms of both numbers and biomass over much of the middle and lower basin. The most significant penaeid shrimps ecologically and commercially are the brown shrimp (Penaeus aztecus) and the white shrimp (Penaeus setiferus). Pink shrimp (Penaeus duorarum), seabobs (Xiphopenaeus kroyeri), and two species of Trachypenaeus can also be significant ecological components during certain seasons of the year; however, these do not comprise a large percentage of the commercial shrimp catch. The two major Penaeid shrimps exhibit a typical estuarine-marine life cycle (Figure 43). Postlarval brown shrimp begin to appear in Barataria Bay passes in late winter or early spring and migrate towards low-salinity protected areas during their early postplanktonic life stages. Allen (1979) found that brown shrimp move into the basin making intensive use of the 0-14 ppt salinity regime. In these areas, they feed on rich detrital bottoms, and at temperatures above 20 °C, can grow up to three millimeters per day. By late May or early June, these shrimps can reach subadult size and begin to migrate from the shallower marsh pond and bay areas into larger bays, eventually reaching the Gulf of Mexico. These migrations continue into early summer when vast numbers of these shrimps use outflowing currents through main tidal passes emigrating from the basin to complete their life cycle on the Continental Shelf in the Gulf of Mexico where spawning takes place (Farfante 1969).

The white shrimp follows a life cycle similar to the one described for brown shrimp, but later in the year, so that postlarvae enter tidal passes in late spring and early summer and subadult size is reached by late summer, generally in late August. This resource partitioning allows the two species to use the rich nursery grounds of the basin, while avoiding substantial competition with each other. White shrimp migrations to the gulf occur during the early fall and the timing of these migration pulses is strongly influenced by the passage of cold fronts. White shrimp can be found within the basin in abundance even in mid to late fall with continual mild weather. During typical weather

years, some white shrimp will even overwinter within the basin and these adults will migrate to the Gulf of Mexico in the early spring to complete their life cycles (Farfante 1969).

Pink shrimp also follow this similar life cycle except that the greatest abundance of adults occurs during winter, indicating that spawning and migrating to the basin is completed after the main pulse of white shrimp emigration. Pink shrimp are therefore typically found in the bay during late winter and early spring. Pink shrimp constitute a minor component of the nekton in Barataria Bay compared with brown and white shrimps. This is consistent with the pink shrimps' preference for higher salinity waters and sandy seabottoms.

Several species of portunid crabs are ecologically important during certain seasons within Barataria Basin. Primary among these is the well-known blue crab (Callinectes sapidus) of significant commercial and sport fishing importance. Much has been written on the life history of this crab (Darnell 1959). It generally follows the estuarine-marine life cycle that was described earlier in this chapter for penaeid shrimps (Figure 43). Large numbers of ovigerous females ("berry crabs") can be found in lower portions of the basin during late summer prior to their emigration to offshore waters to spawn. The lengthy distances of these migrations are covered by swimming at or near the surface in the Gulf of Mexico. A related species, C. similis, the lesser blue crab, is also abundant in the Barataria Basin, particularly in higher salinity areas. In fact, C. similis is more abundant than C. sapidus over wide areas of the lower basin, a reflection of the high average salinity regime. This species does not reach commercial size and does not enter the crab fishery in the basin or offshore. It also does not exhibit the differences in migratory pattern of the blue crab whereby adult females emigrate offshore for the hatching of eggs and mature males generally stay in fresher water areas for the remainder of their life cycle. Both sexes of C. similis emigrate offshore and complete their adult life cycles on the Continental Shelf of the Gulf of Mexico.

Among other portunid crabs, only Portunus gibbesii uses the lower bay in relatively large numbers to play a role in the nekton community. The adults of this species are typically found in the Gulf of Mexico. There are a number of

other species of decapod crustaceans in the basin, but full discussion of their life histories is outside of the scope of this chapter.

The brief squid (*Lolliguncula brevis*) is the only nektonic mollusk that occurs in any number within the Barataria Basin. *Lolliguncula brevis* exhibits a seasonality that reaches its peak in late summer and early fall. This is correlated with higher water temperature and salinities, with variation in abundance related to estuarine zooplankton populations, a prime food of the least squid (Roper et al. 1984). This squid is a true estuarine species (Roper et al. 1984) and there is evidence of egg disposition and early developmental stages of this squid within the basin. This is contradictory to Haedrich (1983) who stated that squids do not occur in estuarine areas. A second species of squid, *Loligo pealei*, occurs in the shallow Gulf of Mexico, but has not been recorded within the inshore waters of Barataria Basin.

## 7.4 COMMUNITY DYNAMICS

### 7.4.1 Physical Factors

The physical, geographic, and geometric dimensions of the Barataria Basin (Chapters 1 and 2) strongly influence the distribution and character of the nektonic fauna within the basin. The flat, marshy, low-lying nature of the basin, coupled with the fact that there is no direct river inflow, leads to a salinity regime that is variable both over an annual cycle and over much shorter periods due to certain meteorological factors. Thus, the classical estuarine salinity and faunal gradient often exhibited by well-studied east coast estuaries within the United States is not applicable to the study of the Barataria Basin and, for that matter, most other estuarine basins within Louisiana. High nekton productivity in the Barataria Basin may result from the reduced stress of maintaining physical position in the estuary against strong tidal currents and freshwater riverine flow (Dando 1984) since both of these factors are minimal in the system. There is normally a salinity gradient from north to south, i.e., increasing salinities in the southern part of the basin near the Gulf of Mexico. However, the magnitude of this gradient is variable depending on the seasons of the year and localized meteorological conditions. Therefore, nekton distributions are generally not as predictable in the basin as they may be in east coast estuaries.

Since the completion of the Mississippi River levee system in the late 1930's, the direct impact of this river on the basin has virtually been eliminated (Chapter 1). The Mississippi River does, however, continue to influence the basin through a more indirect method. During the spring, when discharge rates are high in the Mississippi River, the Gulf of Mexico offshore from the Barataria Basin can frequently exhibit very low surface salinities compared to periods later in the year. This is caused by the lower density of freshwater which tends to flow out across the surface of the gulf. For instance, the junior author has taken top and mid-water samples in 45 ft of water offshore Barataria Bay that show differences of as much as 14 ppt (as NaCl). Depending on climatic conditions and surface winds, this freshwater plume can be swept into the basin during inflowing tidal periods. We have seen occasions where salinities at the beach of the Gulf of Mexico are considerably less than salinities within the barrier islands of the basin. This influx of Mississippi River water via the Gulf of Mexico can be clearly noted by the presence of large quantities of water hyacinths, duckweed, and other freshwater aquatic flora washed from the freshwater marshes surrounding the Mississippi Delta into the Gulf of Mexico. For short periods during the spring, this can result in some reversal of salinity or of homogenization of the salinity regime throughout parts of the basin (Broussard 1982). This permits penetration of freshwater nekton from the upper basin to the lower, normally more saline, reaches of the basin during these periods. During the record high Mississippi River flows in the spring of 1973, Forman collected the freshwater river shrimp, *Macrobrachium ohione*, at Grand Isle adjacent to the Gulf of Mexico, well beyond its normal distribution.

The lack of direct riverine input into the basin has influenced the character of the freshwater component (Table 20) of the nektonic fauna. This fauna is adapted to the extensive lentic and semilentic swamp and freshwater marsh habitats that dominate the upper reaches of the basin. Although these freshwater areas are subject to some flow caused by tidal influences, the fish and nektonic invertebrate fauna of these areas are typically backwater pond and lake forms, with few stream or large river species.

## 7.4.2 Environmental Factors

a. Abiotic factors. The passage of cold-weather fronts, with associated strong northerly winds, strongly influences the distribution of nekton within the basin. These fronts can "override" the normal tidal cycle in south Louisiana and can result in a large displacement of estuarine waters from the basin to the Gulf of Mexico, often containing large numbers of juvenile fishes and macroinvertebrates (Sabins and Truesdale 1974). If this is coupled with heavy rainfall, salinity regimes can be significantly altered and even become quite disjunct in distribution, often with pockets of low salinity water scattered in the lower bay. Strong prevailing southerly winds can have the opposite influence in that tides will be overridden by a massive influx of water from the Gulf of Mexico. This results in excursions of high salinity waters, particularly in late summer into the lower basin. Many marine species of fish, such as adult crevalle jack (Caranx hippos), Spanish mackerel (Scomberomorus maculatus), bluefish (Pomatomus saltatrix), and others enter the lower bay during these periods.

Strong southerly winds of several days duration will override normal tides, causing extremely high water levels that flood-out over the marsh. The feeding habits of typical estuarine predators, such as speckled trout (Cynoscion nebulosus) and redfish (Sciaenops ocellatus), are adversely affected during these periods, resulting in "poor fishing." These species, and others, tend to feed during moving tides and these periods retard that activity. Many shallow-water shoreline species such as killifishes, silversides, and the young of many estuarine-marine species move onto the flooded marsh at this time to feed.

Rainfall, the only major source of fresh-water within the basin, can also have a significant impact on the distribution of nekton within the basin. The normal seasonal cycle of higher rainfall during the late fall, early winter, and early spring can reduce salinities within the basin and allow for transitory passage of some fresh water species, such as the two Dorosoma species, into the normally higher salinity areas of the basin. Conversely, during the low rainfall period of late summer to early fall, higher salinities can be noted throughout the basin; it is during this time that many marine species enter lower portions of the bay, since conditions are similar to those found in

the adjacent Gulf of Mexico. Rainfall is sufficient to provide low-salinity habitat for many species of fish and macroinvertebrates, in contrast to many lower coast Texas estuaries where limited riverine input and low rainfall produce strong hypersaline conditions, particularly in the warmer seasons.

The winds associated with typical winter frontal passages can physically reduce the areal extent of environment available to certain nektonic species (i.e., marsh ponds, shallow embayments, etc.) and can therefore have a significant temporary impact on the distribution of nekton. In essence, water is simply blown out of the shallow environments and much of the fauna is forced to move to deeper, generally more open bay areas. These frontal passages are often accompanied by low air temperatures (near 0 °C). Most species are able to survive these passages without lethal effects, moving into deeper, warmer bay waters as the marsh is blown dry. Excessively cold frontal passages during the winter of 1983-84 resulted in significant mortalities of a number of marine species in the Barataria Basin and elsewhere in southeast Louisiana.

b. Biotic factors. Oxygen depletion in the shallow Gulf of Mexico has a potentially strong negative influence on the dynamics of the nekton in the Barataria Basin. Forman (unpublished) has observed this phenomenon for several years, but only recently has the occurrence been documented in the Gulf of Mexico (See review by Rabalais et al. 1985). The presence of an oxygen-depleted bottom layer in the Gulf of Mexico directly offshore from the Barataria Basin could have a significant impact upon the nektonic fauna that uses the basin for either a nursery ground or a transitory feeding area. These species (such as white shrimp) must attempt to pass through this zone of oxygen depleted waters (Boesch 1983) on their routes from the Gulf of Mexico to the basin or vice versa. Species such as Atlantic croaker, spot, gulf menhaden, and others, having completed their estuarine stay in the system and migrating into the Gulf of Mexico, would encounter this obstruction.

"Red tides," which have been classically described from the gulf coastal waters of Florida, have not been clearly documented for the Barataria Basin. There have been some implications of a phytoplanktonic "red tide" organism as the cause of some fish kills within and near the

Barataria Basin, but additional research is needed to document this phenomenon.

## 7.5 NEKTONIC RESOURCES AND HUMAN INFLUENCE

### 7.5.1 Sport, Recreational, and Commercial Fisheries

The Barataria Basin supports an important sport and recreational fishery, centered on species that depend upon the basin during phases of their life cycle. Of primary importance are spotted seatrout, redfish, croaker, sand seatrout, and flounder among the fishes, and penaeid shrimps and blue crabs among the invertebrates.

The Barataria Basin also supports a strong commercial fishing industry particularly for penaeid shrimps, blue crabs, spotted seatrout, redfish, flounder, menhaden, croakers, and a number of other species which use the basin during portions of their life cycle. Most nekton targeted by recreational and commercial interests are estuarine-marine species (Figure 43) that seasonally use the basin for various life history needs as they complete their migratory life cycle.

### 7.5.2 Human Influence

a. Water quality. The upper Barataria Basin experiences some degree of stress caused by municipal discharges (sewage) from the metropolitan New Orleans area and discharges of urban rainwater runoff. These discharges have resulted in lowered water quality in those swamp areas nearest the city, primarily from eutrophication and depressed oxygen levels caused by organic matter and nutrient input (see Chapter 3). Quantifying the effects of these discharges on the distribution and character of the nektonic fauna of the upper basin is recommended for future research.

There are a great number of recreational fishing camps in the basin that contribute to sewage pollution. This, coupled with sewage in the Mississippi River water that enters the basin through navigation locks, has resulted in closures of certain areas to oyster harvesting because of fecal coliform bacteria. The problem is currently under study by the Louisiana Department of Health and Human Resources. The effects of

these sanitary wastes on nekton populations has not been documented for the basin.

b. Industrialization. There is little true industrial activity within the tidally-affected portions of the basin. There is, however, significant industrialization along the Mississippi River which forms the upper, eastern boundary of the basin. This industry is isolated from the basin for the most part by flood protection levees, and discharges are typically directed to the Mississippi River.

There is a significant mineral exploration and production industry present within the basin proper. This consists primarily of oil and gas extraction. Perry (1979) and Waller (1979) concluded that oil and gas activities had no significant effect on fish and invertebrate assemblages in adjacent Timbalier Bay. Sulphur production by the Frasch mining process has occurred in the basin, but there are currently no active mines in operation within the basin.

c. Erosion and wetland loss. This is an important and volatile issue in the basin as well as all of southeastern Louisiana (see Chapters 1, 2, and 11). A significant contribution to the problem was the leveeing of the Mississippi River, which prevented the annual overflowing of sediment-rich waters into the shallow basin areas. This situation has been exacerbated by the dredging of navigation and mineral production access canals within the basin. This conversion from marsh or broken marsh to open water habitat has affected the composition and magnitude of various nekton, particularly the migratory estuarine-marine species seeking shallow, protected areas as critical nursery grounds during the first few months of their life cycle. Studies are currently underway to determine the feasibility of "re-introduction" of Mississippi River water into the basin in an attempt to build new marshland and, in addition, restore previous salinity regimes (i.e., retard saltwater intrusion). If these programs are implemented, there will be a significant alteration in the distributional patterns of many nektonic species, since, as discussed earlier, salinity regime seems to be the most important environmental factor determining the species composition of the fish community. The magnitude of the community readjustment will depend on the scope and size of the proposed water introductions, but the possibility exists that a riverine component of the

fish community could become established in the upper basin.

d. By-catch. Much of the shrimp fishery in Barataria Bay is by trawling, although mid-water stationary "butterfly nets" are heavily used seasonally to harvest emigrating brown and white shrimp in tidal passes. The "by-catch" from both trawling and butterfly nets is substantial, with studies showing a 75% reduction in demersal biomass occurring within the basin shortly after the opening of shrimp-trawling season. For the most part, fishes taken with the shrimp harvest are not used and discarded overboard. Most organisms, except the blue crabs, are killed when caught by trawling. This is a significant factor affecting the character and magnitude of nekton within the lower basin during the late spring to early fall when shrimp-trawling seasons are open. The trawl by-

catch is dominated by young of the migratory estuarine-marine fishes using the bay area as a nursery. This commonly includes Atlantic croaker, spot, sand seatrout, gulf menhaden, hardhead and gafftopsail catfish, and bay anchovy. Many common marine fishes such as Atlantic bumper, Atlantic threadfin, striped anchovy, gulf butterfish, star drum, and others are often taken in substantial numbers in the lower bay. In addition, many rarer species are taken in smaller numbers. The wing net by-catch contains many of the same species taken by trawling but more pelagic species are caught. Thompson (unpublished data) found that spotted and sand seatrout, gulf menhaden, bay anchovy, gizzard and threadfin shad, least puffer, Atlantic croaker, spot Atlantic bumper, and hardhead catfish made up much of the wing net by-catch in the fall harvest of white shrimp in Lake Pontchartrain tidal passes.

## CHAPTER 8

### WILDLIFE

by

R. K. Abernethy

#### 8.1 INTRODUCTION

The swamps, bays, bayous, and marshes of Barataria Basin are inhabited by more than 400 species of birds, 30 species of mammals, and 70 species of reptiles and amphibians (Lowery 1974a; Lowery 1974b; Dr. Douglas B. Rossman, Curator, LSU Natural Science Museum; pers. comm.). This wildlife population is diverse, with members ranging from the huge flocks of waterfowl that visit the marshes in the fall to the small, inconspicuous harvest mouse (Reithrodontomys fulvescens) of the fresh marshes. Flocks of white pelicans (Pelecanus erythrorhynchos) numbering in the hundreds can often be seen over Leeville and Grand Isle, while snowy egrets (Egretta thula) are visible in almost every bayou along Highway 1. The fact that the Barataria Basin supports such an incredible amount of wildlife is even more amazing when one considers that the basin borders New Orleans, and many people seek relaxation and enjoyment through this bountiful wildlife resource. Trapping and hunting annually draw over 400,000 people to Louisiana's marshes and woodlands in search of white-tailed deer (Odocoileus virginianus), waterfowl, muskrat (Ondatra zibethicus), and nutria (Myocastor coypus) (LDWF 1983). Because of the abundance of game and the easy accessibility, a large portion of these sportsmen choose the Barataria Basin. Bird watchers and wildlife photographers are also beginning to explore and appreciate the beauty, solitude, and peacefulness of the marshes and swamps.

Wildlife, then, is very important to the people of Louisiana as a source of recreation, income, aesthetic beauty, and pride. It is also

ecologically important in the natural cycles of the marsh. Top carnivores such as the bald eagle (Haliaeetus leucocephalus) and brown pelican (Pelecanus occidentalis) serve man as valuable indicators of environmental quality. The dramatic decrease of these two species in the Barataria Basin and elsewhere during the late 1950's led to the realization of the dangers of pesticide poisoning and its harmful effects on avian reproduction (Lowery 1974a). Happily, though, with the ban of DDT and the reintroduction of brown pelicans to Queen Bess Island in 1968, these fine aerialists can again be seen diving offshore at Grand Isle. The bald eagle is still in trouble, but four active eagle eyries remain within the basin (Dugoni 1980).

In the following discussion of the wildlife of Barataria Basin birds will be broken into six groups (Peterson 1980). The general habits and habitat requirements of the groups can thus be more easily discussed without mentioning all of the individual species. Mammals will be discussed in four groups, and the reptiles and amphibians will be lumped into two groups, land and marine (Table 24).

#### 8.2 BIRDS

##### 8.2.1 Distribution

Some 411 species of birds have been reported in Louisiana. Of these, 98 are permanent residents that are known to breed here and 120 are winter visitors (Lowery 1974a). Most of these 218 birds are seasonally abundant in specific habitats throughout Barataria Basin. Certain highly visible species occur in huge

Table 24. Groupings of animals of Barataria Basin.

Birds

- a. Swimmers: loons, grebes, cormorants, anhingas, waterfowl, coots, gallinules
- b. Seabirds: pelicans, gulls, terns, skimmers
- c. Long-legged waders: herons, bitterns, egrets, ibis, storks
- d. Shore birds: rails, avocets, plovers, sandpipers, snipe
- e. Birds of Prey: hawks, eagles, owls, vultures, falcons, kites
- f. Passerine birds: flycatchers, larks, swallows, crows, titmice, nuthatches, creepers, wrens, gnatcatchers, thrashers, thrushes, shrikes, waxwings, vireos, warblers, blackbirds, tanagers, finches, sparrows

Mammals

- a. Bats
- b. Small mammals: mice, rats, shrews
- c. Furbearers: nutria, muskrat, mink, otter, opossum, bobcat, fox, raccoon
- d. Game animals: deer, squirrels, rabbits

Reptiles and amphibians

- a. Land: snakes, turtles, lizards, frogs, salamanders
- b. Marine: sea turtles

concentrations during certain times of the year. Flocks of white pelicans in excess of 500 individuals can often be seen feeding in the salt marsh alone or with equally large flocks of common and snowy egrets during the winter. The long legged waders also congregate in nesting colonies in specific locations across the basin year after year. These colonies often hold in excess of 1,000 adult birds (Figure 44). Waterfowl also congregate in flocks, often numbering in the thousands. Birds are by far the most visible wildlife in Barataria Basin. A discussion of a few of the most common birds and bird groups follows.

The swimmers inhabit every habitat within the basin. Loons, grebes, and cormorants are for the most part migratory and spend winters fishing in the saline and brackish marshes and bays of south Louisiana. Anhingas (*Anhinga anhinga*) and gallinules (*Porphyrula martinica*, *Gallinula chloropus*), common summer nesters throughout the fresh marsh and swamp habitats, depart for southern climates with the onset of cool weather. The mottled duck (*Anas fulvigula*), common in fresh and intermediate marshes, and the wood duck (*Aix sponsa*) of wooded streams and swamps are our only nesting waterfowl. The great bulk of waterfowl begin arriving in October and populations continue to increase until mid-winter.

The puddle ducks, mallard (*Anas platyrhynchos*), blue-winged teal (*Anas discors*), and green-winged teal (*Anas crecca*) are most



Figure 44. Egret, ibis, and heron rookery near Lake Boeuf (photo by R. Abernethy).



common in the small, shallow, fresh and intermediate marsh ponds dominated by Panicum hemitomon or Sagittaria lancifolia surrounding Lake Salvador, Lake Boeuf, Lac des Allemands, and north of Little Lake. Gadwall (Anas strepera) are common in flocks of several hundred during the fall and early winter in the ponds and impoundments of the brackish marsh. During late winter and early spring the gadwall and pintail move down into the saline marsh and feed primarily on filamentous algae (Paulus 1982; Abernethy 1986). Lesser scaup (Aythya affinis) and red-breasted merganser (Mergus serrator) are both common in the open waters of Barataria Bay and Caminada Bay.

Seabirds, as the name indicates, are most common along the barrier islands and inland bays of Barataria Bay. Keller et al. (1984) surveyed nesting colonies along the barrier islands. She found nearly 50 colonies of black skimmers (Rynchops niger) and least terns (Sterna albigrons). Twelve other colonies of Forster's terns were also located. The Forster's terns preferred nesting on driftage or "wrack" piled on the marsh while the skimmers and least terns preferred bare ground on the beach. One colony of brown pelicans was found nesting on a black mangrove (Avicennia germinans) island in Barataria Bay. This colony, which contained 48 adults when surveyed by Portnoy (1977), has since increased to over 1000 adults (Larry McNease, LDWF Biologist, Rockefeller Refuge; pers comm).

The long-legged wading birds are conspicuous and are found in every habitat from the salt marsh to sugar cane field canals. Their nesting requirements, however, are very specific. Keller et al. (1984) located 28 nesting colonies in Barataria Basin. The largest at Lagan, Louisiana, contained 5,000 adults of six species. Great egrets (Casmerodius albus; Figure 45), great blue herons (Ardea herodias), and anhingas nest in tall mature cypress (Taxodium distichum) and water tupelo (Nyssa aquatica) trees, while the smaller herons, egrets, and ibis prefer the smaller bushes and shrubby trees around ponds and along pipelines in the swamp. The most common nesting habitat in the salt marsh is black mangrove thickets on islands in Barataria Bay (Portnoy 1977).

The shore birds are primarily winter visitors of sand beaches and tidal mud flats where they can often be seen in incredible numbers during



Figure 45. Great egret, or American white egret, in fresh marsh (photo by W. Conner).

migration. The most common nesters are the king rail (Rallus elegans), clapper rail (Rallus longirostris), black-necked stilt (Himantopus mexicanus), kildeer (Charadrius vociferus) and willet (Catoptrophorus semipalmatus) (Lowery 1974a).

Birds of prey are common throughout the year in all habitats. They reach their highest populations during migration. The most common winter resident of the marshes is the marsh hawk (Circus cyaneus), while common year-round resident nesters of the swamps and woodlands are the red-shouldered hawk (Buteo lineatus), barn owl (Tyto alba), great horned owl (Bubo virginianus), barred owl (Strix varia), black vulture (Coragyps atratus), and turkey vulture (Cathartes aura). Passerine birds are found in every habitat with the greatest populations and species diversity found along ecotones in the swamp and bottomland hardwood forests.

### 8.2.2 Seasonal Abundance

One of the most interesting aspects of ornithology is the study of migrations. Louisiana is at the bottom of the Mississippi Flyway, and in the



fall birds from central and northern North America converge on Louisiana. Shore birds begin arriving in mid-July and the peak in numbers is reached in September. The waterfowl migration begins in mid-August with the arrival of blue-winged teal. They are joined in October by gadwall, widgeon, pintail, and shoveler. Populations peak in December with the arrival of mallards and divers. The State of Louisiana annually winters between 5 and 10 million waterfowl with southeastern Louisiana (of which Barataria Basin is a part) attracting about 30% of the total (LDWF 1984; Byrd and Smith 1985). Birds of prey and passerines also descend on the state. Some stay all winter, but many stay only a few days before departing for points further south.

As impressive as the fall migration can be, the spring return of migrants can be even more so. The spring migration starts in late February or early March and peaks in late April and early May. During this peak, as many as 50,000 birds/night/mi of shoreline enter Louisiana (Gauthreaux 1971). These birds, primarily passerines, cross the gulf and move inland almost every night during this period. If the weather is clear, they do not land until 30-50 mi inland in the vast swamps and forests of inland Louisiana. But, if the migrants are met with storms and strong northern cold fronts over the gulf, they descend in incredible numbers along the beaches and cheniers of southern

Louisiana (Lowery 1974a). At these times, oak trees at Grand Isle may contain hundreds of warblers, flycatchers, vireos, and other passerines (Lowery 1945). These birds feed intensively throughout the day and usually head north again shortly after sunset (Hebrard 1971).

Most wading birds do not migrate from Louisiana. Their populations climb throughout the summer to a peak at the end of the nesting season in early July. This increase in populations is also true of most other less conspicuous resident nesters such as passerines and birds of prey.

### 8.2.3 Food Habits

Many of the swimmers, seabirds, and long-legged wading birds feed on fish though their fishing techniques are vastly different. Loons, grebes, cormorants, and anhingas pursue their prey underwater, while brown pelicans, terns, and gulls dive from varying heights to catch fish. Skimmers, true to their name, skim along with only their lower mandible in the water, catching any small fish they touch. The long-legged waders prefer to stalk their prey while wading quietly through the shallows. The waders also vary their diet of fish with crayfish, grasshoppers, cut-worms, lizards, frogs, and snakes (Baynard 1912; Table 25).

**Table 25.** Major food items of 354 wading birds. Samples are based on 1 adult or 50 young (adapted from Baynard 1912).

Species	Food item						
	Grasshoppers	Crayfish	Fish	Cutworms	Frogs	Snakes	Insects
<b>Adult</b>							
Glossy ibis	12	19	0	14	0	1	1
Little blue heron	51	3	0	3	2	0	0
Green heron	16	6	0	2	trace	0	0
Tricolored heron	200	0	0	0	0	0	0
<b>Young</b>							
Little blue heron	1900	142	0	149	37	0	0
Egrets	0	176	61	0	297	49	0
White ibis	308	602	0	352	0	42	0
Tricolored heron	2876	67	0	17	8	0	0
Snowy egrets	762	29	120	91	0	7	0
Anhinga	0	0	all	0	0	0	0
Night heron	0	60	641	0	0	0	79
<b>TOTAL</b>	<b>6,125</b>	<b>1,104</b>	<b>822</b>	<b>628</b>	<b>344</b>	<b>99</b>	<b>80</b>

Waterfowl feed on a great variety of plant and animal species. Feeding habits vary from species to species and depend a great deal on food availability. Glasgow and Bardwell (1962) found pintails (*Anas acuta*) ate 98.6% vegetable matter and 1.4% animal matter. Primary plant species used were, in order of decreasing abundance, fall panicum (*Panicum dichotomiflorum*), brownseed paspalum (*Paspalum plicatulum*), Walter's millet (*Echinochloa walteri*), American cupscale (*Sacciolepus striata*), and barnyard millet (*Echinochloa crusgalli*). Chamberlain (1959) examined 1,251 gizzards of 17 species of waterfowl and also found high use of vegetable matter by most species, primarily seeds of *Cladium*, *Scirpus*, and *Eleocharis*. Notable exceptions were the diving ducks, which consumed large quantities of insects, mollusks, fishes, and crustaceans (Table 26).

The shore birds seen along barrier beaches and mud flats feed primarily on very small insects, crustaceans, mollusks, and worms (Peterson 1980). Rails feed in the marshes on crabs, snails, and insects (Bateman 1965).

The birds of prey are carnivores and with few exceptions eat rodents, snakes, and birds (Lowery 1974a). Three exceptions are the uncommon ospreys (*Pandion haliaetus*) and bald

eagles, which eat fish, and vultures, which eat carrion.

The passerines have widely varied food habits. Swallows and swifts prefer to take their insects on the wing; sparrows on the other hand scratch out insects and weed seeds along spoil banks in the swamp (Lowery 1974a; Peterson 1980).

### 8.3 MAMMALS

#### 8.3.1 Distribution

Eight species of bats, eleven species of small mammals, seven furbearers, five game animals, and the armadillo are found in the swamps, marshes, wet pastures, and hardwood ridges of Barataria Basin (Burt and Grossenheider 1964; Lowery 1974b; Table 27). Bats are common, though not often seen, throughout the basin. Being nocturnal, they roost during the day in hollow trees, in clumps of Spanish moss (*Tillandsia usneoides*), and in the attics of old houses, sheds, and camps. They are most common in swamps and along natural levees and ridges where roost sites are plentiful. Trapper's shacks and hunt camps provide additional roosting sites far out into the marsh.

Waterfowl	Percent						
	Plant material			Animal material			
	Seeds	Vegetation	Tubers	Insects	Mollusks	Fishes	Crustaceans
Mallard	99	2	1	16	3	1	1
Pintail	100	4	--	12	3	--	1
Wigeon	93	65	--	11	1	1	--
Green-winged teal	100	--	--	18	9	--	--
Gadwall	95	48	--	7	3	1	--
Mottled duck	100	3	--	22	10	4	1
Shoveler	100	6	--	43	52	6	6
Blue goose	39	100	56	--	--	--	--
Blue-winged teal	100	--	--	20	20	--	--
Scaup	100	--	--	11	56	--	--
Canada goose	63	75	25	--	--	--	--
Canvasback	100	17	--	33	83	33	--
Redhead	100	20	--	40	60	20	--
Hooded merganser	--	25	--	--	--	--	75
Buffelhead	100	--	--	50	50	--	--
Black duck	100	--	--	--	--	--	--
Red-breasted merganser	--	--	--	--	--	100	--

**Table 27.** Checklist of the mammals of Barataria Basin. A = abundant, C = common, FC = fairly common, NC = not common.

Scientific name	Common name	Occurrence
<u>Myotis austroriparius</u>	Southeastern myotis	NC
<u>Pipistrellus subflavus</u>	Eastern pipistrelle	C
<u>Lasiurus borealis</u>	Red bat	C
<u>Lasiurus seminolus</u>	Seminole bat	C
<u>Lasiurus intermedius</u>	Northern yellow bat	FC
<u>Nycticeius humeralis</u>	Evening bat	C
<u>Plecotus rafinesquii</u>	Rafinesque's big-eared bat	C
<u>Tadarida brasiliensis</u>	Brazilian free-tailed bat	C
<u>Cryptotis parva</u>	Least shrew	C
<u>Glaucomys volans</u>	Southern flying squirrel	C
<u>Oryzomys palustris</u>	Marsh rice rat	A
<u>Reithrodontomys fulvescens</u>	Fulvous harvest mouse	A
<u>Peromyscus leucopus</u>	White-footed mouse	C
<u>Peromyscus gossypinus</u>	Cotton mouse	C
<u>Sigmodon hispidus</u>	Hispid cotton mouse	A
<u>Neotoma florida</u>	Eastern wood rat	FC
<u>Rattus rattus</u>	Roof rat	C
<u>Rattus norvegicus</u>	Norway rat	C
<u>Mus musculus</u>	House mouse	C
<u>Dasypus novemcinctus</u>	Nine-banded armadillo	C
<u>Didelphus virginiana</u>	Opossum	C
<u>Ondatra zibethicus</u>	Muskrat	A
<u>Myocaster coypus</u>	Nutria	A
<u>Procyon lotor</u>	Raccoon	C
<u>Mustela vison</u>	Mink	NC
<u>Lutra canadensis</u>	Otter	NC
<u>Lynx rufus</u>	Bobcat	NC
<u>Sylvilagus floridanus</u>	Eastern cottontail	C
<u>Sylvilagus aquaticus</u>	Swamp rabbit	C
<u>Sciurus carolinensis</u>	Gray squirrel	C
<u>Sciurus niger</u>	Fox squirrel	C
<u>Odocoileus virginianus</u>	White-tailed deer	C

Small mammals are also found throughout the basin and like most wildlife are more common along ecotones or edges of two or more habitats. Levees and canal spoil banks provide much needed high ground for dens and nests. Populations studied in the fresh marshes around Lake Boeuf were found to be significantly higher along these spoil banks (Abernathy et al. 1985).

The furbearers are probably the single most important group of mammals in Barataria Basin. They make up the highest percentage of biomass, and more time is spent in their pursuit

than any other group of mammals found here. All the furbearers are common and widespread throughout the basin though their relative abundances vary between habitats. The muskrat (Ondatra zibethicus) is more common in the salt and brackish marsh than in the fresh-intermediate marsh (Greg Linscombe, LDWF Biologist, New Iberia, LA, pers. comm.; Palmisano 1973; Sasser et al. 1983; Abernathy et al. 1985). Nutria (Myocaster coypus) concentrations are considerably higher in the fresh marsh than in other wetlands while raccoon (Procyon lotor), mink (Mustela vison), and otter (Lutra canadensis) are

found in similar concentrations in all marsh types (Palmisano 1973). Opossum (Didelphus virginiana) and bobcat (Lynx rufus) are not common in the marshes but are found along ridges and levees primarily in the northern swamps and along the Mississippi River.

The five game animals present in Barataria Basin are found together in only one region. It is in the varied habitat of the cypress swamps, ridges, and farmland of northern Barataria Basin where a hunter may take gray and fox squirrels, (Sciurus carolinensis, S. niger) cottontails and swamp rabbits (Sylvilagus floridanus, S. aquaticus), and white-tail deer (Odocoileus virginianus). The white-tailed deer prefers the dry ridges and abandoned fields but does spread out into the floating marshes of Lake Boeuf and the stable fresh marshes north of Golden Meadow, Louisiana. Deer are also found along the Mississippi River levees south to the delta. The swamp rabbit is common and widespread in most habitats from Grand Isle to Donaldsonville. It survives in swamps to brackish marshes, but prefers at least some dry ground. Therefore it is most common along ridges, cheniers, and spoil banks. The squirrels inhabit the swamps and reach highest populations along the hardwood ridges and natural levees where mast-producing oaks (Quercus spp.) are found (Lowery 1974b).

### 8.3.2 Seasonal Abundance

Mammals are mostly year-round residents of the basin. Only a few species of bats migrate into or out of Louisiana during the winter. Some small mammals may hibernate during the coldest weeks of the year but the majority of species are active and visible throughout the year.

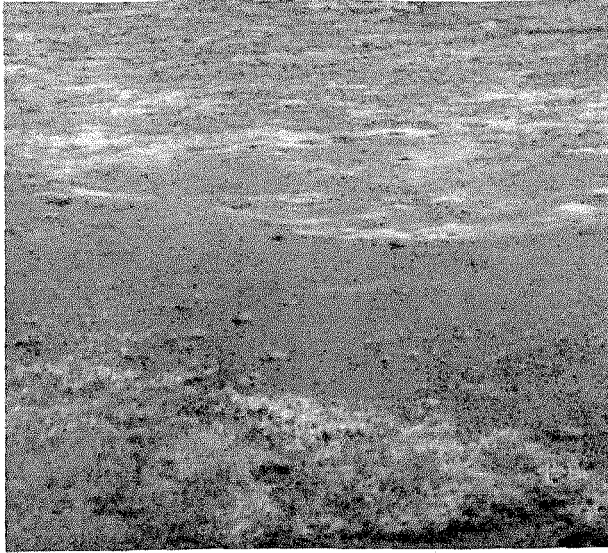
Negus et al. (1961) found that rice rat (Oryzomys palustris) populations in the brackish marshes of Breton Island, Louisiana, reached their lowest density in late winter and early spring. Populations increased throughout the summer and fall and began to decline after November. This decline in the fall was due to cessation of breeding and high mortality caused by the onset of bad weather. During relatively warm winters, Negus found that populations continued to increase through the winter. This population trend is similar in most mammal species. The onset of hunting and trapping activities contribute to the decline of some species through the fall and winter. For

species like the deer, otter, nutria, muskrat, and raccoon, man is a major predator, and animal numbers decrease throughout the season. But during spring the fecundity of these species is displayed as litters are born and their numbers again approach the carrying capacity of the marshes.

### 8.3.3 Food Habits

Mammals can be classified into three broad groups by their food habits: herbivores, first-order carnivores, and second-order carnivores. The herbivores, which feed primarily on plant material, are generally most common, have the largest and most frequent litters, and are near the bottom of the food chain. Rice rats, nutria, muskrat, and swamp rabbits are the most common herbivores. Rice rats are abundant throughout Barataria Basin and can produce up to seven litters between March and October with two to five young per litter (Lowery 1974b). The rice rat feeds primarily on seeds and plant materials but will shift to animal protein if it is available. Sharp (1967) found that rice rats in a Georgia salt marsh fed mostly on crabs, insects, and bird eggs throughout the summer. This prolific breeder is in turn preyed on by owls, hawks, snakes, and mink. The barn owl feeds on little else. Jemison and Chabreck (1962) found that 97.5% of the food of wintering barn owls on Marsh Island, Louisiana, was rice rats.

Nutria are abundant throughout the basin but generally reach their highest populations in the fresh marsh (Palmisano 1973). These 12 lb rodents feed on aboveground vegetation and can consume 2.5 to 3.5 pounds of food a day (Lowery 1974b). The muskrat, in contrast, eats 0.7 pounds of roots, tubers, and some above-ground vegetation per day. Its preferred food in the brackish marshes is Scirpus olneyi and when Scirpus is encouraged to grow through the controlled use of fire, dramatic increases in muskrat numbers often result (Lowery 1974b). Muskrats and nutria are extremely destructive to their habitats (Figure 46). Their burrowing and digging can cut up and destroy a great deal of marsh. Each muskrat house may have a diameter of 10 ft and may contain 20 bushels of marsh vegetation. In areas where the muskrat population increases well beyond the carrying capacity, the marsh itself can be destroyed. This is locally called an "eat-out" and the result to the population is starvation or emigration (Lynch et al. 1947).



**Figure 46.** Muskrat eat-out in Spartina patens marsh (photo by R. Abernethy).

Swamp rabbits are also quite common in all habitats except the salt marsh. They feed on most grasses, sedges, and emergent vegetation.

The bats are the most common first order carnivores of the basin. They catch and eat primarily flying insects. Barbour and Davis (1969) found that Brazilian free-tailed bats (Tadarida brasiliensis) nightly consumed 0.09 oz of insects apiece. They computed that this amounted to the destruction of 19,800 tons of flying insects a year in Texas.

The top mammal carnivores in Barataria Basin are also the most elusive. The raccoon, mink, and otter are found throughout the basin but in no location are they common. They are shy, secretive, and generally nocturnal. The otter is at home in the water and feeds mostly on fish, crabs, snakes, crayfish, frogs, and other aquatic animals. The mink and raccoon both prefer to hunt along the banks of bayous and ponds. The mink consumes the same food as the otter with the addition of birds and small mammals. The raccoon adds fruit, berries, mast, and buds to its list of animal protein. Once mature these top carnivores have little to fear except alligators and man in search of fur (Lowery 1974b).

### 8.3.4 Populations

Mammal populations vary widely between and within habitats. Nutria are most common in the fresh marsh with a coastwide average pelt production of 1.2 pelts/ha. The brackish marsh averages 0.37 pelts/ha while the saline marsh has nearly zero. Between 1977 and 1980 Linscombe et al. (1984) studied a nutria population in a brackish Spartina patens marsh in south-central Louisiana that he considered to have numbers greater than the carrying capacity of the land. It yielded 10.5 pelts/ha from a population of 24 nutria/ha.

Muskrat are most common in the Spartina patens brackish marshes. Harvests as high as 16 pelts/ha have been reported in some areas with a coastwide average of 0.2 pelts/ha. These brackish marsh populations seem to be cyclic; the fresh and intermediate marsh populations are much lower but also more stable, with maximum harvests approaching only 1.6 pelts/ha (Palmisano 1973).

Otter, mink, and raccoon are not nearly as common as nutria and muskrat. Mink production was a constant 0.03 pelts/ha in all habitats while raccoon catch was higher in the fresh marsh with a production of 0.77 pelts/ha (Palmisano 1973). This high production may have reflected more the higher price paid for fresh marsh raccoons than the actual population size. Otters were by far the most uncommon large mammal of the marshes. Average pelt production for all marsh types was approximately 0.001 pelts/ha.

## 8.4 REPTILES AND AMPHIBIANS

### 8.4.1 Distribution

More than 60 species of herpetofauna are found throughout the bottomland hardwood ridges, swamps, and marshes of Barataria Basin (Table 28). Snakes lead the list with 22 species, followed by 15 turtles, 11 frogs, 6 salamanders, 6 lizards, 4 sea turtles, 3 toads and the alligator (Dr. Douglas A. Rossman, LSU Museum of Natural History; pers. comm.).

The highest concentration and greatest species diversity is along the natural ridges and levees leading away from the Mississippi River and out into the cypress swamps that make up the

**Table 28.** Reptiles and amphibians of Barataria Basin (source: Dr. Douglas A. Rossman, LSU Museum of Natural History).

American alligator	<u>Alligator mississippiensis</u>
Alligator snapping turtle	<u>Macrolemys temmincki</u>
Snapping turtle	<u>Chelydra serpentina</u>
Stinkpot	<u>Sternotherus odoratus</u>
Mud turtle	<u>Kinosternon subrubrum</u>
Box turtle	<u>Terrapene carolina</u>
Diamondback terrapin	<u>Malaclemys terrapin</u>
Map turtle	<u>Graptemys kohni</u>
False map turtle	<u>Graptemys pseudogeographica</u>
Red eared turtle	<u>Pseudemys scripta</u>
Slider	<u>Pseudemys floridana</u>
Cooter	<u>Pseudemys concinna</u>
Painted turtle	<u>Chrysemys picta</u>
Chicken turtle	<u>Deirochelys reticularia</u>
Smooth soft shell turtle	<u>Trionyx muticus</u>
Spiny softshell	<u>Trionyx spiniferus</u>
Green anole	<u>Anolis carolinensis</u>
Ground skink	<u>Scincella lateralis</u>
Five-lined skink	<u>Eumeces fasciatus</u>
Broad-headed skink	<u>Eumeces laticeps</u>
Eastern Glass lizard	<u>Ophisaurus ventralis</u>
Slender Glass lizard	<u>Ophisaurus attenuatus</u>
Three-toed amphiuma	<u>Amphiuma tridactylum</u>
Lesser siren	<u>Siren intermedia</u>
Small mouthed salamander	<u>Ambystoma texanum</u>
Central newt	<u>Notophthalmus vividescens</u>
Southern dusky salamander	<u>Desmognathus auriculatus</u>
Dwarf salamander	<u>Eurycea quadridigitata</u>
Fowler's toad	<u>Bufo woodhousei</u>
Gulf coast toad	<u>Bufo valliceps</u>
Northern cricket frog	<u>Acris crepitans</u>
Northern spring peeper	<u>Hyla crucifer</u>
Green treefrog	<u>Hyla cinerea</u>
Squirrel treefrog	<u>Hyla squirella</u>
Gray treefrog	<u>Hyla chrysocelis-versicolor complex</u>
Bird-voiced treefrog	<u>Hyla avivoca</u>
Upland chorus frog	<u>Pseudacris triseriata</u>
Eastern narrow-mouthed toad	<u>Gastrophryne carolinensis</u>
Bull frog	<u>Rana catesbeiana</u>
Pig frog	<u>Rana grylio</u>
Bronze frog	<u>Rana clamitans</u>
Southern leopard frog	<u>Rana utricularia</u>
Atlantic green seaturtle	<u>Chelonia mydas</u>
Atlantic loggerhead	<u>Caretta caretta</u>
Atlantic ridley	<u>Lepidochelys kemp</u>
Atlantic leatherback	<u>Dermodochelys coriacea</u>
Green water snake	<u>Nerodia cyclopion</u>
Diamondback water snake	<u>Nerodia rhombifera</u>
Yellow-bellied water snake	<u>Nerodia erythrogaster</u>
Broad-banded water snake	<u>Nerodia fasciata</u>

Table 28. Concluded.

Gulf salt marsh snake	<u>Nerodia fasciata clarki</u>
Graham's water snake	<u>Regina grahami</u>
Delta glossy water snake	<u>Regina rigida</u>
Brown snake	<u>Storeria dekayi</u>
Eastern garter snake	<u>Thamnophis sirtalis</u>
Western ribbon snake	<u>Thamnophis proximus</u>
Eastern hognose snake	<u>Heterodon platyrhinos</u>
Ringneck snake	<u>Diadophis punctatus</u>
Western mud snake	<u>Farancia abacura</u>
Racer	<u>Coluber constrictor</u>
Rough green snake	<u>Opheodrys aestivus</u>
Texas rat snake	<u>Elaphe obsoleta</u>
Speckled kingsnake	<u>Lampropeltis getulus</u>
Louisiana milksnake	<u>Lampropeltis triangulum</u>
Southern copperhead	<u>Agkistrodon contortrix</u>
Western cottonmouth	<u>Agkistrodon piscivorus</u>
Western pygmy rattlesnake	<u>Sistrurus miliarius</u>
Canebrake rattlesnake	<u>Crotalus horridus</u>

northern part of Barataria Basin (Table 29; Mabie 1976). Along these islands of high, dry ground, many species find needed nesting areas and preferred basking and hibernation sites. Tinkle (1959) found the ridges were also useful as dispersal routes for species such as the racer (Coluber constrictor), speckled kingsnake (Lampropeltis getulus), and the Texas rat snake

(Elaphe obsoleta). He found 66.7% of the reptiles and amphibians on the ridge and only 3.1% in the surrounding gum-cypress swamp (Table 30). Other species common to the hardwood ridges are the cottonmouth (Agkistrodon piscivorus), green watersnake (Nerodia cyclopian), broad-banded watersnake (Nerodia fasciata), diamondback watersnake (Nerodia rhombifera), western ribbon

Table 29. The numbers of several species of reptiles encountered along spoil banks in 1974 (Mabie 1976).

Species	Habitat		
	Swamp	Spoil bank	Aquatic
American alligator	0	2	3
Green anole	2	21	0
Ground skink	0	15	0
Diamondback water snake	1	10	3
Ribbon snake	0	2	0
Speckled kingsnake	0	1	0
Eastern yellow-bellied racer	0	2	0
Western cottonmouth	2	12	3
Green treefrog	0	2	0
Five-lined skink	1	6	0
Green frog	2	23	10
<b>TOTAL</b>	<b>8</b>	<b>96</b>	<b>19</b>

Table 30. The numbers of reptiles and amphibians encountered along the main ridges or in the cypress-gum swamp of the Barataria Basin from November 1953 to December 1954 (Tinkle 1959).

Species	Habitat			
	Swamp	Ridge	Aquatic	Marsh
<u>Agkistrodon piscivorus</u>	25	23	6	19
<u>Anolis carolinensis</u>	8	96	3	104
<u>Coluber constrictor</u>	0	16	0	0
<u>Eumeces fasciatus</u>	2	53	0	1
<u>Hyla cinerea</u>	0	36	0	132
<u>Lampropeltis getulus</u>	0	15	0	0
<u>Microhyla carolinensis</u>	0	78	0	2
<u>Natrix cyclopion</u>	0	0	12	6
<u>Natrix sipedon</u>	6	6	25	12
<u>Rana clamitans</u>	15	675	7	165
<u>Thamnophis sauritus</u>	2	180	8	31
<b>TOTALS</b>	<b>58</b>	<b>1,178</b>	<b>61</b>	<b>472</b>



snake (Thamnophis proximus), green anole (Anolis carolinensis), five-lined skink (Eumeces fasciatus), ground skink (Scincella lateralis), green treefrog (Hyla cinerea; Figure 47), eastern narrow-mouthed toad (Gastrophryne carolinensis), and bronze frog (Rana clamitans) (Tinkle 1959; Mabie 1976).

The second highest concentration of herpetofauna is found in the fresh and intermediate marshes. Here, too, the animals are more common along spoil banks and levees than in the marsh proper and for many snakes, turtles, and the American alligator (Alligator mississippiensis), this is the preferred habitat (Table 31).

In June 1982, three transects were run in the swamp and fresh marsh bayous around Lake Boeuf. In 30 mi, 106 alligators were counted for an average of 3.5 alligators/mi (Sasser et al. 1983). In 1983 a survey of Lake Boeuf recorded 454 alligators around the 7-mi shoreline (Sasser et al. 1984). This average of 64.9 alligators/mi cannot be compared with the previous survey because of the different widths of the transects. But the lake survey does show that alligators are extremely abundant in certain habitats.

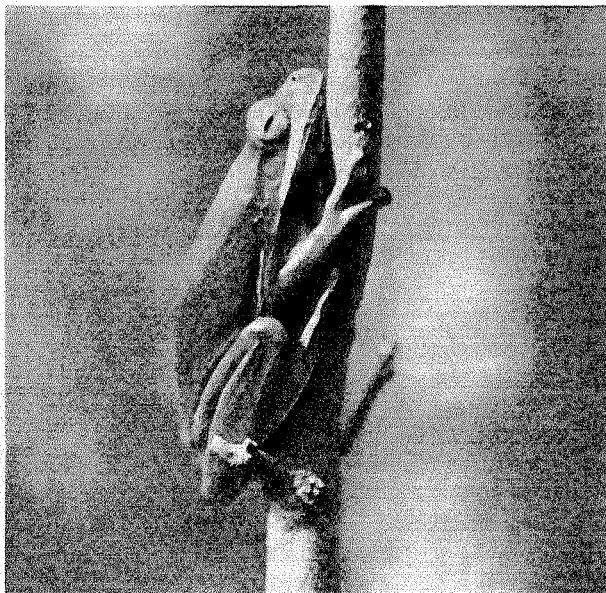


Figure 47. Green tree frog (photo by W. Conner).

Few reptiles and amphibians prefer a saline environment (Mabie 1976). The only species found commonly in salt marsh environments are the salt marsh snake (Nerodia fasciata clarki), the gulf coast toad (Bufo valliceps), and the diamondback terrapin (Malaclemys terrapin) (Mabie 1976).

Four sea turtles, the Atlantic green sea turtle (Chelonia mydas), Atlantic loggerhead (Caretta caretta), Atlantic ridley (Lepidochelys kempfi), and the Atlantic leatherback (Dermochelys coriacea) also visit the offshore waters of the barrier islands of Barataria Basin (Rossman; pers. comm.).

#### 8.4.2 Food Habits

Most species of herpetofauna are carnivorous or omnivorous. Turtles feed primarily on fish, crustaceans, mollusks, insects, invertebrates, and vegetation. Lizards, salamanders, frogs, and toads consume insects and spiders. Snakes eat almost any animal they can catch, with fish, frogs, salamanders, lizards, snakes, tadpoles, crawfish, insects, rodents, small birds, and bird eggs making up the bulk of their diet (Conant 1975). The alligator, the largest reptile in Louisiana, feeds primarily on crawfish. Chabreck (1971) estimated 61% of the alligator's diet in freshwater habitats was crawfish. In brackish water, blue crabs (Callinectes sapidus) make up 50% of the diet. Alligators also feed on birds, fiddler crabs (Uca pugnax), fish, insects, muskrats, turtles, shrimp, snails, snakes, nutria, and some grasses (Valentine et al. 1972; Table 32).

#### 8.4.3 Populations

In 1985, an intensive helicopter search was made for alligator nests around Lake Boeuf (Sasser et al. unpubl. data; Figure 48). One hundred twenty active nests were located in the 3,645-ha marsh. Chabreck (1966) found that 5% of the total population was nesting females. From this figure, a population estimate at Lake Boeuf of 2,400 alligators or one alligator/1.5 ha can be calculated. Joanen and McNease (1982) found one alligator/8.0 ha in the marshes as a whole. They found one alligator/3.2 ha in the intermediate marsh, and one/5.7 ha in the fresh and brackish marshes. Few were found in the salt marsh.

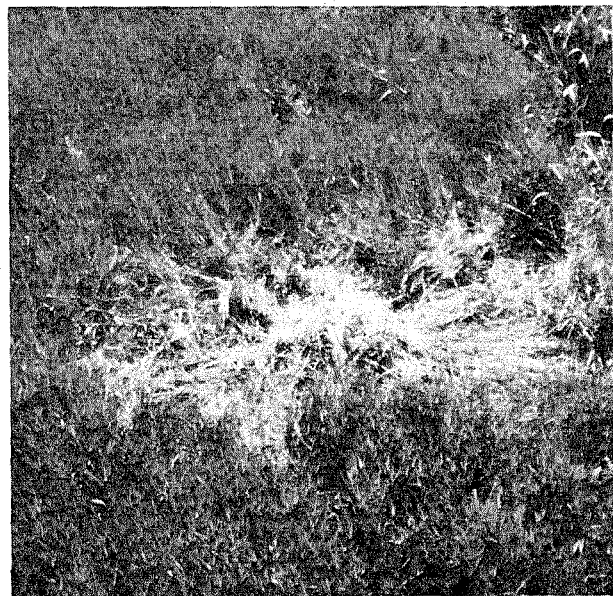


**Table 31.** Coastal alligator population estimates according to marsh zones and marsh types, averaged for 1970 and 1977 and expressed as a percentage (after McNease and Joanen 1978).

Marsh type	Marsh zones			Population by marsh type
	Chenier Plain	Subdelta	Active delta	
Fresh	21.6	13.4	2.5	37.5
Intermediate	22.9	6.5	2.5	31.9
Brackish	16.2	14.1	0.4	30.7
Total by area/marsh zone	60.7	34.0	5.4	

**Table 32.** Stomach contents of alligators (given as average percentage of the volume and average percentage of occurrence) from the Sabine National Wildlife Refuge. (Giles and Childs 1949; Valentine et al. 1972).

Food item	Volume(%)	Occurrence(%)
Crustacean	18	70
Fish	23	34
Reptiles and amphibians	7	21
Birds	14	16
Mammals	26	32
Insects	10	15
Plant material	<1	32
Miscellaneous (stones, shells, mud, etc.)	2	33
Empty	0	3



**Figure 48.** Alligator nest in fresh marsh around Lake Boeuf (photo by R. Abernethy).

## 8.5 ENDANGERED SPECIES

Louisiana has 14 species of endangered or threatened birds, mammals, and reptiles (USFWS, Office of Endangered Species, Jackson, Miss.). Of these 14, 8 may be found in Barataria Basin.

### 8.5.1 Brown Pelican

Historically, brown pelicans were common throughout coastal Louisiana and the northern Gulf of Mexico. Breeding colonies were located on Isles Dernieres, East Timbalier Island, the Chandeleurs, and the mouth of the Mississippi. In 1956, 20 to 25 dead adults were noted around Dauphin and Petit Bois Islands in Alabama and

Mississippi, and 50 dead adults were found on the Chandeleurs. Populations declined rapidly thereafter, and by 1962 no nesting occurred in Louisiana (Lowery 1974a).

The problem was nationwide, and chlorinated hydrocarbons used in pesticides, such as DDT and endrin, were found to be the cause. The chemicals leached off farmland with rain water and flowed into streams and rivers. Fish picked up the poison and the pelicans ate the fish. The chemicals concentrated in the birds' fat tissues and during times of stress, such as cold weather, or storms, the fat was used and the chemicals released into the birds' systems. Not only were

adults killed, but the ones that survived were unable to reproduce. Eggs were laid with shells so thin that they broke under the weight of the incubating parent.

In 1968, the Louisiana Department of Wildlife and Fisheries released at Grand Terre Island in Barataria Bay 15 pelicans captured in Florida and 15 more at Rockefeller Refuge in southwest Louisiana. The practice continued and the Grand Terre birds thrived while the Rockefeller birds disappeared. In 1973, there were an estimated 400 birds in Barataria Bay. Brown pelicans were again seen from the Chandeleurs to Timbalier (Lowery 1974a).

Today, the brown pelican continues to increase. There is an estimated population of 2,000 birds in two colonies: one in Barataria Bay and one on North Island in the Chandeleurs. Though still endangered they seem to be out of immediate danger (McNease, pers. comm.).

#### 8.5.2 Bald Eagle

The bald eagle, always an uncommon raptor of the Southeast, has become extremely rare in the last 50 years because of pesticide poisoning and illegal shooting. Yet, Dugoni (1980) located 29 bald eagle eyries in south Louisiana. Thirteen were occupied in 1978-79, and of these, four were in Barataria Basin. Dugoni found annual production to be 0.94 young produced per active nest, which suggests that the population may be stable.

Birds, primarily waterfowl and coots, make up 42% of the eagles' diets, while fish supply 42% and mammals 16%. Bald eagles are most often considered fish eaters, but this preponderance of waterfowl in the diet may be explained by the large amount of sport hunting that takes place in south Louisiana, and the resulting availability of lost and crippled birds (Dugoni 1980).

#### 8.5.3 Bachman's Warbler (Vermivora bachmanii)

America's rarest warbler is a breeder in heavily wooded swamps and bottomlands, and until the 1890's Bachman's Warbler was locally common in south Louisiana. Stuffed specimens often turned up in the millinery trade as colorful adornments on ladies hats. The population

declined for no apparent reason but may still be found occasionally throughout the southeast.

#### 8.5.4 Peregrine Falcon (Falco peregrinus)

A rare winged visitor of Barataria Basin's gulf shores, this large, powerful falcon is most often observed over marshes, mud flats, and beaches during migration where it feeds on shorebirds and waterfowl. Its decline, like the brown pelican's, was primarily caused by the weakening of eggshells by chlorinated hydrocarbons (Lowery 1974a).

#### 8.5.5 Sea Turtles

Of the four species of sea turtles found in Louisiana waters, two, the Atlantic green sea turtle and the Atlantic loggerhead turtle, are listed as threatened (USFWS, Office of Endangered Species, Jackson, Miss.). The Atlantic ridley and Atlantic leatherback are listed as endangered.

Sea turtles do not nest in Barataria Basin, but as late as 1962, Atlantic loggerheads, the most common sea turtle in the northern gulf, still nested on the Chandeleur Islands, east of the Mississippi River (Ogren 1977 in Fuller 1980). Fritts et al. (1983) conducted five bimonthly flights from June 1980 to April 1981 south of Marsh Island, Louisiana. They counted 15 Atlantic loggerhead turtles, and 2 Atlantic leatherback turtles, but no Atlantic green sea turtles or Atlantic ridley turtles.

Two major factors that have decimated all species throughout the gulf have been exploitation for food and nesting habitat loss to seaside development. Turtles are also caught in nearshore shrimp trawls. In 1977, 26 Louisiana shrimpers fished 5,345 days and caught 102 sea turtles of which 24% died before they could be freed (Fuller 1980).

### 8.6 HUNTING AND TRAPPING

Wildlife is extremely important to the people of Louisiana and the Barataria Basin. Game species provide 400,000 hunters with 7,486,000 person-days of recreation each year on a statewide basis (LDWF 1983). Much of this hunting takes place on private land or on three state wildlife management areas which total some 119,000 acres in Barataria Basin (Brunett and Willis 1981).

The most sought after group of animals in Barataria Basin is probably waterfowl. In 1983, hunters in Barataria Basin harvested over 210,000 waterfowl, or 10%, of the statewide harvest of 2,270,000 birds. To put these figures into national perspective, this kill of 210,000 in the basin was higher than the kills of 30 States.

The bottomland hardwoods and swamps of northern Barataria Basin have excellent hunting for squirrel, rabbit, and whitetailed deer. Some good public deer hunting exists in the fresh marshes of Salvador Wildlife Management area. This 31,000-acre area, 20 mi. southeast of New Orleans, is accessible only by boat.

While game species are sought primarily for sport and recreation, furbearers provide partial employment for 12,000 trappers statewide and income of over \$20 million in addition to the recreational aspects (Joanen and McNease 1982). Zeringue (1980) reported the six most commonly taken fur species in the northern Barataria Basin to be nutria, muskrat, raccoon, skunk, opossum, and otter. They yielded 99,000 pelts and provided trappers with an income of \$446,000 in 1977.

The most common furbearer, the nutria, yielded over 77,000 pelts. Nutria were first

introduced into Louisiana from South America in the late 1930's and spread quickly to all freshwater aquatic habitats in the state. Today, it is one of the most common mammals of the state and can be seen along nearly every stream and bayou and in every fresh marsh and swamp in Barataria Basin. The nutria is the backbone of the Louisiana fur industry, annually contributing over 50% of the total harvest (Linscomb and O'Neil 1982).

One species that has increased from endangered status to the point of abundance is the American alligator. Populations have increased to such a point that there is now a rigidly controlled harvest statewide. In 1984, alligator trappers harvested over 4,000 animals from Barataria Basin alone (N. Kinler, Biologist, La. Dept. Wildl. Fish., New Iberia, Louisiana; pers. comm.).

Hunting and trapping are extremely important activities in the basin today and along with sport fishing are the most important recreational activities. Although the popularity of bird watching, photography, nature watching, and camping are ever increasing in Barataria Basin, hunting, trapping and sport fishing (i.e., the consumptive use of wildlife resources) remain the most important reasons people enter the Barataria Basin.

# CHAPTER 9

## REVIEW OF MODELING STUDIES IN THE BARATARIA BASIN

by

R. Costanza

### 9.1 INTRODUCTION

The Barataria Basin has been the focus of several mathematical modeling studies aimed at improved quantitative understanding of the physical, biological, and socioeconomic behavior of the region. Eight modeling studies are reviewed in this chapter. Because the Barataria Basin is made up almost entirely of wetlands and open water systems, hydrology is an important component in all of the models. Two hydrodynamic models aimed at simulating the detailed water flow in the region have been produced (Stone and McHugh 1979; Hopkinson and Day 1980b). Other models have incorporated hydrology in a less detailed way as a major determinant of plant and animal behavior (Hopkinson and Day 1977; Sklar et al. 1983; Costanza et al. 1983). A third group of models concentrated on long term succession and land use change caused by human actions, mainly as they affect hydrology (Eckenrod et al. 1979; Hopkinson and Day 1980a; Cleveland et al. 1981). In this chapter, each of these modeling efforts is briefly reviewed, pointing out the major purpose of each study and its results (along with problems, limitations, and suggestions for further research).

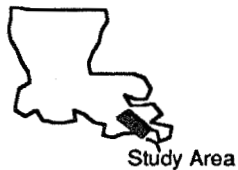
### 9.2 HYDRODYNAMIC MODELS

Hydrodynamic models simulate the physics of water movement. They have become popular and effective tools for storm water management and other applications that require simulating the detailed, short term behavior of hydrologic systems. The EPA Storm Water Management Model (Environmental Protection Agency 1971) is a popular example of this type of

model. More recently, this type of model has been applied to natural hydrologic systems (particularly wetlands and open water areas) in order to understand the way water moves in these systems, and to investigate the impacts of proposed changes (Hopkinson and Day 1980b; Gael 1980; Stone and McHugh 1979; Wang in press).

Two major hydrodynamic modeling studies have been completed in the Barataria Basin (Stone and McHugh 1979; Hopkinson and Day 1980b). Stone and McHugh were concerned with modeling the Barataria system to predict the impacts of human modifications that affect hydrology, and with the general question of assessing the usefulness of hydrodynamic modeling for large diverse coastal wetlands. In particular, they were concerned with assessing the impacts of oil and gas access and navigation canals on regional hydrology in the lower Barataria Basin (Figure 49). Figure 50 is a summary of the model results for five alternatives with increasing extent of canals and spoil banks. The model results indicated some increased flooding in the northern part of the basin due to surface flow restrictions, with slightly reduced water levels in the major water bodies as canal extent increases. In the southern part of the basin, there was increased water flow with the addition of more extensive canal systems.

This study demonstrated the feasibility and importance of hydrodynamic modeling in wetlands. It had several important limitations that need to be addressed in future hydrodynamic modeling, however. Only tides were used as a forcing function on water movement (wind and rain







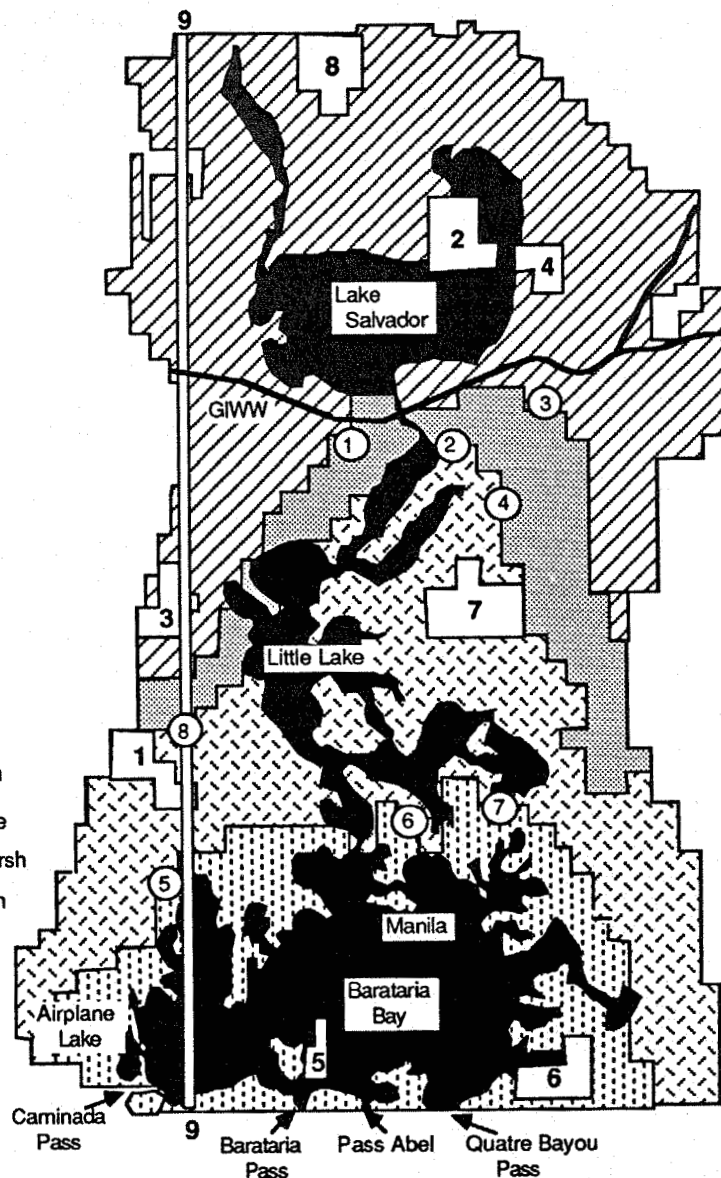
① Water Exchange Sites

**Oil and Gas Fields**

1. Golden Meadow Farms
2. Bayou Couba
3. Clovelly
4. Couba Island
5. Mendicant Island
6. Lake Washington
7. Lafitte
8. Des Allemands
9. LOOP Canal

**Vegetative Zones**

-  Zone 4- Fresh Marsh
-  Zone 3- Intermediate
-  Zone 2-Brackish Marsh
-  Zone 1-Saline Marsh



**Figure 49.** Grid locations for vegetative zones, water exchange lines, water level measurements, and oil and gas field activities. The area depicted lies between the Gulf of Mexico and the freshwater wetlands northwest of Lake Salvador (Stone and McHugh 1979).

were ignored), and the model was not verified extensively. Only three field stations were available for checking the model results. These correlated with model output with an average  $R^2$  of 0.67, but with only three points it is not possible to say anything meaningful about the accuracy of the model's performance. Future applications can take advantage of the more extensive hydrologic data base that has accumulated since the Stone and McHugh study was completed.

Hopkinson and Day (1980b) were concerned with the effects of hydrodynamics on nutrient dynamics and eutrophication in the swamp forest system in the upper basin. As in the Stone and McHugh study, the impacts of canals and spoil banks on water (and thus nutrient) movement was an important question. Figure 51 shows the results of Hopkinson and Day's application of the EPA SWMM model to the area shown in the figure. Runs 1 and 2 were based on present hydrologic

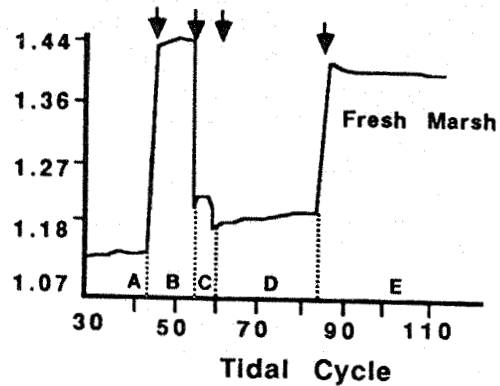
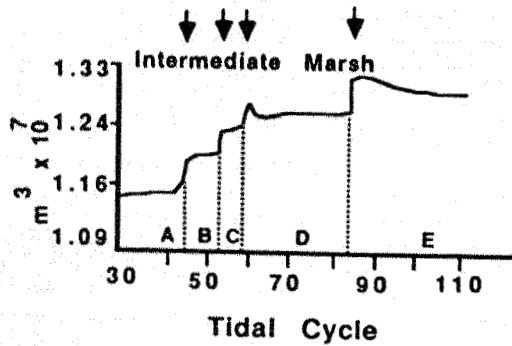
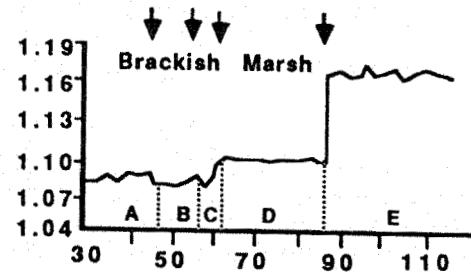
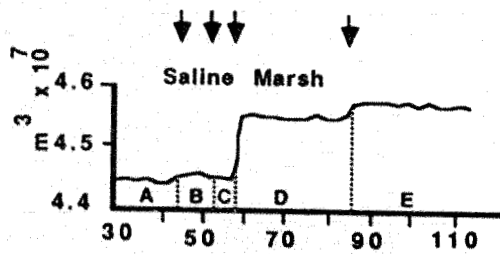
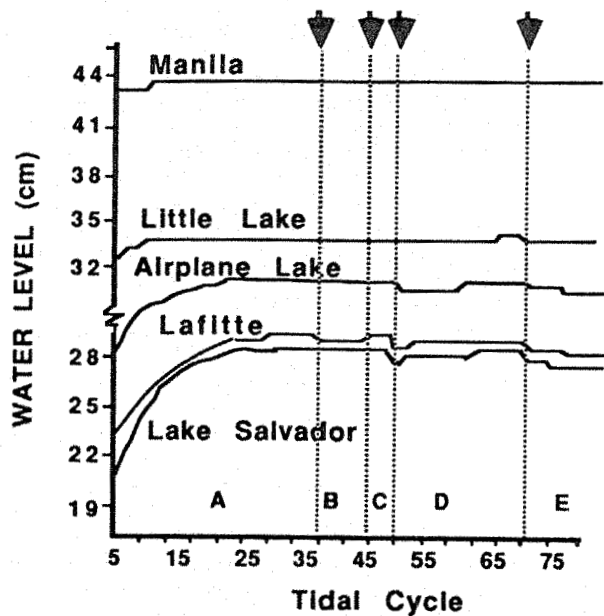
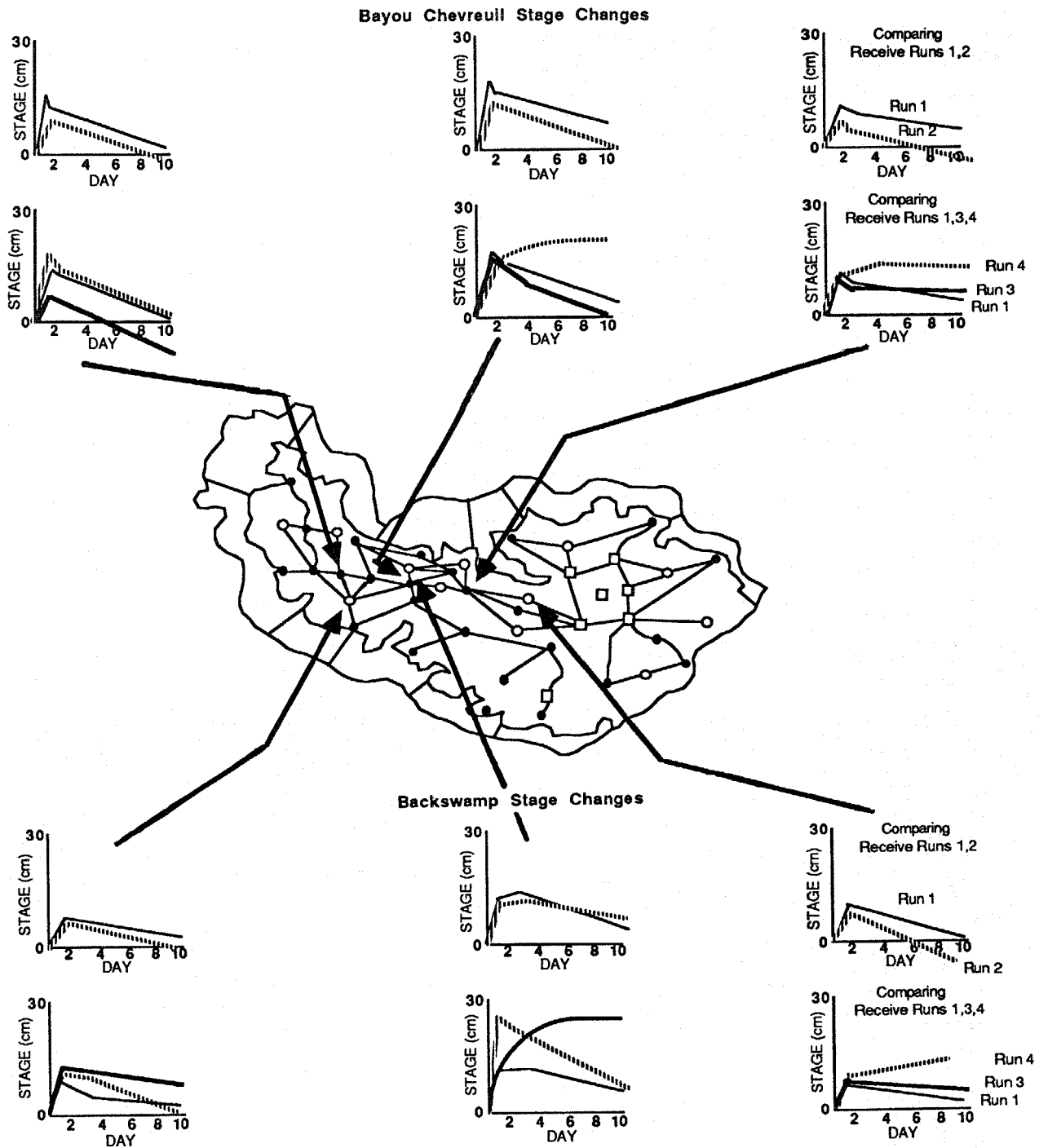


Figure 50. Water level changes at five locations (upper graph) and water per tidal cycle in each vegetation zone (lower graphs) with increasing extent of canals and spoil banks. A = with Intracoastal and Barataria Waterways and levees, B = with Intracoastal and Barataria Waterways but no levees, C = all waterways and levees, D = C plus eight oil and gas complexes, and E = D plus LOOP pipeline (Stone and McHugh 1979).



**Figure 51.** Hydrographs at selected stream and backswamp areas. Run 1 was current hydrologic conditions and low initial water levels. Run 2 was the same hydrologic conditions as run 1 but with initial water levels 30 cm higher (which was higher than spoil bank elevations). Run 3 simulated spoil bank removal in many places with other conditions identical to run 1. Run 4 simulated removal of all spoil banks, the closure of major upland drainage canals, and rerouting of upland runoff through the swamp via overland flow. Initial water levels were the same as run 1 (reprinted, with permission, from Hopkinson and Day 1980a, copyright Springer-Verlag).

conditions with low and high initial water levels respectively. Run 3 is the effect of manmade levee removal while Run 4 is the effect of levee removal and redirection of overland flow directly into the swamp rather than through canals. Results predicted that removal of the levees and introduction of upland drainage directly into the swamp (run 4) would increase discharge rates from the upper basin to the lower estuary, increase productivity of the swamp, and decrease eutrophication. Again, it is difficult to attach a confidence estimate to these model predictions, since only 11 field measurements were available for comparison with the model results. These measurements did not compare extremely favorably with the model results ( $R^2=0.37$ ). The forcing functions in this application were limited to upland runoff and rainfall. Wind and tides were ignored, but they are probably negligible in the upper basin because of the extensive tree cover and the distance from the coast. These omissions were therefore less important than those in the Stone and McHugh example.

The general lessons learned from the hydrodynamic modeling studies might be summarized as follows.

1. Hydrology in the Barataria Basin is a critical factor affecting nutrient concentrations, eutrophication, and ecosystem productivity.
2. Hydrodynamic modeling is essential to quantify and predict water movement, which forms the basis for most other material transport in wetland systems. The models that have been implemented thus far have been useful for improving understanding of the fundamental hydrologic questions.
3. Hydrodynamic models highlight the potential effects of canals and levees on water movement and related variables. These potential effects include eutrophication, localized flooding, and marsh and swamp deterioration.
4. The system is very complicated and there are few field measurements, so model testing is not very effective at present.
5. More field observations are needed.

### 9.3 ECOSYSTEM MODELS

A second type of model that has been applied to the Barataria Basin deals with entire ecosystems. These models can be divided into ones that are mainly static budgets of materials and

energy flows (Costanza et al. 1983) and those that are dynamic simulations (Hopkinson and Day 1977; Sklar et al. 1983).

#### 9.3.1 Static Material and Energy Budgets

Material and energy budgets have long been important tools in ecological research (Lindemann 1942; Odum 1957). They are used to quantify the connections between system components. This cataloging of interactions can be used to compare the system with other similarly cataloged systems, to highlight areas where data is strong and weak, and as a necessary precursor to dynamic simulation modeling. In this last regard, the dynamic modeling studies to be discussed later also included static budgets as data collection tools, but only the dynamic modeling portion of the studies will be discussed.

Simple material budgets have been a part of many studies in the Barataria Basin. For example, Figure 52 is a nutrient budget for the Lac des Allemands swamp (Day et al. 1977). More elaborate budgets that combine information on several nutrients, biomass types, and energy--called ecosystem input-output (I-O) tables -- have been assembled for the Lac des Allemands cypress swamp and for the Barataria salt marshes (Costanza et al. 1983). Table 33 is the salt marsh I-O table. The materials and energy being exchanged (commodities) are listed along the left of the table, and the "processes" in which these commodities are transformed are listed along the top. Each intersection of a commodity row and process column can contain up to three entries. The top entry is the input of the commodity to the process (i.e., the input of total organic matter to shallow soil/sediments in Table 33 is 1,602.5 g/m<sup>2</sup>/yr), the middle entry is the output of the commodity from the process (i.e., 5,608.4 g/m<sup>2</sup>/yr organic matter resuspended from shallow soil/sediments), and the bottom entry is storage of the commodity in the process (i.e., 1.74x10<sup>4</sup> g/m<sup>2</sup>/yr of organic matter stored in shallow soil/sediments).

In addition to their use as data summaries and tools for comparing ecosystems, I-O tables like Table 33 can potentially be used to calculate economic values ("shadow prices") for ecological commodities that do not have suitable market prices. These values can be useful as a common denominator linking ecological and economic



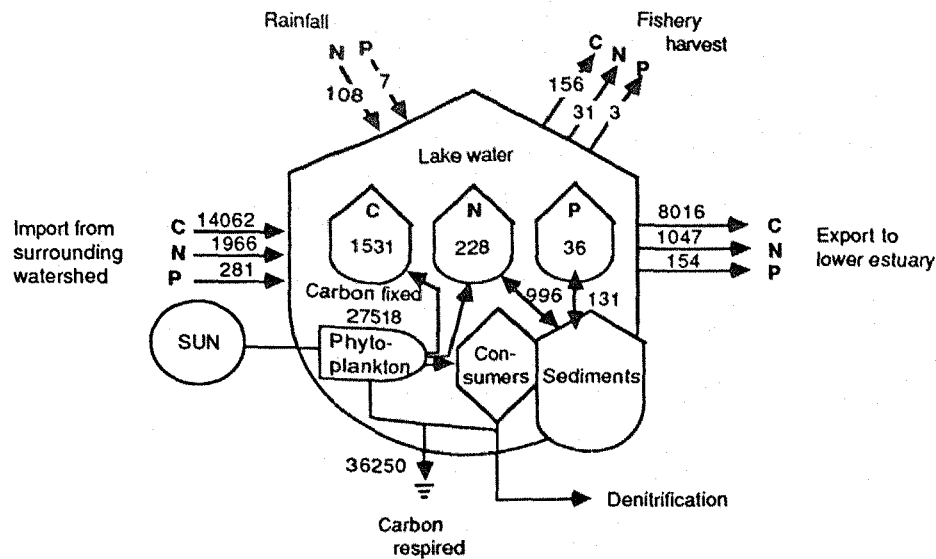


Figure 52. Nutrient budget for Lac des Allemands (reprinted, with permission, from Day et al. 1977, copyright Academic Press).

systems and aiding in the formulation of ecosystem management strategies (Costanza et al. 1983; Bahr et al. 1983; Costanza and Neill 1984).

### 9.3.2 Dynamic Simulation Models

Static budgets do not address the complex dynamic behavior of ecosystems. To predict how ecosystems will respond to stresses over time it is necessary to construct dynamic simulation models. Odum (1983) provides a recent summary of ecosystem simulation studies. Two major ecosystem simulation studies have been completed in the Barataria Basin. One is a model of the Barataria salt marshes (Hopkinson and Day 1977); the other is a model of a cypress swamp in the upper basin (Sklar et al. 1983).

A diagram of the Hopkinson and Day (1977) model is shown in Figure 53, along with some representative results. This model was concerned mainly with predicting the productivity of *Spartina alterniflora* as a function of variations in the input of sunlight, nutrients, and fresh and salt water, and with evaluating the relative contributions of marsh versus aquatic phytoplankton productivity to supporting aquatic fauna. The results shown in Figure 53 indicate that the model did a fairly good job of replicating observed data, but also that the data contained considerable

variation. The model was run alternately eliminating production from the marsh and the water column in order to test the relative importance of these two components as primary food sources. Elimination of aquatic primary production had a somewhat more dramatic effect on aquatic fauna than elimination of marsh production (56% reduction in mean standing crop vs. 36%).

This model also served (through sensitivity analyses) to highlight the importance of inorganic nitrogen, temperature, and annual sea level variations on primary and secondary productivity. As with most modeling studies, this one raised more questions than it answered. In particular, more accurate and more frequent measurements of critical parameters are needed to improve the resolution of the model and produce more detailed and accurate time responses.

The Sklar et al. (1983) simulation model of a cypress swamp was developed to predict the response of an impounded swamp habitat to various management options concerning the swamp's hydrologic regime. A diagram of the model and representative results are shown in Figure 54. The model consisted of 7 simultaneous nonlinear differential equations for state variables that included floating vegetation and consumers, benthic detritus and consumers, and aquatic

Table 33. Example of habitat input-output table for a salt marsh ecosystem (from Bahr et al. 1983).

COMMODITIES	PROCESSSES											
	Surface	Shallow soft sediments	Microflora	S. alterniflora macrophytes	Crabs	Mussels	Littorina	Insects	Birds	Mammals	Harmful invertebrates	Total
Organic nitrogen	Input 21.30	Output 21.30	Input 22.22	Output 22.22	Input 26.60	Output 26.60	Input 11.50	Output 11.50	Input 14.00	Output 14.00	Input 1.60	Output 1.60
Inorganic phosphorus	Input 2.80	Output 2.80	Input 16.00	Output 16.00	Input 2.20	Output 2.20	Input 5.40	Output 5.40	Input 0.50	Output 0.50	Input 2.80	Output 2.80
Inorganic carbon	Input 34.80	Output 34.80	Input 2.80	Output 2.80	Input 1.80	Output 1.80	Input 0.20	Output 0.20	Input 0.20	Output 0.20	Input 0.50	Output 0.50
Other nutrients	Input 1,023.00	Output 1,023.00	Input 286.50	Output 2,441.10	Input 1,638.40	Output 905.90	Input 65.80	Output 2,441.10	Input 286.50	Output 2,441.10	Input 1,638.40	Output 905.90
Total organic matter	Input 2,560.00	Output 1,602.50	Input 5,608.40	Output 17,000.00	Input 1,518.00	Output 647.10	Input 595.70	Output 630.50	Input 71.60	Output 476.30	Input 466.60	Output 647.10
Inorganic sediments	Input 2,113.60	Output 2,113.60	Input 2,113.60	Output 2,113.60	Input 175.30	Output 175.30	Input 1,938.30	Output 17,000.00	Input 17,000.00	Output 17,000.00	Input 1,938.30	Output 17,000.00
Water	Input 1,510,000.00	Output 1,510,000.00	Input 740,794.00	Output 63,892.00	Input 368,610.00	Output 308,292.00	Input 42,000.00	Output 42,000.00	Input 2,113.60	Output 6,340.80	Input 6,340.80	Output 42,000.00
Microflora biomass	Input 62,000.00	Output 114,000.00	Input 1,510,000.00	Output 740,794.00	Input 63,892.00	Output 368,610.00	Input 308,292.00	Output 42,000.00	Input 42,000.00	Output 176,000.00	Input 176,000.00	Output 4,500,000.00
S. alterniflora biomass	Input 1,377.00	Output 2,600.00	Input 1,191.00	Output 15.90	Input 16.10	Output 2,600.00	Input 57.20	Output 406.00	Input 406.00	Output 176,000.00	Input 176,000.00	Output 1,510,000.00
Other macrophytic biomass	Input 933.00	Output 777.80	Input 10.80	Output 10.90	Input 1.50	Output 29.00	Input 1,763.00	Output 702.00	Input 2,600.00	Output 2,600.00	Input 2,600.00	Output 702.00
Latex biomass	Input 1,695.90	Output 2,354.60	Input 266.10	Output 393.60	Input 2,354.60	Output 2,354.60	Input 2,354.60	Output 2,354.60	Input 2,354.60	Output 2,354.60	Input 2,354.60	Output 2,354.60
Macroconsumer biomass	Input 794.00	Output 794.00	Input 794.00	Output 794.00	Input 794.00	Output 794.00	Input 794.00	Output 794.00	Input 794.00	Output 794.00	Input 794.00	Output 794.00
Crab biomass	Input 2.00	Output 2.00	Input 18.00	Output 20.10	Input 20.10	Output 5.30	Input 18.00	Output 20.10	Input 20.10	Output 20.10	Input 20.10	Output 2.00
Mussel biomass	Input 84.90	Output 92.80	Input 5.90	Output 2.90	Input 2.90	Output 5.90	Input 5.90	Output 2.90	Input 2.90	Output 5.90	Input 5.90	Output 84.90
Littorina biomass	Input 24.10	Output 56.40	Input 24.10	Output 56.40	Input 56.40	Output 24.10	Input 24.10	Output 56.40	Input 56.40	Output 24.10	Input 56.40	Output 24.10
Insect biomass	Input 2.30	Output 26.30	Input 2.30	Output 26.30	Input 26.30	Output 2.30	Input 2.30	Output 26.30	Input 26.30	Output 2.30	Input 26.30	Output 2.30
Bird biomass	Input 0.10	Output 2.50	Input 0.10	Output 2.50	Input 2.50	Output 0.10	Input 0.10	Output 2.50	Input 2.50	Output 0.10	Input 2.50	Output 0.10
Mammal biomass	Input 1.50	Output 0.06	Input 0.08	Output 0.06	Input 0.06	Output 0.08	Input 0.06	Output 0.08	Input 0.08	Output 0.06	Input 0.06	Output 1.50
Fish biomass	Input 0.40	Output 1.60	Input 0.40	Output 1.60	Input 1.60	Output 0.40	Input 0.40	Output 1.60	Input 1.60	Output 0.40	Input 1.60	Output 0.40
Herb	Input 15.10	Output 15.10	Input 15.10	Output 15.10	Input 15.10	Output 15.10	Input 15.10	Output 15.10	Input 15.10	Output 15.10	Input 15.10	Output 15.10
Sunlight	Input 46,745.00	Output 366,686.00	Input 248,626.00	Output 44,966.00	Input 354,372.00	Output 240,277.00	Input 7,273.20	Output 68.90	Input 235.10	Output 493.80	Input 74.00	Output 82.90
Storage	Input 760,000.00	Output 1,420,000.00	Input 648,001.00	Output 648,001.00	Input 648,001.00	Output 158.50	Input 15.10	Output 15.10	Input 15.10	Output 15.10	Input 15.10	Output 15.10

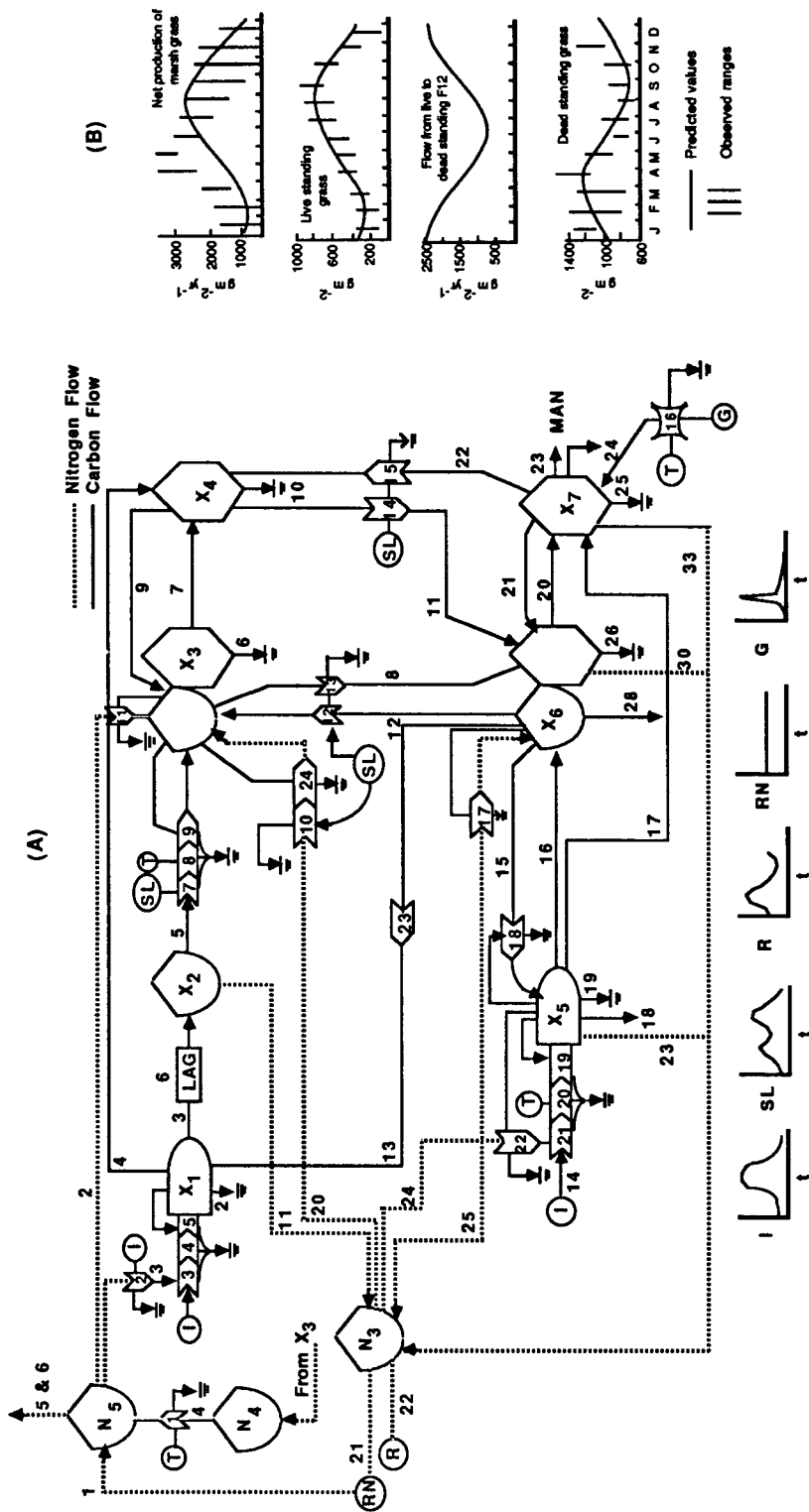


Figure 53. A simulation model of the Barataria salt marshes (A) with predicted values and observed ranges for reservoirs and flows of carbon (B). In the simulation model I = insolation, SL = sea level, T = temperature, R = river, RN = rain, G = migration from the Gulf of Mexico, and t = one year (reprinted, with permission, from Hopkinson and Day 1979, copyright John Wiley and Sons, Inc.).

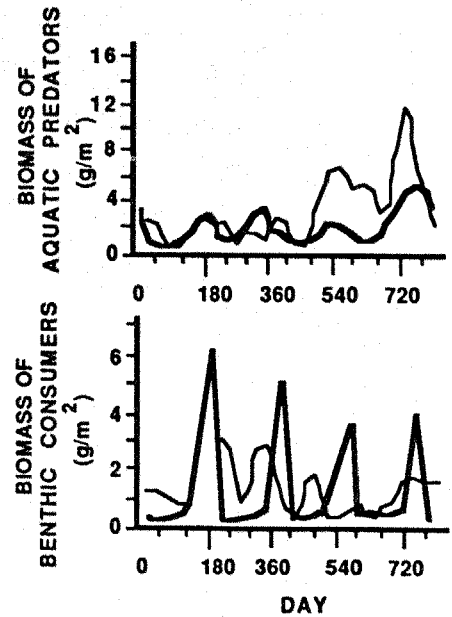
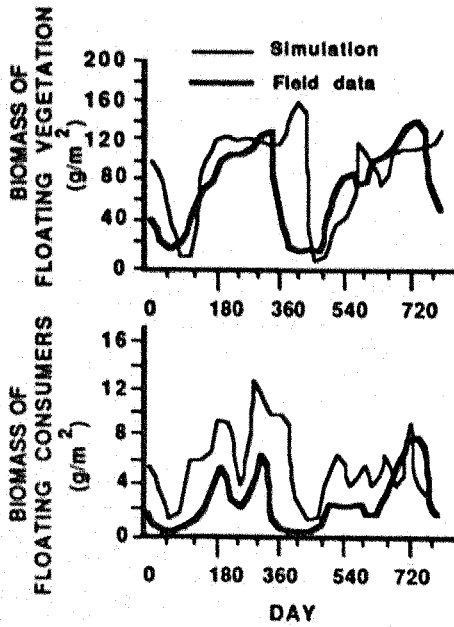
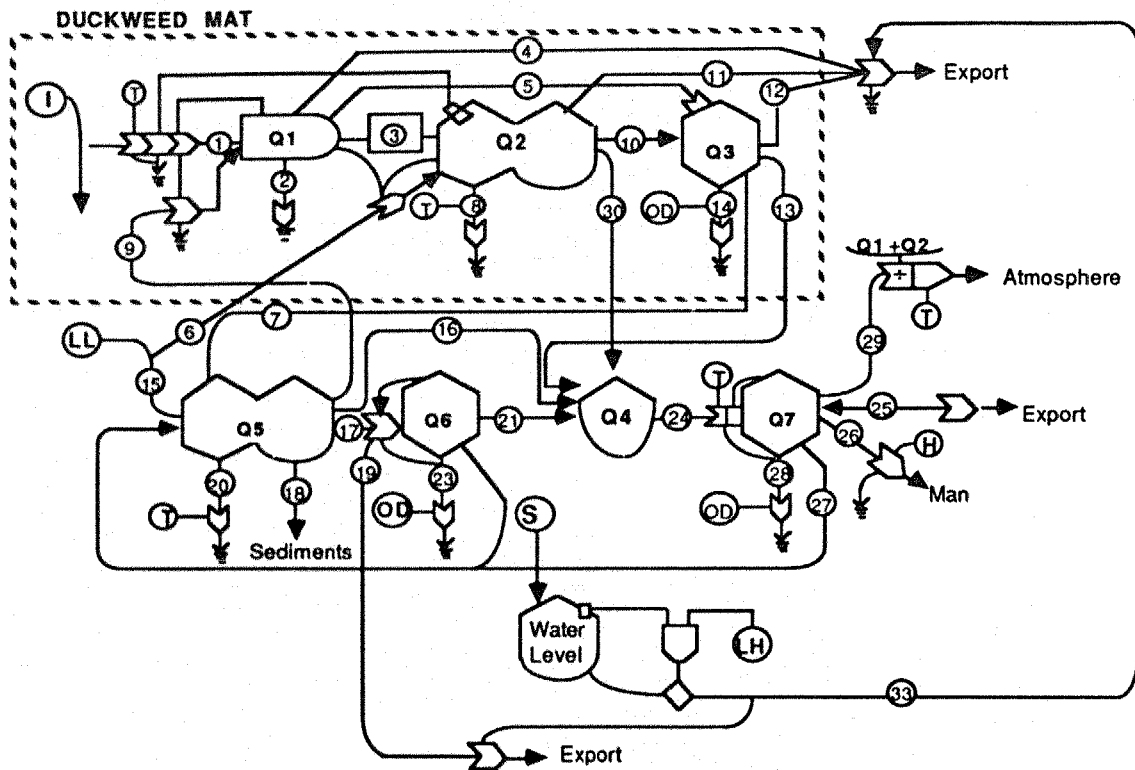


Figure 54. Simulation model for an impounded swamp (top) and simulation results for the second and third years with 1977 and 1978 forcing functions (bottom) (Sklar 1983).

predators. Water level controlled export of detritus and was a direct function of levee height. Figure 54 shows the field measured and simulated behavior of floating vegetation, floating consumers, aquatic predators, and benthic consumers. In general, the model mimics the measured behavior fairly well. Averaging over all the state variables, the model only achieved an  $R^2$  value of 0.5, mainly because it was slightly out of phase with some of the more dramatic peaks in the field data.

Lowering the levee height had dramatic effects on the model. It increased runoff, decreased detrital sedimentation, increased total animal biomass and, most importantly, increased organic matter export downstream by almost 50%.

The Sklar et al. model could be improved by incorporating the emergent vegetation component into the model, and by optimizing the model's parameters to achieve a better fit with the field data. This would allow more accurate predictions of future system behavior.

Simulation studies like the two mentioned above can do much to aid our understanding of the dynamic and often counterintuitive response of ecological systems to human or natural changes. With the accounting models mentioned earlier as basic data, simulation models provide a rational method to access the potential impacts of alternative management strategies. They provide the basis for effective long term management of ecological resources, but must be supplemented with other models that specifically take a longer, broader view.

#### 9.4 LONG-TERM MANAGEMENT MODELS

Three modeling studies are reviewed in this section: (1) Eckenrod et al. (1979) predicted the effects of urbanization on hydrologic conditions, fisheries, wetland area and other variables in the New Orleans area for 30 years into the future; (2) Hopkinson and Day (1980a) also looked at the long term effects of urban development on storm water and nutrient runoff, as a companion to their hydrodynamic model mentioned earlier for the upper Barataria Basin; and (3) Cleveland et al. (1981) simulated the long term effects of artificial canals on land loss in the lower Barataria Basin.

A diagram of the Eckenrod et al. (1979) model is shown in Figure 55. The model includes 15 state variables, 6 describing the natural sector, and the remainder describing the urban sector. The model compares the current trend, in which economic and population growth follow the present pattern for the next 30 years, to a "high intensity development" and a "steady state" condition. The summary of results shown in Figure 55 indicate the model's predictions of much higher resource use and dependence on imported food in the high intensity case, along with larger loss of wetland area and decreased fisheries. These results are to be expected, but there is no way of judging the model's accuracy since no historical data are presented. Particularly with aggregated, long-term models it is important to run the models with historical data to determine the ability of the model to duplicate the past before projecting to the future. This modeling study could be improved by incorporating historical data.

The Hopkinson and Day (1980a) model concentrates on the effects of land use changes on hydrology and nutrient runoff in the upper Barataria basin. Figure 56 shows the model results for 1995 compared with 1975 conditions for percent runoff as a function of rain input, infiltration rates, initial soil moisture, and land use characteristics. In general, percent runoff seems to increase about 10%, largely because of the increase in impervious area. Nutrient inputs to natural water bodies also increase, suggesting that eutrophication problems will intensify if current development patterns continue. As with the Eckenrod et al. (1979) study, this modeling study could benefit from the collection and incorporation of more historical data to test its degree of fit to the real system.

Cleveland et al. (1981) constructed a simulation model to investigate the impacts of canals (mainly associated with oil and gas exploration) on land loss rates in the Barataria Basin over the next 100 years (Figure 57). The model incorporates the balances between the natural processes of sedimentation, erosion, and subsidence on the one hand, and the impact of canals, both directly and indirectly, on the other. It also distinguishes between streamside and inland marsh. Results of the model shown in Figure 57 indicate the natural decline in wetland area in a senescent delta lobe like the Barataria Basin, along with the increased rate of decline caused by

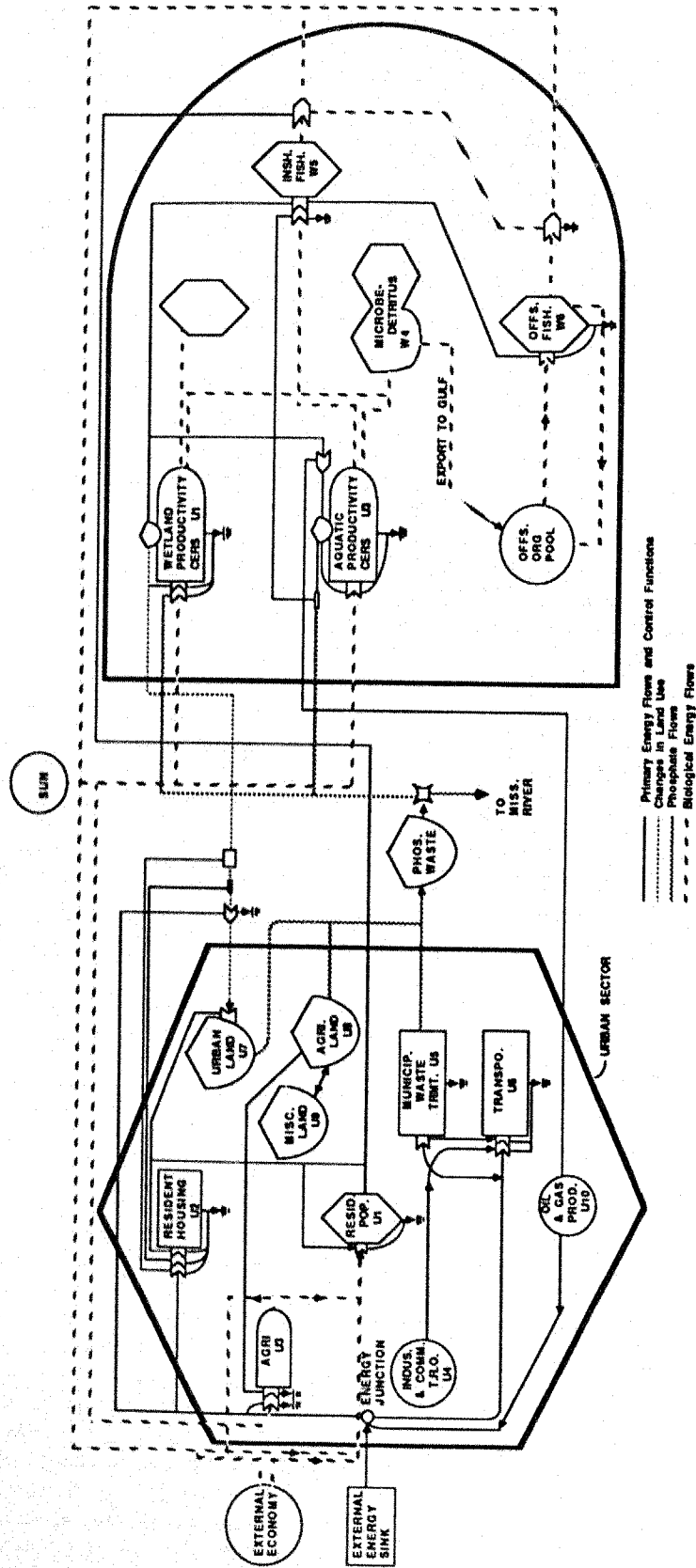
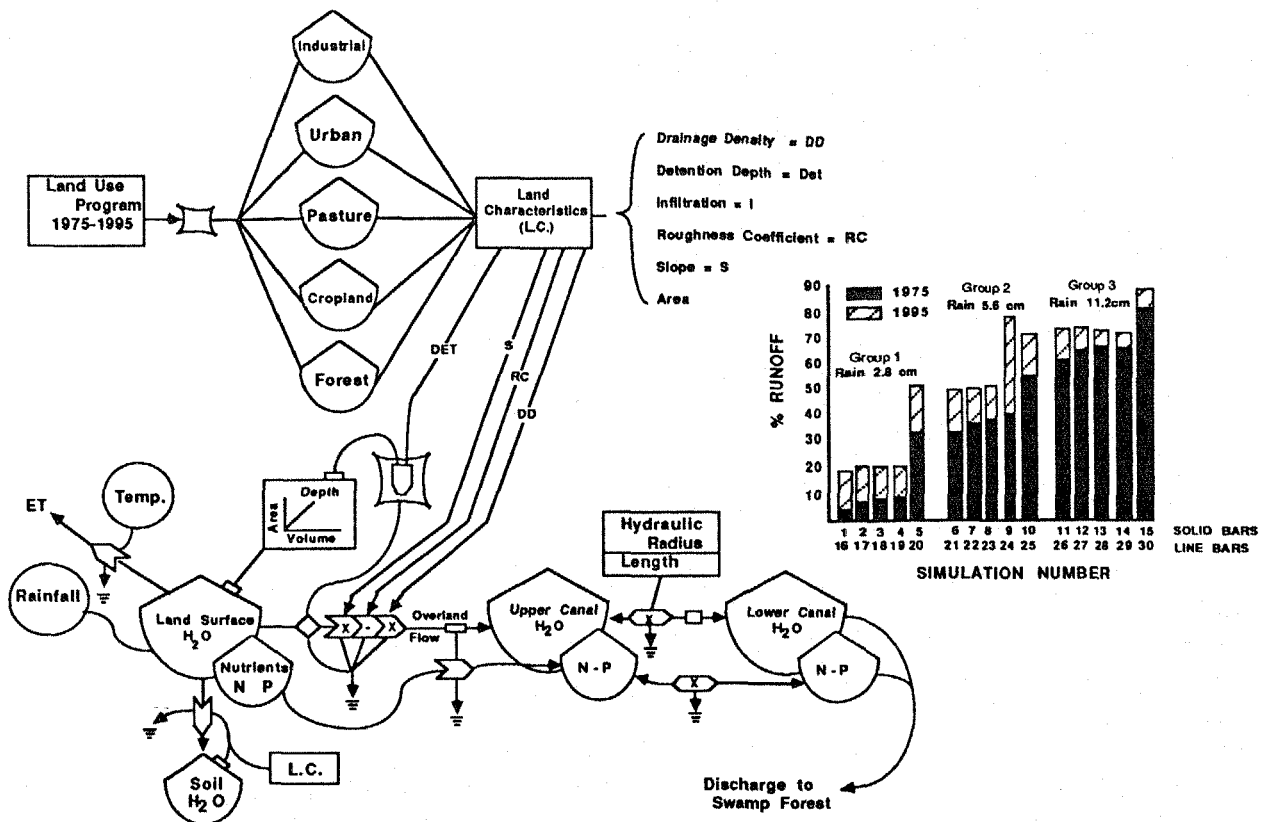


Figure 55. Energy and material flow diagram for New Orleans (reprinted, with permission, from Eckenroed et al. 1979, copyright University of South Carolina Press).



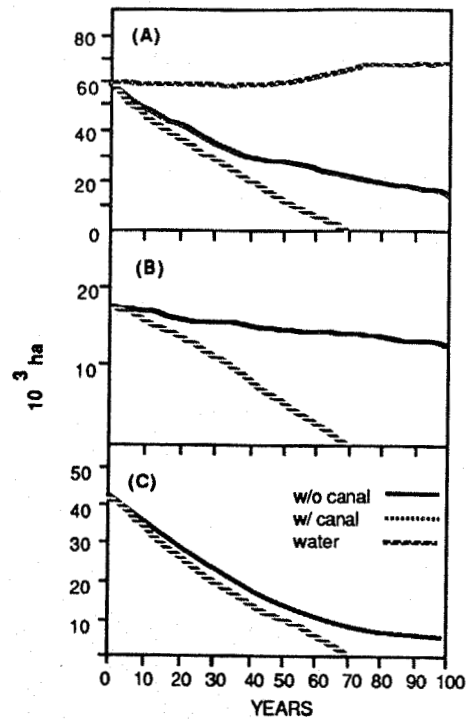
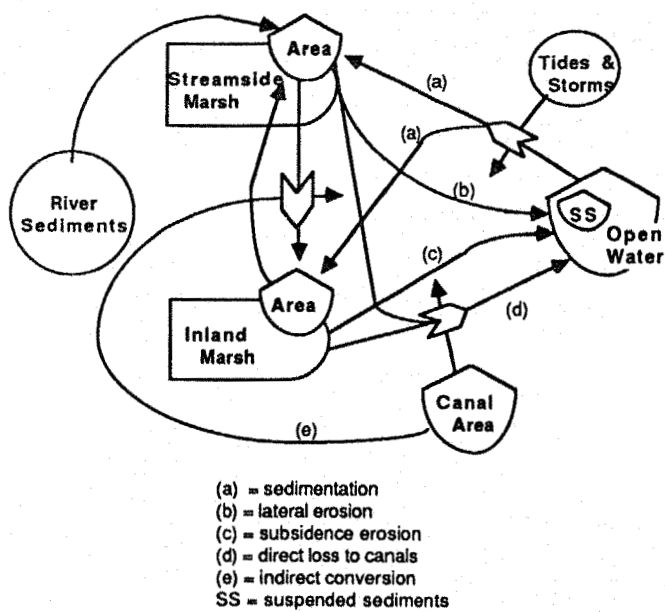
**Figure 56.** Conceptual model relating the influence of land use characteristics on storm water and nutrient runoff from upland areas to the receiving wetlands (top) and tabular comparison of the effects on storm water runoff (bottom) with present (1975) and future (1995) land use. Solid bars (1-15) represent results for 1975 land use; line bars (16-30) are for 1995. The 30 bars are aggregated in 3 groups: group 1: bars 1-5 and 16-20; group 2: bars 6-10 and 21-25; group 3: bars 11-15 and 26-30. Rainfall inputs increased from group 1 to 3: 2.8, 5.6, and 11.2 cm/storm, respectively. There is a sequence of 5 bars in each group. In each group the first bar (for example, #1 and #16 in group 1) represents conditions of maximum and minimum of infiltration rates of 4.1 and 0.5 cm/hr, respectively. The second bar has max-mins of 2.0 and 0.5; the third 1.0 and 0.5; the fourth 0.5 and 0.5; and the fifth bar in each group had max-min rates of 4.1 and 0.13 cm/hr, respectively. The sequence from 4.1 and 0.5 to 0.5 and 0.5 cm/hr represents a condition of increasing initial soil moisture content -- from a dry soil to a saturated soil (reprinted, with permission, from Hopkinson and Day 1980b, copyright Springer-Verlag).

artificial canals. It also shows that the re-introduction of riverine sediments could lead to a net gain in wetland area (Figure 57).

### 9.5 SUMMARY AND CONCLUSIONS

The modeling studies that have been completed in the Barataria Basin have helped to focus and synthesize our understanding of the hydrology and ecology of the basin, and to point out the long term implications of current trends. Models, particularly mathematical models, are

essential in this regard. In general, the models could be improved by collecting enough data to quantify the model's goodness-of-fit. This would allow broader application of the model's results with some known degree of confidence. Only a few of the models reviewed quantified goodness-of-fit. Without this data the models cannot be thought of as truly quantitative. Efforts to build better models will continue in the Barataria Basin and elsewhere in south Louisiana. They can build on the successes of their predecessors and attempt to overcome the limitations of those early models.



**Figure 57.** Conceptual model of natural and human-induced land loss (left) and the results of the simulation for total marsh area (A), streamside marsh area (B), and inland marsh area (C) (reprinted, with permission, from Cleveland et al. 1981, copyright Elsevier Scientific Publishing Co.).



## CHAPTER 10

### MANAGEMENT ISSUES

by

N. J. Craig and J. W. Day, Jr.

#### 10.1 INTRODUCTION

Barataria Basin wetlands and waters serve as wildlife habitat, vital nursery areas for fish and shellfish, water storage reservoirs, and as a source of nutrients and organic matter. These combined factors result in enormous biological productivity. The region also produces a significant portion of the nation's petroleum supply, and is an important navigational and commercial harbor. The natural resources in the basin have in recent decades attracted increasing numbers of people, commerce, and industry. The resulting human activity (Table 34) has caused the degradation of the wetland system.

The wetland-estuarine system has been used as a waste repository for domestic and industrial discharges and agricultural drainage. Exploration and development of oil and gas reserves in the wetlands have resulted in extensive channelization, spoil disposal, and serious alteration and loss of wetlands. The major categories of environmental impact within the Barataria Basin are wetland loss, eutrophication, salt water intrusion, reduction of nursery grounds for fisheries, and introduction of toxic substances into wetlands. Human activity in the Barataria Basin has had a major impact on the wetlands in the past, and these problems, as well as cumulative and synergistic environmental impacts, will intensify over time because of population and industrial expansion. Wetland loss rates throughout the United States are generally in proportion to population density and amount of industrial development. This chapter will examine the major environmental impacts within the basin and suggest management strategies.

#### 10.2 WETLAND LOSS

Wetland loss is the result of cumulative impacts, the consequence of both natural and artificial influences. Natural losses are caused by subsidence, decay of abandoned river deltas, waves, and storms. Artificial losses result from flood control practices, impoundment, dredging, and subsequent erosion of artificial channels. Wetland losses also occur from spoil disposal upon wetlands and land reclamation projects (Craig et al. 1979). Land loss has been defined "as the substantial removal of land from its ecologic role under natural conditions" (Craig et al. 1979). Impounding or filling of wetlands does not eliminate an area by converting it to water or land but is considered a loss because it removes the wetlands' natural ecological function.

Losses occur in three basic ways: (1) wetlands become open water because of natural or artificial processes -- loss of this type may be caused by erosion, subsidence, or dredging; (2) wetlands are covered by fill material and altered to terrestrial habitat; and (3) wetlands can be wholly or partly isolated by spoil banks (Craig et al. 1979).

Wetland loss in abandoned river deltas was once compensated for by land building in the region of the active delta. Today, because of human intervention, there is a net wetland loss of  $102 \text{ km}^2$  ( $39.4 \text{ mi}^2$ ) annually in coastal Louisiana (Gagliano et al. 1981) with some estimates as high as  $155 \text{ km}^2$  ( $60 \text{ mi}^2$ ) (Paul Templet, LSU Environmental Studies; pers. comm.).

**Table 34.** Selected use-issue categories and human activities in coastal Louisiana (Happ et al. 1976).

Use-Issue Category	Activities
Mineral and energy extraction	Exploration, dredging, drilling, casting and cementing, treating oil field emulsions, pipe laying, brine disposal, drilling and mud disposal, facility abandonment, and oil spills.
Navigation and transportation	Canal construction and maintenance, spill disposal, dock construction, waterweed control, boat traffic, harbor-port development and use, airport construction and use, highway construction and use, and railroad construction and use.
Flood control and hurricane protection	Levee construction (dredging, spoil disposal, and right-of-way), channel improvement (cutoff and improvement dredging, revetments, and dikes), and water control construction (spillways and pumping).
Recreation and tourism	Sportfishing, beach, river, and lake activities, camping, boating, outdoor games, hiking, hunting, and tourism.
Fishing and trapping	Harvesting (commercial and sportfishing), boat operation, and commercial processing.
Aquaculture	Levee construction, impoundments, semi-impoundments, and water control structures.
Wetlands maintenance	Weir construction, pesticide and herbicide application, mechanical tilling, marsh burning, pothole, plug, and ditch construction, cattle grazing, and impoundment construction.
Agriculture and forestry	Commercial harvesting, soil preparation, pest control, cultivation, irrigation, fertilization, land use conversion for agriculture, and various other management practices (flood and saltwater intrusion control).
Urban development	Sundry economic activities.

### 10.2.1 Natural Wetland Loss

The deltaic plain in which the Barataria Basin lies is an area of dynamic geomorphic change. For the past several thousand years, the Mississippi River has followed a pattern of extending a delta seaward into the gulf in one area,

and, after a few hundred years, abandoning it gradually in favor of a shorter adjacent route of steeper gradient (Morgan and Larimore 1957). When a delta lobe is abandoned, active land building via sedimentation ceases and net loss of land occurs due to erosion and subsidence. Because of levee construction, the Mississippi

River has been effectively "walled in," and presently most of the sediments and nutrients of the river are deposited in the deep Gulf of Mexico and are unable to contribute to the buildup or maintenance of the coastal wetlands (Craig et al. 1979).

The most important processes affected by lack of sediment input are the rates of sedimentation and net marsh accretion of both streamside and inland marshes (Cleveland et al. 1981). DeLaune et al. (1978) found that marsh sites nearer natural streams were accreting at a higher rate than inland marsh sites (1.35 cm/yr vs. 0.75 cm/yr), and only streamside marsh areas were accreting fast enough to offset the effects of subsidence. Similar patterns of accretion were noted by Baumann (1980), who observed a mean aggradation deficit of 0.18 cm/yr for 80% of the marsh in Barataria Basin. He proposed that this mechanism was responsible for a large portion of the marsh currently being lost in the Barataria Basin.

Barrier islands along the coast are a strong defense against marine processes and hurricanes. The tidal passes between the islands act as control valves for the estuaries by regulating the amount of high salinity water and storm energy that enter the estuaries (Gagliano 1973). The barrier islands of the Barataria Basin are currently eroding; Grand Isle and Grand Terre are listed as areas of "critical erosion" by State and Federal agencies. Limited coastal sand supply in Louisiana has caused one of the most serious barrier island problems in the country. Barrier island retreat rates are as high as 50 m/yr and loss rates of 65 ha (160 acres)/yr have been reported (Mendelssohn 1982).

#### 10.2.2 Human-Induced Wetland Loss

Human activities that contribute to wetland loss are flood control, canals, spoil banks, land reclamation, and highway construction. There is increasing evidence that canals are a leading factor in wetland loss (Craig et al. 1979; Cleveland et al. 1981; Deegan et al. 1983; Scaife et al. 1983). For example, in the 14-year period between 1962 and 1974, 18,138 ha of wetland in Barataria Basin were drained or converted to water, with agricultural impoundments and oil access canals accounting for the largest acreages (Adams et al. 1976).

a. Canals. Artificial canals interlace the wetlands of the Barataria Basin. Natural channels are generally not deep enough for the needs of oil recovery, navigation, pipelines, and drainage, so a vast network of canals has been built to accommodate these needs. The construction of canals leads to direct loss of marsh by dredging and spoil deposition and indirect loss by changing hydrology, sedimentation, and productivity. Canals lead to more rapid salinity intrusion causing the death of freshwater vegetation (Van Sickle et al. 1976). Canal spoil banks severely limit water exchange with wetlands, thereby decreasing deposition of suspended sediments. The ratio of canal to spoil area has been estimated to be 1 to 2.5 (Craig et al. 1979), indicating the magnitude of spoil deposition as a cause of wetland loss.

It has been estimated that between 40% and 90% of the total land loss in coastal Louisiana can be attributed to canal construction, including canal-spoil area and cumulative losses (Craig et al. 1979; Scaife et al. 1983). In the deltaic plain of Louisiana, canals and spoil banks are currently 8% of the marsh area compared to 2% in 1955; there was an increase of 14,552 ha of canals between 1955 and 1978 (Scaife et al. 1983). Barataria Basin had a 0.93%/yr direct loss of marsh due to canals for the period of 1955-78 (Scaife et al. 1983). Canals indirectly influence land loss rates by changing the hydrologic pattern of a marsh, such as blockage of sheet flow, which in turn lessens marsh productivity, quality, and the rate of accretion. Canals widen with time because of wave action and altered hydrologic patterns, and apparently the larger the canal, the faster it widens. Annual increases in canal width of 2% to 14% in Barataria Basin have been documented, indicating doubling rates of 5 to 60 years (Craig et al. 1979).

Generally, where canal density is high, land losses are high and where land losses are low, canal densities are low. The direct impacts of canals are readily measurable. For example, from 1955 to 1978, canal surface area accounted for 10% of direct land loss. The indirect influence of canals extends far beyond this direct loss. Craig et al. (1979) estimated the total direct and indirect loss of wetland caused by canals is 3-4 times the initial canal area alone. Although total canal surface area alone may not be a dominant factor in wetland loss, direct and indirect impacts of canals may account for some 65% or more of the total

wetlands loss between 1975 and 1978 (Scaife et al. 1983).

b. Cumulative impact of canals. The current trend of continued habitat loss will inevitably lead to severe wetland degradation. Each permitted oil access canal or dredge and fill activity may seem small and unimportant on a case-by-case basis, each appearing as an insignificant localized impact. However, when the cumulative impacts are considered, the effects are greatly magnified. The canals, when viewed on a regional basinwide level, become a network ultimately resulting in higher rates of wetland loss (Craig et al. 1979), increased saltwater intrusion (Van Sickle et al. 1976), changes in the hydrology of the wetland system (Hopkinson and Day 1979; 1980a, 1980b), a reduction in the capacity for wetlands to buffer impacts of large additions of nutrients resulting in eutrophication (Craig and Day 1977; Hopkinson and Day 1979, 1980a, 1980b; Kemp and Day 1981), a loss in storm buffering capacity, and a loss of important fishery nursery grounds (Turner 1977; Lindall et al. 1979; Wagner 1970; Chambers 1980).

Since canals are an important factor affecting land loss, a measure of the impact of canals is potential fisheries loss. An estimated \$8-\$17 million of fisheries products and services are annually lost in Louisiana because of wetland destruction (Craig et al. 1979). Commercial fish yields have been shown to be related to the area of coastal wetlands (Turner 1977, 1979, 1982). Therefore any wetland loss caused by canals is detrimental to fisheries.

### 10.2.3 Management Strategies for Land Loss

a. Canal regulation. A management philosophy of zero-habitat loss looks beyond simply minimizing the impacts of loss. Mitigation schemes to compensate for the unavoidable adverse impacts associated with human activities are necessary. But mitigation options which seek to achieve zero-habitat loss can best be achieved with the preservation, restoration, and creation of wetlands. Any activity with adverse impacts on the wetland systems, such as canalization, should be permitted only if it is mitigated by creation, restoration, or enhancement of wetland areas. Natural biological productivity, wildlife habitats, species diversity, water quality, and other unique features of wetlands should be maintained

(Coenan and Cortright 1979). Management decisions should be made with long-range, hydrological, basinwide considerations, and should reinforce the natural function of the wetlands.

Canals are obviously an important agent in wetland alteration, affecting not only marsh loss, but salinity intrusion and eutrophication as well. Canalization should be permitted only where there is absolutely no other alternative and then with the mitigation clause of "no net wetland loss." There are other management techniques designed to reduce the direct impact of the canal if it is, indeed, permitted. The least damaging construction technology available should be employed in all cases (Table 35). Several alternatives are available, including directional drilling, that would reduce the number of canals needed for oil and gas exploration. Hydro-air cushion vehicles would eliminate the need for canals entirely. Hydro-air cushion drilling systems are currently economically competitive with traditional drilling rigs on barges (Table 36).

b. Creative use of spoil. Approximately 80% to 90% of the dredging that takes place within the continental United States occurs in Louisiana (Lindall and Saloman 1977). An enormous amount of spoil is generated every year, and spoil disposal on wetlands is the general rule. It has been reported that for every mile of pipeline installed by flotation canal, 30-36 acres of marsh are altered as a result of spoil deposition (McGinnis et al. 1972).

In order to reverse this trend in wetland alteration, spoil should be viewed as a reusable resource rather than as waste. It is possible to use these sediments productively to create and aid in the management of habitat. A 5-year (1973-78) Dredged Material Research Program (DMRP) was conducted by the Corps of Engineers at the Waterways Experiment Station in Vicksburg, Mississippi, based on this idea. Spoil can be used as a substrate for wildlife habitat (e.g., islands for nesting birds), marsh habitat, beach renewal, restoration of bare ground, construction material, and sanitary landfill. Wetland substrates which are subject to subsidence or erosion can benefit from a deposit of dredged material to replenish what has been lost (National Marine Fisheries Service 1979; Hunt 1979). Major experimental field tests (Table 37) have tested vegetation establishment techniques and principles for spoil use. These

**Table 35. Recommendations to minimize the impact of canals.**

Recommendation	References
Minimize new canal construction by required multiple use of existing canals and common use of pipeline canals.	Craig and Day 1981
Restrict new canals to natural corridors, levees, or defined development corridors.	Gagliano 1973
No construction of canals which connect (a) fresh and saline areas, or (b) the edge and center of hydrologic basins.	Craig and Day 1981; Gosselink et al. 1979
No construction of blind-end canals or fingerfill developments.	Craig and Day 1981
Canal depths should not exceed that of the euphotic zone (1.8-2.0 m at mean low water) except where normal turbidity results in shallow euphotic zone.	Craig and Day 1981
Canal depths should never exceed the depth of the water body where the canal terminates.	Craig and Day 1981
Canals should be of uniform depth or become gradually shallower proceeding inland from a central water body to insure adequate flushing. This prevents formation of stagnant pockets of water.	Craig and Day 1981
Alignment of canals should take advantage of existing natural channels or existing artificial channels.	Craig and Day 1981; Longley et al. 1978
Limit canals between vegetative types.	Stone and McHugh 1979
Perform dredging operations as quickly as possible.	Gosselink et al. 1979; Darnell 1977
Dispose of soil with special care; place in nonwetland areas of use in marsh creation.	Craig and Day 1981; Lindall et al. 1979
Place periodic opening in existing spoil banks to prevent impediment of water circulation.	Craig and Day 1981; Longley et al. 1978; Lindall et al. 1979
Place water control structure on all existing waterways.	St. Amant 1971, 1972
Plug pipeline canals on seaward side until construction is finished and backfilling completed.	St. Amant 1971, 1972
Dredging and construction should be done to minimize turbidity and scheduled to avoid time of wildlife migrations, spawning, and nesting.	Gosselink et al. 1979; Bahr and Hebrard 1976
Backfill and refurbish canals.	Happ et al. 1976; Lindall et al. 1979
Avoid constructing canals which shunt nutrients from urban areas directly into water bodies.	Craig and Day 1981; Gael and Hopkinson 1979; Seaton and Day 1979; Hopkinson and Day 1979
Environmentally sensitive areas should be avoided. Examples: oyster reefs, rookeries, submerged grassbeds.	Lindall et al. 1979

**Table 36.** Comparison of conventional swamp barge to marshland air cushion drilling system (MACDS).

Process	Swamp barge	MACDS
Permit processing	Time required	Nil
Route surveys	Major	Minor
Directional drilling required	Yes	No
Support equipment	Yes	Yes
Drill depth capability	20,000'	25,000'
Time to mobilize to new site	High	Low
Major rig equipment	Old	New
Mobility	Poor	Good
Capital equipment cost	Moderate	Higher
Channel dredging required	Yes	None

studies demonstrated that dredged material can be disposed of in a biologically productive manner and that the engineering characteristics and behavior of dredged and disposed sediments can be predicted and determined.

c. Barrier island stabilization. Barrier island stabilization has been used to retard land loss of both islands and the wetlands they protect from storm wave activity. Structural and biological approaches have been considered. The structural approach involves construction of groins and riprap, which may stabilize one area at the expense of another. Beach nourishment (pumping sand onto the beach from offshore) is another technique that has been used, especially along the south Atlantic coast. The biological approach generally involves planting grass to stabilize dunes. This method appears to be successful, at least in the short-term (Mendelssohn 1982).

d. Controlled diversions. Flood control measures such as leveeing along the Mississippi River have interrupted the balance between riverine and marine processes which result in sediment transport, deposition, and introduction of valuable freshwater and nutrients. These processes, which built and stabilized the marsh and swamp areas via overbank flooding, are now virtually eliminated in coastal Louisiana.

**Table 37.** Characterization of habitat development field sites (from Hunt 1979).

Site name	Location	Type of habitat development	Substrate	Salinity
Miller Sands	Lower Columbia River, Astoria, Oregon	Marsh and upland	Sand	Fresh
Salt Pond 3	South San Francisco	Marsh	Clay	Saline
Bolivar Peninsula	Galveston Bay, Texas	Marsh and upland	Sand	Saline
Drake; Wilson Island	Apalachicola Bay, Florida	Marsh	Silt fill sand dike	Saline to brackish
Buttermilk Sound	Atlantic Intracoastal Waterway, Brunswick, Georgia	Marsh	Sand	Fresh to brackish
Windmill Point	James River Chester, Virginia	Marsh	Silt fill and sand dike	Fresh
Nott Island	Connecticut River Essex, Connecticut	Upland	Sand and silty sand	Fresh with salt wedge

Schemes for controlled diversions of the Mississippi River have been developed as a means of introducing river water and sediment into wetlands to offset wetland loss. "Basically, this approach would re-establish the overbank flow regime of the Deltaic plain, presently disrupted by flood protection levees, and restore more favorable water quality conditions to the highly productive deltaic estuaries" (Gagliano et al. 1981). The feasibility of controlled diversion is indicated by the relatively small input of energy and materials needed to build a major subdelta (Gagliano et al. 1971). The U.S. Army Corps of Engineers (1984) has suggested a number of potential sites for controlled diversions into the Barataria Basin (see Figure 58).

A major drawback of these schemes is the toxic contamination (heavy metals, pesticides, synthetic organic chemicals) of both water and

sediment from the Mississippi River (Friloux 1971; Brodtmann 1976; Wells 1980; U.S. Army Corps of Engineers 1980). Careful assessment of this problem should precede any actual diversion that does occur, and careful monitoring for toxic substances should be an integral part of a controlled diversion plan.

e. Controlled diversion vs. regulation of canals. Comparison of the effect of different management options and mitigation techniques for reducing wetland loss in Louisiana (Table 38) has revealed that regulatory control of new canals could reduce loss rate about 13-36 km<sup>2</sup>/yr, in contrast to 1-3 km<sup>2</sup>/yr reduction from controlled diversion schemes (Day and Craig 1982). In other words, if canal construction continues at its present rate the land loss rate would be 13-36 km<sup>2</sup>/yr greater than if no new canals were permitted.

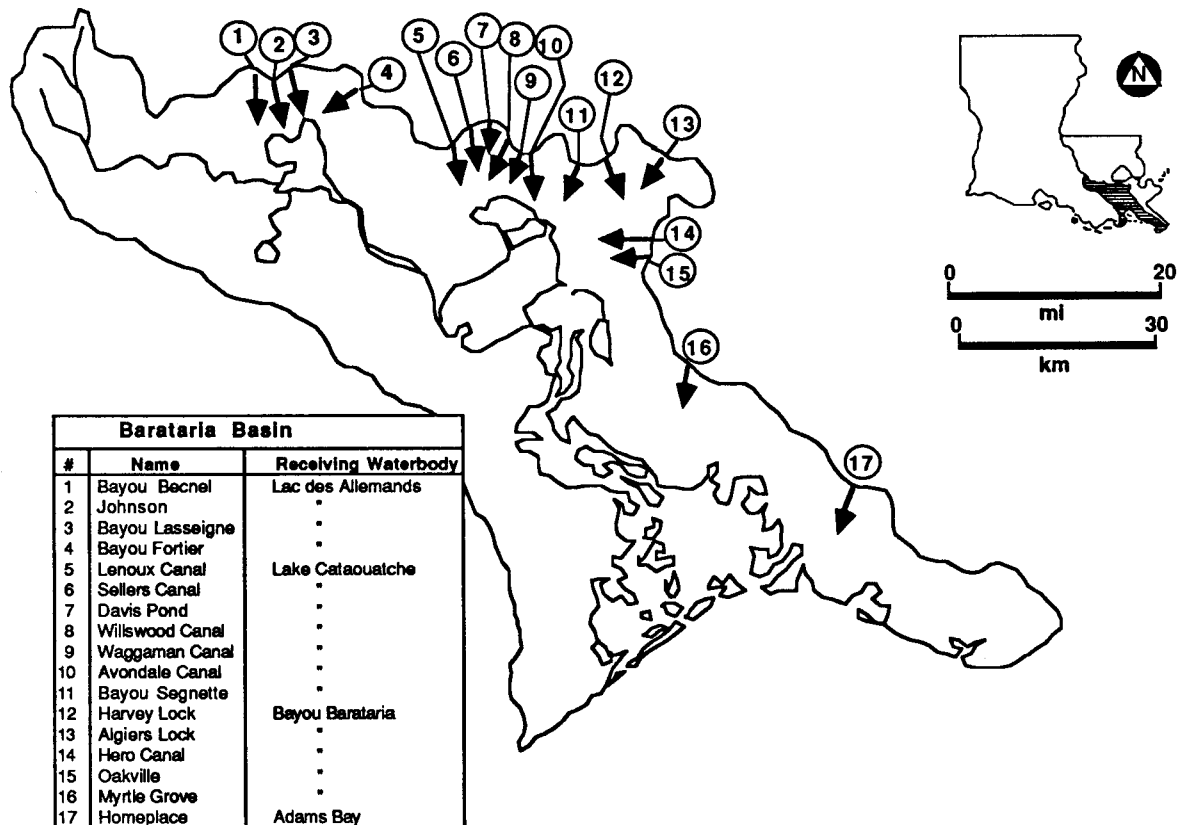


Figure 58. Location of the potential freshwater diversion sites in Barataria Basin (after U.S. Army Corps of Engineers 1984).

**Table 38.** Effect of several different mitigation techniques for reducing wetland loss (modified from Day and Craig 1982).

Activity	Reduction in wetland loss rate (km <sup>2</sup> /yr)
Atchafalaya River -- new delta growth	11.9
Reversal of Chenier Plain beach retreat <sup>a</sup>	1.1
Infilling of older marshes	4.9
Total	17.9
Controlled Diversions Lower Mississippi River <sup>b</sup>	1-3
Prohibition or strict regulation of new canals <sup>c</sup>	13-36

<sup>a</sup> This value assumes the present net rate of shoreline retreat will be arrested. The net rate of retreat was calculated as the algebraic sum of shoreline changes for each interval along the Chenier Plain as given in Adams et al. (1978).  
<sup>b</sup> Gagliano et al. (1981), assuming present diversions.  
<sup>c</sup> High estimate from Turner et al. (1982), low estimate from Deegan et al. (1983).

Controlled diversions of the Mississippi River have the potential to impact areas with high wetland loss rates, possibly improving fisheries, but they require advance planning and operational experience. On the other hand controlled diversions are area-specific and can only affect the lower Mississippi River. They also have high engineering costs and can introduce toxic substances from the Mississippi River into the wetlands.

Regulatory control over canals has the advantage of affecting all areas of the coastal zone and addressing the major cause of wetland loss. The disadvantages are that the political and private sectors oppose such strict regulation and that we lack complete information on the relationship of canals and wetland loss. "Any management plan that is to successfully combat coastal erosion on a meaningful level must address canal impacts and management" (Turner et al. 1982).

### 10.3 MANAGING EUTROPHICATION

Eutrophication is the natural or artificial addition of nutrients to water bodies and the effects of these added nutrients (Rohlich 1969). Eutrophication is a natural process which has been greatly accelerated by human activity.

Most of the waters of the middle and upper basin, including Lake Cataouatche and Lac des Allemands, are eutrophic. The eutrophic waters are characterized by frequent algal blooms, dominance by fish like gar and shad, and fish kills caused by low levels of dissolved oxygen. Domestic wastes are an increasing nutrient problem because of inadequate sewage treatment and population growth. Urban runoff is a significant pollution source from cities. Paved areas increase surface runoff into storm sewers that shunt nutrients, as well as toxic materials, into water bodies. Fertilizers, animal manure, and large quantities of nutrients from eroded sediments enter lakes via drainage canals. Wastes from industrial sites are also often sources of nutrients. Natural sources of nutrients are precipitation, excrement from waterfowl and wading birds, and organic mineralization (Bahr et al. 1983). The major sources of nutrients causing eutrophication in the Barataria Basin are agricultural and urban nonpoint source runoff (Day et al. 1977; Craig and Day 1977; Seaton and Day 1979; Hopkinson and Day 1980a).

Witzig and Day (1983a) developed a Trophic State Index (TSI) to classify the water bodies in Barataria Basin using existing water quality data (see Table 4, Chapter 3). Positive TSI scores are indicative of high nutrient enrichment and negative scores of low nutrient enrichment. The water bodies range from hypereutrophic to meso-oligotrophic. The current phosphorus loading rate for Lac des Allemands is 4.3 g/m<sup>2</sup>/yr; for Lake Salvador, 0.97 g/m<sup>2</sup>/yr; and for Lake Cataouatche, 1.6 g/m<sup>2</sup>/yr (see Tables 39 and 40 for critical and permissible loading rates). The most eutrophic waters are those directly affected by upland runoff.

The majority of the runoff from agricultural and urban areas is channelized and flows directly into neighboring waterbodies, short-circuiting flow through local wetlands. Under natural conditions, runoff from the natural levee



**Table 39.** Permissible loading levels for total nitrogen and total phosphorus (biochemically active)  $\text{g/m}^2/\text{yr}$  (Vollenweider 1968). The average depth of Barataria Bay is 1.5 to 2.0 m.

Mean depth of water body (up to)	Loading			
	Permissible (up to)		Dangerous (in excess of)	
	N	P	N	P
5 m	1.0	0.07	2.0	0.13
10 m	1.5	0.10	3.0	0.20
50 m	4.0	0.25	8.0	0.50
100 m	6.0	0.40	12.0	0.80
150 m	7.5	0.50	15.0	1.00
200 m	9.0	0.60	18.0	1.20

**Table 40.** Critical concentrations and critical loading rates for nitrogen and phosphorus calculated by different authors.

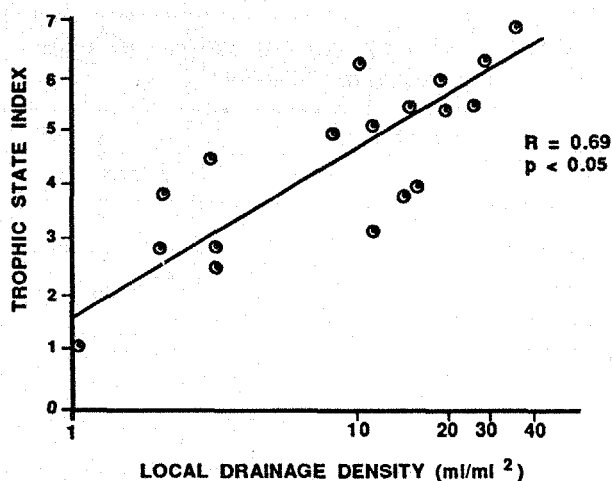
Reference	Rate	Loading			
		Permissible (up to)		Dangerous (in excess of)	
		N	P	N	P
Shannon & Brezonik (1972)	Volumetric ( $\text{g/m}^3/\text{yr}$ )	0.86	0.12	1.51	0.22
Ibid	Areal ( $\text{g/m}^2/\text{yr}$ )	2.0	0.28	3.4	0.49
Vollenweider (1968) for lakes <5 m.	Areal ( $\text{g/m}^2/\text{yr}$ )	1.0	0.07	2.0	0.13

flows as a diffuse sheet into adjacent wetlands and travels slowly through these wetlands before discharging into waterbodies.

A number of significant chemical, physical, and biological differences occur during the sheet flow of water through a wetland as opposed to channelized flow. Wetlands modify and buffer the effects of storms and flooding by providing storage for large amounts of water. This water is discharged as runoff from the wetland evenly and over a long period of time. Channelized runoff enters waterbodies as a pulse shortly after rainfall. The chemical composition of channelized flow is distinctly different from water flowing from the swamps. Upland runoff contains eroded sediment, fertilizer nutrients, pesticides, and other compounds washed from land surfaces. Wetlands

remove suspended sediment and associated nutrients, such as nitrogen and phosphorus.

Due to the extensive network of canals, the majority of upland runoff in the Barataria Basin is in channelized flow. Gael and Hopkinson (1979) found a positive correlation between the trophic state index and drainage density of waterbodies in the central and upper Barataria Basin (Figure 59). Drainage density, the total length of all orders of drainage network per unit area of drainage basin, reflects the degree of land development, either urban or agricultural. Gael and Hopkinson (1979) state that high drainage density moves water rapidly and directly from high nutrient loading areas, such as agricultural land, to waterbodies, effectively preventing overland flow through wetlands. In their study, a higher trophic state



**Figure 59.** Local drainage density versus trophic state index in Barataria Basin (reprinted, with permission, from Gael and Hopkins 1979, copyright LSU Division of Continuing Education).

index (greater eutrophication) resulted from an increase in drainage density.

Eutrophication can be reduced by limiting nutrient supply to the water bodies. In Barataria Basin, this would require reducing both point sources and nonpoint sources of nutrients. All domestic and industrial effluent should receive at least secondary treatment. Management practices for agriculture that have been designed to reduce runoff include mulching, grassed waterways, minimum or no-tillage, integrated pest management, and limited use of fertilizers.

Urban runoff can be controlled if the availability of pollutants to storm flows is reduced by reducing air pollution, avoiding overapplication of fertilizers and pesticides, improving street sweeping, periodically flushing collection systems, separating sewers and storm drains, minimizing exposed land area at construction sites, and maintaining vegetative cover in erodible areas (EPA 1977).

Other means of controlling urban runoff directly alter the storm water path, flow rates, or loadings. Temporarily storing storm water in storage basins or ponds, and using porous pavement can help decrease the amount of runoff entering a water body per storm. Treating of urban runoff with standard sanitary and industrial

wastewater treatment can also lessen the impact of storm water (EPA 1977).

A partial return to an overland flow regime would alleviate many environmental problems, especially in mid- and upper-basin areas. The plan would involve diverting upland runoff from channels to overland flow by redirecting existing drainage canals into wetland areas. This would be inexpensive, would not affect upland drainage systems, and could be accomplished in steps. It would, however, require the dedication of large wetland areas as "flood control areas."

An indication that such a system can work in a mutually beneficial way, at least on a small scale, can be found in a number of crayfish ponds in the swamp habitat of Barataria Basin. These ponds are all impounded areas that are actively pumped to prevent stagnation. They are flooded from September until the end of the fishing season (May or June) and then pumped dry. During the flooding period, water is circulated through the ponds on a regular schedule to maintain high oxygen levels. This seasonal pattern of summer drying and winter flooding closely approximates the natural hydrological cycle of the swamp. Studies have shown that these ponds maintain high water quality and swamp productivity (Conner et al. 1981; Kemp and Day 1981). The benefits of this system include improved water quality, increased swamp productivity, increased timber production, improved wildlife habitat value, increased crayfish production, and reduced flooding.

#### 10.4 MANAGEMENT OPTIONS FOR SALT WATER INTRUSION

Salt water intrusion is a major problem in the Barataria Basin, and results in the death of wetland vegetation, especially freshwater types (Craig and Day 1977), thereby increasing the rate of wetland loss (Craig et al. 1979).

Salt water intrusion occurs naturally in coastal basins during the abandonment stage of the deltaic cycle. However, in the Barataria Basin, human activity has accelerated the rate of salt water intrusion. The most important causal factor in this increased rate is the construction of canals, which facilitate enhanced water exchange between fresh and salt water areas. Major navigation canals which go from the coast to fresh inland areas are the

principal contributors, but any canal which makes a new hydrologic connection adds to the problem. Some examples of these kinds of canals follow (Figure 60):

1. Barataria Basin Waterway (BBW). This important navigation canal directly connects the Gulf of Mexico with the Gulf Intracoastal Waterway (GIWW). It bypasses practically all natural water connections. There are reports that the BBW has significantly altered water flow in the basin (Seaton 1979; Hopkinson and Day 1979).
2. Turtle Island Cutoff. This canal created a more direct connection between Bayou Rigolette and Little Lake, allowing more direct movement of water.
3. Bayou Signette Waterway. This canal makes a direct connection between Bayou Barataria and Lake Cataouatche, bypassing Lake Salvador.
4. In the southwestern part of the basin, a series of petroleum and navigation canals have resulted in a new connection between western Caminada Bay and Little Lake. The Bayou L'Ourse ridge, which once completely prevented such exchange, has been breached.

These impacts have been demonstrated in the Barataria Basin (Van Sickle et al. 1976; Craig and Day 1977; Hopkinson and Day 1979). Van Sickle et al. (1976) reported an average rate of salinity increase of 0.009 ppt/mo (1947-75) at St. Mary's point. Little Lake, for example, a fresh waterbody early in this century, today has a mean salinity of about 8 ppt. This change has brought about an inland shift of brackish and saline marshes (O'Neil 1949; Chabreck 1972; Chabreck and Linscombe 1978) and is coincident with an increase in wetland loss and shrinkage of viable nursery grounds (Craig et al. 1979).

Because of the detrimental effects of salt water intrusion, a number of management options have been suggested or implemented:

1. Impoundment or semi-impoundment. A number of landowners and management agencies have argued for or implemented this strategy to combat salt water intrusion. Low levees are constructed in marshes close to the waters edge to limit water exchange. Some have suggested that dredged spoil material be used for this purpose. The purpose of this

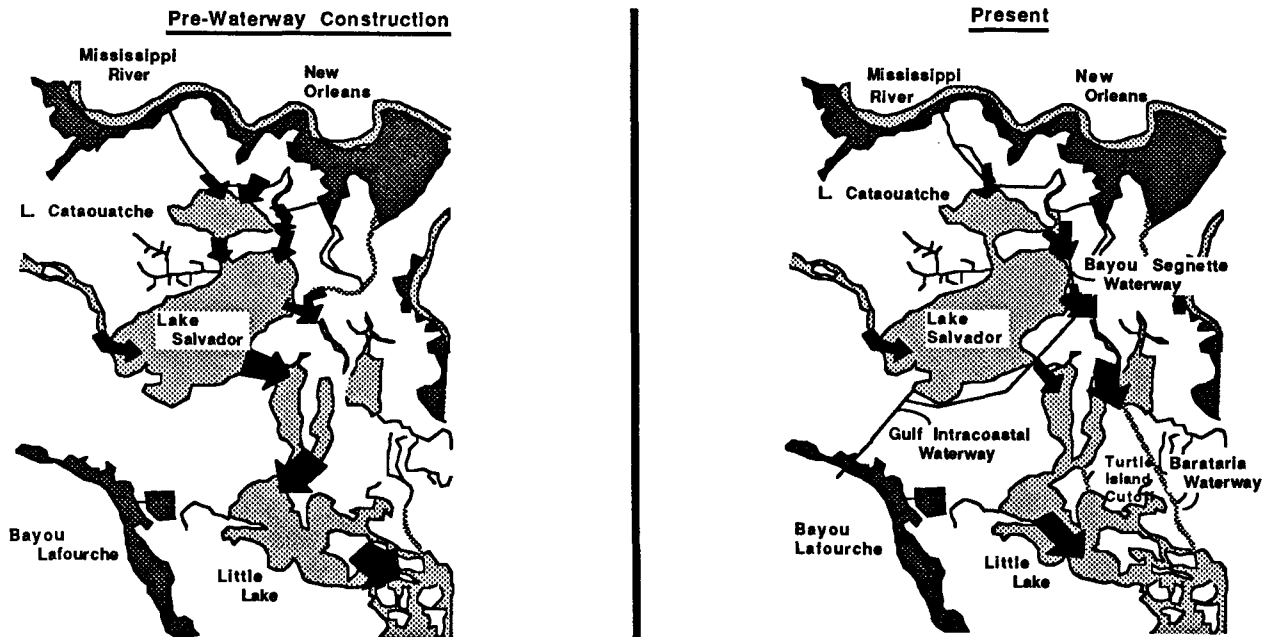


Figure 60. Past and present patterns of water movement in the central Barataria Basin (reprinted, with permission, from Hopkinson and Day 1979, copyright Plenum Press).

approach normally is to limit the flows of saline waters over lower salinity marshes.

This approach seems to be beneficial in the short-term although quantitative studies are needed to verify this. However, this strategy may lead to lower marsh productivity and to more rapid deterioration and loss of wetlands in the longer term. During periods of strong winds, bottom sediments are mixed into the water column. If this water then floods over the marsh, the majority of the suspended sediments are redeposited on the marsh surface (Baumann 1980). DeLaune and Patrick (1980) showed that the nutrients associated with the sediment deposition are the single largest source of "new" nutrients to the salt marsh and to a large degree are responsible for high marsh productivity.

These sediments are also extremely important in building up the marsh surface and thus balancing the effects of regional subsidence. Several studies in the Barataria Basin have shown that sedimentation on the streamside marsh is sufficient to maintain marsh elevation against subsidence. Sedimentation on inland marshes is not sufficient, and many inland marshes are slowly turning into open water (DeLaune et al. 1978; Baumann 1980; Hatton et al. 1983).

A number of studies have also shown that hurricanes impact semi-impounded marshes to a much greater degree than natural marshes because saline water drains much more slowly after passage of a hurricane (Ensminger and Nichols 1957; Shiflet 1963; Alexander 1967).

The above studies indicate that the practice of combating salt water intrusion by limiting marsh flooding may have negative impacts. It could result in lower marsh productivity, higher deterioration and land loss, and greater susceptibility to hurricanes. There are presently a number of ongoing investigations which may help in addressing some of these questions.

2. Increased freshwater input. Because of the levees along the Mississippi River, much less freshwater enters the Barataria Basin than in the past. One way to combat salt water intrusion is to divert more freshwater into the basins. The U.S. Corps of Engineers (1984) has identified a number of sites for possible freshwater diversion into the Barataria Basin (Figure 58). Davis Pond, northwest of Lake

Cataouatche, has been selected for intensive study and active consideration.

3. Restoration of natural hydrology. Since it has been demonstrated that canals have increased the rate of salt water intrusion, a restoration of as much natural hydrology as possible would help alleviate the problem. A number of approaches could be used here. Some canals could be permanently closed, and the cross-sectional area of other canals could be lessened structurally. Locks should be considered for major navigation channels. Before any action is taken, information is needed on the hydrodynamics and use of different canals and on the economic costs-benefits of various alternatives.

## 10.5 LOSS OF NURSERY GROUNDS

Wetlands are noted as important nursery grounds for commercial and sport fishery species. When swamps are located near coastal areas, marine species use these wetlands for nursery areas. Chambers (1980) found blue crabs, gulf menhaden, Atlantic croaker, and bay anchovy juveniles in the swamps of the Barataria Basin during winter and spring months. Estuarine fish species use the saline, brackish, and fresh marshes of the basin for their larval and juvenile growth (Wagner 1973; Kirby and Gosselink 1976; Simoneaux 1979; Smith 1979; Turner 1979). The distribution of many nursery ground species is influenced by their minimum salinity tolerance which often decreases as the fish grows. The overlap of the different nursery grounds of various species defines a general range of the nursery zone of the Barataria Basin--a broad zone from Barataria Bay to the swamp forest above Lake Salvador, which includes the most important nurseries.

### 10.5.1 Nursery Grounds: Past, Present, and Future

The coupling of salinity intrusion (increased range of oyster conch) and eutrophication (lowered water quality) within the basin has effectively reduced the region of healthy nursery grounds for oysters. Craig and Day (1977) estimated the extent of the past, present, and future nursery zone in the Barataria Basin. The data on past, present, and estimated future phosphorus loading rates and salinity levels which delineate the boundary of the nursery zone are

summarized in Figure 61 (Craig and Day 1977). For the years 1898-1910, there were no eutrophic conditions within the basin, and high salinity was limited to southern Barataria Bay (Figure 61). This past situation is indicative of a healthy nursery zone.

In the late 60's and early 70's eutrophication began to affect the upper nursery zone. Although no strict upper limit of the nursery zone can be delineated, Jaworski's citing of the decline of annual crab landings in Lake Salvador due to eutrophication corroborates the decline of the nursery zone shown in Figure 61 (Craig and Day

1977). By the year 2000, if present trends continue, water quality will deteriorate over a large area of the estuarine nursery in the Barataria Basin (Figure 61).

The projection of eutrophication increases into the future (for the year 2000) shows the extreme importance of proper planning for any future development. Development in the mid-basin could greatly increase eutrophication in Lake Salvador, further stressing nursery grounds there. Lake Salvador may be capable of absorbing the increased phosphorus loading associated with development, but the upper limit of phosphorus retention is not known. Below Lake Salvador, a bottleneck exists in Bayous Perot and Rigolettes.

Saltwater intrusion has resulted in an expansion of oyster leases in Little Lake. Accompanying the saltwater intrusion are conchs (oyster drills) and other predators that limit the oysters' gulfward range of production. Development of the buffer zone of Lake Salvador will create eutrophic conditions in Little Lake and cause the area of healthy oyster grounds to be degraded or destroyed. This eutrophic situation coupled with rising salinity could sharply limit the entire nursery zone, seriously affecting commercial fisheries for other species such as crabs, shrimp, and fish (Craig and Day 1977).

#### 10.5.2 Management for Protection of the Nursery Zone

Management issues discussed for the reduction of eutrophication and salinity intrusion within the basin are relevant to the protection of the present nursery grounds. The management techniques described for wetland loss, such as controlled diversion schemes and reduction of canals, would additionally enhance the nursery zone. The State of Louisiana has a task force of representatives from the oyster industry, the Louisiana Department of Wildlife and Fisheries, and the Health Department, that is developing a management strategy to address the issue of urban pollution inputs. A model will be used to predict the fate of upland runoff.

#### 10.6 TOXIC SUBSTANCES

The introduction of toxic materials (pesticides, herbicides, heavy metals, and polychlorinated biphenyls (PCB's), among others)

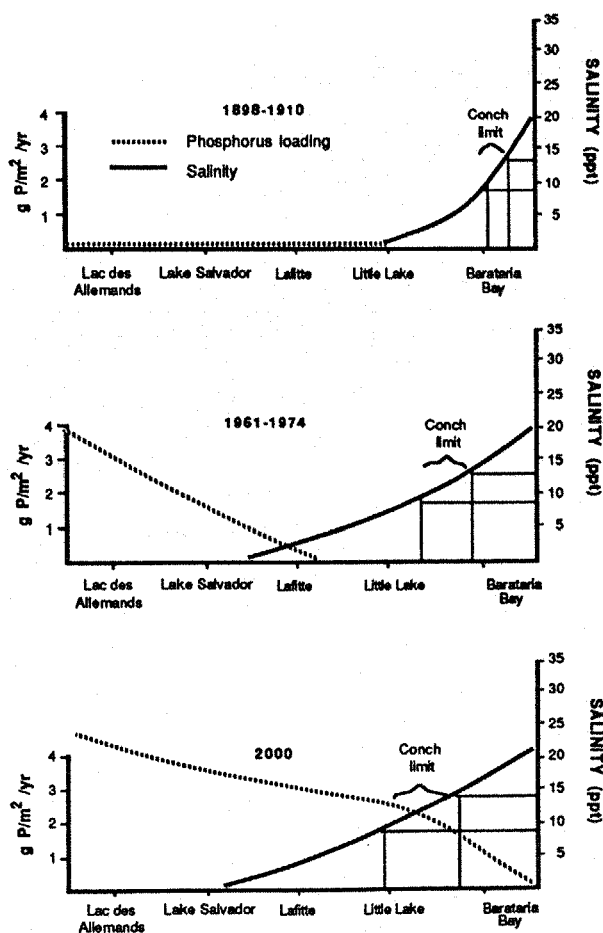


Figure 61. Estimated phosphorus loading rate and salinity levels at various locations in Barataria Basin through time. Conch range illustrates the southern limit of oyster production (Craig and Day 1977).

into wetland areas has become an increasingly serious problem nationwide. In Barataria Basin, the possibility of the introduction of toxic pollution into wetlands is great because of its proximity to one of the largest concentrations of petrochemical industries in the world (between Baton Rouge and New Orleans), large urban centers, and agricultural areas.

Barataria Basin wetlands have potential toxic input from industrial plants, domestic waste, hazardous waste sites and illegal dumping grounds, pesticides from agricultural runoff, pesticides and heavy metals from urban runoff, petroleum hydrocarbons from oil exploration and production, and the spraying of herbicides for aquatic weed control.

The petrochemical industries in Barataria Basin produce a variety of products such as vinyl chloride, nitric acid, hydrochloric acid, methylethyl ketone, styrene, sulfuric acid, acrylonitrile, benzene, and a variety of herbicides and pesticides (Mumphrey et al. 1978). Most manufactured products have waste material as a by-product. In the past, chemical wastes were often disposed of in the cheapest manner possible, without regard for the environment. In many cases, the wastes have leaked out into surrounding areas (Dow and Garcia 1980).

Although data on toxic materials in the Barataria Basin is scant, that which exists points to problems possibly caused by hazardous waste dumping. For example, in a recent study done by the EPA, Barataria Bay was characterized as having chronic contamination by PCB's. The source of the contamination was unknown (Cumiford 1977).

Excessive pesticide concentrations which violate the EPA criteria for aquatic life and the Corps of Engineers no-discharge criteria have been recorded in Little Lake, Barataria Bay, the Gulf Intracoastal Waterway below Algiers, Bayou Lafourche, Lakes Cataouatche and Salvador, and Lac des Allemands. Bayou Lafourche had pesticide violations for aldrin, parathion, 2,4-D, silvex, and lindane. These pesticides are used in the production of agricultural products and aquatic weed control. The improper disposal of unused pesticides and pesticide containers, agricultural runoff, and direct entry via application are probable routes for these pesticides into the receiving waterbodies (U.S. Army Corps of Engineers

1980). Pesticide residues in Barataria Basin have had an effect on aquatic organisms and bird populations. The brown pelican (Pelicanus occidentalis) population in Louisiana was reduced from an estimated range of 35,000-82,000 birds in 1933 to near extinction in the early 1960's primarily as a result of decreased reproductive capabilities caused by pesticide residues (DDE, dieldrin, and endrin) in adult birds' eggs (Blus et al. 1979). About 800 birds were reintroduced into the Barataria Basin from 1968 to 1976. Another die-off occurred in 1975, coinciding with unusually high endrin residues in the Barataria Bay that spring. High endrin residues were found in the pelican eggs (Blus et al. 1979). Beyond these dramatic examples of pesticide related deaths, few data are available on the impact of chronic toxic input on the biota.

#### 10.6.1 Carcinogen Monitoring in Estuaries

Toxic pollution results in the deteriorating quality of the ecosystem of which human health is a part. Certain types of cancer have a higher incidence in southern Louisiana when compared to the national average. Higher rates of cancer mortality have been statistically linked to drinking water from the Mississippi River, with its variety of chemical carcinogens, and to residents in counties where petroleum industry is most heavily concentrated. (Hoover et al. 1975; Page et al. 1976; Blot et al. 1977). There is also a correlation between respiratory cancer and wetlands residency in Louisiana (Voors et al. 1978).

Stitch et al. (1976) reported that "there is compelling evidence that points to cancer as an ecological disease. A comparison of high with low incidences of tumors in different geographic regions, along with the changes in tumor frequency among immigrant groups and the clustering of many human tumors in industrialized regions in the U.S.A. suggest a strong environmental influence in cancer induction, promotion, or both. Thus, it seems reasonable to apply ecological methodology to uncover the environmental component in cancer formation. The ecological approach may have the further advantage of being highly relevant to man, since it is economical and manageable with the presently available manpower."

A system for carcinogenic monitoring in estuaries using biological and chemical indicators

has recently been developed. A number of microbial organisms, plants, and animals have been suggested as "built in" indicators of water quality. An ideal organism should detect the appearance of a specific group of chemical compounds (i.e., by appearance of tumors), have a fairly uniform distribution over a wide area, survive in contaminated waters, stay within a restricted territory, and be easy to collect in large quantities. A bottom-dwelling flatfish species whose skin tumors are readily diagnosed and counted is a good test organism candidate (Stitch et al. 1976).

The complimentary chemical indicator system uses chemical techniques to directly estimate the amounts of known carcinogens in environmental samples. The chemicals chosen should be representative of a larger group of carcinogenic compounds, detectable in small amounts at a reasonable cost, in samples of a size suitable for collection, and reasonably stable in the environment so that transient discharges can be detected. Promising candidates for the establishment of a "carcinogenic index" are polycyclic aromatic hydrocarbons (PAH). These should be looked for in the water column, bottom sediments, and in marine organisms such as shellfish, which act as bioaccumulators (Stitch et al. 1976).

#### 10.6.2 Toxic Substances Management Guidelines

Several options for controlling toxic substances exist and should be employed:

1. Eliminate toxic input in excess of Federal EPA standards from point sources, such as industrial plants.
2. Avoid dumping toxic sediments any place where materials may contaminate wetlands through erosion or leaching (Darnell 1977). The U. S. Fish and Wildlife Service supports regulations which would require that oil wastes be containerized and removed from wetland areas.
3. During oil and gas exploration and production, knowledge and implementation of an efficient contingency plan for oil spills is imperative. Primary actions should be taken to confine materials to the smallest possible area. All dispersants, emulsifiers and other chemical agents to control the spill should be approved before use. If damage is done to shellfish
4. Biological and mechanical control of water hyacinth should be used instead of chemical spraying of 2,4-D in light of recent health hazards connected with 2,4-D exposure.
5. The use of vascular aquatic plants such as the water hyacinth (*Eichhornia crassipes*) in controlled biological systems should be encouraged as they represent a very efficient and inexpensive filtration and disposal system for toxic materials released into waters near urban/industrial areas (Wolverton et al. 1975).
6. Best agricultural practices applicable to pesticide usage are those which employ proper pesticide selection, proper pesticide application rates, optimal pesticide placement and time, proper disposal of pesticide containers and unused pesticides, use of nonchemical methods, integrated pest management, legal controls, and reduced sediment loss.
7. Hazardous waste sites should not be situated in wetland areas. Management options of hazardous chemicals include the use of the waste for energy generation or resource recovery, chemical fixation of solid wastes through stabilization or solidification, and disposal of liquid and solid wastes by incineration (Darnell 1977; Dow and Garcia 1980) or some other accepted technique.
8. Brine disposal should not be allowed in wetland-estuarine areas. Disposal should take place offshore under controlled conditions where brine does not break the surface of the water or completely cover the water column, thus acting as a barrier.
9. Urban runoff should be controlled by a preventative approach, addressing the sources and causes of pollution. This includes all pre-storm actions directed toward reducing availability of pollutants to storm flows, such as reducing air pollution, avoiding over-application of fertilizers and pesticides, improving street sweeping, periodically flushing collection systems, sewer separation, minimizing exposed land surface during construction, and maintaining good vegetative cover in erodable areas (EPA 1977). Other means of controlling urban runoff are those which directly influence the stormwater path, flow rates, or loadings. Such techniques as temporary storage of stormwater on rooftops,

parking area storage, in-line storage bins or ponds, and use of porous pavement can decrease the amount of water entering a waterbody from each storm. In new

developments, the natural drainage system should be used in its existing undeveloped, grass-covered state in order to slow and reduce runoff by infiltration.



## CHAPTER 11

### SYNTHESIS

by

J. W. Day, Jr., C. S. Hopkins, W. H. Conner, and J. G. Gosselink

In this final chapter we want to summarize and synthesize the information presented about the Barataria Basin in the context of some of the important issues in estuarine and wetland ecology today. Specifically, we will address questions concerning (1) factors affecting aquatic primary productivity, (2) the role of hydrology in the ecosystem, (3) the importance of wetlands in the organic carbon budget of the estuary, and (4) the role of wetlands and estuaries in fisheries production.

#### 11.1 FACTORS AFFECTING AQUATIC PRIMARY PRODUCTIVITY

Aquatic primary productivity was discussed in Chapter 4. We showed that waterbodies in the upper basin are characterized by high productivity, pronounced seasonality, and net heterotrophy. More saline waters have lower net production, lack consistent seasonality, and tend to be slightly autotrophic. The factors controlling productivity change from the upper basin to the gulf. In the

upper basin, nutrient loading from upland runoff seems to be important in controlling both seasonal patterns and the magnitude of production. In the lower basin the water clarity and depth are important. Offshore, Mississippi River flow is the dominant factor controlling productivity.

Lac des Allemands, a fresh, turbid lake in the upper basin (Table 41) that is influenced by adjacent wetlands and upland drainage, is highly eutrophic and has a pronounced seasonal pattern of productivity (Figure 22, Table 5). Productivity patterns in the three lakes of the central basin partially reflect the degree to which upland runoff affects the lakes (Figure 23, Table 5) with production being highest in Lake Cataouatche, which receives high nutrient loading from upland runoff (Hopkinson and Day 1979). Mean annual chlorophyll *a* in the lake is about 50 mg/m<sup>3</sup>. Production is higher in Little Lake, probably because of production by benthic algae (Hopkinson and Day 1979). All three lakes are heterotrophic. Lake Cataouatche with high

**Table 41.** Physical characteristics of waterbodies in the Barataria Basin (from Day et al. 1982).

Ecological zone	Example	Turnovers per year	Depth (m)	Salinity range (ppt)	Secchi depth (cm)	Tidal range (cm)	Upland to wetland + water ratio
Upper basin	Lac des Allemands	4.6	2.0	0	33	3.2	1:2.3
Middle basin	Lake Cataouatche	1.5	2.0	0-3	30	NA	1:6.7
	Lake Salvador	1.0	2.5	0-6	72	8.5	
Lower basin	Little Lake	NA	1.5	0-15	72	12	1:33.3
	Lower Barataria Bay	14.6	2.0	10-35	68	30	

nutrient inputs and turbidity has a similar seasonal pattern of productivity to Lac des Allemands. Lake Salvador also shows distinct seasonality, but to a lesser extent. There is no consistent seasonal pattern in Little Lake, primarily as a result of significant benthic production during times of high water clarity.

Aquatic production in the saline waters of lower Barataria Basin is somewhat higher than in Little Lake (Table 5), but is similar in its lack of a distinct seasonal pattern (Day et al. 1973). The results from both Little Lake and Airplane Lake indicate that benthic algal production is significant.

In the nearshore zone of the Gulf of Mexico adjacent to the basin, primary productivity, chlorophyll *a* concentrations, and assimilation numbers all peaked in spring, when Mississippi River flow reached a maximum, and were correlated with river flow (Sklar and Turner 1981). Thus, there is a clear influence of the river; however, the impacts of estuarine outwelling on the nearshore phytoplankton are not clear. Sklar and Turner (1981) found that during the winter months, when northerly winds decrease the water levels in the basin, there was evidence that the Barataria marshes exported nutrients, and this increased the primary production of the coastal waters.

We believe that in the absence of direct upland runoff, basin water bodies would have two patterns of productivity, depending on whether light reached the bottom. Shallow lakes throughout the basin would have seasonal patterns similar to those observed in Little Lake

and Airplane Lake, while deeper lakes would be similar to Lake Salvador.

Nutrients did not seem to be limiting in freshwater. In more saline waters there is a summer inorganic nitrogen minimum with nutrient limitation. As to which nutrient has the potential to be limiting, N:P ratios are almost always less than 10:1 and often less than 5:1 (Witzig and Day 1983a). Since this is less than the Redfield ratio of 16:1, it suggests that nitrogen is potentially limiting in both fresh and saline waters of the basin.

In an effort to estimate the importance of new nutrient inputs, Day et al. (1982) calculated the amounts of both new and remineralized nutrients for each of the major water bodies in the basin (Table 42). In all cases, estimates of remineralized nitrogen were greater than for new nitrogen. The new inputs were from 26% to 42% of the net demand by phytoplankton. The data also suggest that higher new inputs stimulate remineralization. This is to be expected, since not only will new nutrients stimulate *in situ* production, but runoff high in nitrogen is also high in organic matter, which leads to increased metabolism and mineralization. These results suggest that remineralization is the most important immediate source of nutrients. However, allochthonous sources are important because they can play an important role in determining local metabolism and mineralization rates. These estimates were all calculated indirectly, and thus must be considered tentative. The only validation Day et al. were able to make is that estimated benthic respiration agreed closely with direct measurements from lower Barataria Bay (Hopkinson et al. 1978).

**Table 42.** Estimates of new and remineralized nitrogen as compared to nitrogen demand by phytoplankton in the Barataria Basin (all values in g N/m<sup>2</sup>/yr) (modified from Day et al. 1982).

Location	Net demand by phytoplankton	Remineralized N		
		Benthic	Water column	New N
Lac des Allemands	77	17	28	32
Lake Cataouatche	47	16	20	11
Lake Salvador	22	2	16	4
Barataria Bay	51	12	31	8

## 11.2 THE ROLE OF HYDROLOGY IN THE ECODYNAMICS OF THE BARATARIA BASIN

Hydrology is a critical process in estuarine and wetland ecosystems. In this section we want to briefly review evidence from the Barataria Basin on the role of hydrology.

One of the most striking aspects about salt marshes is the higher productivity of grasses near the water's edge versus inland sites. This has been demonstrated for the lower Barataria Bay salt marshes by Kirby and Gosselink (1976). This difference in productivity is related to the degree of waterlogging of soil and nutrient supply (Howes et al. 1981). In inland marshes, drainage is poor and soils are almost always anaerobic. Mendelsohn et al. (1981) demonstrated that *Spartina alterniflora* actually shifts to anaerobic metabolism. Prolonged waterlogging may also be partially responsible for areas of *Spartina* "die back" (Smith 1970).

Because of the low range of water level variation in the Barataria Basin, wetland plants exist within a relatively small elevational range (Sasser 1977; Baumann 1980) (Figure 62). The combination of high subsidence rates and lack of riverine sediment is causing the loss of large areas of marshes (Baumann 1980; Baumann et al. 1984). Conner and Day (1976) showed that slight elevational differences of about 15 cm determined whether cypress-tupelo or bottomland hardwood species grow in the forested wetlands of the upper basin.

Human activities have greatly altered the hydrology of the Barataria Basin, both by altering the pathways of water movement and by changing the rate of water exchange in aquatic and wetland areas. These changes can best be understood by a comparison with the natural hydrologic regime of the basin. As discussed in Chapter 2, tidally introduced saline waters from the Gulf of Mexico once slowly moved upbasin and mixed with fresh water from precipitation and the river. The flow moved through shallow sinuous bayous such as Grand Bayou, Bayou St. Denis, and Bayou des Allemands as well as overland through wetlands. Water running off the natural levees flowed slowly through wetlands before reaching bayous, lakes, and bays located along the central axis of the basin. Overall, net water movement was gulfward,

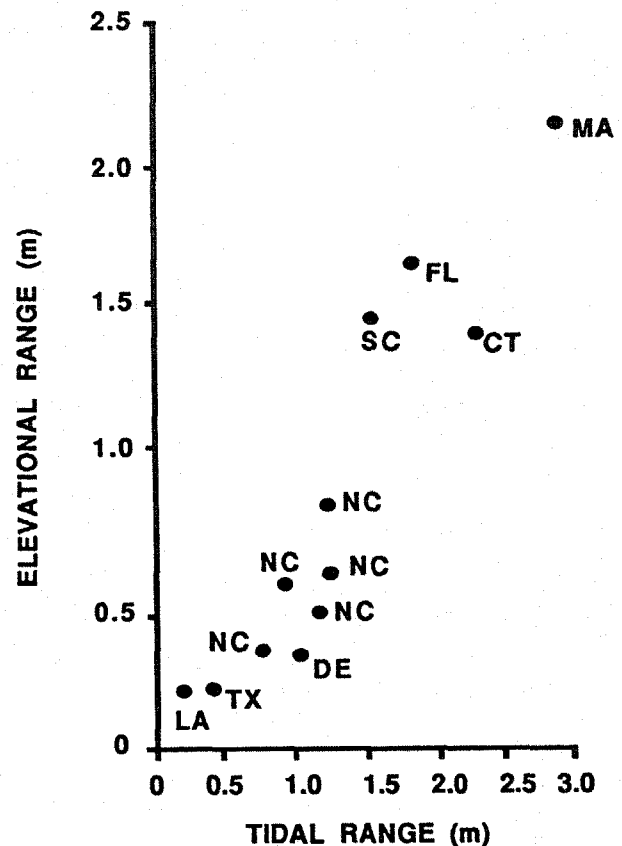


Figure 62. Elevation range of *Spartina alterniflora* along Atlantic and gulf coasts versus tidal range (Baumann 1980).

but there was much sloshing back and forth of the water masses.

Human activities have short-circuited many of these water flows. A large part of the natural levee runoff bypasses wetlands and is now shunted through a series of canals directly into basin waterways. For example, the St. James canal carries water which once flowed through swamp forests of the upper basin directly into Bayou Chevreuil and then into Lac des Allemands. Likewise, the Bayou Segnette Waterway shunts runoff from urbanized areas near New Orleans directly into Lake Cataouatche. A major impact of these changes is that sediment and nutrient-laden water enter waterbodies, leading to nutrient loading and extreme eutrophication (Butler 1975; Hopkinson and Day 1977; Day et al. 1977, 1982; Witzig and Day 1983b).

Dredged canals have also led to more direct water exchange between the upper and lower basin. A comparison of primitive and present water movement patterns illustrates this point (Figure 59). Under natural conditions, to get to the gulf, water from Lake Cataouatche flowed into Lake Salvador, through Bayous Barataria, Rigolettes, and Perot to Little Lake, then through Grand Bayou and Bayou St. Denis to Barataria Bay. Now upland runoff entering Lake Cataouatche can flow much more directly to Barataria Bay via the Bayou Segnette and Barataria Bay Waterways. Another impact of these new connections is that salt water intrusion has become much more of a problem (Van Sickle et al. 1976).

While water interchange among water bodies in the basin has increased with the changes described above, the rate of water exchange in wetlands has decreased. Accompanying the dredging of numerous canals for such purposes as drainage, navigation, and pipeline and rig access there has been the deposition of spoil banks, which limit water exchange (Swenson 1982). Often spoil banks dredged for different purposes link up to form impounded and semi-impounded areas. One well studied example discussed in several chapters is the area of impounded swamp forest west of des Allemands (Sklar and Conner 1979, 1983; Bowers 1981; Conner et al. 1981; Sklar 1983). This area was unintentionally impounded in 1955 when spoil banks from the dredging of Bayou Chevreuil, the embankment for State Highway 20, and an oil access road, linked with a low ridge to form a permanently flooded area of swamp. Impounding has caused a number of significant changes. The area has opened up significantly, with many adult trees dying. Few new seedlings have become established, and the overall primary productivity is lower (Conner et al. 1981). As the forest opened up, dense mats of floating vegetation (duckweed and water hyacinth) became much more common. Sklar (1983) found that while the majority of benthic organisms lived in the bottom sediments in natural swamps, they were found primarily in the floating vegetation in the impoundment. This was primarily because of the reduced conditions in the sediments. Organic export was less from the impounded swamp (Sklar et al. 1984).

Another factor which seems to be related to the construction of canals and spoil banks is the rate of land loss. Craig et al. (1979) and Scaife et

al. (1983) both showed that canal density was positively correlated with land loss in coastal Louisiana. Blackmon (1979) found the same relationships for marshes in the Barataria Basin. These findings are related to a number of factors including lowered sedimentation rates and waterlogging of soils. New sediments are important both to offset subsidence (Baumann et al. 1984) and as an important source of nutrients (Day et al. 1982; DeLaune and Patrick 1980).

### 11.3 WETLANDS AND THE ESTUARINE CARBON BUDGET

Because of the great expanse of periodically flooded marshes and swamps in the Mississippi River Deltaic Plain, one might expect these wetlands to play a major role in controlling or augmenting the productivity of adjacent freshwater and estuarine ecosystems. Day et al. (1982) constructed an annual organic carbon budget for Barataria Basin from a combination of direct and indirect measurements of carbon fluxes (Table 43).

The Barataria Basin carbon budget indicates that all aquatic habitats are strongly dependent on imported organic matter, and that upstream habitats are significant sources of organic matter for downstream habitats. The portion of wetland primary production exported to adjacent water bodies is lowest in the swamp (2%) and greatest in the salt marsh (30%). Research in both the Barataria Basin and in Lake Pontchartrain show that bayous, canals, and lake edges that are contiguous with wetlands have higher levels of nutrients and organic matter than open water areas (Cramer 1978; Seaton 1979; Witzig and Day 1983b). *In situ* production and carbon inputs from other habitats exceed carbon outputs from respiration and sedimentation in all aquatic habitats. Upstream production provides from 9% to 30% of total carbon inputs to the different water bodies.

The mass balance technique used to calculate the carbon budget depends to some extent on fluxes calculated by difference, so the resulting budget cannot be validated. Considerable data, however, exist to show (1) that carbon in significant quantities is exported from the estuaries into the gulf; (2) that carbon is exported from wetlands to adjacent water bodies; and (3) that downstream export of carbon affects

**Table 43.** Annual organic carbon budget for Barataria Basin (all carbon flows in g C/yr x 10<sup>12</sup>) from Day et al. 1982.

Habitat	Area (m <sup>2</sup> x 10 <sup>8</sup> )	Total net production	Export	Respiration	Sedimentation
Des Allemands swamp	10.30	69.94	1.75		
Des Allemands aquatic	0.65	3.15	0.65	4.04	0.21
Lake Cataouatche wetlands	2.20	19.75	1.58		
Lake Cataouatche aquatic	0.37	1.10	1.04	1.52	0.12
Fresh wetlands	4.20	37.72	3.01		
Fresh aquatic	1.90	2.59	2.21	3.91	1.17
Brackish wetlands	5.50	115.22	14.97		
Brackish aquatic	4.83	10.49	10.41	12.43	4.83
Saline wetlands	6.34	67.52	20.26		
Saline aquatic	8.21	26.23	12.38	25.55	18.97
Nearshore Gulf of Mexico	15.00	39.90			

primary productivity of aquatic habitats. Direct measurements of organic carbon export have been collected from Lac des Allemands to Lake Salvador (Day et al. 1977) and from Barataria Bay to the Gulf of Mexico (Happ et al. 1977).

#### 11.4 THE ROLE OF THE MARSH-ESTUARY IN FISHERIES PRODUCTION

Louisiana has the greatest area of coastal wetlands (Turner and Gosselink 1975) and the largest commercial fishery in the United States (see U.S. Fishery statistics). It is commonly held that the coastal wetlands play an important role in supporting the fisheries (Lindall and Saloman 1977). We believe that there is strong evidence which shows coupling between fisheries and the marsh estuarine system, and in this section we review several lines of evidence from the Barataria Basin.

There have been over 20 studies of nekton community composition, biomass distribution, and migratory patterns in the basin.

Bay anchovy, croaker, sea catfish, striped mullet, spot, menhaden, silverside, and shrimp comprise 80% to 95% of the total numbers and biomass (Gunter 1936, 1938a, 1938b; Perret et al. 1971; Wagner 1973; Sabins and Truesdale 1974; Chambers 1980).

The bay anchovy is an estuarine resident that normally completes its entire life cycle within the estuary. Other species spawn offshore and use the estuary as a nursery and feeding ground. Studies indicate that there are fairly specific, repeating patterns in the way nekton species use the Barataria Basin. For example, Sabins and Truesdale (1974) identified over 80 species of juvenile fishes that migrated through Caminada Pass. They identified a "warm water fauna" composed mainly of the young of inshore spawners and a "cold water fauna" composed predominantly of the young of offshore spawners. Wagner (1973) classified the majority of fishes in a number of marsh and estuarine habitats in the Caminada Bay area as seasonal migrants using the estuary for spawning, feeding, or as a nursery.

Chambers (1980) presented a diagram of the pattern of use of the basin by four different nekton groups (Figure 63): (1) euryhaline larvae, postlarvae, and juveniles of marine nekton, which spawn offshore, migrate far up the basin in the late winter and spring, and then gradually move downbay as they grow, eventually emigrating to the gulf in later summer and fall; (2) juvenile and adult freshwater species, which move southward in the fall into oligohaline areas as they become fresher and replace the emigrating marine species, returning to fresh areas in the late winter; (3) mesohaline juveniles of certain marine species which move out to the midgulf in the late fall and winter as salinities decrease; (4) some euryhaline species which spend their entire life cycles in the estuary and often may be found anywhere from the freshwater swamps to the lower bays and barrier islands bordering the gulf. The data of both Wagner (1973) and Chambers (1980) suggest that

euryhaline marine-spawned juveniles preferentially migrate into water with low salinity and slowly move into waters of higher salinity as they grow. Wagner found that less saline areas were characterized by high densities of postlarvae and juveniles. By contrast, biomass was higher in the more saline areas because of the presence of large juveniles and adults.

Nekton species, especially larval and juvenile forms, preferentially seek out shallow water adjacent to wetlands, such as marsh ponds, tidal creeks, and the marsh edge in general. Data from Barataria Basin and Lake Pontchartrain show that nekton biomass is 7 to 12 times higher in shallow water marsh areas as compared with open waters. This pattern has also been demonstrated on the east coast where shallow tidal creeks and marsh shoals harbor dense populations of juvenile marine species (Schenker and Dean 1979;

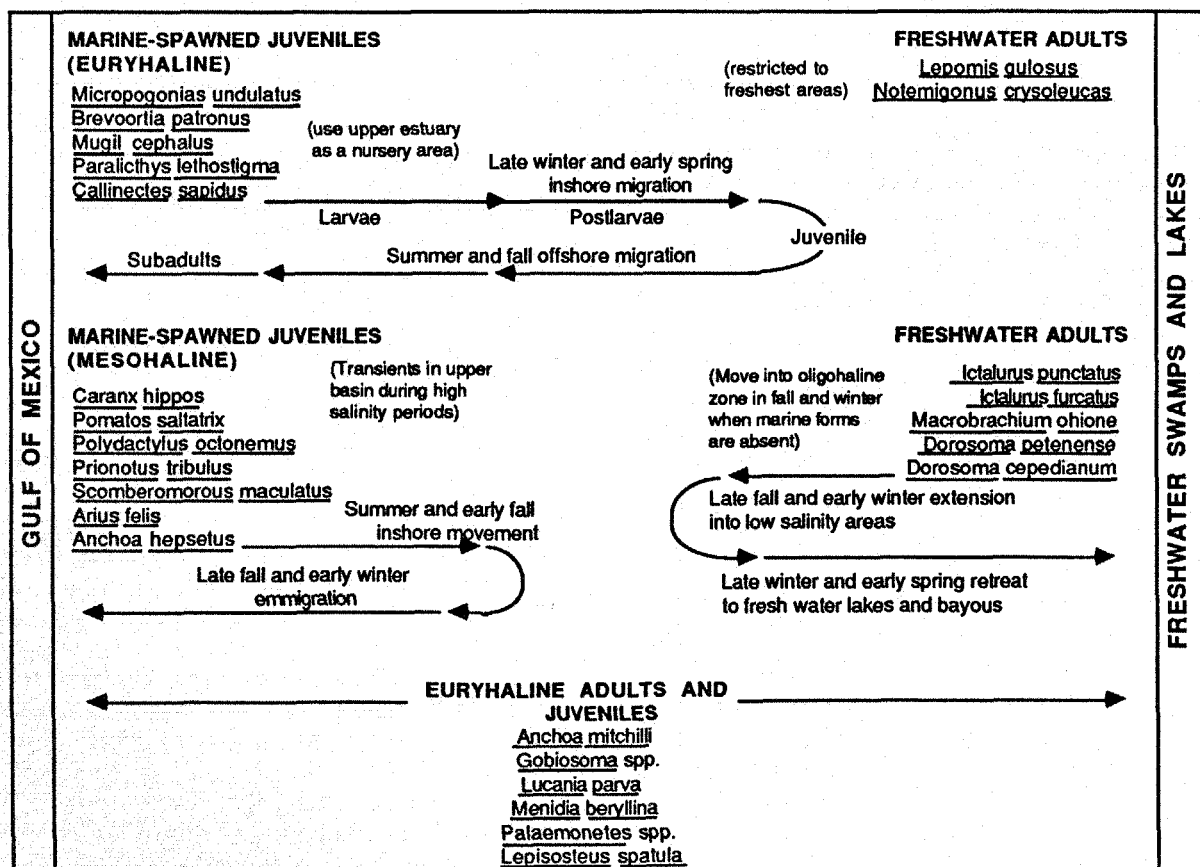


Figure 63. Patterns of estuarine use by nektonic organisms (reprinted, with permission, from Day et al. 1982, copyright Academic Press).

Weinstein 1979; Bozeman and Dean 1980) and that young fish actively seek creek headwaters.

It may be that it is primarily the shallow nature of waters adjacent to wetlands that attracts nekton seeking either food or refuge from predators. This is undoubtedly at least partially true, since these areas are practically all <1 m deep. However, most open waters in the Barataria Basin are <2 m deep and many are <1 m. The lakes and bays of the basin have flat, shallow bottoms. Since there is a distinct biomass difference between open waters and near marsh waters, it must be caused by more than the shallow nature of these areas.

A number of studies have shown correlations among estuaries, wetlands, and fisheries. Turner (1977) correlated shrimp yield (kg/ha) and intertidal wetland areas on a worldwide basis. On a regional basis (the northern Gulf of Mexico), he found that yields of inshore shrimp are directly related to the area of estuarine vegetation, whereas they are not correlated with area, average depth, or volume of estuarine water. Moore et al. (1970) presented data on distribution of demersal fish off Louisiana and Texas. Their data suggest that the greatest fish populations occur offshore

from extensive wetlands with a high freshwater input. Bahr et al. (1983) quantified organic matter flow in the Louisiana coastal zone. Their analysis showed a quantitative relationship between gross primary production of aquatic upper level consumers. They concluded that all input energy (from primary production) was used in the system or exported. This suggests that any reduction in primary production would be reflected in reduced secondary production, including the harvest of fishery species. They also stressed that habitat quality is also important in fisheries production. Thus the source of primary organic matter must be considered. Nevertheless, the Barataria Bay does seem to be in balance in terms of production and consumption.

The evidence from Barataria Basin and elsewhere in Louisiana suggests that wetlands enhance fisheries productivity. The picture is certainly not complete, and we know that very few nekton species are absolutely dependent on estuaries or wetlands. However, the available data do suggest specific ways that nekton use wetlands. It is probable that many nekton species have evolved behavioral patterns that allow them to exploit wetlands as both food sources and habitat.





## LITERATURE CITED

- Abernethy, R.K. 1986. Environmental conditions and waterfowl use of a backfilled pipeline canal. M.S. Thesis. Louisiana State University, Baton Rouge. 125 pp.
- Abernethy, R.K., G.W. Peterson, and J.G. Gosselink. 1985. A small mammal trapping study of the floating freshwater marshes surrounding Lake Boeuf, Louisiana. *Northeast Gulf Sci.* 7:177-180.
- Adams, R.D., B.B. Barrett, J.H. Blackmon, B.W. Gane, and W.G. McIntire. 1976. Barataria Basin: geologic processes and framework. Louisiana State University, Center for Wetland Resources, Baton Rouge. Sea Grant Publ. No. LSU-T-76-006. 117 pp.
- Adams, R.D., P.J. Banas, R.H. Baumann, J.H. Blackmon, and W.G. McIntire. 1978. Shoreline erosion in coastal Louisiana: inventory and assessment. Louisiana Department of Transportation and Development, Baton Rouge. 139 pp.
- Alexander, M.L. 1922. Report of the Commissioner of Conservation. Fifth Biennial Report, Department of Conservation, State of Louisiana, for 1920-22, pp.7-17.
- Alexander, T.R. 1967. Effect of Hurricane Betsy on the southeastern Everglades. *Q. J. Fla. Acad. Sci.* 30:10-24.
- Allen, D. 1979. Documentations of the use of a brackish water estuarine zone as a nursery ground by Penaeid shrimp. M.S. Thesis. Louisiana State University, Baton Rouge. 91 pp.
- Allen, R.L. 1975. Aquatic primary productivity in various marsh environments in Louisiana. M.S. Thesis. Louisiana State University, Baton Rouge. 50 pp.
- Austin, B.B. 1955. Current survey west Barataria Bay, Louisiana. Report to the Texas company dated 18 March 1955 (with supplement).
- Bahr, L.M., Jr., and J.H. Hebrard. 1976. Barataria Basin: biological characterization. Louisiana State University, Center for Wetland Resources, Baton Rouge. Sea Grant Publ. No. LSU-T-76-005. 144 pp.
- Bahr, L.M., Jr., R. Costanza, J.W. Day, S.E. Bayley, C. Neill, S.G. Leibowitz, and J. Fruci. 1983. Ecological characterization of the Mississippi deltaic plain region: a narrative with management recommendations. U.S. Fish Wildl. Serv. FWS/OBS-82/69. 189 pp.
- Barbour, R.W., and W.H. Davis. 1969. Bats of America. The University of Kentucky Press, Lexington. 286 pp.
- Barrett, B., J. Merrell, T. Morrison, M. Gillespie, E. Ralph, and J. Burdon. 1978. A study of Louisiana's major estuaries and adjacent offshore waters. La. Dep. Wildl. Fish. Tech. Bull. No. 27. 197 pp.
- Bateman, H.A. 1965. Clapper rail (Rallus longirostris) studies on Grand Terre Island, Jefferson Parish, Louisiana. M.S. Thesis. Louisiana State University, Baton Rouge. 145 pp.
- Baynard, O. 1912. Food of herons and ibis. *Wilson Bull.* 24:167-169.
- Baumann, R.H. 1980. Mechanisms for maintaining marsh elevation in a subsiding environment. M.S. Thesis. Louisiana State University, Baton Rouge. 92 pp.
- Baumann, R.H., and R.D Adams. 1981. The creation and restoration of wetlands by natural processes in the lower Atchafalaya River

- system: possible conflicts with navigation and flood control management. Pages 1-24 in R.H. Stovall, ed. Proc. 8th Annu. Conf. Wetlands Restoration and Creation. Hillsborough Community College, Tampa, Fla.
- Baumann, R.H., J.W. Day, Jr., and C.A. Miller. 1984. Mississippi deltaic wetland survival: sedimentation vs. coastal submergence. *Science* 224:1093-1095.
- Beck, L.T. 1977. Distribution and relative abundance of freshwater macroinvertebrates of the lower Atchafalaya River Basin, Louisiana. M.S. Thesis. Louisiana State University, Baton Rouge. 163 pp.
- Behre, E.H. 1950. Annotated list of the fauna of the Grand Isle region, 1928-1946. *Occas. Pap. Mar. Lab. La. State Univ.* 6:1-66.
- Blackmon, J.H., Jr. 1979. A detailed analysis of marsh deterioration for selected sites in the Barataria Basin, Louisiana. Pages 211-226 in J.W. Day, Jr., D.D. Culley, Jr., R.E. Turner, and A.J. Mumphrey, Jr., eds. Proc. Third Coastal Marsh and Estuary Management Symposium. Louisiana State University Division of Continuing Education, Baton Rouge.
- Blegvad, H. 1928. Quantitative investigations of bottom invertebrates in the Limfjord 1910-1927 with special reference to the plaice food. *Rep. Dan. Biol. Stn.* 34:33-52.
- Bloom, A.L. 1977. Atlas of sea level curves. International Geologic Correlation Program, Project 61, IGCP Sea Level Project. IUGS, IGCP, UNESCO.
- Blot, W.J., L.A. Brinston, J.F. Fraumeni, and B.J. Stone. 1977. Cancer mortality in U.S. counties with petroleum industries. *Science* 198:51-53.
- Blus, L.J., E. Cromartie, L. McNease, and T. Joanen. 1979. Brown pelican: population status, reproductive success, and organochlorine residues in Louisiana, 1971-1976. *Bull. Environ. Contam. Toxicol.* 22:128-134.
- Boesch, D.F. 1977. Application of numerical classification in ecological investigations of water pollution. U.S. Environ. Protect. Agency Ecol. Res. Ser. EPA-600/3-77-033.
- Boesch, D.F. 1983. Implications of oxygen depletion on the Continental Shelf of the northern Gulf of Mexico. *Coast. Ocean Poll. Assess. News* 2(3):25-28.
- Bouchard, J.W., and C.R. Turner. 1976. Zooplankton. App. VI, Sect. 7 in J.G. Gosselink, R.R. Miller, M.A. Hood, and L.M. Bahr, eds. Louisiana Offshore Oil Port: environmental baseline study. LOOP, Inc., New Orleans, La.
- Bowers, L.J. 1981. Tree ring characteristics of baldcypress in varying flooding regimes in the Barataria Basin, Louisiana. Ph.D. Dissertation. Louisiana State University, Baton Rouge. 159 pp.
- Boyd, C.E. 1969. Production, mineral nutrient absorption, and biochemical assimilation by *Justicia americana* and *Alternanthera philoxeroides*. *Arch. Hydrobiol.* 66:139-160.
- Bozeman, E.L., and J.M. Dean. 1980. The abundance of estuarine larval and juvenile fish in a South Carolina creek. *Estuaries* 3:89-97.
- Brezonik, P.L., and E.E. Shannon. 1971. Trophic state of lakes in north central Florida. *Fla. Water Resour. Res. Cen. Publ. No. 13.* 102 pp.
- Brodthmann, N.V., Jr. 1976. Continuous analysis of chlorinated hydrocarbon pesticides in the lower Mississippi River. *Bull. Environ. Contam. Toxicol.* 15:33-39.
- Broome, S.W., W.W. Woodhouse, and E.D. Seneca. 1975. The relationship of mineral nutrients to growth of *Spartina alterniflora* in North Carolina. Vol 2: The effects of N, P, and Fe fertilizers. *Soil Sci. Soc. Am. Proc.* 39:301-307.
- Broussard, W. 1982. Salinity trends in Barataria Bay, 1979. *La. Dep. Wildl. Fish. Tech. Bull.* 35:69-82.
- Brown, C.A. 1972. Wildflowers of Louisiana and adjoining states. Louisiana State University Press, Baton Rouge. 247 pp.

- Brunett, L., and D. Wills. 1981. A guide to wildlife management areas. Louisiana Department of Wildlife and Fisheries, New Orleans. 92 pp.
- Bryan, C.F., D.J. Demont, D.S. Sabins, and J.P. Newman. 1976. A limnological survey of the Atchafalaya Basin, annual report. La. Coop. Fish. Unit., School of Forestry and Wildlife Management, Louisiana State University, Baton Rouge. 285 pp.
- Buresh, R.J., R.D. DeLaune, and W.H. Patrick, Jr. 1980. Nitrogen and phosphorous distribution and utilization in a Louisiana gulf coast marsh. *Estuaries* 3:111-121.
- Burke, W.W. 1976. Vertical and horizontal distribution of macroinvertebrates on the cord grass, *Spartina alterniflora* in a Louisiana salt marsh. M.S. Thesis. Louisiana State University, Baton Rouge. 117 pp.
- Burt, W.H., and R.P. Grossenheider. 1964. A field guide to the mammals. Houghton Mifflin Company, Boston. 284 pp.
- Butler, T.J. 1975. Aquatic metabolism and nutrient flux in a south Louisiana swamp and lake system. M.S. Thesis. Louisiana State University, Baton Rouge. 58 pp.
- Byrd, W., and C. Smith. 1985. The good olde days are now. *La. Conserv.* 36(6):24-28.
- Byrne, P.A., M. Borengasser, G. Drew, R.A. Muller, B.L. Smith, Jr., and C. Wax. 1976. Barataria Basin: hydrologic and climatologic processes. Louisiana State University, Center for Wetland Resources, Baton Rouge. Sea Grant Publ. No. LSU-T-76-010. 176 pp.
- Cary, L.R. 1907. A preliminary study of the conditions for oyster culture in the water of Terrebonne Parish, Louisiana. *Gulf Biol. Stn. Bull.* 9:4-62.
- Casselman, M.E. 1979. Biological nitrogen fixation in a Louisiana gulf coast salt marsh. M.S. Thesis. Louisiana State University, Baton Rouge. 82 pp.
- Casselman, M.E., W.H. Patrick, Jr., and R.D. DeLaune. 1981. Nitrogen fixation in a gulf coast salt marsh. *Soil Sci. Soc. Am. J.* 45:51-56.
- Chabreck, R.H. 1966. Methods of determining the size and composition of alligator populations in Louisiana. *Proc. Southeast. Game Fish Comm. Conf.* 20:105-112.
- Chabreck, R.H. 1970. Marsh zones and vegetative types in Louisiana coastal marshes. Ph.D. Dissertation. Louisiana State University, Baton Rouge. 113 pp.
- Chabreck, R.H. 1971. The foods and feeding habits of alligators from fresh and saline environments. *Proc. Southeast. Assoc. Game Fish Comm. Conf.* 25:117-124.
- Chabreck, R.H. 1972. Vegetation, water, and soil characteristics of the Louisiana coastal region. La. State Univ., Baton Rouge. *Agric. Expt. Stn. Bull. No. 664.* 72 pp.
- Chabreck, R.H., and G. Linscombe. 1978. Vegetative type map of the Louisiana and coastal marshes. Louisiana Department of Wildlife and Fisheries, New Orleans. 1 pp.
- Chamberlain, J.L. 1959. Gulf coast marsh vegetation as food of wintering waterfowl. *J. Wildl. Manage.* 23:97-102.
- Chambers, D.G. 1980. An analysis of nekton communities in the upper Barataria Basin, Louisiana. M.S. Thesis. Louisiana State University, Baton Rouge. 286 pp.
- Chew, F. 1962. Sea-level changes along the northern coast of the Gulf of Mexico. *Trans. Am. Geophys. Union* 45(1):272-280.
- Cleveland, C.J., C. Neill, and J.W. Day, Jr. 1981. The impacts of artificial canals on land loss in the Barataria Basin, Louisiana. Pages 425-433 in W.J. Mitsch, R.W. Bosserman, and J.M. Klopatek, eds. *Energy and ecological modeling.* Elsevier Scientific Publishing Company, Amsterdam.
- Coenen, N.L., and B. Cortright. 1979. Mitigation in the Oregon coastal management program. Pages 103-107 in G.A. Swanson, tech. coord. *The mitigation symposium: a national workshop*

- on mitigating losses of fish and wildlife habitats. U.S. Dep. Agric., For. Serv. Gen. Tech. Rep. RM-65.
- Coleman, J.M., and S.M. Gagliano. 1964. Cyclic sedimentation in the Mississippi River Deltaic plain. *Trans. Gulf Assoc. Geol. Soc.* 14:67-80.
- Conant, R. 1975. A field guide to reptiles and amphibians of eastern and central North America. Houghton Mifflin Co., Boston, Mass. 429 pp.
- Conner, W.H., and J.W. Day, Jr. 1976. Productivity and composition of a baldcypress-water tupelo site and a bottomland hardwood site in a Louisiana swamp. *Am. J. Bot.* 63:1354-1364.
- Conner, W.H., R.E. Noble, and J.W. Day, Jr. 1975. Plant species checklist for the Lac des Allemands swamp area of Louisiana. La. State Univ., Agric. Expt. Stn.. LSU Forestry Note No. 113. 5 pp.
- Conner, W.H., J.G. Gosselink, and R.T. Parrondo. 1981. The effect of altered hydrology on vegetative composition and productivity in a Louisiana swamp. *Am. J. Bot.* 68:320-331.
- Conner, W.H., C.E. Sasser, and N. Barker. 1986. Floristics of the Barataria Basin wetlands, Louisiana. *Castanea* 51:111-128
- Conover, R.J. 1956. Oceanography of Long Island Sound, 1952-1954. 4. Biology of *Acartia clausi* and *A. tonsa*. *Bull. Bingham Oceanogr. Collect. Yale Univ.* 15:156-233.
- Costanza, R., and C. Neill. 1984. Energy intensities, interdependence, and value in ecological systems: a linear programming approach. *J. Theor. Biol.* 106:41-57.
- Costanza, R., C. Neill, S.G. Leibowitz, J.R. Fruci, L.M. Bahr, Jr., and J.W. Day, Jr. 1983. Ecological models of the Mississippi deltaic plain region: data collection and presentation. U.S. Fish Wildl. Serv. Biol. Serv. Program FWS/OBS-82/68. 340 pp.
- Courtier, A. 1938. Marees. Service Hydrographique de la marine, Paris. p. 149.
- Cowardin, L.M., V. Carter, F.C. Golet, and E.T. LaRoe. 1979. Classification of wetlands and deepwater habitats of the United States. U.S. Fish Wildl. Serv. Biol. Serv. Program FWS/OBS-79/31. 103 pp.
- Craig, N.J., and J.W. Day, Jr. 1977. Cumulative impact studies in the Louisiana coastal zone: eutrophication and land loss. La. State Univ., Center for Wetland Resources, Baton Rouge. Final Report to Louisiana State Planning Office. 157 pp.
- Craig, N.J., and J.W. Day, Jr. 1981. Barataria Basin management guidelines. La. State Univ. Coastal Ecology Lab. Report for Coastal Zone Management, Dep. of Natural Resources, Baton Rouge, La. 72 pp.
- Craig, N.J., R.E. Turner, and J.W. Day, Jr. 1979. Land loss in coastal Louisiana (USA). *Environ. Manage.* 3:133-144.
- Cramer, G.W. 1978. A nutrient study in the St. Charles Parish wetlands adjacent to Lake Pontchartrain, Louisiana. M.S. Thesis. Louisiana State University, Baton Rouge. 51 pp.
- Cramer, G.W., J.W. Day, Jr., and W.H. Conner. 1981. Productivity of four marsh sites surrounding Lake Pontchartrain, Louisiana. *Am. Midl. Nat.* 106:65-72.
- Crow, J.H., and K.B. MacDonald. 1978. Wetland values: secondary production. Pages 146-161 in P.E. Greeson, J.R. Clark, and J.E. Clark, eds. Wetland functions and values: the state of our understanding. American Water Resources Association, Minneapolis.
- Cruz-Orozco, R. 1971. Suspended solids concentrations and their relations to other environmental factors in selected water bodies in the Barataria Bay region of south Louisiana. M.S. Thesis. Louisiana State University, Baton Rouge. 110 pp.
- Cumiford, H.F. 1977. An evaluation of PCB levels in Louisiana. An unpublished report by U.S. Environmental Protection Agency, Region VI, Surveillance and Analysis Division, Houston, Tex.

- Cummins, K.W. 1973. Trophic relations of aquatic insects. *Annu. Rev. Entomol.* 18:183-206.
- Cuzon du Rest, R. 1963. Distribution of the zooplankton in the salt marshes of southeastern Louisiana. *Publ. Inst. Mar. Sci. Univ. Tex.* 9:132-155.
- Dando, P.R. 1984. Reproduction in estuarine fish. Pages 155-170 in G.W. Potts and R.J. Wootton, eds. *Fish reproduction strategies and tactics.* Academic Press, London, England.
- Darnell, R.M. 1959. Studies of the life history of the blue crab (*Callinectes sapidus* Rathbun) in Louisiana waters. *Trans. Am. Fish. Soc.* 88(4): 294-304.
- Darnell, R.M. 1961. Trophic spectrum of an estuarine community based on studies of Lake Pontchartrain, Louisiana. *Ecology* 42(2):553-568.
- Darnell, R.M. 1962. Ecological history of Lake Pontchartrain, an estuarine community. *Am. Midl. Nat.* 68(2):434-445.
- Darnell, R.M. 1967. Organic detritus in relation to the estuarine ecosystem. Pages 376-382 in G.H. Lauff, ed. *Estuaries.* Publ. No. 83, American Association for the Advancement of Science, Washington, D.C.
- Darnell, R.M. 1977. Overview for major development impacts on wetlands. *Proc. Natl. Wetland Prot. Symp.,* Reston, Va. U.S. Fish Wildl. Serv. Biol. Serv. Program. FWS/OBS-78/97.
- Davis, C.C. 1950. Observations of plankton taken in marine waters of Florida in 1947 and 1948. *Q. J. Fla. Acad. Sci.* 12(2):67-103.
- Dawson, C.E. 1966. Additions to the known marine fauna of Grand Isle, Louisiana. *Proc. La. Acad. Sci.* 29:175-180.
- Day, J.W., Jr., and N.J. Craig. 1982. Comparison of the effectiveness of management options for wetland loss in the coastal zone of Louisiana. Pages 232-239 in D.F. Boesch, ed. *Proceedings Conference on Coastal Erosion and Wetland Modification: causes, consequences, and options.* U.S. Fish Wildl. Serv. Biol. Serv. Program. FWS/OBS-82/59.
- Day, J.W., Jr., W.G. Smith, P. Wagner, and W. Stowe. 1973. Community structure and carbon budget in a salt marsh and shallow bay estuarine system in Louisiana. La. State Univ. Center for Wetland Resources, Baton Rouge. Sea Grant Publ. No. LSU-SG-72-04.
- Day, J.W., Jr., T.J. Butler, and W.H. Conner. 1977. Productivity and nutrient export studies in a cypress swamp and lake system in Louisiana. Pages 255-269 in M. Wiley, ed. *Estuarine processes.* Vol 2. Academic Press, New York.
- Day, J.W., Jr., C.S. Hopkinson, and W.H. Conner. 1982. An analysis of environmental factors regulating community metabolism and fisheries production in a Louisiana estuary. Pages 121-136 in V.S. Kennedy, ed. *Estuarine comparisons.* Academic Press, New York.
- Deegan, L.A., and B.A. Thompson. In press. Ecology of fish communities in the Mississippi River Deltaic Plain. In A. Yanez-Arancibia, ed. *Fish community ecology in estuaries and coastal lagoons: towards an ecosystem integration.* UNAM-ICML Publ. Mexico City, Mexico.
- Deegan, L.A., H.M. Kennedy, and R. Costanza. 1983. Factors contributing to marsh land loss in Louisiana's coastal zone. Pages 915-919 in W.K. Lauenroth, G.V. Skogerboe, and M. Flug, eds. *Analysis of ecological systems: state-of-the-art in ecological modeling.* Elsevier Scientific Publishing Company, Amsterdam.
- Deegan, L.A., H.M. Kennedy, and C. Neill. 1984. Natural Factors and human modifications contributing to marsh loss in Louisiana's Mississippi River Deltaic Plain. *Environ. Manage.* 8(6):519-528.
- DeLaune, R.D., and W.H. Patrick. 1980. Nitrogen and phosphorus cycling in a gulf coast salt marsh. Pages 143-152 in V. Kennedy, ed. *Estuarine perspectives.* Academic Press, New York.
- DeLaune, R.D., and C.J. Smith. 1984. The carbon cycle and the rate of vertical

- accumulation of peat in the Mississippi River deltaic plain. *Southeast. Geol.* 25(2):61-69.
- DeLaune, R.D., W.H. Patrick, Jr., and R.J. Buresh. 1978. Sedimentation rates determined by  $^{137}\text{Cs}$  dating on a rapidly accreting salt marsh. *Nature* 275:532-533.
- DeLaune, R.D., R.J. Buresh, and W.H. Patrick, Jr. 1979. Relationship of soil properties to standing crop of biomass of *Spartina alterniflora* in a Louisiana marsh. *Estuarine Coastal Mar. Sci.* 8:477-487.
- DeLaune, R.D., C.N. Reddy, and W.H. Patrick, Jr. 1981. Accumulation of plant nutrients and heavy metals through sedimentation processes and accretion in a Louisiana salt marsh. *Estuaries* 4:328-334.
- DeLaune, R.D., C.J. Smith, and W.H. Patrick, Jr. 1983. Nitrogen losses from a Louisiana gulf coast salt marsh. *Estuarine Coastal Shelf Sci.* 17:133-141.
- DeLaune, R.D., C.J. Smith, and M.N. Sarafgan. 1986. Nitrogen cycling in a freshwater marsh of *Panicum hemitomon* on the deltaic plain of the Mississippi River. *J. Ecol.* 74:249-250.
- DeNoux, G.J. 1976. A study of the plankton community of the Calcasieu estuary, Louisiana. M.S. Thesis. Louisiana State University, Baton Rouge. 90 pp.
- Dow, D., and R.I. Garcia. 1980. Hazardous chemical waste problem in Louisiana: environmental fate and effects, Federal and State regulations, and waste disposal options. Institute of Environmental Studies, Louisiana State University, Baton Rouge. 129 pp.
- Dugoni, J.E. 1980. Habitat utilization, food habits, and productivity of nesting southern bald eagles in Louisiana. M.S. Thesis. Louisiana State University, Baton Rouge. 150 pp.
- Eckenrod, R.M., J.W. Day, Jr., and L.M. Bahr. 1979. Computer simulation of urban-estuarine interactions in the New Orleans region. Pages 83-106 in R.F. Dame, ed. *Marsh estuarine systems simulation*. Belle W. Baruch Library in Marine Science Number 8, University of South Carolina Press, Columbia, S.C.
- Eggler, W.A., A. Ekker, R.T. Gregg, E. Haden, A. Novak, R.P. Waldron, and H.B. Williams. 1961. Louisiana coastal marsh ecology. La. State Univ. Coastal Stud. Inst. Baton Rouge, Tech. Rep. No. 14. 273 pp.
- Engler, R.M., and W.H. Patrick. 1974. Nitrate removal from floodwater overlaying flooded soils and sediments. *J. Environ. Qual.* 2:409-413.
- Environmental Protection Agency. 1971. Storm water management model. U.S. EPA Water Pollution Control Res. Ser., 11024DOC07/71. 352 pp.
- Environmental Protection Agency. 1977. Preventative approaches to stormwater management. EPA 440/9-77-001.
- Ensminger, A.B., and L.G. Nichols. 1957. Hurricane damage to Rockefeller Refuge. *Proc. Southeast. Assoc. Game Fish Comm. Conf.* 11:52-56.
- Farfante, I.P. 1969. Western Atlantic shrimps of the genus *Penaeus*. U.S. Fish Wildl. Serv. *Fish. Bull.* 67(3): 462-591.
- Farrell, D.H. 1979. Benthic molluscan and crustacean communities in Louisiana. Pages 401-436 in C.H. Ward, M.E. Bender, and D.J. Reish, eds. *The offshore ecology investigation, effects of oil drilling and production in a coastal environment*. Rice Univ. Studies 65(4&5):1-589.
- Feijtel, T.C. 1986. Biogeochemical cycling of metals in Barataria Basin. M.S. Thesis. Louisiana State University, Baton Rouge. 279 pp.
- Feijtel, T.C., R.D. DeLaune, and W.H. Patrick, Jr. 1983. Carbon flow in coastal Louisiana. *Mar. Ecol. Prog. Ser.* 24:255-260.
- Fisk, H.N. 1955. Sand facies of recent Mississippi delta deposits. Section 1, pages 377-398 in *Proc. 4th World Petroleum Congress, Rome, Italy*.
- Fisk, H.N., and E. McFarland, Jr. 1955. Late quaternary deltaic deposits of the Mississippi River, local sedimentation and basin tectonics.

- Pages 279-302 in A Poldervaart, ed. Crust of the earth. Geol. Soc. Am. Spec. Pap. 62.
- Forman, W. 1968. The ecology of the Cyprinodontidae (Pisces) of Grand Terre Island, Louisiana. M.S. Thesis. Louisiana State University, Baton Rouge. 115 pp.
- Friloux, J.J. 1971. Petroleum wastes as a water pollution problem in the lower Mississippi River. Senate Subcommittee on Air and Water Pollution, New Orleans.
- Fritts, T.H., A.B. Irvine, R.D. Jennings, L.A. Collum, W. Hoffman, and M.A. McGehee. 1983. Turtles, birds, and mammals in the northern Gulf of Mexico and nearby Atlantic waters. U.S. Fish Wildl. Serv. Biol. Serv. Program FWS/OBS-82/65. 455 pp.
- Fuller, D.A. 1980. The habitats, distribution, and incidental capture of sea turtles in the Gulf of Mexico. In R.E. Condrey, tech. dir. Fishery management plan for the shrimp fishery for the Gulf of Mexico. Fed. Reg. 45(218):74100-74309.
- Gael, B.T. 1980. Computation of drift patterns in Lake Pontchartrain, Louisiana. Pages 39-56 in J.H. Stone, ed. Environmental analysis of Lake Pontchartrain, Louisiana, its surrounding wetlands, and selected land uses. Vol. 1. U.S. Army Engineer District, New Orleans. Contract No. DACW29-77-C-0253.
- Gael, B.T., and C.S. Hopkinson. 1979. Drainage density, land use, and eutrophication in Barataria Basin, Louisiana. Pages 147-163 in J.W. Day, Jr., D.D. Culley, Jr., R.E. Turner, and A.J. Mumphrey, eds. Proceedings Third Coastal Marsh and Estuary Management Symposium. Louisiana State University Division of Continuing Education, Baton Rouge.
- Gagliano, S.M. 1973. Canals, dredging, and land reclamation in the Louisiana coastal zone. Hydrologic and Geologic Studies of the Louisiana Coastal Zone, Rep. No. 14. Coastal Resources Unit, Center for Wetland Resources, Louisiana State University, Baton Rouge. 104 pp.
- Gagliano, S.M. 1981. Marsh deterioration and land loss in the deltaic plain of Louisiana. Special report to Louisiana Department of Natural Resources and Louisiana Wildlife and Fisheries Committee, New Orleans, La. Coastal Environment, Inc., Baton Rouge. 13 pp.
- Gagliano, S.M., P.P. Light, and R.E. Becker. 1971. Controlled diversion in the Mississippi River Delta system: an approach to environmental management. Hydrol. Geol. Stud. La. Coastal Zone, Rep. No. 8. Coastal Resources Unit, Center for Wetland Resources, Louisiana State University, Baton Rouge. 134 pp.
- Gagliano, S.M., K.J. Meyer-Arendt, and K.M. Wicker. 1981. Land loss in the Mississippi River Deltaic Plain. Trans. Gulf Coast Assoc. Geol. Soc. 31:295-300.
- Gallagher, J.L. 1975. Effect of an ammonium nitrate pulse on the growth and elemental composition of natural stands of *Spartina alterniflora* and *Juncus roemerianus*. Am. J. Bot. 62:644-648.
- Gauthreaux, S.A., Jr. 1971. A radar and direct visual study of passerine migration in southern Louisiana. Auk 88(2):343-365.
- Giles, L.S., and V. Childs. 1949. Alligator management on the Sabine National Wildlife Refuge. J. Wildl. Manage. 13(1):16-28.
- Gillespie, M.C. 1969. The polyhaline isopoda of the western Mississippi River Delta. Proc. La. Acad. Sci. 32:53-56.
- Gillespie, M.C. 1971. Analysis and treatment of zooplankton of estuarine waters of Louisiana. Pages 108-175 in Cooperative Gulf of Mexico estuarine inventory and study, Louisiana. Phase 4, Biology. Louisiana Wildlife and Fisheries Commission, New Orleans.
- Gillespie, M.C. 1978. Zooplankton analysis. Pages 27-80 in A study of Louisiana's major estuaries and adjacent offshore waters. La. Wildl. Fish. Comm. Tech. Bull. No. 27.
- Glasgow, L.L. and J. Bardwell. 1962. Pintail and teal foods in south Louisiana. Proc. Southeast. State Game Fish Comm. Conf. 16:175-184.

- Gonzalez, J.G. 1958. The copepods of the Mississippi delta region. M.S. Thesis. Texas A&M College, College Station.
- Gornitz, V., S. Lebedeff, and J. Hansen. 1982. Global sea trend in the past century. *Science* 215:1611-1614.
- Gosselink, J.G., C.L. Cordes, and J.W. Parsons. 1979. An ecological characterization study of the Chenier Plain coastal ecosystem of Louisiana and Texas. 3 vols. U.S. Fish Wildl. Serv. Biol. Serv. Program FWS/OBS-79/9 through 78/11.
- Guillory, V. 1982. An annotated checklist of the marine fish fauna of Grand Isle, Louisiana. *La. Dep. Wildl. Fish. Tech. Bull.* 35:1-13.
- Grace, S.F. 1932. The principal diurnal constituents of tidal motion in the Gulf of Mexico. *R. Astron. Soc. Mon. Not., Geophys. Suppl.* 3:70-83.
- Gunter, G. 1936. Studies of the destruction of marine fish by shrimp trawlers in Louisiana. *La. Conserv. Rev.* 5:18-24, 45-56.
- Gunter, G. 1938a. The relative numbers of species of marine fish on the Louisiana coast. *Am. Nat.* 72:77-83.
- Gunter, G. 1938b. Seasonal variations in abundance of certain estuarine and marine fishes in Louisiana with particular reference to life histories. *Ecol. Monogr.* 8:314-346.
- Gunter, G. 1961. Some relationships of estuarine organisms to salinity. *Limnol. Oceanogr.* 6:183-190.
- Gunter, G. 1967. Some relationships of estuaries to the fisheries of the Gulf of Mexico. Pages 621-638 in G.H. Lauff, ed. *Estuaries*. AAAS Publ. 83, Washington, D.C.
- Haedrich, R.L. 1983. Estuarine fishes. Pages 183-207 in B.H. Ketchum, ed. *Estuaries and enclosed seas*. *Ecosystems of the World* 26. Elsevier Sci. Publ. Co., New York.
- Hansen, K.L., E.G. Ruby, and R.L. Thompson. 1971. Trophic relations in the water hyacinth community. *Q. J. Fla. Acad. Sci.* 43(2):107.
- Happ, G., J.G. Gosselink, and J.W. Day, Jr. 1977. The seasonal distribution of organic carbon in a Louisiana estuary. *Estuarine Coastal Mar. Sci.* 5:695-705.
- Happ, G., V.R. Bennett, W.H. Burke III, W.H. Conner, N.J. Craig, R.E. Hinchee, J.H. Stone, and L.M. Bahr, Jr. 1976. Impacts of Outer Continental Shelf activities: Lafourche Parish, Louisiana. Louisiana State Planning Office, Coastal Resources Program, Baton Rouge.
- Hart, C.W., and S.L.H. Fuller. 1974. Population ecology of freshwater invertebrates. Academic Press, New York. 389 pp.
- Hatton, R.S. 1981. Aspects of marsh accretion and geochemistry: Barataria Basin, Louisiana. M.S. Thesis. Louisiana State University, Baton Rouge. 117 pp.
- Hatton, R.S., R.D. DeLaune, and W.H. Patrick, Jr. 1983. Sedimentation, accretion, and subsidence in marshes of Barataria Basin, Louisiana. *Limnol. Oceanogr.* 28:494-502.
- Hebrard, J. 1971. The nightly initiation of passerine migration in spring: a direct visual study. *Ibis* 113:8-18.
- Hicks, S.P. 1981. Long-term sea level variations for the United States through 1978. *Shore and Beach* 49:26-29.
- Ho, C.L., and B.B. Barrett. 1975. Distribution of nutrients in Louisiana's coastal waters influenced by the Mississippi River. *La. Wildl. Fish. Comm., New Orleans. Tech. Bull. No. 17.* 39 pp.
- Ho, C.L., and B.B. Barrett. 1977. Distribution of nutrients in Louisiana's coastal waters influenced by the Mississippi River. *Estuarine Coastal Mar. Sci.* 5:173-195.
- Ho, C.L., and J. Lane. 1973. Interstitial water composition in Barataria Bay (Louisiana) sediment. *Estuarine Coastal Mar. Sci.* 1:123-135.
- Hoover, R., T. Mason, F. McKay, and J. Frawmeni, Jr. 1975. Cancer by country: new resources of etiologic clues. *Science* 189:1005-1007.



- Hopkins, T.L. 1966. Plankton of the St. Andrew Bay System of Florida. *Publ. Estuarine Mar. Sci., Univ. Tex.* 11:12-64.
- Hopkinson, C.S. 1978. The relation of man and nature in Barataria Basin, Louisiana. Ph.D. Dissertation. La. State Univ., Baton Rouge. 236 pp.
- Hopkinson, C.S., and J.W. Day, Jr. 1977. A model of the Barataria Bay salt marsh ecosystem. Pages 235-266 in C.A.S. Hall and J.W. Day, Jr., eds. *Ecosystem modeling in theory and practice*. John Wiley and Sons, Inc., New York.
- Hopkinson, C.S., and J.W. Day, Jr. 1979. Aquatic productivity and water quality at the upland-estuary interface in Barataria Basin, Louisiana. Pages 291-314 in R. Livingston, ed. *Ecological processes in coastal and marine systems*. Plenum Press, New York.
- Hopkinson, C.S., and J.W. Day, Jr. 1980a. Modeling the relationship between development and storm water and nutrient runoff. *Environ. Manage.* 4:315-324.
- Hopkinson, C.S., and J.W. Day, Jr. 1980b. Modeling hydrology and eutrophication in a Louisiana swamp forest ecosystem. *Environ. Manage.* 4:325-335.
- Hopkinson, C.S., J.W. Day, Jr., and B.T. Gael. 1978. Respiration studies in a Louisiana salt marsh. *An. Centro Cienc. del Mar y Limnol. Univ. Nal. Auton. Mexico* 5:225-238.
- Hopkinson, C.S., J.G. Gosselink, and R.T. Parrondo. 1978. Aboveground production of seven marsh plant species in coastal Louisiana. *Ecology* 59:760-769.
- Hopkinson, C.S., J.G. Gosselink, and R.T. Parrondo. 1980. Production of coastal Louisiana marsh plants calculated from phenometric techniques. *Ecology* 61:1091-1098.
- Hopkinson, C.S., J.W. Day, Jr., and B.J. Kjerfve. 1985. Ecological significance of summer storms on shallow coastal lake and estuarine systems. *Contrib. Mar. Sci.* 28:69-77.
- Horton, R.E. 1945. Erosional development of streams and their drainage basins: hydrophysical approach to quantitative morphology. *Bull. Geol. Soc. Am.* 56:275-370.
- Howes, B., R. Howarth, J. Teal, and I. Valiela. 1981. Oxidation-reduction potentials in a salt marsh: spatial patterns and interactions with primary production. *Limnol. Oceanogr.* 26:350-360.
- Hunt, L.J. 1979. Use of dredged materials disposal in mitigation. Pages 502-507 in G.A. Swanson, tech. coord. *The mitigation symposium: a national workshop on mitigation losses of fish and wildlife habitat*. Rocky Mountain Forest and Range Experiment Station, Fort Collins, Colo. Gen. Tech. Rep. RM-65.
- Hutchinson, G.E. 1979. *An introduction to population ecology*. Yale University Press, New Haven. 260 pp.
- Jaworski, E. 1972. The blue crab fishery, Barataria estuary, Louisiana. La. State Univ., Baton Rouge. Sea Grant Publ. No. LSU-SG-72-01. 112 pp.
- Jemison, E.S., and R.H. Chabreck. 1962. Winter barn owl foods in a Louisiana coastal marsh. *Wilson Bull.* 74:95-96.
- Jensen, F. 1949. No title or text. A series of graphs showing oxygen and redox potential measurements in Barataria Bay, taken in 1948. Texas A&M Research Foundation, Project 9.
- Joanen, T., and L. McNease. 1982. Management of the alligator as a renewable resource in Louisiana. Louisiana Department of Wildlife and Fisheries, Grand Chenier, La. 6 pp.
- Johnson, W.B., and J.G. Gosselink. 1982. Wetland loss directly associated with canal dredging in the Louisiana coastal zone. Pages 60-72 in D.F. Boesch, ed. *Proceedings of a conference on coastal erosion and wetland modification in Louisiana: causes, consequences, and options*. U.S. Fish Wildl. Serv. Biol. Serv. Program FWS/OBS-82/59.
- Joseph, E.B. 1973. Analysis of a nursery ground. Pages 118-121 in A.L. Pacheco, ed.

- Proceedings of a workshop on egg, larval, and juvenile stages of fish in Atlantic coast estuaries. Natl. Mar. Fish. Ser. Tech. Publ. No. 1, Highlands, N.J. 338 pp.
- Keefe, C.W., and W.R. Boynton. 1973. Standing crops of salt marshes surrounding Chincoteague Bay, Maryland-Virginia. Chesapeake Sci. 14:117-123.
- Keller, C.E., J.A. Spendelow, and R.D. Greer. 1984. Atlas of wading bird and seabird nesting colonies in coastal Louisiana, Mississippi, and Alabama: 1983. U.S. Fish Wildl. Serv. FWS/OBS-84/13. 127 pp.
- Kelly, J.R., and S.W. Nixon. 1984. Experimental studies of the effect of organic deposition on the metabolism of a coastal marine bottom community. Mar. Ecol. Prog. Ser. 17:157-169.
- Kemp, G.P. 1978. Agricultural runoff and nutrient dynamics of a swamp forest in Louisiana. M.S. Thesis, Louisiana State University, Baton Rouge. 58 pp.
- Kemp, G.P., and J.W. Day, Jr. 1981. Floodwater nutrient processing in a Louisiana swamp forest receiving agricultural runoff. Louisiana Water Resources Research Institute, Louisiana State University, Baton Rouge. Rep. No. A-043-LA. 60 pp.
- Kemp, G.P., and J.W. Day, Jr. 1984. Nutrient dynamics in a Louisiana swamp receiving agricultural runoff. Pages 286-293 in K.C. Ewel and H.T. Odum, eds. Cypress swamps. University Presses of Florida, Gainesville.
- Kemp, G.P., W.H. Conner, and John W. Day, Jr. 1986. Effects of flooding on decomposition and nutrient cycling in a Louisiana swamp. Wetlands 5:35-51.
- Kirby, C.J., and J.G. Gosselink. 1976. Primary production in a Louisiana gulf coast *Spartina alterniflora* marsh. Ecology 57:1052-1059.
- Kjerfve, B. 1972. Circulation and salinity distribution in a marsh-lake system in coastal Louisiana. La. State Univ. Center for Wetland Resources, Publication No. LSU-SG-72-06. 54 pp.
- Kniffen, F.B. 1968. Louisiana: its land and people. La. State Univ. Press, Baton Rouge. 196 pp.
- Kolb, C.R., and J.R. Van Lopik. 1958. Geology of the Mississippi deltaic plain, southeastern Louisiana. U.S. Army Corps of Engineers, Waterways Experiment Station, Vicksburg, Miss. Tech. Rep. 3-483, 2 vols.
- Kritzler, H. 1979. Oil production and ecology of the littoral polychaeta of Timbalier Bay. Pages 473-490 in C.H. Ward, M.E. Bender, and D.J. Reisch, eds. The offshore ecology investigation, effects of oil drilling and production in a coastal environment. Rice Univ. Stud. 65(4&5):1-589.
- Krumbein, W.C., and E. Aberdeen. 1937. The sediments of Barataria Bay. J. Sediment Petrol. 7:3-17.
- Lantz, K. 1970. An ecological survey of the factors affecting fish production in a Louisiana natural lake and river. La. Wildl. Fish. Comm., New Orleans. Bull. No. 6. 92 pp.
- Levine, N.D. 1978. *Perkinsus* gen. n. and other new taxa in the protozoan phylum Apicomplexa. J. Parasitol. 64(3):549.
- Levine, S.J. 1980. Gut contents of forty-four Lake Pontchartrain fish species. Pages 899-994 in Stone, J.H., ed. Environmental analysis of Lake Pontchartrain, Louisiana, its surrounding wetlands, and selected land uses. U.S. Army Engineer District, New Orleans. Contract No. DACW29-77-C-0253.
- Lindall, W.N., Jr., and C.H. Saloman. 1977. Alteration and destruction of estuaries affecting fishery resources of the Gulf of Mexico. Mar. Fish. Rev. 39:1-7.
- Lindall, W.N., Jr., A. Manger, Jr., G.W. Thayer, and D.R. Ekberg. 1979. Estuarine habitat mitigation planning in the southeast. Pages 129-135 in G.A. Swanson, tech. coord. The mitigation symposium: a national workshop on mitigating losses of fish and wildlife habitat. Rocky Mountain Forest and Range Experiment Station, Fort Collins, Colo. General Tech. Rep. RM-65.

- Lindemann, R.L. 1942. The trophic-dynamic aspect of ecology. *Ecology* 23:399-418.
- Lindstedt, D.M. 1978. Effects of long term oil-recovery operations on macrobenthic communities near marsh-estuarine creek banks. M.S. Thesis, Louisiana State University, Baton Rouge. 67 pp.
- Linscombe, G., and T. O'Neil. 1982. The fur industry in Louisiana. La. Dep. Wildl. Fish., Baton Rouge. Publ. No. 106.
- Linscombe, G., N. Kinler, and V. Wright. 1984. Nutria population density and vegetative changes in brackish marsh in coastal Louisiana. Proceedings of the Worldwide Furbearer Conference, Frostburg, Maryland.
- Lisitzin, E., and J.G. Pattullo. 1961. The principal factors influencing the seasonal oscillation of sea level. *J. Geophysical Res.* 66(3): 845-852.
- Long, C. 1963. Mathematical formulas expressing faunal resemblance. *Trans. Kans. Acad. Sci.* 66(1): 138-140.
- Longley, W.L., R. Jackson, and B. Snyder. 1978. Managing oil and gas activities in coastal environments. U.S. Fish Wildl. Serv. Biol. Serv. Program FWS/OBS-78/54. 66 pp.
- Louisiana Department of Wildlife and Fisheries. (LDWF). 1983. Louisiana small game harvest report for 1982-1983. New Orleans, La.
- Louisiana Department of Wildlife and Fisheries. (LDWF). 1984. Annual midwinter waterfowl survey. Jan 3, 4, 5, 1984. Reported by C. Smith, R. Helm, M. Olinde, and D. Moreland. New Orleans, La.
- Lowery, G.H., Jr. 1945. Trans-gulf spring migration of birds and the coastal hiatus. *Wilson Bull.* 57:92-121.
- Lowery, G.H., Jr. 1974a. Louisiana birds. Louisiana State University Press, Baton Rouge. 651 pp.
- Lowery, G.H., Jr. 1974b. The mammals of Louisiana and its adjacent waters. Louisiana State University Press, Baton Rouge. 565 pp.
- Lynch, J.J., T. O'Neill, and D.W. Lay. 1947. Management significance of damage by geese and muskrats to gulf coast marshes. *J. Wildl. Manage.* 2(1):50-76.
- Mabie, D.A. 1976. Reptiles and amphibians. Appendix VI, Section 10 in J.G. Gosselink, R.R. Miller, M.A. Hood, and L.M. Bahr, eds. Louisiana Offshore Oil Port environmental baseline study. LOOP, Inc., New Orleans, La.
- Mackin, J.G. 1962. Oyster disease caused by Dermocystidium marinum and other microorganisms in Louisiana. *Publ. Inst. Mar. Sci. Univ. Texas* 7:132-229.
- Mackin, J.G., and S.H. Hopkins. 1962a. Studies on oysters in relation to the oil industry. *Publ. Inst. Mar. Sci. Univ. Tex.* 7:v-xi.
- Mackin, J.G., and S.H. Hopkins. 1962b. Studies on oyster mortality in relation to natural environments and to oil fields in Louisiana. *Publ. Inst. Mar. Sci. Univ. Tex.* 7:1-131.
- Mackin, J.G., and S.M. Ray. 1966. The taxonomic relationships of Dermocystidium marinum Mackin, Owen, and Collier. *J. Invertebr. Pathol.* 8:544-545.
- Mackin, J.G., and A.K. Sparks. 1962. A study of the effect on oysters of crude oil loss from a wild well. *Publ. Inst. Mar. Sci. Univ. Tex.* 7:230-261.
- Mackin, J.G., H.M. Owen, and A. Collier. 1950a. Preliminary note on the occurrence of a new protistan parasite, Dermocystidium marina n. sp. in Crassostrea virginica (Gmelin). *Science* 111:328-329.
- Mackin, J.G., B. Welch, and C. Kent. 1950b. A study of mortality of oysters of the Buras area of Louisiana. Texas A&M Research Foundation, Project 9.
- Mancil, E. 1972. A historical geography of industrial lumbering in Louisiana. Ph.D. Dissertation. Louisiana State University, Baton Rouge. 278 pp.
- Mann, K.H. 1982. Ecology of coastal waters: a systems approach. University of California Press, Berkeley. 322 pp.

- Marmer, H.A. 1948. The currents in Barataria Bay. Texas A&M Research Foundation, Project 9.
- Marmer, H.A. 1954. Tides and sea level in the Gulf of Mexico. Pages 101-118 *in* Gulf of Mexico, its origin, waters and marine life. U.S. Fish Wildl. Serv. Fishery Bull. 55.
- Mason, C.F., and R.J. Bryant. 1975. Periphyton production and grazing by chironomoids in Alderfen Broad, Norfolk. Freshwater Biol. 5:271-277.
- Mattoon, W.R. 1915. The southern cypress. USDA, Washington, D.C. Bull. No. 272. 74 pp.
- McGinnis, J.T., R.A. Ewing, C.A. Willingham, S.E. Rogers, D.H. Douglass, and D.L. Morrison. 1972. Final report on environmental aspects of gas pipelines in marshes. Battelle Inc., Columbus, Ohio. 96 pp.
- McNamara, S.J. 1978. Metabolism measurements of a flooded soil community in a Louisiana swamp forest. M.S. Thesis. Louisiana State University, Baton Rouge. 65 pp.
- Meade, R.H., and K.O. Emery. 1971. Sea level as affected by river runoff, eastern United States. Science 173:425-428.
- Mendelssohn, I.A. 1978. Eco-physiological aspects of the height forms of *Spartina alterniflora* in North Carolina: nitrogen nutrition and soil waterlogging. Ph.D. Dissertation. North Carolina State University, Raleigh. 142 pp.
- Mendelssohn, I.A. 1979. Nitrogen metabolism in the height forms of *Spartina alterniflora* in North Carolina. Ecology 60:574-584.
- Mendelssohn, I.A. 1982. Sand dune vegetation and stabilization in Louisiana. Pages 187-207 *in* D.F. Boesch, ed. Proceedings of a conference on land loss and wetland modifications in Louisiana: causes, consequences, and options. U.S. Fish Wildl. Serv. Biol. Serv. Program FWS/OBS-82/59.
- Mendelssohn, I.A., K.L. McKee, and W.H. Patrick, Jr. 1981. Oxygen deficiency in *Spartina alterniflora* roots: metabolic adaptation to anoxia. Science 214:439-441.
- Meo, M., J.W. Day, Jr., and T.B. Ford. 1975. Overland flow in the Louisiana coastal zone. La. State Univ. Center for Wetland Resources, Baton Rouge. Sea Grant Publ. No. LSU-T-75-04. 54 pp.
- Moore, D., H.A. Brusher, and L. Trent. 1970. Relative abundance, seasonal distribution and species composition of demersal fishes off Louisiana and Texas, 1962-1964. Contrib. Mar. Sci. 15:45-70.
- Moore, H.F. 1899. Report on the oyster beds of Louisiana. Pages 49-100 *in* Report of the Commissioner, U.S. Comm. Fish and Fisheries for 1898.
- Morgan, J.P. 1967. Ephemeral estuaries of the deltaic environment. Pages 115-120 *in* G. Lauff, ed. Estuaries. AAAS Publ. No. 83.
- Morgan, J.P. 1972. Impact of subsidence and erosion on Louisiana coastal marshes and estuaries. Pages 217-233 *in* R.H. Chabreck, ed. Proceedings of the second coastal marsh and estuarine management symposium. La. State Univ. Division of Continuing Education, Baton Rouge.
- Morgan, J.P., and P.B. Larimore. 1957. Changes in the Louisiana shoreline. Trans. Gulf Coast Assoc. Geol. Soc. 7:303-310.
- Muller, R.A. 1977. A synoptic climatology for environmental baseline analysis: New Orleans. J. Appl. Meteorol. 16(1):20-33.
- Mumphrey, A.J., J.S. Brooks, T.D. Fox, C.B. Fromberg, R.J. Marak, and J.O. Wilkinson. 1978. The value of wetlands in the Barataria Basin. Urban Studies Institute, University of New Orleans. 151 pp.
- National Marine Fisheries Service. 1979. Guidelines and criteria for proposed wetland alterations in the southeast region.
- Negus, N.C., E. Gould, and R.K. Chapman. 1961. Ecology of the rice rat, *Orzomyz palustris*, on Breton Island, Gulf of Mexico. Tulane Stud. Zool. Bot. 8:93-123.
- Nixon, S.W. 1981. Remineralization and nutrient cycling in coastal marine ecosystems. Pages

- 111-138 *in* B.J. Neilson and L.W. Cronin, eds. Estuaries and nutrients. Humana Press, Clifton, N.J.
- Nixon, S.W., and C.A. Oviatt. 1973. Ecology of a New England salt marsh. *Ecol. Monogr.* 43:463-498.
- Norgress, R.E. 1947. The history of the cypress lumber industry in Louisiana. *La. Hist. Q.* 30:979-1059.
- Odum, H.T. 1957. Primary production measurements in eleven Florida springs and a marine turtle grass community. *Limnol. Oceanogr.* 2:85-97.
- Odum, H.T. 1983. Systems ecology. Wiley and Sons, New York. 644 pp.
- Ogren, L.H. 1977. Survey and reconnaissance of sea turtles in the northern Gulf of Mexico. National Marine Fishery Service, Panama City, Fla. 8 pp. (mimeo).
- O'Hara, J. 1967. Invertebrates found in water hyacinth mats. *Q. J. Fla. Acad. Sci.* 30(1):73.
- O'Neil, T. 1949. The muskrat of Louisiana. Louisiana Department of Wildlife and Fisheries, New Orleans. Tech. Rep. 159 pp.
- Oversheet, R.M. and R.W. Heard. 1978. Food of the atlantic croaker, *Micropogonias undulatus*, from Mississippi Sound and the Gulf of Mexico. *Gulf Res. Rep.* 6:145-152.
- Page, T., R. Harris, and S.S. Epstine. 1976. Drinking water and cancer mortality in Louisiana. *Science* 193:55-57.
- Paille, R.F. 1980. Production of three populations of red swamp crawfish, *Procambrus charkii*, in southeast Louisiana. M.S. Thesis. Louisiana State University, Baton Rouge. 41 pp.
- Palmisano, A.W. 1970. Plant community-soil relationships in Louisiana coastal marshes. Ph.D. Dissertation. Louisiana State University, Baton Rouge. 143 pp.
- Palmisano, A.W. 1972. The distribution and abundance of muskrats (*Ondatra zibethicus*) in relation to vegetative types in Louisiana coastal marshes. Southeast. Assoc. Game Fish Comm. Conf. 26:160-176.
- Palmisano, A.W. 1973. Habitat preference of waterfowl and fur animals in northern gulf coast marshes. Pages 163-190 *in* R.H. Chabreck, ed. Coastal marsh and estuary management symposium. La. State Univ. Division of Continuing Education, Baton Rouge.
- Patrick, W.H., Jr., and R.D. Delaune. 1976. Nitrogen and phosphorous utilization by *S. alterniflora* in a salt marsh in Barataria Bay, Louisiana. *Estuarine Coastal Mar. Sci.* 4:59-64.
- Paulus, S.L. 1982. Feeding ecology of gadwalls in Louisiana in winter. *J. Wildl. Manage.* 46:71-79.
- Payne, F.T. 1912. Chief Surveyor's Report. Report of the Board of Commissioners for the Protection of Birds, Game, and Fish, State of Louisiana, 1912. Pages 22-29.
- Payne, F.T. 1920. Report of the Division of Water Bottoms. Pages 131-153 *in* Fourth Biennial Report, Department of Conservation, State of Louisiana, 1918-1920.
- Payonk, P.M. 1975. The response of three species of marsh macrophytes to artificial enrichment at Dulac, Louisiana. M.S. Thesis. Louisiana State University, Baton Rouge. 122 pp.
- Penfound, W.T. 1952. Southern swamps and marshes. *Bot. Rev.* 18:413-446.
- Penfound, W.T. and E. Hathaway. 1938. Plant communities in the marshlands of southeastern Louisiana. *Ecol. Monogr.* 8:1-56.
- Pennak, R.W. 1978. Fresh-water invertebrates of the United States. 2nd ed. Wiley and Sons, Inc., New York. 803 pp.
- Perkins, F.O. 1969. Ultrastructure of vegetative stages in *Labyrinthomyxa marina* (= *Dermocystidium marinium*), a commercially significant oyster pathogen. *J. Invertebr. Pathol.* 13:199-222.
- Perret, W.S., B.B. Barrett, W.R. Latapie, J.F. Pollard, W.R. Mock, G.B. Adkins, W.J. Gaidry,

- and C.J. White. 1971. Cooperative Gulf of Mexico estuarine inventory and study, Louisiana, Phase 1, area description. Louisiana Wildlife and Fisheries Commission, New Orleans. Pages 31-175.
- Perry, A. 1979. Fish of Timbalier Bay and offshore Louisiana environments collected by trawling. Rice Univ. Stud. 65(4/5):537-545.
- Perry, H.M., and J.Y. Christmas. 1973. Estuarine zooplankton, Mississippi. Pages 201-254 in J.Y. Christmas, ed. Cooperative Gulf of Mexico estuarine inventory and study. Mississippi Gulf Coast Research Laboratory, Ocean Springs.
- Peters, D. 1968. A study of relationships between zooplankton abundance and selected environmental variables in the Pamlico River Estuary of eastern North Carolina. M.S. Thesis. North Carolina State University, Raleigh. 38 pp.
- Peterson, C.H. 1979. Predation, competitive exclusion, and diversity in the soft-sediment communities of estuaries and lagoons. Pages 233-264 in Livingston, R.J., ed. Ecological processes in coastal and marine systems. Plenum Press, New York.
- Peterson, T. 1980. A field guide to the birds. Houghton Mifflin Co., Boston. 230 pp.
- Pezeshki, S.R., R.D. DeLaune, and W.H. Patrick, Jr. In press. Stomatol and photosynthetic response of Spartina patens to increasing levels of salinity in marshes of the rapidly subsiding Mississippi River Deltaic Plain. Estuarine Coastal Shelf Sci.
- Philomena, A.L. 1983. The distribution of macrobenthos in Barataria Basin, Louisiana. M.S. Thesis. Louisiana State University, Baton Rouge. 140 pp.
- Platt, H.M. 1981. Meiofauna dynamics and the origin of the metazoa. Pages 207-216 in P.L. Forey, ed. The evolving biosphere. British Museum (Natural History), Cambridge University Press.
- Portnoy, J.W. 1977. Nesting colonies of seabirds and wading birds - coastal Louisiana, Mississippi, and Alabama. U.S. Fish Wildl. Serv. Biol. Serv. Program FWS/OBS-77/07. 126 pp.
- Rabalais, N., M. Dagg, and D. Boesch. 1985. Nationwide review of oxygen depletion and eutrophication in estuarine and coastal waters: Gulf of Mexico (Alabama, Mississippi, Louisiana, and Texas). Ocean Assessments Div., Natl. Oceanographic and Atmospheric Administration. 60 pp.
- Remane, A. 1934. Die Brackwasserfauna. Verh. Dtsch. Zool. Ges. 36:36-74.
- Remane, A., and C. Schlieper. 1971. Biology of brackish water. Wiley and Sons, Inc., New York. 372 pp.
- Rogers, B. 1979. The spatial and temporal distribution of Atlantic croaker, Micropogon undulatus, and spot, Leiostomus xanthurus, in the upper drainage basin of Barataria Bay, Louisiana. M.S. Thesis. Louisiana State University, Baton Rouge. 96 pp.
- Rogers, R.M. 1970. Marine meiobenthic organisms in a Louisiana marsh. M.S. Thesis. Louisiana State University, Baton Rouge. 83 pp.
- Rohlich, G.A. 1969. Eutrophication: causes, consequences, correctives. National Academy of Science, Washington, D.C.
- Roper, C.F.E., M.J. Sweeney, and C.E. Nauen. 1984. FAO species catalogue. Vol. 3: Cephalopods of the world. An annotated and illustrated catalogue of species of interest to fisheries. FAO Fish. Synop. 125(3):1-277.
- Ruebsamen, R. 1972. Some ecological aspects of the fish fauna of a Louisiana intertidal pond system. M.S. Thesis. Louisiana State University, Baton Rouge. 80 pp.
- Russell, R.J. 1936. Physiography of the lower Mississippi River delta. La. Dep. Conserv. Bull. Geol. Surv. 8:2-199.
- Ruttner, F. 1968. Fundamentals of limnology. Trans. by D.G. Frey and F.E.J. Frey, Univ. Toronto Press, Canada. 295 pp.

- Sabins, D.S., and F.M. Truesdale. 1974. Diel and seasonal occurrence of immature fishes in a Louisiana tidal pass. Proc. Southeast. Assoc. Game Fish Comm. Conf. 28:161-171.
- Sanders, R. 1959. Climates of the States--Louisiana. U.S. Weather Bureau, Washington, D.C.
- Sanders, R. 1978. Climates of the states--Louisiana. U.S. Weather Bureau, Washington, D.C.
- Sasser, C.E. 1977. Distribution of vegetation in Louisiana coastal marshes as response to tidal flooding. M.S. Thesis. Louisiana State University, Baton Rouge. 40 pp.
- Sasser, C.E., and J.G. Gosselink. 1984. Vegetation and primary production in a floating freshwater marsh in Louisiana. Aquat. Bot.. 20:245-255.
- Sasser, C.E., G.W. Peterson, R.K. Abernathy, and J. Gosselink. 1983. 1982 Annual Report, Environmental Monitoring Program, Louisiana Offshore Oil Port Pipeline. Louisiana State University, Center for Wetland Resources, Baton Rouge. 231 pp.
- Sasser, C.E., G.W. Peterson, R.K. Abernathy, and J.G. Gosselink. 1984. 1983 Annual Report, Environmental Monitoring Program, Louisiana Offshore Oil Port Pipeline. Louisiana State University, Center for Wetland Resources, Baton Rouge. 207 pp.
- Scaife, W.W., R.E. Turner, and R. Costanza. 1983. Coastal Louisiana recent land loss and canal impacts. Environ. Manage. 7:433-442.
- Schelske, C.L., and E.P. Odum. 1961. Mechanisms maintaining high productivity in Georgia estuaries. Proc. Gulf Caribb. Fish. Inst. 14:75-80.
- Schenker, J.M., and J.M. Dean. 1979. The utilization of an intertidal salt marsh creek by larval and juvenile fishes: abundance, diversity, and temporal variation. Estuaries 2:154-163.
- Seaton, A.M. 1979. Nutrient chemistry in the Barataria Basin: a multivariate approach. M.S. Thesis. Louisiana State University, Baton Rouge. 124 pp.
- Seaton, A.M., and J.W. Day, Jr. 1979. The development of a trophic state index for the quantification of eutrophication in the Barataria Basin. Pages 113-125 in J.W. Day, Jr., D.D. Culley, Jr., R.E. Turner, and A.J. Mumphy, Jr., eds. Proceedings third coastal marsh and estuary management symposium, La. State Univ., Division of Continuing Education, Baton Rouge.
- Shannon, E.E., and P.L. Brezonik. 1972. Relationship between lake trophic state and nitrogen and phosphorus loading rates. Environ. Sci. Tech. 6:719-725.
- Sharp, H.F., Jr. 1967. Food ecology of the rice rat *Oryzomys palustris* in a Georgia salt marsh. J. Mammal. 48:557-563.
- Shiflet, T. 1963. Major ecological factors controlling plant communities in Louisiana marshes. J. Range Manage. 16:231-234.
- Sikora, W.B., and J.P. Sikora. 1985. Benthos. Pages 3.1-3.77 in An evolution of backfilling canals as a means of mitigating the environmental impact of canals in south Louisiana. Final Report Phase 3 to the Coastal Zone Management Section, Department of Natural Resources, State of Louisiana.
- Simmons, E.G. 1957. An ecological survey of the upper Laguna Madre of Texas. Publ. Inst. Mar. Sci. Univ. Tex. 4(2):156-200.
- Simoneaux, L.F. 1979. The distribution of menhaden, genus *Brevoortia*, with respect to salinity in the upper drainage basin of Barataria Bay, Louisiana. M.S. Thesis. Louisiana State University, Baton Rouge. 96 pp.
- Sklar, F.H. 1976. Primary productivity in the Mississippi Delta Bight near a shallow bay estuarine system in Louisiana. M.S. Thesis. Louisiana State University, Baton Rouge. 120 pp.
- Sklar, F.H. 1983. Water budget, benthological characterization, and simulation of aquatic material flows in a Louisiana freshwater swamp.

- Ph.D. Dissertation. Louisiana State University, Baton Rouge. 280 pp.
- Sklar, F.H., and W.H. Conner. 1979. Effects of altered hydrology on primary production and aquatic animal populations in a Louisiana swamp forest. Pages 191-210 in J.W. Day, Jr., D.D. Culley, Jr., R.E. Turner, and A.J. Mumphy, Jr., eds. Proceedings third coastal marsh and estuary management symposium, La. State Univ. Division of Continuing Education, Baton Rouge.
- Sklar, F.H., and W.H. Conner. 1983. Swamp forest communities and their relation to hydrology: the impacts of artificial canals. Pages 245-272 in R.J. Varnell, ed. Proceedings of the water quality and wetland management conference, New Orleans, La.
- Sklar, F.H., and R.E. Turner. 1981. Characteristics of phytoplankton production off Barataria Bay in an area influenced by the Mississippi River. *Contrib. Mar. Sci.* 24:93-106.
- Sklar, F.H., R. Costanza, J.W. Day, Jr., and W.H. Conner. 1983. Dynamic simulation of aquatic material flows in an impounded swamp habitat in the Barataria Basin, Louisiana. Pages 741-750 in W.K. Lauenroth, G.V. Skogerboe, and M. Flug, eds. Analysis of ecological systems: state-of-the-art of ecological modeling. Elsevier Scientific Publishing Co., Amsterdam.
- Sklar, F.H., R. Costanza, and J.W. Day, Jr. 1984. The conceptualization phase of wetland model development. In SCOPE/UNEP Proceedings of the International Conference on Freshwater Wetlands and Shallow Water Bodies, Tallin, USSR, 8/3/83.
- Smalley, A.E. 1958. The role of two invertebrate populations, *Littorina irrorata* and *Orchelimum fissicinum*, in the energy flow of a salt marsh ecosystem. Ph.D. Dissertation. University of Georgia, Athens. 126 pp.
- Smith, C.J., and R.D. DeLaune. 1983. Nitrogen loss from freshwater and saline estuarine sediments. *J. Environ. Qual.* 12(4):514-518.
- Smith, C.J. and R.D. DeLaune. 1985. Recovery of added  $^{15}\text{N}$  - labelled Ammonium-N from Louisiana gulf coast estuarine sediment. *Estuarine Coastal Shelf Sci.* 21:225-233.
- Smith, C.J., R.D. DeLaune, and W.H. Patrick, Jr. 1983. Carbon dioxide emission and carbon accumulation in coastal wetlands. *Estuarine Coastal Mar. Sci.* 17:21-29.
- Smith, D.A. 1979. Documentation of the use of brackish water estuarine zone as a nursery ground by Penaeid shrimp. M.S. Thesis. Louisiana State University, Baton Rouge. 91 pp.
- Smith, W.G. 1970. *Spartina* "die-back" in Louisiana marshlands. *La. State Univ. Coastal Stud. Bull. No.* 5:89-96.
- St. Amant, L.S. 1971. Impacts of oil on the gulf coast. *Trans. North Am. Wildl. Conf.* 36:206-219.
- St. Amant, L.S. 1972. The petroleum industry as it affects marine and estuarine ecology. *J. Pet. Tech.* 4:385-392.
- Stern, D.H., and M.S. Stern. 1969. Physical, chemical, bacterial, and plankton dynamics of Lake Pontchartrain, Louisiana. Louisiana Water Resources Research Institute, Tech. Rep. No. 4. Louisiana State University, Baton Rouge. 60 pp.
- Stitch, H.F., A.B. Acton, and B.P. Dunn. 1976. Carcinogens in estuaries, their monitoring as possible hazards to man in environmental pollution and carcinogenic risk. INSERM Symposia Series. Vol. 52. Int. Agency Cancer Res. Publ. No. 13.
- Stone, J.H. 1972. Preliminary assessment of the environmental impact of a superport on the southeastern coastal area of Louisiana. *La. Superport Stud. - Rep. 2.* Louisiana State University, Center for Wetland Resources, Baton Rouge.
- Stone, J.H., and G. McHugh. 1979. Hydrologic effects of canals in coastal Louisiana via computer simulation. Pages 339-346 in Proceedings of the summer computer simulation conference. Toronto, Canada. AFIPS Press, N. J.



- Stone, J.H., N.A. Drummond, L.L. Cook, E.C. Theriot, and D.M. Lindstedt. 1980. The distribution and abundance of plankton of Lake Pontchartrain, Louisiana, 1978. Pages 437-590 in J.H. Stone, ed. Environmental analysis of Lake Pontchartrain, Louisiana, its surrounding wetlands, and selected land uses. U.S. Army Engineer District, New Orleans, Contract No. DACW29-77-C-0253.
- Stow, C.A., R.D. DeLaune, and W.H. Patrick, Jr. 1985. Nutrient fluxes in a eutrophic coastal Louisiana freshwater lake. *Environ. Manage.* 9(3):243-252.
- Stowe, W.C. 1972. Community structure and production of the epiphytic algae in the Barataria Bay area of Louisiana. Ph.D. Dissertation. Louisiana State University, Baton Rouge. 85 pp.
- Stowe, W.C. 1980. Vertical distribution of epiphytic *Denticula subtilis* Grun. *Trans. Am. Microsc. Soc.* 99:323-328.
- Stowe, W.C. 1982. Diatoms epiphytic on the emergent grass *Spartina alterniflora* in a Louisiana salt marsh. *Trans. Am. Microsc. Soc.* 101:162-173.
- Sturges, W., and J.P. Blaha. 1976. A western boundary current in the Gulf of Mexico. *Science* 192:367-369.
- Sullivan, M.L., and F.C. Daiber. 1974. Response in production of cord grass, *Spartina alterniflora*, to inorganic nitrogen and phosphorous fertilizer. *Chesapeake Sci.* 15:121-123.
- Swanson, R.L., and C.I. Thurlow. 1973. Recent subsidence rates along the Texas and Louisiana coasts as determined from tide measurements. *J. Geophys. Res.* 78(15):2665-2671.
- Swenson, E.L. 1982. A report on the Catfish Lake, Louisiana, backfilling study. La. State Univ. Center for Wetland Resources, Baton Rouge, Publ. No. LSU-CEL-82-25. 44 pp.
- Thomas, J.D. 1975. Gammarid amphipods of the Barataria Bay, Louisiana region. M.S. Thesis. Louisiana State University, Baton Rouge. 32 pp.
- Thomas, J.D. 1976. Benthos. Pages VI.6-1 - VI.6-32 in J.G. Gosselink, R.R. Miller, M. Hood, and L.M. Bahr, Jr., eds. Louisiana Offshore Oil Port: environmental baseline study. Vol. 3, Appendix 6. Louisiana Offshore Oil Port, Inc., New Orleans, La.
- Thomas, J.D., and R.W. Heard. 1979. A new species of *Cerapus* Say, 1817 (Crustacea: Amphipoda) from the northern Gulf of Mexico, with notes on its ecology. *Proc. Biol. Soc. Wash.* 92:98-105.
- Thompson, B.A., and L. Deegan. 1983. The Atchafalaya River Delta: a "new" fish nursery, with recommendations for management. Pages 217-239 in F. Webb, ed. Proceedings 10th Annu. Conf. Wetland Restoration and Creation. Hillsborough Community College, Tampa, Fla.
- Thornthwaite, C.W. 1948. An approach toward a rational classification of climate. *Geogr. Rev.* 38:55-94.
- Tinkle, D.W. 1959. Observations of reptiles and amphibians in a Louisiana swamp. *Am. Midl. Nat.* 62:189-205.
- Turner, R.E. 1977. Intertidal vegetation and commercial yields of penaeid shrimp. *Trans. Am. Fish. Soc.* 106:411-416.
- Turner, R.E. 1979. Louisiana's coastal fisheries and changing environmental conditions. Pages 363-373 in J.W. Day, Jr., D.D. Culley, Jr., R.E. Turner, and A.J. Mumphrey, Jr., eds. Proceedings Third Coastal Marsh and Estuary Management Symposium, Louisiana State University, Division of Continuing Education, Baton Rouge.
- Turner, R.E. 1982. Wetland losses and coastal fisheries: an enigmatic and economically significant dependency. Pages 112-120 in D.F. Boesch, ed. Proceedings of the Conference on Coastal Erosion and Wetland Modification in Louisiana: Causes, Consequences, and Options. U.S. Fish Wildl. Serv. Biol. Serv. Program FWS/OBS-82/59. 256 pp.

- Turner, R.E., and J.G. Gosselink. 1975. A note on standing crops of *Spartina alterniflora* in Florida and Texas. *Contrib. Mar. Sci.* 19:113-118.
- Turner, R.E., R. Costanza, and W.W. Scaife. 1982. Canals and wetland erosion rates in coastal Louisiana. Pages 73-84 in D.F. Boesch, ed. *Proceedings Conference on Coastal Erosion and Wetland Modification in Louisiana: Causes, Consequences, and Options*. U.S. Fish Wildl. Serv. Biol. Serv. Program FWS/OBS-82/59.
- Tyler, A. 1971. Periodic and resident components in communities of Atlantic fishes. *J. Fish. Res. Board Can.* 28(7):935-946.
- U.S. Army Corps of Engineers. 1980. New Orleans - Baton Rouge metropolitan water resources study. U.S. Army Engineer District, New Orleans.
- U.S. Army Corps of Engineers. 1984. Louisiana coastal area, Louisiana: freshwater diversion to Barataria and Breton Sound basins. Draft Environmental Impact, New Orleans District. 3 vols.
- Valentine, J.M., J.R. Walther, K.M. McCartney, and L.M. Ivy. 1972. Alligator diets on the Sabine National Wildlife Refuge, Louisiana. *J. Wildl. Manage.* 36(3):809-815.
- Valiela, I. and J.M. Teal. 1974. Nutrient limitation in salt marsh vegetation. Pages 547-563 in R.J. Reimhold and W.H. Queen, eds. *Ecology of halophytes*. Academic Press, New York.
- Van der Stock, J.P. 1897. Wind, weather, currents, tides, and tidal streams on the East Indian Archipelago. Batavia (obtained from Division of Tides and Currents, U.S. Coast and Geodetic Survey).
- Van Sickle, V.R., B.B. Barrett, L.J. Gulick, and T.B. Ford. 1976. Barataria Basin: salinity changes and oyster distribution. Center for Wetland Resources, La. State Univ., Baton Rouge. Sea Grant Publ. LSU-T-76-002 and La. Dep. Wildl. Fish. Tech. Bull. 20:1-22.
- Vollenweider, R.A. 1968. Scientific fundamentals of the eutrophication of lake and flowing waters with particular reference to nitrogen and phosphorous as factors in eutrophication. Organization for Economic Cooperation and Development, Paris, France, Tech. Rep. DAS/CSI/68.27. 250 pp.
- Voors, A.W., W.D. Johnson, S.H. Steele, and H. Rothschild. 1978. Relationship between respiratory cancer and wetlands residency in Louisiana. *Arch. Environ. Health*, May/June:124-149
- Wagner, P.R. 1970. An annotated list of the crabs of the Barataria Bay area. Class report submitted for Marine Sciences class: Coastal Swamps and Marshes, Louisiana State University, Baton Rouge.
- Wagner, P.R. 1973. Seasonal biomass, abundance, and distribution of estuarine dependant fishes in the Caminada Bay system of Louisiana. Ph.D. Dissertation. Louisiana State University, Baton Rouge. 193 pp.
- Waller, R. 1979. Pelagic, epibenthic, and infaunal invertebrates of Timbalier Bay and offshore environment. *Rice Univ. Stud.* 65(4/5):529-536.
- Wang, F.C. In press. Effects of levee extension on marsh flooding. *J. Water Resour. Planning Manage. Am. Soc. Civil Eng.*
- Wax, C.L. 1977. An analysis of the relationship between water level fluctuations and climate of coastal Louisiana. Ph.D. Dissertation. Louisiana State University, Baton Rouge. 103 pp.
- Wax, C.L., M.J. Borgengasser, and R.A. Muller. 1978. Barataria Basin: synoptic weather types and environmental responses. Center for Wetland Resources, La. State Univ., Baton Rouge. Sea Grant Publ. LSU-T-78-001.
- Weinstein, M.P. 1979. Shallow marsh habitats as primary nurseries for fish and shellfish, Cape Fear River, North Carolina. U.S. Natl. Mar. Fish. Serv. Fish. Bull. 77:339-357.
- Wells, F.C. 1980. Hydrology and water quality of the lower Mississippi River. Louisiana Department of Transportation and Development, Baton Rouge. Water Resour. Tech. Rep. No. 21.

- Wetzel, R.G. 1975. *Limnology*. W.B. Saunders Company, Philadelphia, Penn. 743 pp.
- Whigham, D.F., J. McCormick, R.E. Good, and R.L. Simpson. 1978. Biomass and primary production in freshwater tidal wetlands of the middle Atlantic coast. Pages 3-20 in R.E. Good, D.F. Whigham, and R.L. Simpson, eds. *Freshwater wetlands: ecological processes and management potential*. Academic Press, New York.
- Whittaker, R. 1971. Seasonal variations of steric and recorded sea level of the Gulf of Mexico. Texas A&M University, College Station, Tex. Ref. 71-14T.
- Whitlatch, R.B. 1981. Animal-sediment relationships in intertidal marine benthic habitats: some determinants of deposit-feeding species diversity. *J. Exp. Mar. Biol. Ecol.* 53:31.
- Wicker, K.M. 1980. Mississippi Deltaic Plain region habitat mapping study. 464 maps. U.S. Fish Wildl. Serv. Biol. Serv. Program FWS/OBS-79/07.
- Wiens, J.A. 1977. On competition and variable environments. *Am. Sci.* 65:590.
- Wilhm, J.L., and T.C. Dorris. 1966. Species diversity of benthic macroinvertebrates in a stream receiving domestic and oil refinery effluents. *Am. Midl. Nat.* 76:427-449.
- Wisner, W. 1960. Benthic studies in Buzzard's Bay. 2. The meiofauna. *Limnol. Oceanogr.* 5:121-137.
- Witzig, A.S., and J.W. Day, Jr. 1983a. A multivariate approach to the investigation of nutrient interactions in the Barataria Basin, Louisiana. Louisiana Water Resources Research Institute, Louisiana State University, Baton Rouge. 36 pp.
- Witzig, A.S., and J.W. Day, Jr. 1983b. A trophic state index for the Louisiana coastal zone. Louisiana Water Resources Research Institute, Louisiana State University, Baton Rouge. 34 pp.
- Wolverton, B.C., R.M. Barlow, and R.C. McDonald. 1975. Application of vascular aquatic plants for pollution removal, energy, and food production in a biological system. National Space Technology Laboratories, Bay St. Louis, Miss. NASA Tech. Memo. TM-X-72726. 15 pp.
- Woodmansee, A.A. 1958. The seasonal distribution of the zooplankton of Chicken Key in Biscayne Bay, Florida. *Ecology* 39(2):247-262.
- Zeringue, F.J. 1980. An ecological characterization of the Lac des Allemands Basin. M.S. Thesis. Louisiana State University, Baton Rouge. 100 pp.
- Ziser, S.W. 1978. Seasonal variations in water chemistry and diversity of the phytophilic macroinvertebrates of three swamp communities in southeastern Louisiana. *Southwest. Nat.* 23:545-562.

50272-101

<b>REPORT DOCUMENTATION PAGE</b>	<b>1. REPORT NO.</b> Biological Report 85(7.13)	<b>2.</b>	<b>3. Recipient's Accession No.</b>
<b>4. Title and Subtitle</b> The Ecology of Barataria Basin, Louisiana: An Estuarine Profile		<b>5. Report Date</b> July 1987	
<b>7. Author(s)</b> W.H. Conner and J.W. Day, Jr.		<b>6.</b>	
<b>9. Performing Organization Name and Address</b> Coastal Ecology Institute Center for Wetland Resources Louisiana State University Baton Rouge, LA 70803		<b>8. Performing Organization Rept. No.</b>	
<b>12. Sponsoring Organization Name and Address</b> U.S. Fish and Wildlife Service National Wetlands Research Center Department of the Interior Washington, DC 20240		<b>10. Project/Task/Work Unit No.</b>	
		<b>11. Contract(C) or Grant(G) No.</b> (C) (G)	
		<b>13. Type of Report &amp; Period Covered</b>	
		<b>14.</b>	
<b>15. Supplementary Notes</b>			
<b>16. Abstract (Limit: 200 words)</b> The Barataria Basin lies entirely in Louisiana between the natural levees of the active Mississippi River and the abandoned Bayou Lafourche distributary. It is characterized by a network of interconnecting water bodies which allows transport of water, materials, and migrating organisms throughout the basin. Natural and artificial levees and barrier islands are the only high, well-drained ground in the basin, which is otherwise characterized by extensive swamp forests and fresh, brackish, and salt marshes. These wetlands and water bodies are extremely productive biologically and provide valuable nursery habitat for a number of commercial and recreational fish and shellfish, as well as habitat for wintering waterfowl and furbearers.  The basin is a dynamic system undergoing constant change because of geologic and human processes. The network of bays, lakes, and bayous has gradually enlarged over time due to natural subsidence and erosion. Superimposed on these natural processes has been the construction of levees for flood control and a network of canals constructed for oil and gas exploration and extraction. These human activities have altered natural hydrologic patterns in the basin and may directly or indirectly contribute to wetland losses. Controlling wetland deterioration in the basin is a major management concern.			
<b>17. Document Analysis</b>			
<b>a. Descriptors</b> Estuaries, ecology, geology, hydrology, climate, nekton, biological productivity			
<b>b. Identifiers/Open-Ended Terms</b> Wetlands, energy flow, nutrient cycling, marshes			
<b>c. COSATI Field/Group</b>			
<b>18. Availability Statement</b> Unlimited distribution		<b>19. Security Class (This Report)</b> Unclassified	<b>21. No. of Pages</b> 165
		<b>20. Security Class (This Page)</b> Unclassified	<b>22. Price</b>

(See ANSI-Z39.18)

OPTIONAL FORM 272 (4-77)  
(Formerly NTIS-35)  
Department of Commerce



