

GOVERNMENTWIDE
ACCOUNTING & REPORTING

gwa
Modernization



Governmentwide Accounting Modernization Project Day

GWAMP Day: Policy Impacts and System Changes

April 25, 2007

Objective

- Change the fundamental reconciliation process
- Eliminate the redundant reporting processes
- Provide accounting information in a more timely manner
- Provide a central location for accounting data
- Streamline agency access
- Replace the current Legacy Central Accounting System
(STAR)



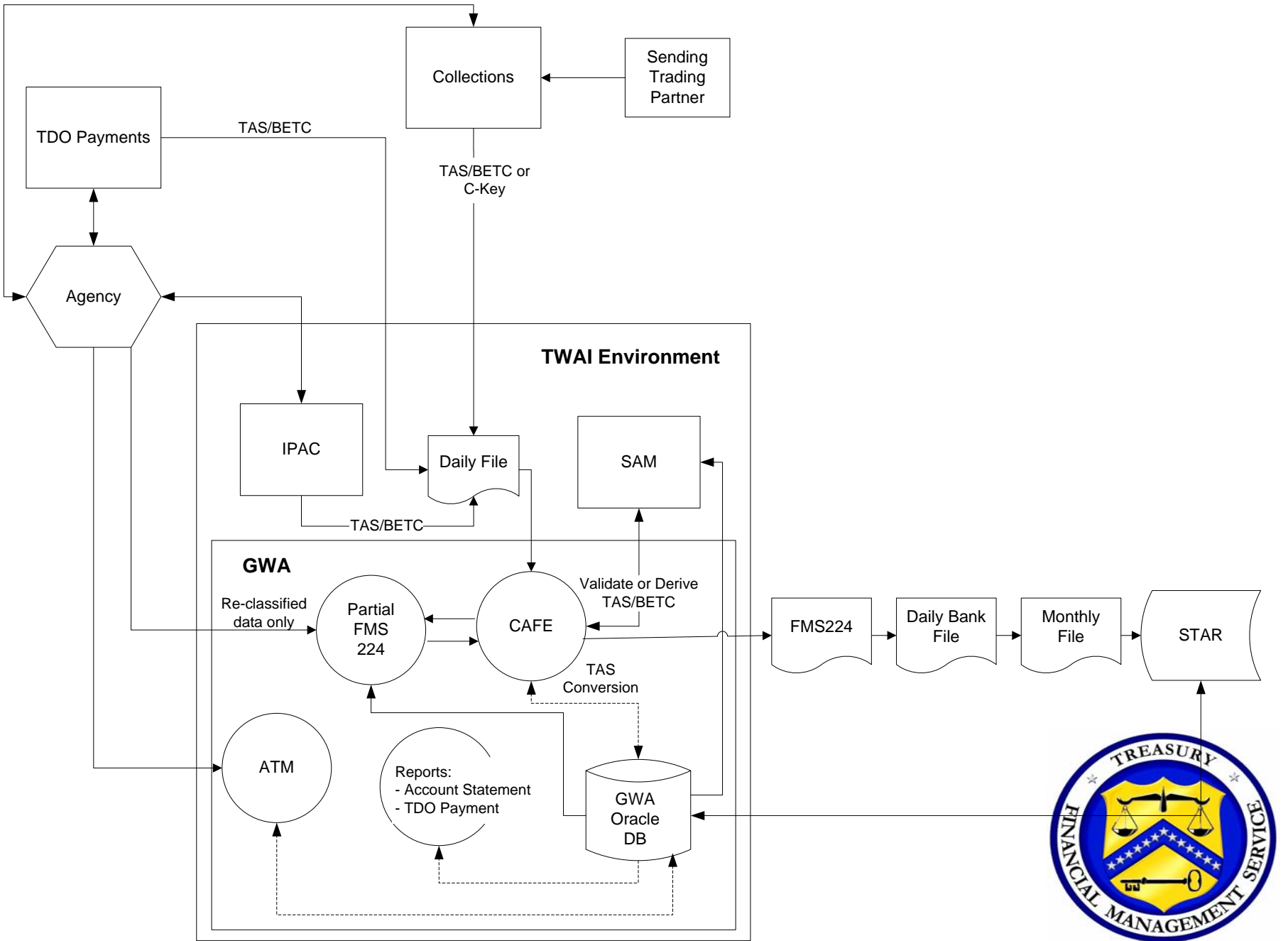

Implementation Strategy

- Develop a method to bring on the maximum number of agencies as soon as possible
 - Implement feeder mechanisms (IPAC, Payments, Collections) in phase in approach
 - Develop tools to assist in implementation (SAM, Account Statement)
- Provide a tool for agencies to phase in GWA processing
 - P224 provides for reclassification capability by using only section I of the 224
 - Ability to turn off sections of the P224
- Incremental approach allows for efficient planning scheduling of resource utilization and testing in manageable parts



Why Become A GWA Player?

- Reduced end of month reporting
- Improved reconciliation processing
- Most current fund balance available
- Improved turnaround on processed data
- Resources available to assist



What should my agency be doing to prepare?

- ✓ Set up your Trading Partner Agreement with your customers
- ✓ Communicate with your trading partners
- ✓ Modify your accounting systems to provide and accept TAS/BETC on IPAC transactions
- ✓ Work with SAM implementation team to set up profiles/default rules
- ✓ Contact FMS to become a GWA Player



Current GWA Players

- Bureau of Public Debt (BPD)
- Financial Management Service (FMS)
- Internal Revenue Service (IRS)
- Government Printing Office (GPO)

Future GWA Players

- Federal Energy Regulatory Commission
- IRS Service Centers



Lessons Learned

- Complexity and differences of agency accounting processes
 - PAIR Team
- Amount of time needed for system changes
- Agency education needed for transaction reporting
 - Develop GWA Player package
- FMS knowledge/resources to assist agencies in implementation
 - PAIR Team



GWA Wants You!

- Do you have what it takes to be a pilot?
 - ALC must be a 224 reporter
 - SOD's must be clear
 - Be prepared to capture TAS/BETC info
 - Willing to participate



GWAMP Roll out Strategy

Action	Target Date	Impact on Agency
ALL IPAC ALCs must have current [STAR] TAS for sender side	Now	CURRENT REQUIREMENT – <i>Valid IPAC TAS only</i>
ATM Module implementation	August 2006	Replaces current NET, Borrowing and Warrant JV applications Need to be enrolled as a GWA user
First GWA Players live	October 2006	Impacts 4 GWA players and their trading partners
New User enrollment process. http://fms.treas.gov/gwa/forms.html	Ongoing	For GWA Applications, Agencies are required to enroll using new process
Additional IPAC ALCs to include current TAS/BETC on both sides of IPAC transactions	October 2006 – August 2008	Impacts IPAC ALCs and their trading partners.
Agencies research and prepare to provide valid TAS/BETCs on both sides of IPAC transactions	ASAP	All IPAC reporters



GWAMP Roll out Strategy

Action	Target Date	Impact on Agency
Update Trading Partner Agreements to include BOTH Treasury Account Symbol (TAS) and Business Event Type Code	ASAP	Must know how [Business Event Type Code - BETC] transactions are affecting what TASs
Agencies to Implement P224 Functionality via FSIO COTS Packages or home grown systems TESTED AND IN PRODUCTION	4 th quarter 2007	Agencies will move to P224 once they become a GWA Player
Complete testing & certifying to ensure that ALL FSIO vendors can provide valid GWA TAS/BETCs on both sides of IPAC Bulk Files	4 th Quarter 2007	Agencies need FSIO certification to implement new functionality
ALL FPA systems must be able to provide valid GWA TAS/BETCs on BOTH sender and receiver sides for IPAC bulk files TESTED AND IN PRODUCTION	3rd quarter 2008/09	Once IPAC turns on the GWA TAS, any current TAS formats will NOT be accepted
IPAC Turn on GWA TAS/BETC both sides	3rd quarter 2008/09	FMS is working with FSIO to determine a new implementation date http://fms.treas.gov/gwa/factsheet_tas.html



GWAMP Roll out Strategy

Action	Target Date	Impact on Agency
Payment Pilots – Valid GWA TAS/BETC’s on Transactions	3 rd quarter 2007	GWA Compliant
Implementation of GWA Initiated Account Statement -	2008	Transactions available at detail level
Agency Partnership Council	Quarterly	Agency participation at every meeting
ATM 2.0 – Appropriation Warrants	3 rd quarter 2007	Add access to Appropriation to current ATM access
All TDO Payment ALCs to include valid GWA TAS/BETCs on Payment Schedules	2009	100 TAS/BETC’s per Payment and per Schedule
Collection Pilots – Begin working with collection pilots to ensure valid GWA TAS/BETCS or Classification keys [Ckeys] are on all collection transactions	4th quarter 2007	
All Collection ALCs to include valid GWA TAS/BETCs or Ckeys on collection transactions	2009	GWA Compliant Ckeys identified and set up in the Shared Accounting Module [SAM] for translation to valid TAS/BETC’s



Contact Information

GWA Modernization Project

- Michael Norman – (202) 874-8788 – michael.norman@fms.treas.gov
- Anna Hancock – 202-874-9868 – anna.hancock@fms.treas.gov
- Web site – www.fms.treas.gov/gwa
- Email box – GWA.Project@fms.treas.gov
- Enrollment – GWA.Enrollment@fms.treas.gov

IPAC Project

- Susan Markland - (202) 874-9816 – susan.markland@fms.treas.gov
- Lori Makle-Sellman - (202) 874-8782 – lori.makle-sellman@fms.treas.gov

SAM

- Robin Gilliam – (202) 874-9133 – robin.gilliam@fms.treas.gov
- Cheryl Murray – (202) 874-7078 – cheryl.murray@fms.treas.gov

GWA Project Agency Outreach

- Carolyn Dunston - 202-874-7491 – carolyn.dunston@fms.treas.gov
- Peter Moore – 202-874-6578 - Peter.moore@fms.treas.gov



GOVERNMENTWIDE
ACCOUNTING & REPORTING

gwa
Modernization



**TREASURY ACCOUNT
SYMBOL/BUSINESS EVENT TYPE
CODE (TAS/BETC)**

Standardizing and Reengineering

GWAMP Day: Policy Impacts and System Changes

April 25, 2007

- Acronym for Treasury Account Symbol, TAS refers to the receipt, appropriation, and other fund account symbols and titles as assigned by the Department of the Treasury.
- Format Standardization - move towards TAS component pieces, supports CGAC



What are the TAS Changes?

- Elimination of Standard Subclasses – replaced by BETC.
 - Example: Subclass “88” replaced by BETC “INVTSEC”
 - “(88)20x1234” replaced by “20x1234 INVTSEC”
- Former Subclass field renamed to “Sub-level Prefix” – only used for programmatic breakdowns of the TAS for Treasury publication purposes; have a unique meaning or unique need for sub-classification that is NOT based on transaction types or business events.
 - Example: Sub-level prefix “15” on 20x8005 represents “Refunds of Taxes”
 - Sub-level prefix “16” on 20x8005 represents “Admin Expenses”
 - Both sub-level prefixes of this TAS have same business event of DISB, but are presented on different tables of the Monthly Treasury Statement



What are the TAS Changes?

- Expansion of Dept Agency Codes – from 2 to 3
 - Current 2 digit department codes will be right justified and zero filled
 - Standardized names: From “Dept Regular” to “Agency Identifier”
 - From “Dept Transfer” to “Allocation Transfer Agency Identifier”
- Expansion of Fiscal Year –
 - String-based GWA TAS expands FY to 2 characters;
Multi-year is 5 characters (2 years separated with a slash)
 - Component-based GWA TAS expands FY to 4 characters each
Beginning FY and Ending FY each have separate fields
Alpha characters (X, F) are also in separate field



String TAS Format

Description of Data Element within the string	Example
The Sub-level Prefix (if populated) is the first two characters of the TAS separated from the rest of the TAS by parenthesis. The Sub-level Prefix represents a programmatic breakdown of the account for Treasury publication purposes.	(01)
The Agency Identifier - Treasury Agency Code of the Agency Owner.	(01)14
If authority for the Account has been transferred from the Agency Owner to another agency, the Agency Owner will move to the third element of the TAS. The Co-Owner will move to the second position immediately before the Agency Owner, separated by a hyphen.	(01)14-11
The Fiscal Year, if presented, will contain a two-character year field , a five character multi-year field (two years separated with a '/'), or a single alpha character.	(01)14-11X (01)14-1101 (01)14-1101/02
The Main Account Number represents the type of Fund and the purpose of the account within that Fund.	(01)14-11X0300
The Sub-Account Symbol Identifies an available receipt or other Treasury-defined subdivision of the main account. Valid ranges are 1 - 999 and are presented immediately following the Main Account Number separated by a '!'. There will be no leading zeroes in this field.	(01)14-11X0300.1

Component TAS Format

Field Name and Description	Size	Example
Sub-level Prefix - if populated, is a programmatic breakdown of the account for Treasury publication purposes. If Sub-level Prefix does not apply, it shall be two spaces.	2	01
Agency Identifier – Agency Identifier of the Account Owner. Current 2 digit department codes will be right justified and zero filled.	3	014
Allocation Transfer Agency Identifier - the agency identifier of the agency receiving funds through an allocation transfer. If Department Transfer does not apply, it shall be spaces. Current 2 digit department codes will be right justified and zero filled.	3	011
Beginning Period of Avail – In annual and multiyear accounts, identifies the first year of availability under law that an appropriation account may incur new obligations. If single/annual year account, shall be same as Ending Period of Avail. No X or F accounts.	4	2001 2001
Ending Period of Avail - In annual and multi-year funds, identifies the last year of funds availability under law that an appropriation account may incur new obligations.	4	2001 2002
Availability Indicator – Identifies no-year “X” accounts, suspense/clearing “F” accounts, Treasury’s Central Summary General Ledger “A” account, and merged-surplus “M” accts.	1	X
Main Account - represents the type of Fund and the purpose of the account within that Fund.	4	0300
Sub-Account - Identifies an available receipt or other Treasury-defined subdivision of the main account	3	001 19

BETC Definition

- Acronym for Business Event Type Code, BETC refers to an 8-character code that indicates the type of activity being reported (e.g. receipt, disbursement, etc.)
- BETC determines the transaction effect on the Treasury Account Symbol's Fund Balance with Treasury
- BETC replaces transaction codes and standard subclasses but at a more intuitive level of detail.



Sample BETC

Code	Activity	Transaction affect on TAS	Trans Code	Sub Class
DISB	Gross Disbursement	D (decrease)	61	--
COLL	Offsetting Collection	C (increase)	71	--
INVTSEC	Investment in Treasury Securities	D (decrease)	61	88
REDTSEC	Redemption of Treasury Securities	C (increase)	71	98



TAS/BETC Codes for IPAC Reporting

To download the full spreadsheet for your reference, go to http://fms.treas.gov/gwa/ref_guidance.html

<http://www.fiscal.treasury.gov/ipac/>
of 3/1/2007

Note: Column G represents the TAS format currently accepted in IPAC. The new standard GWA TAS, represented in column H, will be required in IPAC as of August 1, 2008.

TAS COMPONENT PIECES											BUSINESS EVENT TYPE CODE	BETC DESCRIPTION	IPAC PMT COLL IND
Sub-level Prefix	Agency Identifier	Alloc. Transfer Agency Identifier	Beg. Period of Avail.	Ending Period of Avail.	Avail. Indicator	Main Account	Sub Account Symbol	Current IPAC TAS	GWA TAS String	ACCOUNT TITLE			
	19		2002	2002		1082	000	1921082	19021082	AMERICAN SECTIONS, INTERNATIONAL COMMISSIONS, STATE SALARIES AND EXPENSES, INTERNATIONAL BOUNDARY AND WATER COMMISSION, UNITED STATES AND MEXICO, STATE	COLL	Offsetting Collection	C
	19	72	2002	2002		1069	000	19-7221069	19-72021069	SALARIES AND EXPENSES, FEDERAL LABOR RELATIONS AUTHORITY	DISBAJ	Adjustment to Gross Disbursements	C
	54		2001	2002		0100	000	541/20100	5401/020100	QUALITY OF LIFE ENHANCEMENTS, DEFENSE	COLL	Offsetting Collection	C
	97		2001	2002		0839	000	971/20839	9701/020839	PEACE CORPS, FUNDS APPROPRIATED TO THE PRESIDENT	DISBAJ	Adjustment to Gross Disbursements	C
	11				X	0100	000	11X0100	11X0100		DISB	Gross Disbursements	D

- Currently only displaying TAS/BETCs for IPAC
on GWA Website www.fms.treas.gov/gwa/ref_guidance.html
- Future will display TAS/BETCs for other interfacing systems
- Future will be SAM downloads



GOVERNMENTWIDE
ACCOUNTING & REPORTING

gwa
Modernization



SUSPENSE F" ACCOUNT DISCONTINUANCE AND WAIVER POLICY

GWAMP Day: Policy Impacts and System Changes

April 25, 2007

Governmentwide Accounting

- **Future Plans**

- Capture program level spending on real-time or near-real-time basis



Governmentwide Accounting

- **To Accomplish Future Plans Agencies must:**
 - Classify transactions to the proper Treasury Account Symbol (TAS) **at the time the transaction is executed or the point of origin; e.g. when the collections are made**



Discontinuance of Suspense “F” Accounts

- **FMS will discontinue the use of**
 - **Budget Clearing Account F3875**
 - **IPAC Account F3885**

July 31, 2008



Collections: Budget Clearing “F” Accounts (3875)

- **Agency Action to clear balances:**
 - Correctly classify amounts in accounts
- **If agencies do not classify entire balances, they should take the following actions:**
 - **Positive Balance:**
 - Reallocate their funds to a Miscellaneous Receipts account
 - **Negative Balance:**
 - Charge the balance to an open Appropriation account.
 - Obtain legislation to create a new Appropriation to zero out the account balance



(IPAC) “F” Accounts (3885)

- **Agency Action to clear balances:**
 - Correctly classify amounts in accounts
- **If agencies do not classify entire balances, they should take the following actions:**
 - **Positive Balance**
 - Reallocate their funds to a Miscellaneous Receipts account
 - **Negative balance**
 - Charge the balance to an open Appropriation account
 - Obtain legislation to create a new Appropriation to zero out the account balance



New Federal Government Suspense Account

- FMS establishes Suspense (Clearing) Accounts to **temporarily** hold unidentifiable Collections
 - General Fund
 - Revolving Fund
 - Special Funds
 - Trust Funds



Payments Using “F” Accounts

- **Current policy:**
 - No “F” Accounts allowed
 - Without exception, an “F” account should NEVER be used to make a payment



New Federal Government Suspense Accounts

Federal Agencies classify funds in the suspense account until the Agency can classify them to the proper receipt or expenditure accounts

time limit

60 days



FMS “F” Account Waiver Policy

Agencies that have a justifiable business need to keep suspense accounts may submit a written waiver request to OMB and FMS

by

April 30, 2008



34FMS “F” Account Waiver Policy

New Approved Budget Clearing Accounts will be available on

August 1, 2008



FMS “F” Account Waiver Policy

- **FMS and OMB will approve requests on a case-by-case basis providing the agencies agree to the following account provisions:**
 - Items classified to “F” accounts must be cleared within 60 days (reclassify to proper accounts)



FMS “F” Account Waiver Policy

All F3875 and F3885 accounts must have a zero Balance

February 28, 2009



Pertinent Effective Dates

Effective Date	Event
April 30, 2008	Agencies must submit a written waiver request to OMB and Treasury.
July 31, 2008	FMS will discontinue the use of Budget Clearing Account F3875 and IPAC Account F3885.
August 1, 2008	Any new approved Budget Clearing and IPAC suspense accounts will be available.
February 28, 2009	All F3875 and F3885 accounts must have a zero balance.



Any questions, comments, or assistance
needed

please contact:

Marlana White
(202) 874-0014

or

FMS Budget Reports Division
(202) 874-9870



GOVERNMENTWIDE
ACCOUNTING & REPORTING

gwa

Modernization



INTRA-GOVERNMENTAL PAYMENT AND COLLECTION (IPAC) SYSTEM

GWAMP Day: Policy Impacts and System Changes

April 25, 2007

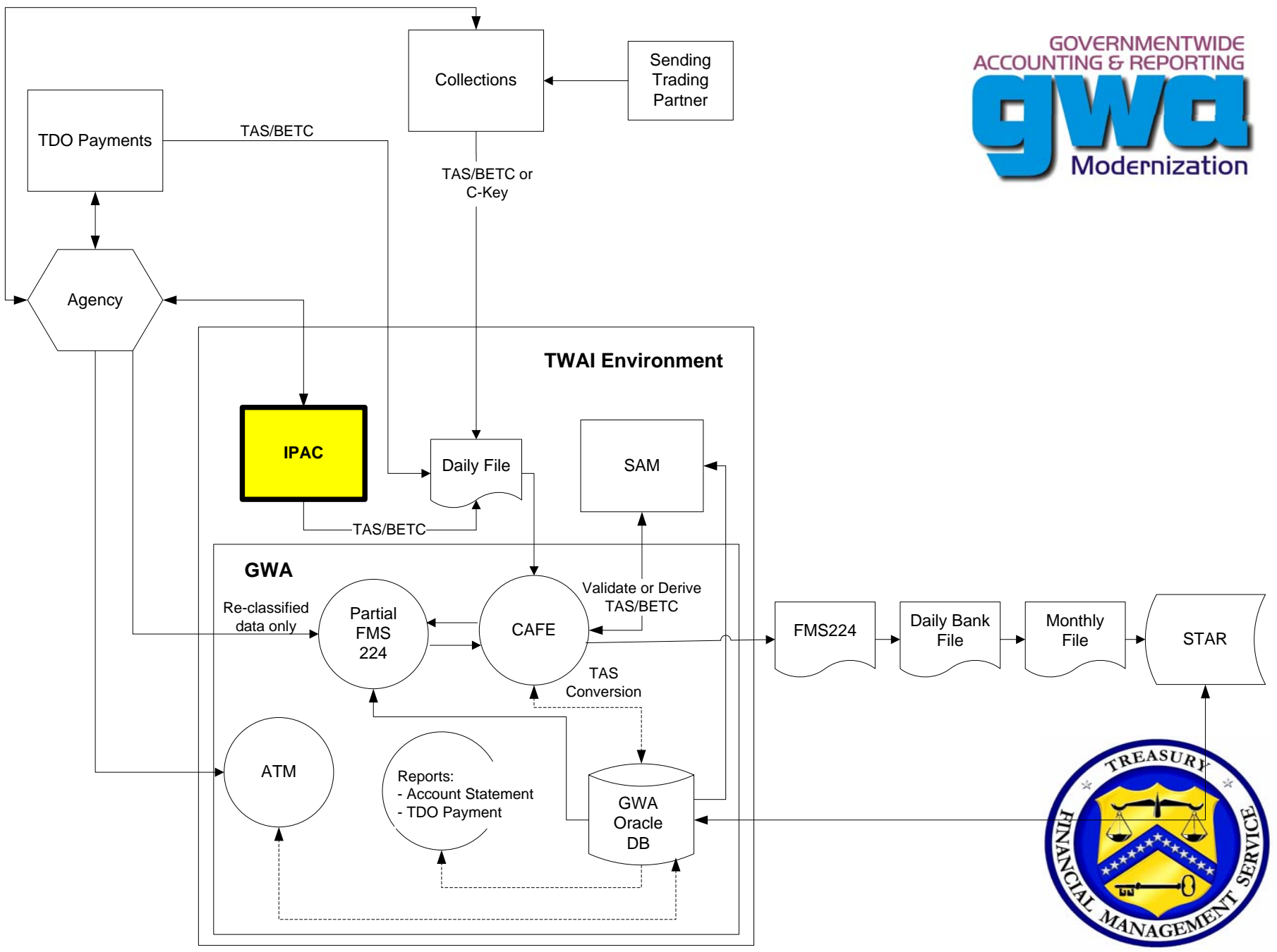



Intra-governmental Payment and Collection System

Purpose

Discuss the GWA Modernization Project objectives impact on IPAC

- Current Status
- Current Reporting Requirements
- In Development
- On the Horizon
- Planning Strategy
- Contacts





Intra-governmental Payment and Collection System

Current Status

- Implemented:
 - October, 2003
 - 27 Character String TAS and 8 Character BETC in bulk file formats
 - March, 2006
 - Online screens updated to include TAS/BETC





Intra-governmental Payment and Collection System

Current Reporting Requirements

- All ALCs report a TAS on the sender side
- Pilot ALCs report a TAS and BETC on sender side
- Trading Partners of Pilot ALCs must report Sender TAS and Receiver TAS/BETC
- Current TAS format is STAR string





Reporting Scenarios

Scenario Sender/Receiver	Sender TAS	Sender BETC	Receiver TAS	Receiver BETC
Non Pilot/Non Pilot	Required			
Pilot/Non-Pilot	Required	Required		
Non Pilot/Pilot	Required		Required	Required
Pilot/Pilot	Required	Required	Required	Required





Intra-governmental Payment and Collection System

Current Capability

- Enter TAS/BETC
- Find a list of BETCs that are valid for TAS
- Wild card search to find valid TAS/BETC
- Select from a history of previous values entered
- If a TAS/BETC is entered even if the field is not designated as mandatory IPAC will reject any transactions with invalid values in those fields





Intra-governmental Payment and Collection System

Payment Entry Screen

IPAC - Payment Entry

Originating ALC: 19000001 Customer ALC: 00005570 Summary Amount: 0.00
 Number of Details: 0

ALC Contact: Robert Zabriskie Contact Phone: 12345678901234567 Contact Email: Robert.Zabriskie@rich.frb.org

Treasury Account Symbol: BETC
 Sender * 50F3880
 History List: 50F3880|Gross Disbursement For Budget Clearing Accounts ▼
 Receiver: 200/10171
 History List: 200/10171|Offsetting Collection ▼

Sender DUNS: 1 Sender DUNS +4: 1 Receiver DUNS: 1 Receiver DUNS +4: 1

Purchase Order Number: * 1 Invoice Number: * 1 Receiver Dept. Code: * 20
 Requisition Number: 1 Contract Number: 1 Obligating Document Number: * 1
 JAS Number: 1 ACT (Trace Number): 1 CLIN: 1
 Quantity: * 1 Unit Price: * 10 Detail Amount: * 10





Intra-governmental Payment and Collection System

In Development

- December, 2007 – IPAC Release 11
 - New Graphical User Interface (GUI)
 - Support of TRACs initiative to eliminate manual 1081s
 - Implementation of Mandatory Unique File ID.
 - Capability to accept GWA Standard TAS (String)
 - Implementation originally targeted for August 1, 2008 (TFM Bulletin No. 2007-04, Volume I)





Intra-governmental Payment and Collection System

Release 11 Capability

- GUI more intuitive
- Ability to mandate Unique Bulk File ID to eliminate duplicate file reporting
- Additional fields in TRACS application to support 1081 eliminations
- Ability to switch to the GWA Standard String TAS
- Search and editing capability will be the same





Payment Entry Screen

Intra-governmental Payment and Collection System



Transactions

Skip Navigation Logout Help Styles off

Thu Feb 22 08:17:52 2007

Last Completed Tran - Accomplished Date: 2007-02-22 Doc Ref: 25111547 Amt: 10.00 ALC: 19000001 Cust ALC: 5570

- IPAC Home
- Transactions
- Query
- Requests
- Bulk Batch
- Agency Setup
- Password
- IPAC Admin
- RITS
- RITS Admin
- TRACS
- TRACS Admin

Step 1 2 3 4 5 DTL# 1

*** Asterisk indicates required fields**

ALC * 19000001

Customer ALC 00005570 [Organization Info](#)

Transaction type * Payment

Document ref. nr.

DO symbol Find

SGL amount > Find

Sender TAS * (41)1110038

BETC FHOTXD Find

History List (41)1110038|Funds Held Outside The Treasury, Debit

Receiver TAS 31X5280.1

BETC COLAVRCT Find

History List 31X5280.1|Collection To An Available Receipt Account

Receiver dept. code * 20 **44**

Purchase order nr. * 1

Invoice nr. * 1

Obligating doc. nr. * 1





Intra-governmental Payment and Collection System

On the Horizon

- Reviewing the strategy for implementing TAS/BETC
 - Phasing in of Pilot ALCs
 - New Implementation Date
 - Only transactions reported to GWA Reporter ALCs are posted
 - TAS/BETCs recorded on IPAC transactions for Non GWA Reporter ALCs are for information only. Non GWA Reporter ALCs must continue to report monthly FMS 224
 - TAS/BETC implementation for payroll offices in the RITS application





Intra-governmental Payment and Collection System

On the Horizon

- Financial Management Line of Business (FMLOB) /
Common Government Accounting Classification (CGAC)
 - Financial Line of Business - TAS/BETC Component Pieces
 - Reimbursable Line of Business - Standardizing IPAC Fields





Intra-governmental Payment and Collection System

On the Horizon

- Central Agency Reporting Team (CRT)
 - Developing recommendations to improve IPAC
 - Support Intra-governmental Business Rules (TFM Bulletin No. 2007-03 Volume I)
 - Improve Governmentwide Accounting and Reporting
 - Eliminate Intra-governmental differences
 - Recommendations September 2007





Intra-governmental Payment and Collection System

Planning Strategy

- Now
 - Provide support GWAMP in implementing new strategy
- Future - Beginning September 2007
 - Consider upcoming initiatives
 - Analyze Survey Results
 - Form focus groups
 - Prioritize recommendations
 - Develop plan for implementing recommendations and mandates





Intra-governmental Payment and Collection System

Release 11 - Training

Available October 2007

- Tutorials
- Training Environment
- Online Help
- Treasury Support Center





Intra-governmental Payment and Collection System

Contacts

FMS

Susan Markland, Project Director	202-874-9816
Lori Makle-Sellman, Deputy Director	202-874-8782
Rene Talbert, IPAC Staff	202-874-8942
Kneasha Bragg, IPAC Staff	202-874-6610
Keshawn Moore, IPAC Staff	202-874-1112

IPAC Help Desk

Treasury Support Center	866-809-5218
-------------------------	--------------



GOVERNMENTWIDE
ACCOUNTING & REPORTING
gwa
Modernization



SHARED ACCOUNTING MODULE SAM

GWAMP Day: Policy Impacts and System Changes

April 25, 2007

Collections

TAS/BETC or
C-Key

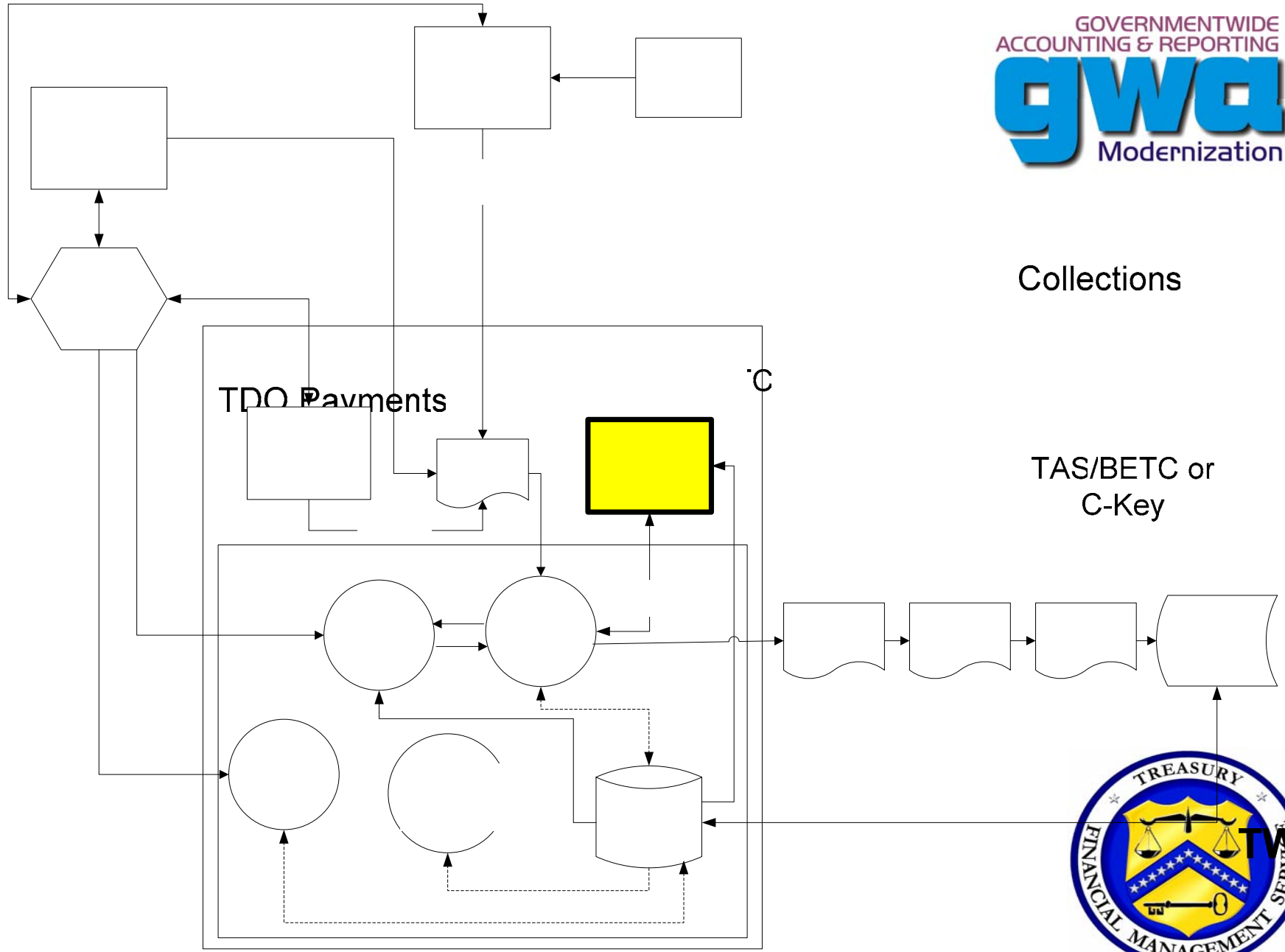

TWAI

SAM Background



The Shared Accounting Module is an application developed by FMS in conjunction with FRB St. Louis. SAM will facilitate the process of validating or deriving Treasury Account Symbol (TAS) / Business Event Type Code (BETC) accounting codes to assist GWA in classifying all financial transactions on a real-time basis.



The Business Problem

- GWA Modernization changes certain central accounting parameters (i.e., timing and information flow)
- Payments and collections must be classified to a TAS/BETC combination as early as possible, replacing the monthly FMS 224 reporting cycle
- Collections must be classified when the money is received - a particular challenge in the new GWA model
- Master reference information on Agency Location Codes (ALC), TAS, and BETC's must be readily available to feeder systems and for input validation



The Technical Solution

- To facilitate GWA Modernization, FMS has built a
- Shared Accounting Module (SAM) which will:
 - Leverage existing agency processes to derive TAS/BETC classifications for collections and other transactions
 - NOT place the burden of central accounting on financial institutions processing collections
 - Provide reference tables of TAS, BETC, and ALC data to FMS, Federal Program Agencies (FPA) and the general public.
 - Validate TAS/BETC data wherever submitted through feeder systems



Benefits

SAM will provide FPAs with:

- The ability to reduce the workload associated with dual reporting and multiple reconciliations as required under the current system
- The ability to maintain real-time control over account code translation rules.
- The ability to maintain a single database in which to enter accounting rules versus having to maintain the same rules in multiple collection feeder systems



Benefits continued

SAM will provide FMS with:

- A single source for maintaining similar TAS-related functionality across multiple feeder systems
- An accurate, single touch point, to validate and/or derive TAS/BETC account codes for financial transactions. This process will facilitate the GWA system in classifying work on a daily basis thereby eliminating the need to perform month-end classifications (224 process) when the system is fully implemented.



SAM Interfaces

- GWA
- Central Accounting Front End (CAFÉ)
- Direct Internet Access
- Downloading Service to acquire GWA Master Data
- Uploading Service to acquire Cash Flow Profiles



SAM Connects FPAs with GWA

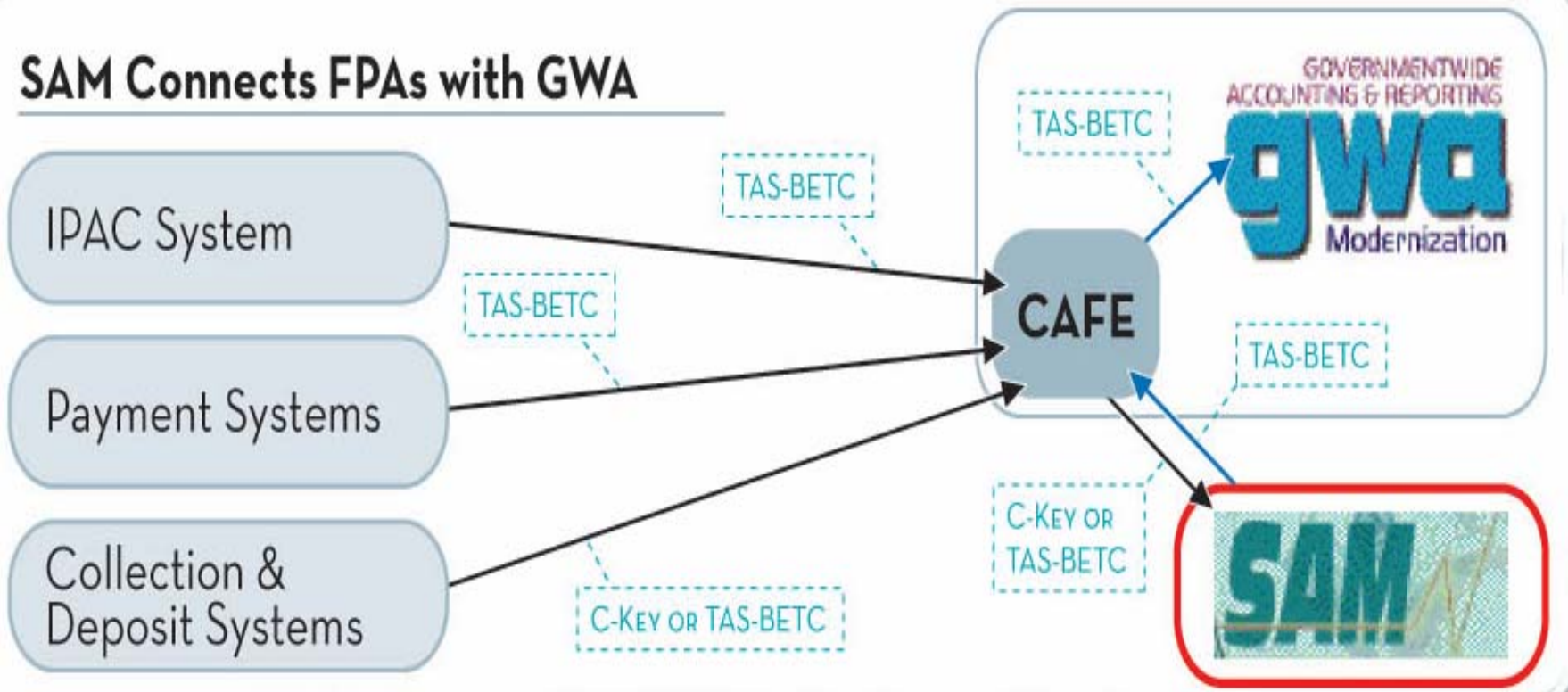

Information Processing

SAM will:

- Receive information from CAFÉ
- Validate TAS/BETC or
- Derive valid TAS/BETC from Ckey or
- Default to a valid TAS/BETC
- Return information to CAFE with valid TAS/BETC and Result Codes



Access Group Set-Up

- A collection of related ALCs will be identified by an agency for inclusion in an Access Group
- The Access Group will be given a name that is identified by the agency
- Users will be defined and will be granted permission to the Access Group



Access Group Set-Up Continued

- Define SAM Users Roles for Access Groups
 - Security Administration
 - Primary Local Administrator (PLSA)
 - Local Security Administrator (LSA)
 - Accounting Administration
 - Cash Flow Administrator (CFA)
 - Agency Viewer
 - Data Download
- Create & Modify Access Group Default Rules



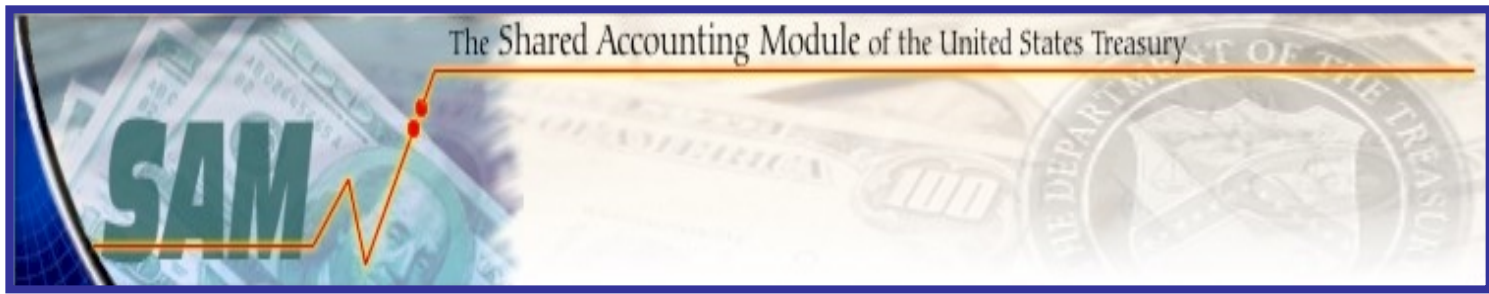

Example of possible Access Group & Subgroups

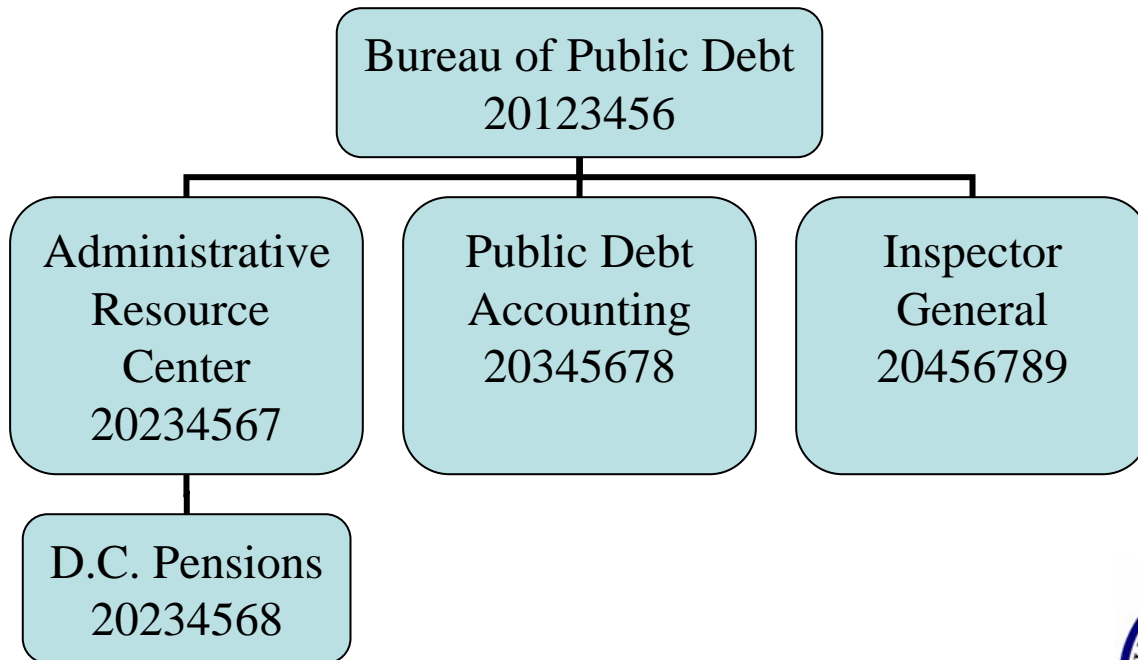

The Derivation Process

Wherever possible, agencies will classify payments and collections up front to TAS/BETC at a summary level

Where up-front classification is not possible, agencies will identify key transaction fields which enable them to classify collection transactions to TAS/BETC combinations. These fields are referred to as Classification Keys (CKeys for short)

When validation or derivation fails, transactions will be applied to a default account that is set up in SAM.



The Default Process

Default Rule Set Up:

GWA Operations assigns an Acceptable Default Account:

- F3500 – Collection/Payment
- F3502 – IPAC

FPA Cash Flow Administrator (CFA) selects System Type:

- IPC
- Disbursement
- Collection

FPA - CFA selects Access Group

FPA - CFA selects a TAS and BETC for Debit and Credit rules



The Default Process

Default Rule Example:

System Type: IPC

Agency: 20 – Department of Treasury

Access Group: Bureau of Public Debt

ALC: 20123456

Default Account:

Debit Rule: 20F3502 DISBBCA

Credit Rule: 20F3502 COLLBCA



Agency Classification

Classification Key

- Name
- Value

Distribution Rule

- Debit/Credit
- Percentage
- TAS/BETC



Agency Classification Continued

FPA's will define accounting rules within SAM called a Cash Flow Profile that will identify how their financial transactions should be classified

Classification Key Definition:

Name – Up to 25 alphanumeric characters

CKey Name: LOCK BOX ACCOUNT NUMBER

Value (Optional Field) – Up to 50 alphanumeric characters

CKey Value: 123456



Agency Classification Continued

FPA's may create rules for CKeys within the SAM Cash Flow Profile that will identify how their financial transactions should be distributed

Distribution Rule:

One to One:

CKey Name: LOCK BOX ACCOUNT NUMBER

CKey Value: 123456

Rule: LOCK BOX ACCOUNT NUMBER 123456

dr 100% 20X1234 COLLAJ

cr 100% 20X1234 COLL



Agency Classification Continued

FPA's may create rules for CKeys within the SAM Cash Flow Profile that will identify how their financial transactions should be distributed

Distribution Rule:

One to Many:

CKey Name: LOCK BOX ACCOUNT NUMBER

CKey Value: 654321

Rule: LOCK BOX ACCOUNT NUMBER 654321

dr 75% 20X1234 COLLAJ

dr 25% 20X1235 COLLAJ

cr 75% 20X1234 COLL

cr 25% 20X1235 COLL



Summary

- The Shared Accounting Module (SAM) was developed to support GWA's strategy of capturing a TAS and BETC at the time a transaction is reported, thereby facilitating the timely and accurate reporting of Federal Program Agency (FPA) financial transaction information.
- Support the implementation of new, more efficient and effective business processes for central accounting
- Eliminate the need to modify up to 30 collections processing systems to support GWA modernization



Current Activities

In order to collect Cash Flow Profile information the SAM Conversion Team is partnering with ARM to contact FPA's and discuss the 224 preparation process.

During the call the SAM Team will try to capture an overview of how the FPA handles incoming revenue by:

- Discussing each of an FPA's collection systems
- Determining # of TASs used for collections
- Identifying internal accounting codes to be used as C-Keys



Additional Information

Contact

Cheryl Murray – Project Manager
(202) 874-7078

Cheryl.Murray@FMS.treas.gov

Nikki Kull – Conversion Analyst
(314) 444-4621

Nicole.Kull@stls.frb.org



GOVERNMENTWIDE
ACCOUNTING & REPORTING

gwa

Modernization



PARTIAL 224

GWAMP Day: Policy Impacts and System Changes

April 25, 2007

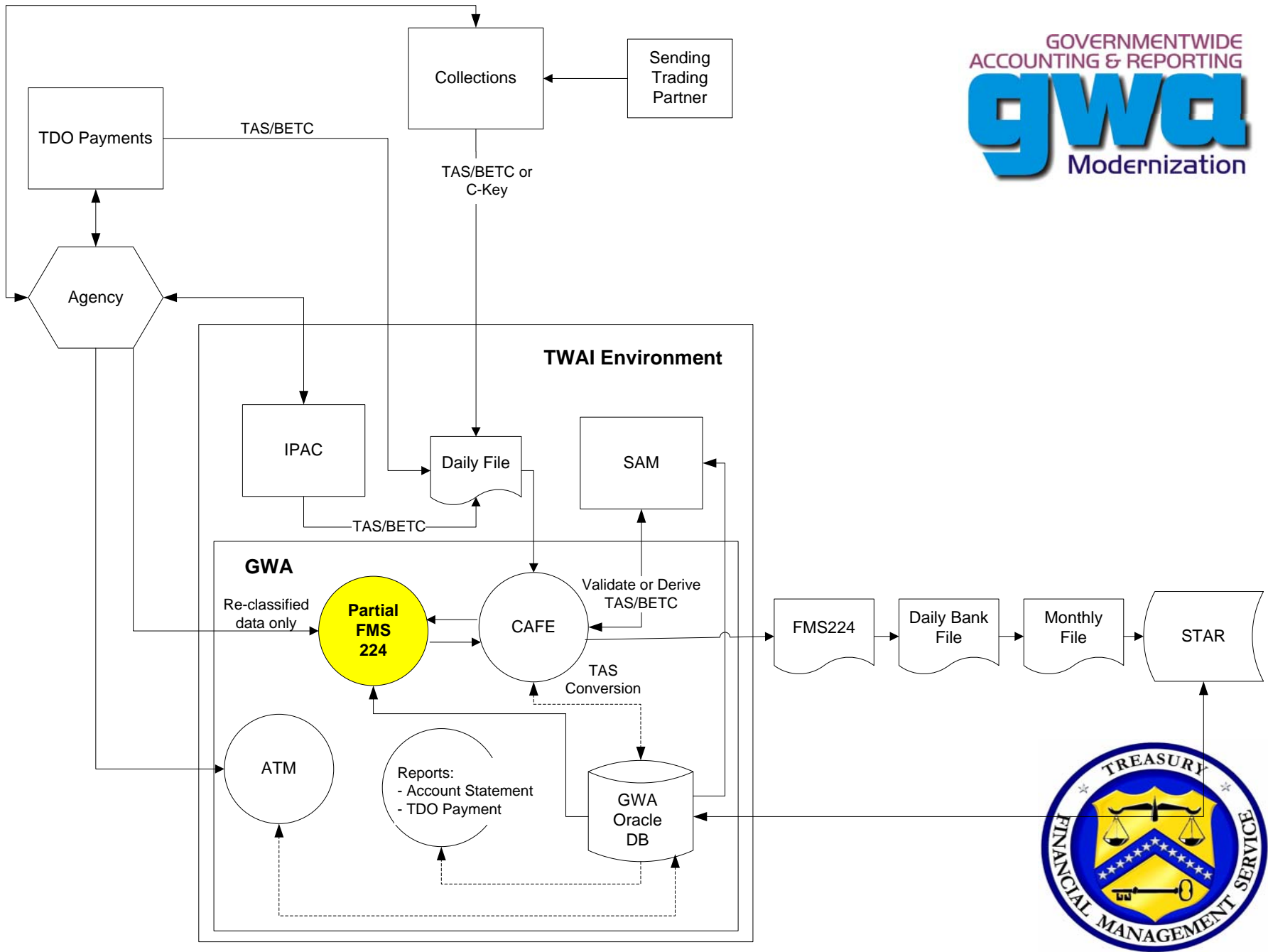

P224 Overview

- The Partial 224 application provides the Federal Program Agencies (FPAs) that utilize FMS Regional Finance Centers for their disbursing activity the capability to submit their monthly statement of transactions to the Financial Management Service (FMS). The Partial 224 application will send its data to **GWA** and **GWA** will then send the data to STAR (Central Accounting System).
- The Partial 224 Online application is comprised of four sections (tabs): Section 1: Reclassifications, Section 2: Payments, Section 3: Collections, and Section 4: the Information tab.
- The Preparer is able to enter data into Sections 1, 2 and 3 based on the type of transactions the agency reports combined with the implementation of each source system.
 - IPAC – currently implemented
 - RFC (TDO) – 2nd Quarter 2007
 - CA\$HLINK (TRS)- 2nd Quarter 2008
- Implementation of source systems allows sections/lines of the Partial 224 application to be enabled or disabled. The Balance section is informational only.

Preparer Log on

GWA Home page Logon - Microsoft Internet Explorer

File Edit View Favorites Tools Help

Back Forward Stop Refresh Home Search Favorites Print Mail News RSS Feeds

Address <https://t0t2qw.it.gwa.gov:8447/gwaPublic/login.fcc?TYPE=33554433&REALMOID=06-000b01f5-9d81-1f00-901c-830bd97d0000&GUID=85MAUTHREASON=0&METHOD=GET&SMAGI> Go

gwa GOVERNMENTWIDE ACCOUNTING SYSTEM

Logon

Logon

Logon

User ID:

Password:

[Forgot Password](#)

WARNING! You are using an official United States Government System, which may be used only for authorized purposes. Unauthorized use or modification of any information on this system is a violation of federal law and may subject you to civil and criminal penalties. The Government may monitor and audit the usage of this system, and all persons are hereby notified that the use of this system constitutes consent to such monitoring and auditing.

[Accessibility](#) | [Contacts](#) | [Privacy Policy](#)

U. S. Department of the Treasury - Financial Management Service

Done Local intranet



Preparer Homepage

GWA for the Web - Microsoft Internet Explorer

File Edit View Favorites Tools Help

Back Forward Stop Refresh Home Search Favorites

Address <https://qa.gwa.gov/gwa/Home> Go

GOVERNMENTWIDE ACCOUNTING & REPORTING **gwa** Modernization

HOME HELP LOG OFF

-- Go To -- Go

Welcome, Sheila Higgs 04/17/2007 07:56:25 AM EDT

Home Transactions

Home

My GWA:

[Notices](#)

04/02/2007 04:11 PM- Problems

[Profile](#)

[ALC Address File](#)

[News](#)

04/02/2007 04:35 PM- Testing IE 7.0

[System Alerts](#)

04/02/2007 04:10 PM- QA Environment

[About GWA](#)

My GWA: Notices

04/02/2007 04:11 PM Problems

There has been no issues.
There has been no issues so far.

03/30/2007 03:58 PM eroc production link

[eroc production link](#)
test 9

03/30/2007 03:55 PM go, go, go

go, go, go
test7

03/05/2007 01:23 PM Transformation completed successfully in 37 seconds

Transformation completed successfully in 37 seconds

[Contact Us](#) | [Accessibility](#) | [Privacy Policy](#)

U. S. Department of the Treasury - Financial Management Service

Done Internet



Transaction Page

GWA for the Web - Microsoft Internet Explorer

File Edit View Favorites Tools Help

Address <https://it.gwa.gov:8447/gwa/newTransactions.do> Go

GOVERNMENTWIDE ACCOUNTING & REPORTING
gwa
Modernization

HOME HELP LOG OFF

-- Go To -- Go

Welcome, P224P P224Preparer27 01/26/2006 09:08:33 AM EST

Home ▾ Transactions ▾

Partial FMS 224 ▾

Home > Transactions > Partial FMS 224

Transactions

Partial FMS 224

- [Online Interface System](#)
- [BulkFile Interface System](#)

[Accessibility](#) | [Contacts](#) | [Privacy Policy](#)

U. S. Department of the Treasury - Financial Management Service

Local intranet



Partial 224 Sections

When all source systems are implemented, agencies will only be able to report Reclassifications in Section 1. Until then, FMS is bringing on source systems one at a time starting with IPAC, then RFC (TDO) and finally CA\$HLINK (TRS).



Section 1: Reclassification

Sectional - Microsoft Internet Explorer

File Edit View Favorites Tools Help

Back Forward Stop Home Search Favorites Refresh Print Mail Stop Taskbar

Address https://ft.gwa.gov/GWAGovPartial224Web/aLCDetails.do?submit.action=retrieve.specificMonth&alc=12250001&rpt_Month=200703&rpt_Type_Code=0&transmit_Ind=N Go

GOVERNMENTWIDE ACCOUNTING & REPORTING **gwa** Modernization

Welcome, Sheila Higgs 04/19/2007 08:58:05 AM EDT

HOME HELP LOG OFF

-- Go To -- Go

Partial FMS 224

Online Interface System Bulk File Interface System

Home > Transactions > FMS Partial 224 Online

Current ALC: **12250001** - Rpt Month: **200703** - Rpt Type: **Original**

Reclassification Payments Collections In Balance

Search Criteria - 0 transactions met your criteria. [Text](#) [CSV](#)

Account : --All-- Comparison : Equals

1 - 0 of 0 matches

Appropriation, Fund or Receipt Account	Entry Number	Receipts and Collections Credited to Appropriation or Fund Accounts	Gross Disbursements
Cumulative Subtotal:		0.00	0.00

New... Modify... Delete

1 - 0 of 0 matches

Net Total, Section 1	Net Total(Disb-Rec)	0.00
Net Total, Section 2		0.00

Done Internet



Section 2: Payments

Sectional - Microsoft Internet Explorer

File Edit View Favorites Tools Help

Address https://ft.gwa.gov/GWAGovPartial224Web/aLCDetails.do?submit.action=retrieve.specificMonth&alc=12250001&prt_Month=200703&rpt_Type_Code=0&transmit_Ind=N

GOVERNMENTWIDE ACCOUNTING & REPORTING **gwa** Modernization

HOME HELP LOG OFF

Welcome, Sheila Higgs 04/19/2007 08:58:05 AM EDT

Partial FMS 224

Online Interface System BulkFile Interface System

Home > Transactions > FMS Partial 224 Online

Current ALC: 12250001 - Rpt Month: 200703 - Rpt Type: Original

Reclassification	Payments	Collections	In Balance
1. Payments Transactions Accomplished			
This Month	0.00		
Prior Month (Total) +	0.00	=	0.00
2. Collections Received This Month			
			0.00
3. Net Total, Section 2			
		=	0.00
4. Net Total, Section 1			
			0.00
Prior Month		Amount	
Total:		0.00	

Buttons: New... Modify... Delete

Done Internet



Section 3: Collections

Sectional - Microsoft Internet Explorer

File Edit View Favorites Tools Help

Back Forward Stop Home Search Favorites Refresh Print Mail Stop

Address https://ft.gwa.gov/GWAGovPartial224Web/aLCDetails.do?submit.action=retrieve.specificMonth&alc=12250001&rpt_Month=200703&rpt_Type_Code=0&transmit_Ind=N Go

GOVERNMENTWIDE ACCOUNTING & REPORTING **gwa** Modernization

HOME HELP LOG OFF

-- Go To -- Go

Welcome, Sheila Higgs 04/19/2007 08:58:05 AM EDT

Partial FMS 224

Online Interface System BulkFile Interface System

Home > Transactions > FMS Partial 224 Online

Current ALC: 12250001 - Rpt Month: 200703 - Rpt Type: Original

Reclassification	Payments	Collections	In Balance
1. Balance of Undeposited Collections, Text CSV			
Close of Preceding Month	0.00		
2. Collections Received This Month			0.00
3. Deposits Presented or Mailed to Bank This Month	<input type="text" value="0.00"/>		
Prior Month (Total) +	0.00	=/	0.00
4. Net Total, Section 3			0.00
Prior Month	Amount		
Total:			0.00

New... Modify... Delete



Section 1: Reclassification

Sectional - Microsoft Internet Explorer

File Edit View Favorites Tools Help

Address https://qa.gwa.gov/GWAGovPartial224Web/aLCDetails.do?submit.action=retrieve.specificMonth&alc=20091800&rpt_Month=200703&rpt_Type_Code=0&transmit_Ind=N

GOVERNMENTWIDE ACCOUNTING & REPORTING **gwa** Modernization

Welcome, Sheila Higgs

HOME HELP LOG OFF

-- Go To -- Go

04/18/2007 02:52:02 PM EDT

Partial FMS 224

Online Interface System BulkFile Interface System

Home > Transactions > FMS Partial 224 Online

Current ALC: **20091800** - Rpt Month: **200703** - Rpt Type: **Original**

Reclassification Payments Collections In Balance

Search Criteria - 0 transactions met your criteria.

Account: --All-- Comparison: Equals

1 - 0 of 0 matches

Appropriation, Fund or Receipt Account	Entry Number	Receipts and Collections Credited to Appropriation or Fund Accounts	Gross Disbursements
Cumulative Subtotal:		0.00	0.00

1 - 0 of 0 matches

Net Total, Section 1	Net Total(Disb-Rec)	0.00
Net Total, Section 2		0.00

Done Internet



Section 2: Payments

Sectional - Microsoft Internet Explorer

File Edit View Favorites Tools Help

Back Forward Stop Home Search Favorites Refresh Print Mail Stop

Address https://qa.gwa.gov/GWAGovPartial224Web/alCDetails.do?submit.action=retrieve.specificMonth&alc=20091800&rpt_Month=200703&rpt_Type_Code=0&transmit_Ind=N Go

GOVERNMENTWIDE ACCOUNTING & REPORTING **gwa** Modernization

HOME HELP LOG OFF

-- Go To -- Go

Welcome, Sheila Higgs 04/18/2007 02:52:02 PM EDT

Partial FMS 224

Online Interface System BulkFile Interface System

Home > Transactions > FMS Partial 224 Online

Current ALC: **20091800** - Rpt Month: **200703** - Rpt Type: **Original**

Reclassification	Payments	Collections	In Balance
1. Payments Transactions Accomplished			
This Month	<input type="text" value="0.00"/>		
Prior Month (Total) +	0.00	=	0.00
2. Collections Received This Month			
		.	<input type="text" value="0.00"/>
3. Net Total, Section 2			
		=	0.00
4. Net Total, Section 1			
			0.00
Prior Month	Amount		
Total:			0.00

New... Modify... Delete

Done Internet



Section 3: Collections

Sectional - Microsoft Internet Explorer

File Edit View Favorites Tools Help

Back Forward Stop Home Search Favorites Refresh Print Mail Stop

Address https://qa.gwa.gov/GWAGovPartial224Web/aLCDetails.do?submit.action=retrieve.specificMonth&alc=20091800&rpt_Month=200703&rpt_Type_Code=0&transmit_Ind=N Go

GOVERNMENTWIDE ACCOUNTING & REPORTING **gwa** Modernization

Welcome, Sheila Higgs

HOME HELP LOG OFF

-- Go To -- Go

04/18/2007 02:52:02 PM EDT

Partial FMS 224

Online Interface System BulkFile Interface System

Home > Transactions > FMS Partial 224 Online

Current ALC: **20091800** - Rpt Month: **200703** - Rpt Type: **Original**

Reclassification	Payments	Collections	In Balance
1. Balance of Undeposited Collections.			
Close of Preceding Month	0.00		
2. Collections Received This Month			0.00
3. Deposits Presented or Mailed to Bank			
This Month	<input type="text" value="0.00"/>		
Prior Month (Total) +	0.00	≠	0.00
4. Net Total, Section 3			0.00
Prior Month	Amount		
Total:			0.00

New... Modify... Delete

Internet



Section 1: Reclassification

Sectional - Microsoft Internet Explorer

File Edit View Favorites Tools Help

Back Forward Stop Home Search Favorites Refresh Print Mail News RSS Feeds

Address https://qa.gwa.gov/GWAGovPartial224Web/alCDetails.do?submit.action=retrieve.specificMonth&alc=20090003&rpt_Month=200703&rpt_Type_Code=0&transmit_Ind=N Go

GOVERNMENTWIDE ACCOUNTING & REPORTING **gwa** Modernization

HOME HELP LOG OFF

-- Go To -- Go

Welcome, Sheila Higgs 04/18/2007 02:30:12 PM EDT

Partial FMS 224

Online Interface System BulkFile Interface System

Home > Transactions > FMS Partial 224 Online

Current ALC: **20090003** - Rpt Month: **200703** - Rpt Type: **Original**

Reclassification Payments Collections In Balance

20090003

- 03/2007
- ★02/2007
- ★01/2007
- ★12/2006
- ★10/2006
- ★09/2006
- ★08/2006
- ★06/2006
- ★05/2006
- ★04/2006
- ★02/2006
- ★01/2006
- ★12/2005
- ★11/2005
- ★10/2005
- ★09/2005

Search Criteria - 0 transactions met your criteria.

Account : --All-- Comparison : Equals

1 - 0 of 0 matches

Appropriation, Fund or Receipt Account	Entry Number	Receipts and Collections Credited to Appropriation or Fund Accounts	Gross Disbursements
Cumulative Subtotal:		0.00	0.00

1 - 0 of 0 matches

Net Total, Section 1	Net Total(Disb-Rec)	0.00
Net Total, Section 2		0.00

Done Internet



Section 2: Payments

Sectional - Microsoft Internet Explorer

File Edit View Favorites Tools Help

Back Forward Stop Refresh Home Search Favorites Print Mail News RSS Feeds

Address https://qa.gwa.gov/GWAGovPartial224Web/aLCDetails.do?submit.action=retrieve.specificMonth&alc=20090003&rpt_Month=200703&rpt_Type_Code=0&transmit_Ind=N Go

GOVERNMENTWIDE ACCOUNTING & REPORTING **gwa** Modernization

HOME HELP LOG OFF

-- Go To -- Go

Welcome, Sheila Higgs 04/18/2007 02:30:12 PM EDT

Partial FMS 224

Online Interface System BulkFile Interface System

Home > Transactions > FMS Partial 224 Online

Current ALC: **20090003** - Rpt Month: **200703** - Rpt Type: **Original**

Reclassification	Payments	Collections	In Balance
1. Payments Transactions Accomplished			
This Month	<input type="text" value="0.00"/>		
Prior Month (Total) +	0.00	=	0.00
2. Collections Received This Month			
		.	<input type="text" value="0.00"/>
3. Net Total, Section 2			
		=	0.00
4. Net Total, Section 1			
			0.00
Prior Month	Amount		
Total:			0.00

Internet



Section 3: Collections

Sectional - Microsoft Internet Explorer

File Edit View Favorites Tools Help

Address: https://qa.gwa.gov/GWAGovPartial224Web/aLCDetails.do?submit.action=retrieve.specificMonth&alc=20090003&rpt_Month=200703&rpt_Type_Code=0&transmit_Ind=N

GOVERNMENTWIDE ACCOUNTING & REPORTING
gwa
Modernization

Welcome, Sheila Higgs

HOME HELP LOG OFF

-- Go To -- Go

04/18/2007 02:30:12 PM EDT

Partial FMS 224

Online Interface System BulkFile Interface System

Home > Transactions > FMS Partial 224 Online

Current ALC: 20090003 - Rpt Month: 200703 - Rpt Type: Original

Reclassification	Payments	Collections	In Balance
1. Balance of Undeposited Collections, Text CSV			
Close of Preceding Month	0.00		
2. Collections Received This Month			0.00
3. Deposits Presented or Mailed to Bank This Month	<input type="text" value="0.00"/>		
Prior Month (Total) +	0.00	=/	0.00
4. Net Total, Section 3			0.00
Prior Month	Amount		
Total:			0.00

New... Modify... Delete

Internet



P224 Functions Online Interface System

Online Interface System

The screenshot shows a Microsoft Internet Explorer browser window titled "Treeview ALC - Microsoft Internet Explorer". The address bar displays the URL: <https://it.gwa.gov:8447/GWAGovPartial224Web/p224PassThru.do?opt=Online>. The page content includes the "GOVERNMENTWIDE ACCOUNTING & REPORTING gwa Modernization" logo and navigation buttons for "HOME", "HELP", and "LOG OFF". A "Go To" dropdown menu is also present. The main content area displays a breadcrumb trail: "Home > Transactions > FMS Partial 224 Online". Below this, a list of transaction numbers is shown, each as a blue hyperlink: 20090003, 20090700, 20090800, 20090900, 20091700, 20091800, 20091900, 20092800, 20092900, 20094900, 20096500, and 20098900. The status bar at the bottom indicates "Done" and "Local intranet".



Tree view Expanded

The screenshot shows a Microsoft Internet Explorer window titled "Treeview ALC - Microsoft Internet Explorer". The address bar contains the URL: <https://it.gwa.gov:8447/GWAGovPartial224Web/aLCRelation.do?submit.action=retrieve.allMonths&alc=20090003>. The page header includes the "gwa Modernization" logo, navigation buttons for "HOME", "HELP", and "LOG OFF", and a "Go To" search field. A welcome message reads "Welcome, P224P P224Preparer27" with the timestamp "01/26/2006 09:09:24 AM EST". The main content area is titled "FMS Partial 224 Online" and shows a breadcrumb trail: "Home > Transactions > FMS Partial 224 Online". The current ALC is "20090003". A tree view on the left is expanded to show a list of months from 2004 to 2005. The tree structure is as follows:

- 20090003
 - 12/2005
 - 11/2005
 - 10/2005
 - Supp1
 - 09/2005
 - 08/2005
 - 07/2005
 - 05/2005
 - 02/2005
 - 01/2005
 - 12/2004
 - 11/2004
 - 10/2004
- 20090700
- 20090800
- 20090900



Create a New Original

The screenshot shows a Microsoft Internet Explorer window titled "Treeview ALC - Microsoft Internet Explorer". The address bar contains the URL: <https://qa.gwa.gov/GWAGovPartial224Web/aLCRelation.do?submit.action=retrieve.allMonths&alc=20096500>. The page header includes the "gwa Modernization" logo, a "Welcome, Sheila Higgs" message, and navigation buttons for "HOME", "HELP", and "LOG OFF". The main content area displays a breadcrumb trail: "Home > Transactions > Online Interface System". Below this, a list of ALCs is shown, with "20096500" selected. A modal dialog box titled "Microsoft Internet Explorer" is overlaid on the page, containing the text "Confirmation Please... Create a New Month?..." and "OK" and "Cancel" buttons. The status bar at the bottom indicates "Done" and "Internet".



Copy Previous Month's Data

The screenshot shows a Microsoft Internet Explorer window titled "Treeview ALC - Microsoft Internet Explorer". The address bar contains the URL: <https://qa.gwa.gov/GWAGovPartial224Web/ALCRelation.do?submit.action=retrieve.allMonths&alc=20096500>. The page header includes the "gwa Modernization" logo, navigation links for "HOME", "HELP", and "LOG OFF", a "Go To" search box, and the date "04/18/2007 01:16:12 PM EDT". The main content area is titled "Partial FMS 224" and "Online Interface System". A list of transactions is displayed, with the following entries visible:

- 20090003
- 20090700
- 20090800
- 20090900
- 20091700
- 20091800
- 20091900
- 20092800
- 20092900
- 20094900
- 20096500 (selected)
- ★02/2007
- ★01/2007
- ★12/2006
- ★10/2006
- ★09/2006
- ★08/2006

A "GWA Confirmation -- Web Page Dialog" box is overlaid on the page, containing the text: "Confirmation Please... Copy the previous Months Transactions?...." with "Yes" and "No" buttons. The dialog box also shows the URL <https://qa.gwa.gov/GWAGov> and "Internet".



Reclassification New

Reclassification Edit Transactions - Microsoft Internet Explorer

Address: <https://qa.gwa.gov/GWAGovPartial224Web/reclassification.do?theSelectedReclassRow=0&pgPage=1&reclassButtonAction=ShowReclassTransNew&actionConfirmed=notValid&column>

HOME HELP LOG OFF
-- Go To -- Go

Welcome, Sheila Higgs 04/17/2007 08:02:46 AM EDT

Partial FMS 224
Online Interface System BulkFile Interface System

Home > Transactions > FMS Partial 224 Online

Current ALC: **20090003** - Rpt Month: **200703** - Rpt Type: **Original**

Reclassification		Payments	Collections	In Balance
Appropriation, Fund or Receipt Account	Entry Number	Receipts and Collections Credited to Appropriation or Fund Accounts		Gross Disbursements
<input type="text"/>	0	<input type="text"/>	0.00	<input type="text"/> 0.00

Ok Cancel

Done Internet



P224 Fiscal Year Enhancement

- The account structure currently entered in 224 report allows for one character per fiscal year (maximum of three characters for multi-year that includes a slash). This creates a problem for accounts with fiscal years that spans beyond a decade. For example, account "17 6/8 1611" may be interpreted as 2006/2008 but in reality, it is for 1996/2008. Another example is account "17 0/2 1611" that may have three interpretations: 2000/2002, 1990/2002, 1990/1992.
- To accommodate for accounts with fiscal years that spans beyond a decade, the account structure in Partial 224 will require four characters per fiscal year to avoid any miss-interpretation. For example, account "206/71234" will need to be entered as "202006/20071234".

Examples

- **Single Fiscal Year 4 digits:** 0520010107
- **No year account "X"** 05X0107
- **Multi-year account 9 digits:** 051999/20000107



Reclassification Modify

Reclassification Edit Transactions - Microsoft Internet Explorer

File Edit View Favorites Tools Help

Back Forward Stop Home Search Favorites

Address: https://qa.gwa.gov/GWAGovPartial224Web/reclassification.do?line_number=132162.0&theSelectedReclassRow=1&pgPage=1&reclassButtonAction=ShowReclassTransModify&action

GOVERNMENTWIDE ACCOUNTING & REPORTING **gwa** Modernization

HOME HELP LOG OFF

-- Go To -- Go

Welcome, Sheila Higgs 04/17/2007 08:13:03 AM EDT

Partial FMS 224

Online Interface System BulkFile Interface System

Home > Transactions > FMS Partial 224 Online

Current ALC: 20090003 - Rpt Month: 200703 - Rpt Type: Original

Reclassification	Payments	Collections	In Balance								
<table border="1"> <thead> <tr> <th>Appropriation, Fund or Receipt Account</th> <th>Entry Number</th> <th>Receipts and Collections Credited to Appropriation or Fund Accounts</th> <th>Gross Disbursements</th> </tr> </thead> <tbody> <tr> <td>0500107</td> <td>1</td> <td>46,489.66</td> <td>0.00</td> </tr> </tbody> </table>	Appropriation, Fund or Receipt Account	Entry Number	Receipts and Collections Credited to Appropriation or Fund Accounts	Gross Disbursements	0500107	1	46,489.66	0.00			
Appropriation, Fund or Receipt Account	Entry Number	Receipts and Collections Credited to Appropriation or Fund Accounts	Gross Disbursements								
0500107	1	46,489.66	0.00								

OK Cancel

Done Internet



Reclassification Delete

Sectional - Microsoft Internet Explorer

Address: https://qa.gwa.gov/GWAGovPartial24Web/reclassification.do?submit.action=apply

Current ALC: 20090003 - Rpt Month: 200703 - Rpt Type: Original

Reclassification Payments Collections Out of Balance

Search Criteria - 14 transactions met your criteria.

Account: --All-- Comparison: Equals

1 - 14 of 14 matches

Appropriation, Fund or Receipt Account	Entry Number	Receipts and Collections Credited to Appropriation or Fund Accounts	Gross Disbursements
0500107	1	(46,489.66)	0.00
0500107	2	0.00	(46,489.66)
0510107		489.66	0.00
0510107		489.66	0.00
0510107		0.00	46,489.66
0510107		0.00	(46,489.66)
0510107		0.00	46,489.66
053200		46,489.66	0.00
05900107	1	0.00	(46,489.66)
05X0107	1	(46,489.66)	0.00
05X0107	2	0.00	46,489.66
05X8022	1	(46,489.66)	0.00
05X8022	2	0.00	46,489.66
09X0110	1	0.00	(46,489.66)
Cumulative Subtotal:		(0.00)	0.00

1 - 14 of 14 matches

Net Total Section 1

Net Total(Disch.Pay) 0.00

Microsoft Internet Explorer Confirmation Please... Delete this Item? OK Cancel



Payments (Section 2)

The screenshot shows a web browser window titled "Sectional - Microsoft Internet Explorer" displaying the "Partial FMS 224 Online" interface. The address bar shows a URL for retrieving specific month details for ALC 20090003. The user is identified as Sheila Higgs, and the date is 04/17/2007. The interface includes a navigation menu with "Online Interface System" and "BulkFile Interface System". The main content area is titled "Current ALC: 20090003 - Rpt Month: 200703 - Rpt Type: Original". It features a left-hand tree view with a list of months from 08/2005 to 03/2007. The "Payments" tab is active, showing a summary table with the following data:

Reclassification	Payments	Collections	In Balance
1. Payments Transactions Accomplished			
This Month	0.00		
Prior Month (Total)+	0.00	=	
2. Collections Received This Month			
		=	
3. Net Total, Section 2			
		=	
4. Net Total, Section 1			
Prior Month	Amount		
Total:			

Below the table are buttons for "New...", "Modify...", and "Delete". The interface also includes links for "Text" and "CSV" exports.



Payments New

The screenshot shows a Microsoft Internet Explorer browser window titled "Prior Months Edit Transactions". The address bar contains the URL: https://qa.gwa.gov/GWAGovPartial224Web/payments.do?current_disb_frm=0.00&theSelectedPaymentsRow=0&paymentsactionConfirmed=notValid&paymentsButton4. The page header includes the GWA Modernization logo, a "HOME HELP LOG OFF" menu, a "Go To" search box, and a timestamp: "04/17/2007 08:20:01 AM EDT".

The main content area is titled "Partial FMS 224" and "Online Interface System". It shows a breadcrumb trail: "Home > Transactions > FMS Partial 224 Online". The current ALC is "20090003", the report month is "200703", and the report type is "Original".

On the left, a list of months with star icons is displayed, with "03/2007" selected. The main table has columns for "Reclassification", "Payments", "Collections", and "In Balance". The "Payments" column contains a form for editing a payment entry:

Prior Month	Amount
MM	YYYY
01	1980
0.00	

Buttons for "Ok" and "Cancel" are located below the form.



Payments Modify

Prior Months Edit Transactions - Microsoft Internet Explorer

File Edit View Favorites Tools Help

Back Forward Stop Home Search Favorites Refresh Print Mail Stop

Address https://qa.gwa.gov/GWAGovPartial224Web/payments.do?current_disb_frm=0.00&theSelectedPaymentsRow=1&paymentsactionConfirmed=notValid&paymentsButton4 Go

GOVERNMENTWIDE ACCOUNTING & REPORTING **gwa** Modernization

HOME HELP LOG OFF

-- Go To -- Go

Welcome, Sheila Higgs 04/17/2007 08:20:58 AM EDT

Partial FMS 224

Online Interface System BulkFile Interface System

Home > Transactions > FMS Partial 224 Online

Current ALC: 20090003 - Rpt Month: 200703 - Rpt Type: Original

Reclassification Payments Collections Out of Balance

MM Prior Month YYYY Amount

01 1980 10.00

Ok Cancel

20090003

- 03/2007
- 02/2007
- 01/2007
- 12/2006
- 10/2006
- 09/2006
- 08/2006
- 06/2006
- 05/2006
- 04/2006
- 02/2006
- 01/2006
- 12/2005
- 11/2005
- 10/2005

Done Internet



Payments Delete

The screenshot shows a Microsoft Internet Explorer browser window displaying a web application. The address bar shows a URL from qa.gwa.gov. The page title is 'Sectional - Microsoft Internet Explorer'. The application interface includes a navigation menu with 'Online Interface System' and 'BulkFile Interface System'. The main content area is titled 'FMS Partial 224 Online' and shows a 'Payments' tab. A confirmation dialog box is overlaid on the page, asking 'Confirmation Please... Delete this Item?' with 'OK' and 'Cancel' buttons. The background interface shows a summary table for payments.

Prior Month	Amount
01/1980	10.00
Total:	10.00



Collections (Section 3)

Sectional - Microsoft Internet Explorer

File Edit View Favorites Tools Help

Back Forward Stop Refresh Home Search Favorites

Address: https://qa.gwa.gov/GWAGovPartial224Web/alCDetails.do?submit.action=retrieve.specificMonth&alc=20091800&rpt_Month=200703&rpt_Type_Code=0&transmit_Ind=N Go

GOVERNMENTWIDE ACCOUNTING & REPORTING **gwa** Modernization

HOME HELP LOG OFF

-- Go To -- Go

Welcome, Sheila Higgs 04/18/2007 02:52:02 PM EDT

Partial FMS 224

Online Interface System BulkFile Interface System

Home > Transactions > FMS Partial 224 Online

Current ALC: 20091800 - Rpt Month: 200703 - Rpt Type: Original

Reclassification	Payments	Collections	In Balance
1. Balance of Undeposited Collections, Text CSV			
Close of Preceding Month	0.00		
2. Collections Received This Month			0.00
3. Deposits Presented or Mailed to Bank			
This Month	<input type="text" value="0.00"/>		
Prior Month (Total) +	0.00	=/	0.00
4. Net Total, Section 3			
			0.00
Prior Month	Amount		
Total:			0.00

New... Modify... Delete

Internet



Collections New

The screenshot shows a Microsoft Internet Explorer browser window displaying the GWA Modernization web application. The browser title is "Prior Months Edit Transactions - Microsoft Internet Explorer". The address bar shows the URL: https://qa.gwa.gov/GWAGovPartial224Web/collections.do?current_collections_frm=0.00&theSelectedCollectionsRow=0&collectionsactionConfirmed=notValid&updateOr

The application header includes the GWA Modernization logo, a "Welcome, Sheila Higgs" message, and the date "04/17/2007 08:27:48 AM EDT". Navigation buttons for "HOME", "HELP", and "LOG OFF" are present, along with a "Go To" search field.

The main content area is titled "Partial FMS 224" and "Online Interface System". It shows a breadcrumb trail: "Home > Transactions > FMS Partial 224 Online". The current ALC is "20092800", the Rpt Month is "200703", and the Rpt Type is "Original".

The "Collections" tab is active, displaying a table with columns for "Reclassification", "Payments", "Collections", and "In Balance". The table has a sub-header for "Prior Month" (MM) and "Amount" (YYYY). The current selection is "02" for the month and "1980" for the year, with an amount of "0.00".

On the left side, there is a tree view showing a list of transactions and months:

- 20090003
- 20090700
- 20090800
- 20090900
- 20091700
- 20091800
- 20091900
- 20092800
 - 03/2007
 - ★ 02/2007
 - ★ 01/2007
 - ★ 12/2006
 - ★ 10/2006
 - ★ 09/2006
 - ★ 08/2006
 - ★ 06/2006



Collections Delete

The screenshot shows a Microsoft Internet Explorer browser window displaying a web application. The address bar shows the URL: https://qa.gwa.gov/GWAGovPartial224Web/collections.do?current_collections_frm=0.00&theSelectedCollectionsRow=1&collectionsactionConfirmed=false&updateOrInsert=&collecti

The application header includes the GWA Modernization logo, a user greeting "Welcome, Sheila Higgs", and the date "04/17/2007 08:30:38 AM EDT". Navigation buttons for "HOME", "HELP", and "LOG OFF" are present.

The main content area is titled "Partial FMS 224" and "Online Interface System". The current view is "FMS Partial 224 Online" with "Current ALC: 20092800" and "Rpt Month: 200703". The "Collections" tab is active, showing a table with the following data:

Reclassification	Payments	Collections	Out of Balance
1. Balance of Undeposited Collections			
Close of Preceding Month			0.00
2. Collections Received This Month			
3. Deposits Presented or Mailed This Month			
Prior Month (Total) +	10.00	=/	10.00
4. Net Total, Section 3			(10.00)

A confirmation dialog box titled "Microsoft Internet Explorer" is overlaid on the table, asking "Confirmation Please... Delete this Item?" with "OK" and "Cancel" buttons.

Below the table, there are buttons for "New...", "Modify...", and "Delete".



Information Tab

Sectional - Microsoft Internet Explorer

File Edit View Favorites Tools Help

Address https://qa.gwa.gov/GWAGovPartial224Web/aLCDetails.do?submit.action=retrieve.specificMonth&alc=20096500&rpt_Month=200703&rpt_Type_Code=0&transmit_Ind=N Go

Welcome, Sheila Higgs 04/18/2007 01:34:35 PM EDT

Partial FMS 224

Online Interface System BulkFile Interface System

Home > Transactions > FMS Partial 224 Online

Current ALC: **20096500** - Rpt Month: **200703** - Rpt Type: **Original**

Reclassification	Payments	Collections	In Balance
This Statement currently is In Balance:			
Current ALC:	20096500		
Rpt Month:	200703		
Rpt Type:	Original		
224 Transmit Date:			
CAFE Transmit Date:			
Net Total, Section 1:	0.00		
Net Total, Section 2:	0.00		
Net Total, Section 3:	0.00		
Process Method:	Online		
User Id:	P224Prepare27		
Role:	P224P		
Access Id:	1626		
Participation Indicator:	4 - Reports Reclassification, Payments, and Collection transactions.		
P224 Application Status:	The System is currently activated - allowing UPDATE access to authorized users		
P224 Application Version:	p224_v2r3b0_20061023_2		



Download Function

The screenshot shows a Microsoft Internet Explorer browser window displaying a financial reporting application. A 'File Download' dialog box is open in the center, asking 'Do you want to open or save this file?'. The dialog provides the following information:

- Name: ...224_P224Preparer27_1677350394_20090003.txt
- Type: Text Document, 1.94 KB
- From: qa.gwa.gov

Buttons for 'Open', 'Save', and 'Cancel' are visible. Below the dialog, a warning icon and text state: 'While files from the Internet can be useful, some files can potentially harm your computer. If you do not trust the source, do not open or save this file. [What's the risk?](#)'

The background interface includes a navigation menu with 'Home', 'Transactions', and 'FMS Partial 224 Online'. A table of transactions is visible, with columns for 'Appropriation, Fund or Receipt Account', 'Quantity', and 'Amount'. The table contains several rows of data, including entries for account 0500107 and 053200.

The browser's address bar shows the URL: https://qa.gwa.gov/GWAGovPartial224Web/collections.do?current_collections_fmt=0.00&theSelectedCollectionsRow=1&collectionsactionConfirmed=true&updateOrInsert=&collectic

The status bar at the bottom indicates: 'Downloading from site: <https://qa.gwa.gov/GWAGovPartial224Web/p224DataDownload.do?submit.action=sect18format=Text&salc=200900038>'



Print P224 Report

STATEMENT OF TRANSACTIONS			
(Classified According to Appropriation, Fund and Receipt Account, and Related Control Totals)			
(Transmitted to Cafe on 07-15-2005)			
DEPARTMENT OR AGENCY ARCHITECT OF THE CAPITOL	LOCATION - MAIL ADDRESS OF REPORTING OFFICE ACCOUNTING SECTION UNITED STATES CAPITOL WASHINGTON, DC	AGENCY STATION (8 digit) SYMBOL 20040001	
BUREAU OR OFFICE LEGISLATIVE ESTABLISHMENT		ACCOUNTING PERIOD 200507 Original	
Section I - Classification of Disbursements and Collections by Appropriation, Fund and Receipt Amount			
Appropriation, Fund or Receipt Account	Entry Number	Receipts and Collections Credited to Appropriation or Fund Accounts	Gross Disbursements
Cumulative Subtotal:		0.00	0.00
		Net Total, Section 1 Net Total(Disb-Rec)	0.00
Section II - Control Totals of Disbursements and Collections Classified in Section I			
1. Payments Transactions Accomplished			
This Month	<input style="width: 100px;" type="text" value="0.00"/>		
Prior Month (Total) +	0.00	=	0.00
2. Collections Received This Month			
Month		-	<input style="width: 100px;" type="text" value="0.00"/>
3. Net Total, Section 2			
		=	0.00
Prior Month		Amount	
		Total:	0.00
Section III - Status of Collections			
1. Balance of Undeposited Collections, Close of Preceding Month 0.00			
2. Collections Received This Month			
0.00			
3. Deposits Presented or Mailed to Bank			
This Month	<input style="width: 100px;" type="text" value="0.00"/>		
Prior Month (Total) +	0.00	=-	0.00
4. Net Total, Section 3			
0.00			
Prior Month		Amount	
		Total:	0.00
DATE	NOTE: Required to be transmitted by the third working day following the close of the reporting month.		SIGNATURE AND TITLE



Transmit Screen

The screenshot shows a Microsoft Internet Explorer browser window displaying the GWA Modernization web application. The browser address bar shows the URL: https://qa.gwa.gov/GWAGovPartial224Web/collections.do?current_collections_fmt=0.00&theSelectedCollectionsRow=1&collectionsactionConfirmed=true&updateOrInsert=&collectic

The application header includes the GWA Modernization logo, navigation buttons (HOME, HELP, LOG OFF), a search bar, and a welcome message: "Welcome, Sheila Higgs". The date and time are displayed as "04/17/2007 08:40:59 AM EDT".

The main content area shows the "Partial FMS 224" interface. The current ALC is "20090003" and the Rpt Month is "200703". The Rpt Type is "Original". The interface is divided into tabs: "Reclassification", "Payments", "Collections", and "In Balance".

A search criteria dialog box is open, displaying "Search Criteria - 14 transactions met your criteria." and "Account: --All-- Comparison: Equals". Below this, a table lists 14 transactions with columns for "Appropriation, Fund or Receipt Account", "Payments", "Collections", and "In Balance".

Appropriation, Fund or Receipt Account	Payments	Collections	In Balance
0500107			0.00
0500107			(46,489.66)
0510107			0.00
0510107	2	46,489.66	0.00
0510107	3	0.00	46,489.66
0510107	4	0.00	(46,489.66)
0510107	5	0.00	46,489.66
053200	1	46,489.66	0.00
05900107	1	0.00	(46,489.66)
05X0107	1	(46,489.66)	0.00

A confirmation dialog box from Microsoft Internet Explorer is overlaid on the table, with the text: "Confirmation Please... Transmit this item to CAFE?..." and "OK" and "Cancel" buttons.



P224 Bulk Interface System

Bulk Interface System

The screenshot shows a web browser window titled "P224 Bulk - Microsoft Internet Explorer". The address bar contains the URL: https://qa.gwa.gov/GWAGovPartial224Web/collections.do?current_collections_fmt=0.00&theSelectedCollectionsRow=1&collectionsactionConfirmed=true&updateOrInsert=&collectic. The page header includes the "gwa Modernization" logo, navigation links for "HOME", "HELP", and "LOG OFF", a search bar, and a "Go" button. A welcome message reads "Welcome, Sheila Higgs" with a timestamp of "04/17/2007 08:43:22 AM EDT". The main content area features a breadcrumb trail: "Home > Transactions > FMS Partial 224 Bulk". Below this, there are three tabs: "Input Data File", "Input Info", and "Results". The "Input Data File" tab is active, showing a "Select file to upload:" label, a text input field, a "Browse..." button, and a "Submit" button. At the bottom of the page, there are links for "Accessibility", "Contacts", and "Privacy Policy", and a footer for "U. S. Department of the Treasury - Financial Management Service".



Input Data File

Partial FMS 224

Online Interface System > BulkFile Interface System

Home > Transactions > FMS Partial 224 Bulk

Input Data File | Input Info | Results

Select file to upload:

Report Month	Uploaded File Name	File Size	Run Attempts	Error Count	Input File RunTimes
03/07	/apps/data/p224/tmp/Bulk File_Prod_good_file_2800.bt	1280 bytes	4	0	4/17/2007 8:57:21 4/17/2007 8:55:49 4/17/2007 8:54:08

Accessibility | [Contacts](#) | [Privacy Policy](#)

U. S. Department of the Treasury - Financial Management Service



Input Info Screen

P224 Bulk - Microsoft Internet Explorer 4/17/07 9:03:57 AM S W R B C D

File Edit View Favorites Tools Help

Back Forward Stop Refresh Home Search Favorites

Address https://qa.gwa.gov/GWAGovPartial224Web/collections.do?current_collections_frm=0.00&theSelectedCollectionsRow=1&collectionsactionConfirmed=true&updateOrInse Go

GOVERNMENTWIDE ACCOUNTING & REPORTING **gwa** Modernization

HOME HELP LOG OFF

-- Go To -- Go

Welcome, Sheila Higgs 04/17/2007 09:57:22 AM EDT

Partial FMS 224

Online Interface System BulkFile Interface System

Home > Transactions > FMS Partial 224 Bulk

Input Data File **Input Info** Results

Input Transactions - 22 [Text](#) [CSV](#)

1 - 15 of 22 matches << Previous 15 Next 15 >> Page 1 2

Line Number	Record Type	Number	ALC	Approp Number	Entry Number	Amount	Transaction Date	Reporting Date
1	01	0	20092800	20F3875.18	01	46,489.66		03/2007
2	01	0	20092800	20X1807	01	4,855.44		03/2007
3	01	0	20092800	20F3875.18	01	338.58		03/2007
4	01	0	20092800	20X1807	01	169,899.98		03/2007
5	01	0	20092800	20X1807	01	2,337.43		03/2007
6	01	0	20092800	20X1807	01	91,393.33		03/2007
7	02	0	20092800	20F3875.18	01	3,120,360.04		03/2007
8	02	0	20092800	20F3875.18	01	2,038,040.40		03/2007
9	02	0	20092800	20F3875.18	01	10,366.92		03/2007
10	02	0	20092800	20F3875.18	01	(4,487.72)		03/2007
11	02	0	20092800	20F3875.18	01	14,277.68		03/2007
12	02	0	20092800	20F3875.18	01	48,484.13		03/2007

Internet



Results

The screenshot shows a Microsoft Internet Explorer browser window displaying the GWA Modernization web application. The address bar shows the URL: https://qa.gwa.gov/GWAGovPartial224Web/collections.do?current_collections_frm=0.00&theSelectedCollectionsRow=1&collectionsactionConfirmed=true&updateOrInsert=&colle

The page header includes the GWA Modernization logo, navigation links (HOME, HELP, LOG OFF), a search bar, and a welcome message: "Welcome, Sheila Higgs" with the timestamp "04/17/2007 09:20:37 AM EDT".

The main content area shows the "Partial FMS 224" interface with tabs for "Input Data File", "Input Info", and "Results". The "Results" tab is active, displaying "Error Count - 3" and "1 - 3 of 3 matches".

Error Count	Error Messages
1	Error on line 18 Record Type 14, at column positions (1:2), cannot report in Section 3 (Participation Indicator 3).
2	Error on line 19 Record Type 15, at column positions (1:2), cannot report in Section 3 (Participation Indicator 3).
3	Error on line 20 Record Type 26, at column positions (1:2), cannot report in Section 3 Net Total (Participation Indicator 3).

At the bottom of the page, there are links for "Accessibility", "Contacts", and "Privacy Policy", and a footer for "U. S. Department of the Treasury - Financial Management Service".



Error Message Description

P224 Bulk - Microsoft Internet Explorer

File Edit View Favorites Tools Help

Back Forward Stop Refresh Home Search Favorites

Address https://qa.gwa.gov/GWAGovPartial224Web/collections.do?current_collections_frm=0.00&theSelectedCollectionsRow=1&collectionsactionConfirmed=true&updateOrInsert=&colle

GOVERNMENTWIDE ACCOUNTING & REPORTING
gwa
Modernization

HOME HELP LOG OFF

-- Go To -- Go

Welcome, Sheila Higgs 04/17/2007 09:21:24 AM EDT

Partial FMS 224

Online Interface System Bulk File Interface System

Home > Transactions > FMS Partial 224 Bulk

Input Data File Input Info Results

Input Transactions - 22 [Text](#) [CSV](#)

16 - 22 of 22 matches [Previous 15](#) Next 15 Page 1 2

Line Number	Record Type	Number	ALC	Approp Number	Entry Number	Amount	Transaction Date	Reporting Date
16	04	0	20090003			1,450.66	10/00	03/2007
17	05	0	20090003			389,566.50	09/00	03/2007
18	14	0	20090003			286,047.48		03/2007
19	15	0	20090003			286,047.48		03/2007
20	26	0	20090003			0.00		03/2007
21	98	Total	Entries	For ALC 20090003	Is Equal to 20			
22	99	Total	ALC Entries	On file	Is Equal to 20			

16 - 22 of 22 matches [Previous 15](#) Next 15 Page 1 2

[Accessibility](#) | [Contacts](#) | [Privacy Policy](#)

U. S. Department of the Treasury - Financial Management Service

Done Internet



GOVERNMENTWIDE
ACCOUNTING & REPORTING

gwa

Modernization



PAYMENTS

GWAMP Day: Policy Impacts and System Changes

April 25, 2007

Collections

TAS/BETC or
C-Key

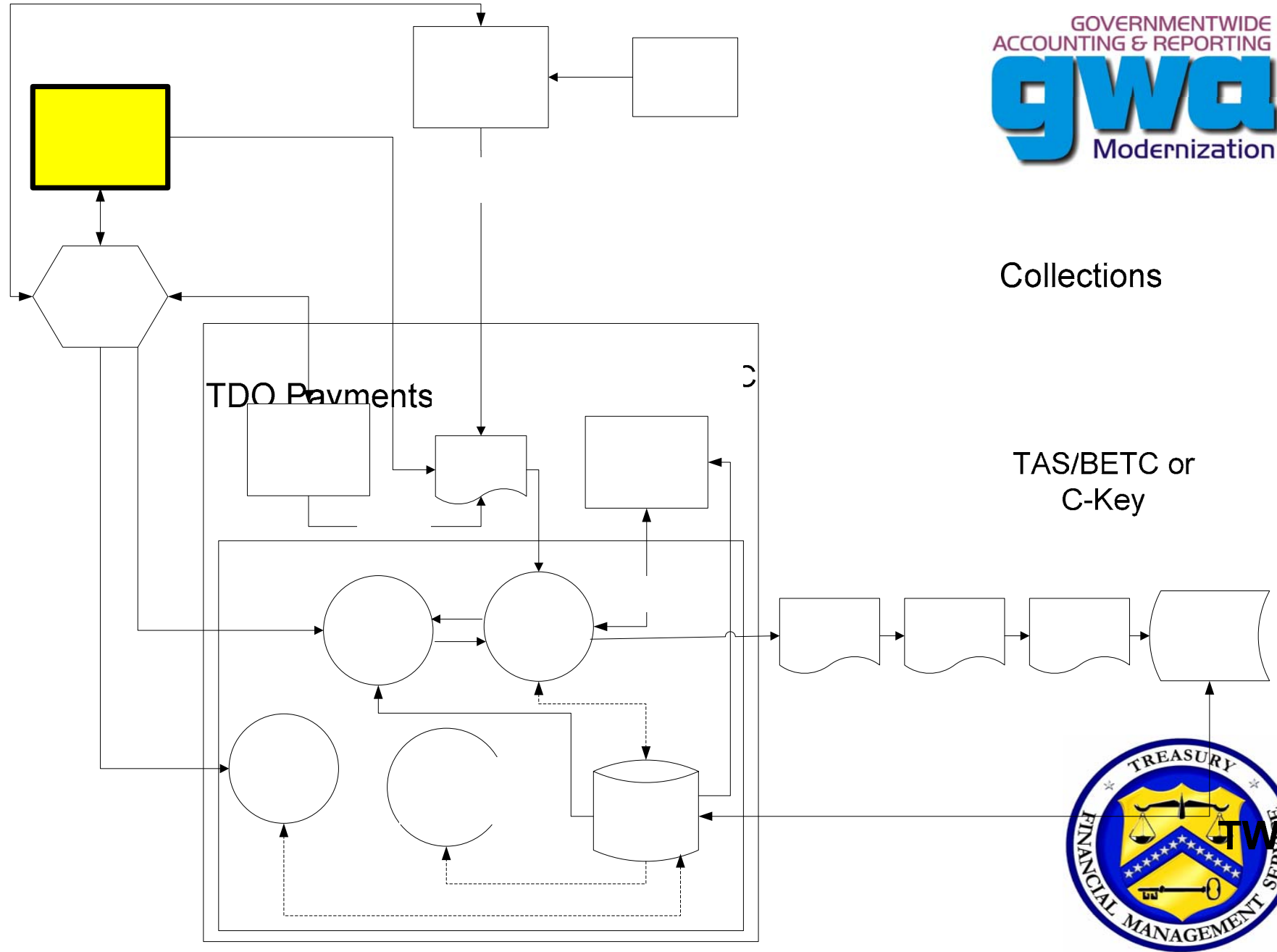

Identified Pilots

- USDA
- Bureau of Prisons
- Denali Commission
- TOP Control System (TCS)
- SSI
- Federal Energy Regulatory Commission



Payments (Current)

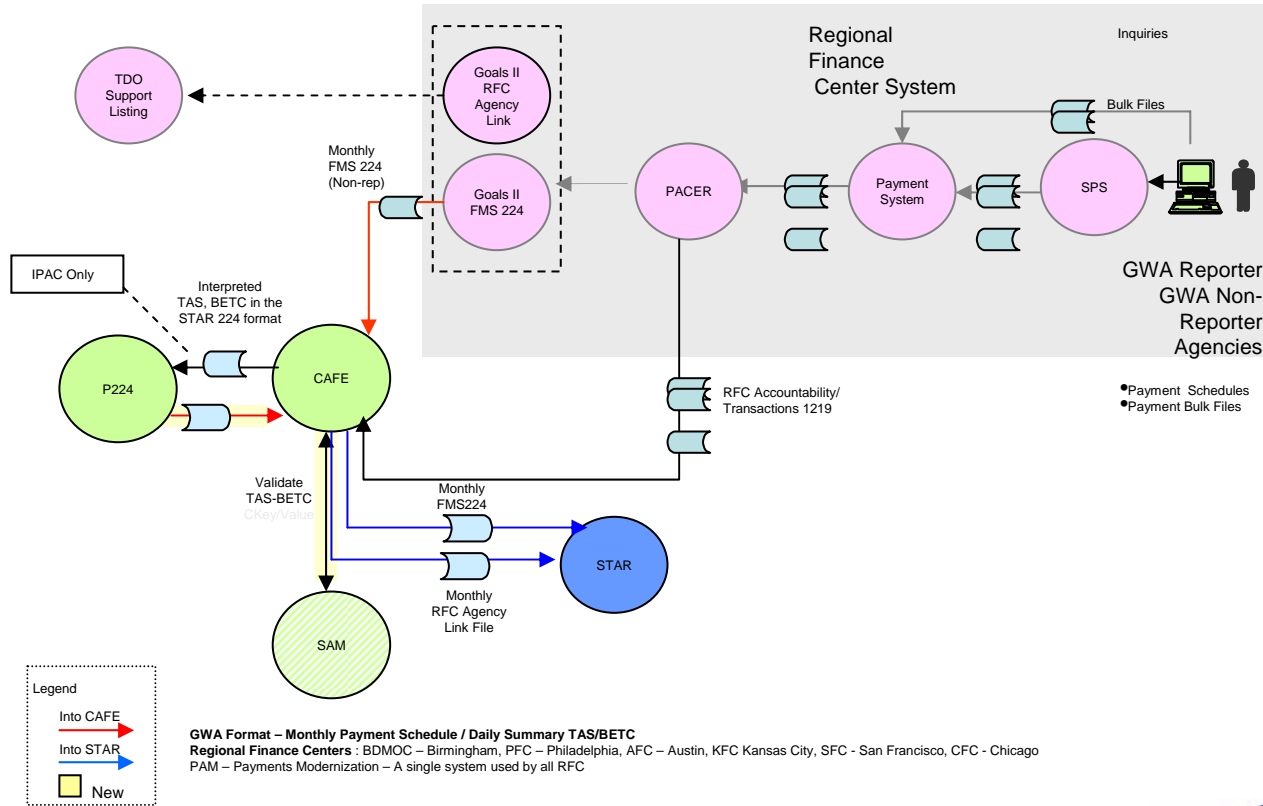

Payments (Future)

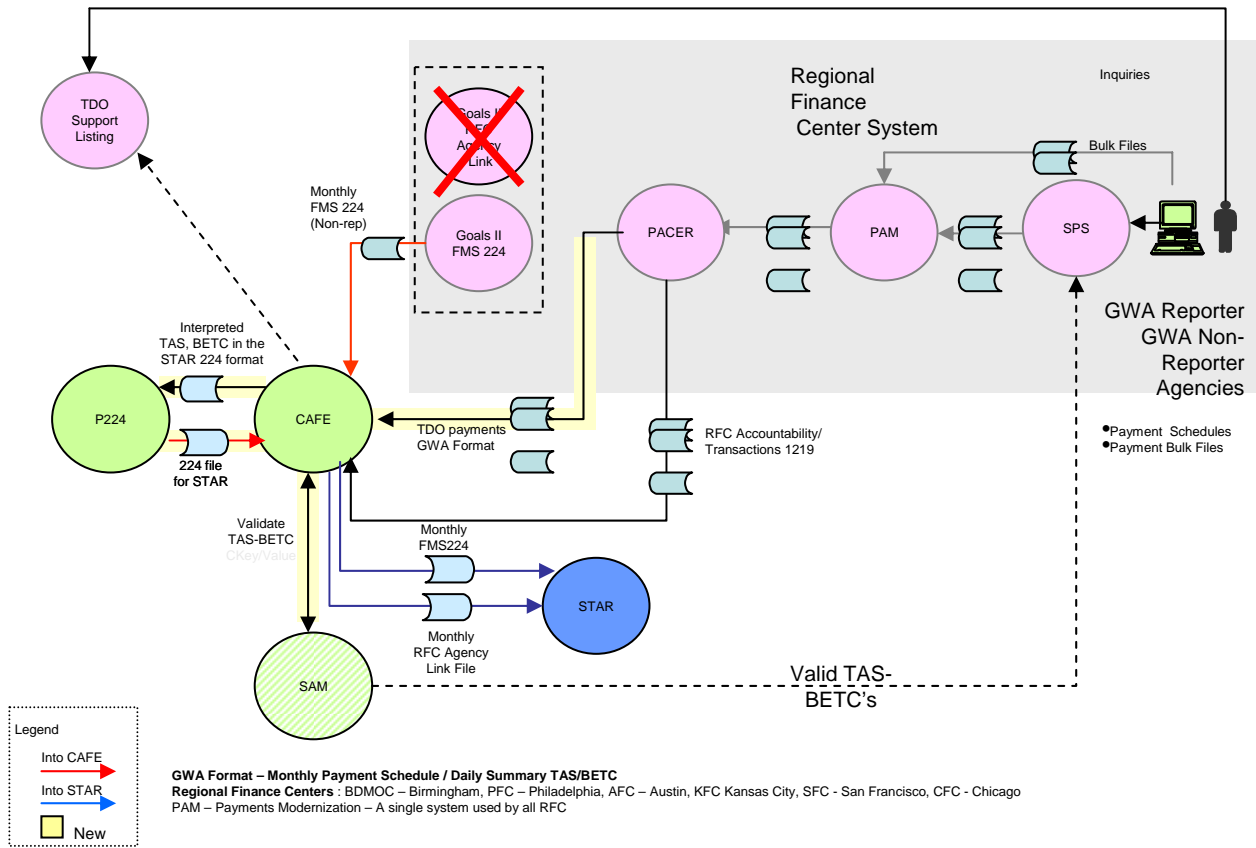

Roll Out Schedule

- Payment Pilot Phase - July 2007
- New Bulk Formats – August 2007
- SSI Pilot – Mid – 2008
- System modifications completed - 2009



GOVERNMENTWIDE
ACCOUNTING & REPORTING

gwa
Modernization



COLLECTIONS AND THE TRANSACTION REPORTING SYSTEM (TRS)

GWAMP Day: Policy Impacts and System Changes

April 25, 2007

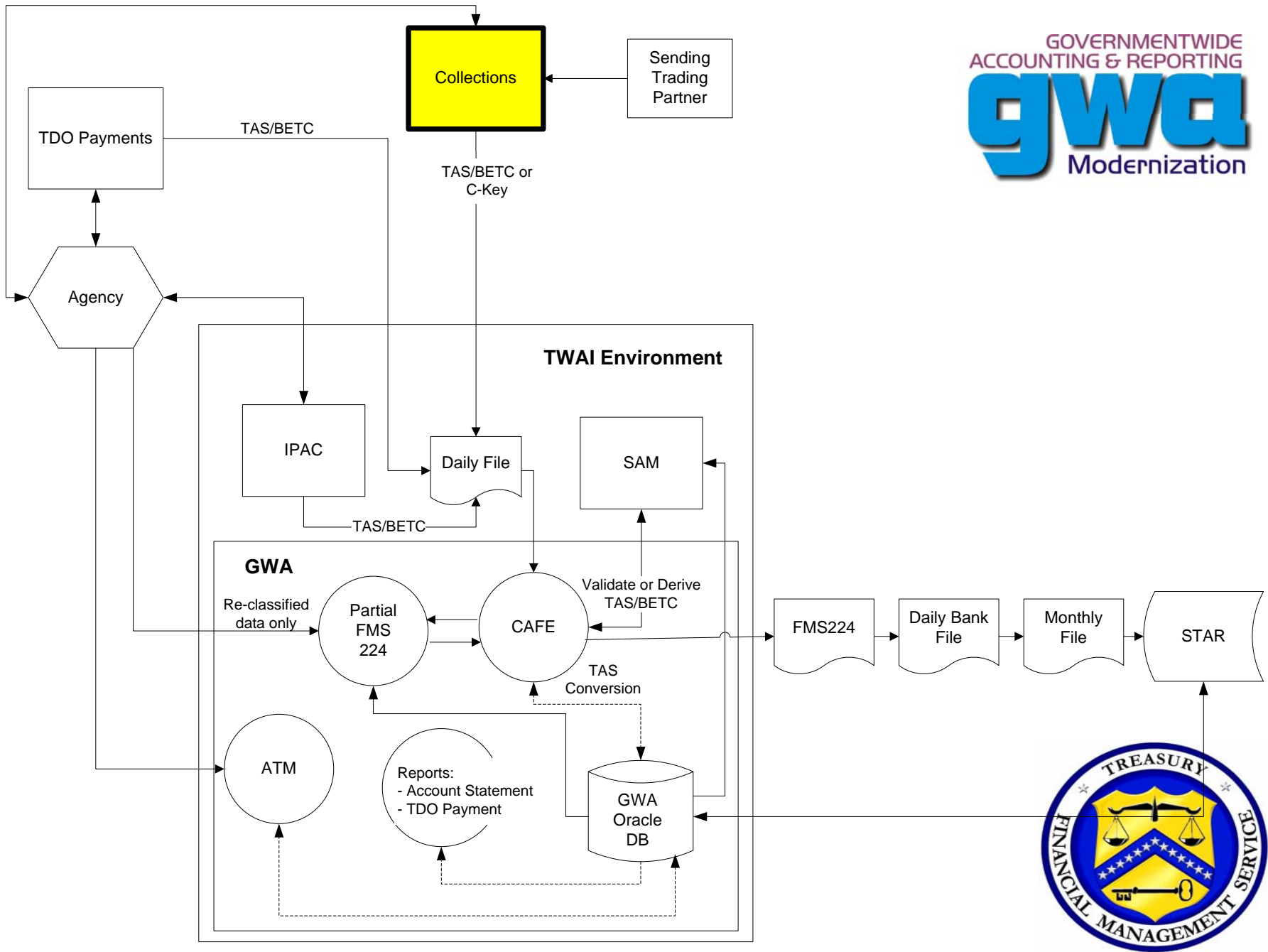

Changes underway in the Collections area:

- **Transaction reporting for receipts will centralize in TRS**
- **Deposit reporting will migrate from CA\$HLINK II to TRS**
- **Over-the-Counter deposits will migrate fully to TGAnet**
- **Current CA\$HLINK summary deposit reports (SF 215) will evolve to an integrated transaction and deposit report in TRS**
- **This will include GWA-ready subtotals by TAS/BETC (where available) or Classification Key (C-Key)**

What does this mean?

Example 1: Over the Counter receipts

A hypothetical agency field office with an ALC of 99010001 receives collections today as follows:

- License Fees (Pgm Code 50): Cash and checks totaling \$2,000**
- Fines (Pgm Code 70): Cash and checks totaling \$6,000**
- Merchandise Sales (Pgm Code 90): Cash and checks totaling \$ 1,000**

Example 1: Over the Counter receipts

The agency will prepare an electronic deposit in TGA net something like this:

Deposit # 123456 ALC: 99010001 Date: 04/25/2007

Total Deposit: \$9,000

<u>Pgm Code</u>	<u>Amount</u>
50	\$2,000
70	\$6,000
90	\$1,000

GWAMP Day - April 25, 2007





Example 1: Over the Counter receipts

- **TGAnet sends this information to TRS**
- **TRS forwards all deposit information to GWA daily**



Example 1: Over the Counter receipts

Users for ALC 99010001 will have established a Cash Flow Profile in SAM for Over the Counter receipts:

C-Key Name: Pgm Code

<u>CKey Value</u>	<u>Dr/Cr</u>	<u>TAS</u>	<u>BETC</u>	<u>%</u>
50	Cr	99 5678	UNAVRCT	100
50	Dr	99 5678	UNAVRADJ	100
70	Cr	99 2345	UNAVRCT	100
70	Dr	99 2345	UNAVRADJ	100

Example 1: Over the Counter receipts

ALC 99010001 – SAM Cash Flow Profile for Over the Counter receipts (continued):

- C-Key Name: Pgm Code

<u>CKey Value</u>	<u>Dr/Cr</u>	<u>TAS</u>	<u>BETC</u>	<u>%</u>
90	Cr	99X4003	COLL	100
90	Dr	99X4003	COLLADJ	100

Example 1: Over the Counter receipts

When TRS sends the TGA net data to GWA, SAM will translate the “Pgm Codes” as follows:

Deposit # 123456 ALC: 99010001 Date: 04/25/2007
Total Deposit: \$9,000

<u>TAS</u>	<u>BETC</u>	<u>Amount</u>
99 5678	UNAVRCT	\$2,000
99 2345	UNAVRCT	\$6,000
99X4003	COLL	\$1,000

Example 2: Lockbox receipts

The same ALC has established Lockbox Account 678594 for merchandise sales. Today it receives 200 checks in that Account as follows:

<u>Check Number</u>	<u>Date</u>	<u>Amount</u>
3458	04/23/07	\$ 100
3536	04/23/07	\$ 50
3678	04/22/07	\$ 210
<Etc....>	<Etc....>	<Etc....>
	Total	\$30,000

GWAMP Day - April 25, 2007



Example 2: Lockbox receipts

ALC 99010001 will have established a SAM Cash Flow Profile for Lockbox receipts as follows:

C-Key Name: Lockbox Account

<u>CKey Value</u>	<u>Dr/Cr</u>	<u>TAS</u>	<u>BETC</u>	<u>%</u>
678594	Cr	99X4003	COLL	100
678594	Dr	99X4003	COLLADJ	100

Example 2: Lockbox receipts

TRS will receive the detailed check information and prepare an electronic deposit something like this:

Deposit # 233243 ALC: 99010001 Date: 04/25/2007

Total Deposit: \$30,000

<u>Lockbox Account</u>	<u>Amount</u>
678594	\$30,000

Example 2: Lockbox receipts

When TRS sends the lockbox data to GWA, SAM will translate the “Lockbox Account” as follows:

Deposit # 233243 ALC: 99010001 Date: 04/25/2007
Total Deposit: \$30,000

<u>TAS</u>	<u>BETC</u>	<u>Amount</u>
99X4003	COLL	\$30,000

Food for Thought

Design of TRS deposit reports has not begun, but here is a possible scenario for viewing this data in TRS

ALC: 99010001 Date: 04/25/2007 Total Deposits: \$39,000

<u>Deposit #</u>	<u>Amount</u>	<u>Collection Mech</u>	<u>Details</u>
123456	\$ 9,000	TGA	<link>
233243	\$30,000	Lockbox	<link>

What can agencies do NOW to get ready?

- **Identify individuals to work with us to define C-Keys and Cash Flow Profiles in SAM**
- **Provide C-Key/Cash Flow Profile data to the SAM Conversion Team – a partnership between FMS and FRB St Louis**
- **Identify and establish agency SAM users**
- **Maintain Cash Flow Profile data in SAM**

*Current target: gather all Collections Cash Flow data by the end of
CY 2007*

GWAMP Day - April 25, 2007



Contacts

SAM

Cheryl Murray (FMS) – Phone: 202-874-7078

Email: Cheryl.Murray@fms.treas.gov

Nicole Kull (FRB STLS) – Phone: 314-444-4621

Email: Nicole.Kull@stls.frb.org

TRRS and General Questions

Fred Lehnhoff (FMS) – Phone: 202-874-3327

Email: Fred.Lehnhoff@fms.treas.gov

GWAMP Day - April 25, 2007



GOVERNMENTWIDE
ACCOUNTING & REPORTING

gwa
Modernization



TDO PAYMENT SUPPORT

GWAMP Day: Policy Impacts and System Changes

April 25, 2007

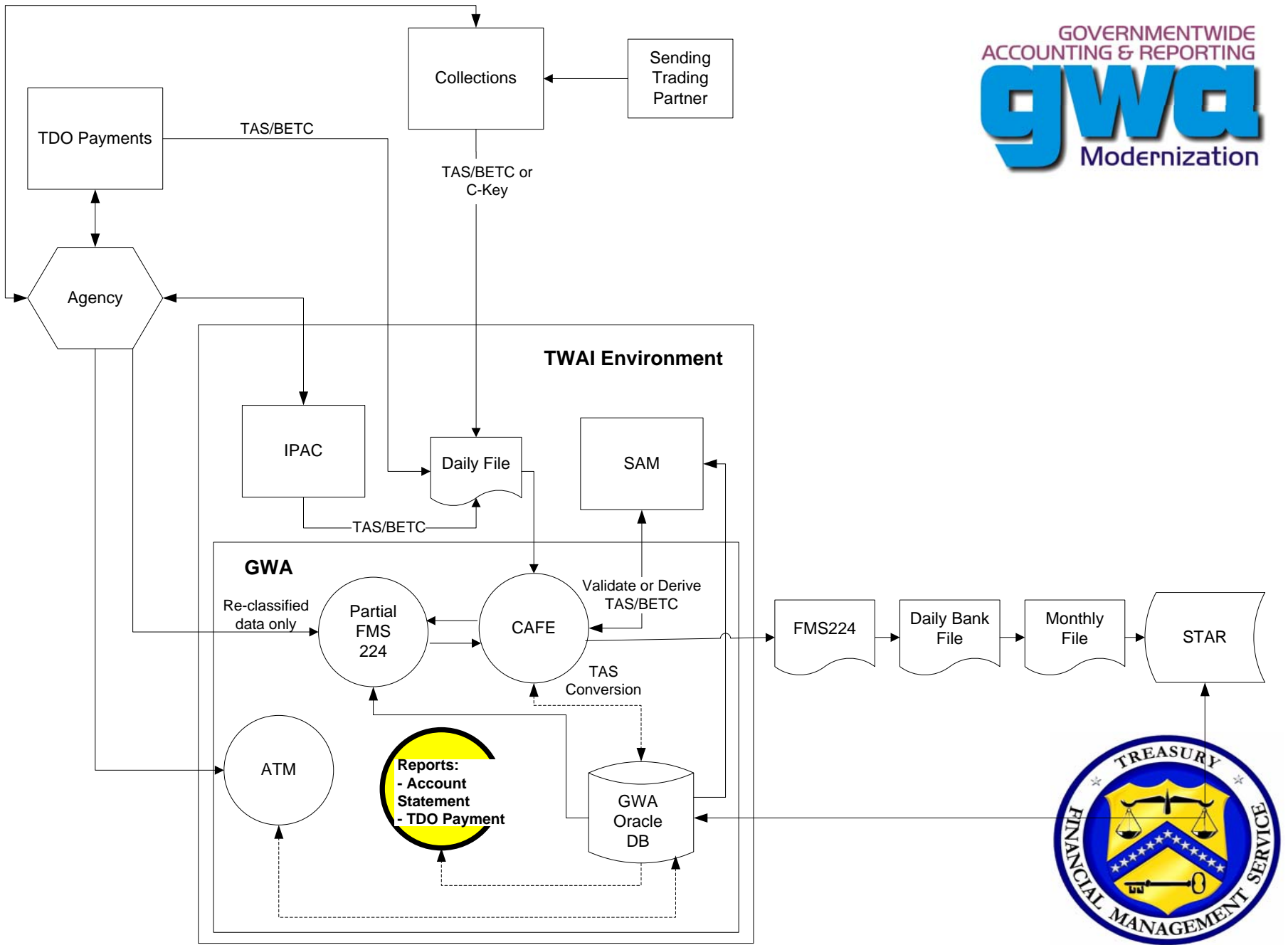

TDO Payment Support Data Flow

TDO Payment Inquiries

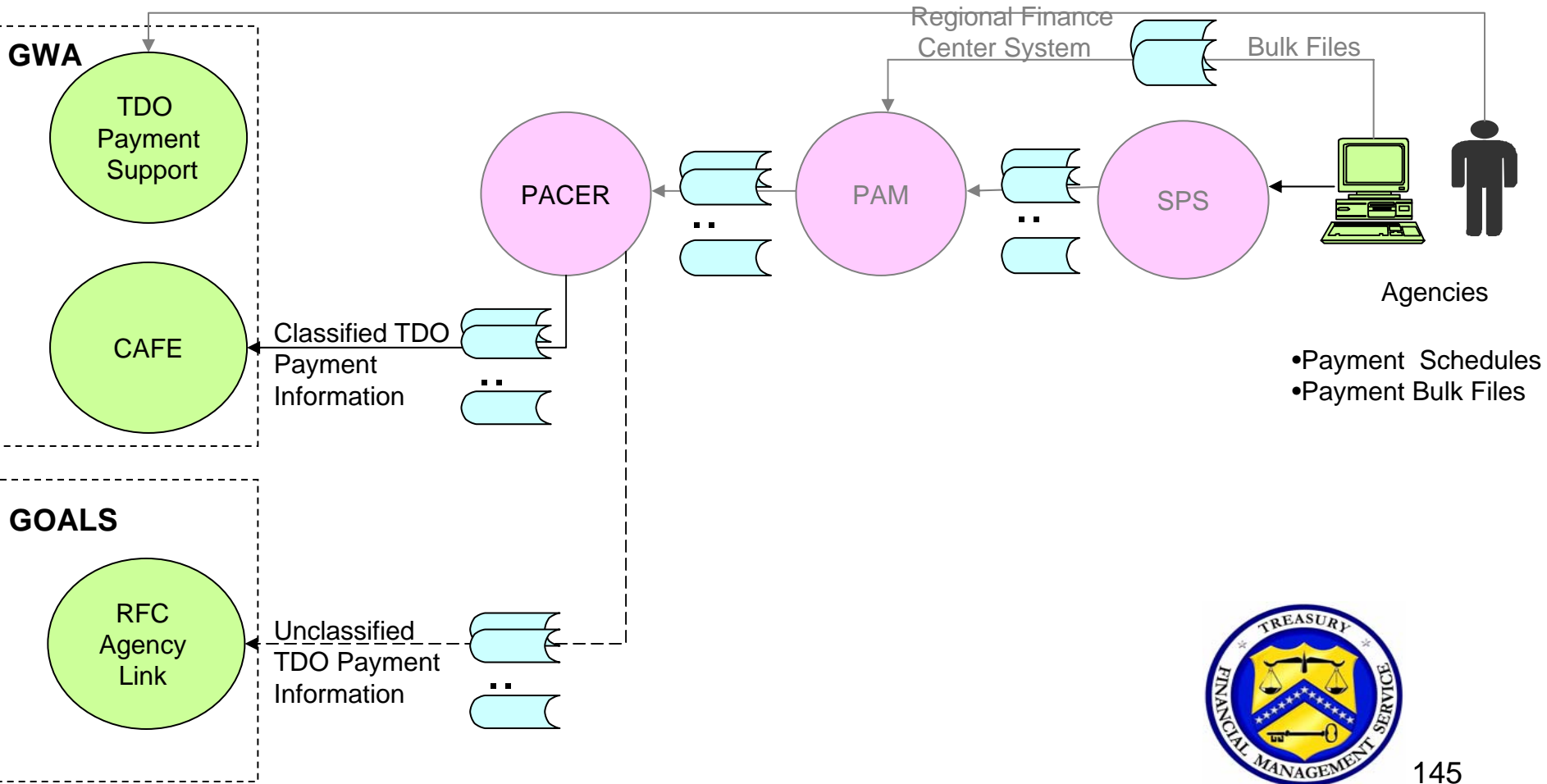

Transition from RFC Agency Link to TDO Payment Support

- **June 30, 2007** – FMS/GWA System will introduce the GWA Treasury Disbursing Office (TDO) Payments Support Reporting Module
- **Through September 30, 2007** - Existing RFC Agency Link Application will continue to provide **daily** payment information
- **Through December 31, 2007** - Existing RFC Agency Link Application will continue to provide **historical** payment information



Enrollment for TDO Payment Support

gwa GOVERNMENTWIDE
ACCOUNTING SYSTEM

Logon

Logon

User ID:

Password:

[Enroll](#) [Forgot Password](#)

WARNING! You are using an official United States Government System, which may be used only for authorized purposes. Unauthorized use or modification of any information on this system is a violation of federal law and may subject you to civil and criminal penalties. The Government may monitor and audit the usage of this system, and all persons are hereby notified that the use of this system constitutes consent to such monitoring and auditing.

[Accessibility](#) | [Contacts](#) | [Privacy Policy](#)

U. S. Department of the Treasury - Financial Management Service

- Users may request access to TDO Payments by visiting the GWA Website (<http://fms.treas.gov/gwa/index.html>) and clicking on Enrollment or clicking on "enroll" located on the GWA system logon page (<https://www.gwa.gov>).
- GWA System users will be required to select the enrollment option and have their request routed to their supervisor for approval.
- **Note:** Employees will not be able to enroll or make modifications to their access unless their supervisor is already enrolled.



RFC Agency Link – Agency Confirmation Report

Agency Confirmation Report –
Schedule Highest to lowest within Confirmed Date lowest to highest

GOALS II Information Access System Site Map | Help **LOG OFF**
 Welcome Super User Logged-On: 3/7/2007 11:11:38 AM ET

Home Fund Account Agency Location Code Agency Reporting Special Functions User Guide FMS Applications

Agency Location Code: [Statement-of-Differences](#) | [RFC Agency Link](#)

Agency Location Code: 47000016
 Report: ACR--Schedule (highest to lowest) within Confirm Date (lowest to highest)
 RFC Code: -- All --
 Begin Date (mm/dd/yyyy): 01 / 01 / 2007
 End Date (mm/dd/yyyy): 01 / 03 / 2007

If any of the above selections are changed, click "New Report" for screen refresh.

RFC Agency Link

ALC: 47000016
 Report: Agency Confirmation Report
 Run date: Mar 7 2007 11:06AM
 This report sorted by: confirm date (L to H), then by schedule (H to L)

SCHEDULE NUMBER	CHECK SYM	CONFIRMED DATE	CHECK/BOND RANGE	CERTIFIED NO CHECK NET	DOC TYPE
GS07Y1546	310	Jan 3 2007	01285288 01285307	55,257.58	E
GS07V2362	310	Jan 3 2007	01288971 01288972	5,907.01	E
GS07V2361	310	Jan 3 2007	01288858 01288875	6,275.80	E
GS07V2359	310	Jan 3 2007	01284353 01285287	2,626,784.45	W
GS07T2195	310	Jan 3 2007	01288969 01288970	1,741.75	E
GS07T2194	310	Jan 3 2007	01288797 01288857	23,217.27	E
GS07T2192	310	Jan 3 2007	01285308 01285310	1,886.92	E
GS07Q1196	3091	Jan 3 2007	11777236 11777236	1,150.00	A
GS07P1391	3091	Jan 3 2007	11777547 11777547	40.00	A
GS07C1858	3091	Jan 3 2007	11777183 11777235	259,851.56	A
310-7-001	310	Jan 3 2007	00000000 00000000	-850.24	O
RFC 310 TOTAL:		COUNT= 11		2,981,262.10	
ALC 47000016 TOTAL:		COUNT= 11		2,981,262.10	

DOCUMENT TYPES: A THRU E = SF1166 H = SF215- 133 I = SF215 1098, 2010
 N = SF5515-FMS3813 N AND O = TFS145 P= TFS3062
 Q= 146-FEDWIRE HELD AND RET PYMTS R = EFT COLL. T = SF215- 135
 V = TFS1185 W = SF166 OFFSET
 X = FOREIGN PAYMENT Y= 5206 CHECK ISSUE DISCREPANCY. Z = J. V.

[Back to Top](#)

[Accessibility](#) | [Contacts](#) | [Privacy Policy](#)

U.S. Department of the Treasury - Financial Management Service

Selection Criteria:

- ALC
- Report Type
- RFC Code
- Begin Date
- End Date

Displayed Report:

- Schedule Number
- Check Symbol
- Confirmed Date
- Check/Bond Range
- Certified No Check Amount
- Document Type



TDO Payment Support– Payment Inquiry

GOVERNMENTWIDE ACCOUNTING & REPORTING
gwa Modernization

HOME HELP LOG OFF

-- Go To -- Go

Welcome, asAgency View 04/16/2007 10:56:06 AM EDT

Support Listings ▾

Support Listings ▾ TDO Payments ▾

Home > Reports > Account Statement > TDO Payments Inquiry

TDO Payments Inquiry ?

* Required fields.

Agency

* ALC (Hold CONTROL to select multiple entries or SHIFT to select a range of entries)

* RFC Code

* Begin Date

* End Date

[Contact Us](#) | [Accessibility](#) | [Privacy Policy](#)

U. S. Department of the Treasury - Financial Management Service

Selection Criteria:

- Agency (Optional)
- ALC
- Report Type
- RFC Code
- Begin Date
- End Date

Agency Drop-Down Selection

DEPARTMENT OF THE TREASURY - (20)

All

DEPARTMENT OF AGRICULTURE - (12)

DEPARTMENT OF JUSTICE - (15)

DEPARTMENT OF THE TREASURY - (20)

RFC Code Drop-Down Selection

All

All

AUSTIN RFC - (220)

BIRMINGHAM RFC - (449)

CHICAGO RFC - (307)

KANSAS CITY RFC - (310)

Original CHICAGO RFC - (308)

PHILADELPHIA RFC - (303)

SAN FRANCISCO RFC - (312)



Displayed Payment Summary Report by ALC:

- RFC Code
- RFC Location
- Last Confirmed Date for payment information through RFC for selected date range
- Total amount confirmed through RFC for selected date range
- Total ALC payment amount for selected date range



GOVERNMENTWIDE
ACCOUNTING & REPORTING
gwa
Modernization

HOME HELP LOG OFF

-- Go To --

Welcome, Keith Jarboe 12/04/2006 03:09:35 PM EST

Account Statement ▾ ALC Statement ▾ Support Listings ▾

Support Listings ▾ TDO Payments ▾

Home > Reports > Account Statement > TDO Payments Inquiry > RFC Payments Summary

RFC Payments Summary

[Download ...](#) [Print in PDF](#)  [Modify Search](#)





Search Criteria

Agency: **Department of Agriculture** ALC: [view list](#)

Begin Date: **01/01/2007** RFC Code: **All**

End Date: **01/29/2007**

ALC: 1100011 ◀◀ Previous ALC Next ALC ▶▶ Page 1 2 3 4 5

View	RFC Code	Location	Last Confirmed Date	Total Amount
	220	Philadelphia	01/04/2007	20,000,000.00
	303	Austin	01/04/2007	100,000.00
	310	Kansas City	01/04/2007	100.00
	312	San Francisco	01/04/2007	-100.00
	349	Birmingham		0.00
Total				20,100,000.00

[Contact Us](#) | [Accessibility](#) | [Privacy Policy](#)

U. S. Department of the Treasury - Financial Management Service



TDO Payment Support– Payment Detail

Payment Detail Report – Schedule Highest to lowest within Confirmed Date lowest to highest

First Sort:
 -Schedule Number
 -Descending

- Schedule Number
- Schedule Number**
- Check Symbol
- Confirmed Date
- Check/Bond Range
- Document Type
- Net Amount

- Descending
- Ascending
- Descending**

Second Sort:
 -Confirmed Date
 -Ascending

- Confirmed Date
- None
- Schedule Number
- Check Symbol
- Confirmed Date**
- Check/Bond Range
- Document Type
- Net Amount

- Ascending
- Ascending**
- Descending
- None

GOVERNMENTWIDE ACCOUNTING & REPORTING
gwa Modernization

Welcome, Keith Jarboe 12/04/2006 03:09:35 PM EST

HOME HELP LOG OFF -- Go To -- Go

Account Statement ALC Statement Support Listings

Support Listings TDO Payments

Home > Reports > Account Statement > TDO Payments Inquiry > RFC Payments Summary > ALC Payment Details

ALC Payment Details

Print in PDF

Search Criteria
 Agency: Department of Agriculture ALC: 00000307
 Begin Date: 01/01/2007 RFC Code: 303
 End Date: 01/29/2007

Sort By Schedule Number Descending then Confirmed Date Ascending Sort

1-20 of 48 Records

Schedule Number	Check Symbol	Confirmed Date	Check/Bond Range		Document Type	Net Amount
			Begin Serial Number	End Serial Number		
2726-AT1-1	303	01/01/2007	000510068	00510070	E (SF1166)	32,400.00
2726-AT3-1	303	01/01/2007	000510068	00510070	E (SF1166)	66,000.00
2726-AT3-1	304	01/02/2007	000510068	00510070	I (SF215)	100.00
2726-AT3-1	304	01/02/2007	000510068	00510070	I (SF215)	100.00
2726-AT3-1	303	01/03/2007	000510068	00510070	I (SF215)	100.00
2726-AT3-1	303	01/03/2007	000510068	00510070	E (SF1166)	-100.00
2726-AT3-1	303	01/04/2007	000510068	00510070	I (SF215)	100.00
2726-AT3-1	303	01/04/2007	000510068	00510070	I (SF215)	100.00
2726-AT3-1	2211	01/04/2007	000510068	00510070	I (SF215)	100.00
2726-AT3-1	2233	01/04/2007	000510068	00510070	I (SF215)	100.00
2726-AT3-1	303	01/04/2007	000510068	00510070	Q (146-FEDWIRE HELD AND RET PYMTS)	2,186,985,994.90
2726-AT3-1	303	01/04/2007	000510068	00510070	I (SF215)	100.00
2757-AT3-1	2200	01/04/2007	000510068	00510070	I (SF215)	100.00
2757-AT3-1	2222	01/05/2007	000510068	00510070	I (SF215)	100.00
2757-AT3-1	303	01/05/2007	000510068	00510070	I (SF215)	100.00
2787-AT3-1	303	01/05/2007	000510068	00510070	I (SF215)	100.00
2787-AT3-1	303	01/05/2007	000510068	00510070	Y (5206 CHECK ISSUE DISCREPANCY)	248,390,265.54
2787-AT3-1	303	01/05/2007	000510068	00510070	I (SF215)	100.00
2787-AT3-1	303	01/08/2007	000510068	00510070	I (SF215)	100.00
71002MSPV1	303	01/08/2007	000510068	00510070	I (SF215)	100.00
Total						2,435,476,060.44

1-20 of 48 Records

Contact Us | Accessibility | Privacy Policy

U. S. Department of the Treasury - Financial Management Service

Displayed Report:
 -Schedule Number
 -Check Symbol
 -Confirmed Date
 -Check/Bond Range
 -Document Type
 -Net Amount



TDO Payment Support– Download Formats

- Flat-file and Comma-Separated Values (CSV) format– Remains the same as the existing RFC Agency Link
- Text File format – Replaced with PDF format

Flat-file Download Format

CSV Download Format

PDF Download Format

2018490422060428060427A04272006B0074	000000000000	00000000	0000000263016972
2018490422060427060428A04262006B0073	000000000000	00000000	0000000196700452
2018490422060427060428A04252006A0073	000000000000	00000000	0000000021361632
2018490422060426060425A04252006B0072	000000000000	00000000	0000000240277552
2018490422060425060424A04242006B0071	000000000000	00000000	0000000148963252
2018490422060424060423A04232006B0070	000000000000	00000000	0000000065358052
2018490422060424060422A04222006B0070	000000000000	00000000	0000000184393642
2018490422060421060420A04202006B0069	000000000000	00000000	0000000230701892
2018490422060420060419A04192006B0068	000000000000	00000000	00000001133651982
2018490422060420060419A04192006A0068	000000000000	00000000	0000000000097762
2018490422060419060418A04182006B0067	000000000000	00000000	0000000036568102
2018490422060418060417A04172006A0066	000000000000	00000000	000000006673482
2018490422060418060417A04172006B0065	000000000000	00000000	00000000499353272
2018490422060417060416A04162006B0064	000000000000	00000000	0000000203321962
2018490422060416060415A04152006A0064	000000000000	00000000	0000000131544812
2018490422060416060415A04152006B0063	000000000000	00000000	0000000365115172
2018490422060415060414A04142006B0062	000000000000	00000000	0000000200939572
2018490422060414060413A04132006B0061	000000000000	00000000	00000000007158902
2018490422060413060412A04122006B0060	000000000000	00000000	0000000000053302
2018490422060412060411A04112006B0059	000000000000	00000000	000000000008969152
2018490422060411060410A04102006B0058	000000000000	00000000	000000000049477342
2018490422060410060409A04092006B0057	000000000000	00000000	0000000106755482
2018490422060409060408A04082006B0056	000000000000	00000000	00000000367434582
2018490422060408060407A04072006B0055	000000000000	00000000	000000003989567022
2018490422060407060406A04062006B0054	000000000000	00000000	-000009297813091
2018490422060406060405A04052006B0053	000000000000	00000000	-00046775765330
2018490422060405060404A04042006B0052	000000000000	00000000	-000000275567700
2018490422060404060403A04032006B0051	000000000000	00000000	-0000000945903561
2018490422060403060402A04022006B0050	000000000000	00000000	-000000076454140
2018490422060402060401A04012006B0049	000000000000	00000000	-0000000531258231
2018490422060401060400A04002006B0048	000000000000	00000000	-0000000613406031
2018490422060400060400A04002006B0047	000000000000	00000000	-000000089429660
2018490422060400060400A04002006B0046	000000000000	00000000	-000000440715930
2018490422060400060400A04002006B0045	000000000000	00000000	-000000196483851
2018490422060400060400A04002006B0044	000000000000	00000000	-000007546092141
2018490422060400060400A04002006B0043	000000000000	00000000	-000096105365520
2018490422060400060400A04002006B0042	000000000000	00000000	-000000174001561
2018490422060400060400A04002006B0041	000000000000	00000000	-00000028633730
2018490422060400060400A04002006B0040	000000000000	00000000	-000000245280811
2018490422060400060400A04002006B0039	000000000000	00000000	-000000292071450
2018490422060400060400A04002006B0038	000000000000	00000000	-000000209763760
2018490422060400060400A04002006B0037	000000000000	00000000	-000000217941611
2018490422060400060400A04002006B0036	000000000000	00000000	-000000207628850
2018490422060400060400A04002006B0035	000000000000	00000000	-000000240640121
2018490422060400060400A04002006B0034	000000000000	00000000	-000000540851341
2018490422060400060400A04002006B0033	000000000000	00000000	-0000074449801430
2018490422060400060400A04002006B0032	000000000000	00000000	-000000206495710
2018490422060400060400A04002006B0031	000000000000	00000000	-000008518849461
2018490422060400060400A04002006B0030	000000000000	00000000	-000000177501331
2018490422060400060400A04002006B0029	000000000000	00000000	-000002389282070
2018490422060400060400A04002006B0028	000000000000	00000000	-000000282020660
2018490422060400060400A04002006B0027	000000000000	00000000	-000000674221301

	A	B	C	D	E	F	G
1	H	IAS00442					
2	L	Schedule	Check Symbol	Confirmed Date	Check Range	Certified Net	Doc.Type
3	D	'A04272006B0074	0	4/27/2006	00000000 00000000	263016.97 Z	
4	D	'A04262006B0073	0	4/26/2006	00000000 00000000	196700.45 Z	
5	D	'A04262006A0073	0	4/26/2006	00000000 00000000	1346.63 Z	
6	D	'A04252006B0072	0	4/25/2006	00000000 00000000	240277.55 Z	
7	D	'A04242006B0071	0	4/24/2006	00000000 00000000	140863.25 Z	
8	D	'A04242006A0071	0	4/24/2006	00000000 00000000	65580.52 Z	
9	D	'A04212006B0070	0	4/21/2006	00000000 00000000	184393.64 Z	
10	D	'A04202006B0069	0	4/20/2006	00000000 00000000	230701.89 Z	
11	D	'A04192006B0068	0	4/19/2006	00000000 00000000	1133631.98 Z	
12	D	'A04192006A0068	0	4/19/2006	00000000 00000000	97.76 Z	
13	D	'A04182006B0067	0	4/18/2006	00000000 00000000	36568.1 Z	
14	D	'A04172006A0066	0	4/17/2006	00000000 00000000	66733.48 Z	
15	D	'A04112006B0065	0	4/11/2006	00000000 00000000	409353.27 Z	
16	D	'A04102006B0064	0	4/10/2006	00000000 00000000	203321.96 Z	
17	D	'A04102006A0064	0	4/10/2006	00000000 00000000	130544.81 Z	
18	D	'A04072006B0063	0	4/7/2006	00000000 00000000	362153.17 Z	
19	D	'A04062006B0062	0	4/6/2006	00000000 00000000	200939.57 Z	
20	D	'A04052006B0061	0	4/5/2006	00000000 00000000	71588.9 Z	
21	D	'A04052006A0061	0	4/5/2006	00000000 00000000	2553.3 Z	
22	D	'A04042006B0060	0	4/4/2006	00000000 00000000	18969.15 Z	
23	D	'A04032006B0059	0	4/3/2006	00000000 00000000	14947.34 Z	
24	D	'A04032006A0059	0	4/3/2006	00000000 00000000	106733.41 Z	
25	D	'A03312006B0058	0	3/31/2006	00000000 00000000	367434.58 Z	
26	D	'A03302006B0057	0	3/30/2006	00000000 00000000	398567.02 Z	
27	D	220-6-082	220	4/28/2006	00000000 00000000	-92857813.09 I	
28	D	220-6-082	220	4/28/2006	00000000 00000000	-146775765.3 O	
29	D	220-6-081	220	4/27/2006	00000000 00000000	-275667.7 O	
30	D	220-6-081	220	4/27/2006	00000000 00000000	-429503.36 I	
31	D	220-6-080	220	4/26/2006	00000000 00000000	-76458.14 O	
32	D	220-6-080	220	4/26/2006	00000000 00000000	-531358.25 I	
33	D	220-6-079	220	4/25/2006	00000000 00000000	-613406.03 O	
34	D	220-6-079	220	4/25/2006	00000000 00000000	-858942.96 O	
35	H	???	???	???	???	-440715.93 O	

000000220 JAN/2007						
RFC MONTHLY REPORT						
RFC: AUSTIN						
DATE: Mar 7 2007						

ALC	SCHEDULE	CONFIRM	TX	AMOUNT	REC	

20180350	2007A00271	01/01/07	Z	31,226,808.16	1	

TOTAL ALC				31,226,808.16		

TOTAL DEPT				31,226,808.16		

TOTAL RFC				31,226,808.16		

DEBIT (4.10)				31,226,808.16		
CREDIT (4.10)						
COUNT				0		



GOVERNMENTWIDE
ACCOUNTING & REPORTING

gwa
Modernization



AUTHORITY TRANSACTION MODULE

ATM

GWAMP Day: Policy Impacts and System Changes

April 25, 2007

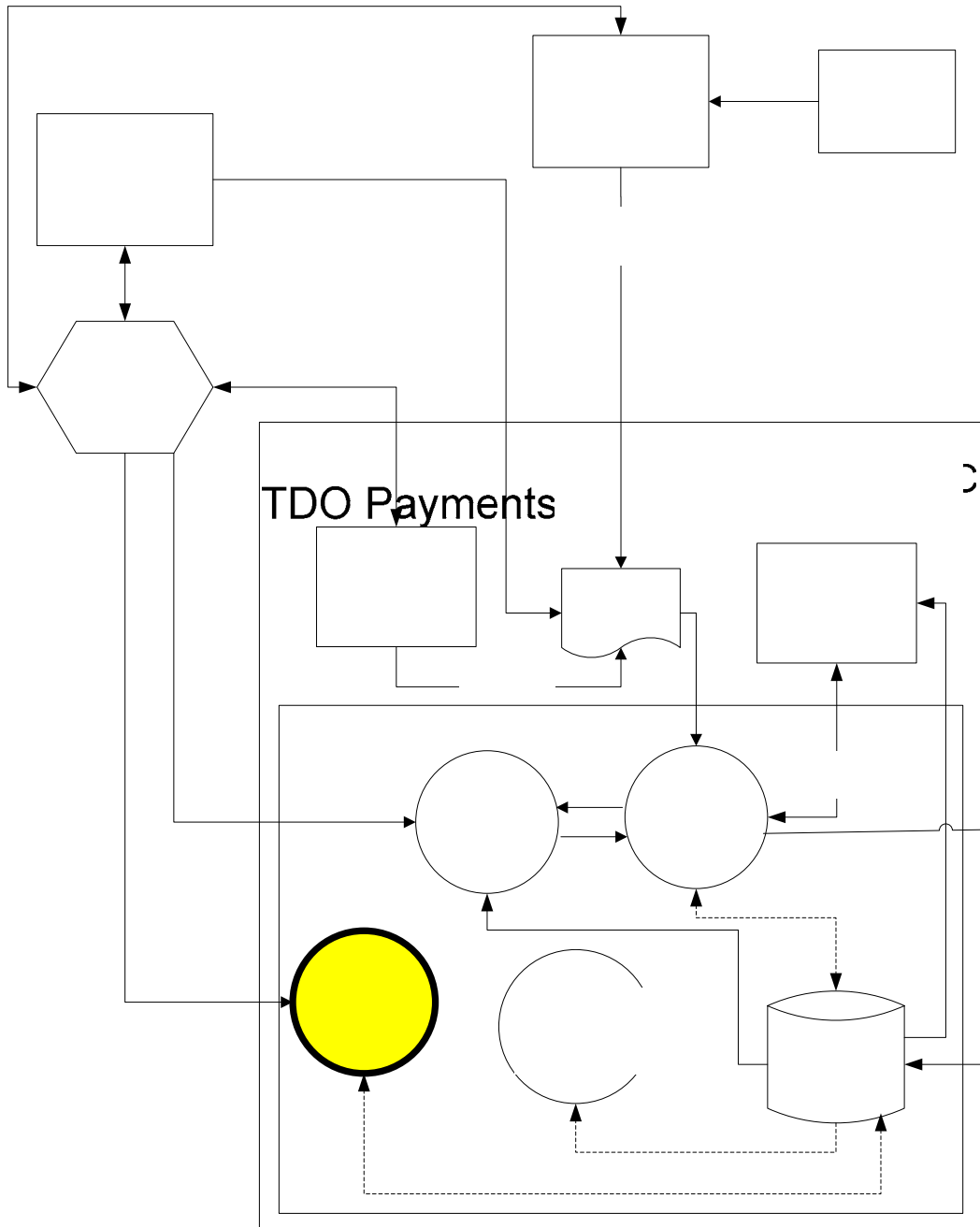

Collections

TAS/BETC or
C-Key



Governmentwide Accounting

Authority Transaction Module

- ATM 1.0
 - Provided a user with an automated process for creating, approving, and reviewing transactions.
 - Includes the following applications
 - Borrowing from Treasury
 - Non-Expenditure Transfer (NET)
 - Warrant Journal Voucher



Governmentwide Accounting

Authority Transaction Module

- ATM 2.0
 - Provide a user with an automated process for processing and display of Appropriation Warrant transactions.
 - Includes the following applications
 - Borrowing from Treasury
 - Non-Expenditure Transfer (NET)
 - Warrant Journal Voucher
 - **Appropriation Warrants**



GWA for the Web - Microsoft Internet Explorer provided by Financial Management Service

File Edit View Favorites Tools Help

Back Forward Stop Refresh Home Search Favorites Reload Mail Print Word Pad New Folder People

Address <https://www.gwa.gov/gwa/newTransactions> Go

Google G Go Bookmarks Popups okay Check Settings Links

GOVERNMENTWIDE ACCOUNTING & REPORTING
gwa
 Modernization

HOME HELP LOG OFF

-- Go To -- Go

Welcome, Carolann M. Marker 04/23/2007 09:29:38 AM EST

Home Transactions Reports

Authority Transaction Module

Home > Transactions > Authority Transaction Module

Transactions - Authority Transaction Module

New Transactions

- [Borrowing](#)
- [Non-Expenditure Transfer](#)
- [Journal Voucher Warrant](#)

[Pending Transactions](#)
[Posted Transactions](#)

[Contact Us](#) | [Accessibility](#) | [Privacy Policy](#)

U. S. Department of the Treasury - Financial Management Service

start Internet

GWA for the Web - M... Microsoft PowerPoint ... 12:26 PM

Governmentwide Accounting

Authority Transaction Module

- Projected release date 3rd Quarter 2007
- Must be enrolled as a GWA user
 - Same as enrollment for ATM 1.0
- If already enrolled
 - Go to manage applications
 - Add module



Governmentwide Accounting

Authority Transaction Module

Contacts Page for:
the following applications

- Borrowing from Treasury
- Non-Expenditure Transfer (NET)
- Warrant Journal Voucher
- **Appropriation Warrants**

Carolann.Marker@fms.treas.gov

(202) 874-9776

Valeria.Spinner@fms.treas.gov

(202) 874-6689

