



Provider

Organization Name	Id	Contact Name	Address	City	State	Work Phone	Fax	Email Address
Techno Solutions Group Inc	139	Victoria Ricciuti	540 Brickell Key Dr., Suite 528	Miami	FL	(305) 377-0036 x	(305) 675-0865	vricciuti@technosgi.com
Technology Associates International Corp.	183	Enrique Lastrilla	3375 Koopaka St., Ste C-320	Honolulu	HI	(808) 836-5900 x	(760) 603-1164	elastrilla@taic.net
Technology Integration Group	82	Peggy Ioeffler	1221 Kapiolani Blvd., Suite 410	Honolulu	HI	(858) 566-1900 x	(858) 566-8794	info@tig.com
Terabiz	40	Allison Sato	1001 Bishop St, Suite 1185, Pacific Tower	Honolulu	HI	(808) 540-5400 x	(808) 522-8828	allison@terabiz.com
Terra Genesis, Inc	184	Josephine Wynnan	4160 W. Kitty Hawk	Chandler	AZ	(480) 775-4000 x	(480) 785-1185	jwymnan@terragenesis.com
Thayer Consulting LLC	185	Michael Thayer	11718 Barrington Court, Ste 320	LA	CA	(310) 722-1745 x	(253) 369-4449	mthayer@thayerconsulting.com
The Axsean Group	41	Jon Jardine	7011 Koll Center Parkway, Suite 280	Pleasanton	CA	(925) 931-4475 x	(925) 931-4444	jon.jardine@axsean.com
The Database Center	192	Phi Nguyen	419A Atkinson Dr, Suite 1605	Honolulu	HI	(808) 945-2840 x	(808) 945-0279	phi@dbc-hawaii.com
The Lange Group	43	Nanci Lansley	1100 Ward Ave, Suite 1050	Honolulu	HI	(808) 545-1822 x	(808) 599-5264	
The Phoenix Group	84	Darren Jimenez	1956 Hackett Drive	Woodland	CA	(530) 668-1144 x	(530) 668-0900	darren@ppgweb.com
Third Day Solutions, LLC	186	Jeff May	6360 I-55 North, Ste 370	Jackson	MS	(601) 847-9301 x	(601) 957-9492	jeff.may@thirddaysolutions.com
Tour Software Inc	140	Peter Kaufman	58-133 Maunaloa St	Haleiwa	HI	(808) 638-5192 x	(808) 638-0526	pak@toursoft.com
Universal Systems Technology	85	Rohit Bardiyar	21711 West ten Mile Road, Suite 111	Southfield	MI	(248) 350-8786 x	(248) 350-2952	rohit.bardy@ust.net
Ursus Technologies Inc	86	Brian Henling	4250 Aurora Avenue North, Suite B-108	Seattle	WA	(206) 910-9563 x	(206) 548-1313	brian.henling@ursus-tech.com
USI-Hawaii, Inc	187	Harley Pennington	1001 Bishop St, Ste 822	Honolulu	HI	(808) 537-2214 x	(808) 537-2215	harley.pennington@ushawaii.com
Vernion Technology Solutions	207	Munish Gulati	825 E. Rand Road, Suite 210	Arlington Heights	IL	(847) 577-5256 x	(847) 577-5905	munish@vernon.com
Verizon Hawaii	141	Adam Park	1177 Bishop Street, A-16	Honolulu	HI	(808) 546-1515 x	(808) 546-8288	kevin.uyeda@verizon.com
VIP	44	Mason Moore	80 Iron Point Circle, Suite 100	Folsom	CA	(916) 985-9625 x	(916) 985-9632	mmoore@vipincorp.com
VitalChek Network Inc	87	H. Michael Barrett	4512 Central Pike	Hermitage	TN	(800) 669-8312 x	(615) 758-9243	mbarrett@vitalchek.com
Viva USA inc	88	James Devadoss	3601 Algonquin Road, Suite 425	Rolling Meadows	IL	(847) 368-0860 x	(847) 368-0864	james@viva-it.com
Voyager Systems Inc	143	Keith Haentei	360 Routh 101, Suite 1501	Bedford	NH	(603) 472-5172 x	(603) 472-8897	khaentei@voyagersystems.com
Wet Sand Enterprises LLC	145	Dan Dorszanski	2021 Pauoa Road	Honolulu	HI	(808) 524-9343 x	(808) 524-8064	dian@wet-sand.com

500632

CONTRACT NO 46621

BENJAMIN J. CAYETANO  
GOVERNOR



RAYMOND H. SATO  
COMPTROLLER

MARY PATRICIA WATERHOUSE  
DEPUTY COMPTROLLER

STATE OF HAWAII  
DEPARTMENT OF ACCOUNTING  
AND GENERAL SERVICES  
PO BOX 119  
HONOLULU, HAWAII 96810-0119

March 20, 2000

*Hand Del by Carl Waterhouse  
6-19-00*

Ms. Nani Lindsey  
The Lange Group  
1100 Ward Avenue, Suite 1050  
Honolulu, HI 96814

Dear Ms. Lindsey:

SUBJECT: Notice to Proceed  
ICS-FY-99-52  
Services to Develop and Implement a Replacement Land Court  
and Regular Automated Tracking System for the State of Hawaii

Enclosed is a fully executed copy of Agreement No. ICS-FY-99-52, Part 1 for your file.  
You are notified to proceed with the work upon receipt of this contract.

If you have any questions on this matter, please call Ms. Barbara Tom at  
(808) 586-1920.

Sincerely,

Lester M. Nakamura, Administrator  
Information and Communication Services  
Division

Enclosures

00 MAR 18 5 53 PM

500633

STATE OF HAWAII — DEPARTMENT OF TAXATION  
**TAX CLEARANCE APPLICATION**  
PLEASE TYPE OR PRINT CLEARLY

**1. APPLICANT INFORMATION:** (PLEASE PRINT CLEARLY)

Applicant UNIQUE COMPUTER SYSTEMS, INC.  
Address 1100 Ward Avenue, Suite 1050  
City/State/Zip Code Honolulu, Hawaii 96814  
DBA/Trade Name THE LANGE GROUP

**2. TAX IDENTIFICATION NUMBER(S):**

HAWAII GENERAL EXCISE ID # 1 0 1 9 3 8 0 6  
FEDERAL EMPLOYER ID # 9 9 - 0 2 0 6 1 2 3  
SOCIAL SECURITY # \_\_\_\_\_

**3. APPLICANT IS A/AN:** (CHECK ONLY ONE BOX)

- CORPORATION                       S CORPORATION                       TAX EXEMPT ORGANIZATION  
 INDIVIDUAL                               PARTNERSHIP                       ESTATE                       TRUST  
 LIMITED LIABILITY COMPANY               LIMITED LIABILITY PARTNERSHIP

**4. THE TAX CLEARANCE IS REQUIRED FOR:**

- CITY, COUNTY, OR STATE GOVERNMENT CONTRACT IN HAWAII \*               LIQUOR LICENSE \*  
 REAL ESTATE LICENSE                       CONTRACTOR LICENSE                       BULK SALES  
 FINANCIAL CLOSING                       PROGRESS PAYMENT                       PERSONAL  
 HAWAII STATE RESIDENCY                       FEDERAL CONTRACT                       LOAN  
 SUBCONTRACT                       OTHER \_\_\_\_\_

\* IRS APPROVAL STAMP IS FOR PURPOSES INDICATED BY ASTERISK

**5. NO. OF CERTIFIED COPIES REQUESTED:**

5

**6. SIGNATURE:**

Yolanda H. Lindsey                      President  
PRINT NAME                      PRINT SPECIFIC TITLE: Corporate Officer, General Partner, Individual (Sole Proprietor)  
[Signature]                      1-26-00                      (808) 545 - 1822                      (808) 599 - 5264  
SIGNATURE                      DATE                      TELEPHONE                      FAX

POWER OF ATTORNEY. If submitted by someone other than a Corporate Officer, General Partner, or Individual (Sole Proprietor), a power of attorney (State of Hawaii Department of Taxation Form N848) must be submitted with this application. If a Tax Clearance is required from the Internal Revenue Service, IRS Form 8821, or IRS Form 2848 is also required. Applications submitted without proper authorization will be sent to the address of record with the taxing authority. UNSIGNED APPLICATIONS WILL NOT BE PROCESSED.

PLEASE TYPE OR PRINT CLEARLY — THE FRONT PAGE OF THIS APPLICATION BECOMES THE CERTIFICATE UPON APPROVAL.

SEE PAGE 2 ON REVERSE & INSTRUCTIONS. Failure to provide required information on page 2 of this application or as required in the separate instructions to this application will result in a denial of the Tax Clearance request.

FOR OFFICE USE ONLY  
BUSINESS START DATE IN HAWAII  
IF APPLICABLE  
02/17/1981  
HAWAII RETURNS FILED  
IF APPLICABLE  
19\_\_\_\_ 19\_\_\_\_ 19\_\_\_\_  
STATE APPROVAL STAMP  
State of Hawaii  
APPROVED  
[Signature]  
JAN 26 2000  
per [Signature]  
Department of Taxation  
INTERNAL REVENUE SERVICE  
APPROVED  
19-00379  
JAN 26 2000  
per [Signature]  
Pacific-Northwest District  
CERTIFIED COPY STAMP

500634

# The Lange Group

Software Systems Analysis & Telecommunications Consulting

---

## CERTIFICATION

I, Yolanda H. Lindsey, Secretary of Unique Computer Systems, Inc., a Hawaii corporation, do hereby certify that the following is a full, true and correct copy of a resolution duly adopted by the Board of Directors of said Corporation, at its meeting held on the twenty first day of January, 2000 at it's offices at 1100 Ward Avenue, Suite 1050, Honolulu, Hawaii 96814, at which a quorum was present, and that said resolution has not been modified, amended or rescinded and continues in full force and effect:

"RESOLVED that any individual at the time of holding the position of President is hereby authorized to execute on behalf of the Corporation, any bid, proposal, or contract for software and consulting services to be performed by the Corporation.

IN WITNESS WHEREOF, I have hereunto set my hand and affixed the corporate seal of Unique Computer Systems, Inc. dba The Lange Group, on this twenty six day of January, 2000.

  
Secretary

SEAL

500635

**STATE OF HAWAII  
AGREEMENT FOR GOODS OR SERVICES  
BASED UPON COMPETITIVE SEALED PROPOSALS**

This Agreement, executed on the respective dates of the signatures of the parties shown hereafter, is effective as of January 18, /19 2000, between the \_\_\_\_\_

Department of Accounting and General Services

(Insert name of state department, agency, board, or commission)

State of Hawaii (hereinafter "STATE"), by its Comptroller

(hereinafter "DIRECTOR"), and Unique Computer Systems, Inc.  
dba THE LANGE GROUP

(hereinafter "CONTRACTOR"), a Corporation

(Insert "corporation," "partnership," "joint venture," "sole proprietorship," or other legal form of the Contractor)

under the laws of the State of Hawaii, whose business address and

taxpayer identification number are as follows: 1100 Ward Avenue, Suite 1050  
Honolulu, Hawaii 96814

Taxpayer ID: 1019306 Federal: 99-0206123

**RECITALS**

A. The STATE is in need of the goods or services, or both, described in this Agreement and its attachments.

B. The STATE has issued a request for competitive sealed proposals, and has received and reviewed proposals submitted in response to the request.

C. The solicitation for proposals and the selection of the CONTRACTOR were made in accordance with section 103D-303, Hawaii Revised Statutes ("HRS"), Hawaii Administrative Rules, Title 3, Department of Accounting and General Services, Subtitle 11 (hereinafter "Procurement Rules"), sections 3-122-41 through 3-122-60, and applicable procedures established by the appropriate Chief Procurement Officer ("CPO").

D. The CONTRACTOR has been identified as the responsible and responsive offeror whose proposal is the most advantageous for the STATE, taking into consideration price and the evaluation factors set forth in the request.

E. The STATE desires to retain and engage the CONTRACTOR to provide the goods or services, or both, as the case may be, and the CONTRACTOR is agreeable to providing said goods or services, or both.

F. Money is available to fund this Agreement pursuant to:

(1) Act 91, SLH 1999

or (2) \_\_\_\_\_

(Identify state account)

(Identify federal account)

00 MAR 18 65 70

500636

BE OPENED

both, in the following amounts:

State \$1,297,668.45

Federal \$

G. Pursuant to 26-6 HRS, the STATE is authorized to enter into this Agreement.

NOW, THEREFORE, in consideration of the promises contained in this Agreement, the STATE and the CONTRACTOR agree as follows.

1. Scope of Performances. The CONTRACTOR shall, in a proper and satisfactory manner as determined by the STATE, provide all the goods or services, or both, set forth in the request for competitive sealed proposals number ICS FY 99-52 ("Request"), and the CONTRACTOR's accepted proposal ("Proposal"), both of which, even if not physically attached to this Agreement, are hereby made a part this Agreement.

2. Compensation. The CONTRACTOR shall be compensated for goods supplied or services performed, or both, under this Agreement in a total amount not to exceed One Million Two Hundred Ninety Seven Thousand Six Hundred Sixty eight and 45/100 DOLLARS (\$1,297,668.45), including taxes, at the time and in the manner set forth in the Request and CONTRACTOR's proposal.

3. Bonds. The CONTRACTOR (is) (~~is not~~) required to provide a (performance) (payment) (performance and payment) bond in the amount of No DOLLARS (\$ 0.00).

4. Standards of Conduct Declaration. The Standards of Conduct Declaration of the CONTRACTOR, is attached and is made a part of this Agreement.

5. Other Terms and Conditions. The General Conditions and any Special Conditions are attached hereto and made a part of this Agreement. In the event of a conflict between the General Conditions and the Special Conditions, the Special Conditions shall control. In the event of a conflict among the documents, the order of precedence shall be as follows: (1) Agreement, including all attachments and addenda; (2) Request, including all attachments and addenda; and (3) Proposal.

6. Liquidated Damages. Liquidated damages shall be assessed in the amount of One Hundred DOLLARS (\$100.00) per day, in accordance with the terms of paragraph 9 of the General Conditions.

7. Notices. Any written notice required to be given by any party to this Agreement shall be (a) delivered personally, or (b) sent by United States first class mail, postage prepaid. Notice required to be given to the Director shall be sent to the Director's office in

Honolulu, Hawaii. Notice to the agency procurement officer shall be sent to: \_\_\_\_\_

Notice to the CONTRACTOR at the CONTRACTOR's address as indicated in this Agreement. A notice shall be deemed to have been received three (3) days after mailing or at the time of actual receipt, whichever is earlier. The CONTRACTOR is responsible for notifying the STATE in writing of any change of address.

IN VIEW OF THE ABOVE, the parties execute this Agreement by their signatures, on the dates below, to be effective as of the date first above written.

STATE

By *Raymond H. Sato*

Print Name Raymond H. Sato

Title State Comptroller

Date 3/17/00

FUNDING AGENCY (to be signed by head of funding agency if other than the Comptroller)

By *Timothy E. Johns*

Print Name Timothy E. Johns

Title Chairperson, Board of Land and Natural Resources, Director of Land and Natural Resources

Date March 23, 2000

CONTRACTOR

By *Yolanda H. Lindsey*

Print Name Yolanda H. Lindsey

Title President LS

Date January 26, 2000

APPROVED AS TO FORM:

*Dean Jackson*  
Deputy Attorney General

\*Evidence of authority of the CONTRACTOR's representative to sign this Agreement for the CONTRACTOR must be attached.



**CERTIFICATION OF EXEMPTION FROM CIVIL SERVICE**

**1. By Heads of State Departments or Agencies Pursuant to Delegation of the Director of Human Resources Development<sup>1</sup>**

Pursuant to the delegation of the authority by the Director of Human Resources Development, I certify that the services provided under this Agreement, and the person(s) providing the services under this Agreement are exempt from the civil service, pursuant to Hawaii Revised Statutes §76-16.

Raymond H. Sato  
(signature)

3/17/00  
(date)

Raymond H. Sato

Print Name

State Comptroller

Print Title

**2. By the Director of Human Resources Development, State of Hawaii<sup>2</sup>**

I certify that the services provided under this Agreement, and the person(s) providing the services under this Agreement are exempt from the civil service, pursuant to Hawaii Revised Statutes §76-16( ).

\_\_\_\_\_  
(signature)

\_\_\_\_\_  
(date)

\_\_\_\_\_  
Print Name

\_\_\_\_\_  
Print Title, if designee of Director  
of Human Resources Development

<sup>1</sup>This part of the form may be used by all department heads and others to whom the Director of Human Resources Development has delegated authority to certify Hawaii Revised Statutes section 76-16 civil service exceptions. The specific paragraph(s) of section 76-16 upon which an exemption is based should be noted in the contract file. NOTE: Authority to certify exceptions under Hawaii Revised Statutes sections 76-16(2) and 76-16(3) has not been delegated; only the Director of Human Resources Development may certify sections 76-16(2) and 76-16(3) exceptions.

<sup>2</sup>This part of the form may be used only by the Director of Human Resources Development or the Director's designee. See NOTE at footnote 1.

500639

CONTRACTOR'S ACKNOWLEDGMENT

State of Hawaii)

SS.

City of Honolulu)  
County of Honolulu)

On this 26th day of January <sup>6<sup>th</sup> 2000</sup> ~~199~~, before me personally

appeared Yolanda H. Lindsey, to me personally

known, who being by me duly sworn, did say that he/she is the \_\_\_\_\_

President \_\_\_\_\_ of

Unique Computer Systems, Inc. dba The Lange Group the

CONTRACTOR named in the foregoing instrument, and that he/she is authorized to sign

said instrument on behalf of the CONTRACTOR, and acknowledges that he/she executed

said instrument as the free act and deed of the CONTRACTOR.

150

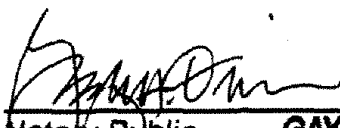

Notary Public, GAYLE VILLADOS

My commission expires: 06-14-2000

500640

STATE OF HAWAII  
CERTIFICATE OF CURRENT COST OR PRICING DATA

This is to certify that, to the best of my knowledge and belief, cost or pricing data as defined in section 3-122-122 and submitted pursuant to section 3-122-125; either actually or by specific identification in writing to the procurement officer in support of ICS-FY-99-52 \* are accurate, complete, and current as of November 15, 1999 \*\*\*  
(month, date, year)

This certification includes the cost or pricing data supporting any advance agreement(s) between the offeror and the (State) which are part of the proposal. Please type or print:

Firm: Unique Computer Systems, Inc. dba THE LANGE GROUP	Date of Execution: *** December 22, 1999
Name: Yolanda H. Lindsey	Title President

  
(Signature)

1-26-2000  
(Date)

(End of Certificate)

\* Describe the proposal, quotation, request for price adjustment or other submission involved, giving appropriate identifying number (e.g. RFP Number).

\*\* The effective date shall be a mutually determined date prior to but as close to the date when price negotiations were concluded and the contract price was agreed to as possible. The responsibility of the offeror or contractor is not limited by the personal knowledge of the offeror's or contractor's negotiator if the offeror or contractor had information reasonably available at the time of the agreement, showing that the negotiated price is not based on accurate, complete, and current data.

\*\*\* This date should be as soon after the date when the price negotiations were concluded and the contract price was agreed to as practical.

500641

## STANDARDS OF CONDUCT DECLARATION

For the purposes of this declaration:

"Agency" means and includes the State, the legislature and its committees, all executive departments, boards, commissions, committees, bureaus, offices, the University of Hawaii, and all independent commissions and other establishments of the state government but excluding the courts.

"Controlling interest" means an interest in a business or other undertaking which is sufficient in fact to control, whether the interest is greater or less than fifty per cent (50%).

"Employee" means any nominated, appointed, or elected officer or employee of the State, including members of boards, commissions, and committees, and employees under contract to the State or of the constitutional convention, but excluding legislators, delegates to the constitutional convention, justices, and judges.

On behalf of Unique Computer Systems, Inc.  
dba The Lange Group, CONTRACTOR, the undersigned does declare as follows:

1. CONTRACTOR /is/ (is not) a legislator or an employee or a business in which a legislator or an employee has a controlling interest.\*
2. CONTRACTOR has not been assisted or represented by a legislator or employee for a fee or other compensation to obtain this Agreement and will not be assisted or represented by a legislator or employee for a fee or other compensation in the performance of the Agreement, if the legislator or employee had been involved in the development or award of the Agreement.
3. CONTRACTOR has not been assisted or represented for a fee or other compensation in the award of this Agreement by an Agency employee or, in the case of the Legislature, by a legislator.
4. CONTRACTOR has not been represented or assisted personally on matters related to the Agreement by a person who has been an employee of the Agency within the preceding two (2) years and who participated while in state office or employment on the matter with which the Agreement is directly concerned.
5. CONTRACTOR has not been represented or assisted on matters related to this Agreement, for a fee or other consideration by an individual who, within the past twelve (12) months, has been an Agency employee, or in the case of the Legislature, a legislator.
6. CONTRACTOR has not been represented or assisted in the award of this Agreement for a fee or other consideration by an individual who, a) within the past twelve (12) months, served as an Agency employee or in the case of the Legislature, a legislator, and b) participated while an employee or legislator on matters related to this Agreement

500642

CONTRACTOR understands that the Agreement to which this document is attached is voidable on behalf of the STATE if this Agreement was entered into in violation of any provision of chapter 84, HRS, commonly referred to as the Code of Ethics, including the provisions which are the source of the declarations above. Additionally, any fee, compensation, gift, or profit received by any person as a result of a violation of the Code of Ethics may be recovered by the STATE.

DATED: Honolulu, Hawaii, January 26, 192000.

CONTRACTOR

By

Title

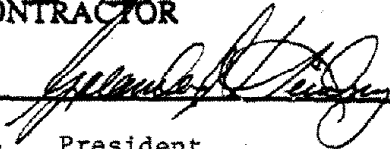
  
\_\_\_\_\_  
President  
\_\_\_\_\_

\*Reminder to Agency: If "is" is circled, the Agency is required, under section 84-15, HRS, to file with the State Ethics Commission, ten (10) days before the Agreement is entered into, a written justification as to why the Agreement was not required to be competitively bid.

500643

## SCOPE OF SERVICES

## CONTRACT FOR RFP NO. ICS-FY-99-052 – PART 1

SERVICES TO DEVELOP AND IMPLEMENT A REPLACEMENT  
LAND COURT AND REGULAR AUTOMATED TRACKING SYSTEM  
FOR THE STATE OF HAWAII

The Scope of Services to be provided by this contract is as defined in RFP No. ICS-FY-99-52 and the proposal of the Contractor submitted and awarded for completion of work for Part 1.

Part 1 = Lange Group and is for Phases 1 through 5, as follows:

1.	Establish BOC Network	240,782.21
2.	BCIS Reqmts Validation	48,458.02
3.	Replace REG and LC System	408,104.01
4.	Imaging Capability – BOC	519,230.95
5.	Imaging Capability – BCIS	<u>81,093.26</u>

Total Initial Contract amount	1,297,668.45
-------------------------------	--------------

Part 1 Total Bid = 1,701,985.54; Post Imp Support =	267,752.80
---	------------

Remaining for Supplemental Agreements =	404,317.09
	267,752.80 (support)
	<u>97,461.46 (optional)</u>

Total: Lange Group for Part 1 solution	2,067,199.80
--	--------------

500644

TIME OF PERFORMANCE

CONTRACT FOR RFP NO. ICS-FY-99-052 – PART 1

SERVICES TO DEVELOP AND IMPLEMENT A REPLACEMENT  
LAND COURT AND REGULAR AUTOMATED TRACKING SYSTEM  
FOR THE STATE OF HAWAII

The Time of Performance of Services is as defined in the RFP and amended by the Best and Final Offer Request letter included by reference by this contract to Lange Group. The Best and Final submission letter includes implied amendments to the Section 2.3 Significant Dates in the RFP (attached for reference).

Time of Performance is as proposed by Part 1 vendor – Lange Group

The initial contract is expected to terminate June 30, 2000.

500645

**2.3 SIGNIFICANT DATES**

The delivery and work schedule set out herein represents the State's best estimate of the schedule that will be followed. If a component of this schedule, such as Proposals Due date is delayed, the rest of the schedule may be shifted by the same number of days. The approximate schedule is as follows: All time is shown as Hawaiian Standard Time (HST)

Advertisement of RFP and Proposal Pick-up	April 5, 1999
Optional Site Visit	April 6 to May 18, 1999
Deadline for Written Inquiries; 10:00 a.m.	April 19, 1999
Deadline for Request to Utilize Another Methodology	April 19, 1999
Deadline for Letter of Intent; 10:00 a.m.	April 21, 1999
Response to Offerors' Written Inquiries	May 5, 1999
Deadline for a Additional Written Inquiries	May 7, 1999
Response to Offerors' Additional Written Inquiries	May 12, 1999
Deadline for a Next Additional Written Inquiries	May 14, 1999
Response to Offerors' Additional Written Inquiries	May 19, 1999
Proposal Due; 10:00 a.m.	May 28, 1999
Compliance Review for Proposals	June 1, to June 9, 1999
Notices of Compliance Qualification or Disqualification Mailed	June 10, 1999
Selection of Priority Listed Offerors	August 6, 1999
Discussions (if any) with Priority Listed Offerors	August 16, 1999 to October 8, 1999
Best and Final Offer Due; 10:00 a.m.	November 15, 1999
Contractor Selection	November 26, 1999
Notice of Award	December 1, 1999
Notice to Proceed/Estimated Date of Contract Issuance	December 13, 1999
Estimated Start Date	December 15, 1999
Work Plan Presentation for PART 1	December 27, 1999
Work Plan Presentation for PART 2	December 27, 1999
Final Work Plan Submission for PART 1	January 10, 2000
Final Work Plan Submission for PART 2	January 10, 2000



**PROPOSAL PREPARATION**

---

Estimated Initial Contract Period for Part1

December 15, 1999

to June 30, 2000

Estimated Completion Date: Part 1 and 2 all Phases

June 30, 2001

Estimated Completion; Post Implementation Support

June 30, 2004

COMPENSTION AND PAYMENT SCHEDULE

CONTRACT FOR RFP NO. ICS-FY-99-052 – PART 1

SERVICES TO DEVELOP AND IMPLEMENT A REPLACEMENT  
LAND COURT AND REGULAR AUTOMATED TRACKING SYSTEM  
FOR THE STATE OF HAWAII

The Compensation and Payment Schedule for this contract is as defined in RFP No. ICS-FY-99-52 and the proposal of the Contractor submitted and awarded for completion of work for Part 1 to Lange Group.

The Best and Final Offer Request letter amends Special Provisions in the RFP and is included in this contract by reference.

500648

**SPECIAL CONDITIONS**

**CONTRACT FOR RFP NO. ICS-FY-99-052 – PART 1**

**SERVICES TO DEVELOP AND IMPLEMENT A REPLACEMENT  
LAND COURT AND REGULAR AUTOMATED TRACKING SYSTEM  
FOR THE STATE OF HAWAII**

The Special Conditions for this contract is titled Appendix B Special Provisions in the RFP and are attached for information as overrides to General Conditions (also attached).

The Best and Final Offer Request letter to Lange Group for Part 1 amends Special Provisions in the RFP and is included in this contract by reference and is attached.

**500649**



**STATE OF HAWAII**  
**DEPARTMENT OF ACCOUNTING**  
**AND GENERAL SERVICES**

PO BOX 119  
HONOLULU HAWAII 96810-0119

November 1, 1999

Ms. Nani Lindsey  
THE LANGE GROUP  
1100 Ward Avenue, Suite 1050  
Honolulu, Hawaii 96814

Facsimile: (808) 599-5264

Dear Ms. Lindsey:

Re: RFP ICS-FY-99-052, PART 1

Please submit a Best and Final Offer to the Information and Communication Services Division, attention Barbara Tom by 10:00 a. m. on November 15, 1999, based on the following additional required information of the original RFP. In your best and final, indicate your agreement or elaborate on how you plan to achieve the results desired.

1. ICSD recently installed the RS/6000 SP2 system. Leverage this recent acquisition to meet the requirements of Section 3.8 of RFP No. ICS-FY-99-052.
2. Price schedule is to be based on an amendment to Section 3.10. IMPLEMENTATION PLAN, paragraph 1, to state:

*"The minimum expected to be completed in the initial contract period for Part 1 consists of phases determined as Phase 1 (tasks 1-3). Phase 2 (tasks 4-5). Phase 3 (tasks 6-7), Phase 4 (tasks 8-9), Phase 5 (task 10), and Phase 6 (task 11) will be contracted based upon available funding. Part 2 (task 12) will also be awarded and contracted based on availability of funding. Any remaining work shall then be contracted as supplemental agreements for phases based on available funding."*

Please provide your pricing based on the above changes.

3. The RFP is further amended to replace Appendix B, Page B-1 (Final May 3, 1999), to correct the TERM OF CONTRACT, sentence one to state:

*"Term of contract shall be initially, and subsequently, for a period agreed upon by the contractor and the Bureau of Conveyances (BOC) to complete the work required for all phases contracted."*

500650

Appendix B, Page B-1 (Final May 3, 1999). METHOD OF AWARD, is also amended by adding:

"Award to be based on substantive evaluation by the Project Review Committee. Execution of Contract and Notice to Proceed will be in the manner provided for in the implementation phases. However, Notice to Proceed may be accelerated but not necessarily in the sequence described in Section 3.10 as amended."

Will this pose a problem for you?

4. Immediate and timely remediation of the new system is critical to our public servicing requirements. Programming and technical assistance located in Honolulu supports this need. Please provide a detailed schedule of post implementation charges to ensure reliable on-site response and long term support. Charges should also reflect hardware and software support that includes but is not limited to license fees, maintenance and support fees, and any recurring charges anticipated.
5. Parallel testing of the new system will be conducted with no interruptions to operations. How will this be accomplished and will parallel testing involve the entire BOC staff?
6. The RFP calls for the migration of the current LCATS (Land Court Automated Title System) information to the BCIS. Based on the above, please elaborate on how your solution accommodates and supports this requirement.
7. Remote sites on the neighbor islands are to be fully functional. Please elaborate on your proposal, specifically equipment, communication options, hardware and software configuration requirements. Also identify potential restrictions that may be encountered. Site selections limited to Oahu (Honolulu), Kauai (Lihue), Maui (Wailuku), and Hawaii (Hilo and Kona).
8. Internet access poses security problems. Please identify the security levels included in your proposal and the problems they address. Is there a security "master" to identify different security options?

Should you have any questions, contact Barbara Tom, Planning and Project Management Officer, at (808) 586-1920.

Sincerely,



Lester M. Nakamura, Administrator  
Information and communication  
Services Division

500651

## APPENDIX B

---

### SPECIAL PROVISIONS

The Special Provisions is included in this appendix as a separate document.

#### SCOPE OF WORK

This RFP solicits offers to provide services to develop and implement a replacement Land Court and Regular Automated Tracking system for the Bureau of Conveyances (BOC's) multiple existing systems. The new system will meet all process, function, data, security, and other technical requirements of the BOC, and offerors shall propose a packaged solution for effective automation of the BOC as well as services required to modify, test, convert, and implement a replacement system for the BOC.

*It is the responsibility of the Contractor to deliver all the products and services detailed in this RFP in accordance with the State standard methodology for the tasks and activities, as well as deliverable phase end documents for the Packaged System Life Cycle, including External and Internal Specifications and Programming for all customization of packaged software that may be necessary and to complete the Test, Conversion, and Implementation phases and documents (or a pre-approved contractor methodology and its tasks/activities and documentation).*

All proposed work shall be in accordance with these Special Provisions, specifications, and the General Terms and Conditions, included by reference and made a part hereof. Copies of the General Terms and Conditions are contained in Appendix C of this RFP.

#### TERM OF CONTRACT

Term of contract shall be initially for a nine months period, beginning approximately August 2, 1999 and ending March 31, 2000. Subsequent Supplemental Agreements may be executed for Phase 2, and post implementation support, with final completion of all work and termination of the contract and all Supplemental Agreements, including post implementation support, by December 31, 2004. The project/contract, or any of its supplemental agreements, may be extended by mutual agreement for additional mutually agreed periods of one (1) year, up to three such extensions.

#### BID PREPARATION

Offeror must submit its offer using offeror's exact legal name as registered with the Department of Commerce and Consumer Affairs, if applicable. Failure to do so may delay proper execution of the contract.

Offeror's authorized signature shall be an original signature in ink. If the offer is unsigned or the affixed signature is a facsimile or a photocopy, the offer shall be automatically rejected unless accompanied by other material, containing an original signature indicating the offeror's intent to be bound.

#### METHOD OF AWARD

Prior to Awarding Contract, the State will require verification of the following insurance coverages:

Workers Compensation  
Temporary Disability  
Unemployment Insurance

500652

## APPENDIX B

Prepaid Health Insurance  
Liability Insurance (See Provision below)

### PAYMENT

Section 103-10, Hawaii Revised Statutes, provides that the State shall have thirty (30) calendar days after receipt of invoice or satisfactory completion of contract to make payment. For this reason, the State will reject any bid submitted with a condition requiring payment within a shorter period. Further, the State will reject any bid submitted with a condition requiring interest payments greater than that allowed by Section 103-10, H.R.S., as amended.

The State will not recognize any requirement established by the Contractor and communicated to the State after award of the contract, which requires payment within a shorter period or interest payment not in conformance with statute.

For the fiscal year period August 2, 1999 to March 31, 2000, the State agrees to pay the Contractor for satisfactory completion of work for Phase 1, which minimally is expected to include Tasks 1-6. The initial contract amount is dependent upon the proposal/solution selected by the BOC and awarded.

The remainder of the work, i.e. Phase 2, Tasks 7-11, shall not be performed by the Contractor and the State will not be required to pay for such work unless and until funds are available. Therefore, if and when funds become available, the State and the Contractor will execute supplemental agreement(s) to this contract covering the remainder of the work for a which Contractor shall be paid at the rate accepted by the State, contingent upon availability of funds. Therefore, in the event that funds for Phase 2 are not appropriated and allotted in future fiscal years, this agreement will terminate with no further liability or obligation by the Contractor or by the State.

Part 2, Task 12 may be proposed and awarded separately.

### ADDITIONS AND EXCEPTIONS TO THE GENERAL TERMS & CONDITIONS

Cancellation of Solicitations and Rejection of Offers. The solicitation may be cancelled or the offers may be rejected, in whole or in part, when in the best interest of the purchasing agency, as provided in sections 3-122-95 through 3-122-97, Hawaii Administrative Rules.

General Terms & Conditions Not Applicable. This solicitation is a Request for Proposals. Sections 2.11 and 2.14 of the General Terms & Conditions, which apply specifically to the Request for Proposals method of source selection, are not applicable to Invitations for Bids. Also sections 2.10 and 2.13, which apply specifically to the Invitation for Bids method of source selection, are not applicable to Requests for Proposals.

Records Retention. The Contractor and any subcontractors shall maintain the books and records that relate to the Agreement and any cost or pricing data for three (3) years from the date of final payment under the Agreement.

### PERMITS, CERTIFICATES, AND LICENSES

The Contractor shall obtain and pay for all permits, certificates, and licenses required and necessary for the performance of work specified herein, shall post all notices required by law, and shall comply with all laws, ordinances, and regulations bearing on the conduct of the work as

## APPENDIX B

---

specified.

### WORK PROGRESS

In the event the Contractor anticipates or encounters any difficulties with regard to targeted completion dates or any requirement of the contract, the Contractor shall, in writing, immediately notify the ICSD Procurement Officer, providing all pertinent details which will be for informational purposes only. Receipt of such notification by the ICSD Procurement Officer shall not constitute any expressed or implied agreement of modification to the contract.

### CUTTING AND FITTING

No cutting, notching, drilling, or altering of any kind shall be done to the building by the Contractor without first obtaining permission from the DLNR. Further, this work may require compliance to Chapter 104, Hawaii Revised Statutes, titled Wages and Hours of Employees on Public Works (see provision for Rate of Wages & Wage Certificate below).

### BUILDING REPAIRS

The Contractor shall be liable and responsible for any building repairs required by reason of Contractor's work and caused by Contractor's employees. Any required repairs of any kind shall be made at the cost of the Contractor. The Contractor shall take the necessary precautions to protect the building areas adjacent to Contractor's work.

### ACCESS AND AUTHORITY

The work shall be available for inspection, at any time, by the department or its representatives. All materials and work not in conformity with the specifications shall be subject to rejection. All rejected work or materials shall be immediately replaced with those called for in the specifications.

The department's representatives shall have the right to order the work of the Contractor or any subcontractor wholly or partially stopped if, in their judgment, the materials furnished or the work being done is not in strict accordance with the Specifications herein, or until any objectionable person or material is removed from the premises, and shall have the right to declare the contract forfeited for nonperformance when not being executed according to the intent and meaning of the contract. Such stoppage, suspension, or forfeiture shall not in any way invalidate any terms of the contract, and no extra compensation shall be allowed the Contractor by reason of such stoppage or suspension. The State shall notify the Contractor in writing of any deviations in the performance of the Contractor's obligations herein, and the Contractor shall be given a twenty-four (24) hour period to cure such deviations to the satisfaction of the State before executing the Contractor's rights hereunder.

### CLEAR AWAY

Throughout the progress of work under this contract, the Contractor shall keep the working area free from debris of all types and remove from the premises all rubbish resulting from any work done by the Contractor and leave the work areas in a "broom clean" condition on a daily basis. At the completion of its work, the Contractor shall leave the premises in a clean and finished condition.

### LIABILITY INSURANCE



## APPENDIX B

Contractor shall maintain insurance acceptable to the State in full force and effect throughout the term of this contract. The policy or policies of insurance maintained by the Contractor shall provide the following limit(s) and coverage(s):

<u>Coverage</u>	<u>Limits</u>
Commercial General Liability (occurrence form)	\$300,000 combined single limit per occurrence for bodily injury and property damage

Each liability insurance policy required by this contract shall contain the following clauses:

1. "This insurance shall not be canceled, limited in scope of coverage or non-renewed until after 30 days written notice has been given to the State of Hawaii, Department of Accounting and General Services, State Procurement Office, P.O. Box 119, Honolulu, Hawaii 96810-0119."
2. "The State of Hawaii is added as an additional insured as respects to operations performed for the State of Hawaii."
3. "It is agreed that any insurance maintained by the State of Hawaii will apply in excess of, and not contribute with, insurance provided by this policy."

Each insurance policy shall be written by insurance companies licensed to do business in the State or meet Section 431:8-301, Hawaii Revised Statutes, if utilizing an insurance company not licensed by the State of Hawaii.

The Contractor agrees to deposit with the State of Hawaii, on or before the effective date of this contract, certificate(s) of insurance necessary to satisfy the State that the insurance provisions of this contract have been complied with and to keep such insurance in effect and the certificate(s) therefor on deposit with the State during the entire term of this contract. Upon request by the State, Contractor shall furnish a copy of the policy or policies.

Failure of the Contractor to provide and keep in force such insurance shall be regarded as material default under this contract, entitling the State to exercise any or all of the remedies provided in this contract for a default of the Contractor.

The procuring of such required policy or policies of insurance shall not be construed to limit Contractor's liability hereunder nor to fulfill the indemnification provisions and requirements of this contract. Notwithstanding said policy or policies of insurance, Contractor shall be obliged for the full and total amount of any damage, injury, or loss caused by negligence or neglect or willful misconduct connected with this contract.

### INVOICING

Contractor shall send an original and three (3) copies of the invoice(s) to:

Department of Land and Natural Resources  
Bureau Of Converyances  
1151 Punchbowl Street, Rom 120  
Honolulu, Hawaii 96813

Attention: Mr. Carl Watanabe  
Telephone: (808) 587-0120

## APPENDIX B

---

### RATE OF WAGES & WAGE CERTIFICATE

- a. Section 103-55, HRS. Refer to the General Terms and Conditions. Contractor shall complete and submit the attached Wage Certificate by which contractor certifies that the services required will be performed pursuant to Section 103-55, HRS.

At the time of this solicitation, although there are no public employee positions listed in the classification plan of the public sector that are similar to Offeror's network installers, Offeror must sign the Wage Certificate to show compliance with Section No. 2 of the certificate.

Work described in this RFP shall be performed by employees paid in accordance with the requirements of Chapter 104, HRS (see subsection b below).

- b. Chapter 104, HRS. The latest minimum wage rates as promulgated by the Department of Labor and Industrial Relations shall be paid to the various classes of Electrician engaged in the performance of this contract on the job site (if Offeror engages the services of an Electrician for this project). All work shall be done in accordance with Attachment A to this RFP. Reference is made to Chapter 104, HRS, Wages and Hours of Employees on Public Works.

## APPENDIX B

---

## ATTACHMENTS

---

## APPENDIX B

---

### ATTACHMENT A

#### REQUIREMENTS OF CHAPTER 104, HRS WAGES AND HOURS OF EMPLOYEES ON PUBLIC WORKS

Pursuant to Chapter 104, HRS, the minimum wages that shall be paid to the various classes of laborers and mechanics engaged in the performance of the contract on the job site shall be in accordance with the attached schedule of wages promulgated by the director of the Department of Labor and Industrial Relations.

The minimum wages shall be periodically increased during the performance of the contract in an amount equal to the increase in the prevailing wages for those kinds of work as periodically determined by the director of labor and industrial relations.

No laborer or mechanic employed on the job site of any public work of the State or any political subdivision thereof shall be permitted or required to work on Saturday, Sunday, or a legal holiday of the State or in excess of eight hours on any other day unless the laborer or mechanic receives overtime compensation for all hours worked on Saturday, Sunday, and a legal holiday of the State or in excess of eight hours on any other day. For purposes of determining overtime compensation, the basic hourly rate of any laborer or mechanic shall not be less than the basic hourly rate determined by the director to be the prevailing basic hourly rate for corresponding classes of laborers and mechanics on projects of similar character in the State.

The contractor or the contractor's subcontractor shall pay all mechanics and laborers (listed on the attached schedule) employed on the job site, unconditionally and not less often than once a week, and without deduction or rebate on any account, except as allowed by law, the full amounts of their wages including overtime, accrued to not more than five working days prior to the time of payment, at wage rates not less than those stated in the contract and specifications, regardless of any contractual relationship which may be alleged to exist between the contractor or subcontractor and the laborers and mechanics.

The rates of wages to be paid shall be posted by the contractor in a prominent and easily accessible place at the job site. A copy of the rates of wages shall be given to each laborer and mechanic employed under the contract by the contractor at the time each laborer and mechanic is employed, provided that where there is a collective bargaining agreement the contractor does not have to provide the contract's employees the wage rate schedules.

The governmental contracting agency may withhold from the contractor so much of the accrued payments as the governmental contracting agency may consider necessary to pay to laborers and mechanics employed by the contractor or any subcontractor on the job site the difference between the wages required by the contract or specifications and the wages received and not refunded by the laborers and mechanics.

A certified copy of all payrolls shall be submitted weekly to the governmental contracting agency. The general contractor shall be responsible for the submission of certified copies of the payrolls of all subcontractors. The certification shall affirm that the payrolls are correct and complete, that the wage rates contained therein are not less than the applicable rates contained in the wage determination decision of the director of labor and industrial relations attached to the contract, and that the classifications set forth for each laborer or mechanic conform with the work the laborer or mechanic performed.

## APPENDIX B

---

Payroll records for all laborers and mechanics working at the site of the work shall be maintained by the contractor and the subcontractors, if any, during the course of the work and preserved for a period of three years thereafter. The records shall contain the name of each employee, the employee's correct classification, rate of pay, daily and weekly number of hours worked, deductions made and actual wages paid. The records shall be made available for inspection by the purchasing agency, director, and any authorized representatives thereof who may also interview employees during working hours on the job.

If the purchasing agency finds that any laborer or mechanic employed on the job site by the contractor or any subcontractor has been or is being paid wages at a rate less than the required rate by the contract or the specifications, or has not received the laborer's or mechanic's full overtime compensation, the purchasing agency may, by written notice to the contractor, terminate the contractor's right, or the right of any subcontractor, to proceed with the work or with the part of the work in which the required wages or overtime compensation have not been paid and may complete such work or part by contract or otherwise, and the contractor and the contractor's sureties (if any) shall be liable to the purchasing agency for any excess costs occasioned thereby.

# WAGE CERTIFICATE

(For Service Contracts)

Subject: IFB/RFP No.: ICS-FY-99-52

Title of IFB/RFP: Services to Develop and Implement  
a Replacement Land Court and Regular Automated  
Tracking System, Dept. of Land & Natural Resources  
(To be completed by offeror)

Pursuant to Section 103-55, Hawaii Revised Statutes (HRS), I hereby certify that I awarded the contract in excess of \$25,000, the services to be performed will be performed under the following conditions:

1. All applicable laws of the federal and state governments relating to workers' compensation, unemployment compensation, payment of wages, and safety will be fully complied with; and
2. The services to be rendered shall be performed by employees paid at wages or salaries not less than the wages paid to public officers and employees for similar work, with the exception of professional, managerial, supervisory, and clerical personnel who are not covered by Section 103-55, HRS.

I understand that failure to comply with the above conditions during the period of the contract shall result in cancellation of the contract, unless such noncompliance is corrected within a reasonable period as determined by the procurement officer. Payment in the final settlement of the contract or the release of bonds, if applicable, or both shall not be made unless the procurement officer has determined that the noncompliance has been corrected; and

I further understand that all payments required by Federal and State laws to be made by employers for the benefit of their employees are to be paid in addition to the base wage required by section 103-55, HRS.

Offeror Unique Computer Systems, Inc.  
dba THE LANGE GROUP

Signature 

Title President

Date January 26, 2000

500660

# GENERAL CONDITIONS

## Table of Contents

	<u>Page(s)</u>
1. <u>Coordination of Services by the STATE</u> .....	1
2. <u>Relationship of Parties: Independent Contractor Status and Responsibilities, Including Tax Responsibilities</u> .....	1
3. <u>Personnel Requirements</u> .....	2
4. <u>Nondiscrimination</u> .....	2
5. <u>Conflicts of Interest</u> .....	2
6. <u>Subcontracts and Assignments</u> .....	3
7. <u>Indemnification and Defense</u> .....	4
8. <u>Cost of Litigation</u> .....	4
9. <u>Liquidated Damages</u> .....	4
10. <u>State's Right of Offset</u> .....	4
11. <u>Disputes</u> .....	5
12. <u>Suspension of Agreement</u> .....	5
13. <u>Termination for Default</u> .....	6
14. <u>Termination for Convenience</u> .....	8
15. <u>Claims Based on the Agency Procurement Officer's Actions or Omissions</u> .....	10
16. <u>Costs and Expenses</u> .....	11
17. <u>Payment Procedures: Final Payment: Tax Clearance</u> .....	12
18. <u>Federal Funds</u> .....	12

19.	<u>Modifications of Agreement</u> .....	12
20.	<u>Change Order</u> .....	14
21.	<u>Price Adjustment</u> .....	15
22.	<u>Variation in Quantity for Definite Quantity Agreements</u> .....	16
23.	<u>Changes in Cost-Reimbursement Agreement</u> .....	16
24.	<u>Confidentiality of Material</u> .....	17
25.	<u>Publicity</u> .....	17
26.	<u>Ownership Rights and Copyright</u> .....	17
27.	<u>Liens and Warranties</u> .....	17
28.	<u>Audit of Books and Records of the CONTRACTOR</u> .....	18
29.	<u>Cost or Pricing Data</u> .....	18
30.	<u>Audit of Cost or Pricing Data</u> .....	18
31.	<u>Records Retention</u> .....	18
32.	<u>Antitrust Claims</u> .....	18
33.	<u>Minimizing Congestion</u> .....	18
34.	<u>Governing Law</u> .....	18
35.	<u>Compliance with Laws</u> .....	19
36.	<u>Conflict between General Conditions and Procurement Rules</u> .....	19
37.	<u>Entire Agreement</u> .....	19
38.	<u>Severability</u> .....	19
39.	<u>Waiver</u> .....	19



## GENERAL CONDITIONS

1. Coordination of Services by the STATE. The "head of the purchasing agency," (which term includes the designee of the head of the purchasing agency), shall coordinate the services to be provided by the CONTRACTOR in order to complete the performance required in the Agreement. The CONTRACTOR shall maintain communications with the head of the purchasing agency at all stages of the CONTRACTOR's work, and submit to the head of the purchasing agency for resolution any questions which may arise as to the performance of this Agreement. "Purchasing agency" as used in these General Conditions means and includes any governmental body which is authorized under chapter 103D, HRS, or its implementing rules and procedures, or by way of delegation, to enter into contracts for the procurement of services.
  
2. Relationship of Parties: Independent Contractor Status and Responsibilities, Including Tax Responsibilities.
  - a. In the performance of services required under this Agreement, the CONTRACTOR is an "independent contractor," with the authority and responsibility to control and direct the performance and details of the work and services required under this Agreement; however, the STATE shall have a general right to inspect work in progress to determine whether, in the STATE's opinion, the services are being performed by the CONTRACTOR in compliance with this Agreement. Unless otherwise provided by special condition, it is understood that the STATE does not agree to use the CONTRACTOR exclusively, and that the CONTRACTOR is free to contract to provide services to other individuals or entities while under contract with the STATE.
  
  - b. The CONTRACTOR and the CONTRACTOR's employees and agents are not by reason of this Agreement, agents or employees of the State for any purpose, and the CONTRACTOR and the CONTRACTOR's employees and agents shall not be entitled to claim or receive from the State any vacation, sick leave, retirement, workers' compensation, unemployment insurance, or other benefits provided to state employees.
  
  - c. The CONTRACTOR shall be responsible for the accuracy, completeness, and adequacy of the CONTRACTOR's performance under this Agreement. Furthermore, the CONTRACTOR intentionally, voluntarily, and knowingly assumes the sole and entire liability to the CONTRACTOR's employees and agents, and to any individual not a party to this Agreement, for all loss, damage, or injury caused by the CONTRACTOR, or the CONTRACTOR's employees or agents in the course of their employment.

- d. The CONTRACTOR shall be responsible for payment of all applicable federal, state, and county taxes and fees which may become due and owing by the CONTRACTOR by reason of this Agreement, including but not limited to (i) income taxes, (ii) employment related fees, assessments, and taxes, and (iii) general excise taxes. The CONTRACTOR also is responsible for obtaining all licenses, permits, and certificates that may be required in order to perform this Agreement.
- e. The CONTRACTOR shall obtain a general excise tax license from the Department of Taxation, State of Hawaii, in accordance with section 237-9, HRS, and shall comply with all requirements thereof. The CONTRACTOR shall obtain a tax clearance certificate from the Director of Taxation, State of Hawaii, showing that all delinquent taxes, if any, levied or accrued under state law against the CONTRACTOR have been paid and submit the same to the STATE prior to commencing any performance under this Agreement. The CONTRACTOR shall also be solely responsible for meeting all requirements necessary to obtain the tax clearance certificate required for final payment under sections 103-53 and 237-45, HRS, and paragraph 17 of these General Conditions.
- f. The CONTRACTOR is responsible for securing all employee-related insurance coverage for the CONTRACTOR and the CONTRACTOR's employees and agents that is or may be required by law, and for payment of all premiums, costs, and other liabilities associated with securing the insurance coverage.

3. Personnel Requirements.

- a. The CONTRACTOR shall secure, at the CONTRACTOR's own expense, all personnel required to perform this Agreement.
- b. The CONTRACTOR shall ensure that the CONTRACTOR's employees or agents are experienced and fully qualified to engage in the activities and perform the services required under this Agreement, and that all applicable licensing and operating requirements imposed or required under federal, state, or county law, and all applicable accreditation and other standards of quality generally accepted in the field of the activities of such employees and agents are complied with and satisfied.

4. Nondiscrimination. No person performing work under this Agreement, including any subcontractor, employee, or agent of the CONTRACTOR, shall engage in any discrimination that is prohibited by any applicable federal, state, or county law.

5. Conflicts of Interest. The CONTRACTOR represents that neither the CONTRACTOR, nor any employee or agent of the CONTRACTOR, presently has any interest, and promises that no such interest, direct or indirect, shall be acquired, that would or might

conflict in any manner or degree with the CONTRACTOR's performance under this Agreement.

6. Subcontracts and Assignments. The CONTRACTOR shall not assign or subcontract any of the CONTRACTOR's duties, obligations, or interests under this Agreement and no such assignment or subcontract shall be effective unless (i) the CONTRACTOR obtains the prior written consent of the STATE and (ii) the CONTRACTOR's assignee or subcontractor submits to the STATE a tax clearance certificate from the Director of Taxation, State of Hawaii, showing that all delinquent taxes, if any, levied or accrued under state law against the CONTRACTOR's assignee or subcontractor have been paid. Additionally, no assignment by the CONTRACTOR of the CONTRACTOR's right to compensation under this Agreement shall be effective unless and until the assignment is approved by the Comptroller of the State of Hawaii, as provided in section 40-58, HRS.
- a. Recognition of a successor in interest. When in the best interest of the State, a successor in interest may be recognized in an assignment agreement in which the STATE, the CONTRACTOR and the assignee or transferee (hereinafter referred to as the "Assignee") agree that:
- (1) The Assignee assumes all of the CONTRACTOR's obligations;
  - (2) The CONTRACTOR remains liable for all obligations under this Agreement but waives all rights under this Agreement as against the STATE; and
  - (3) The CONTRACTOR shall continue to furnish, and the Assignee shall also furnish, all required bonds.
- b. Change of name. When the CONTRACTOR asks to change the name in which it holds this Agreement with the STATE, the procurement officer of the purchasing agency (hereinafter referred to as the "Agency procurement officer") shall, upon receipt of a document acceptable or satisfactory to the Agency procurement officer indicating such change of name (for example, an amendment to the CONTRACTOR's articles of incorporation), enter into an amendment to this Agreement with the CONTRACTOR to effect such a change of name. The amendment to this Agreement changing the CONTRACTOR's name shall specifically indicate that no other terms and conditions of this Agreement are thereby changed.
- c. Reports. All assignment agreements and amendments to this Agreement effecting changes of the CONTRACTOR's name or novations hereunder shall be reported to the CPO within thirty days of the date that the assignment agreement or amendment becomes effective.

- d. Actions affecting more than one purchasing agency. Notwithstanding the provisions of subparagraphs 6a through 6c herein, when the CONTRACTOR holds agreements with more than one purchasing agency of the State, the assignment agreements and the novation and change of name amendments herein authorized shall be processed only through the CPO's office.
7. Indemnification and Defense. The CONTRACTOR shall defend, indemnify, and hold harmless the State of Hawaii, the contracting agency, and their officers, employees, and agents from and against all liability, loss, damage, cost, and expense, including all attorneys' fees, and all claims, suits, and demands therefor, arising out of or resulting from the acts or omissions of the CONTRACTOR or the CONTRACTOR's employees, officers, agents, or subcontractors under this Agreement. The provisions of this paragraph shall remain in full force and effect notwithstanding the expiration or early termination of this Agreement.
8. Cost of Litigation. In case the STATE shall, without any fault on its part, be made a party to any litigation commenced by or against the CONTRACTOR in connection with this Agreement, the CONTRACTOR shall pay all costs and expenses incurred by or imposed on the STATE, including attorneys' fees.
9. Liquidated Damages. When the CONTRACTOR is given notice of delay or nonperformance as specified in paragraph 13 (Termination for Default) and fails to cure in the time specified, it is agreed the CONTRACTOR shall pay to the STATE the amount, if any, set forth in this Agreement per calendar day from the date set for cure until either (i) the STATE reasonably obtains similar goods or services, or both, if the CONTRACTOR is terminated for default, or (ii) until the CONTRACTOR provides the goods or services, or both, if the CONTRACTOR is not terminated for default. To the extent that the CONTRACTOR's delay or nonperformance is excused under paragraph 13d (Excuse for Nonperformance or Delay Performance), liquidated damages shall not be assessable against the CONTRACTOR. The CONTRACTOR shall remain liable for damages caused other than by delay.
10. State's Right of Offset. The STATE may offset against any monies or other obligations the STATE owes to the CONTRACTOR under this Agreement, any amounts owed to the State of Hawaii by the CONTRACTOR under this Agreement or any other agreements or pursuant to any law or other obligation owed to the State of Hawaii by the CONTRACTOR, including, without limitation, the payment of any taxes or levies of any kind or nature. The STATE will notify the CONTRACTOR in writing of any offset and the nature of such offset. For purposes of this paragraph, amounts owed to the State of Hawaii shall not include debts or obligations which have been liquidated, agreed to by the CONTRACTOR, and are covered by an installment payment or other settlement plan approved by the State of Hawaii, provided, however, that the CONTRACTOR shall be entitled to such exclusion only to the extent that the CONTRACTOR is current with, and

not delinquent on, any payments or obligations owed to the State of Hawaii under such payment or other settlement plan.

11. Disputes. Disputes shall be resolved in accordance with section 103D-703, HRS, and chapter 126, Procurement Rules, as the same may be amended from time to time.
12. Suspension of Agreement. The STATE reserves the right at any time and for any reason to suspend this Agreement for any reasonable period, upon written notice to the CONTRACTOR in accordance with the provisions herein.
  - a. Order to stop performance. The Agency procurement officer, may, by written order to the CONTRACTOR, at any time, and without notice to any surety, require the CONTRACTOR to stop all or any part of the performance called for by this Agreement. This order shall be for a specified period not exceeding sixty (60) days after the order is delivered to the CONTRACTOR, unless the parties agree to any further period. Any such order shall be identified specifically as a stop performance order issued pursuant to this section. Upon receipt of such an order, the CONTRACTOR shall forthwith comply with its terms and suspend all performance under this Agreement at the time stated, provided, however, the CONTRACTOR shall take all reasonable steps to minimize the occurrence of costs allocable to the performance covered by the order during the period of performance stoppage. Before the stop performance order expires, or within any further period to which the parties shall have agreed, the Agency procurement officer shall either:
    - (1) Cancel the stop performance order; or
    - (2) Terminate the performance covered by such order as provided in the termination for default provision or the termination for convenience provision of this Agreement.
  - b. Cancellation or expiration of the order. If a stop performance order issued under this section is cancelled at any time during the period specified in the order, or if the period of the order or any extension thereof expires, the CONTRACTOR shall have the right to resume performance. An appropriate adjustment shall be made in the delivery schedule or Agreement price, or both, and the Agreement shall be modified in writing accordingly, if:
    - (1) The stop performance order results in an increase in the time required for, or in the CONTRACTOR's cost properly allocable to, the performance of any part of this Agreement; and
    - (2) The CONTRACTOR asserts a claim for such an adjustment within thirty (30) days after the end of the period of performance stoppage; provided

that, if the Agency procurement officer decides that the facts justify such action, any such claim asserted may be received and acted upon at any time prior to final payment under this Agreement.

- c. Termination of stopped performance. If a stop performance order is not cancelled and the performance covered by such order is terminated for default or convenience, the reasonable costs resulting from the stop performance order shall be allowable by adjustment or otherwise.
- d. Adjustment of price. Any adjustment in contract price made pursuant to this paragraph shall be determined in accordance with the price adjustment provision of this Agreement.

13. Termination for Default.

- a. Default. If the CONTRACTOR refuses or fails to perform any of the provisions of this Agreement with such diligence as will ensure its completion within the time specified in this Agreement, or any extension thereof, otherwise fails to timely satisfy the Agreement provisions, or commits any other substantial breach of this Agreement, the Agency procurement officer may notify the CONTRACTOR in writing of the delay or non-performance and if not cured in ten (10) days or any longer time specified in writing by the Agency procurement officer, such officer may terminate the CONTRACTOR's right to proceed with the Agreement or such part of the Agreement as to which there has been delay or a failure to properly perform. In the event of termination in whole or in part the Agency procurement officer may procure similar goods or services in a manner and upon the terms deemed appropriate by the Agency procurement officer. The CONTRACTOR shall continue performance of the Agreement to the extent it is not terminated and shall be liable for excess costs incurred in procuring similar goods or services.
- b. CONTRACTOR's duties. Notwithstanding termination of the Agreement and subject to any directions from the Agency procurement officer, the CONTRACTOR shall take timely, reasonable, and necessary action to protect and preserve property in the possession of the CONTRACTOR in which the STATE has an interest.
- c. Compensation. Payment for completed goods and services delivered and accepted by the STATE shall be at the price set forth in the Agreement. Payment for the protection and preservation of property shall be in an amount agreed upon by the CONTRACTOR and the Agency procurement officer. If the parties fail to agree, the Agency procurement officer shall set an amount subject to the CONTRACTOR's rights under chapter 126, Procurement Rules. The STATE may withhold from amounts due the CONTRACTOR such sums as the Agency

procurement officer deems to be necessary to protect the STATE against loss because of outstanding liens or claims and to reimburse the STATE for the excess costs expected to be incurred by the STATE in procuring similar goods and services.

- d. Excuse for nonperformance or delayed performance. The CONTRACTOR shall not be in default by reason of any failure in performance of this Agreement in accordance with its terms, including any failure by the CONTRACTOR to make progress in the prosecution of the performance hereunder which endangers such performance, if the CONTRACTOR has notified the Agency procurement officer within fifteen (15) days after the cause of the delay and the failure arises out of causes such as: acts of God; acts of a public enemy; acts of the State and any other governmental body in its sovereign or contractual capacity; fires; floods; epidemics; quarantine restrictions; strikes or other labor disputes; freight embargoes; or unusually severe weather. If the failure to perform is caused by the failure of a subcontractor to perform or to make progress, and if such failure arises out of causes similar to those set forth above, the CONTRACTOR shall not be deemed to be in default, unless the goods and services to be furnished by the subcontractor were reasonably obtainable from other sources in sufficient time to permit the CONTRACTOR to meet the requirements of the Agreement. Upon request of the CONTRACTOR, the Agency procurement officer shall ascertain the facts and extent of such failure, and, if such officer determines that any failure to perform was occasioned by any one or more of the excusable causes, and that, but for the excusable cause, the CONTRACTOR's progress and performance would have met the terms of the Agreement, the delivery schedule shall be revised accordingly, subject to the rights of the STATE under this Agreement. As used in this paragraph, the term "subcontractor" means subcontractor at any tier.
- e. Erroneous termination for default. If, after notice of termination of the CONTRACTOR's right to proceed under this paragraph, it is determined for any reason that the CONTRACTOR was not in default under this paragraph, or that the delay was excusable under the provisions of subparagraph 13d, "Excuse for nonperformance or delayed performance," the rights and obligations of the parties shall be the same as if the notice of termination had been issued pursuant to such provision.
- f. Additional rights and remedies. The rights and remedies provided in this paragraph are in addition to any other rights and remedies provided by law or under this Agreement.

14. Termination for Convenience.

- a. Termination. The Agency procurement officer may, when the interests of the STATE so require, terminate this Agreement in whole or in part, for the convenience of the STATE. The Agency procurement officer shall give written notice of the termination to the CONTRACTOR specifying the part of the Agreement terminated and when termination becomes effective.
- b. CONTRACTOR's obligations. The CONTRACTOR shall incur no further obligations in connection with the terminated performance and on the date(s) set in the notice of termination the CONTRACTOR will stop performance to the extent specified. The CONTRACTOR shall also terminate outstanding orders and subcontracts as they relate to the terminated performance. The CONTRACTOR shall settle the liabilities and claims arising out of the termination of subcontracts and orders connected with the terminated performance. The Agency procurement officer may direct the CONTRACTOR to assign the CONTRACTOR's right, title, and interest under terminated orders or subcontracts to the STATE. The CONTRACTOR must still complete the performance not terminated by the notice of termination and may incur obligations as necessary to do so.
- c. Right to goods and work product. The Agency procurement officer may require the CONTRACTOR to transfer title and deliver to the STATE in the manner and to the extent directed by the Agency procurement officer:
- (1) Any completed goods or work product; and
  - (2) The partially completed goods and materials, parts, tools, dies, jigs, fixtures, plans, drawings, information, and contract rights (hereinafter called "manufacturing material") as the CONTRACTOR has specifically produced or specially acquired for the performance of the terminated part of this Agreement.

The CONTRACTOR shall, upon direction of the Agency procurement officer, protect and preserve property in the possession of the CONTRACTOR in which the STATE has an interest. If the Agency procurement officer does not exercise this right, the CONTRACTOR shall use best efforts to sell such goods and manufacturing materials. Use of this paragraph in no way implies that the STATE has breached the Agreement by exercise of the termination for convenience provision.

d. Compensation.

- (1) The CONTRACTOR shall submit a termination claim specifying the amounts due because of the termination for convenience together with the



cost or pricing data, submitted to the extent required by subchapter 15, chapter 3-122, Procurement Rules, bearing on such claim. If the CONTRACTOR fails to file a termination claim within one year from the effective date of termination, the Agency procurement officer may pay the CONTRACTOR, if at all, an amount set in accordance with subparagraph 14d(3) below.

- (2) The Agency procurement officer and the CONTRACTOR may agree to a settlement provided the CONTRACTOR has filed a termination claim supported by cost or pricing data submitted as required and that the settlement does not exceed the total Agreement price plus settlement costs reduced by payments previously made by the STATE, the proceeds of any sales of goods and manufacturing materials under subparagraph 14c, and the Agreement price of the performance not terminated.
- (3) Absent complete agreement under subparagraph 14d(2) the Agency procurement officer shall pay the CONTRACTOR the following amounts, provided payments agreed to under subparagraph 14d(2) shall not duplicate payments under this subparagraph for the following:
  - (A) Contract prices for goods or services accepted under the Agreement;
  - (B) Costs incurred in preparing to perform and performing the terminated portion of the performance plus a fair and reasonable profit on such portion of the performance, such profit shall not include anticipatory profit or consequential damages, less amounts paid or to be paid for accepted goods or services; provided, however, that if it appears that the CONTRACTOR would have sustained a loss if the entire Agreement would have been completed, no profit shall be allowed or included and the amount of compensation shall be reduced to reflect the anticipated rate of loss;
  - (C) Costs of settling and paying claims arising out of the termination of subcontracts or orders pursuant to subparagraph 14b. These costs must not include costs paid in accordance with subparagraph 14d(3)(B);
  - (D) The reasonable settlement costs of the CONTRACTOR including accounting, legal, clerical, and other expenses reasonably necessary for the preparation of settlement claims and supporting data with respect to the terminated portion of the Agreement and for the termination of subcontracts thereunder, together with

reasonable storage, transportation, and other costs incurred in connection with the protection or disposition of property allocable to the terminated portion of this Agreement. The total sum to be paid the CONTRACTOR under this subparagraph shall not exceed the total Agreement price plus the reasonable settlement costs of the CONTRACTOR reduced by the amount of payments otherwise made, the proceeds of any sales of supplies and manufacturing materials under subparagraph 14d(2), and the Agreement price of performance not terminated.

- (4) Costs claimed, agreed to, or established under subparagraphs 14d(2) and 14d(3) shall be in accordance with Chapter 3-123 (Cost Principles) of the Procurement Rules.

15. Claims Based on the Agency Procurement Officer's Actions or Omissions.

- a. Changes in scope. If any action or omission on the part of the Agency procurement officer (which term includes the designee of such officer for purposes of this paragraph 15) requiring performance changes within the scope of the Agreement constitutes the basis for a claim by the CONTRACTOR for additional compensation, damages, or an extension of time for completion, the CONTRACTOR shall continue with performance of the Agreement in compliance with the directions or orders of such officials, but by so doing, the CONTRACTOR shall not be deemed to have prejudiced any claim for additional compensation, damages, or an extension of time for completion; provided:
  - (1) Written notice required. The CONTRACTOR shall give written notice to the Agency procurement officer:
    - (A) Prior to the commencement of the performance involved, if at that time the CONTRACTOR knows of the occurrence of such action or omission;
    - (B) Within thirty (30) days after the CONTRACTOR knows of the occurrence of such action or omission, if the CONTRACTOR did not have such knowledge prior to the commencement of the performance; or
    - (C) Within such further time as may be allowed by the Agency procurement officer in writing.
  - (2) Notice content. This notice shall state that the CONTRACTOR regards the act or omission as a reason which may entitle the CONTRACTOR to additional compensation, damages, or an extension of time. The Agency

procurement officer, upon receipt of such notice, may rescind such action, remedy such omission, or take such other steps as may be deemed advisable in the discretion of the Agency procurement officer;

- (3) Basis must be explained. The notice required by subparagraph 15a(1) describes as clearly as practicable at the time the reasons why the CONTRACTOR believes that additional compensation, damages, or an extension of time may be remedies to which the CONTRACTOR is entitled; and
  - (4) Claim must be justified. The CONTRACTOR must maintain and, upon request, make available to the Agency procurement officer within a reasonable time, detailed records to the extent practicable, and other documentation and evidence satisfactory to the STATE, justifying the claimed additional costs or an extension of time in connection with such changes.
- b. CONTRACTOR not excused. Nothing herein contained, however, shall excuse the CONTRACTOR from compliance with any rules or laws precluding any state officers and CONTRACTOR from acting in collusion or bad faith in issuing or performing change orders which are clearly not within the scope of the Agreement.
  - c. Price adjustment. Any adjustment in the price made pursuant to this paragraph shall be determined in accordance with the price adjustment provision of this Agreement.
16. Costs and Expenses. Any reimbursement due the CONTRACTOR for per diem and transportation expenses under this Agreement shall be subject to chapter 3-123 (Cost Principles) of the Procurement Rules and the following guidelines:
- a. Reimbursement for air transportation shall be for actual cost or coach class air fare, whichever is less.
  - b. Reimbursement for ground transportation costs shall not exceed the actual cost of renting an intermediate-sized vehicle.
  - c. Unless prior written approval of the DIRECTOR is obtained, reimbursement for subsistence allowance (i.e., hotel and meals, etc.) shall not exceed the applicable daily authorized rates for interisland or out-of-state travel that are set forth in the current Governor's Executive Order authorizing adjustments in salaries and benefits for state officers and employees in the executive branch who are excluded from collective bargaining coverage.

17. Payment Procedures: Final Payment: Tax Clearance.

- a. Original invoices required. All payments under this Agreement shall be made only upon submission by the CONTRACTOR of original invoices specifying the amount due and certifying that services requested under the Agreement have been performed by the CONTRACTOR according to the Agreement.
- b. Subject to available funds. Such payments are subject to availability of funds and allotment by the Director of Finance in accordance with chapter 37, HRS. Further, all payments shall be made in accordance with and subject to chapter 40, HRS.
- c. Prompt payment.
  - (1) Any money, other than retainage, paid to the CONTRACTOR shall be dispersed to subcontractors within ten days after receipt of the money in accordance with the terms of the subcontract; provided that the subcontractor has met all the terms and conditions of the subcontract and there are no bona fide disputes; and
  - (2) Upon final payment to the CONTRACTOR, full payment to the subcontractor, including retainage, shall be made within ten days after receipt of the money; provided that there are no bona fide disputes over the subcontractor's performance under the subcontract.
- d. Final payment. Final payment under this Agreement shall be subject to sections 103-53 and 237-45, HRS, which require a tax clearance from the Director of Taxation, State of Hawaii, showing that all delinquent taxes, if any, levied or accrued under state law against the CONTRACTOR have been paid.

18. Federal Funds. If this Agreement is payable in whole or in part from federal funds, CONTRACTOR agrees that, as to the portion of the compensation under this Agreement to be payable from federal funds, the CONTRACTOR shall be paid only from such funds received from the federal government, and shall not be paid from any other funds.

19. Modifications of Agreement.

- a. In writing. Any modification, alteration, amendment, change, or extension of any term, provision, or condition of this Agreement permitted by this Agreement shall be made by written amendment to this Agreement, signed by the

CONTRACTOR and the STATE, provided that change orders shall be made in accordance with paragraph 20 herein.

- b. No oral modification. No oral modification, alteration, amendment, change, or extension of any term, provision or condition of this Agreement shall be permitted.
- c. Agency procurement officer. By a written order, at any time, and without notice to any surety, the Agency procurement officer, subject to mutual agreement of the parties to this Agreement and all appropriate adjustments, may make modifications within the general scope of this Agreement to include any one or more of the following:
  - (A) Drawings, designs, or specifications;
  - (B) Method or place of delivery;
  - (C) Description of services to be performed;
  - (D) Time of performance (i.e., hours of the day, days of the week, etc.);
  - (E) Place of performance of the services; or
  - (F) Other provisions of the Agreement accomplished by mutual action of the parties to the Agreement.
- d. Adjustments of price or time for performance. If any modification increases or decreases the CONTRACTOR's cost of, or the time required for, performance of any part of the work under this Agreement, an adjustment shall be made and this Agreement modified in writing accordingly. Any adjustment in Agreement price made pursuant to this clause shall be determined, where applicable, in accordance with the price adjustment clause of this Agreement or as negotiated.
- e. Claim barred after final payment. No claim by the CONTRACTOR for an adjustment hereunder shall be allowed if written agreement of modification is not made prior to final payment under this Agreement.
- f. Claims not barred. In the absence of an Agreement modification, nothing in this clause shall be deemed to restrict the CONTRACTOR's right to pursue a claim under this Agreement or for a breach of contract.
- g. CPO approval. If a modification, alteration, amendment, change or extension of any term, provision or condition of this Agreement increases the amount payable to the CONTRACTOR by at least \$25,000.00 or ten per cent (10%) of the initial

Agreement price, whichever increase is higher, the prior approval of the CPO is required.

- h. Tax clearance. The STATE may, at its discretion, require the CONTRACTOR to submit to the STATE, prior to the STATE's approval of any modification, alteration, amendment, change, or extension of any term, provision, or condition of this Agreement, a tax clearance from the Director of Taxation, State of Hawaii, showing that all delinquent taxes, if any, levied or accrued under state law against the CONTRACTOR have been paid.
- i. Sole source agreements. Amendments to sole source agreements that would change the original scope of the contract may only be made with the approval of the CPO. Annual renewal of a sole source agreement for services should not be submitted as an amendment.

20. Change Order. The Agency procurement officer may, by a written order signed only by the STATE, at any time, and without notice to any surety, and subject to all appropriate adjustments, make changes within the general scope of this Agreement in any one or more of the following:

- (1) Drawings, designs, or specifications, if the goods or services to be furnished are to be specially provided to the STATE in accordance therewith;
  - (2) Method of delivery; or
  - (3) Place of delivery.
- a. Adjustments of price or time for performance. If any change order increases or decreases the CONTRACTOR's cost of, or the time required for, performance of any part of the work under this Agreement, whether or not changed by the order, an adjustment shall be made and the Agreement modified in writing accordingly. Any adjustment in the Agreement price made pursuant to this provision shall be determined in accordance with the price adjustment provision of this Agreement. Failure of the parties to agree to an adjustment shall not excuse the CONTRACTOR from proceeding with the Agreement as changed, provided that the Agency procurement officer promptly and duly makes the provisional adjustments in payment or time for performance as may be reasonable. By proceeding with the work, the CONTRACTOR shall not be deemed to have prejudiced any claim for additional compensation, or any extension of time for completion.
  - b. CPO approval. If a contract change order increases the amount payable to the CONTRACTOR by at least \$25,000.00 or ten per cent (10%) of the initial

Agreement price, whichever increase is higher, the prior approval of the CPO is required.

- c. Time period for claim. Within thirty (30) days after receipt of a written change order under subparagraph 20a, unless the period is extended by the Agency procurement officer in writing, the CONTRACTOR shall file notice of intent to assert a claim for an adjustment. Later notification shall not bar the CONTRACTOR's claim unless the STATE is prejudiced by the delay in notification.
- d. Claim barred after final payment. No claim by the CONTRACTOR for an adjustment hereunder shall be allowed if notice is not given prior to final payment under this Agreement.
- e. Other claims not barred. In the absence of a change order, nothing in this paragraph 20 shall be deemed to restrict the CONTRACTOR's right to pursue a claim under the Agreement or for breach of contract.

21. Price Adjustment.

- a. Price adjustment. Any adjustment in the Agreement price pursuant to a provision in this Agreement shall be made in one or more of the following ways:
  - (1) By agreement on a fixed price adjustment before commencement of the pertinent performance or as soon thereafter as practicable;
  - (2) By unit prices specified in the Agreement or subsequently agreed upon;
  - (3) By the costs attributable to the event or situation covered by the provision, plus appropriate profit or fee, all as specified in the Agreement or subsequently agreed upon;
  - (4) In such other manner as the parties may mutually agree; or
  - (5) In the absence of agreement between the parties, by a unilateral determination by the Agency procurement officer of the costs attributable to the event or situation covered by the provision, plus appropriate profit or fee, all as computed by the Agency procurement officer in accordance with generally accepted accounting principles and applicable sections of chapters 3-123 and 3-126 of the Procurement Rules.
- b. Submission of cost or pricing data. The CONTRACTOR shall provide cost or pricing data for any price adjustments subject to the provisions of subchapter 15, chapter 3-122 of the Procurement Rules.

22. Variation in Quantity for Definite Quantity Agreements. Upon the agreement of the STATE and the CONTRACTOR, the quantity of goods or services, or both, if a definite quantity is specified in this Agreement, may be increased by a maximum of ten per cent (10%); provided the unit prices will remain the same except for any price adjustments otherwise applicable; and the CPO makes a written determination that such an increase will either be more economical than awarding another Agreement or that it would not be practical to award another Agreement.
23. Changes in Cost-Reimbursement Agreement. If this Agreement is a cost-reimbursement Agreement, the following provisions shall apply:
- a. The Agency procurement officer may at any time by written order, and without notice to the sureties, if any, make changes within the general scope of the Agreement in any one or more of the following:
    - (1) Description of performance (Attachment 1);
    - (2) Time of performance (i.e., hours of the day, days of the week, etc.);
    - (3) Place of performance of services;
    - (4) Drawings, designs, or specifications when the supplies to be furnished are to be specially manufactured for the STATE in accordance with the drawings, designs, or specifications;
    - (5) Method of shipment or packing of supplies; or
    - (6) Place of delivery.
  - b. If any change causes an increase or decrease in the estimated cost of, or the time required for performance of, any part of the performance under this Agreement, whether or not changed by the order, or otherwise affects any other terms and conditions of this Agreement, the Agency procurement officer shall make an equitable adjustment in the (1) estimated cost, delivery or completion schedule, or both; (2) amount of any fixed fee; and (3) other affected terms and shall modify the Agreement accordingly.
  - c. The CONTRACTOR must assert the CONTRACTOR's rights to an adjustment under this provision within thirty (30) days from the day of receipt of the written order. However, if the Agency procurement officer decides that the facts justify it, the Agency procurement officer may receive and act upon a proposal submitted before final payment under the Agreement.



- d. Failure to agree to any adjustment shall be a dispute under paragraph 11 of this Agreement. However, nothing in this provision shall excuse the CONTRACTOR from proceeding with the Agreement as changed.
  - e. Notwithstanding the terms and conditions of subparagraphs 23a and 23b, the estimated cost of this Agreement and, if this Agreement is incrementally funded, the funds allotted for the performance of this Agreement, shall not be increased or considered to be increased except by specific written modification of the Agreement indicating the new Agreement estimated cost and, if this Agreement is incrementally funded, the new amount allotted to the Agreement.
24. Confidentiality of Material.
- a. All material given to or made available to the CONTRACTOR by virtue of this Agreement, which is identified as proprietary or confidential information, will be safeguarded by the CONTRACTOR and shall not be disclosed to any individual or organization without the prior written approval of the STATE.
  - b. All information, data, or other material provided by the CONTRACTOR to the STATE shall be subject to the Uniform Information Practices Act, chapter 92F, HRS.
25. Publicity. The CONTRACTOR shall not refer to the STATE, or any office, agency, or officer thereof, or any State employee, including the head of the purchasing agency, the CPO, the DIRECTOR, the Agency procurement officer, or to the services or goods, or both, provided under this Agreement, in any of the CONTRACTOR's brochures, advertisements, or other publicity of the CONTRACTOR. All media contacts with the CONTRACTOR about the subject matter of this Agreement shall be referred to the Agency procurement officer.
26. Ownership Rights and Copyright. The STATE shall have complete ownership of all material, both finished and unfinished, which is developed, prepared, assembled, or conceived by the CONTRACTOR pursuant to this Agreement, and all such material shall be considered "works made for hire." All such material shall be delivered to the STATE upon expiration or termination of this Agreement. The STATE, in its sole discretion, shall have the exclusive right to copyright any product, concept, or material developed, prepared, assembled, or conceived by the CONTRACTOR pursuant to this Agreement.
27. Liens and Warranties. Goods provided under this Agreement shall be provided free of all liens and provided together with all applicable warranties, or with the warranties described in the Agreement documents, whichever are greater.

28. Audit of Books and Records of the CONTRACTOR. The STATE may, at reasonable times and places, audit the books and records of the CONTRACTOR, prospective contractor, subcontractor or prospective subcontractor which are related to:
- a. The cost or pricing data, and
  - b. A State contract, including subcontracts, other than a firm fixed-price contract.

29. Cost or Pricing Data. Cost or pricing data must be submitted to the Agency purchasing officer and timely certified as accurate for contracts over \$100,000 unless the contract is for a multiple-term or as otherwise specified by the procurement officer. Unless otherwise required by the Agency procurement officer, cost or pricing data submission is not required for agreements awarded pursuant to competitive sealed bid procedures.

If certified cost or pricing data are subsequently found to have been inaccurate, incomplete, or noncurrent as of the date stated in the certificate, the STATE is entitled to an adjustment of the contract price, including profit or fee, to exclude any significant sum by which the price, including profit or fee, was increased because of the defective data. It is presumed that overstated cost or pricing data increased the contract price in the amount of the defect plus related overhead and profit or fee. Therefore, unless there is a clear indication that the defective data was not used or relied upon, the price will be reduced in such amount.

30. Audit of Cost or Pricing Data. When cost or pricing principles are applicable, the STATE may require an audit of cost or pricing data.
31. Records Retention. The CONTRACTOR and any subcontractors shall maintain the books and records that relate to the Agreement and any cost or pricing data for three (3) years from the date of final payment under the Agreement.
32. Antitrust Claims. The STATE and the CONTRACTOR recognize that in actual economic practice, overcharges resulting from antitrust violations are in fact usually borne by the purchaser. Therefore, the CONTRACTOR hereby assigns to STATE any and all claims for overcharges as to goods and materials purchased in connection with this Agreement, except as to overcharges which result from violations commencing after the price is established under this Agreement and which are not passed on to the STATE under an escalation clause.
33. Minimizing Congestion. The CONTRACTOR shall undertake all necessary precautions to minimize any adverse impact the performance under this Agreement may have on traffic congestion.
34. Governing Law. The validity of this Agreement and any of its terms or provisions, as well as the rights and duties of the parties to this Agreement, shall be governed by the

laws of the State of Hawaii. Any action at law or in equity to enforce or interpret the provisions of this Agreement shall be brought in a state court of competent jurisdiction in Honolulu, Hawaii.

35. Compliance with Laws. The CONTRACTOR shall comply with all federal, state, and county laws, ordinances, codes, rules, and regulations, as the same may be amended from time to time, that in any way affect the CONTRACTOR's performance of this Agreement.
36. Conflict between General Conditions and Procurement Rules. In the event of a conflict between the General Conditions and the Procurement Rules, the Procurement Rules in effect on the date this Agreement became effective shall control and are hereby incorporated by reference.
37. Entire Agreement. This Agreement sets forth all of the agreements, conditions, understandings, promises, warranties, and representations between the STATE and the CONTRACTOR relative to this Agreement. This Agreement supersedes all prior agreements, conditions, understandings, promises, warranties, and representations, which shall have no further force or effect. There are no agreements, conditions, understandings, promises, warranties, or representations, oral or written, express or implied, between the STATE and the CONTRACTOR other than as set forth or as referred to herein.
38. Severability. In the event that any provision of this Agreement is declared invalid or unenforceable by a court, such invalidity or unenforceability shall not affect the validity or enforceability of the remaining terms of this Agreement.
39. Waiver. The failure of the STATE to insist upon the strict compliance with any term, provision, or condition of this Agreement shall not constitute or be deemed to constitute a waiver or relinquishment of the STATE's right to enforce the same in accordance with this Agreement. The fact that the STATE specifically refers to one provision of the Procurement Rules or one section of the Hawaii Revised Statutes, and does not include other provisions or statutory sections in this Agreement shall not constitute a waiver or relinquishment of the STATE's rights or the CONTRACTOR's obligations under the Procurement Rules or statutes.

The following provision is a general condition for this Agreement:

If this Agreement was entered into between July 20, 1998, and July 1, 2001, and extends beyond June 30, 2001, it is subject to a single review pursuant to the managed process developed pursuant to part III, section 6 of Act 230, 1998 Haw. Sess. Laws, 785, 787. Pursuant to the managed process review, this Agreement may be cancelled, continued, or extended by the State.

Form AG-GC(1/99)

BENJAMIN J. CAYETANO  
GOVERNOR



RAYMOND H. SATO  
COMPTROLLER

MARY PATRICIA WATERHOUSE  
DEPUTY COMPTROLLER

**STATE OF HAWAII**  
**DEPARTMENT OF ACCOUNTING**  
**AND GENERAL SERVICES**  
P.O. BOX 119  
HONOLULU, HAWAII 96810-0119

December 27, 2000

*Handwritten:*  
1-4-01

Ms. Nani Lindsey  
The Lange Group  
1100 Ward Avenue, Suite 1050  
Honolulu, HI 96814

Dear Ms. Lindsey:

**SUBJECT: ICS-FY-99-52**  
**Services to Develop and Implement a Replacement Land Court**  
**and Regular Automated Tracking System for the State of Hawaii**

Enclosed is a fully executed copy of Supplemental Agreement Number 1 to ICS-FY-99-52, Part 1 for your file.

If you have any questions on this matter, please call Ms. Barbara Tom at (808) 586-1920.

Sincerely,

A handwritten signature in black ink, appearing to read "Lester M. Nakamura".

Lester M. Nakamura  
Administrator

Enclosures

500683

STATE OF HAWAII  
SUPPLEMENTAL AGREEMENT NO. 1  
TO AGREEMENT ICS-FY-99-52  
(Insert Agreement Number or Other Identifying Information)

This Supplemental Agreement No. 1, executed on the respective dates indicated below, is effective as of June 29, ~~XX~~ 2000 between the \_\_\_\_\_

Department of Accounting and General Services, State of Hawaii  
(Insert Name of State Department, Agency, Board or Commission)

(hereinafter "STATE"), by its Comptroller  
(Insert Title of State Officer Executing Agreement)

whose address is 1151 Punchbowl Street, Honolulu, Hawaii 96813

\_\_\_\_\_, and

Unique Computer Systems, Inc. dba The Lange Group (hereinafter "CONTRACTOR"),

a corporation  
(Insert "Corporation", "Partnership", "Joint Venture", "Sole Proprietorship", or other legal form of the Contractor)

under the laws of the State of Hawaii, whose business address and taxpayer

identification number are as follows: 1100 Ward Avenue, Suite 1050, Honolulu, Hawaii

96814; Taxpayer id: 1019306

**RECITALS**

A. WHEREAS, the STATE and the CONTRACTOR entered into an Agreement ICS-FY-99-52 for Services to Develop and Implement a Replacement Land Court and  
(Insert Agreement Number or other Identifying Information)

Regular Automated Tracking System for the State of Hawaii

dated January 18, ~~XX~~ 2000 which was amended by Supplemental Agreement

No(s). \_\_\_\_\_, dated \_\_\_\_\_ (hereinafter collectively

referred to as "Agreement") whereby the CONTRACTOR agreed to provide the goods and services described in the Agreement, and

B. WHEREAS, the parties now desire to amend the Agreement.

NOW, THEREFORE, the STATE, and the CONTRACTOR mutually agree

to amend the Agreement as follows:

(CHECK APPLICABLE BOX(ES))

- Amend the SCOPE OF SERVICES according to the terms set forth in Attachment S1, which is attached hereto and is incorporated herein.
- Amend the TIME OF PERFORMANCE according to the terms set forth in Attachment S2, which is attached hereto and is incorporated herein.
- Amend the COMPENSATION AND PAYMENT SCHEDULE according to the terms set forth in Attachment S3, which is attached hereto and is incorporated herein.
- Amend the SPECIAL CONDITIONS according to the terms set forth in the Supplemental Special Conditions, which is attached hereto and incorporated herein.
- Recognize the CONTRACTOR's change of name.

FROM:

\_\_\_\_\_  
\_\_\_\_\_  
\_\_\_\_\_

TO:

\_\_\_\_\_  
\_\_\_\_\_  
\_\_\_\_\_

As set forth in the documents attached hereto as Exhibit \_\_\_\_\_, and incorporated herein.

A tax clearance certificate from the State of Hawaii  is  is not required to be submitted to the STATE prior to commencing any performance under this Supplemental Agreement.

A tax clearance certificate from the Internal Revenue Service  is  is not required to be submitted to the STATE prior to commencing any performance under this Supplemental Agreement.

Unless amended herein, the Agreement shall remain in full force and effect.

IN VIEW OF THE ABOVE, the STATE and the CONTRACTOR execute this Supplemental Agreement No. 1 by their signatures on the dates below.

STATE:

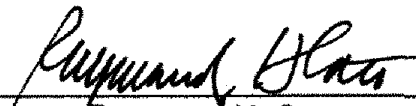
By   
Print Name Raymond H. Sato  
Title Comptroller  
Date 12/21/00

FUNDING AGENCY: (to be signed by head of funding agency if other than the Contracting Agency)

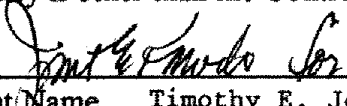
By   
Print Name Timothy E. Johns  
Title Chair, Dept. of Land & Natural Resources  
Date \_\_\_\_\_

(Affix Corporate Seal)

CONTRACTOR:

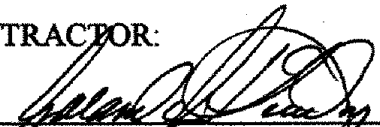
By   
Print Name Yolanda H. Lindsey  
Title President \*  
Date November 20, 2000

\*Evidence of authority of the Contractor's representative to sign this Supplemental Agreement must be attached.

APPROVED AS TO FORM:

  
Deputy Attorney General

500686

AG-Supp (4/99)



CONTRACTOR'S ACKNOWLEDGMENT

State of HAWAII)  
CITY & County of HONOLULU)

SS.

On this 20th day of NOVEMBER 19 2000 before me personally appeared YOLANDA H. LINDSEY, to me personally known, who being by me duly sworn, did say that he/she is the --- PRESIDENT --- of --- UNIQUE COMPUTER SYSTEMS, INC. dba THE LANGE GROUP ---, the CONTRACTOR named in the foregoing instrument, and that he/she is authorized to sign said instrument on behalf of the CONTRACTOR, and acknowledges that he/she executed said instrument as the free act and deed of the CONTRACTOR.

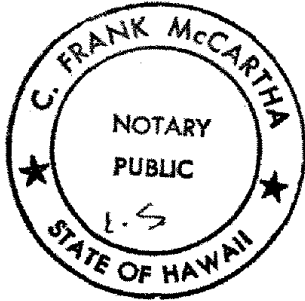

C. Frank McCarthy  
Notary Public, State of Hawaii  
My Commission Expires: 4/10/2007

500687

## STANDARDS OF CONDUCT DECLARATION

500688

For the purposes of this declaration:

"Agency" means and includes the State, the legislature and its committees, all executive departments, boards, commissions, committees, bureaus, offices, the University of Hawaii, and all independent commissions and other establishments of the state government but excluding the courts.

"Controlling interest" means an interest in a business or other undertaking which is sufficient in fact to control, whether the interest is greater or less than fifty per cent (50%).

"Employee" means any nominated, appointed, or elected officer or employee of the State, including members of boards, commissions, and committees, and employees under contract to the State or of the constitutional convention, but excluding legislators, delegates to the constitutional convention, justices, and judges.

UNIQUE COMPUTER SYSTEMS, INC.

On behalf of dba THE LANGE GROUP, CONTRACTOR, the undersigned does declare as follows:

1. CONTRACTOR  is  is not a legislator or an employee or a business in which a legislator or an employee has a controlling interest.\*
2. CONTRACTOR has not been assisted or represented by a legislator or employee for a fee or other compensation to obtain this Supplemental Agreement and will not be assisted or represented by a legislator or employee for a fee or other compensation in the performance of the Supplemental Agreement, if the legislator or employee had been involved in the development or award of the Supplemental Agreement.
3. CONTRACTOR has not been assisted or represented for a fee or other compensation in the award of this Supplemental Agreement by an Agency employee or, in the case of the Legislature, by a legislator.
4. CONTRACTOR has not been represented or assisted personally on matters related to the Supplemental Agreement by a person who has been an employee of the Agency within the preceding two (2) years and who participated while in state office or employment on the matter with which the Supplemental Agreement is directly concerned.
5. CONTRACTOR has not been represented or assisted on matters related to this Supplemental Agreement, for a fee or other consideration by an individual who, within the past twelve (12) months, has been an Agency employee, or in the case of the Legislature, a legislator.
6. CONTRACTOR has not been represented or assisted in the award of this Supplemental Agreement for a fee or other consideration by an individual who, a) within

the past twelve (12) months, served as an Agency employee or in the case of the Legislature, a legislator, and b) participated while an employee or legislator on matters related to this Supplemental Agreement.

CONTRACTOR understands that the Supplemental Agreement to which this document is attached is voidable on behalf of the STATE if this Supplemental Agreement was entered into in violation of any provision of chapter 84, HRS, commonly referred to as the Code of Ethics, including the provisions which are the source of the declarations above. Additionally, any fee, compensation, gift, or profit received by any person as a result of a violation of the Code of Ethics may be recovered by the STATE.

DATED: NOVEMBER 20, Hawaii, 19 2000.

CONTRACTOR

By 

Title PRESIDENT

\*Reminder to Agency: If "a" is checked, the Agency is required, under section 84-15, HRS, to file with the State Ethics Commission, ten (10) days before the Supplemental Agreement is entered into, a written justification as to why the Supplemental Agreement was not required to be competitively bid.

500689

**CERTIFICATION OF EXEMPTION FROM CIVIL SERVICE**

1. By Heads of State Departments or Agencies Pursuant to Delegation of the Director of Human Resources Development

Pursuant to the delegation of the authority by the Director of Human Resources Development, I certify that the services provided under this Agreement, and the person(s) providing the services under this Agreement are exempt from the civil service, pursuant to Hawaii Revised Statutes §76-16.

*Raymond H. Sato*  
(signature)

12/21/08  
(date)

Raymond H. Sato  
Print Name

Comptroller  
Print Title

2. By the Director of Human Resources Development, State of Hawaii

I certify that the services provided under this Agreement, and the person(s) providing the services under this Agreement are exempt from the civil service, pursuant to Hawaii Revised Statutes §76-16.

\_\_\_\_\_  
(signature)

\_\_\_\_\_  
(date)

\_\_\_\_\_  
Print Name

\_\_\_\_\_  
Print Title, if designee of Director  
of Human Resources Development

This part of the form may be used by all department heads and others to whom the Director of Human Resources Development has delegated authority to certify Hawaii Revised Statutes section 76-16 civil service exceptions. The specific paragraph(s) of section 76-16 upon which an exemption is based should be noted in the contract file. NOTE: Authority to certify exceptions under Hawaii Revised Statutes sections 76-16(2) and 76-16(3) has not been delegated; only the Director of Human Resources Development may certify sections 76-16(2) and 76-16(3) exceptions.

This part of the form may be used only by the Director of Human Resources Development or the Director's designee. See NOTE at footnote 1.

500690

**SCOPE OF SERVICES**

Pursuant to the Request For Proposals, section 3.10 Implementation Plan, the Contractor's work is to be performed by distinct tasks. The Contractor's Best and Final Offer dated November 15, 1999 and Contractor's clarification letters (hereinafter "Clarification Letters"), dated December 14, 1999 and December 23, 1999, attached hereto, and by this reference made a part hereof, further clarify the work to be completed. Contractor's scope of work by tasks is amended as follows:

- Part 1:
  - Task 1 Implement Basic BOC Network
  - Task 2 BCIS Requirements Verification
  - Task 3 Replace Reg & Land Court System
  - Task 4 Implement Imaging on BOC Network
  - Task 5 Implement Imaging BCIS
  
- Part 2:
  - Task 3 services
  - Task 6 Enable Remote Access to Data
  - Task 7 Enable Remote Access to Image
  - Task 10 Data Remediation
  
- Part 3:
  - Task 3 services
  - Task 8 Enable Public Access
  - Task 9 Public Access to Image
  - Task 11 GIS Requirements Study
  
- Part 4: Support Services

**TIME OF PERFORMANCE**

Pursuant to the Request For Proposals, Special Provisions, TERM OF CONTRACT, the Agreement is extended to September 21, 2001.

500692

## COMPENSATION AND PAYMENT SCHEDULE

The Payment Schedule as identified in the Original Contract is in error. The Clarification Letters were not reflected in the compensation amount; therefore, the compensation and payment schedule is amended as follows:

As compensation for the work to be performed by the Contractor, the State agrees to pay the Contractor as follows:

Part 1:	Task 1 Implement Basic BOC Network	\$240,782.21
	Task 2 BCIS Requirements Verification	48,458.02
	Task 3 Replace Reg & Land Court System	408,104.01
	Task 4 Implement Imaging on BOC Network	519,230.95
	Task 5 Implement Imaging BCIS	81,093.26
	<b>TOTAL PART 1:</b>	<b>\$1,297,668.45</b>
Part 2:	Task 3 services	\$ 67,812.06
	Task 6 Enable Remote Access to Data	77,393.92
	Task 7 Enable Remote Access to Image	47,167.44
	Task 10 Data Remediation	21,666.53
	<b>TOTAL PART 2:</b>	<b>\$214,039.95</b>
Part 3:	Task 3 services	\$ 27,603.99
	Task 8 Enable Public Access	139,472.55
	Task 9 Public Access to Image	62,027.76
	Task 11 GIS Requirements Study	33,749.78
	<b>TOTAL PART 3:</b>	<b>\$262,854.08</b>
Part 4:	Support Services	\$146,818.88

The Original Contract dated January 18, 1999 contracted for the services identified in Part 1 at a cost of ONE MILLION TWO HUNDRED NINETY-SVEN THOUSAND SIX HUNDRED SIXTY-EIGHT AND 45/100 DOLLARS (\$1,297,668.45).

For Supplemental Agreement No. 1, the State agrees to pay the Contractor an amount not to exceed TWO HUNDRED FOURTEEN THIRTY-NINE AND 95/100 DOLLARS (\$214,039.95), for Part 2.

Payments for the remainder of the work shall be paid at the rate specified herein, contingent upon availability of funds and by execution of a Supplemental Agreement(s) to this contract. In the event that funds are not appropriated and allotted, this Agreement will terminate with no further liability or obligation to the Contractor by the State.

500693

# The Lange Group

Software Systems Analysis & Telecommunications Consulting

December 14, 1999

Carl Watanabe, Deputy Registrar  
Bureau of Conveyances  
Department of Land and Natural Resources  
1151 Punchbowl Street, Room 122  
Honolulu, HI 96813

Re: ICS-FY-99-52 Task Milestones & Other Clarifications

Dear Mr. Watanabe,

In reference to the above captioned matter, and to follow-up after our initial discussions of December 8, 1999, we understand that the initial contract will cover only a portion of the Award, namely Task 1-5, 7 and 10 for a total of \$1,291,880.05. We understand that the balance of the Award will be contracted for completion in the year 2000, with the exception of Task 11, GIS Requirements Study, which may extend into year 2001. Because prices and availability of the "commodity" items listed in Attachment H change quite rapidly, and not within our control, we agree that where possible, the BOC should try to purchase these items directly from suppliers to obtain the greatest value.

We would like to clarify and provide the following items for your consideration:

1. Payment Milestones Schedule (see Attachment "A") – represents the cost by task along with the anticipated payment milestone schedule reflecting the deliverable item and estimated delivery date. Our detailed project schedule will be provided in Task 2 after notice to proceed.
2. Liquidated Damages – we would like to request that the per day amount be \$100.00. This amount would provide for allowances, other than change orders, should flexibility in the deliverable schedule be justified. This amount has been found in other State of Hawaii contracts. A higher amount would require a re-evaluation of the risk factors, which would take time and could increase our total cost.
3. APPX Software, Inc. Addendum – Attachment "B" is the APPX Subcontract Addendum which needs to be signed by a responsible party. It is required for installation and has been executed by other State of Hawaii agencies where SPEED II and APPX are used. It allows for defect-related warranties and states terms of use.

500694



Mr. Carl Watanabe  
December 14, 1999  
Page 2

4. Vendor Purchases of Attachment H products -- as per our discussion, we agree that the BOC should purchase directly from third party vendors where possible. We would like to request that on the "Notice To Proceed", a proviso be included to instruct us to do this, including purchasing of the critical IBM hardware and software products directly from IBM. This will insure the higher level of discounts to the BOC and eliminate any middleman fee markups. In this case, the BOC would issue a P.O directly to these vendors including IBM, for those "commodity" products. Also, any additional hardware needed at this time for Task 12 (PART 2), which we declined to bid on, can be purchased.
  
5. Task 7b, Backfile Microfilm Integration - we will work together with the BOC and the successful PART 2, Task 12 Microfilm Conversion (10 years backfile) vendor, to insure that the index data and images can be imported correctly, by providing the import software program(s) and training needed to perform the import reliably. The transfer of the raw data to the BCIS, and the actual importing of the data and images, is not provided for, and is up to the BOC to perform. Based on our initial discussion, suggested hardware configuration, software and installation cost alternatives will be provided to the BOC, for Task 12 budgetary purposes. More information is needed before purchases are made.

I speak for our entire team when I say that we are very pleased to have the honor of your favor in awarding this contract. We are proud to have gained your confidence. It remains my duty and I will insure that the BOC is well served. We are all looking forward to this new and exciting project. Should there be any questions, please do not hesitate to call me at 545-1822.

Happy Holidays!

Sincerely,

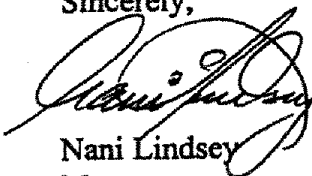

Nani Lindsey  
Manager

Attachments

500695

PAYMENT MILESTONE SCHEDULE Award: ICS-FY-99-52 Contract #1 (Task 1-5, 7, 10) Start Date: 2/1/00 Est Compl: 9/30/00		Labor + GET Incl. Sub Contractors	Attachment H	Total	% of Total	Est. Compl. Date
<b>Task 1 Implement a Basic BOC Network</b>						
Deliver Network Design Document	23,051.93		23,051.93	10%	2/15/00	
Delivery of Attachment H Components		135,315.18	135,315.18	56%	3/15/00	
Installation of Cabling (Boss Electric)	40,837.24		40,837.24	17%	3/15/00	
Installation of Hardware	41,577.86		41,577.86	17%	4/15/00	
Task 1 Totals	105,467.03	135,315.18	240,782.21	100%		
<b>Task 2 BCIS Requirements Verification</b>						
Deliver Requirements Document	48,458.02		48,458.02	100%	2/29/00	
Task 2 Totals:	48,458.02		48,458.02	100%		
<b>Task 3 Replacement of R/S &amp; L/C</b>						
Delivery of Attachment H Components		190,171.04	190,171.04	52%	3/31/00	
Installation of Hardware	38,339.34		38,339.34	10%	5/30/00	
Migration Prototype Test (Wang Replacement)	43,541.39		43,541.39	12%	5/30/00	
Migration Acceptance Test (Production)	21,979.02		21,979.02	6%	7/30/00	
New R/S and GI's Completion	45,833.04		45,833.04	12%	9/30/00	
New Enhancements Completion	27,603.99		27,603.99	8%	11/30/00	
Task 3 Totals:	177,296.78	190,171.04	367,467.82	100%		
<b>Task 4 Imaging on BOC</b>						
System Requirements Document	44,458.06		44,458.06	9%	4/30/00	
Delivery of Attachment H Components		251,048.26	251,048.26	52%	4/30/00	
Installation of Imaging Hardware	38,299.79		38,299.79	8%	5/30/00	
Installation of Imaging Software	70,653.73		70,653.73	15%	6/30/00	
Completion of Training	80,784.93		80,784.93	17%	6/30/00	
Task 4 Totals:	234,196.51	251,048.26	485,244.77	100%		
<b>Task 5 Imaging on BCIS</b>						
Completion of Acceptance Test (Production)	44,739.33		44,739.33	55%	7/30/00	
Completion of Training	36,353.93		36,353.93	45%	7/30/00	
Task 5 Totals:	81,093.26		81,093.26	100%		
<b>Task 7 Enable Access to Images</b>						
(7b) Deliver Requirements Document	17,945.73		17,945.73	38%	8/31/00	
(7b) Completion of Programs & Training	14,449.91		14,449.91	31%	8/31/00	
(7) Completion of Programs & Training	14,771.80		14,771.80	31%	10/31/00	
Task 7 Totals:	47,167.44		47,167.44	100%		
<b>Task 10 Data Remediation</b>						
Deliver Requirements Document	3,999.97		3,999.97	18%	8/15/00	
Completion Programs & Training (TG Indexes)	10,583.27		10,583.27	49%	9/30/00	
Mainframe Import of 1976-1990 (BOC Indexes)	7,083.29		7,083.29	33%	9/30/00	
Task 10 Totals:	21,666.53		21,666.53	100%		
<b>Contract #1 Grand Totals:</b>	<b>715,345.57</b>	<b>576,534.48</b>	<b>1,291,880.05</b>			

500696

Carl

# The Lange Group

Software Systems Analysis & Telecommunications Consulting

December 23, 1999

Carl Watanabe, Deputy Registrar  
Bureau of Conveyances  
Department of Land and Natural Resources  
1151 Punchbowl Street, Room 122  
Honolulu, HI 96813

Re: ICS-FY-99-52 Task 12 Additional Hardware Requirements

Dear Mr. Watanabe,

In reference to the above captioned matter, and to follow up after our discussions of December 22, 1999 regarding the additional hardware required for Task 12 – Microfilm Conversion, please find attached the following:

1. Revised Attachment H Task 3 and Task 4 three (3) pages – reflecting additional hardware needed for Task 12
2. Two revised IBM Configuration – the first configuration shows the two (2) node (primary and redundant node), and the second configuration shows the rest of the items including the increased disk (DASD) and upgraded 3995-C68 fully loaded optical juke box. Both configurations show List Price and do not reflect the BOC discount. It is intended to itemize the hardware parts needed for your review only.

The first IBM Configuration, second page under “Hardware Mes/Upgrades” includes both the primary and secondary nodes and must be divided in half to get the Primary and optional Redundant node list prices for both the hardware and maintenance.

The second IBM Configuration, shows a fully loaded Optical Library, along with the added Disk Subsystem rack which includes thirty-two (32) 36.4GB drives to contain the 5 year backfile mirrored on-line disk, for an additional 1.1648 TB. The other 7133-D40 SSA Disk Subsystem is from our original configuration with sixteen (16) 9.1GB drives. This fills up three of the four drawers available in the system disk rack (16 drives per drawer). The Optical Library was upgraded from a model C66 to a C68, and fully loaded with five (5) 52 drive packs (5.2GB per drive), for a total of 1.352TB.

500697

Mr. Carl Watanabe  
December 23, 1999  
Page 2

We envision these items to be installed during Task 3 and Task 4. The estimated hardware cost if purchased directly from IBM, including the 4.166% general excise tax is shown in the Revised Attachment H. The net increase in hardware cost expended during Task 3 is ~~\$132,305.37~~ and 136,052.27 the net increase in hardware cost expended during Task 4 is \$33,986.18. This represents an total hardware cost of \$166,291.55 allocated to Task 12.

I hope the above provides the needed information to plan for Task 12. Please do not hesitate to call me should there be any other questions at 545-1822.

Sincerely,



Nani Lindsey  
Manager

enclosures

500698

**Phase 1 Task 3: Hardware & Software Prices for Replacement of the Regular and Land Court Systems (RS/6000 9076 SP)**

Description	Unit Price	Qty	Extended
<b>Hardware</b>			
<i>RS/6000 9076 SP Enterprise Server Node</i>			
RS/6000 9076 SP Enterprise Server Node (2051)	\$56,450.26	1	\$56,450.26
7133-D40 SSA Disk Subsystem (Rack-Mounted - (1) drawer of 16 - 9.1GB drives)	37,212.26	1	37,212.26
7014-S00 rack & 7133-D40 SSA Disk Subsystem (Rack-Mounted - (2) drawers each with 16 - 36.4GB drives)	139,799.10	1	139,799.10
<b>Total RS/6000 9076 SP Enterprise Server Hardware</b>			<b>\$233,461.62</b>
<i>RS/6000 9076 SP Redundant Server Node Hardware</i> <b>**OPTIONAL**</b>			
RS/6000 9076 SP Enterprise Server Node (2051)	\$56,450.26	1	\$56,450.26
7133-D40 SSA Disk Subsystem (Rack-Mounted - (1) drawer of 16 - 9.1GB drives)	37,212.26	1	37,212.26
<b>Total RS/6000 9076 SP Optional Redundant Node Hardware</b>	<b>**OPTIONAL**</b>		<b>\$93,662.52</b>
<i>RS/6000 9076 SP BOC Enterprise Server Software</i>			
5765-C64 IBM C for AIX V4.4 - FC 0001 Basic One-time charge	499.37	1	499.37
5692-AIX System Software - FC 1004 CD-ROM Process Charge	52.08	1	52.08
<b>Total RS/6000 9076 SP Enterprise Server Software</b>			<b>\$551.45</b>
<i>RS/6000 9076 SP BOC Redundant Node Software</i> <b>**OPTIONAL**</b>			
5765-C34 AIX Version 4	\$ N/C	1	\$ N/C
5765-C34 FC 4061 AIX 4.3 for (1-2) users	N/C	1	N/C
5765-C34 FC 5005 Preinstall	N/C	1	N/C
5765-C34 FC 9001 Asset Registration	N/C	1	N/C
5692-AIX System Software - FC 1004 CD-ROM Process Charge	52.08	1	52.08
<b>Total RS/6000 9076 SP Optional Redundant Node Software</b>	<b>**OPTIONAL**</b>		<b>\$52.08</b>
<i>DB2 UDB Enterprise Edition includes 2 year Subscription &amp; Support</i>			
DB2 UDB Enterprise Edition V 6.1- D37BFML	6,249.96	4	24,999.84
DB2 UDB Media & Documentation - BB6X4NA, BB6VWML	93.75	1	93.75
DB2 UDB Developer Edition - D0096ML	932.29	2	1,864.58
<b>Total DB2 Software</b>			<b>\$26,958.17</b>
<i>DB2 UDB Enterprise Edition includes 2 year Subscription &amp; Support for Optional Redundant RS/6000 9076 SP Server - NODE USED IN STANDBY CAPACITY ONLY</i>			
<b>Total DB2 Software for Optional Redundant Server</b>	<b>**OPTIONAL**</b>		<b>NC</b>

93,662.52

Optional

Optional

Description	Unit Price	Qty	Extended
<b>Phase 1 Task 3 (Continued)</b>			
<i><b>APPX Software License</b></i>			
APPX Software license for 50 users, 2 developers w/DB2 interface, including 1 <sup>st</sup> year software subscription	\$59,775.00	1	\$59,775.00
<i><b>Barcode Label Printers</b></i>			
Zebra Desktop T402 Bar Code Thermal Transfer Ptr. & Cables	\$912.84	6	\$5,477.04
<b>Phase 1 Task 3 Price Summary</b>			
Required Hardware and Software			\$326,223.28
Optional Hardware and Software	**OPTIONAL**		93,714.60
<b>Total Phase 1 Task 3 Required and Optional Hardware &amp; Software</b>			\$419,937.87

500700

**Phase 2 Task 4: Hardware & Software Prices for  
Implementing Imaging Capability on the BOC Network  
(Optical Jukebox, Scanners, & Microfilm Writer)**

Description	Unit Price	Qty	Extended
<b>Hardware</b>			
<i>Optical Library (Jukebox for BOC Enterprise Server)</i>			
IBM 3995 Optical Library Model C68 with 260 (5.2GB) optical platters for BOC Enterprise Server node (provides 1,352GB capacity)	\$82,613.33	1	\$82,613.33
<b>Total Optical Library (Jukebox for BOC Enterprise Server)</b>			\$82,613.33
<b>Hardware</b>			
<i>Image Scanners</i>			
Kodak Digital Science Scanner 3500D, Duplex - 840-4378	\$19,952.26	2	\$39,904.52
1700s Adrenaline IP Accelerator, 12MB SCSI Full PCI EH-1700-1000	2,702.18	2	5,404.36
Kofax 3500D Scan Cable SC-1024-0000	233.45	2	466.90
Vidar TruScan Select 38" wide Scanner (41" throat) 400dpi 1/2"-1"/sec Adaptive Area Thresholding, install & training -11653	\$10,984.00	1	\$10,984.00
SCSI Card Adapter	260.41	1	260.41
<b>Total Image Scanner Hardware</b>			<b>\$57,020.19</b>
<i>Microfilm Writer</i>			
Kodak Digital Science Archive Writer 4800 including installation (1 year warranty) 870-9248	\$35,567.35	1	\$35,567.35
Digital Science Archive Writer Cassette 66 868-4383	753.75	1	753.75
Digital Science Archive Writer 4800 Training 883-4350	175.00	1	175.00
Digital Science Archive Writer Interface Software 123-9557	4,292.16	1	4,292.16
Kodak Digital Science Document Archive Writer 4800 Pre-installation site accreditation 877-1495	1,022.79	1	1,022.79
<b>Total Microfilm Hardware</b>			<b>\$41,811.05</b>
<b>Software</b>			
<i>Scan and Index Capture software</i>			
Kofax Ascent Capture - Scan 200k per month	\$7,909.09	2	\$15,818.18
Kofax Ascent Capture - Workstation (1 pak)	2,512.48	1	2,512.48
Kofax Ascent Capture - Workstation (3 pak)	7,223.39	1	7,223.39
<b>Total Scan and Index Capture Software</b>			<b>\$25,554.05</b>
<i>Long Term Storage and Retrieval Software includes 2 years subscription with support</i>			
IBM VisualInfo Program Kit for server - D00KBML	\$17,499.89	1	\$17,499.89
IBM VisualInfo Concurrent User - D05T2ML	1,728.11	35	60,483.85
IBM VisualInfo Media Kit - 39L3902	52.08	1	52.08
<b>Total Long Term Storage and Retrieval Software</b>			<b>\$78,035.82</b>
<b>Total Phase 2 Task 4 Imaging Hardware &amp; Software Price</b>			<b>\$285,034.44</b>

500701

STATE OF HAWAII  
SUPPLEMENTAL AGREEMENT NO. 2  
TO AGREEMENT ICS-FY-99-52

(Insert Agreement Number or Other Identifying Information)

This Supplemental Agreement No. 2, executed on the respective dates indicated below, is effective as of June 1, 2001, between the \_\_\_\_\_

Department of Accounting and General Services, State of Hawaii  
(Insert Name of State Department, Agency, Board or Commission)

(hereinafter "STATE"), by its Comptroller  
(Insert Title of State Officer Executing Agreement)

whose address is 1151 Punchbowl Street, Honolulu, Hawaii 96813

\_\_\_\_\_, and  
Unique Computer Systems, Inc. dba The Lange Group (hereinafter "CONTRACTOR"),

a corporation  
(Insert "Corporation", "Partnership", "Joint Venture", "Sole Proprietorship", or other legal form of the Contractor)

under the laws of the State of Hawaii, whose business address and taxpayer

identification number are as follows: 1100 Ward Avenue, Suite 1050, Honolulu, Hawaii

96814; Taxpayer id: 1019306

RECITALS

A. WHEREAS, the STATE and the CONTRACTOR entered into an Agreement ICS-FY-99-52 for Services to Develop and Implement a Replacement Land Court and  
(Insert Agreement Number or other Identifying Information)  
Regular Automated Tracking System for the State of Hawaii

dated January 18, ~~XX~~92000, which was amended by Supplemental Agreement

No(s). 1, dated June 29, 2000 (hereinafter collectively

referred to as "Agreement") whereby the CONTRACTOR agreed to provide the goods and services described in the Agreement, and

B. WHEREAS, the parties now desire to amend the Agreement.



NOW, THEREFORE, the STATE, and the CONTRACTOR mutually agree

to amend the Agreement as follows:

(CHECK APPLICABLE BOX(ES))

- Amend the SCOPE OF SERVICES according to the terms set forth in Attachment S1, which is attached hereto and is incorporated herein.
- Amend the TIME OF PERFORMANCE according to the terms set forth in Attachment S2, which is attached hereto and is incorporated herein.
- Amend the COMPENSATION AND PAYMENT SCHEDULE according to the terms set forth in Attachment S3, which is attached hereto and is incorporated herein.
- Amend the SPECIAL CONDITIONS according to the terms set forth in the Supplemental Special Conditions, which is attached hereto and incorporated herein.
- Recognize the CONTRACTOR's change of name.

FROM:

\_\_\_\_\_  
\_\_\_\_\_  
\_\_\_\_\_

TO:

\_\_\_\_\_  
\_\_\_\_\_  
\_\_\_\_\_

As set forth in the documents attached hereto as Exhibit \_\_\_\_\_, and incorporated herein.

A tax clearance certificate from the State of Hawaii  is  is not required to be submitted to the STATE prior to commencing any performance under this Supplemental Agreement.

A tax clearance certificate from the Internal Revenue Service  is  is not required to be submitted to the STATE prior to commencing any performance under this Supplemental Agreement.

Unless amended herein, the Agreement shall remain in full force and effect.

IN VIEW OF THE ABOVE, the STATE and the CONTRACTOR execute this Supplemental Agreement No. 2 by their signatures on the dates below.

STATE:

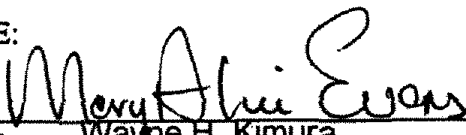
By   
Print Name Wayne H. Kimura  
Title Comptroller  
Date JUN 18 2001

FUNDING AGENCY: (to be signed by head of funding agency if other than the Contracting Agency)

By   
Print Name Carl T. Watanabe  
Title Acting Registrar  
Date June 7, 2001

CONTRACTOR:

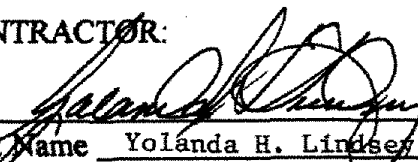
By   
Print Name Yolanda H. Lindsey  
Title President \*  
Date June 7, 2001

\*Evidence of authority of the Contractor's representative to sign this Supplemental Agreement must be attached.

APPROVED AS TO FORM:

  
Deputy Attorney General

500704

CONTRACTOR'S ACKNOWLEDGMENT

State of HAWAII )  
 )  
CITY & County of HONOLULU )

SS.

On this 7th day of JUNE, 20 01, before me personally  
appeared YOLANDA H. LINDSEY, to me personally known, who being by me  
duly sworn, did say that ~~he~~she is the --- PRESIDENT --- of  
--- UNIQUE COMPUTER SYSTEMS, INC. dba THE LANGE GROUP ---, the  
CONTRACTOR named in the foregoing instrument, and that he/she is authorized to sign said  
instrument on behalf of the CONTRACTOR, and acknowledges that he/she executed said instrument  
as the free act and deed of the CONTRACTOR.

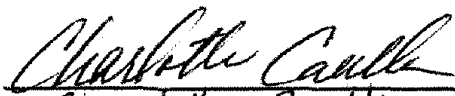
  
Charlotte Caulk

(Print Name)

Notary Public, State of HAWAII  
My Commission Expires: 12/17/2004

LS

## STANDARDS OF CONDUCT DECLARATION

For the purposes of this declaration:

"Agency" means and includes the State, the legislature and its committees, all executive departments, boards, commissions, committees, bureaus, offices, the University of Hawaii, and all independent commissions and other establishments of the state government but excluding the courts.

"Controlling interest" means an interest in a business or other undertaking which is sufficient in fact to control, whether the interest is greater or less than fifty per cent (50%).

"Employee" means any nominated, appointed, or elected officer or employee of the State, including members of boards, commissions, and committees, and employees under contract to the State or of the constitutional convention, but excluding legislators, delegates to the constitutional convention, justices, and judges.

On behalf of UNIQUE COMPUTER SYSTEMS, INC.  
dba THE LANGE GROUP, CONTRACTOR, the undersigned does declare as follows:

1. CONTRACTOR /is/ (is not) a legislator or an employee or a business in which a legislator or an employee has a controlling interest. \*

2. CONTRACTOR has not been assisted or represented by a legislator or employee for a fee or other compensation to obtain this Agreement and will not be assisted or represented by a legislator or employee for a fee or other compensation in the performance of the Agreement, if the legislator or employee had been involved in the development or award of the Agreement.

3. CONTRACTOR has not been assisted or represented for a fee or other compensation in the award of this Agreement by an Agency employee or, in the case of the Legislature, by a legislator.

4. CONTRACTOR has not been represented or assisted personally on matters related to the Agreement by a person who has been an employee of the Agency within the preceding two (2) years and who participated while in state office or employment on the matter with which the Agreement is directly concerned.

5. CONTRACTOR has not been represented or assisted on matters related to this Agreement, for a fee or other consideration by an individual who, within the past twelve (12) months, has been an Agency employee, or in the case of the Legislature, a legislator.

6. CONTRACTOR has not been represented or assisted in the award of this Agreement for a fee or other consideration by an individual who, a) within the past twelve (12) months, served as an Agency employee or in the case of the Legislature, a legislator, and b) participated while an employee or legislator on matters related to this Agreement.

CONTRACTOR understands that the Agreement to which this document is attached is voidable on behalf of the STATE if this Agreement was entered into in violation of any provision of chapter 84, HRS, commonly referred to as the Code of Ethics, including the provisions which are the source of the declarations above. Additionally, any fee, compensation, gift, or profit received by any person as a result of a violation of the Code of Ethics may be recovered by the STATE.

DATED: Honolulu, Hawaii, JUNE 7, 2001

**CONTRACTOR**

UNIQUE COMPUTER SYSTEMS, INC.  
dba THE LANGE GROUP

*(Insert name of Contractor)*

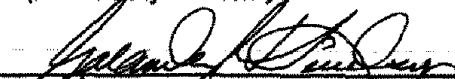
By   
Print Name YOLANDA H. LINDSEY  
Title PRESIDENT

\*Reminder to Agency: If "is" is circled, the Agency is required, under section 84-15, HRS, to file with the State Ethics Commission, ten (10) days before the Agreement is entered into, a written justification as to why the Agreement was not required to be competitively bid.

**CERTIFICATION OF EXEMPTION FROM CIVIL SERVICE**

**1. By Heads of State Departments or Agencies Pursuant to Delegation of the Director of Human Resources Development<sup>1</sup>**

Pursuant to the delegation of the authority by the Director of Human Resources Development, I certify that the services provided under this Agreement, and the person(s) providing the services under this Agreement are exempt from the civil service, pursuant to Hawaii Revised Statutes § 76-16.

Mary Alvin Evans

JUN 18 2001

Signature

Date

for Wayne H. Kimura  
Print Name

Comptroller  
Print Title

**2. By the Director of Human Resources Development, State of Hawaii<sup>2</sup>**

I certify that the services provided under this Agreement, and the person(s) providing the services under this Agreement are exempt from the civil service, pursuant to Hawaii Revised Statutes §76-16(\_\_\_\_).

\_\_\_\_\_  
Signature

\_\_\_\_\_  
Date

\_\_\_\_\_  
Print Name

\_\_\_\_\_  
Print Title, if designee of Director of Human Resources Development

<sup>1</sup>This part of the form may be used by all department heads and others to whom the Director of Human Resources Development has delegated authority to certify Hawaii Revised Statutes section 76-16 civil services exceptions. The specific paragraph(s) of section 76-16 upon which an exemption is based should be noted in the contract file. NOTE: Authority to certify exceptions under Hawaii Revised Statutes section 76-16(2) and 76-16(3) has not been delegated; only the Director of Human Resources Development may certify sections 76-16(2) and 76-16(3) exceptions.

<sup>2</sup>This part of the form may be used only by the Director of Human Resources Development or the Director's Designee. See NOTE at footnote 1.

**TIME OF PERFORMANCE**

Pursuant to the Request For Proposals, Special Provisions, TERM OF CONTRACT, the Agreement is extended to December 31, 2001.

500709

**COMPENSATION AND PAYMENT SCHEDULE**

Pursuant to the COMPENSATION AND PAYMENT SCHEDULE of the Agreement (as described in Supplemental Agreement No. 1), the State agrees to pay the Contractor an amount not to exceed TWO HUNDRED SIXTY-TWO THOUSAND EIGHT HUNDRED FIFTY-FOUR AND 08/100 DOLLARS (\$262,854.08) for Part 3. Money is available to pay for Part 3 pursuant to Act 125, SLH 1999.

500710



# The Lange Group

Software Systems Analysis & Telecommunications Consulting

---

## CERTIFICATION OF CORPORATE RESOLUTION

I, Yolanda H. Lindsey, Secretary of Unique Computer Systems, Inc., a Hawaii corporation, do hereby certify that the following is a full, true and correct copy of a resolution duly adopted by the Board of Directors of said Corporation, at its meeting held on the nineteenth day of January 2001 at it's offices at 1100 Ward Avenue, Suite 1050, Honolulu, Hawaii 96814, at which a quorum was present, and acting throughout, and that said resolution has not been modified, amended or rescinded and continues in full force and effect:

"RESOLVED that any individual at the time of holding the position of President is hereby authorized to execute on behalf of the Corporation, any bid, proposal, contract, agreement, bonds, surety bonds, and other documents and instruments required by any such bid, proposal, or contract, for software and consulting services to be performed by the Corporation.

IN WITNESS WHEREOF, I have hereunto set my hand and affixed the corporate seal of Unique Computer Systems, Inc. dba The Lange Group, on this 7<sup>th</sup> day of June, 2001.

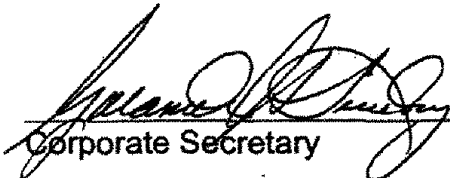
  
Corporate Secretary

(SEAL)

500711

ORIGINAL  
SIGNATURES

STATE OF HAWAII  
SUPPLEMENTAL AGREEMENT NO. 3  
TO AGREEMENT ICS-FY-99-52  
(Insert Agreement Number or Other Identifying Information)

For: Nani *nd*  
*1-9-02*  
*Cal*

This Supplemental Agreement No. 3, executed on the respective dates indicated below, is effective as of December 30, 2001, between the \_\_\_\_\_  
Department of Accounting and General Services, State of Hawaii  
(Insert Name of State Department, Agency, Board or Commission)  
(hereinafter "STATE"), by its Comptroller  
(Insert Title of State Officer Executing Agreement)  
whose address is 1151 Punchbowl Street, Honolulu, Hawaii 96813

\_\_\_\_\_, and  
Unique Computer Systems, Inc., dba The Lange Group (hereinafter "CONTRACTOR"),  
a corporation  
(Insert "Corporation", "Partnership", "Joint Venture", "Sole Proprietorship", or other legal form of the Contractor)  
under the laws of the State of Hawaii, whose business address and taxpayer identification number are as follows: 1100 Ward Avenue, Suite 1050, Honolulu, HI 96814;  
Taxpayer id: 1019306

**RECITALS**

A. WHEREAS, the STATE and the CONTRACTOR entered into an Agreement ICS-FY-99-52 for Services to Develop and Implement a Replacement Land Court and  
(Insert Agreement Number or other Identifying Information)  
Regular Automated Tracking System for the State of Hawaii  
dated January 18 ~~XX~~ 2000, which was amended by Supplemental Agreement No(s). 1, 2, dated June 29, 2000, June 1, 2001 (hereinafter collectively referred to as "Agreement") whereby the CONTRACTOR agreed to provide the goods and services described in the Agreement, and

B. WHEREAS, the parties now desire to amend the Agreement.

NOW, THEREFORE, the STATE, and the CONTRACTOR mutually agree

to amend the Agreement as follows:

(CHECK APPLICABLE BOX(ES))

- Amend the SCOPE OF SERVICES according to the terms set forth in Attachment S1, which is attached hereto and is incorporated herein.
- Amend the TIME OF PERFORMANCE according to the terms set forth in Attachment S2, which is attached hereto and is incorporated herein.
- Amend the COMPENSATION AND PAYMENT SCHEDULE according to the terms set forth in Attachment S3, which is attached hereto and is incorporated herein.
- Amend the SPECIAL CONDITIONS according to the terms set forth in the Supplemental Special Conditions, which is attached hereto and incorporated herein.
- Recognize the CONTRACTOR's change of name.

FROM:

\_\_\_\_\_  
\_\_\_\_\_

TO:

\_\_\_\_\_  
\_\_\_\_\_

As set forth in the documents attached hereto as Exhibit \_\_\_\_\_, and incorporated herein.

A tax clearance certificate from the State of Hawaii  is  is not required to be submitted to the STATE prior to commencing any performance under this Supplemental Agreement.

A tax clearance certificate from the Internal Revenue Service  is  is not required to be submitted to the STATE prior to commencing any performance under this Supplemental Agreement.

Unless amended herein, the Agreement shall remain in full force and effect.

IN VIEW OF THE ABOVE, the STATE and the CONTRACTOR execute this Supplemental Agreement No. 3 by their signatures on the dates below.

STATE:

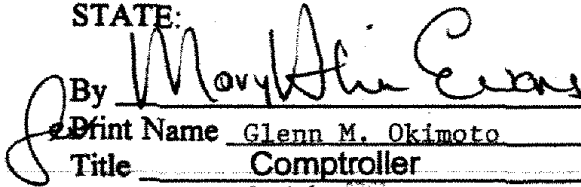
By   
Print Name Glenn M. Okimoto  
Title Comptroller  
Date DEC 31 2001

FUNDING AGENCY: (to be signed by head of funding agency if other than the Contracting Agency)

By \_\_\_\_\_  
Print Name \_\_\_\_\_  
Title \_\_\_\_\_  
Date \_\_\_\_\_

CONTRACTOR:

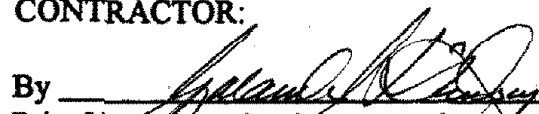
By  15  
Print Name Yolanda H. Lindsey  
Title President \*  
Date December 12, 2001

\*Evidence of authority of the Contractor's representative to sign this Supplemental Agreement must be attached.

APPROVED AS TO FORM:

  
Deputy Attorney General

CONTRACTOR'S ACKNOWLEDGMENT

State of HAWAII )  
 )  
CITY & County of HONOLULU )

SS.

On this 12th day of DECEMBER, 2001, before me personally  
appeared YOLANDA H. LINDSEY, to me personally known, who being by me  
duly sworn, did say that he/she is the --- PRESIDENT --- of  
--- UNIQUE COMPUTER SYSTEMS, INC. dba THE LANGE GROUP---, the

CONTRACTOR named in the foregoing instrument, and that he/she is authorized to sign said  
instrument on behalf of the CONTRACTOR, and acknowledges that he/she executed said instrument  
as the free act and deed of the CONTRACTOR.

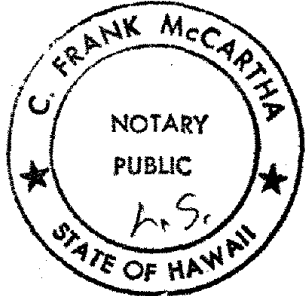

*C. Frank McCarthy*  
CFRANK MCCARTHA  
(Print Name)  
Notary Public, State of Hawaii  
My Commission Expires: 9/10/2004

## STANDARDS OF CONDUCT DECLARATION

For the purposes of this declaration:

"Agency" means and includes the State, the legislature and its committees, all executive departments, boards, commissions, committees, bureaus, offices, the University of Hawaii, and all independent commissions and other establishments of the state government but excluding the courts.

"Controlling interest" means an interest in a business or other undertaking which is sufficient in fact to control, whether the interest is greater or less than fifty per cent (50%).

"Employee" means any nominated, appointed, or elected officer or employee of the State, including members of boards, commissions, and committees, and employees under contract to the State or of the constitutional convention, but excluding legislators, delegates to the constitutional convention, justices, and judges.

Unique Computer Systems, Inc.  
On behalf of dba THE LANGE GROUP, CONTRACTOR, the undersigned does declare as follows:

1. CONTRACTOR ~~/is/~~ (is not) a legislator or an employee or a business in which a legislator or an employee has a controlling interest.\*
2. CONTRACTOR has not been assisted or represented by a legislator or employee for a fee or other compensation to obtain this Agreement and will not be assisted or represented by a legislator or employee for a fee or other compensation in the performance of the Agreement, if the legislator or employee had been involved in the development or award of the Agreement.
3. CONTRACTOR has not been assisted or represented for a fee or other compensation in the award of this Agreement by an Agency employee or, in the case of the Legislature, by a legislator.
4. CONTRACTOR has not been represented or assisted personally on matters related to the Agreement by a person who has been an employee of the Agency within the preceding two (2) years and who participated while in state office or employment on the matter with which the Agreement is directly concerned.
5. CONTRACTOR has not been represented or assisted on matters related to this Agreement, for a fee or other consideration by an individual who, within the past twelve (12) months, has been an Agency employee, or in the case of the Legislature, a legislator.
6. CONTRACTOR has not been represented or assisted in the award of this Agreement for a fee or other consideration by an individual who, a) within the past twelve (12) months, served as an Agency employee or in the case of the Legislature, a legislator, and b) participated while an employee or legislator on matters related to this Agreement.

CONTRACTOR understands that the Agreement to which this document is attached is voidable on behalf of the STATE if this Agreement was entered into in violation of any provision of chapter 84, HRS, commonly referred to as the Code of Ethics, including the provisions which are the source of the declarations above. Additionally, any fee, compensation, gift, or profit received by any person as a result of a violation of the Code of Ethics may be recovered by the STATE.

DATED: Honolulu, Hawaii, December 12, 2001

**CONTRACTOR**

Unique Computer Systems, Inc.  
dba THE LANGE GROUP

*(Insert name of Contractor)*

By   
Print Name Yolanda H. Lindsey  
Title President

\*Reminder to Agency: If "is" is circled, the Agency is required, under section 84-15, HRS, to file with the State Ethics Commission, ten (10) days before the Agreement is entered into, a written justification as to why the Agreement was not required to be competitively bid.

500717

**CERTIFICATION OF EXEMPTION FROM CIVIL SERVICE**

**1. By Heads of State Departments or Agencies Pursuant to Delegation of the Director of Human Resources Development<sup>1</sup>**

Pursuant to the delegation of the authority by the Director of Human Resources Development, I certify that the services provided under this Agreement, and the person(s) providing the services under this Agreement are exempt from the civil service, pursuant to Hawaii Revised Statutes § 76-16.

Mary Alice Ewens

12-31-81

Signature

Date

for Glenn M. Okimoto

Print Name

Comptroller

Print Title

**2. By the Director of Human Resources Development, State of Hawaii<sup>2</sup>**

I certify that the services provided under this Agreement, and the person(s) providing the services under this Agreement are exempt from the civil service, pursuant to Hawaii Revised Statutes §76-16( ).

\_\_\_\_\_  
Signature

\_\_\_\_\_  
Date

\_\_\_\_\_  
Print Name

\_\_\_\_\_  
Print Title, if designee of Director of  
Human Resources Development

500718

<sup>1</sup>This part of the form may be used by all department heads and others to whom the Director of Human Resources Development has delegated authority to certify Hawaii Revised Statutes section 76-16 civil services exceptions. The specific paragraph(s) of section 76-16 upon which an exemption is based should be noted in the contract file. NOTE: Authority to certify exceptions under Hawaii Revised Statutes section 76-16(2) and 76-16(3) has not been delegated; only the Director of Human Resources Development may certify sections 76-16(2) and 76-16(3) exceptions.

<sup>2</sup>This part of the form may be used only by the Director of Human Resources Development or the Director's Designee. See NOTE at footnote 1.



**TIME OF PERFORMANCE**

---

Pursuant to the Request for Proposals, Special Provisions, TERM OF CONTRACT, the Agreement is extended to June 30, 2002.

---

**500719**

# The Lange Group

Software Systems Analysis & Telecommunications Consulting

---

## CERTIFICATION OF CORPORATE RESOLUTION

I, Yolanda H. Lindsey, Secretary of Unique Computer Systems, Inc., a Hawaii corporation, do hereby certify that the following is a full, true and correct copy of a resolution duly adopted by the Board of Directors of said Corporation, at its meeting held on the nineteenth day of January 2001 at it's offices at 1100 Ward Avenue, Suite 1050, Honolulu, Hawaii 96814, at which a quorum was present, and acting throughout, and that said resolution has not been modified, amended or rescinded and continues in full force and effect:

"RESOLVED that any individual at the time of holding the position of President is hereby authorized to execute on behalf of the Corporation, any bid, proposal, contract, agreement, bonds, surety bonds, and other documents and instruments required by any such bid, proposal, or contract, for software and consulting services to be performed by the Corporation.

IN WITNESS WHEREOF, I have hereunto set my hand and affixed the corporate seal of Unique Computer Systems, Inc. dba The Lange Group, on this 12th day of December, 2001 .

  
Corporate Secretary

(SEAL)

500720

BENJAMIN J. CAYETANO  
GOVERNOR



**FILE**  
LENN M. OKIMOTO  
Comptroller  
MARY ALICE EVANS  
Deputy Comptroller

STATE OF HAWAII  
DEPARTMENT OF ACCOUNTING  
AND GENERAL SERVICES  
P.O. BOX 119  
HONOLULU, HAWAII 96810-0119

June 17, 2002

Ms. Nani Lindsey  
The Lange Group  
1100 Ward Avenue, Suite 1050  
Honolulu, HI 96814

Dear Ms. Lindsey:

Subject: ICS-FY-99-52 Supplemental Agreement No. 4  
For Services to Develop and Implement a Replacement Land Court and Regular  
Automated Tracking System for the State of Hawaii

Enclosed is a fully executed copy of Supplemental Agreement No. 4 for ICS-FY99-52 for your  
file.

If you have any questions on this matter, please call Ms. Barbara Tom, Planning and Project  
Management Officer, at (808) 586-1913.

Sincerely,

A handwritten signature in black ink, appearing to read "Lester M. Nakamura".

LESTER M. NAKAMURA, Administrator  
Information and Communication  
Services Division

Enclosure

500721

# The Lange Group

Software Systems Analysis & Telecommunications Consulting

---

## CERTIFICATION OF CORPORATE RESOLUTION

The undersigned, being the corporate secretary of Unique Computer Systems, Inc., dba The Lange Group, a Hawaii corporation, do hereby certify that the following is a full, true and correct copy of a resolution duly adopted by the Board of Directors of said Corporation, at a meeting duly called and held on the eighteenth day of January 2002 at it's offices at 1100 Ward Avenue, Suite 1050, Honolulu, Hawaii 96814, at which a quorum was present, and acting throughout, and that said resolution has not been modified, amended or rescinded and continues in full force and effect:

"RESOLVED that any individual at the time of holding the position of President of this corporation, is hereby authorized to execute on behalf of the Corporation, any bid, proposal, contract, agreement, bonds, surety bonds, and other documents and instruments required by any such bid, proposal, or contract, for software and consulting services to be performed by the Corporation with the State of Hawaii or any agency of department thereof.

IN WITNESS WHEREOF, I have hereunto set my hand and affixed the corporate seal of Unique Computer Systems, Inc. dba The Lange Group, on this 29th day of May, 2002.

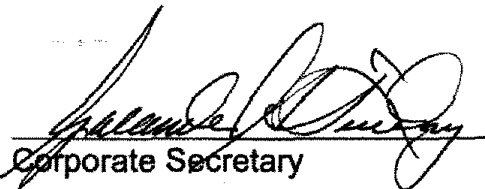
  
Corporate Secretary

(SEAL)

500722

STATE OF HAWAII  
SUPPLEMENTAL AGREEMENT NO. 4  
TO AGREEMENT ICS-FY-99-52  
(Insert Agreement Number or Other Identifying Information)

This Supplemental Agreement No. 4, executed on the respective dates indicated below, is effective as of June 29, 2002, between the \_\_\_\_\_  
Department of Accounting and General Services, State of Hawaii  
(Insert Name of State Department, Agency, Board or Commission)  
(hereinafter "STATE"), by its Comptroller  
(Insert Title of State Officer Executing Agreement)  
whose address is 1151 Punchbowl Street, Honolulu, Hawaii 96813  
\_\_\_\_\_, and  
Unique Computer Systems, Inc. dba The Lange Group (hereinafter "CONTRACTOR"),  
a Corporation  
(Insert "Corporation", "Partnership", "Joint Venture", "Sole Proprietorship", or other legal form of the Contractor)  
under the laws of the State of Hawaii, whose business address and taxpayer  
identification number are as follows: 1100 Ward Avenue, Suite 1050, Honolulu, Hawaii 96814  
Taxpayer id: 1019306

**RECITALS**

A. WHEREAS, the STATE and the CONTRACTOR entered into an Agreement  
ICS-FY-99-52 for Services to Develop and Implement a Replacement Land Court  
(Insert Agreement Number or other Identifying Information)  
and Regular Automated Tracking Systems for the State of Hawaii  
dated January 18 / 192000, which was amended by Supplemental Agreement  
No(s). 1, 2, 3, dated June 29, 2000, June 1, 2001 (hereinafter collectively  
and December 30, 2001  
referred to as "Agreement") whereby the CONTRACTOR agreed to provide the goods and services  
described in the Agreement, and

B. WHEREAS, the parties now desire to amend the Agreement.

NOW, THEREFORE, the STATE, and the CONTRACTOR mutually agree

to amend the Agreement as follows:

(CHECK APPLICABLE BOX(ES))

- Amend the SCOPE OF SERVICES according to the terms set forth in Attachment S1, which is attached hereto and is incorporated herein.
- Amend the TIME OF PERFORMANCE according to the terms set forth in Attachment S2, which is attached hereto and is incorporated herein.
- Amend the COMPENSATION AND PAYMENT SCHEDULE according to the terms set forth in Attachment S3, which is attached hereto and is incorporated herein.
- Amend the SPECIAL CONDITIONS according to the terms set forth in the Supplemental Special Conditions, which is attached hereto and incorporated herein.
- Recognize the CONTRACTOR's change of name.

FROM:

\_\_\_\_\_  
\_\_\_\_\_  
\_\_\_\_\_

TO:

\_\_\_\_\_  
\_\_\_\_\_  
\_\_\_\_\_

As set forth in the documents attached hereto as Exhibit \_\_\_\_\_, and incorporated herein.

A tax clearance certificate from the State of Hawaii  is  is not required to be submitted to the STATE prior to commencing any performance under this Supplemental Agreement.

A tax clearance certificate from the Internal Revenue Service  is  is not required to be submitted to the STATE prior to commencing any performance under this Supplemental Agreement.

Unless amended herein, the Agreement shall remain in full force and effect.

IN VIEW OF THE ABOVE, the STATE and the CONTRACTOR execute this Supplemental Agreement No. 4 by their signatures on the dates below.

STATE:

By   
Print Name Glenn M. Okimoto  
Title Comptroller  
Date JUN 13 2002

FUNDING AGENCY: (to be signed by head of funding agency if other than the Contracting Agency)

By \_\_\_\_\_  
Print Name \_\_\_\_\_  
Title \_\_\_\_\_  
Date \_\_\_\_\_

CONTRACTOR:

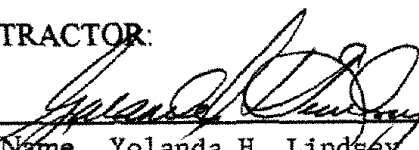
By  LS  
Print Name Yolanda H. Lindsey  
Title President \*  
Date May 29, 2002

\*Evidence of authority of the Contractor's representative to sign this Supplemental Agreement must be attached.

APPROVED AS TO FORM:

  
Deputy Attorney General

**TIME OF PERFORMANCE**

Pursuant to the Request For Proposals, Special Provisions, TERM OF CONTRACT, the Agreement is extended to December 31, 2002.

500726



CONTRACTOR'S ACKNOWLEDGMENT

State of HAWAII )  
 )  
City            County of Honolulu )

SS.

On this 29th day of May, 2002, before me personally  
appeared --YOLANDA H. LINDSEY--, to me personally known, who being by me  
duly sworn, did say that he/she is the --PRESIDENT-- of  
--Unique Computer Systems, Inc., dba THE LANGE GROUP--, the  
CONTRACTOR named in the foregoing instrument, and that he/she is authorized to sign said  
instrument on behalf of the CONTRACTOR, and acknowledges that he/she executed said instrument  
as the free act and deed of the CONTRACTOR.

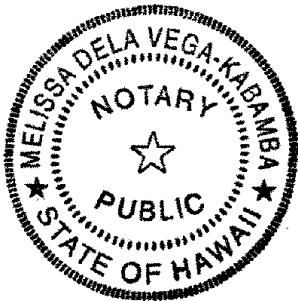

Melissa DeLa Vega-Kabamba  
Notary Public, MELISSA DELA VEGA-KABAMBA  
My Commission Expires: 7/1/05

## STANDARDS OF CONDUCT DECLARATION

For the purposes of this declaration:

"Agency" means and includes the State, the legislature and its committees, all executive departments, boards, commissions, committees, bureaus, offices, the University of Hawaii, and all independent commissions and other establishments of the state government but excluding the courts.

"Controlling interest" means an interest in a business or other undertaking which is sufficient in fact to control, whether the interest is greater or less than fifty per cent (50%).

"Employee" means any nominated, appointed, or elected officer or employee of the State, including members of boards, commissions, and committees, and employees under contract to the State or of the constitutional convention, but excluding legislators, delegates to the constitutional convention, justices, and judges.

On behalf of Unique Computer Systems, Inc.  
dba THE LANGE GROUP, CONTRACTOR, the undersigned does declare as follows:

1. CONTRACTOR  is\*  is not a legislator or an employee or a business in which a legislator or an employee has a controlling interest.
2. CONTRACTOR has not been assisted or represented by a legislator or employee for a fee or other compensation to obtain this Agreement and will not be assisted or represented by a legislator or employee for a fee or other compensation in the performance of the Agreement, if the legislator or employee had been involved in the development or award of the Agreement.
3. CONTRACTOR has not been assisted or represented for a fee or other compensation in the award of this Agreement by an Agency employee or, in the case of the Legislature, by a legislator.
4. CONTRACTOR has not been represented or assisted personally on matters related to the Agreement by a person who has been an employee of the Agency within the preceding two (2) years and who participated while in state office or employment on the matter with which the Agreement is directly concerned.
5. CONTRACTOR has not been represented or assisted on matters related to this Agreement, for a fee or other consideration by an individual who, within the past twelve (12) months, has been an Agency employee, or in the case of the Legislature, a legislator.

\* **Reminder to Agency:** If "is" block is checked, the Agency is required, under section 84-15, HRS, to post a notice of its intent to award the contract and file a copy of the notice with the State Ethics Commission, ten (10) days before entering into the Contract.

6. CONTRACTOR has not been represented or assisted in the award of this Agreement for a fee or other consideration by an individual who, a) within the past twelve (12) months, served as an Agency employee or in the case of the Legislature, a legislator, and b) participated while an employee or legislator on matters related to this Agreement.

CONTRACTOR understands that the Agreement to which this document is attached is voidable on behalf of the STATE if this Agreement was entered into in violation of any provision of chapter 84, HRS, commonly referred to as the Code of Ethics, including the provisions which are the source of the declarations above. Additionally, any fee, compensation, gift, or profit received by any person as a result of a violation of the Code of Ethics may be recovered by the STATE.

DATED: Honolulu, Hawaii, May 29, 2002

**CONTRACTOR**

Unique Computer Systems, Inc.  
dba THE LANGE GROUP

*(Insert Name of Contractor)*

  
*(Signature)*

Yolanda H. Lindsey

*(Print Name)*

President

*(Print Title)*

May 29, 2002

*(Date)*

\* **Reminder to Agency:** If "is" block is checked, the Agency is required, under section 84-15, HRS, to post a notice of its intent to award the contract and file a copy of the notice with the State Ethics Commission, ten (10) days before entering into the Contract.

500729

**CERTIFICATION OF EXEMPTION FROM CIVIL SERVICE**

**1. By Heads of State Departments or Agencies Pursuant to Delegation of the Director of Human Resources Development<sup>1</sup>**

Pursuant to the delegation of the authority by the Director of Human Resources Development, I certify that the services provided under this Agreement, and the person(s) providing the services under this Agreement are exempt from the civil service, pursuant to Hawaii Revised Statutes §76-16.

  
\_\_\_\_\_  
(signature)

JUN 13 2002  
\_\_\_\_\_  
(date)

Glenn M. Okimoto  
\_\_\_\_\_  
Print Name

Comptroller  
\_\_\_\_\_  
Print Title

**2. By the Director of Human Resources Development, State of Hawaii<sup>2</sup>**

I certify that the services provided under this Agreement, and the person(s) providing the services under this Agreement are exempt from the civil service, pursuant to Hawaii Revised Statutes §76-16( ).

\_\_\_\_\_  
(signature)

\_\_\_\_\_  
(date)

\_\_\_\_\_  
Print Name

\_\_\_\_\_  
Print Title, if designee of Director  
of Human Resources Development

<sup>1</sup>This part of the form may be used by all department heads and others to whom the Director of Human Resources Development has delegated authority to certify Hawaii Revised Statutes section 76-16 civil service exceptions. The specific paragraph(s) of section 76-16 upon which an exemption is based should be noted in the contract file. NOTE: Authority to certify exceptions under Hawaii Revised Statutes sections 76-16(2) and 76-16(3) has not been delegated; only the Director of Human Resources Development may certify sections 76-16(2) and 76-16(3) exceptions.

<sup>2</sup>This part of the form may be used only by the Director of Human Resources Development or the Director's designee. See NOTE at footnote 1.

LINDA LINGLE  
GOVERNOR



**FILE**

RUSS K. SAITO  
Comptroller

KATHERINE H. THOMASON  
Deputy Comptroller

STATE OF HAWAII  
DEPARTMENT OF ACCOUNTING  
AND GENERAL SERVICES  
P.O. BOX 119  
HONOLULU, HAWAII 96810-0119

February 21, 2003

*Recd  
2-27-03*

Ms. Nani Lindsey  
The Lange Group  
1100 Ward Avenue, Suite 1050  
Honolulu, HI 96814

Dear Ms. Lindsey:

Subject: ICS-FY-99-52 Supplemental Agreement No. 5  
Services to Develop and Implement a Replacement Land Court and Regular  
Automated Tracking System for the State of Hawaii

Enclosed is a fully executed copy of ICS-FY-99-52 Supplemental Agreement No. 5 for your files.

If you have any questions, please call Mrs. Barbara Tom of the Planning and Project Management Office, at 586-1920, extension 309.

Sincerely,

A handwritten signature in black ink, appearing to read "Lester M. Nakamura".

LESTER M. NAKAMURA, Administrator  
Information and Communication  
Services Division

*fax to Dennis Takahashi*

Enclosure

500731

FILE  
msd  
2-27-03

STATE OF HAWAII  
SUPPLEMENTAL AGREEMENT NO. 5  
TO AGREEMENT ICS-FY-99-52  
(Insert Agreement Number or Other Identifying Information)

This Supplemental Agreement No. 5, executed on the respective dates indicated below, is effective as of December 30, 192002, between the \_\_\_\_\_

Department of Accounting and General Services, State of Hawaii  
(Insert Name of State Department, Agency, Board or Commission)  
(hereinafter "STATE"), by its Comptroller  
(Insert Title of State Officer Executing Agreement)  
whose address is 1151 Punchbowl Street, Honolulu, Hawaii 96813

\_\_\_\_\_, and  
Unique Computer Systems, Inc. dba The Lange Group (hereinafter "CONTRACTOR"),  
a Corporation  
(Insert "Corporation", "Partnership", "Joint Venture", "Sole Proprietorship", or other legal form of the Contractor)

under the laws of the State of Hawaii, whose business address and taxpayer identification number are as follows: 1100 Ward Avenue, Suite 1050, Honolulu, Hawaii 96814  
Taxpayer id: 1019306

**RECITALS**

A. WHEREAS, the STATE and the CONTRACTOR entered into an Agreement ICS-FY-99-52 for Services to Develop and Implement a Replacement Land Court  
(Insert Agreement Number or other Identifying Information)  
and Regular Automated Tracking Systems for the State of Hawaii  
dated January 18, 192000, which was amended by Supplemental Agreement  
No(s). 1, 2, 3, 4, dated June 29, 2000, June 1, 2001 (hereinafter collectively  
December 30, 2001, and June 30, 2003  
referred to as "Agreement") whereby the CONTRACTOR agreed to provide the goods and services described in the Agreement, and

B. WHEREAS, the parties now desire to amend the Agreement.

NOW, THEREFORE, the STATE, and the CONTRACTOR mutually agree

to amend the Agreement as follows:

(CHECK APPLICABLE BOX(ES))

- Amend the SCOPE OF SERVICES according to the terms set forth in Attachment S1, which is attached hereto and is incorporated herein.
- Amend the TIME OF PERFORMANCE according to the terms set forth in Attachment S2, which is attached hereto and is incorporated herein.
- Amend the COMPENSATION AND PAYMENT SCHEDULE according to the terms set forth in Attachment S3, which is attached hereto and is incorporated herein.
- Amend the SPECIAL CONDITIONS according to the terms set forth in the Supplemental Special Conditions, which is attached hereto and incorporated herein.
- Recognize the CONTRACTOR's change of name.

FROM:

\_\_\_\_\_  
\_\_\_\_\_

TO:

\_\_\_\_\_  
\_\_\_\_\_

As set forth in the documents attached hereto as Exhibit \_\_\_\_\_, and incorporated herein.

A tax clearance certificate from the State of Hawaii  is  is not required to be submitted to the STATE prior to commencing any performance under this Supplemental Agreement.

A tax clearance certificate from the Internal Revenue Service  is  is not required to be submitted to the STATE prior to commencing any performance under this Supplemental Agreement.

Unless amended herein, the Agreement shall remain in full force and effect.

IN VIEW OF THE ABOVE, the STATE and the CONTRACTOR execute this Supplemental Agreement No. 5 by their signatures on the dates below.

STATE:

By Russ K. Sait  
Print Name Walter Albert Evans Wayne M. Hoyle Russ K. Sait  
Title Comptroller ACTING Comptroller  
Date 2/19/03

FUNDING AGENCY: (to be signed by head of funding agency if other than the Contracting Agency)

By \_\_\_\_\_  
Print Name \_\_\_\_\_  
Title \_\_\_\_\_  
Date \_\_\_\_\_

CONTRACTOR:

By Yolanda H. Lindsey  
Print Name YOLANDA H. LINDSEY  
Title PRESIDENT \*  
Date DEC. 16, 2002

\*Evidence of authority of the Contractor's representative to sign this Supplemental Agreement must be attached.

APPROVED AS TO FORM:

Diane Jackson  
Deputy Attorney General

500734



CONTRACTOR'S ACKNOWLEDGMENT

State of Hawaii  
3 City of Honolulu County of

SS.

On this 16<sup>th</sup> day of December, 8<sup>th</sup> 19 2002, before me personally

appeared Yolanda H. Lindsey, to me personally known, who being by me  
duly sworn, did say that he/she is the President of

Unique Computer Systems Inc, dba the Lange Group, the

CONTRACTOR named in the foregoing instrument, and that he/she is authorized to sign said  
instrument on behalf of the CONTRACTOR, and acknowledges that he/she executed said instrument  
as the free act and deed of the CONTRACTOR.

18

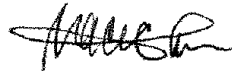

Notary Public, STACIE I. IKEI  
My Commission Expires: 11-6-06

500735

**TIME OF PERFORMANCE**

Pursuant to the Request For Proposals, Special Provisions, TERM OF CONTRACT, the Agreement is extended to June 30, 2003.

500736

## STANDARDS OF CONDUCT DECLARATION

For the purposes of this declaration:

"Agency" means and includes the State, the legislature and its committees, all executive departments, boards, commissions, committees, bureaus, offices, the University of Hawaii, and all independent commissions and other establishments of the state government but excluding the courts.

"Controlling interest" means an interest in a business or other undertaking which is sufficient in fact to control, whether the interest is greater or less than fifty per cent (50%).

"Employee" means any nominated, appointed, or elected officer or employee of the State, including members of boards, commissions, and committees, and employees under contract to the State or of the constitutional convention, but excluding legislators, delegates to the constitutional convention, justices, and judges.

On behalf of Unique Computer Systems, Inc.  
dba THE LANGE GROUP, CONTRACTOR, the undersigned does declare as follows:

1. CONTRACTOR is\* is not a legislator or an employee or a business in which a legislator or an employee has a controlling interest.
2. CONTRACTOR has not been assisted or represented by a legislator or employee for a fee or other compensation to obtain this Agreement and will not be assisted or represented by a legislator or employee for a fee or other compensation in the performance of the Agreement, if the legislator or employee had been involved in the development or award of the Agreement.
3. CONTRACTOR has not been assisted or represented for a fee or other compensation in the award of this Agreement by an Agency employee or, in the case of the Legislature, by a legislator.
4. CONTRACTOR has not been represented or assisted personally on matters related to the Agreement by a person who has been an employee of the Agency within the preceding two (2) years and who participated while in state office or employment on the matter with which the Agreement is directly concerned.
5. CONTRACTOR has not been represented or assisted on matters related to this Agreement, for a fee or other consideration by an individual who, within the past twelve (12) months, has been an Agency employee, or in the case of the Legislature, a legislator.

\* Reminder to Agency: If "is" block is checked, the Agency is required, under section 84-15, HRS, to post a notice of its intent to award the contract and file a copy of the notice with the State Ethics Commission, ten (10) days before entering into the Contract.

500737

6. CONTRACTOR has not been represented or assisted in the award of this Agreement for a fee or other consideration by an individual who, a) within the past twelve (12) months, served as an Agency employee or in the case of the Legislature, a legislator, and b) participated while an employee or legislator on matters related to this Agreement.

CONTRACTOR understands that the Agreement to which this document is attached is voidable on behalf of the STATE if this Agreement was entered into in violation of any provision of chapter 84, HRS, commonly referred to as the Code of Ethics, including the provisions which are the source of the declarations above. Additionally, any fee, compensation, gift, or profit received by any person as a result of a violation of the Code of Ethics may be recovered by the STATE.

DATED: Honolulu, Hawaii, DEC. 16, 2002

**CONTRACTOR**

Unique Computer Systems, Inc.  
dba THE LANGE GROUP

*(Insert Name of Contractor)*

  
*(Signature)*

Yolanda H. Lindsey

*(Print Name)*

President

*(Print Title)*

December 16, 2002

*(Date)*

\* **Reminder to Agency:** If "is" block is checked, the Agency is required, under section 84-15, HRS, to post a notice of its intent to award the contract and file a copy of the notice with the State Ethics Commission, ten (10) days before entering into the Contract.

500738

**CERTIFICATION OF EXEMPTION FROM CIVIL SERVICE**

1. **By Heads of State Departments or Agencies Pursuant to Delegation of the Director of Human Resources Development<sup>1</sup>**

Pursuant to the delegation of the authority by the Director of Human Resources Development, I certify that the services provided under this Agreement, and the person(s) providing the services under this Agreement are exempt from the civil service, pursuant to Hawaii Revised Statutes §76-16.

Russ K. Saito  
(signature)

2/19/03  
(date)

Russ K. Saito

Wahy/Alie/Byap Wahy/Alie/Alie/Alie

Print Name

Comptroller AC/Alie/Comptroller

Print Title

2. **By the Director of Human Resources Development, State of Hawaii<sup>2</sup>**

I certify that the services provided under this Agreement, and the person(s) providing the services under this Agreement are exempt from the civil service, pursuant to Hawaii Revised Statutes §76-16( ).

\_\_\_\_\_  
(signature)

\_\_\_\_\_  
(date)

\_\_\_\_\_  
Print Name

\_\_\_\_\_  
Print Title, if designee of Director  
of Human Resources Development

<sup>1</sup>This part of the form may be used by all department heads and others to whom the Director of Human Resources Development has delegated authority to certify Hawaii Revised Statutes section 76-16 civil service exceptions. The specific paragraph(s) of section 76-16 upon which an exemption is based should be noted in the contract file. NOTE: Authority to certify exceptions under Hawaii Revised Statutes sections 76-16(2) and 76-16(3) has not been delegated; only the Director of Human Resources Development may certify sections 76-16(2) and 76-16(3) exceptions.

<sup>2</sup>This part of the form may be used only by the Director of Human Resources Development or the Director's designee. See NOTE at footnote 1.

500739

# The Lange Group

Software Systems Analysis & Telecommunications Consulting

## CERTIFICATION OF CORPORATE RESOLUTION

The undersigned, being the corporate secretary of Unique Computer Systems, Inc., dba The Lange Group, a Hawaii corporation, do hereby certify that the following is a full, true and correct copy of a resolution duly adopted by the Board of Directors of said Corporation, at a meeting duly called and held on the eighteenth day of January 2002 at it's offices at 1100 Ward Avenue, Suite 1050, Honolulu, Hawaii 96814, at which a quorum was present, and acting throughout, and that said resolution has not been modified, amended or rescinded and continues in full force and effect:

"RESOLVED that any individual at the time of holding the position of President of this corporation, is hereby authorized to execute on behalf of the Corporation, any bid, proposal, contract, agreement, bonds, surety bonds, and other documents and instruments required by any such bid, proposal, or contract, for software and consulting services to be performed by the Corporation with the State of Hawaii or any agency of department thereof.

IN WITNESS WHEREOF, I have hereunto set my hand and affixed the corporate seal of Unique Computer Systems, Inc. dba The Lange Group, on this 16th day of December, 2002 .

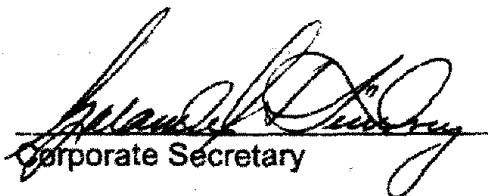
  
Corporate Secretary

(SEAL)

500740

LINDA LINGLE  
GOVERNOR



RUSS K. SAITO  
Comptroller

KATHERINE H. THOMASON  
Deputy Comptroller

STATE OF HAWAII  
DEPARTMENT OF ACCOUNTING  
AND GENERAL SERVICES  
P.O. BOX 119  
HONOLULU, HAWAII 96810-0119

July 31, 2003

*MSL*  
*8-21-03*

Ms. Nani Lindsey  
The Lange Group  
1100 Ward Avenue, Suite 1050  
Honolulu, HI 96814

Dear Ms. Lindsey:

Subject: Supplemental Agreement No. 6  
Agreement No. ICS-FY-99-52  
BOC Integrated System

Enclosed is a fully executed copy of the above referenced agreement for your file.

If you have any questions, please call Mrs. Barbara Tom, Planning and Project Management Officer, at (808) 586-1920 x 309.

Sincerely,

A handwritten signature in black ink, appearing to read "Lester M. Nakamura".

LESTER M. NAKAMURA, Administrator  
Information and Communication  
Services Division

Enclosure

500741

STATE OF HAWAII  
SUPPLEMENTAL AGREEMENT NO. 6  
TO AGREEMENT ICS-FY-99-52  
(Insert Agreement Number or Other Identifying Information)

This Supplemental Agreement No. 6, executed on the respective dates indicated below, is effective as of June 30, 2003, between the Department of Accounting and General Services, State of Hawaii  
(Insert Name of State Department, Agency, Board or Commission)  
(hereinafter "STATE"), by its Comptroller whose address is  
(Insert Title of State Officer Executing Agreement)  
1151 Punchbowl Street; Honolulu, Hawaii 96813, and  
Unique Computer Systems, Inc. dba The Lange Group (hereinafter "CONTRACTOR"),  
a Corporation  
(Insert "Corporation", "Partnership", "Joint Venture", "Sole Proprietorship", or other legal form of the Contractor)  
under the laws of the State of Hawaii, whose business address and taxpayer identification number are as follows: 1100 Ward Avenue, Suite 1050; Honolulu, Hawaii 96814  
Taxpayer ID: 1019306

RECITALS

A. WHEREAS, the STATE and the CONTRACTOR entered into an Agreement ICS-FY-99-52 for Services to Develop and Implement a Replacement Land Court and Regular Automated Tracking System for the State of Hawaii  
(Insert Agreement Number or other Identifying Information)  
dated January 18, 2000, which was amended by Supplemental Agreement No(s) 1, 2, 3, 4 & 5  
06/29/00, 06/01/01,  
dated 12/30/01, 06/30/02 & (hereinafter collectively referred to as "Agreement") whereby the  
12/30/02  
CONTRACTOR agreed to provide the goods and services described in the Agreement, and

B. WHEREAS, the parties now desire to amend the Agreement.

NOW, THEREFORE, the STATE, and the CONTRACTOR mutually agree to amend the Agreement as follows:



(CHECK APPLICABLE BOX(ES))

- Amend the SCOPE OF SERVICES according to the terms set forth in Attachment S1, which is attached hereto and is incorporated herein.
- Amend the TIME OF PERFORMANCE according to the terms set forth in Attachment S2, which is attached hereto and is incorporated herein.
- Amend the COMPENSATION AND PAYMENT SCHEDULE according to the terms set forth in Attachment S3, which is attached hereto and is incorporated herein.
- Amend the SPECIAL CONDITIONS according to the terms set forth in the Supplemental Special Conditions, which is attached hereto and incorporated herein.
- Recognize the CONTRACTOR's change of name.

FROM:

\_\_\_\_\_  
\_\_\_\_\_  
\_\_\_\_\_  
\_\_\_\_\_

TO:

\_\_\_\_\_  
\_\_\_\_\_  
\_\_\_\_\_  
\_\_\_\_\_

As set forth in the documents attached hereto as Exhibit \_\_\_\_\_, and incorporated herein.

500743

A tax clearance certificate from the State of Hawaii  is  is not required to be submitted to the STATE prior to commencing any performance under this Supplemental Agreement.

A tax clearance certificate from the Internal Revenue Service  is  is not required to be submitted to the STATE prior to commencing any performance under this Supplemental Agreement.

Unless amended herein, the Agreement shall remain in full force and effect.

IN VIEW OF THE ABOVE, the STATE and the CONTRACTOR execute this Supplemental

Agreement No. 6 by their signatures on the dates below.

FUNDING AGENCY: (to be signed by head of funding agency if other than the Contracting Agency)

By \_\_\_\_\_  
Print Name \_\_\_\_\_  
Title \_\_\_\_\_  
Date \_\_\_\_\_

STATE:

By Russ K Saito  
Print Name Russ K. Saito  
Title Comptroller  
Date 7/26/03

CONTRACTOR

By Yolanda H. Lindsey  
Print Name Yolanda H. Lindsey  
Title President  
Date June 27, 2003 LS

APPROVED AS TO FORM

William M. Tucker  
Deputy Attorney General

\*Evidence of authority of the Contractor's representative to sign this Supplemental Agreement must be attached.

500744

Form AG-Supp (5/99)

CONTRACTOR'S ACKNOWLEDGMENT

State of HAWAII )  
 )  
CITY & County of HONOLULU )

SS.

On this 27th day of June, 2003, before me personally appeared

Yolanda H. Lindsey, to me personally known, who being by me duly sworn, did

say that he/she/they is/are the President of Unique Computer Systems, Inc. dba THE LANGE GROUP

the CONTRACTOR named in the foregoing instrument, and that he/she/they is/are authorized to sign said instrument on behalf of the CONTRACTOR, and acknowledges that he/she/they executed said instrument as the free act and deed of the CONTRACTOR.

*[Signature]*  
GENAL PERKIN

(Print Name)  
Genal Perkin

Notary Public, State of HAWAII  
My Commission Expires: JUN 01, 2005

(NOTARY SEAL)

500745

**CERTIFICATE OF EXEMPTION FROM CIVIL SERVICE**

1. **By Heads of Departments or Agencies as Delegated by the Director of Human Resources Development(a.)**

Pursuant to a delegation of the authority by the Director of Human Resources Development, I certify that the services to be provided under this Contract, and the person(s) providing the services under this Contract are exempt from the civil service, pursuant to §76-16, Hawaii Revised Statutes (HRS).



*(Signature)*

Russ K. Saito

*(Print Name)*

Comptroller

*(Print Title)*

7/21/03

*(Date)*

- a. Item 1 of this certificate may be used by all department heads and others to whom the Director of Human Resources Development (DHRD) has delegated authority to certify §76-16, HRS, civil service exemptions. The specific paragraph(s) of §76-16, HRS, upon which an exemption is based should be noted in the contract file.

**NOTE:** If authority to certify exceptions under §§76-16(2), 76-16(3), and 76-16(15), HRS, has not been delegated, only the Director of DHRD may certify §§76-16(2), 76-16(3), and 76-16(15) exceptions.

500746

**CERTIFICATE OF EXEMPTION FROM CIVIL SERVICE**

**2. By the Director of Human Resources Development, State of Hawaii (b.)**

I certify that the services to be provided under this Contract, and the person(s) providing the services under this Contract are exempt from the civil service, pursuant to §76-16, Hawaii Revised Statutes (HRS).

\_\_\_\_\_  
*(Signature)*

\_\_\_\_\_  
*(Print Name)*

\_\_\_\_\_  
*(Print Title, if designees of the Director of DHRD)*

\_\_\_\_\_  
*(Date)*

- b. Item 2 of this certificate may be used only by the Director of Human Resources Development (DHRD) or the Director's designee.

**NOTE:** If authority to certify exceptions under §§76-16(2), 76-16(3), and 76-16(15), HRS, has not been delegated, only the Director of DHRD may certify §§76-16(2), 76-16(3), and 76-16(15) exceptions.

500747

## STANDARDS OF CONDUCT DECLARATION

For the purposes of this declaration:

"Agency" means and includes the State, the legislature and its committees, all executive departments, boards, commissions, committees, bureaus, offices, the University of Hawaii, and all independent commissions and other establishments of the state government but excluding the courts.

"Controlling interest" means an interest in a business or other undertaking which is sufficient in fact to control, whether the interest is greater or less than fifty per cent (50%).

"Employee" means any nominated, appointed, or elected officer or employee of the State, including members of boards, commissions, and committees, and employees under contract to the State or of the constitutional convention, but excluding legislators, delegates to the constitutional convention, justices, and judges.

Unique Computer Systems, Inc.

On behalf of dba THE LANGE GROUP, CONTRACTOR, the undersigned does declare as follows:

1. CONTRACTOR ~~is~~ (is not) a legislator or an employee or a business in which a legislator or an employee has a controlling interest.\*
2. CONTRACTOR has not been assisted or represented by a legislator or employee for a fee or other compensation to obtain this Agreement and will not be assisted or represented by a legislator or employee for a fee or other compensation in the performance of the Agreement, if the legislator or employee had been involved in the development or award of the Agreement.
3. CONTRACTOR has not been assisted or represented for a fee or other compensation in the award of this Agreement by an Agency employee or, in the case of the Legislature, by a legislator.
4. CONTRACTOR has not been represented or assisted personally on matters related to the Agreement by a person who has been an employee of the Agency within the preceding two (2) years and who participated while in state office or employment on the matter with which the Agreement is directly concerned.
5. CONTRACTOR has not been represented or assisted on matters related to this Agreement, for a fee or other consideration by an individual who, within the past twelve (12) months, has been an Agency employee, or in the case of the Legislature, a legislator.
6. CONTRACTOR has not been represented or assisted in the award of this Agreement for a fee or other consideration by an individual who, a) within the past twelve (12) months, served as an Agency employee or in the case of the Legislature, a legislator, and b) participated while an employee or legislator on matters related to this Agreement.

500748

Form AG-Supp (5/99)

CONTRACTOR understands that the Agreement to which this document is attached is voidable on behalf of the STATE if this Agreement was entered into in violation of any provision of chapter 84, HRS, commonly referred to as the Code of Ethics, including the provisions which are the source of the declarations above. Additionally, any fee, compensation, gift, or profit received by any person as a result of a violation of the Code of Ethics may be recovered by the STATE.

DATED: Honolulu, Hawaii, June 27, 2003

**CONTRACTOR**

Unique Computer Systems, Inc.  
dba THE LANGE GROUP

*(Insert name of Contractor)*

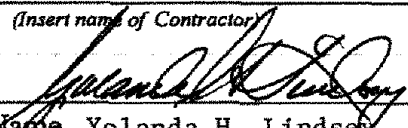
By   
Print Name Yolanda H. Lindsee  
Title President

\*Reminder to Agency: If "is" is circled, the Agency is required, under section 84-15, HRS, to file with the State Ethics Commission, ten (10) days before the Agreement is entered into, a written justification as to why the Agreement was not required to be competitively bid.

500749

TIME OF PERFORMANCE

Pursuant to the Request For Proposals, Special Provisions, TERM OF CONTRACT, the Agreement is extended to December 30, 2003.

This extension of time only for a six-month period is necessary to allow the vendor to remain on-call to fix any problems that arise that may be related to the Internet functions of the new BOC system.

500750



BENJAMIN J. CAYETANO  
GOVERNOR OF HAWAII



CARL T. WATANABE  
ACTING REGISTRAR OF CONVEYANCES

TELEPHONE (808) 587-0120

FAX (808) 587-0136

STATE OF HAWAII  
DEPARTMENT OF LAND AND NATURAL RESOURCES  
BUREAU OF CONVEYANCES

P. O. BOX 2867  
HONOLULU HAWAII 96803

*Handwritten note:*  
filed  
9-29-00  
Carl (Watanabe)

MEMORANDUM

Date: September 26, 2000  
To: Barbara Tom  
Fr: Carl Watanabe *[Signature]*  
Re: RFP-ICS-FY-99-052, Supplemental Agreement Concerns

After reviewing the concerns raised by Diane Erickson, we forward our comments in the hopes of trying to resolve some of the issues currently facing us.

As you are aware, delays in our selection process required us to make changes to the significant dates reflected in the RFP to accomplish this project within a reasonable amount of time. The last amendment being Addendum #9 dated September 19, 2000 (Attachment A). Further, by letter to the bidders dated November 1, 1999 (Attachment B) the phases again were defined and made subject to the availability of funding with the period for completion as agreed to by the contractor and the Bureau. With this November 1, 1999 letter to the bidders provide for proper notice as to determining date of expiration. I also noticed the significant dates used in the initial contract is not the amended one that shows only certain tasks to be completed by June 2000.

Proceeding with the selection process, we selected the finalists for best and final offers in October 1999. Continuing with the process, we selected our successful vendors in November 1999. In December 1999, pursuant to the provisions of the RFP that work would progress based on the availability of funds, we met with the vendors to structure the completion of phases and payments (Attachment C). Attached Attachment D is the proposed funding worksheet that represents what had been agreed to. The initial contract to fund our first phase (Task 1, 2, 4, 5, and portion of 3) was dated January 18, 2000 and reflected a date of June 30, 2000 for project completion. What was not anticipated was the long delay in getting everything approved. By the time the contract was finally approved by pre-audit,

500751

we were already in June. Based on these delays, we met with Nani Lindsey of the Lange Group to resolve completion milestones and payments. This is attached to this correspondence. Although we were able to notify the vendors to proceed with the contract, we had problems in encumbering the funds due to questions by pre-audit (Attachment E). I hope we will not have similar problems with this new contract. We have been trying to push this project to make up lost time, but are at a point, without the new contract, additional hardware critical to our completion, cannot be ordered.

I suppose at this point, our question remains, what needs to be done to make things okay. We don't believe there is a problem with the selection. We feel the terms of the RFP and manner in which contracts would be issued were made clear in discussions with the final vendors.

In attempting to put this project together, we were well aware of funding concerns. This was discussed many times and our first attempt to select a vendor had to be canceled because of funding limitations. Because of this, it was my understanding that the second RFP was properly crafted to address this problem. There also seems to be another perspective in pre-audit that we are not doing things properly. With so many people reviewing what is being done, how do we determine what is "proper"?

As you indicated to Diane Erickson, the completion of our project depends on us funding future phases. Time is of the essence and we seek your assistance to resolve this delay. Do you think the recap of events reflected in this memo would be useful to Diane?

500752

A

STATE OF HAWAII  
DEPARTMENT OF ACCOUNTING AND GENERAL SERVICES  
INFORMATION AND COMMUNICATION SERVICES DIVISION

HONOLULU, HAWAII

September 17, 1999

ADDENDUM 9  
TO  
RFP NO. ICS-FY-99-052

SERVICES TO DEVELOP AND IMPLEMENT A REPLACEMENT  
LAND COURT AND REGULAR AUTOMATED TRACKING SYSTEM  
FOR THE STATE OF HAWAII

The following changes are hereby made:

1. Replace page 8 (Final September 1, 1999). The following change has been made to the Significant Dates:
  - a. Additional language is inserted following the Significant Dates heading as follows:

The delivery and work schedule set out herein represents the State's best estimate of the schedule that will be followed. If a component of this schedule, is delayed, the rest of the schedule may be shifted by the same number of days. The approximate schedule is as follows:
  - b. Discussions (if any) with Priority Listed Offerors have been postponed until after September 27, 1999.
2. Replace Appendix G, Addendum Log.

This addendum is being published to accommodate a need by the BOC to postpone (or halt) the RFP process and schedule pending the resolution of a protest as required by the Hawaii Administrative Rules.

  
\_\_\_\_\_  
Lester M. Nakamura, Administrator  
Information and Communication Services Division

500753

## 2.3 SIGNIFICANT DATES

The delivery and work schedule set out herein represents the State's best estimate of the schedule that will be followed. If a component of this schedule, such as Proposals Due date is delayed, the rest of the schedule may be shifted by the same number of days. The approximate schedule is as follows: All time is shown as Hawaiian Standard Time (HST)

Advertisement of RFP and Proposal Pick-up	April 5, 1999
Optional Site Visit	April 6 to May 18, 1999
Deadline for Written Inquiries; 10:00 a.m.	April 19, 1999
Deadline for Request to Utilize Another Methodology	April 19, 1999
Deadline for Letter of Intent; 10:00 a.m.	April 21, 1999
Response to Offerors' Written Inquiries	May 5, 1999
Deadline for a Additional Written Inquiries	May 7, 1999
Response to Offerors' Additional Written Inquiries	May 12, 1999
Deadline for a Next Additional Written Inquiries	May 14, 1999
Response to Offerors' Additional Written Inquiries	May 19, 1999
Proposal Due; 10:00 a.m.	May 28, 1999
Compliance Review for Proposals	June 1, to June 9, 1999
Notices of Compliance Qualification or Disqualification Mailed	June 10, 1999
Selection of Priority Listed Offerors	August 6, 1999
Discussions (if any) with Priority Listed Offerors	August 16, 1999 to October 8, 1999
Best and Final Offer Due; 10:00 a.m.	<del>October 25, 1999</del> Nov 15, 1999
Contractor Selection	November 1, 1999
Estimated Date of Contract Issuance	Dec November 12, 1999
Estimated Start Date	November 22, 1999
Work Plan Presentation for PART 1	December 6, 1999
Work Plan Presentation for PART 2	December 6, 1999
Final Work Plan Submission for PART 1	December 13, 1999
Final Work Plan Submission for PART 2	December 13, 1999

500754

**PROPOSAL PREPARATION**

---

Estimated Initial Contract Period for Part1 Tasks 1-6

*ke* November-22, 1999  
to June 15, 2000

Estimated Completion Date all Phases

March 31, 2001

Estimated Completion; Post Implementation Support

March 31, 2005

500755

## APPENDIX G

---

### ADDENDUM LOG

The following Addenda have been issued:

<u>Addendum-id</u>	<u>Addendum Title</u>	<u>Issue Date</u>
Addendum 1	Clarifications, Reply to Offeror's Written Inquiries	May 5, 1999
Addendum 2	Reply to Offeror's Additional Written Inquiries	May 12, 1999
Addendum 3	Change to Significant Dates And Reply to (more) Offeror's Written Inquiries	May 19, 1999
Addendum 4	Correct Compliance Review, Substantive Review Scoring, And Transmittal Letter Sample	June 7, 1999
Addendum 5	Change to Significant Dates	June 23, 1999
Addendum 6	Change to Significant Dates And Notice of Consolidated Server	July 23, 1999
Addendum 7	Change to Significant Dates and Correct RFP Price Language	August 26, 1999
Addendum 8	Change to Significant Dates	September 9, 1999
Addendum 9	Change to Significant Dates	September 9, 1999

End-of-log-entries.

500756

BENJAMIN J. CAYETANO  
GOVERNOR



RAYMOND H. SATO  
COMPTROLLER

MARY PATRICIA WATERHOUSE  
DEPUTY COMPTROLLER

**STATE OF HAWAII**  
**DEPARTMENT OF ACCOUNTING**  
**AND GENERAL SERVICES**

P.O. BOX 119  
HONOLULU, HAWAII 96810-0119

November 1, 1999

Ms. Nani Lindsey  
THE LANGE GROUP  
1100 Ward Avenue, Suite 1050  
Honolulu, Hawaii 96814

Facsimile: (808) 599-5264

Dear Ms. Lindsey:

Re: RFP ICS-FY-99-052, PART 1

Please submit a Best and Final Offer to the Information and Communication Services Division, attention Barbara Tom by 10:00 a. m. on November 15, 1999, based on the following additional required information of the original RFP. In your best and final, indicate your agreement or elaborate on how you plan to achieve the results desired.

1. ICSD recently installed the RS/6000 SP2 system. Leverage this recent acquisition to meet the requirements of Section 3.8 of RFP No. ICS-FY-99-052.
2. Price schedule is to be based on an amendment to Section 3.10, IMPLEMENTATION PLAN, paragraph 1, to state:

"The minimum expected to be completed in the initial contract period for Part 1 consists of phases determined as Phase 1 (tasks 1-3), Phase 2 (tasks 4-5), Phase 3 (tasks 6-7), Phase 4 (tasks 8-9), Phase 5 (task 10), and Phase 6 (task 11) will be contracted based upon available funding. Part 2 (task 12) will also be awarded and contracted based on availability of funding. Any remaining work shall then be contracted as supplemental agreements for phases based on available funding."

Please provide your pricing based on the above changes.

3. The RFP is further amended to replace Appendix B, Page B-1 (Final May 3, 1999), to correct the TERM OF CONTRACT, sentence one to state:

"Term of contract shall be initially, and subsequently, for a period agreed upon by the contractor and the Bureau of Conveyances (BOC) to complete the work required for all phases contracted."

500757

Appendix B, Page B-1 (Final May 3, 1999), METHOD OF AWARD, is also amended by adding:

"Award to be based on substantive evaluation by the Project Review Committee. Execution of Contract and Notice to Proceed will be in the manner provided for in the implementation phases. However, Notice to Proceed may be accelerated but not necessarily in the sequence described in Section 3.10 as amended."

Will this pose a problem for you?

4. Immediate and timely remediation of the new system is critical to our public servicing requirements. Programming and technical assistance located in Honolulu supports this need. Please provide a detailed schedule of post implementation charges to ensure reliable on-site response and long term support. Charges should also reflect hardware and software support that includes but is not limited to license fees, maintenance and support fees, and any recurring charges anticipated.
5. Parallel testing of the new system will be conducted with no interruptions to operations. How will this be accomplished and will parallel testing involve the entire BOC staff?
6. The RFP calls for the migration of the current LCATS (Land Court Automated Title System) information to the BCIS. Based on the above, please elaborate on how your solution accommodates and supports this requirement.
7. Remote sites on the neighbor islands are to be fully functional. Please elaborate on your proposal, specifically equipment, communication options, hardware and software configuration requirements. Also identify potential restrictions that may be encountered. Site selections limited to Oahu (Honolulu), Kauai (Lihue), Maui (Wailuku), and Hawaii (Hilo and Kona).
8. Internet access poses security problems. Please identify the security levels included in your proposal and the problems they address. Is there a security "master" to identify different security options?

Should you have any questions, contact Barbara Tom, Planning and Project Management Officer, at (808) 586-1920.

Sincerely,

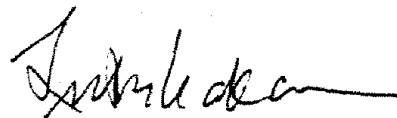

Lester M. Nakamura, Administrator  
Information and communication  
Services Division

500758



12/8/1999 meeting with Lange Group and Title Guaranty to discuss contents of proposed contract.

Pricing for Phase 1 and 2 (Tasks 1-5)

Phase 1	656,708.05
Phase 2	<u>566,338.03</u>
TOTAL	1,223,046.08

Phase 5	21,666.53
---------	-----------

\*\*\*\*\*This being considered to speed up the process to access index information. If this option is exercised, we are looking at:

TOTAL 1,244,712.61

\*\*\*\*\*Migrating the images is shown as a function of Task 7, in Phase 3. It's our desire to have BOC personnel be able to access images and data ASAP. This Task 7 may possibly be moved up. Unsure of the specific figure as it is defined as 7-b. Nani will try to determine costs for 7-b. If not, using the total figure for Task 7 of 47,167.44 would increase the contract to:

TOTAL 1,291,880.05

500759

# MEMORANDUM

Date: January 13, 2000

To: Barbara Tom

cc: Mason Young, Wayne Sasaki, Kinau Alber, Susan Okamoto, Sam Yip

Fr: Carl Watanabe

Re: RFP-ICS-FY-99-052, Contract Prices

Discussed the attached with Nani Lindsey and she has no problems with our suggested award amounts.

"A" to be awarded by June 2000 based on \$1.5 million

Contract to The Lange Group	\$1,297,668.45
Task 1 100%	
Task 2 100%	
Task 3 74%	
Task 4 100%	
Task 5 100%	
Contract to Title Guaranty First 5 years	<u>200,000.00</u>
TOTAL	<b>\$1,497,668.45</b>

"B" to be awarded in July 2000 based on approx \$400,000

Contract to The Lange Group	\$214,039.95
Task 3 18%	
Task 6 100%	
Task 7 100%	
Task 10 100%	
Contract to Title Guaranty Second 5 years	<u>200,000.00</u>
TOTAL	<b>\$414,039.95</b>

500760

"C" to be awarded in November 2000

Contract to The Lange Group	\$262,854.08
Task 3 6%	
Task 8 100%	
Task 9 100%	
Task 11 100%	
<b>TOTAL</b>	<b>\$262,854.08</b>
<b>GRAND TOTAL</b>	<b>\$2,174,562.48</b>

"D" represents post implementation support payments which can be deferred to as late as January 2001. Depending on how much is available, advance payments are discounted from the annual figures indicated in the proposal.

Post Implementation	1st Year	\$66,577.89
Post Implementation	2nd Year	<u>77,240.99</u>
<b>TOTAL</b>		<b>\$146,818.88</b>

With the above information, can we proceed with finalizing the initial award for \$1,497,668.95?

Please advise. Thank you.

500761

CONTRACT AWARD PROPOSAL

Amended Contract Award: January 11, 2000

Task Timetable	%	Payment Schedule	Amount	Due	Contract	Contract	Contract
Task 1 Implement BOC Network	10	\$ 23,051.93	2/15		"A"	"B"	"C"
Task 2 BCI's Requirement Verification	100	\$ 48,458.02	2/28	\$ 240,782.21			
Task 3 Replace REC and LC System	65	\$ 326,228.28	3/31	\$ 326,228.28			
Task 4 Imaging Capability - BOC	9	\$ 44,458.06	4/30				
	52	\$ 285,034.44	4/30				
	8	\$ 38,299.79	5/30				
	15	\$ 70,653.73	6/30				
	17	\$ 80,764.93	6/30	\$ 519,230.95			
Task 5 Imaging Capability - BCI's	55	\$ 44,739.33	7/30	\$ 81,093.28			
	45	\$ 38,353.93	7/30	\$ 81,093.28			
Task 7 Remote Access-Image Data	2/1/00 to 10/31/00						
(7b) Deliver Requirements Doc	38	\$ 17,845.73	8/31				
(7d) Completion of Prgrms & Ting	31	\$ 14,449.91	8/31				
(7) Completion of Prgrms & Ting	31	\$ 14,771.80	10/31	\$ 47,167.44			
Task 10 Data Remediation	2/1/00 to 9/30/00						
	18	\$ 3,899.87	8/15				
	49	\$ 10,583.27	9/30				
	33	\$ 7,093.29	9/30	\$ 21,666.53			
Subtotal Tasks 1-5, 7 & 10				\$ 1,461,918.47	\$ 1,297,688.45	\$ 138,648.03	
Task 6 Enable Remote - Text Data	8/1/00 to 8/31/00	100	\$ 77,393.92		\$ 77,393.92		
Task 8 Public Access - Text Data	10/1/00 to 12/31/00	100	\$ 139,472.55			\$ 139,472.55	
Task 9 Public Access - Image Data	11/1/00 to 12/31/00	100	\$ 62,027.76			\$ 62,027.76	
Task 11 GIS Study	12/1/00 to 12/31/00	100	\$ 357,497.75	\$ 312,644.01	\$ 44,853.74	\$ 33,749.78	
TOTAL Tasks 1-11				\$ 2,174,562.48	\$ 1,774,562.48		
Task 12 (1-5 years)		Title Guaranty		\$ 200,000.00	\$ 200,000.00		
Task 12 (6-10 years)		Title Guaranty		\$ 200,000.00	\$ 200,000.00		
Post Implementation Support - 1st				\$ -	\$ -	\$ 69,577.88	
TOTAL BID Tasks 1-12				\$ 2,174,562.48	\$ 2,174,562.48		
Post Implementation Support - 2nd				\$ -	\$ -	\$ 77,240.89	
CONTRACT AWARDS BY 6/00	"A"			\$ 1,497,688.45	\$ 1,497,688.45		
CONTRACT AWARDS 7/00	"B"			\$ 414,039.95	\$ 414,039.95		
CONTRACT AWARD 11/00	"C"			\$ -	\$ -	\$ 262,854.08	
TOTAL OF CONTRACTS				\$ 2,174,562.48	\$ 2,174,562.48		

500262

BENJAMIN J. CAYETANO  
GOVERNOR OF HAWAII



CARL T. WATANABE  
ACTING REGISTRAR OF CONVEYANCES

TELEPHONE (808) 587-0120

FAX (808) 587-0136

STATE OF HAWAII  
DEPARTMENT OF LAND AND NATURAL RESOURCES  
BUREAU OF CONVEYANCES

P. O. BOX 2867

HONOLULU HAWAII 96803

Date: June 2, 2000

To: Roy Hattori, DLNR Fiscal Office

Fr: Carl Watanabe

Re: RFP ICS-FY-99-052

Attached is a spreadsheet that reflects how we are awarding the contracts. The Lange Group and Title Guaranty were the successful bidders for our project. The project was broken down into two parts, Part 1 was to develop and implement the computer system and Part 2 covered the deliver 10 years of digitized images made from our microfilm library.

The Lange Group proposal was accepted at \$1,774,562.48 and Title Guaranty was the successful bidder at \$400,000.00. The total for the project was \$2,174,562.48 which does not include post-implementation charges (R&M).

The RFP was designed to allow contracts to be awarded on the basis of availability of funds. Once the successful bidders were chosen, the schedule of payments were determined as shown on the spreadsheet. Awards are based on contracting by June 2000, July 2000, and November 2000. This process was discussed and reviewed with ICSD and Deputy Attorney General Diane Erickson and deemed to be appropriate.

For fiscal year ending June 2000, we were appropriated 1.5 million which is why the awards were for \$1,497,668.45 (The Lange Group - \$1,297,668.45 and Title Guaranty - \$200,000) as shown in column "A". The balance of payments would be covered as shown in columns "B" and "C".

It is imperative that we have these contracts approved to encumber the funding this fiscal year, else we lose it.

Should there be any questions, it can probably best be answered by Barbara Tom of ICSD at 586-1920.

500763

The Lange Group  
1100 Ward Avenue, Suite 1050  
Honolulu, Hawaii 96814  
(808) 545-1822

9-21-07  
STILL OUTSTANDING.  
**FILE**

May 23, 2007

Attn: Bob Masuda, Dep. Dir  
or Dennis Ihara, Dep. Admin.  
Bureau of Conveyances  
Department of Land & Natural Resources  
1151 Punchbowl Street, Room 122  
Honolulu, Hawaii 96813

**COPY**

**INVOICE # 3089**

(SSS) APPX Software Support Subscription for the BCIS  
computer system on IBM RS/6000 AIX, 64 users (max 94 users),  
for the one year period: July 1, 2007 through June 30, 2008.  
(Note: State Parks will pay pro-rata portion for other 30 users)

	\$9,650.00
Add state tax	454.71
	<hr/>
Total Due and Owing:	<u>\$10,104.71</u>

Your Purchase Order No: \_\_\_\_\_

Please make check payable to: THE LANGE GROUP  
Our Vendor Number 111320

Payable Upon Receipt  
Thank You

We/I certify that this is your true and correct original invoice.

  
\_\_\_\_\_  
Nani Lindsey, Manager

5-23-2007  
\_\_\_\_\_  
Date

500764

**The Lange Group**  
1100 Ward Avenue, Suite 1050  
Honolulu, Hawaii 96814  
(808) 545-1822

May 23, 2007

Attn: Bob Masuda, Dep. Dir  
or Dennis Ihara, Dep. Admin.  
Bureau of Conveyances  
Department of Land & Natural Resources  
1151 Punchbowl Street, Room 122  
Honolulu, Hawaii 96813

**COPY**



Technical Support Maintenance for BCIS's APPX custom Imaging  
environment for the one year period: July 1, 2007 through June 30, 2008.

Sub-total \$ 31,200.00  
Add State Tax 1,470.14  
Total Due & Owing: \$ 32,670.14

*pd 9-11-07  
S0015984*

Your Purchase Order No: \_\_\_\_\_

Please make check payable to: THE LANGE GROUP  
Our vendor Number 111320

Payable upon receipt  
Thank You

500765

GOODS/SERVICES REC'D IN SATISFACTORY CONDITION DATE: 8/20/07		
Signature <i>[Signature]</i>		
	Init.	Date
Invoice Rec'd	<i>ew</i>	
OK to Pay		
Circle	PARTIAL FINAL	

**The Lange Group**  
1100 Ward Avenue, Suite 1050  
Honolulu, Hawaii 96814  
(808) 545-1822

May 17, 2006

Attn: Carl Watanabe, Registrar  
Bureau of Conveyances  
Department of Land & Natural Resources  
1151 Punchbowl Street, Room 122  
Honolulu, Hawaii 96813

**COPY**

Technical Support for BCIS's APPX custom Imaging environment  
for the one year period: July 1, 2006 through June 30, 2007.

Sub-total	\$ 31,200.00
Add State Tax	1,299.79
Total Due & Owing:	<u>\$ 32,499.79</u>

Please make check payable to: THE LANGE GROUP  
Our vendor Number 111320

Payable upon receipt  
Thank You

pd 8/19/06  
#5 0010407  
\$42,551.81

We/I certify that this is your true and correct original invoice.

  
\_\_\_\_\_  
Nani Lindsey, Manager

5-17-06  
\_\_\_\_\_  
Date

500766



**The Lange Group**  
1100 Ward Avenue, Suite 1050  
Honolulu, Hawaii 96814  
(808) 545-1822

May 15, 2007

Attn: Bob Masuda, Dep. Dir.  
Bureau of Conveyances  
Department of Land & Natural Resources  
1151 Punchbowl Street, Room 130  
Honolulu, Hawaii 96813

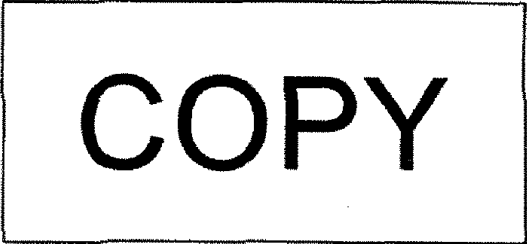

DLNR – Bureau of Conveyances: Consulting, Software and Programming Services to implement an emergency FTP “stop-gap” solution requested by the Attorney General and intended to be used for a temporary period of time to facilitate the downloading of data and images to DVD during which time the BCIS FTP-Server hardware was made unavailable to the General Public.

Sub-total	\$ 10,000.00
Add State Tax	450.00
Total Due & Owing:	<u>\$ 10,450.00</u>

Your Purchase Order No: \_\_\_\_\_

Please make check payable to: THE LANGE GROUP  
Our vendor Number 111320

Payable upon receipt  
Thank You

We/I certify that this is your true and correct original invoice.

\_\_\_\_\_  
Nani Lindsey, Manager

\_\_\_\_\_  
Date

500767

7-13-07  
5282 8/2/07  
Per Juliette  
will pay in next FY (July)

REVISED

**DLNR - Bureau of Conveyances  
Consulting, Software and Programming Services**

**LANGE**

**Statement of Work - FLAT FEE for Services**

The Lange Group ("TLG") will provide Consulting, Software Programming and Services, as deemed necessary and as described below in the Scope of Services, to assist the Department of Land and Natural Resources, Bureau of Conveyance ("BOC") in implementing a "stop-gap" solution intended to be used for a temporary period of time during which the BOC FTP-Server hardware, residing within the Bureau of Conveyances Information System ("BCIS"), is made unavailable to the General Public.

This contract authorized by you and specified below is a fixed-price contract. If it is determined that it is necessary to change the Scope of Services below or change the project end date, we will inform you as soon as practical. In such event, you may authorize the change in work or change the end date in writing. If you choose to extend our Services, you agree to pay us for actual hours expended and any actual cost or expenses (incurred by us and authorized by you) at our standard hourly rate. It is the responsibility of BOC to obtain the necessary approvals for TLG to conduct work outlined in the Scope of Services below.

**Scope of Services:**

TLG will provide consulting, programming, implementation and services to assist the Department of Land and Natural Resources, Data Processing Office ("DPO") with creation of electronic files residing on the BCIS, to hardware made available by DPO. These electronic files will contain digitized TIFF formatted images of documents recorded and scanned at the BOC, as well as index data entered into the BCIS by BOC. Such electronic files is intended to be burned on a DVD, for distribution to the General Public by the BOC. During the course of implementation, TLG will be allowed electronic access to the BCIS, as well as physical access to the BOC & DPO premises to accomplish their work. Programming services may consist of changes to the existing applications (not limited to programs, processes, end-user screens, reports, forms), where applicable, and restructuring and/or creation of electronic files, to provide electronic records (which can be downloaded to DVD) for distribution to the General Public, from the period April 13, 2007.

The following deliverables are to be provided:

- Electronic image files of recorded and scanned documents for the recording period 4/13/2007 – 4/18/2007
- Electronic image files of recorded and scanned documents for the recording period 4/19/2007 – 4/24/2007
- Electronic image files of recorded and scanned documents daily starting from recording date of 4/25/2007
- Electronic data files of recorded and indexed documents daily starting from recording date of 03/02/2007
- Computer Software programs to automate the daily creation of data and images by BOC or DPO so that they may be downloaded to DVD

**Completion Criteria:**

Services will end when 1) we provide the specified deliverables, or 2) the project end date.

Start Date: April 18, 2007  
End Date: May 18, 2007

**Services Charges:**

There will be a minimum charge for each day in which Services are provided at a standard hourly rate of \$250.00 per hour. Upon completion of the project, we will invoice you for all Service provided at the Flat Fee shown below. Actual cost or expenses will not incur unless approved by the Department of Land & Natural Resources, Bureau of Conveyances. Actual cost or expenses approved, will be invoiced separately.

**FLAT FEE Total Charges: \$10,450.00 (includes General Excise Tax)**

Each of us agrees that the complete agreement between us about these Services consists of 1) this Statement of Work and 2) if applicable, any equivalent agreement signed by both of us, or a Purchase Order reflecting the Scope of Services.

Provided by:  
Unique Computer Systems, Inc, dba  
The Lange Group

Agreed to:  
Department of Land & Natural Resources, Bureau of Conveyance

By   
Authorized signature  
Name NANI LINDSEY, Manager

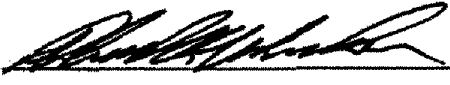
By   
Authorized signature  
Name ROBERT K. MASUDA, Dep. Dir. DLNR

Date: April 27, 2007

Date: April 27, 2007

500768

**The Lange Group**  
1100 Ward Avenue, Suite 1050  
Honolulu, Hawaii 96814  
(808) 545-1822

May 17, 2006

Attn: Carl Watanabe, Registrar  
Bureau of Conveyances  
Department of Land & Natural Resources  
1151 Punchbowl Street, Room 122  
Honolulu, Hawaii 96813

**COPY**



(SSS) APPX Software Support Services for the BCIS  
computer system IBM RS/6000 AIX, 64 users (max 94 users),  
for the one year period: July 1, 2006 through June 30, 2007.  
(Note: State Parks will pay pro-rata portion for other 30 users)

	\$9,650.00
Add state tax	402.02
	-----
Total Due and Owing:	<u>\$10,052.02</u>

*ad 8/19/06*  
*# S-0010407*  
*\$42,551.81*

Your Purchase Order No: \_\_\_\_\_

Please make check payable to: THE LANGE GROUP  
Our Vendor Number 111320

Thank You

We/I certify that this is your true and correct original invoice.

*NL* \_\_\_\_\_ 5-17-06  
Nani Lindsey, Manager Date

500769

**The Lange Group**  
1100 Ward Avenue, Suite 1050  
Honolulu, Hawaii 96814  
(808) 545-1822

November 28, 2005

Attn: Carl Watanabe, Registrar  
Bureau of Conveyances  
Department of Land & Natural Resources  
1151 Punchbowl Street, Room 122  
Honolulu, Hawaii 96813

COPY



Programming, implementation, and documentation services to assist the Bureau of Conveyances with the new report requested by Department of Budget & Finance regarding Conveyance Tax collections.

\$950.00

Add state tax

39.58

Total Due and Owing:

\$989.58

1-13-06

Reference Purchase Order: \_\_\_\_\_  
Please make check payable to: THE LANGE GROUP  
Our vendor Number 111320

Payable upon receipt  
Thank You

We/I certify that this is your true and correct original invoice.

  
\_\_\_\_\_  
Nani Lindsey, Manager

11-28-05  
\_\_\_\_\_  
Date

500770

**The Lange Group**  
1100 Ward Avenue, Suite 1050  
Honolulu, Hawaii 96814  
(808) 545-1822

August 22, 2005

Attn: Carl Watanabe, Registrar  
Bureau of Conveyances  
Department of Land & Natural Resources  
1151 Punchbowl Street, Room 122  
Honolulu, Hawaii 96813

**COPY**

Programming, implementation, and end-user training services to assist the Bureau of Conveyances with the modifications to the Appx Software system, electronic files and end-user daily procedures to effectuate the requirement of collecting the two-tier conveyance tax as outlined in HB 1308.

Total Due & Owing:

\$ 24,000.00

Reference Purchase Order: C20767  
Please make check payable to: THE LANGE GROUP  
Our vendor Number 111320

( Payable upon receipt  
( Thank You

We/I certify that this is your true and correct original invoice.

  
Nani Lindsey, Manager

8-22-2005  
Date

500771

*incl.  
8.1-05*

**Statement of Work - FLAT FEE for Services**

The Lange Group will provide Appx Software Programming and Implementation Services, as described below in the Scope of Services, to assist the Department of Land and Natural Resources, Bureau of Conveyances in implementing the HB1308 Conveyance Tax project. This contract authorized by you and specified below is a fixed-price contract. If it is determined that it is necessary to change the Scope of Services below or change the project end date, we will inform you as soon as practical. In such event, you may authorize the change in work or change the end date in writing. If you alternatively choose to terminate our Services, you agree to pay us for actual hours expended and any actual cost or expenses (incurred by us) through the termination of the project.

**Scope of Services:**

The Lange Group will provide programming, implementation and end-user training services to assist the Bureau of Conveyances with the modifications to the Appx Software system, electronic files and end-user daily procedures to effectuate the requirement of collecting the two-tier Conveyance Tax as outlined in HB1308, for the State of Hawaii, Bureau of Conveyances, under the HB1308 Conveyance Tax project.

Programming services will consist of changes to the existing Appx applications (not limited to programs, processes, end-user screens, reports, forms) known as (K03) LCATS, (K06) Receiving, and (K08) Abstracting, where applicable, and restructuring of existing electronic files, to work as expected per specifications to be determined by the DLNR-Bureau of Conveyances, DLNR-Fiscal Office, DLNR-Data Processing Office and the State of Hawaii Department of Taxation. The following deliverables are to be provided:

- Appx Program Modifications
- End User Training
- Acceptance Testing

We will attend pertinent meetings and help coordinate management of tasks of other State agencies and third party vendors, if any, through the representative designated by the Bureau of Conveyances.

**Completion Criteria:**

Services will end when 1) you advise us, in writing, that further Services are not required, or 2) we provide the specified deliverables, or 3) the project end date expires.

Start Date: June 13, 2005 (Notice to Proceed)  
Estimated End Date: September 13, 2005

**Services Charges:**

There will be a minimum charge for each day in which Services are provided at a rate of \$250.00 per hour. Upon completion of the project, we will invoice you for all Service provided not to exceed the Flat Fee shown below. Actual cost or expenses will not incur unless approved by the Bureau of Conveyances. Actual cost or expenses, if approved, will be invoiced separately.

**FLAT FEE Total Charges: \$24,000.00 (includes General Excise Tax)**

This offer will expire on September 13, 2005.

Each of us agrees that the complete agreement between us about these Services consists of 1) this Statement of Work and 2) if applicable, any equivalent agreement signed by both of us.

Provided by:  
Unique Computer Systems, Inc., dba  
The Lange Group

By *[Signature]*  
Authorized signature

Name (type or print): NANI LINDSEY, Manager

Date: June 14, 2005

Address: 1100 Ward Ave. Suite 1050  
Honolulu, HI 96814

Agreed to:  
Department of Land and Natural Resources  
Bureau of Conveyances

By *(x) [Signature]*  
Authorized signature

Name (type or print):  CARL WATANABE

Date:  7/22/05

Address: 1151 Punchbowl Street, Room 121  
Honolulu, HI 96813

500772

# STATE OF HAWAII REQUISITION & PURCHASE ORDER

**DEPARTMENT OF LAND AND NATURAL RESOURCES**

**CONVEYANCES**

ORGANIZATION

FUNCTION AND ACTIVITY

**NOTICE TO VENDORS**

Conditions of purchase are listed on the back side of this purchase order. Please read carefully. Payments may be delayed if all steps are not followed.

THE LANGE GROUP

1100 WARD AVENUE, SUITE 1050

HONOLULU, HI 96814

The State of Hawaii is an EQUAL EMPLOYMENT OPPORTUNITY and AFFIRMATIVE ACTION employer. We encourage the participation of women and minorities in all phases of employment.

**PURCHASE ORDER NO. C20767**

Date 072705

Deliver Before \_\_\_\_\_

**DELIVERY ADDRESS**

**BILLING ADDRESS**

*Met  
8-1-05*

QUAN.	UNIT	DESCRIPTION	OBJECT	UNIT PRICE	AMOUNT
		Programming, implementation, and end-user training services to assist the Bureau of Conveyances with the modifications to the AppX Software system, electronic files and end-user daily procedures to effectuate the requirement of collecting the two-tier conveyance tax as outlined in HB 1308.			\$24,000.00

*Carl Watanabe*  
**CARL WATANABE**

**587-0120**

REQUISITIONER

TELEPHONE

**VOUCHER NUMBER**

AUTHENTICATED BY: **JULIET KAZANJIAN**

*Juliet Kazanjian*  
AUTHORIZED SIGNATURE

GOODS/SERVICES RECEIVED IN GOOD ORDER AND CONDITION BY \_\_\_\_\_ DATE \_\_\_\_\_

REQUISITION NO.  
**00282741**

VENDOR	
NUMBER	SFX
XXXXXXXXXXXX	XX
111320	00

FOR DEPARTMENT USE ONLY

500773

SFX	TC	F	YR	APP	D	OBJECT	CC	PROJ NO.	PH	ACT	ESTIMATED COST	ACTUAL COST	M	R	OPT DEPT DATA	
XX	XXX	X	XX	XXX	XX	XXXX	XXXX	XXXXXXXX	XX	XXX	XXXXXXXXXXXX	XX	XXXXXXXXXXXX	XX	X	XXXXXXXXXXXX
01	621	S	06	309	C	5870	0210	000000	00	020	\$24,000					

**The Lange Group**  
1100 Ward Avenue, Suite 1050  
Honolulu, Hawaii 96814  
(808) 545-1822

June 9, 2005

Attn: Carl Watanabe, Registrar  
Bureau of Conveyances  
Department of Land & Natural Resources  
1151 Punchbowl Street, Room 122  
Honolulu, Hawaii 96813

**COPY**

**INVOICE # 506**

<sup>4</sup> / <sub>3</sub> qty FUJITSU Scanner Stoppers @ \$6.00 each	24.00
Add State Tax	1.00
Sub Total	<u>\$ 25.00</u>
Shipping	15.50
Total Due & Owing:	<u><u>\$ 40.50</u></u>

8/19/05  
5001258

Please make check payable to: THE LANGE GROUP

Our vendor Number 111320

Payable upon receipt

Thank You

We/I certify that this is your true and correct original invoice.

  
\_\_\_\_\_  
Nam Lindsey, Manager

6-9-2005  
\_\_\_\_\_  
Date

500774



**STATE OF HAWAII  
REQUISITION & PURCHASE ORDER**

ORDER NO. C20772

**DEPARTMENT OF LAND AND NATURAL RESOURCES**

**CONVEYANCES**

ORGANIZATION

FUNCTION AND ACTIVITY

**NOTICE TO VENDORS**

Conditions of purchase are listed on the back side of this purchase order. Please read carefully. Payments may be delayed if all steps are not followed.

Date 072805

Deliver Before \_\_\_\_\_

**DELIVERY ADDRESS**

**BILLING ADDRESS**

THE LANGE GROUP

1100 WARD AVENUE, SUITE 1050

HONOLULU, HAWAII 96814

The State of Hawaii is an EQUAL EMPLOYMENT OPPORTUNITY and AFFIRMATIVE ACTION employer. We encourage the participation of women and minorities in all phases of employment.

QUAN.	UNIT	DESCRIPTION	OBJECT	UNIT PRICE	AMOUNT
3		FUJITSU Scanner Stoppers		\$ 6.00	\$24.00
			TAX:		\$ 1.00
			SHIPPING:		\$15.50
			TOTAL:		\$40.50
*Vendor will not accept FHB credit card					

*Carly*  
CARL WATANABE

587-0120

REQUISITIONER

TELEPHONE

VOUCHER  
NUMBER

AUTHENTICATED BY:

JULIET KAZANJIAN

*Juliet Kazanjian*

AUTHORIZED SIGNATURE

GOODS/SERVICES RECEIVED IN GOOD ORDER AND CONDITION BY

DATE

REQUISITION NO.

00282740

FOR DEPARTMENT USE ONLY

VENDOR

NUMBER	SFX
XXXXXXXXXX	XX
111320	00

500775

SFX	TC	F	YR	APP	D	OBJECT	CC	PROJ NO.	PH	ACT	ESTIMATED COST	ACTUAL COST	M	R	OPT DEPT DATA	
XX	XXX	X	XX	XXX	XX	XXXX	XXXXX	XXXXXXXX	XX	XXX	XXXXXXXXXXXXXX	XX	XXXXXXXXXXXXXX	XX	XX	XXXXXXXXXXXXXX
01	621	S	06	309	C	3200	0210	000000	00020		\$40.50					

Providing a wide variety of Digital Video and Imaging technologies  
 DVD, RAID, Jukeboxes, Scanners, CD Publishing, & Imaging Software  
 Supporting partnerships and leading-edge technology the reseller channel.

922005

**OPTICAL LASER**  
*The Value-Added Distributor*

TOTAL NUMBER OF ITEMS: 4  
 SHIP VIA: FEDEX 2DAY AIR  
 PACKER: MARY DURAN

CONTAINER ID 753203677163  
 WEIGHT 1.10  
 NUMBER OF PIECES 4

CONTAINER ID: 753203677163

4 EA 1 CA04315-Y372 STOPPER FOR STACKER FOR M4099D SCANNER

SHIP TO	SHIPPED FROM	DATE SHIPPED	CUSTOMER PO REF	LOAD #
THE LANGE GROUP DEPT. OF LAND & NTRL.RES. 1100 WARD AVE./STE. 1050 HONOLULU, HI 96823	OPTICAL LASER 13472 MARLAY AVE FONTANA, CA 92337	06/02/05	596517	1
CUSTOMER CONTACT: SUZANNE FLETCHER				
			BRADFORD BARTOLO	ORDER TAKEN
				# OF BOXES

CUSTOMER PO

**OPTICAL LASER**  
*The Value-Added Distributor*

*Optical & Digital Distribution  
 Imaging, Storage, & DV Solutions*

**ORDER PACKING**

# OPTICAL LASER

The Value-Added Distributor

Optical & Digital Distribution  
Imaging, Storage, & DV Solutions

## ORDER PACKING

PAGE 1 of 1

CUSTOMER PO

SHIP TO	SHIPPED FROM	DATE SHIPPED	CUSTOMER PO REF	LOAD #		
THE LANGE GROUP DEPT. OF LAND & NTRL.RES. 1100 WARD AVE./STE. 1050 NANI LINDSEY HONOLULU, HI 96823	OPTICAL LASER 13472 MARLAY AVE FONTANA, CA 92337	06/02/05		596517		
				# OF BOXES		
				1		
			ORDER TAKER			
			BRADFORD BARTOLO			
CUSTOMER CONTACT: SUZANNE FLETCHER						
QTY SHIPPED	UM	ORDER LINE#	ITEM #	VENDOR ITEM #	UPC#	ITEM DESCRIPTION

4 EA 1

CA04315-Y372

STOPPER FOR STACKER

FOR M4099D SCANNER

CONTAINER ID: 753203677163

TOTAL NUMBER OF ITEMS: 4  
SHIP VIA: FEDEX 2DAY AIR  
PACKER: MARY DURAN

CONTAINER ID  
753203677163

WEIGHT  
1.10

NUMBER OF PIECES  
4

# OPTICAL LASER

The Value-Added Distributor

500777

Providing a wide variety of Digital Video and Imaging technologies  
DVD, RAID, Jukeboxes, Scanners, CD Publishing, & Imaging Software  
Supporting partnerships and leading-edge technology the reseller channel.

**OPTICAL LASER**  
The Value-Added Distributor

Optical & Digital Distribution  
Imaging, Storage, & DV Solutions

**ORDER PACKING**

PAGE 1 of 1

CUSTOMER PO

SHIP TO	SHIPPED FROM	DATE SHIPPED	CUSTOMER PO REF	LOAD #
THE LANGE GROUP DEPT. OF LAND & NTRL.RES. 1100 WARD AVE./STE. 1050 NANI LINDSEY HONOLULU, HI 96823	OPTICAL LASER 13472 MARLAY AVE FONTANA, CA 92337	06/02/05		596517
CUSTOMER CONTACT	ORDER LINE#	ORDER ITEM #	UPC#	VENDOR ITEM #
SUZANNE FLETCHER				
QTY SHIPPED	UM	EA	1	3

STOPPER FOR STACKER FOR M4099D SCANNER

CONTAINER ID: 753203677163

TOTAL NUMBER OF ITEMS: 4  
SHIP VIA: FEDEX 2DAY AIR  
PACKER: MARY DURAN

CONTAINER ID  
753203677163

WEIGHT  
1.10

NUMBER OF PIECES  
4

**OPTICAL LASER**  
The Value-Added Distributor

500778

Providing a wide variety of Digital Video and Imaging technologies  
DVD, RAID, Jukeboxes, Scanners, CD Publishing, & Imaging Software  
Supporting partnerships and leading-edge technology the reseller channel.

Nani Lindsey

BOC

From: <Evelyn.K.Ng@hawaii.gov>  
To: "Nani Lindsey" <nlindsey@compuserve.com>  
Cc: <Carl.T.Watanabe@hawaii.gov>  
Sent: Monday, May 02, 2005 1:41 PM  
Attach: Fujitsu Scanner.tif  
Subject: Re: San Jose

Scanners = 587-0156

Model: ~~4099D~~ 4099D?

90ppm

2 Kits Fujitsu Maint Contract:  
Tech Support DIV: (800) 626-4686

Hi Nani:

Attached is a diagram of the scanner unit. The part is #18 on the diagram. It's the Stop Lever that is used to keep documents in the stacker. If you could purchase at least 3 or 4 stop levers, BOC can reimburse you with an original receipt. The microphotographers were told that the part is about \$12 each. x 4 = \$48

"Nani Lindsey" <nlindsey@compuserve.com>

To <Carl.T.Watanabe@hawaii.gov>  
cc <Evelyn.K.Ng@hawaii.gov>

Subject Re: San Jose

05/02/2005 08:34 AM

Please respond to  
"Nani Lindsey" <nlindsey@compuserve.com>

Yes, soon...

Do you still have the old box or something I can see? The part# and description will do if you don't. I'll be there next week (returning 5/20 to Hawaii).

----- Original Message -----

From: Carl.T.Watanabe@hawaii.gov  
To: nlindsey@compuserve.com  
Cc: Evelyn.K.Ng@hawaii.gov  
Sent: Monday, May 02, 2005 8:11 AM  
Subject: San Jose

heart, 15-20 min drive, not Hwy, like Miami B more stop lights.  
= very big

Might you be in San Jose soon? Only asking. Our scanner needs a part that costs \$12 BUT shipping is \$25. Fujitsu has a supply facility in San Jose.

MS/IBM = road winds + turns  
Just checking. 10 blocks / huge parking lots - 1 block length  
Fujitsu = Industrial Area - Flat + Wide spread  
1-2-3 story buildings

Hon Blue - 531-4611 (Supplies) x 2  
Bret. Maint  
Chip Churchill  
Widget fixer to Sales.

(1) 5am - 5pm PST.

(2) www.fcpa.com

1-877-482-1990

- PART # CA04315-Y372 "stopper"  
- ORDER 4 ea @ \$12 ea = \$48 ea. BLAKE Contacts: Cust Svc 800-626-4686 > 1

- SHIP VIA FedEX TLG acct # Attn: Nani Lindsey  
to 1100 Ward Ave

5-3-05 + Chip @ Hon Blue

Sub Supplies to WHSE + SHIPPING - mid East Coast

5-3-05 + Blake 531-4611 x 531

ETA: Next week  
BD. PART will set ETA + low volume msg @ 5/3/05

500779

# Units and Assemblies

This section shows the exterior view and assemblies of the scanner. This section also provides names of each part and describes their functions.

## ■ Units

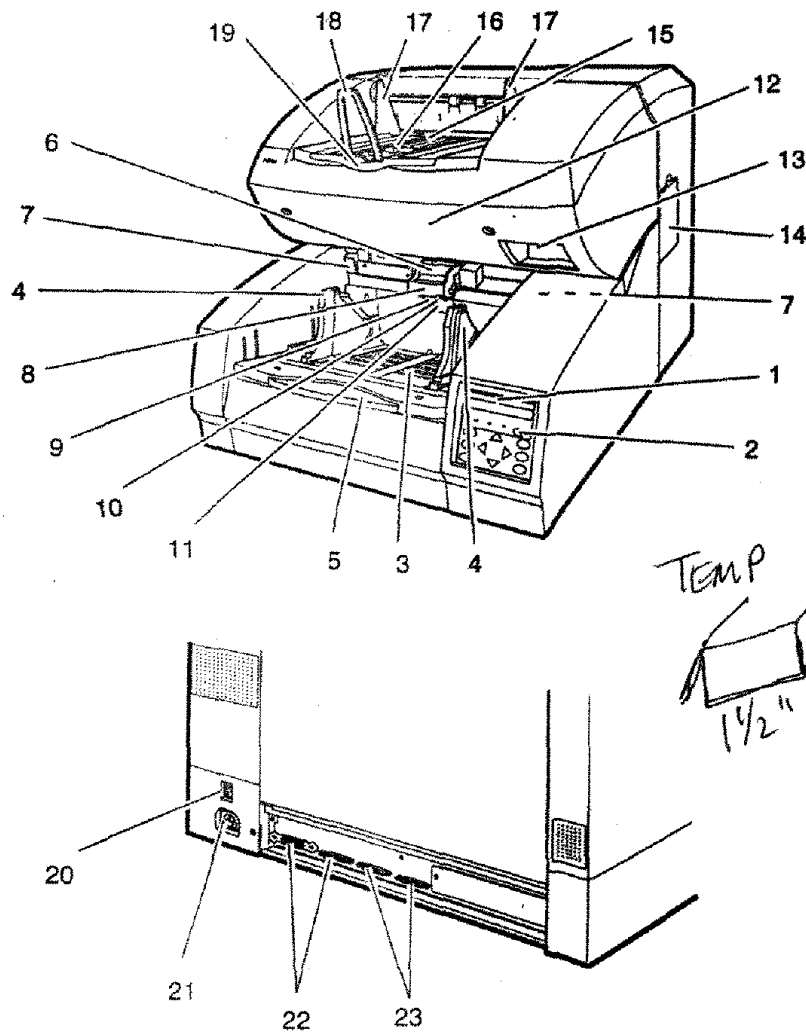

No.
1
2
3
4
5
6
7
8
9
10
11
12
13
14
15
16
17
18
19
20
21
22
23

500780

**The Lange Group**  
1100 Ward Avenue, Suite 1050  
Honolulu, Hawaii 96814  
(808) 545-1822

June 2, 2005

Attn: Carl Watanabe, Registrar  
Bureau of Conveyances  
Department of Land & Natural Resources  
1151 Punchbowl Street, Room 122  
Honolulu, Hawaii 96813

**COPY**



Technical Support for BCIS's APPX custom imaging environment  
for the one year period: July 1, 2005 through June 30, 2006

Sub-total	\$ 31,200.00
Add State Tax	1,299.79
Total Due & Owing:	<u>\$ 32,499.79</u>

Please make check payable to: THE LANGE GROUP  
Our vendor Number 111320

Payable upon receipt  
Thank You

*pd 9/30/05*

We/I certify that this is your true and correct original invoice.

*[Signature]*                      6-2-2005  
Nani Lindsey, Manager                      Date

500781

**The Lange Group**  
1100 Ward Avenue, Suite 1050  
Honolulu, Hawaii 96814  
(808) 545-1822

June 2, 2005

Attn: Carl Watanabe, Registrar  
Bureau of Conveyances  
Department of Land & Natural Resources  
1151 Punchbowl Street, Room 122  
Honolulu, Hawaii 96813

**COPY**



(SSS) APPX Software Support Services for the BCIS  
computer system IBM RS/6000 AIX, 64 users (max 94 users),  
for the one year period: July 1, 2005 through June 30, 2006.  
(Note: State Parks will pay pro-rata portion for other 30 users)

	\$9,216.00
Add state tax	383.94
	-----
Total Due and Owing:	<u>\$9,599.94</u>

*8/25/05*

Your Purchase Order No: \_\_\_\_\_

Please make check payable to: THE LANGE GROUP  
Our Vendor Number 111320

*INTEREST 46.28*  
*9-12-05*

Thank You

We/I certify that this is your true and correct original invoice.

*Nani Lindsey* 6-2-2005  
Nani Lindsey, Manager Date

500782



# STATE OF HAWAII REQUISITION & PURCHASE ORDER

**DEPARTMENT OF LAND AND NATURAL RESOURCES**

**CONVEYANCES**

ORGANIZATION

FUNCTION AND ACTIVITY

**NOTICE TO VENDORS**

Conditions of purchase are listed on the back side of this purchase order. Please read carefully. Payments may be delayed if all steps are not followed.

THE LANGE GROUP

1100 WARD AVENUE, SUITE 1050

HONOLULU, HAWAII 96814

The State of Hawaii is an EQUAL EMPLOYMENT OPPORTUNITY and AFFIRMATIVE ACTION employer. We encourage the participation of women and minorities in all phases of employment.

<b>PURCHASE ORDER NO.</b> C21088	
Date <u>081205</u>	
Deliver Before _____	
<b>DELIVERY ADDRESS</b>	
<i>mail 8-16-05</i>	
<b>BILLING ADDRESS</b>	

QUAN.	UNIT	DESCRIPTION	OBJECT	UNIT PRICE	AMOUNT
		(SSS) APPX Software Support Services for the BCIS computer system IBM RS/6000 AIX, 64 Users (max 94 users), for the one year period: July 1, 2005 through June 30, 2006			\$9,216.00
				State Tax:	\$ 383.94
				<b>TOTAL:</b>	<b>\$9,599.94</b>
Vendor does not accept FHB card					
		Carl Watanabe	587-0120	AUTHENTICATED BY: JULIET KAZANJIAN <i>Juliet Kazanjian</i> AUTHORIZED SIGNATURE	
REQUISITIONER		TELEPHONE		VOUCHER NUMBER	
GOODS/SERVICES RECEIVED IN GOOD ORDER AND CONDITION BY			DATE		

<b>REQUISITION NO.</b> <b>00282744</b>	<b>FOR DEPARTMENT USE ONLY</b>						
<b>VENDOR</b>	<b>500783</b>						
<table border="1" style="width: 100%; border-collapse: collapse;"> <tr> <th style="width: 10%;">NUMBER</th> <th style="width: 10%;">SFX</th> </tr> <tr> <td>XXXXXXXXXXXX</td> <td>XX</td> </tr> <tr> <td>111320</td> <td>00</td> </tr> </table>	NUMBER	SFX	XXXXXXXXXXXX	XX	111320	00	
NUMBER	SFX						
XXXXXXXXXXXX	XX						
111320	00						

SFX	TC	F	YR	APP	D	OBJECT	CC	PROJ NO.	PH	ACT	ESTIMATED COST	ACTUAL COST	M	R	OPT DEPT DATA
XX	XX	X	XX	XXX	XX	XXXX	XXXX	XXXXXXXX	XX	XX	XXXXXXXXXXXX	XX	XX	XX	XXXXXXXXXXXX
01	621	S	06	309	C	3200	0210	000000	00	020	\$9,599.94				

**The Lange Group**  
1100 Ward Avenue, Suite 1050  
Honolulu, Hawaii 96814  
(808) 545-1822

June 2, 2004

Attn: Carl Watanabe, Registrar  
Bureau of Conveyances  
Department of Land & Natural Resources  
1151 Punchbowl Street, Room 122  
Honolulu, Hawaii 96813

**COPY**



(SSS) APPX Software Support Services for the BCIS  
computer system IBM RS/6000 AIX, 64 users (max 94 users),  
for the one year period: July 1, 2004 through June 30, 2005.  
(Note: State Parks will pay pro-rata portion for 30 users)

	\$9,216.00
Add state tax	383.94
	-----
Total Due and Owing:	<u>\$9,599.94</u>

*6-18-04  
Paid PO.  
7-13-04  
3-0001529*

Your Purchase Order No: C15378

Please make check payable to: THE LANGE GROUP  
Our Vendor Number 111320

Thank You

We/I certify that this is your true and correct original invoice.

\_\_\_\_\_  
Nani Lindsey, Manager

\_\_\_\_\_  
Date

500784

# STATE OF HAWAII REQUISITION & PURCHASE ORDER

**DEPARTMENT OF LAND AND NATURAL RESOURCES**  
ORGANIZATION

**CONVEYANCES**  
FUNCTION AND ACTIVITY

**NOTICE TO VENDORS**

Conditions of purchase are listed on the back side of this purchase order. Please read carefully. Payments may be delayed if all steps are not followed.

The Lange Group

1100 Ward Avenue, Suite 1050

Honolulu, HI 96814

The State of Hawaii is an EQUAL EMPLOYMENT OPPORTUNITY and AFFIRMATIVE ACTION employer. We encourage the participation of women and minorities in all phases of employment.

PURCHASE ORDER NO. **C15378**

Date **061604**  
Deliver Before \_\_\_\_\_

**DELIVERY ADDRESS**

**BILLING ADDRESS**

*ml  
6-18-04*

QUAN.	UNIT	DESCRIPTION	OBJECT	UNIT PRICE	AMOUNT
		Technical support services for (SSS) APPX software for the BCIS computer system for the period 7/1/04 to 6/30/05 and license fees. for 64 users (max 94 users). (Note: State Parks will pay pro-rata portion for 30 users)			\$9,599.94

Carl Watanabe  
*[Signature]*  
REQUISITIONER

587-0120  
TELEPHONE

VOUCHER NUMBER

AUTHENTICATED BY: Juliet Kazanjian

*[Signature]*  
AUTHORIZED SIGNATURE

GOODS/SERVICES RECEIVED IN GOOD ORDER AND CONDITION BY \_\_\_\_\_ DATE \_\_\_\_\_

REQUISITION NO.	
<b>00270598</b>	
VENDOR	
NUMBER	SFX
XXXXXXXXXXXX	XX
111320	00 <input checked="" type="checkbox"/>

FOR DEPARTMENT USE ONLY

500785

SFX	TC	F	YR	APP	D	OBJECT	CC	PROJ NO.	PH	ACT	ESTIMATED COST		ACTUAL COST		M	R	OPT DEPT DATA
XX	XXX	X	XX	XXX	XX	XXXX	XXXX	XXXXXXXXXX	XX	XXX	XXXXXXXXXXXXXX	XX	XXXXXXXXXXXXXX	XX	X	X	XXXXXXXXXXXXXX
01	621	S	04	309	C	5870	0210	000000	00	020	9,599	94					

**The Lange Group**  
1100 Ward Avenue, Suite 1050  
Honolulu, Hawaii 96814  
(808) 545-1822

June 2, 2004

Attn: Carl Watanabe, Registrar  
Bureau of Conveyances  
Department of Land & Natural Resources  
1151 Punchbowl Street, Room 122  
Honolulu, Hawaii 96813

**COPY**

**INVOICE # 3025**

Technical Support for BCIS's APPX custom imaging environment  
for the one year period: July 1, 2004 through June 30, 2005

Sub-total	\$ 31,200.00
Add State Tax	1,299.79
Total Due & Owing:	<u>\$ 32,499.79</u>

9-10-04

Please make check payable to: THE LANGE GROUP  
Our vendor Number 111320

Payable upon receipt  
Thank You

We/I certify that this is your true and correct original invoice.

 6/2/04  
Nani Lindsey, Manager Date

500786



LINDA LINGLE  
GOVERNOR OF HAWAII



CARL T. WATANABE  
REGISTRAR OF CONVEYANCES

TELEPHONE (808) 587-0120

FAX (808) 587-0138

STATE OF HAWAII  
DEPARTMENT OF LAND AND NATURAL RESOURCES  
BUREAU OF CONVEYANCES

P. O. BOX 2867

HONOLULU HAWAII 96803

September 8, 2003

Ms. Nani Lindsey  
The Lange Group  
1100 Ward Avenue, Suite 1050  
Honolulu, Hawaii 96814

Re: ICS-FY-99-52

Dear Ms. Lindsey:

This is to confirm our understanding of changes in the current contract to delete Task 11, relating to a GIS Requirement Study and substituting in its place Content Manager enhancement and maintenance. Funding for this change will be covered by the current quote submitted and approved as part of the above referenced contract.

Please acknowledge your agreement to this change. Should you have any questions, please feel free to contact me.

Very truly yours,

  
Carl T. Watanabe  
Registrar

*- Bill CM - \$32,009.79  
- about \$400 left in cont.  
per Gwdgn: \$35,969.80  
- need tax clearance  
- pay Mike, \$  
- pay Alan 4 hrs @ 250 = 10x*

Approved and accepted:

The Lange Group

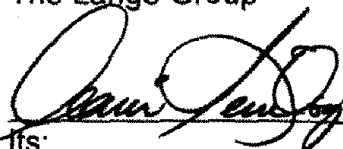
  
\_\_\_\_\_  
Its:

Date: 9-8-2003

500788

**The Lange Group**  
1100 Ward Avenue, Suite 1050  
Honolulu, Hawaii 96814  
(808) 545-1822

January 17, 2003

Attn: Carl Watanabe, Deputy Registrar  
Bureau of Conveyances  
Department of Land & Natural Resources  
1151 Punchbowl Street, Room 122  
Honolulu, Hawaii 96813

**COPY**

Semi-annual Technical Support Service for the BCIS custom  
Imaging environment consisting of IBM Content Manager and  
Visual Basic applications for the half year period:  
January 1, 2003 through June 30, 2003

Based on a total estimated hours of 104 hours @ \$150.00 per hour

FLAT Fee Cost:	\$ 15,600.00
Add State Tax	649.90
Total Due & Owing:	<u>\$ 16,249.90</u>

Reference Purchase Order: \_\_\_\_\_

Please make check payable to: **THE LANGE GROUP**  
Our vendor Number 111320

Payable upon receipt  
Thank You

We/I certify that this is your true and correct original invoice.

  
\_\_\_\_\_  
Nani Lindsey, Manager

1-17-03  
\_\_\_\_\_  
Date

500789

**The Lange Group**  
1100 Ward Avenue, Suite 1050  
Honolulu, Hawaii 96814  
(808) 545-1822

August 5, 2003

Attn: Carl Watanabe, Registrar  
Bureau of Conveyances  
Department of Land & Natural Resources  
1151 Punchbowl Street, Room 122  
Honolulu, Hawaii 96813

**COPY**

PAYMENT MILESTONE in reference to ICS-FY-99-52 and  
Contract #46621, the following items have been completed:

Task 3 – Replacement of R/S & L/C For completion of Enhancements	13,801.99
Task 8 – Enable Public Access to Text Data For completion of Training	53,175.72

Total Due & Owing:

\$ 66,977.71

9-4-03

*[Signature]*

Please make check payable to: **THE LANGE GROUP**  
Our vendor Number 111320  
Payable upon receipt  
Thank You

We/I certify that this is your true and correct original invoice.

*[Signature]*  
\_\_\_\_\_  
Nani Lindsey, Manager

8-5-03  
\_\_\_\_\_  
Date

500790



**The Lange Group**  
1100 Ward Avenue, Suite 1050  
Honolulu, Hawaii 96814  
(808) 545-1822

June 19, 2003

Attn: Carl Watanabe, Registrar  
Bureau of Conveyances  
Department of Land & Natural Resources  
1151 Punchbowl Street, Room 122  
Honolulu, Hawaii 96813

**COPY**



PAYMENT MILESTONE in reference to ICS-FY-99-52 and Contract #46621, the following items have been completed:

Task 8 – Enable Public Access to Text Data  
For completion of System Specifications

53,175.71

Total Due & Owing:

\$ 53,175.71

*pd 7-25-03  
ch # 5269  
\$ 142,985.57*

Please make check payable to: THE LANGE GROUP  
Our vendor Number 111320  
Payable upon receipt  
Thank You

We/I certify that this is your true and correct original invoice.

  
\_\_\_\_\_  
Nari Lindsey, Manager

*6-19-03*  
\_\_\_\_\_  
Date

500791

**The Lange Group**  
1100 Ward Avenue, Suite 1050  
Honolulu, Hawaii 96814  
(808) 545-1822

May 30, 2003

Attn: Carl Watanabe, Registrar  
Bureau of Conveyances  
Department of Land & Natural Resources  
1151 Punchbowl Street, Room 122  
Honolulu, Hawaii 96813

**COPY**



PAYMENT MILESTONE in reference to ICS-FY-99-52 and Contract #46621, the following items have been completed:

Task 2 – BCIS Requirements Verification For final delivery of Requirements Specifications	48,458.02
Task 9 – Enable Public Access to Image Data For completion of Acceptance Test & Training	41,351.84

Total Due & Owing:

**\$ 89,809.86**

Please make check payable to: THE LANGE GROUP  
Our vendor Number 111320  
Payable upon receipt  
Thank You

*rd 7-25-03  
ck # 5269  
# 142,985.57*

We/I certify that this is your true and correct original invoice.

  
\_\_\_\_\_  
Nani Lindsey, Manager

*5-30-03*  
\_\_\_\_\_  
Date

500792

**The Lange Group**  
1100 Ward Avenue, Suite 1050  
Honolulu, Hawaii 96814  
(808) 545-1822

May 25, 2003

Attn: Carl Watanabe, Deputy Registrar  
Bureau of Conveyances  
Department of Land & Natural Resources  
1151 Punchbowl Street, Room 122  
Honolulu, Hawaii 96813

**COPY**



4/8  
3003

Annual Technical Support Service for the BCIS custom  
APPX environment consisting of K03 LCATS, K06 Receiving  
and K08 Abstracting applications for the one year period:  
July 1, 2003 through June 30, 2004

Annual TSS Cost:	\$ 15,000.00
Add State Tax	624.90
Total Due & Owing:	<u><u>\$ 15,624.90</u></u>

Reference Contract: RFP-ICS-FY-99-052

Please make check payable to: **THE LANGE GROUP**  
Our vendor Number 111320

Payable upon receipt  
Thank You

We/I certify that this is your true and correct original invoice.

\_\_\_\_\_  
Nani Lindsey, Manager

\_\_\_\_\_  
Date

**500793**

# STATE OF HAWAII REQUISITION & PURCHASE ORDER

**DEPARTMENT OF LAND AND NATURAL RESOURCES**  
ORGANIZATION

**CONVEYANCES**  
FUNCTION AND ACTIVITY

**NOTICE TO VENDORS**

Conditions of purchase are listed on the back side of this purchase order. Please read carefully. Payments may be delayed if all steps are not followed.

The Lange Group

1100 Ward Avenue, Suite 1050

Honolulu, HI 96814

Tel. 545-1822

The State of Hawaii is an EQUAL EMPLOYMENT OPPORTUNITY and AFFIRMATIVE ACTION employer. We encourage the participation of women and minorities in all phases of employment.

**PURCHASE ORDER NO. C02971**

Date 090203

Deliver Before \_\_\_\_\_

**DELIVERY ADDRESS**

**BUREAU OF CONVEYANCES**  
1151 PUNCHBOWL STREET  
HONOLULU, HAWAII 96813

**BILLING ADDRESS**

**BUREAU OF CONVEYANCES**  
P.O. BOX 2867  
HONOLULU, HAWAII 96803

QUAN.	UNIT	DESCRIPTION	UNIT PRICE	AMOUNT
		Invoice No. 3002		
		Technical support services for BCIS custom APPX environment for the period 7/1/03 to 6/30/04.		\$15,000.00
		Tax		624.90
		Total		\$15,624.90

Carl Watanabe



REQUISITIONER

587-0120

TELEPHONE

**VOUCHER NUMBER**

AUTHENTICATED BY: Dennis Takahashi



AUTHORIZED SIGNATURE

GOODS/SERVICES RECEIVED IN GOOD ORDER AND CONDITION BY \_\_\_\_\_

DATE \_\_\_\_\_

REQUISITION NO.  
**00262182**

VENDOR

NUMBER	SFX
XXXXXXXXXXXX	XX
111320	00 <input checked="" type="checkbox"/>

FOR DEPARTMENT USE ONLY

500794

SFX	TC	F	YR	APP	D	OBJECT	CC	PROJ NO.	PH	ACT	ESTIMATED COST	ACTUAL COST	M	R	OPT DEPT DATA
XX	XXX	X	XX	XXX	XX	XXXX	XXXX	XXXXXXXX	XX	XXX	XXXXXXXXXXXX	XX	XXXX	XX	XXXX
01	621	S	03	309	C	5870	0210	00000000	020		15,624.90				

**The Lange Group**  
1100 Ward Avenue, Suite 1050  
Honolulu, Hawaii 96814  
(808) 545-1822

May 25, 2003

Attn: Carl Watanabe, Registrar  
Bureau of Conveyances  
Department of Land & Natural Resources  
1151 Punchbowl Street, Room 122  
Honolulu, Hawaii 96813

**COPY**



(SSS) APPX Software Support Services for the BCIS  
computer system IBM RS/6000 AIX, 60 users,  
for the one year period: July 1, 2003 through June 30, 2004.  
(Note: includes 10 user increase in license fees 50 to 60 users)

	\$9,216.00
Add state tax	383.94
Total Due and Owing:	<u>\$9,599.94</u>

8/25/03

Your Purchase Order No: \_\_\_\_\_

Please make check payable to: **THE LANGE GROUP**  
Our Vendor Number 111320

Thank You

We/I certify that this is your true and correct original invoice.

\_\_\_\_\_  
Nani Lindsey, Manager

\_\_\_\_\_  
Date

500795

# STATE OF HAWAII REQUISITION & PURCHASE ORDER

**DEPARTMENT OF LAND AND NATURAL RESOURCES**

**CONVEYANCES**

ORGANIZATION

FUNCTION AND ACTIVITY

**NOTICE TO VENDORS**

Conditions of purchase are listed on the back side of this purchase order. Please read carefully. Payments may be delayed if all steps are not followed.

The Lange Group

1100 Ward Avenue, Suite 1050

Honolulu, HI 96814

Tel. 545-1822

The State of Hawaii is an EQUAL EMPLOYMENT OPPORTUNITY and AFFIRMATIVE ACTION employer. We encourage the participation of women and minorities in all phases of employment.

PURCHASE ORDER NO. **C01071**

Date **071803**

Deliver Before \_\_\_\_\_

**DELIVERY ADDRESS**

**BUREAU OF CONVEYANCES  
1151 PUNCHBOWL STREET  
HONOLULU, HAWAII 96813**

**BILLING ADDRESS**

**BUREAU OF CONVEYANCES  
P.O. BOX 2867  
HONOLULU, HAWAII 96803**

QUAN.	UNIT	DESCRIPTION	UNIT PRICE	AMOUNT
		Invoice No. 2993		
		Technical support services for (SSS) APPX software for the BCIS computer system for the period 7/1/03 to 6/30/04 and license fees for 60 users.		\$9,216.00
		Tax		383.94
		Total		\$9,599.94

Carl Watanabe

REQUISITIONER

587-0120  
TELEPHONE

VOUCHER NUMBER

AUTHENTICATED BY: Karen Matsunaga

*[Signature]*  
AUTHORIZED SIGNATURE

GOODS/SERVICES RECEIVED IN GOOD ORDER AND CONDITION BY \_\_\_\_\_ DATE \_\_\_\_\_

FOR DEPARTMENT USE ONLY

REQUISITION NO.

**00262141**

VENDOR

NUMBER	SFX
XXXXXXXXXX	XX
111320	00

**500796**

SFX	TC	F	YR	APP	D	OBJECT	CC	PROJ NO.	PH	ACT	ESTIMATED COST	ACTUAL COST	M	R	OPT DEPT DATA
XX	XXX	X	XX	XXX	XX	XXXX	XXXX	XXXXXXXX	XX	XXX	XXXXXXXXXXXXXX	XX	XXXX	XX	XXXX
01	621	S	04	309	C	5870	0210	00000000	020		9,599.94				

**The Lange Group**  
1100 Ward Avenue, Suite 1050  
Honolulu, Hawaii 96814  
(808) 545-1822

March 6, 2003

Attn: Carl Watanabe, Deputy Registrar  
Bureau of Conveyances  
Department of Land & Natural Resources  
1151 Punchbowl Street, Room 122  
Honolulu, Hawaii 96813

**COPY**



PAYMENT MILESTONE in reference to ICS-FY-99-52 and  
Contract #46621, the following items have been completed:

Task 8 – Enable Public Access to Text Data For Delivery of Attachment H Components	33,121.12
Task 9 – Enable Public Access to Images FTP For Completion of System Specifications	20,675.92

Total Due & Owing:

\$ 53,797.04

4-8-03

Please make check payable to: THE LANGE GROUP  
Our vendor Number 111320  
Payable upon receipt  
Thank You

We/I certify that this is your true and correct original invoice.

  
\_\_\_\_\_  
Nani Lindsey, Manager

3-6-03  
\_\_\_\_\_  
Date

500797