

APPLYING RFID TECHNOLOGY IN NUCLEAR MATERIALS MANAGEMENT

Hanchung Tsai, Kun Chen, Yung Liu, J.P. Norair,¹ Steve Bellamy,² and Jim Shuler³

Argonne National Laboratory
Argonne, IL 60439

¹Savi Technology
Mountain View, CA 94041

²Savannah River National Laboratory
Aiken, SC 29808

³Department of Energy
Washington D.C. 20585

ABSTRACT

The Packaging Certification Program (PCP) of U.S. Department of Energy (DOE) Environmental Management (EM), Office of Safety Management and Operations (EM-60), has developed a Radio Frequency Identification (RFID) system for nuclear materials management. Argonne National Laboratory, a PCP supporting laboratory, and Savi Technology, a Lockheed Martin Company, are collaborating in the development of the RFID system, a process that involves hardware modification (form factor, seal sensor, and batteries), software development, and irradiation experiments. Savannah River National Laboratory and Argonne will soon field test the active RFID system on Model 9975 drums, which are used for storage and transportation of fissile and radioactive materials. Potential benefits of the RFID system are enhanced safety and security, reduced need for manned surveillance, real-time access of status and history data, and overall cost-effectiveness.

INTRODUCTION

Radio Frequency Identification (RFID) technology¹⁻⁴ is one of the most rapidly growing segments of today's automatic data collection industry. Examples of pervasive RFID applications are traffic toll collection, access control, cargo container monitoring for the military, and inventory control in the pharmaceutical industries. Passive RFID tags, which do not contain an onboard power supply or environmental sensor capabilities, are often used to replace barcode labels in retail, pharmaceutical, and military environments. Active RFID tags are distinct from passive RFID tags as they are equipped with an onboard power supply as well as sensors for monitoring environmental conditions and other critical parameters, such as the status of seals and object movement. Potential benefits of the application of active RFID tags in nuclear materials management are enhanced safety and security, reduced need for manned surveillance, real-time access of status and history data, and overall cost-effectiveness. Potential limitations of the RFID tags are inadequate resistance to radiation and battery life under service conditions that include storage and transportation of radioactive materials containers, such as the Model 9975 packagings. Thousands of the Model 9975 packagings have been certified by the U.S. Department of Energy for shipment of Type B radioactive and fissile materials in accordance with Part 71, Title 10 Code of Federal Regulations on *Packaging and Transportation of Radioactive Material*. Thousands of the Model 9975 packagings are currently used for interim storage of plutonium-bearing materials in specifically designed 3013 cans.⁵

In 2006, the Packaging Certification Program (PCP) of EM-60 initiated a project to evaluate the potential application of the RFID technology as part of a long-term strategy in the life-cycle management of radioactive materials packaging.⁶⁻⁷ A small number of high-performance, commercial RFID tags (ST-676)⁸ were obtained from Savi Technology. These tags were irradiated at Argonne National Laboratory and continuously monitored for performance over a period of three months. The surprisingly robust

results of the tags led to discussions between Argonne (on behalf of PCP) and Savi that culminated in a collaboration on the development of a prototype RFID system, an effort that involved both hardware modification and software development. Highlights of this effort are given in the remaining sections of this paper, along with a plan for field testing and future activities.

GAMMA IRRADIATION TESTING

The Savi ST-676 tag, shown in Fig. 1(a), has a form factor custom designed for the ISO container door application and is already widely used in military and commercial transport. Its operating frequency, 433.9 MHz, is known to be effective around metallic objects and offers good nonlinear communication. The standard sensor suite includes temperature, humidity, shock, light, and seal. A RS-485 port allows room for expansion to include other sensors, if warranted. The tag is equipped with two sizable nonvolatile read-write memory banks – 128 kB for user data and 32 kB for sensor logs. The tag uses one A-size, Li-SOCl₂ primary battery, which has high energy density and low self-drainage. Typical battery life is 3-4 years, depending on usage.

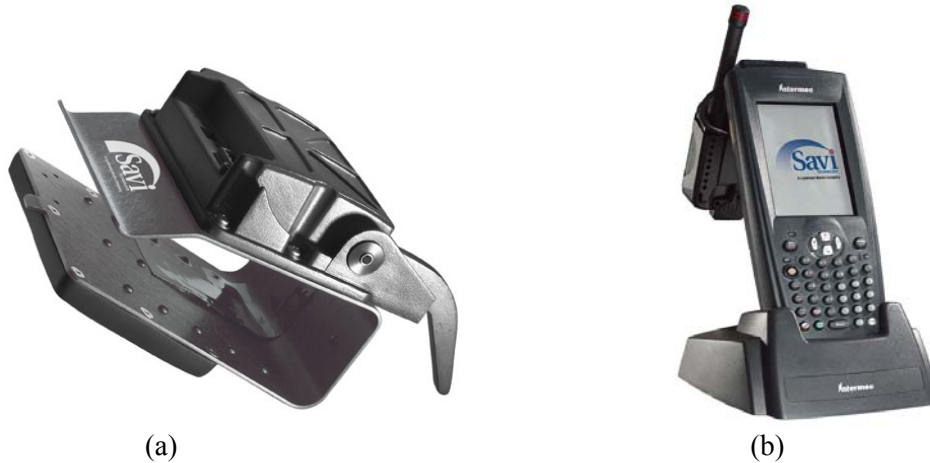

Figure 1. The Savi ST-676 tag, (a), and a hand-held mobile reader. (b)

The Savi hand-held mobile reader mounted on the Intermec® 751G/A mobile computer, shown in Fig. 1(b), has installed software for communication with the ST-676 tags and a computer. Four ST-676 tags were irradiated by a calibrated 20-Ci ¹³⁷Cs source (662 keV gamma) in a shielded vault, and were continuously monitored by the reader via the RF link. The metrics used to gauge the tag performance during the irradiation were the RF link, sensor response, and integrity of the stored user file. The size of the stored user file was such that nearly all of the 128-kB memory addresses were occupied. With these three periodic actions and responses, all crucial components in the tags were checked for radiation degradation. The irradiation lasted 3 months (October to December 2006) and reached a peak dose of 35.6 kiloroentgens (kR).

The endurance irradiation test results showed that, below 31 kR, all tags performed normally, while above 31 kR, two of the tags began to exhibit incipient RF difficulties. In a field of 200 mR/hr, which is the regulatory dose rate limit on the surface of a Type B packaging, 31 kR would correspond to a service life of >17 years. As most storage or transportation venues have significantly lower radiation background, the serviceable life of the tags would be proportionally longer. On the basis of this finding, it was concluded that the selected platform is suitable for further development.

During the gamma irradiation, the Li-SOCl₂ batteries were exposed to the same dose field as the tags' electronic boards and antenna. No safety or performance issues were encountered during the 3-month irradiation.

PROTOTYPE TAG DESIGN AND PRODUCTION

The guidelines adopted for the prototype tag design were as follows: (1) retain as much as possible of the electronic core of the stock ST-676 tags to minimize developmental costs, and (2) make the form factor universal such that the tags can be adopted for different packaging types. The reference packaging selected for the tag development and demonstration is the Model 9975 packaging,⁹ which is a 35-gallon drum with a bolted closure lid.

The original seal sensor of the ST-676 tag is designed for the door of a cargo container, not for drums with a bolted closure lid. A new seal sensor that would work with the drum bolts, therefore, was needed for the prototype tags. The resultant seal-sensor design is shown in Fig. 2.

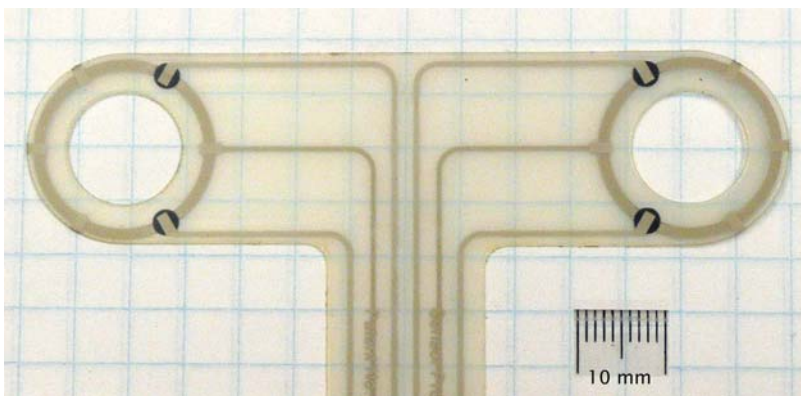

Figure 2. Seal sensor for the prototype tags. The four dark patches are the force-sensitive elements, and the two large openings are for the drum bolts. The electric leads above and below the elements relay the state of compression ($k\Omega$ when compressed and $M\Omega$ when not) to the tag electronics. The substrate is flexible plastic sheeting, and the assembly is protected by a plastic overlay. This design is for two adjacent bolts on a Model 9975 drum (see Fig. 3).

The sensor uses a force-sensitive material (with steep changes in resistivity) to monitor the bolt tension: under compression, the sensor's electric resistance is in the $k\Omega$ range; when the bolt tension is reduced, the resistance increases instantaneously to the $M\Omega$ range. With the threshold level of this sensor at $\approx 0.5 M\Omega$, alarms could be triggered even if the bolt is barely loosened. The force-sensitive material is silk-screen printable on a flexible plastic membrane, rendering it a relatively low-cost production. The method also allows ready modifications for different configurations and packagings. As the new seal sensor has no active components, its operation exerts essentially no load on the battery.

To reduce the likelihood of unintentional bumping and impact during handling of drums, the prototype tags are designed to have a slim profile that fits within the footprint of the 9975 drum cover. Figure 3 shows the front and back view of the tag. The front cover is made with ABS plastic by rapid-prototyping; the back cover is made with a sheet metal to provide structural rigidity. Injection molding is likely to be the manufacturing route for a large volume production of tags.

Up to four A-size Li-SOCl₂ batteries may be installed in the tag. The parallel batteries are managed by means of a smart switching circuit – only one battery is activated at any time to preclude leakage loops between batteries. As the self-drain of the Li-SOCl₂ battery is miniscule, multiple batteries can effectively extend the service period between battery changes. As will be discussed later, the condition of low-battery status will trigger a warning for the operator to take action. Because the tag memory is nonvolatile, a low-battery state will not result in a loss of data.

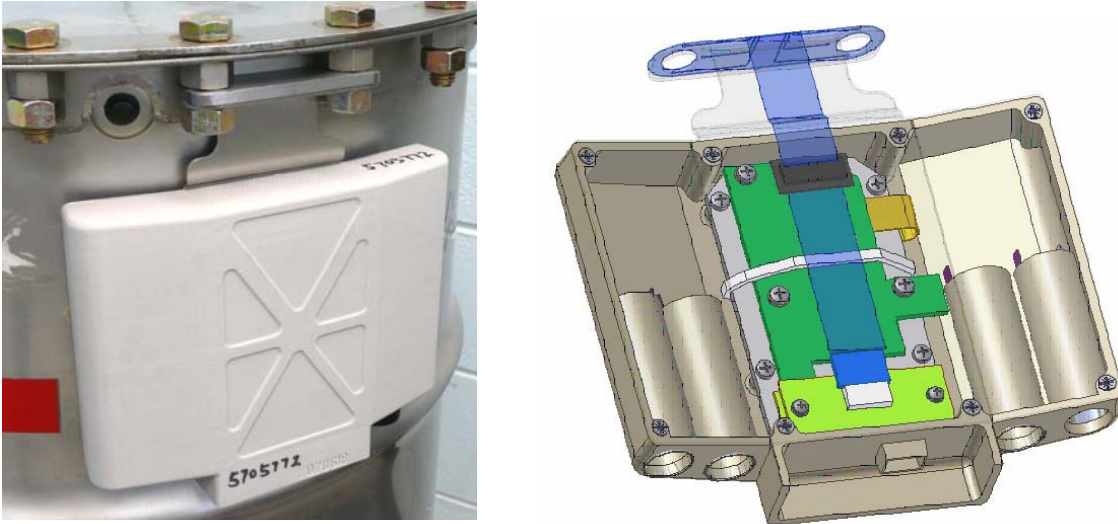

Figure 3. Left: A prototype tag mounted on a Model 9975 drum. Right: Interior view of the tag with the metal back plate removed. When mounted, the seal sensor and its ribbon cable are concealed behind the back plate. There is a provision for four batteries to extend the service life of the tag with a smart switching circuit.

The prototype tags retain the original temperature, humidity, and shock sensors of the ST-676s. By a judicious selection of the trip points, these sensors can provide valuable data to the surveillance effort during all operational phases of nuclear materials management. For instance, the shock sensor threshold may be set high for the drum transport, but it can be reset for the storage to alert even the slightest movement. Because all sensor actions are recorded, a life-long history is automatically created for every drum and is instantly retrievable by the operator. A compact radiation dosimeter sensor is under development.

By including a back plate with the proper top flange configuration, the prototype tag may be used for different types of drums without changing the electronic core. Figure 4 shows a conceptual view of the prototype tag mounted on an ES-3100 drum. A seal sensor of slightly different configuration would be required, but such a modification is straightforward for the silk-screen production process. In this manner, the cost for development of tags for different packagings could be held to a minimum.

The prototype tag measures about 120 mm (height) x 180 mm (width) x 25 mm (diameter) and weighs ≈ 700 g. The estimated production cost per tag is on the order of $\leq \$200$ USD.

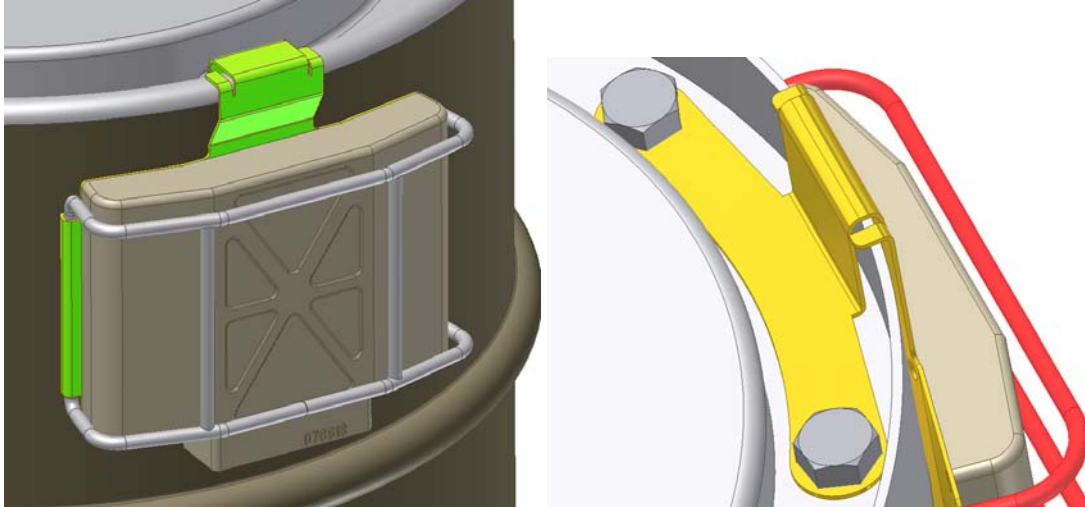

Figure 4. Conceptual mounting of a prototype RFID tag on ES-3100 packaging. Similar variations can be adopted for other drum types. Parts to be modified are the sheet-metal back plate and the seal sensor; the electronic core is retained.

PROTOTYPE APPLICATION SOFTWARE DEVELOPMENT

The application software on a desktop or handheld computer is the central part of the RFID system. The computer software receives signals from the readers and the tags, filters the data for duplicate or erroneous reads, applies rules-based business logic, and presents the data to the user in an easy-to-understand way. The user is also able to control and program the readers and the tags by sending commands to them through the software. For example, the software can allow the user to change sensor thresholds on a tag or to modify beaconing rates. The software can also store the information in a database for archiving or sharing the information with remote users through a secure network. Once set up, the software can work with the readers and the tags autonomously, requiring no human intervention.

The prototype application software consists of three key components: the Graphical User Interface, the feature set, and the underlying software architecture.

Graphical User Interface (GUI)

The user-friendly GUI is a critical part of the application software. The design philosophy is to present all relevant information in an intuitive way on the console screen so that the user can take immediate actions based on the information presented. The user should be able to retrieve all pertinent information easily by instructions provided with a few mouse clicks. A well-designed GUI can significantly reduce the learning curve of a user and ease the operation, thus increasing his/her efficiency and productivity. A sample GUI screen for drum storage is shown in Figure 5. Several thousand drums can be monitored in this manner.

The screen shown in Fig. 5 has six panes. The top-right pane is an overview of the entire domain, viewed from the top. The user can click on a specific region in that pane to zoom in and, when a drum status becomes abnormal, the symbol turns to yellow (warning) or flashing red (alarm). As the drums may be stacked in storage, the user can select and view the stacked drums in the side-view pane on the right of the screen. By clicking on a drum, the detailed information of the drum, including its environmental conditions and battery status, is displayed in a pop-up window. At the bottom of the GUI screen, from left to right, are the current status pane, the history event pane, and the search pane.

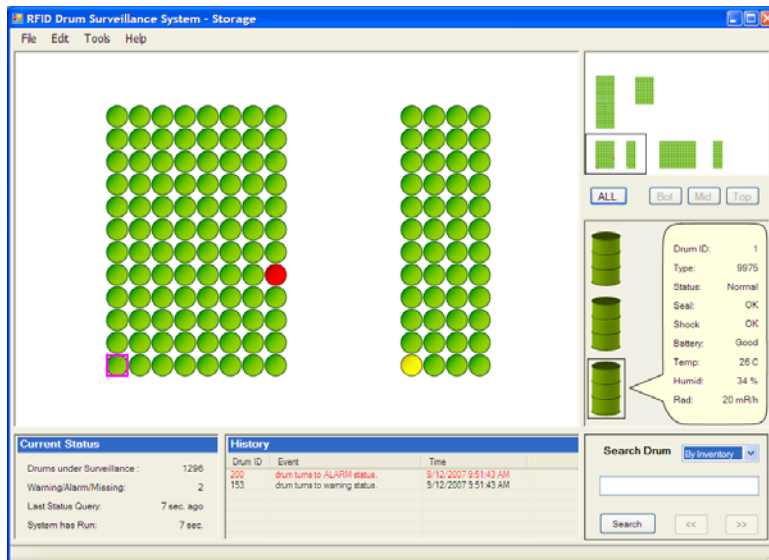

Figure 5. A sample application software GUI for drum storage

Specific GUIs can be designed to handle different applications, e.g., storage or transport. Figure 6 shows a GUI screen for drum transport. Like the storage GUI, the transport GUI also has six panes, with nearly identical functional descriptions and purposes as those for the storage GUI. These GUIs can be easily customized for a particular storage site to satisfy its unique requirements. A privilege can be assigned to the system administrator (or designate) to access the administrator GUI, which has functions that are not available to the general users.

The PCP RFID software, including the prototype storage GUI and transportation GUI, was developed on the Savi SiteManager™ platform.¹⁰ The Site Manager provides an application programming interface for communication between the application software and the RFID readers. SiteManager is widely used in both military and commercial applications and was chosen for its rich feature set and mature code-base.

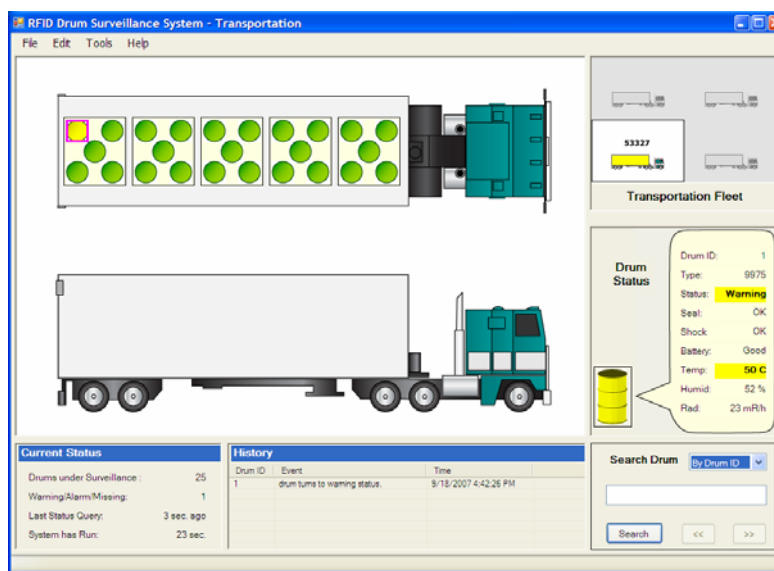

Figure 6. A sample application software GUI for drum transport

Software Feature Set

The prototype software developed based on SiteManager is capable of monitoring thousands of drums simultaneously. If the status of any drum becomes abnormal, the software will bring the user's attention to the situation immediately by triggering an alarm, which, depending on facility provisions, could be a siren, flashing lights, and/or signals sent to the responsible protective force. At the consoles, the operator or security personnel will see a flashing red symbol on the screen, with the cause of the alarm highlighted. The software also provides a convenient interface for the user to send commands to the readers and the tags. These commands include changing the alarm thresholds of the environmental sensors, resetting the alarm state after the corrective actions, updating the drum locations after movements, reading the history file from the tag memory, and searching for specific drums. Some command functions are only available to the system administrator for security and logistic reasons.

The software automatically records in the computer database all the information retrieved from the tags and commands sent to the tags. It also routinely reads the inventory and history files from the tag memory and compares them to the record in the database to guarantee data integrity. The database can be made compatible to the existing systems at each storage site. Privileged remote users can access the data through a secured network. A search function is extremely useful for the inventory management, especially when the size of the inventory is large. This ability allows the operator instant access to information of all packagings that fit the search criteria. The software supports multiple search functions on criteria such as the drum ID, originating site, originating date, arrival dates, and materials stored. In laboratory tests, the search function performed as expected and located the subject drums instantaneously. The search functions can be readily customized by authorized system administrators. The search function and the information registered in the tags provide a powerful basis for a statistical sampling strategy regarding the facility's materials surveillance program for the contents in the drums.

Software Architecture

The adopted software structure of the RFID system is shown schematically in Fig. 7.

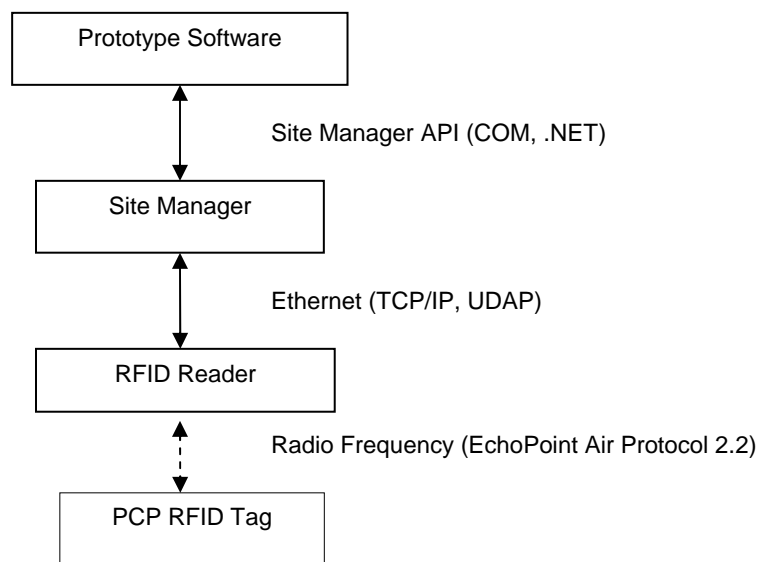

Figure 7. The software structure for the RFID system

The prototype software is written in Microsoft Visual C# and developed for the Microsoft .NET framework. The forward-looking design of the software provides excellent computing performance, lowers the future maintenance effort and cost, and reduces the vulnerability of the software and computers to security threats. The software employs multi-thread technology that is able to handle a large quantity of tags simultaneously and respond to multiple RFID events instantly.

PRELIMINARY SYSTEM TEST RESULTS

A limited number of prototype tags have been produced, and a small-scale RFID system has been built. Initial performance testing of the prototype RFID system (i.e., the tags, the readers, the Signpost, and the application software) has been completed. The preliminary results are summarized as follows:

Read Range

Using the SR-650 reader (ultrahigh frequency, 433 MHz), the tags can be read up to 90 m away in line-of-sight. Using the Signpost (low-frequency, 123 kHz), which primarily serves as a portal, the tags have a read range up to 2.5 m. Both ranges can be reduced by adjusting the RF power level. A potential application of this feature is confining the RF communication inside a predefined region (for example, a portion of a vault or a truck) to enhance security.

Sensor Performance

The tag can be attached onto the drum by two bolts. If either of the bolts is loosened, the seal sensor will trigger an alarm. The tag will send the alarm to the reader immediately and record the event in the tag memory. The software shows the alarm on the computer screen and sends the alarm to a central station for action.

Environmental sensors (temperature, humidity, and shock) can trigger alarms when the preset thresholds are exceeded. When an alarm is triggered, the reading of the sensor and the time when the alarm is triggered are recorded in the event log of the tag sensor memory. The thresholds can be set and reset through the software by the system administrator. When properly configured, the shock sensor can be used to detect unauthorized movement of the drum.

Memory Read/Write

The tags have 128 kB on-board nonvolatile user memory that can store inventory and history files. Coupled with the application software, the tag memory can store files of any conventional formats. The data rate of the RF read or write between the reader and the tag is up to 27.8 kbps. Even though the memory is nonvolatile, the file contents are periodically backed up on the processing computer for redundancy.

Seal Sensor

A long-term durability test on the seal sensors has been under way for six months, during which time the sensors have been periodically compressed and released. Thus far, the variations of the resistances have been negligible compared with the large resistance gap between the compressed and released states. The sensor durability test is continuing.

Battery Life

Due to the footprint constraint, the tags use four relatively small (A-size) Li-SOCl₂ batteries, each having a 3.4 A·hr capacity. A battery drain measurement has been performed to estimate the battery life of the tag. Based on the measurement, the following strategy for near optimal tag usage is suggested.

When no RF operation is taken, the tag is in the sleep mode. When the tag is polled by the reader and initiates an RF operation, it will go through a cycle of three stages. The first is the wake-up stage, which takes 4 to 5 seconds. The second is the operating stage, during which the real operation (querying sensors, memory read/write and status transmission, etc.) takes place. This stage usually lasts less than 1 second. The third is the back-to-sleep stage, which takes about 30 seconds. As the current drain is modest in all three stages, a set of four batteries would last >10 years if the polling frequency is no more than once or twice daily.

The battery life could be shortened by frequent alarm events. But this situation is considered to be extremely unlikely as alarms are expected to be rare. Periodic archiving of the stored user file on the tag to the central computer would also tax the batteries, particularly if the file size is large. But this archiving operation (to detect slow aging of the tag electronics by means of file corruption) can be infrequent, i.e., no more than once a week, and still be effective. Under these assumed operation conditions, the stated battery life of >10 years is feasible.

FUTURE ACTIVITIES

Good operating experience has been gained from the testing of the RFID system so far, and a freeze of the tag design, called Mk-1, is expected shortly. Discussion is underway to build an initial batch of the Mk-1 tags through industrial production. If quantity (several hundreds) is an issue for commercial manufacturing, an option exists for production of a smaller lot of the Mk-1 tags in-house. The unit cost would be higher, and the production rate lower. However, neither is expected to interfere with the use of the Mk-1 tags for field demonstration at DOE sites.

Refinement of the application software is a continuing process. During the course of the upcoming field demonstration, valuable feedback is expected to be received from the field users. The current beta-version of the software could be finalized during or after the field demonstration. Over the longer term, additional application software functionality and features could be added. These may include enhanced analytics and reporting capabilities, increased alerting functionality, remote firmware upgrades, and asset repositioning and optimization functionality.

The number of tags that the RFID system can handle at this time is limited by the reader hardware. One reader can handle several hundred RFID tags simultaneously but is limited by the data transfer rate. A multi-reader network needs to be developed and tested. There is no conceptual difficulty in such a development, and a multiple-reader system should be able to reliably handle thousands of tags on drums. The actual implementation of a working system could turn out to be an art and science.

Security enhancement and vulnerability assessment will be emphasized in the future development. Both the information stored in the tags and the RF communication between the tags and the readers will be encrypted. Only authorized personnel with appropriate equipment will be able to read and write the tags. The software will have user accounts with different levels of privilege. Some operations, such as resetting the alarm, should only be performed by the system administrators. A secured network will be developed for sharing the information only with authorized, off-site users.

SUMMARY

The Packaging Certification Program of EM-60 has developed an RFID system for management of nuclear materials. The development of the RFID system involved hardware modification, software development, and irradiation experiments. Initial testing of the prototype RFID system has been completed with encouraging results. Field testing and demonstration of the RFID system will begin shortly for the Model 9975 drums, which are used for storage and transportation of fissile and radioactive materials. It is anticipated that the RFID system will perform well in the field test and demonstration. The PCP RFID system can be easily adapted for other types of packagings and offers an unprecedented opportunity to modernize the management of all types of DOE fissile and radioactive material packagings.

ACKNOWLEDGMENTS

The authors wish to acknowledge the assistance provided by K. Merritt and P. Burns of Savi Technology; the contributions by S. Wiedmeyer and A. McArthur of Argonne National Laboratory and S. Naday of AVIEX LLC on tag mechanical design and electronic modification and enhancement; and the generous support of the Argonne Dosimetry Group led by D. Pepalis for making the ¹³⁷Cs calibration facility available for the gamma irradiation testing. This work is supported by the U.S. Department of Energy, Environmental Management, Office of Safety Management and Operations (EM-60) under Contract DE-AC02-06CH11357. The U.S. Government retains for itself, and others acting on its behalf, a nonexclusive, royalty-free license with the rights to reproduce, to prepare derivative works, and to display publicly.

This work was prepared as an account of work sponsored by an agency of the United States Government. Neither the United States Government nor any agency thereof, nor UChicago Argonne, LLC, nor any of their employees or officers, makes any warranty, express or implied, or assumes any legal liability or responsibility for the accuracy, completeness, or usefulness of any information, apparatus, product, or process disclosed, or represents that its use would not infringe privately owned rights. Reference herein to any specific commercial product, process, or service by trade name, trademark, manufacturer, or otherwise, does not necessarily constitute or imply its endorsement, recommendation, or favoring by the United States Government or any agency thereof. The views and opinions of document authors expressed herein do not necessarily state or reflect those of the United States Government or any agency thereof, Argonne National Laboratory, or UChicago Argonne, LLC.

REFERENCES

1. d'Hont S., *The Cutting Edge of RFID Technology and Applications for Manufacturing and Distribution*, Texas Instrument TIRIS, April 16, 2004.
2. Jackson R.J., *Radio Frequency Identification (RFID), A White Paper*, December 12, 2004.
3. *The Science of RFID*, ChainLink Research, March 5, 2007.
4. Karygiannis T. et al., *Guidelines for Securing Radio Frequency Identification Systems*, National Institute of Standards and Technology, Special Publication 800-9, April 2007.
5. *Stabilization, Packaging, and Storage of Plutonium-bearing Materials*, U.S. Department of Energy, DOE-STD-3013-2004, April 2004.

6. *Packaging Certification Program, Success Stories, Challenges, and Strategic Directions*, DOE Environmental Management, Office of Safety Management and Operations, 2007.
7. Liu Y.Y. et al, *Life Cycle Management of Radioactive Materials Packaging*, PATRAM 2007.
8. *Savi SensorTag ST-676, ISO Container Door Tag with Intrusion and Environmental Sensors*, Savi Technology, June 11, 2006.
9. *Safety Analysis Report for Packaging, Model 9975, Rev. 0*, Washington Savannah River Company report, WSRC-SA-2002-0000, December 2003.
10. *Savi SmartChain® Site Manager, Unique Network Software for Device and Data Management of RFID and Other Disparate AIDC Systems*, Savi Technology, June 11, 2006.