

**CERTIFICATION PROCEDURE  
FOR THE  
THOR-FLX/HYBRID III RETROFIT VERSION 1.0**

**revised  
September 2004**

**National Highway Traffic Safety Administration  
Vehicle Research and Test Center**

**Certification Procedure for the  
Thor-FLx/HIII Retrofit Version 1.0  
revised June 2004**

**Table of Contents**

|          |   |           |
|----------|---|-----------|
| <b>1</b> | <b>BACKGROUND .....</b>   | <b>1</b>  |
| <b>2</b> | <b>PERFORMANCE REQUIREMENTS .....</b>                                       | <b>3</b>  |
| <b>3</b> | <b>DEFINITION OF FOOT POSITIONS.....</b>                                    | <b>4</b>  |
| <b>4</b> | <b>DYNAMIC IMPACT HARDWARE AND DATA ACQUISITION<br/>TECHNIQUES.....</b>     | <b>5</b>  |
| 4.1      | Dynamic Impactor .....  | 5         |
| 4.2      | Data Acquisition .....  | 5         |
| 4.3      | Ankle Rotary Potentiometer – Zeroing Procedure and Associated Bracket.....  | 6         |
| 4.4      | External Positioning Bracket .....  | 7         |
| <b>5</b> | <b>DYNAMIC IMPACT TEST PROCEDURES AND PERFORMANCE<br/>REQUIREMENTS.....</b> | <b>8</b>  |
| 5.1      | Ball of Foot Impact Test .....  | 8         |
| 5.1.1    | Test Procedure – Ball of Foot Impact (Dorsiflexion) .....                   | 8         |
| 5.1.2    | Performance Specification – Ball of Foot Impact (Dorsiflexion).....         | 10        |
| 5.2      | Heel of Foot Impact .....   | 11        |
| 5.2.1    | Test Procedure – Heel of Foot Impact .....                                  | 11        |
| 5.2.2    | Performance Specifications – Heel of Foot Impact Test .....                 | 12        |
| 5.3      | Inversion/Eversion Impact Test .....  | 13        |
| 5.3.1    | Test Procedure – Inversion/Eversion Impact.....                             | 13        |
| 5.3.2    | Performance Specifications – Inversion/Eversion Impacts .....               | 15        |
|          | <b>APPENDIX A. DESIGN REFERENCE GUIDELINES.....</b>                         | <b>16</b> |
|          | <b>APPENDIX B. VRTC QUASI-STATIC SETUP AND FIXTURES .....</b>               | <b>22</b> |
|          | <b>APPENDIX C. DYNAMIC IMPACT TEST FIXTURES.....</b>                        | <b>30</b> |

## 1 BACKGROUND

This document describes the procedures for certifying the acceptable performance of the 5<sup>th</sup> percentile female advanced dummy lower leg, Thor-FLx/Hybrid III retrofit version 1.0 (Thor-FLx/HIIIr). The Thor-FLx/HIIIr is part of the National Highway Traffic Safety Administration (NHTSA) advanced dummy effort, Thor. The unit is designed for Hybrid III retrofit use and attaches directly to the distal end of the Hybrid III 5<sup>th</sup> percentile female femur.

Thor-FLx/HIIIr is shown in Figure 1. The appropriate flesh elements for the tibia have been removed. Figure 2 is a schematic of the leg defining the key elements of the design. Instrumentation locations are presented in Figure 3. Detailed drawings of the individual components and assemblies can be found in the Thor-FLx/HIIIr drawing package, available at the NHTSA website. In addition, thorough instructions of the product assembly and disassembly are located in the Thor-FLx/HIIIr User's Manual, also available on the NHTSA website ([http://www-nrd.nhtsa.dot.gov/departments/nrd-51/thor\\_flx/ThorFLxweb.html](http://www-nrd.nhtsa.dot.gov/departments/nrd-51/thor_flx/ThorFLxweb.html)).

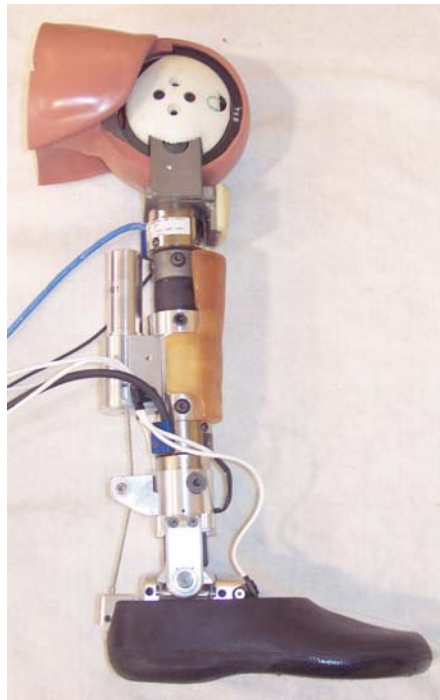

Figure 1. Thor-FLx/HIIIr with Flesh Removed

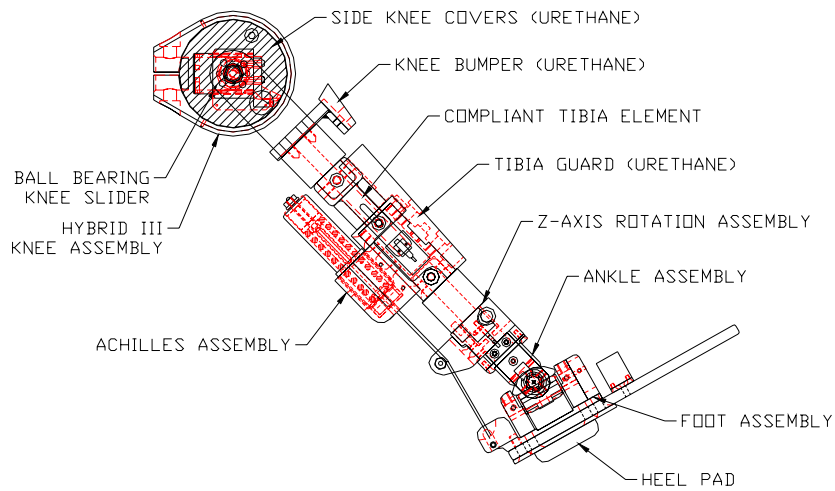

Figure 2. Thor-FLx/HIIIr Schematic Diagram with Key Elements

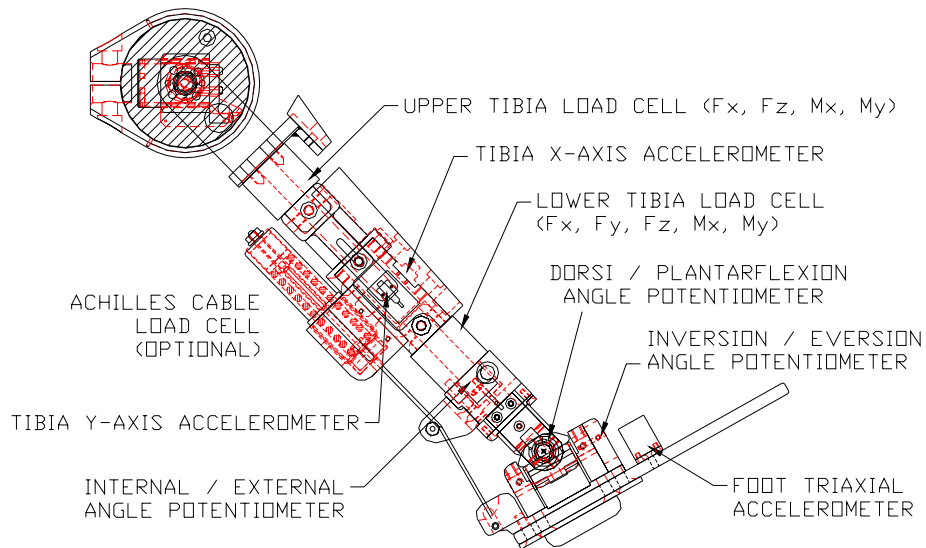

Figure 3. Thor-FLx/HIIIr Schematic Diagram of Instrumentation Locations

## 2 PERFORMANCE REQUIREMENTS

The performance of the Thor-FLx/HIIIr is examined with two sets of criteria:

- certification requirements
- design reference guidelines

For a Thor-FLx/HIIIr to be certified by a manufacturer, it must meet all of the certification requirements. The design reference guidelines are used as an additional functionality confirmation of the product and are listed in Appendix A. Though it is not necessary for certification that the legs meet all of the design reference guidelines, the manufacturer will perform these tests. All manufacturer test data from both mandatory certification requirements and design reference guidelines will be released to the customer with the hardware.

The certification tests consist of four dynamic impacts and the response requirements are summarized in Table 1. The ball of the foot impact validates the dynamic dorsiflexion behavior and the Achilles tendon contribution. The heel impact test examines the tibia axial compliance with a pendulum impact to the heel of the foot. Finally, the dynamic inversion and eversion properties of the ankle are verified by two separate tests -one each for inversion and eversion. For these tests, the foot flesh is removed and an offset bracket is attached to the sole plate. The bracket is configured such that when the impactor strikes it, the ankle motion will result in either inversion or eversion, depending on the test setup. Note that the certification tests can be performed in any sequence, as long as all four tests are completed.

**Table 1.** Thor-FLx/HIIIr Certification Requirements

| Dynamic Impact Test | Criteria                           | Requirement                           |
|---------------------|------------------------------------|---------------------------------------|
| Heel of Foot        | Peak Lower Tibia Compressive Force | 1969 - 2407 N                         |
| Ball of Foot        | Peak Lower Tibia Compressive Force | 2226 - 2721 N                         |
|                     | Peak Ankle Resistive Moment        | 38.4 – 46.9 N- m                      |
|                     | Peak Ankle Rotation                | 34.6 <sup>0</sup> – 42.3 <sup>0</sup> |
| Inversion/Eversion  | Peak Lower Tibia Compressive Force | 305 –373 N                            |
|                     | Peak Ankle Resistive Moment        | 16.5– 20.2 N-m                        |
|                     | Peak Ankle Rotation                | 19.6 <sup>0</sup> – 24.0 <sup>0</sup> |

The test procedures and target response values for the certification requirements and the design reference guidelines are explained in detail in this document, providing the user an option to repeat tests to verify consistent response.

The knee assembly is examined using the standard calibration tests listed in the Code of Federal Regulations Part 572, Subpart O.

### 3 DEFINITION OF FOOT POSITIONS

The sign convention utilized during testing follows the standardized dummy coordinate system listed in the SAE Information Report J211, and is shown in Figure 4. The foot is at  $0^\circ$  plantarflexion and dorsiflexion when the bottom of the foot sole plate is  $90^\circ$  relative to the YZ plane. The foot is at  $0^\circ$  inversion and eversion when the bottom of the foot sole plate is  $90^\circ$  relative to the XZ plane. The foot is at  $0^\circ$  rotation about the Z-axis when the midline of the foot sole plate is  $90^\circ$  relative to the YZ plane. Neutral position of the foot is defined as  $15^\circ$  plantarflexion (bottom plane of the sole plate is rotated  $105^\circ$  from the midline of the tibia),  $0^\circ$  inversion and eversion, and  $0^\circ$  rotation about the Z-axis. Neutral position is depicted in Figure 5. The sign convention for dorsiflexion is positive rotation about the Y-axis, while plantarflexion is negative rotation about the Y-axis. Inversion is the action of turning the sole of the foot inward, towards the opposite foot, while eversion is the movement of turning the sole of the foot outward, away from the midline. In Figure 4, a right foot is shown.

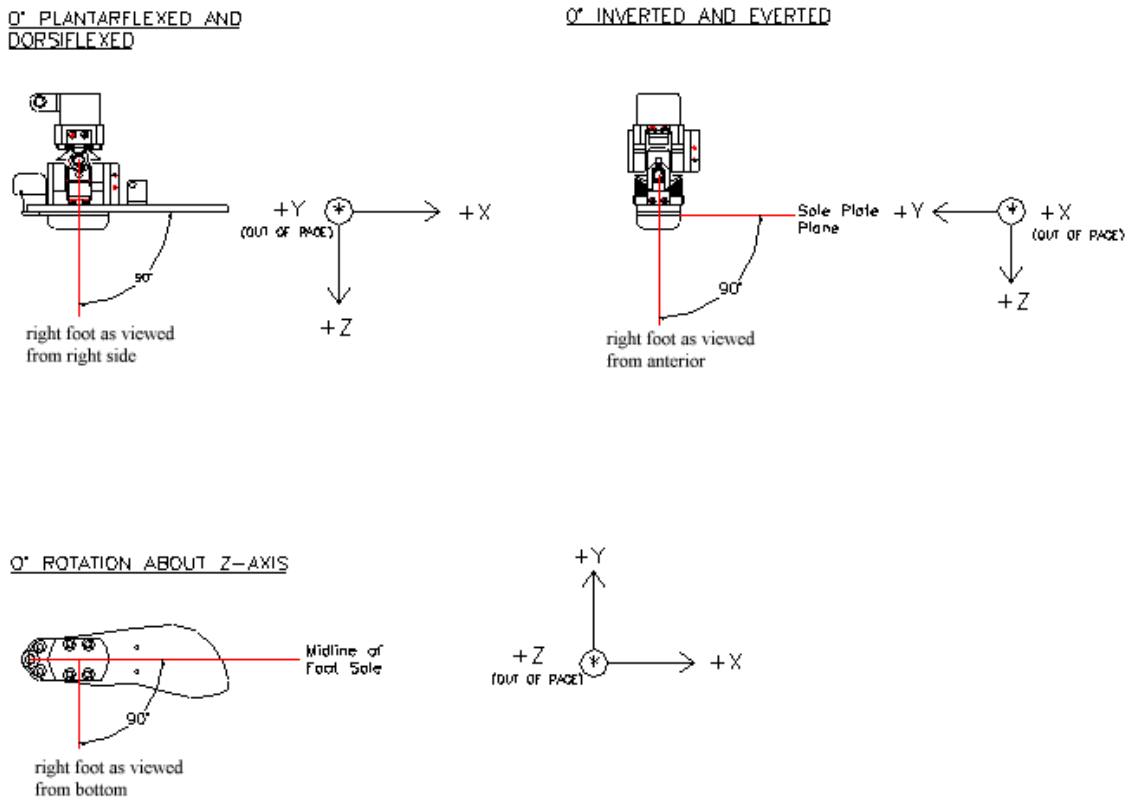

Figure 4. Definition of Foot Positions

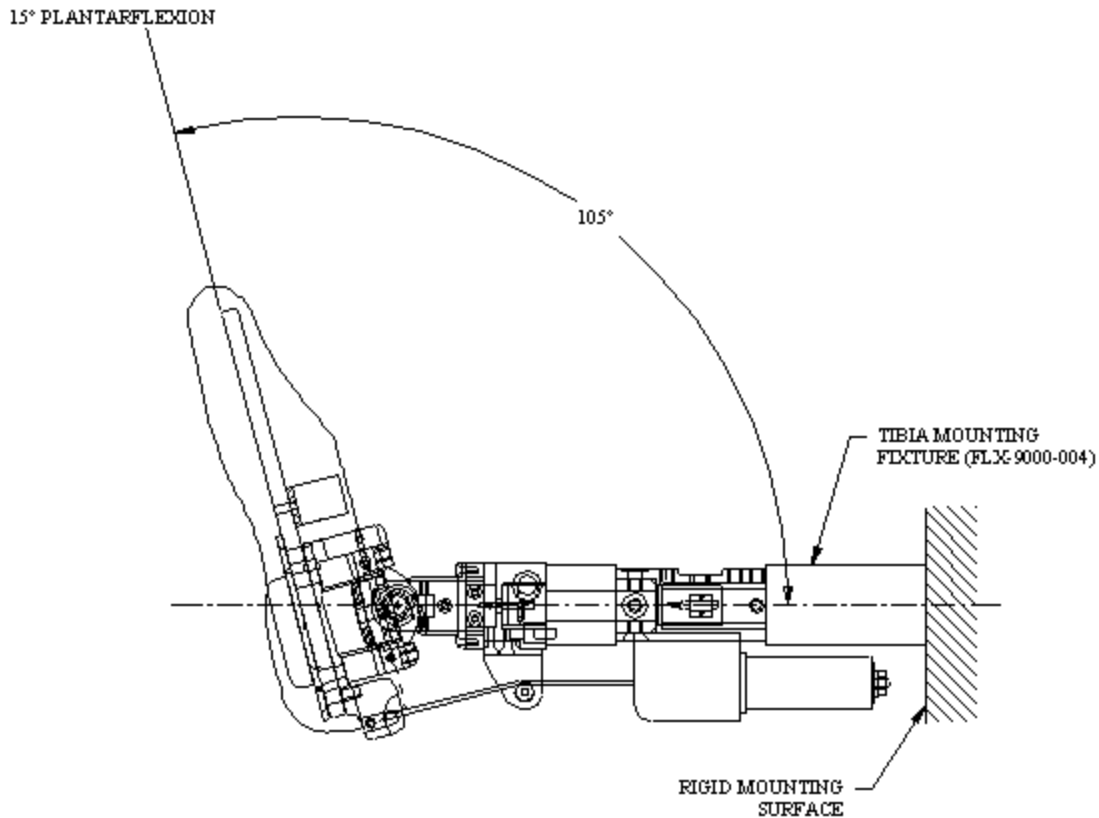

Figure 5. Thor-FLx/HIIIr in Neutral Position

## 4 DYNAMIC IMPACT HARDWARE AND DATA ACQUISITION TECHNIQUES

### 4.1 Dynamic Impactor

The impactor used for the dynamic impact tests is shown in Figure 6. This impactor is identical to the one used for the Thor Lx certification procedures (reference FLX-9000-013), except for the impactor ballast mass. The combined mass of the FLx impactor face, ballast, and 1/3 of the supporting tube is 3.00 +/- 0.02 kg (6.68 +/- 0.04 lbs). Because the densities and weights of some materials may vary, slight adjustment of the dimensions may be needed to achieve the same mass. Detailed drawings of the individual pendulum arm components are shown in Appendix C. The pendulum arm is mounted to a rigid shaft which is pivoted on low friction ball bearings. The supporting structure for the NHTSA Dynamic Impactor is determined by the test facility.

### 4.2 Data Acquisition

The data acquisition system must conform to requirements of the 1996 revision of SAE-J211. Filter all force and moment data channels using CFC 600 phaseless filters and filter the ankle rotary potentiometer channels at CFC 180.

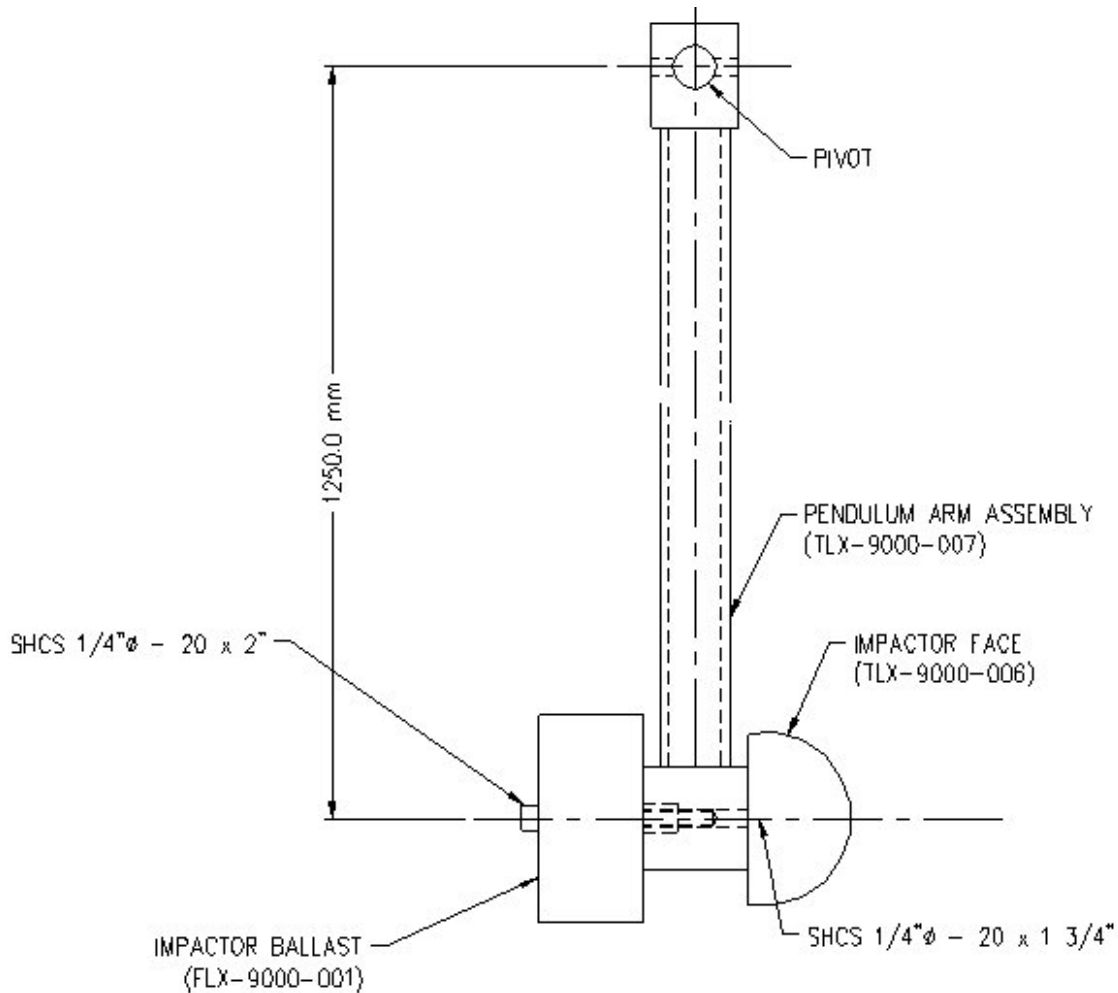

Figure 6. NHTSA Dynamic Impactor for Thor-FLx Certification Tests

### 4.3 Ankle Rotary Potentiometer – Zeroing Procedure and Associated Bracket

Before conducting any of the dynamic impact tests, it is necessary to determine the voltage outputs of the individual ankle potentiometers when the ankle is held in a known orientation referred to as the “zero position.” The zero position is defined as the location at which the foot is at zero degrees plantar-/dorsiflexion, zero degrees inversion/eversion, and rotated zero degrees about the z-axis (reference Section III). The zero position potentiometer voltage values, along with the rotational calibration values in degrees per volt (which should be supplied by the manufacturer or determined experimentally), are later used to determine the angular position of the foot relative to the tibia. To perform the zero position calibration, a bracket which holds the foot fixed in the zero position is required. An example of such a bracket (T2CEM420) is shown in Figure 7. A detailed explanation of the ankle rotary potentiometer calibration procedures can be found in the Thor-FLx/HIIIr User’s Manual.

If all three of the dynamic impact tests (ball of foot, heel, and inversion/eversion) are to be conducted sequentially and without interruption, it is acceptable to conduct the zero position calibration only one time, prior to starting the first test. However, if the hardware is to be unplugged from the data acquisition system or if the ankle assembly is



to be disassembled in any way, then the zero position calibration may need to be repeated.

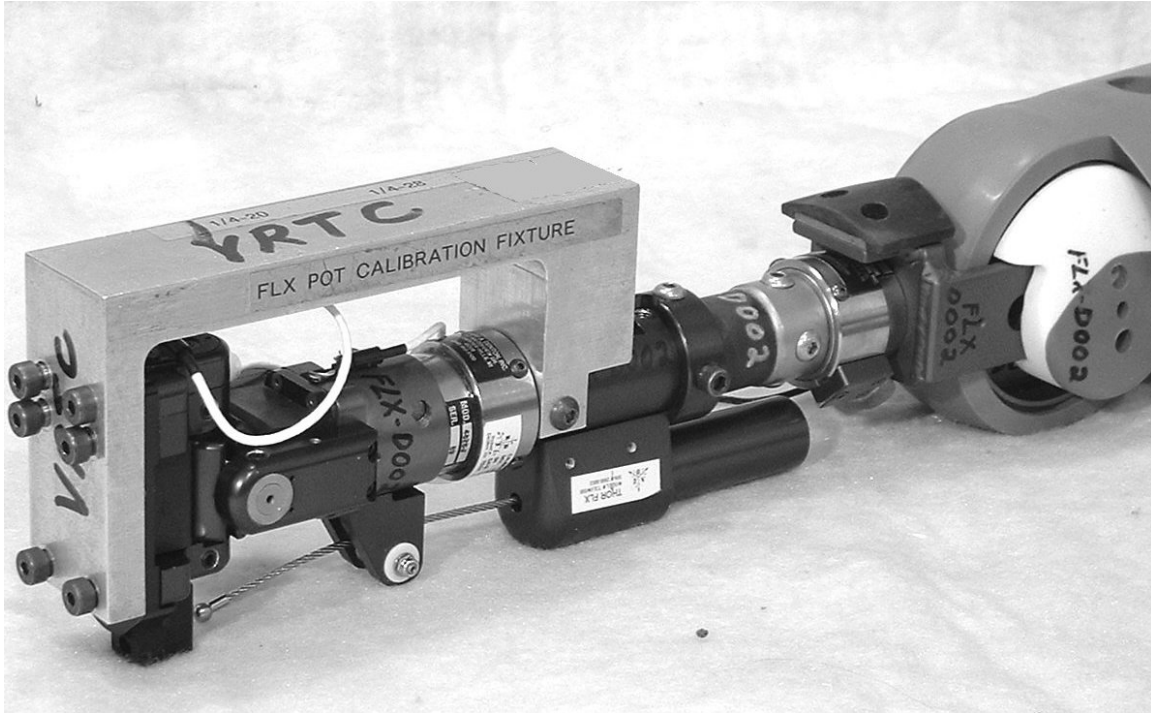

Figure 7. Thor-FLx Ankle Rotary Potentiometer Zeroing Fixture

#### 4.4 External Positioning Bracket

The heel impact and inversion/eversion tests both require the foot to be held in a position perpendicular to the tibia tube ( $0^{\circ} \pm 1/2^{\circ}$  plantarflexion) during the impact. To achieve this, an external positioning bracket may be used. An example of an external positioning bracket is shown in Figures 8a and 8b. This bracket is held in tension around the ankle center block dorsiflexion stops and the ankle flange.

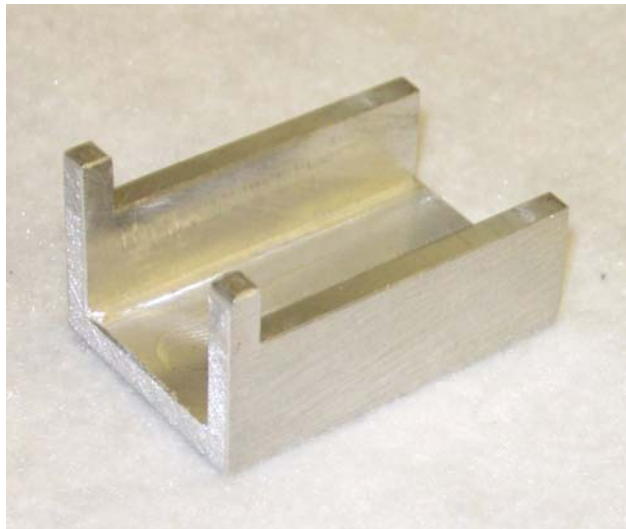

Figure 8a. External Positioning Bracket

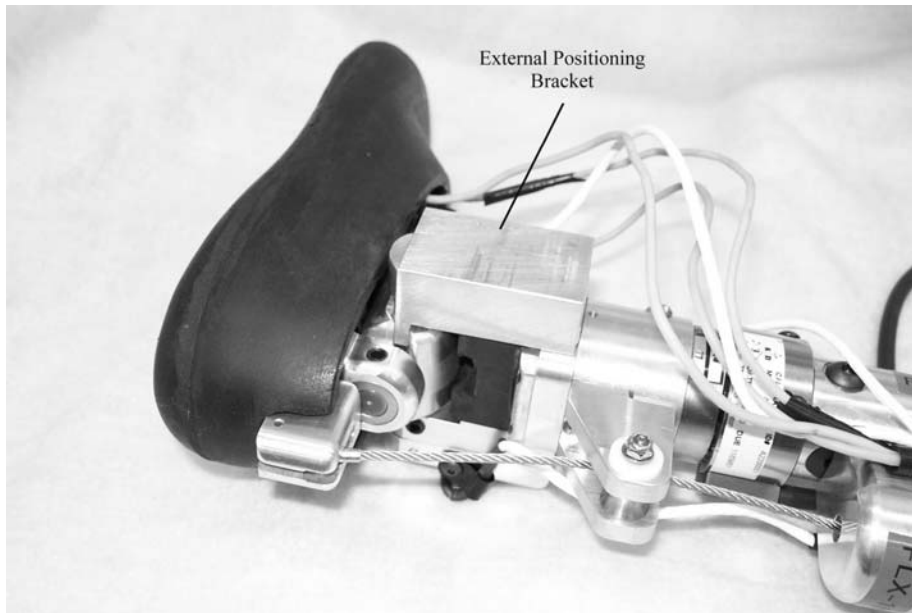

Figure 8b. External Positioning Bracket In Use on FLx Leg

## 5 DYNAMIC IMPACT TEST PROCEDURES AND PERFORMANCE REQUIREMENTS

### 5.1 Ball of Foot Impact Test

This test consists of a dynamic impact to the ball of the foot. The leg is held rigidly with the tibia horizontal as shown in Figure 9, without the presence of the tibia compliant element.

Required Hardware:

- foot assembly
- ankle assembly
- tibia assembly
- Achilles assembly
- tibia mounting fixture (FLX-9000-004, Figure C-4)

Required Instrumentation:

- five channel lower tibia load cell
- Y-axis ankle rotary potentiometer

#### 5.1.1 Test Procedure – Ball of Foot Impact (Dorsiflexion)

1. Inspect the ankle soft stops for tears, permanent deformations, or separation from the soft stop brackets. Inspect the foot skin for wear and tears. Replace components that have experienced excessive wear.

2. Soak the ankle, foot, and tibia assemblies in a controlled environment at a temperature between 69° and 72° F for at least four hours prior to a test. The test environment should have the same temperature as the soak environment.
3. Remove the tibia flesh from the leg. Remove the tibia compliant bushing assembly at the lower flange joint and mount the leg to the tibia mounting fixture, with the toe pointing upward, as shown in Figure 9. The certification corridors were designed with the tibia compliant bushing assembly removed, and testing with this assembly attached to the leg may alter performance. The test fixture must be rigidly secured so that it does not move or vibrate excessively during impact.
4. Attach the Achilles spring cable to the lower Achilles mounting post and verify that the spring cable tension is correctly adjusted (see Thor-FLx/HIIIr User's Manual).
5. Zero the instrumentation channels, except for the rotary potentiometers. Rotary potentiometer channels should be set according to calibration values provided by the manufacturer and verified for accuracy (see Thor-FLx/HIIIr User's Manual.)
6. Allow the foot to rest in the neutral position (Figure 5). Verify with the Y-axis potentiometer that the foot is at 15 +/- 0.5° plantarflexion. Leave the foot in the neutral position for impact. Readjust the foot to this position between impacts.
7. Adjust the fixture so that the longitudinal centerline of the pendulum arm is vertical at impact, within +/- 0.5°, and the point of impact is 92.5 +/- 2.5 mm (3.64 +/-0.1 in) above the ankle Y-axis pivot point (reference Figure 9).
8. Wait at least 30 minutes between successive impacts to the same foot.

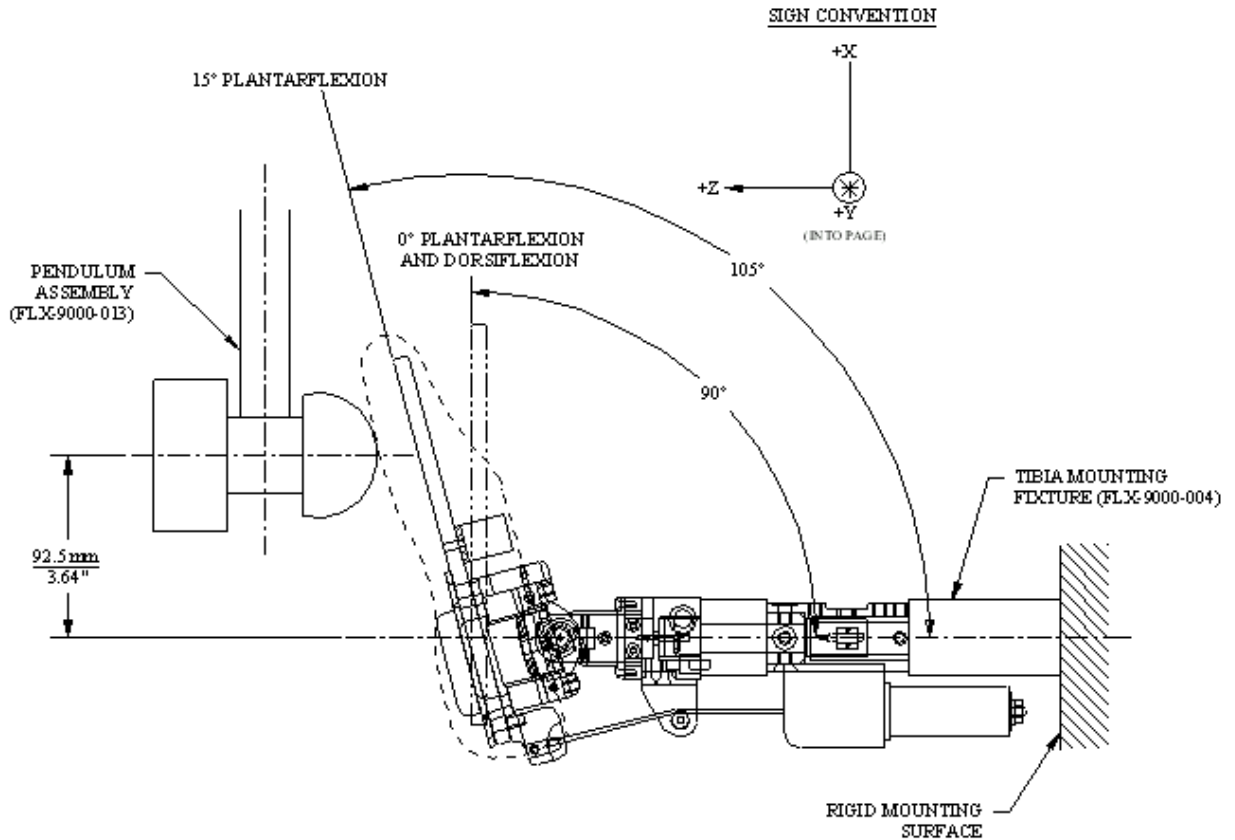

Figure 9. Ball of Foot Impact Test Setup

### 5.1.2 Performance Specification – Ball of Foot Impact (Dorsiflexion)

1. Release the pendulum and allow it to fall freely from a height to achieve an impact velocity of  $5.0 \pm 0.1$  m/s ( $16.4 \pm 0.3$  ft/s).
2. Time-zero is defined as the time of initial contact between the pendulum impactor and the ball of the foot. All channels, except for the rotary potentiometer(s), should be electronically set to zero at this time.
3. At a minimum, record the following data channels (other channels are optional):
  - Lower Tibia Load Cell -  $F_x$ ,  $F_z$ ,  $M_y$
  - Y-axis Rotary Potentiometer
4. Compute the ankle resistive moment.
  - $M_{\text{ankle}} = M_y - (a * F_x)$  where:
  - $M_y$  = Moment about Y-axis measured at lower tibia load cell
  - $F_x$  = Force measured in X-direction at lower tibia load cell
  - $a$  = distance from center of lower tibia load cell to dorsiflexion ankle joint (for Thor-FLX/HIIIr,  $a = 0.0884$  m)

- The performance requirements are listed below in Table 2.

Table 2. Certification corridors for ball of foot impact test.

| Criteria                          | Requirement     |
|-----------------------------------|-----------------|
| Peak Lower Tibia Compressive Load | 2226 - 2721 N   |
| Peak Ankle Resistive Moment       | 38.4 – 46.9 N-m |
| Peak Ankle Y-Axis Rotation        | 34.6° – 42.3°   |

## 5.2 Heel of Foot Impact

This test consists of a pendulum impact to the heel of the foot. The leg is held rigidly with the tibia horizontal (Figure 10).

Required Hardware:

- foot assembly
- ankle assembly
- tibia assembly
- Achilles assembly
- ankle external positioning bracket (reference Figures 8a and 8b)

Required Instrumentation:

- five channel lower tibia load cell

### 5.2.1 Test Procedure – Heel of Foot Impact

1. Inspect the tibia compliant bushing assembly for fatigue and deformation. Check the plunger retaining bolts which secure the compliant bushing to the lower tibia tube for wear. Inspect the foot skin for wear and tear. Replace components that have experienced excessive wear.
2. Soak the ankle, foot, and tibia assemblies in a controlled environment at a temperature between 69° and 72° F for at least four hours prior to a test. The test environment should have the same temperature as the soak environment.
3. Remove the tibia flesh. Remove the knee clevis and mount the tibia to the test fixture at the proximal end of the upper tibia load cell or load cell simulator with the toe pointing upward, as shown in Figure 10. The test fixture must be rigidly secured so that it does not move or vibrate excessively during impact.
4. Attach the Achilles spring cable to the lower Achilles mounting post and verify that the spring cable tension is correctly adjusted (see Thor-FLx/HIIIr User's Manual).

5. Orient the foot at  $0^{\circ} \pm 0.5^{\circ}$  plantarflexion (Figure 10). Use an external positioning bracket to hold the ankle in this orientation (reference Figures 8a and 8b).
6. Zero the instrumentation channels, except for the rotary potentiometers. Rotary potentiometer channels should be set according to the calibration sheets provided by the manufacturer and verified for accuracy (see Thor-FLx/HIIIr User's Manual)
7. Adjust the fixture so that the longitudinal centerline of the pendulum arm is vertical at impact, within  $\pm 0.5^{\circ}$ , and the impact point is aligned with the longitudinal axis of the tibia, within  $\pm 2.5$  mm ( $\pm 0.1$  in) (Figure 10).
8. Wait at least 30 minutes between successive impacts to the same foot.

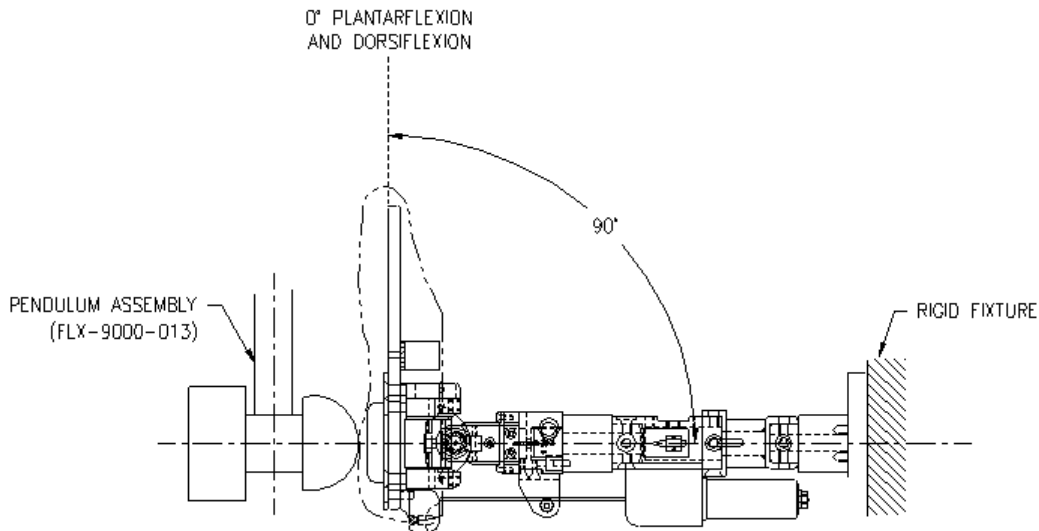

Figure 10. Heel Impact Test Setup

### 5.2.2 Performance Specifications – Heel of Foot Impact Test

1. Release the pendulum and allow it to fall freely from a height to achieve an initial impact velocity of  $4.0 \pm 0.1$  m/s ( $13.1 \pm 0.3$  ft/s).
2. Time-zero is defined as the time of initial contact between the pendulum impactor and the heel of the foot. All channels should be zero at this time.
3. The only data channel required is the lower tibia load cell  $F_z$  (axial) channel. All other channels are optional.
4. The peak compressive force measured by the lower tibia load cell should be within the range of 1969 - 2407 N.

### 5.3 Inversion/Eversion Impact Test

These tests consist of two impacts (one each for inversion and eversion) to a padded bracket which is attached to the sole plate of the foot. The bracket is attached such that the line of impact is offset from the longitudinal axis of the tibia, and the resulting motion of the foot exercises the inversion and eversion properties of the ankle assembly. The leg is held rigidly such that the X-Z plane of the foot and lower leg are horizontal as shown in Figure 11. The impact surface of the bracket is covered with Ensolite padding to reduce noise transmission through the bracket into the ankle and load cell.

#### Required Hardware:

- foot assembly
- ankle assembly
- tibia assembly
- Achilles assembly
- ankle external positioning bracket
- dynamic inversion/eversion bracket (Fig. C-5, FLX-9000-015)
- tibia mounting fixture (Fig. C-4, FLX-9000-004)

#### Required Instrumentation:

- five channel lower tibia load cell
- X-axis ankle rotary potentiometer

#### 5.3.1 Test Procedure – Inversion/Eversion Impact

1. Remove the following items from the leg:
  - tibia flesh
  - foot flesh
  - tibia compliant bushing assembly
  - the four flat head cap screw at the forward-most and rearward-most location on the inferior side of the foot; the two screws at the toe-end are ¼” x 20 x 1” while the two at the heel-end are ¼” x 20 x ¾”.
2. Attach the dynamic inversion/eversion bracket to the bottom (inferior) side of the foot sole plate. The forward-most (toe end) holes will require ¼” x 20 x 2” sockey head cap screws, while the rearward-most (heel end) holes will require ¼” x 20 x 1.75”. (Note: Use of bolts longer than that specified above may damage the inversion/eversion soft stop brackets.)
3. Inspect the ankle soft stops for tears, permanent deformations, or separation from the soft stop brackets. Replace components that have experienced excessive wear.
4. Soak the ankle, foot, and tibia assemblies and the dynamic inversion/eversion bracket in a controlled environment at a temperature between 69<sup>o</sup> and 72<sup>o</sup> F for at

least four hours prior to a test. The test environment should have the same temperature as the soak environment.

5. Mount the leg to the tibia mounting fixture at the lower flange, such that the X-Z plane of the foot and lower leg are horizontal as shown in Figure 11. The test fixture must be rigidly secured so that it does not move or vibrate excessively during impact.
6. Attach the Achilles spring cable to the lower Achilles mounting post and verify that the spring cable tension is correctly adjusted (see Thor-FLx/HIIIr User's Manual).
7. Zero the instrumentation channels, except for the rotary potentiometers. Rotary potentiometer channels should be set according to calibration values provided by the manufacturer and verified for accuracy (see Thor-FLx/HIIIr User's Manual).
8. Orient the foot at  $0^{\circ} \pm 0.5^{\circ}$  dorsiflexion/plantarflexion and inversion/eversion. Use an external positioning bracket to hold the ankle in this orientation (reference Figures 8a and 8b).
9. Adjust the fixture so that the longitudinal centerline of the pendulum arm and the struck surface of the inversion/eversion bracket are vertical at impact, within  $\pm 0.5^{\circ}$  and the point of impact is  $92.5 \pm 2.5$  mm ( $4.04 \pm 0.1$  in) above the ankle X-axis pivot point (Figure 11).
10. Wait at least 30 minutes between successive impacts to the same foot.

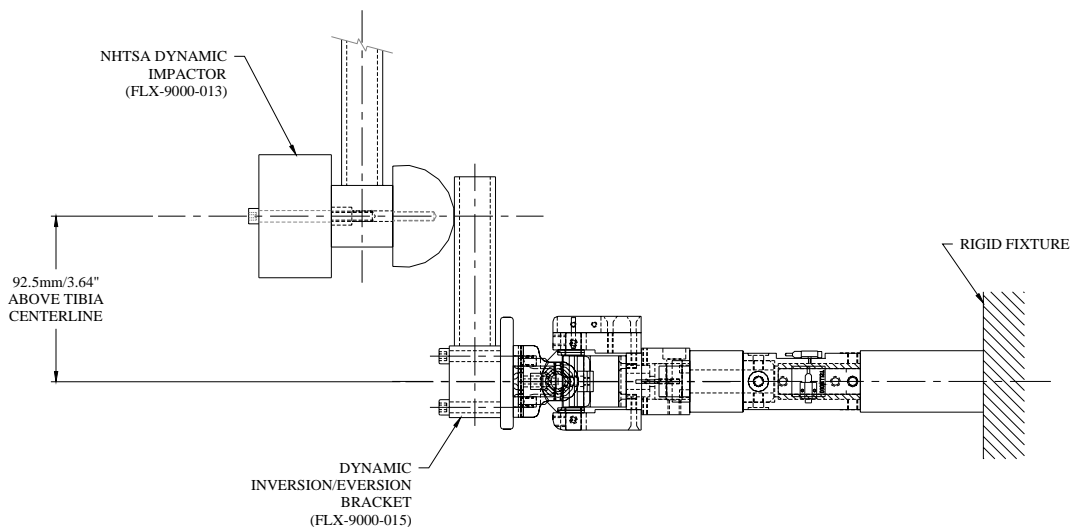

Figure 11. Dynamic Inversion/Eversion Impact Test Setup



### 5.3.2 Performance Specifications – Inversion/Eversion Impacts

1. Release the pendulum and allow it to fall freely from a height to achieve an impact velocity of 2.0 +/- 0.1 m/s.
2. Time zero is defined as the time of initial contact between the pendulum impactor and the inversion/eversion bracket. All channels should be zero at this time, except for the rotary potentiometer(s).
3. At a minimum, record the following data channels (other channels are optional):
  - Lower tibia Load Cell –  $F_y$ ,  $F_z$ ,  $M_x$
  - X-axis Ankle Rotary Potentiometer
4. Compute the ankle resistive moment.
  - $M_{\text{ankle}} = M_x + (a * F_y)$ , where:
  - $M_x$  = moment about the X-axis measured at the lower tibia load cell
  - $F_y$  = force measured in Y-direction at lower tibia load cell
  - $a$  = distance from center of lower tibia load cell to inversion/eversion ankle joint (for Thor-FLx/HIIIr,  $a = 0.0981$ )
5. The performance requirements are listed in Table 3.

Table 3. Inversion/Eversion Performance Requirements

| Criteria                          | Requirement                           |
|-----------------------------------|---------------------------------------|
| Peak Lower Tibia Compressive Load | 305 – 373 N                           |
| Peak Ankle Resistive Moment       | 16.5 – 20.2 N-m                       |
| Peak Ankle X-Axis Rotation        | 19.6 <sup>o</sup> – 24.0 <sup>o</sup> |

## **APPENDIX A. DESIGN REFERENCE GUIDELINES**

The design reference guidelines for the Thor-FLx/HIIIr can be separated into two categories: (1) component tests specified in the drawing package; and (2) quasi-static tests of the ankle motion. The component tests are listed in Table A-1 below along with the corresponding drawing number containing the test description. The quasi-static tests are described in this appendix. All manufacturer test data from both the mandatory certification requirements and the design reference guidelines will be released to the customer with the hardware.

Table A-1. Component tests specified in the drawing package

| Test Description                                    | Drawing # |
|---|-----------|
| Tibia compliant bushing quasi-static compression    | T2LLM412  |
| Heel pad static compression                         | T2FTM214  |
| Achilles spring rate static test                    | T2LLM300  |
| Achilles elastomeric spring element                 | T2LLM300  |
| Static internal/external rotation requirement       | T2LXM001  |
| Rotary potentiometer 10-point calibration procedure | T2AKM000  |

## QUASI-STATIC TESTS

The quasi-static ankle motion tests examine the range of motion and resistance of the ankle joint soft stops in inversion/eversion, dorsiflexion (with and without the Achilles) and plantarflexion.

The test fixtures used in the quasi-static ankle motion tests can be determined by the individual test labs and are subject to variation. As an example, the experimental setup used at the NHTSA Vehicle Research and Test Center (VRTC) is presented in detail along with accompanying figures and sample test data in Appendix B.

The Thor-FLx/HIIIr parts required for the quasi-static tests are:

- Ankle Assembly
- Achilles Assembly
- Tibia Assembly
- X-, Y-, and Z-axis Rotary Potentiometers

## Quasi-Static Inversion/Eversion Tests

### Inversion/Eversion Test Procedure

1. Inspect the inversion/eversion soft stop assemblies for uneven wear, tears, or other damage. Check for smooth rotation of the ankle about all three axes.
2. Soak the ankle, foot, and tibia assemblies in a controlled environment at a temperature between 69° and 72° F for at least four hours prior to testing. The test environment should have the same temperature as the soak environment.
3. Rigidly mount the tibia and align the foot at the zero position (0° dorsiflexion, plantarflexion, inversion, and eversion, 0° rotation about Z-axis, +/- 0.5 degree on all axes). Since the Thor-FLx/HIIIr foot naturally rests at 15° plantarflexion, an external positioning bracket will be necessary to hold the foot at 0° plantarflexion for the inversion/eversion tests (reference Figures 8a and 8b). (Note: Rotation about the Z-axis is undesirable during the quasi-static tests and should be prevented.)
4. Detach the Achilles cable from the lower Achilles mounting post by removing the #4 - 40 x 1/2" socket head cap screw and sliding the ball of the cable out of the slot at the back of the heel. (See Thor-FLx/HIIIr User's Manual)
5. Verify the potentiometer accuracy by following the ankle potentiometer zeroing procedure outlined in Section 4 of the main document. (See Thor-FLx/HIIIr User's Manual).
6. Rotate the ankle from the initial starting position to 37-38° inversion or eversion at a rate of 1-2°/second. (Note: Do not rotate beyond 38° to avoid damage as this angle is near the joint mechanical limit.)
7. Calculate the torque at the ankle joint. Sample calculations for the VRTC test setup are shown in Appendix B.

### Inversion/Eversion Response Requirements

The angle at which the following torque values are measured should be within the corresponding ranges:

| Torque (N-m) | Angle (degrees) |
|--------------|-----------------|
| 8            | 19.2 – 23.4     |
| 17           | 28.5 – 34.9     |

## Quasi-Static Dorsiflexion with Achilles Cable

### Dorsiflexion with Achilles Cable Test Procedure

1. Inspect the dorsiflexion/plantarflexion soft stop assemblies for uneven wear, tears, or other damage. Check for smooth rotation of the ankle about all three axes.
2. Soak the ankle, foot, and tibia assemblies in a controlled environment at a temperature between 69° and 72° F for at least four hours prior to testing. The test environment should have the same temperature as the soak environment
3. Rigidly mount the tibia and allow the Thor-FLx/HIIIr foot to rest naturally in the neutral position at 15° plantarflexion, 0° inversion and eversion, 0° rotation about Z-axis, +/- 0.5 degree on all axes.
4. Attach the Achilles spring cable to the lower Achilles mounting post and verify that the spring cable tension is correctly adjusted. (See Thor-FLx/HIIIr User's Manual).
5. Verify the potentiometer accuracy by following the ankle potentiometer zeroing procedure outlined in Section 4 of the main document. (See Thor-FLx/HIIIr User's Manual).
6. Rotate the ankle from the initial starting position (15° plantarflexion) to 40-42° dorsiflexion at a rate of 1-2°/second. (Note: Do not rotate beyond 42° to avoid damage as this angle is near the joint mechanical limit.)
7. Calculate the torque at the ankle joint. Sample calculations for the VRTC test setup are shown in Appendix B.

### Dorsiflexion with Achilles Cable Response Requirements

The angle at which the following torque values are measured should be within the corresponding ranges:

| Torque (N-m) | Angle (degrees) |
|--------------|-----------------|
| 25           | 18.7 – 22.9     |
| 55           | 33.2 – 40.6     |

## Quasi-Static Dorsiflexion without Achilles Cable

### Dorsiflexion without Achilles Cable Test Procedure

1. Inspect the dorsiflexion/plantarflexion soft stop assemblies for uneven wear, tears, or other damage. Check for smooth rotation of the ankle about all three axes.
2. Soak the ankle, foot, and tibia assemblies in a controlled environment at a temperature between 69° and 72° F for at least four hours prior to testing. The test environment should have the same temperature as the soak environment
3. Rigidly mount the tibia and allow the Thor-FLx/HIIIr foot to rest naturally in the neutral position at 15° plantarflexion, 0° inversion and eversion, 0° rotation about Z-axis, +/- ½ degree on all axes.
4. Detach the Achilles cable from the lower Achilles mounting post by removing the #4 - 40 x 1/2" socket head cap screw and sliding the ball of the cable out of the slot at the back of the heel. (See Thor-FLx/HIIIr User's Manual)
5. Verify the potentiometer accuracy by following the ankle potentiometer zeroing procedure outlined in Section 4 of the main document. (See Thor-FLx/HIIIr User's Manual).
6. Rotate the ankle from the initial starting position (15° plantarflexion) to 40-42° dorsiflexion at a rate of 1-2°/second. (Note: Do not rotate beyond 42° to avoid damage as this angle is near the joint mechanical limit.)
7. Calculate the torque at the ankle joint. Sample calculations for the VRTC test setup are shown in Appendix B.

### Dorsiflexion without Achilles Cable Response Requirements

The angle at which the following torque values are measured should be within the corresponding ranges:

| Torque (N-m) | Angle (degrees) |
|--------------|-----------------|
| 9            | 20.2 – 24.6     |
| 25           | 35.0 – 42.8     |

## Quasi-Static Plantarflexion Test

### Plantarflexion Test Procedure

1. Inspect the dorsiflexion/plantarflexion soft stop assemblies for uneven wear, tears, or other damage. Check for smooth rotation of the ankle about all three axes.
2. Soak the ankle, foot, and tibia assemblies in a controlled environment at a temperature between 69° and 72° F for at least four hours prior to testing. The test environment should have the same temperature as the soak environment
3. Rigidly mount the tibia and allow the Thor-FLx/HIIIr foot to rest naturally in the neutral position at 15° plantarflexion, 0° inversion and eversion, 0° rotation about Z-axis, +/- ½ degree on all axes.
4. Detach the Achilles spring cable from the lower Achilles mounting post by removing the #4-40 x ½ inch socket head cap screw and sliding the ball of the cable out of the slot at the back of the heel (see Thor-FLx/HIIIr User's Manual).
5. Verify the potentiometer accuracy by following the ankle potentiometer zeroing procedure outlined in Section 4 of the main document. (See Thor-FLx/HIIIr User's Manual).
6. Rotate the ankle from the initial starting position (15° plantarflexion) to 55-57° dorsiflexion at a rate of 1-2°/second. (Note: Do not rotate beyond 57° to avoid damage as this angle is near the joint mechanical limit.)
7. Calculate the torque at the ankle joint. Sample calculations for the VRTC test setup are shown in Appendix B.

### Plantarflexion Response Requirements

The angle at which the following torque values are measured should be within the corresponding ranges:

| Torque (N-m) | Angle (degrees) |
|--------------|-----------------|
| 3            | 28.2 – 34.4     |
| 17           | 44.0 – 53.8     |

## **APPENDIX B. VRTC QUASI-STATIC SETUP AND FIXTURES**



This appendix describes the experimental setup used for the quasi-static tests at VRTC. This description is meant to be an example; it is not necessary to replicate this setup to run the quasi-static tests.

The equipment and fixtures utilized in this test are:

- Universal material testing machine
- Steel cable of length 559 mm (22 in)
- Rigid fixture to horizontally mount Thor-FLx/HIIIr to universal testing machine
- Ankle Moment Arm (FLX-9000-014, Figure B-6)
- Cable Attachment Bracket (TLX-9000-12, Figure B-7)

The data acquisition system must conform to the requirements of the 1996 revision of SAE Recommended Practice J211. Filter all data channels using Channel Filter Class 600 phaseless filters.

### Test Procedure

1. Remove the foot flesh and attach the ankle moment arm to the bottom of the ankle/Achilles mounting plate (T2FTM210) with ¼” – 20 flat head cap screws – two screws of length 1-1/4” at the forward (toe) end and two 1” long screws at the rearward (heel) end, as shown in Figure B-1. The length of the moment arm for this fixture is 254 mm (10 in).

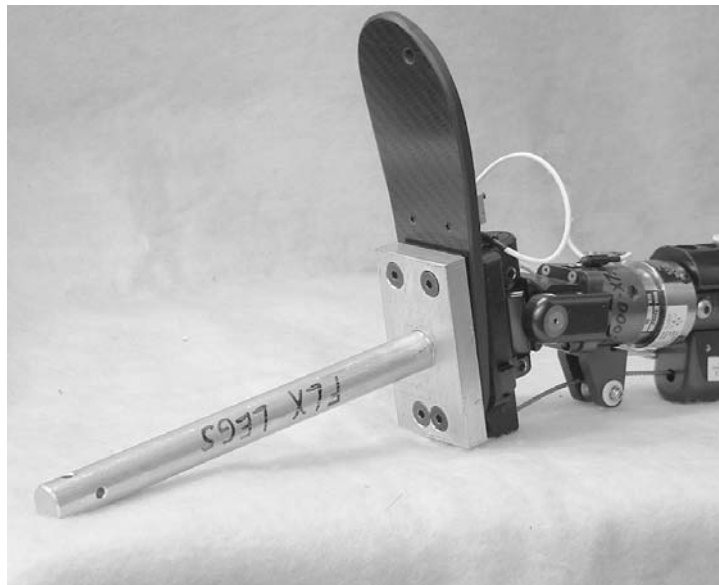

Figure B-1. Quasi-static ankle moment arm attachment

2. Rigidly and horizontally mount the tibia to the universal testing machine and align the leg as described in Table B-1.

Table B-1. Quasi-static test mounting orientations

| Test               | Plantarflexion Angle (deg) | Inversion/Eversion Angle (deg) | Rotation about Z-axis (deg) |
|--------------------|----------------------------|--------------------------------|-----------------------------|
| Dorsiflexion       | 15                         | 0                              | 0                           |
| Plantarflexion     | 15                         | 0                              | 0                           |
| Inversion/Eversion | 0                          | 0                              | 0                           |

Note: The setup tolerance for all angular positions is  $\pm 0.5^\circ$ .

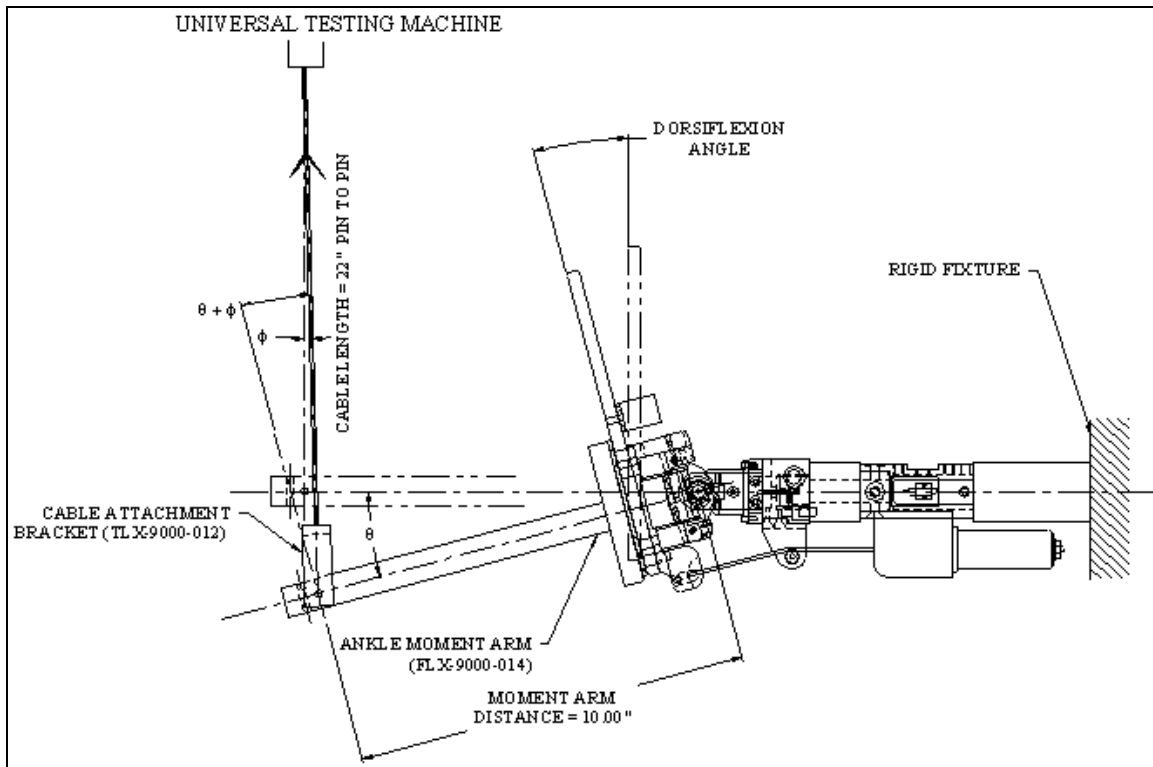

Figure B-2. Quasi-static Dorsiflexion Test Setup

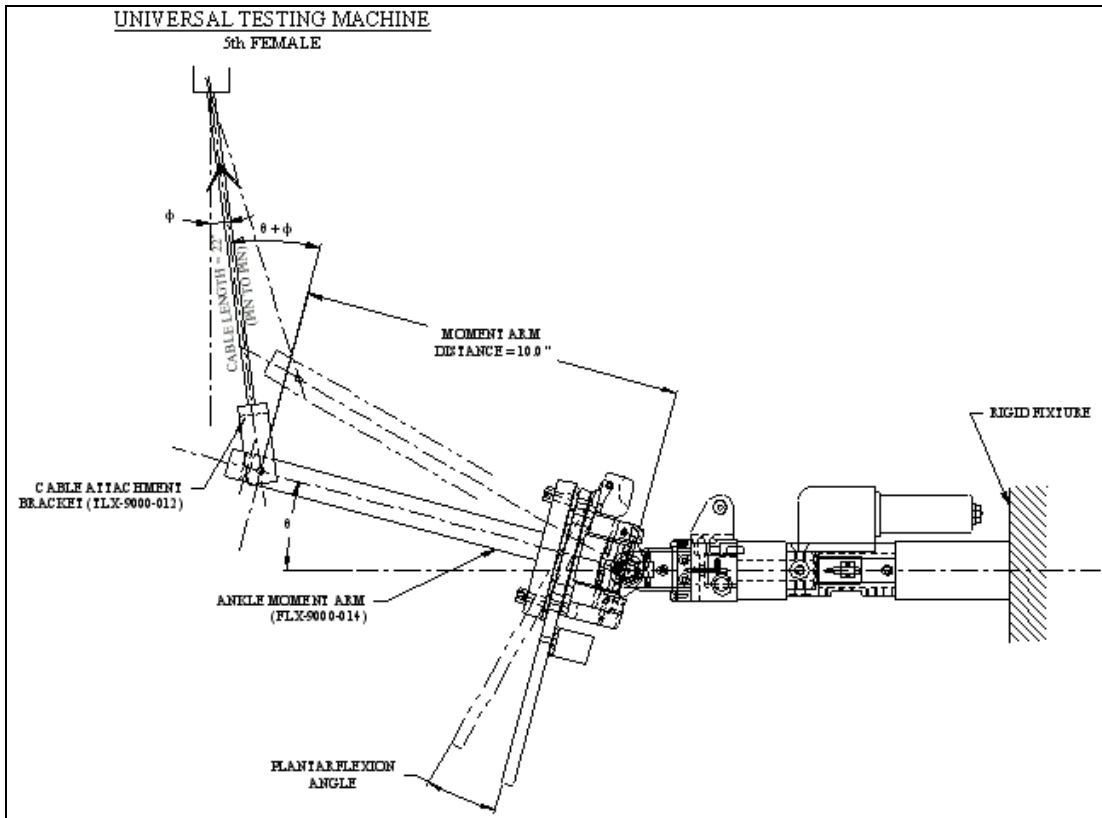

Figure B-3. Quasi-static Plantarflexion Test Setup

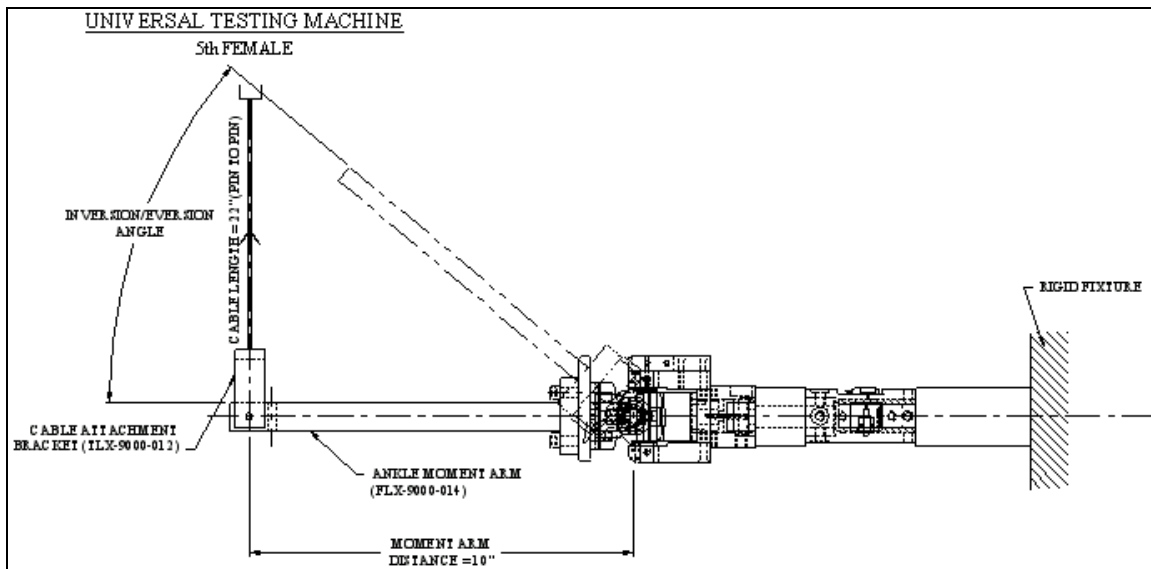

Figure B-4. Quasi-static Inversion/Eversion Test Setup

3. Attach one end of the steel cable to the universal testing machine and the other end to the cable attachment bracket. The length of the cable assembly is 559 mm (22 in).

The pulling cable should be perpendicular to the ankle moment arm at the initial position (rotation angle, equal to  $0^0$ ), but will not remain perpendicular to the ankle moment arm throughout the tests. In order to calculate the torque at the ankle joint, the following variables are defined and illustrated in Figure B-5:

$\phi$  = angle between pulling cable and vertical

$\upsilon$  = rotation angle at ankle pivot

$l$  = length of cable

$a$  = length of moment arm

$P$  = pulling force on cable

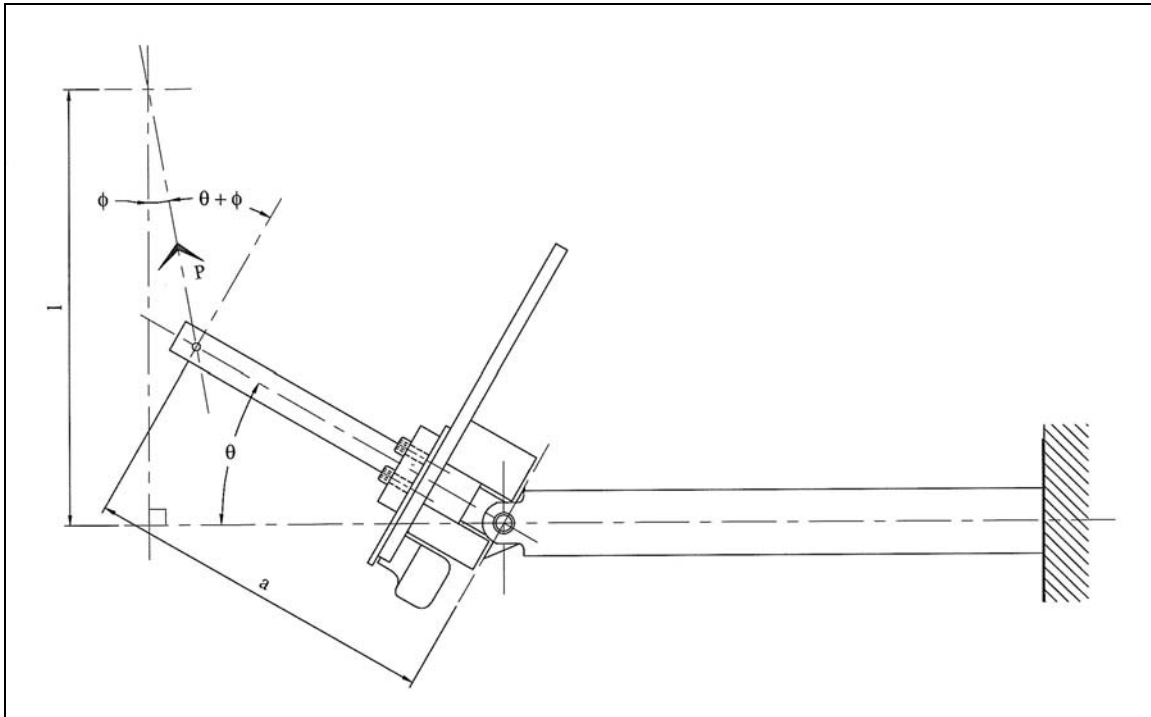

Figure B-5. Geometric Variables for the Quasi-static Tests

The torque at the ankle joint is determined as follows:

$$\phi = \sin^{-1}\left(\frac{a - a \cdot \cos \theta}{l}\right) \quad (\text{Eq. 1})$$

The torque about the ankle joint can then be calculated by:

$$\text{Torque} = P \cdot a \cdot \cos(\theta + \phi) \quad (\text{Eq. 2})$$

In this test setup,  $a = 0.254$  m and  $l = 0.559$  m. Note that the units for torque will be N-m when the pulling force,  $P$ , is given in Newtons and the moment arm length is given in meters. It can also be noted that the cable length,  $l$ , has been selected such that the angle,  $\phi$ , remains small throughout the test and therefore the force,  $P$ , can be taken as the force applied by the universal testing machine.

4. Verify the potentiometer accuracy by following the ankle potentiometer zeroing procedure outlined in Section 4.3 of the main document.
5. Once the foot is oriented in the proper test starting position, zero all instrumentation channels, except for the potentiometers.
6. Pull up on the cable assembly at a rate of 1-2 degrees per second using a moment arm distance of 254 mm until the angle specified in Table B-2 for each test is attained.

Table B-2. Maximum Rotation Angles

| Test Condition     | Maximum Angle (deg) |
|--------------------|---------------------|
| Dorsiflexion       | 42                  |
| Plantarflexion     | 57                  |
| Inversion/Eversion | 38                  |

7. Record all data channels:
  - X-, Y-, and Z-axis Ankle Rotary Potentiometers
  - Displacement
  - Applied load
8. Calculate the ankle torque as described in Step 3.
9. Allow a minimum of 30 minutes between tests with the same leg assembly.

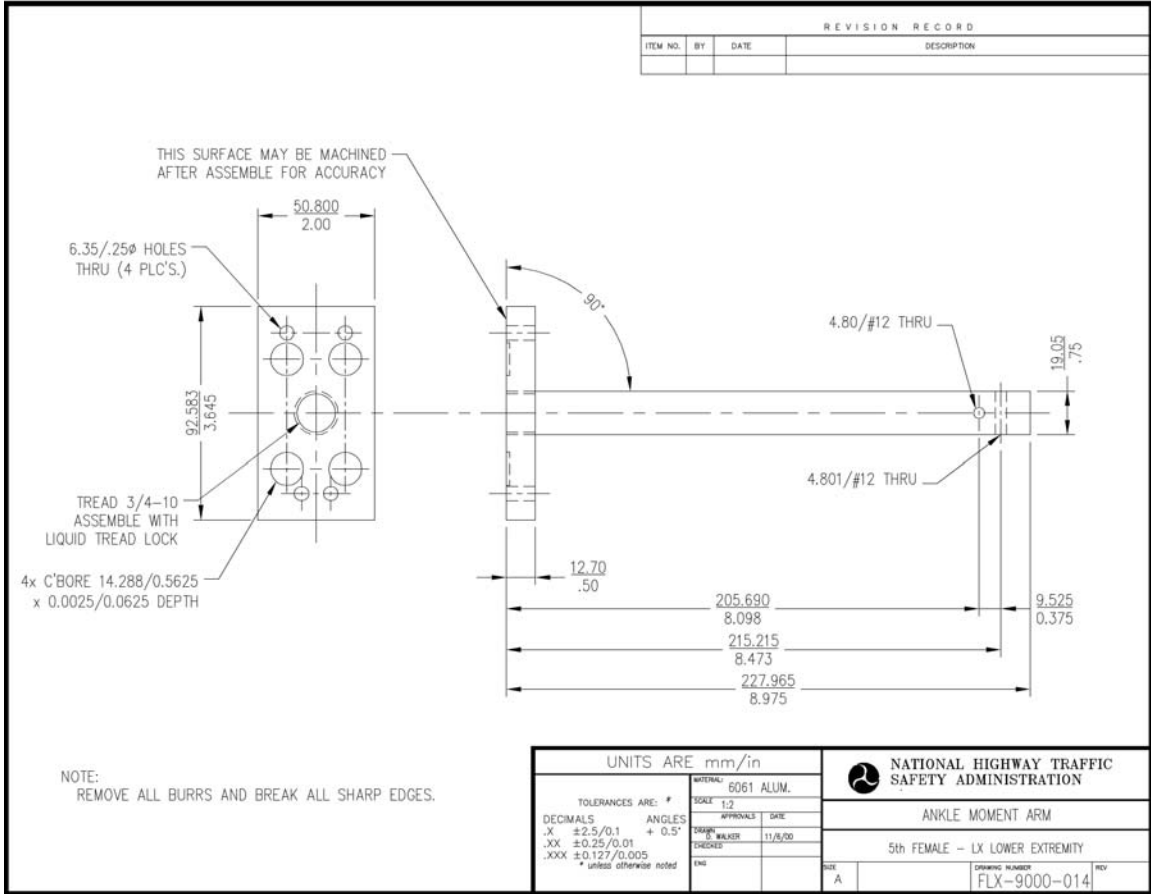

Figure B-6. Ankle Moment Arm for Quasi-static Tests

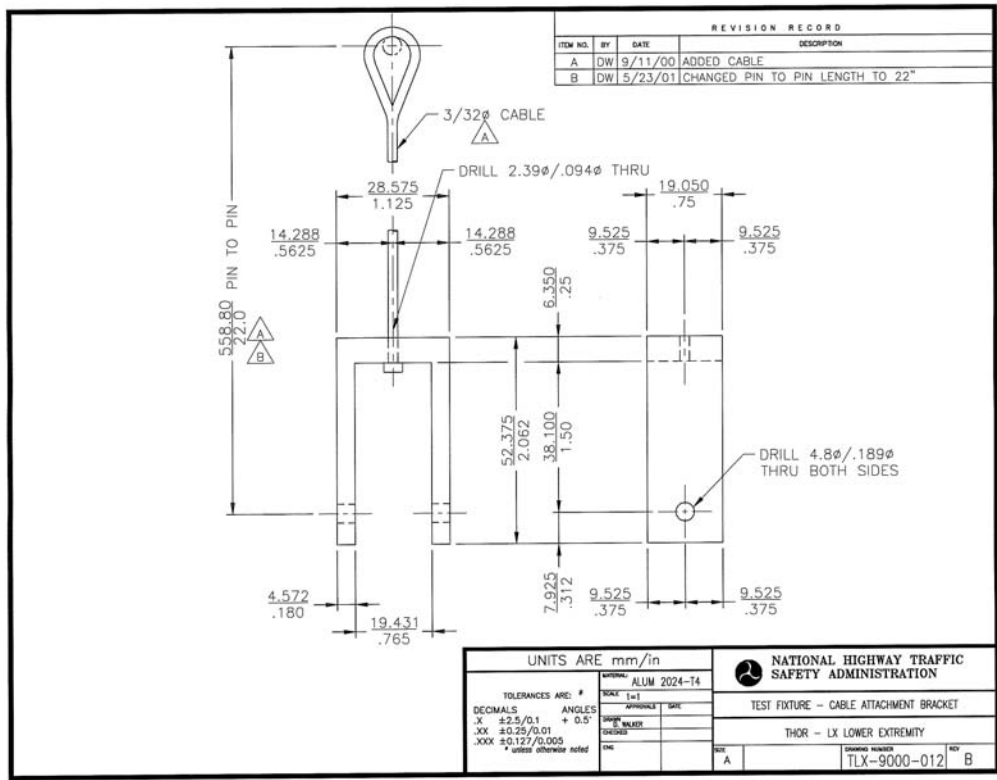

Figure B-7. Cable Attachment Bracket for Quasi-static Tests

## **APPENDIX C. DYNAMIC IMPACT TEST FIXTURES**



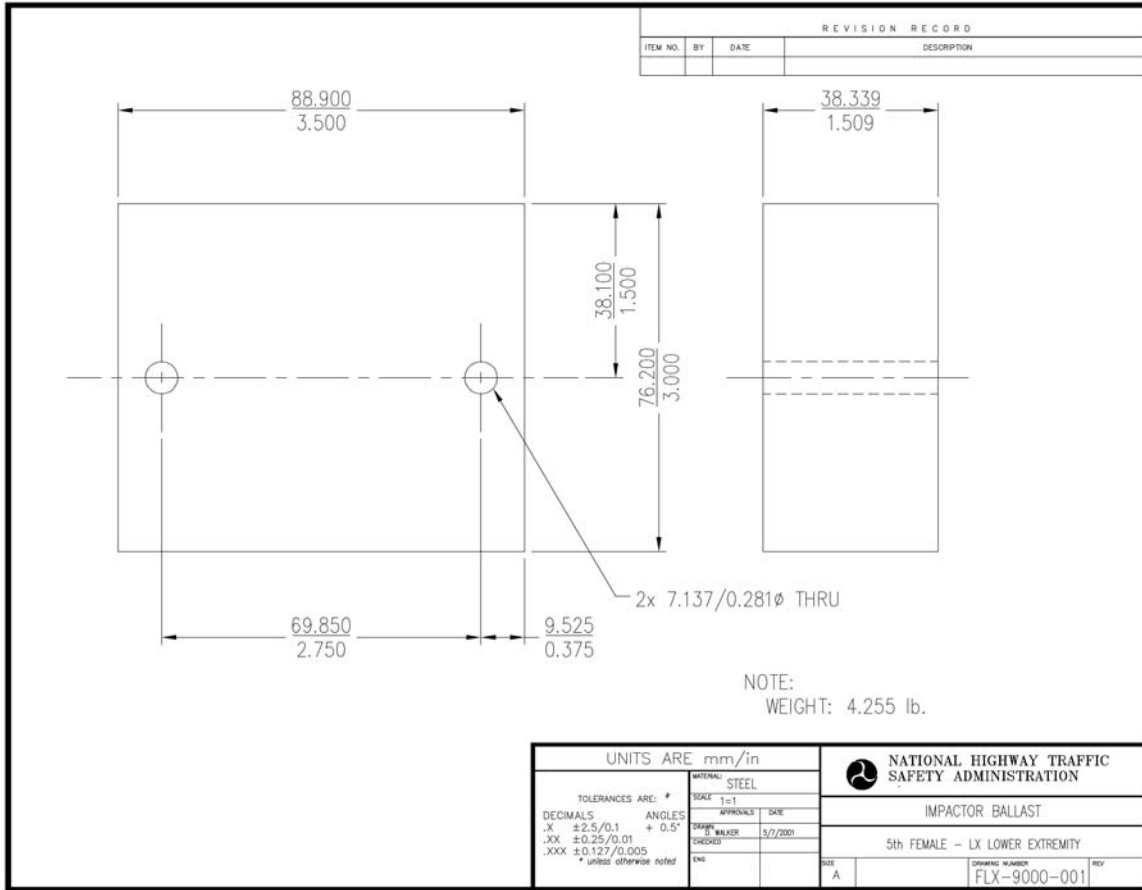

Figure C-1. Dynamic Impactor Ballast

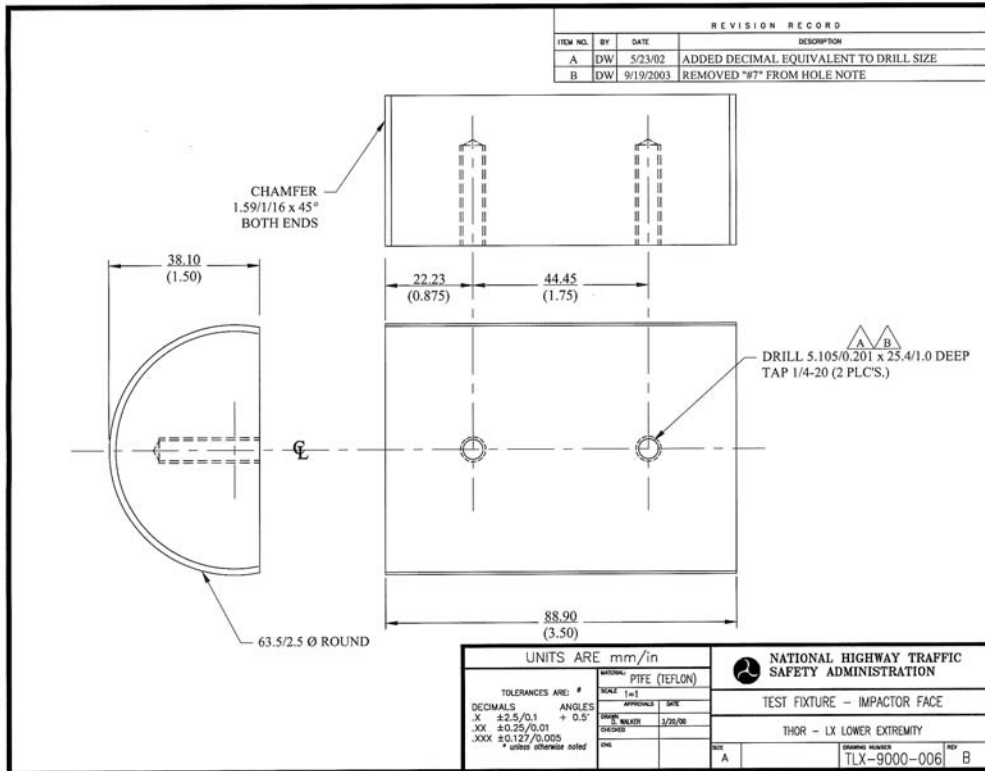

Figure C-2. Dynamic Impactor Face

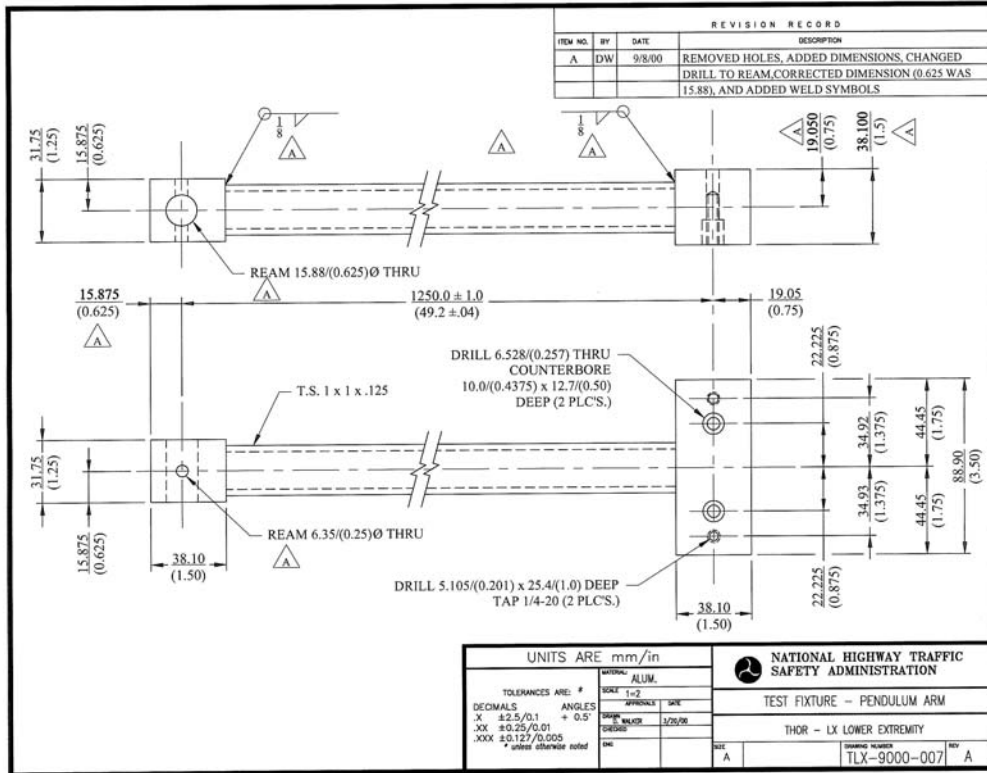

Figure C-3. Dynamic Impactor Pendulum Arm

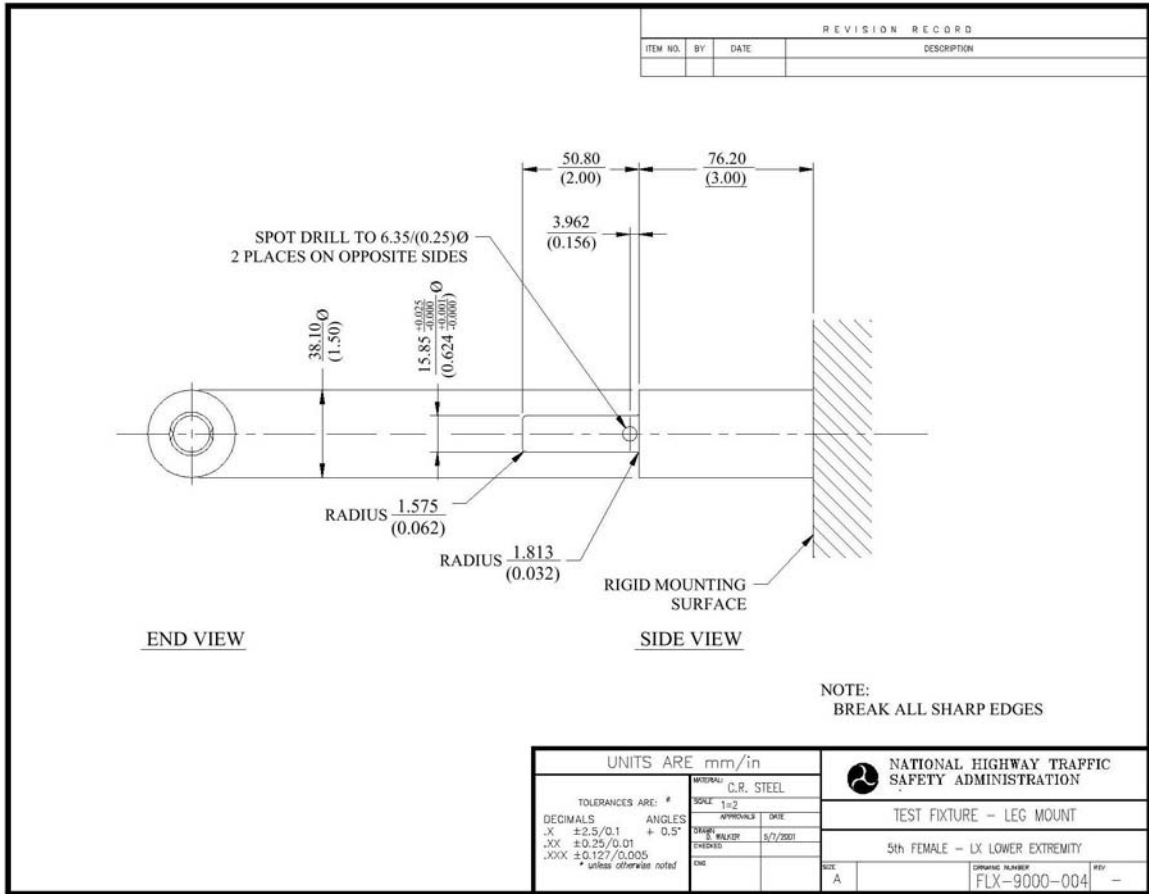

Figure C-4. Tibia Mounting Fixture

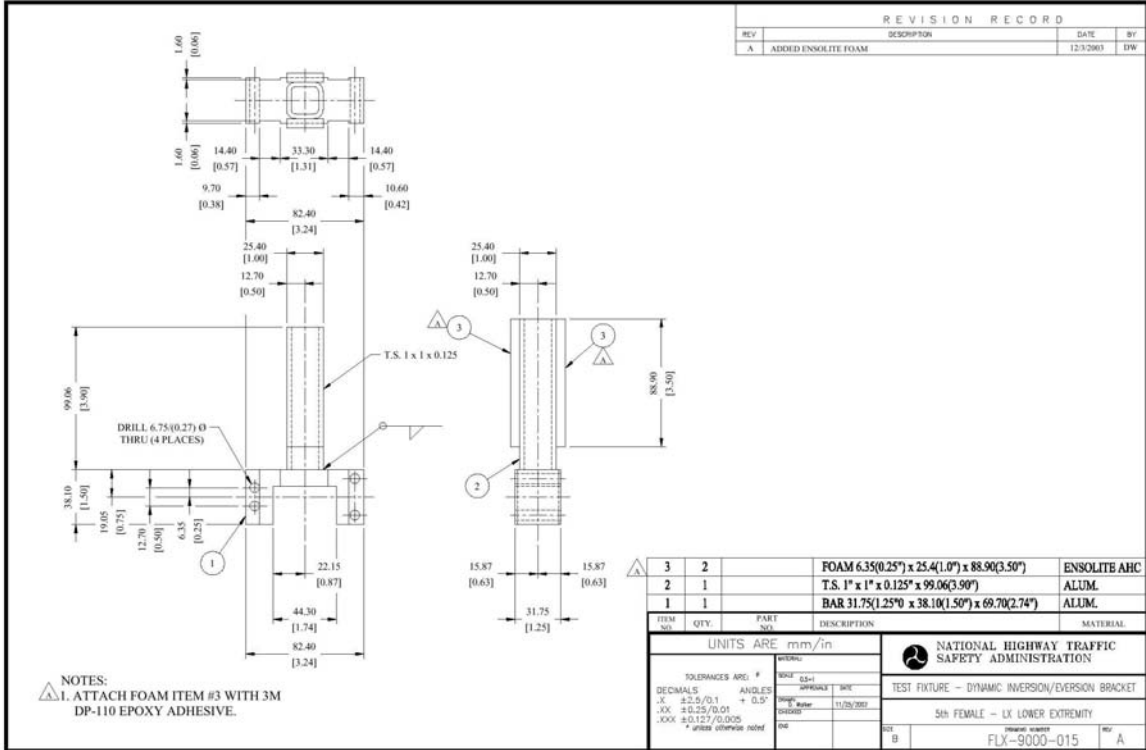

Figure C-5. Dynamic Inversion/Eversion Impact Bracket