

**Bay Area Air Quality Management District**  
939 Ellis Street  
San Francisco, CA 94109

**Workshop Report**

**Proposed Regulation 6, Rule 2 to Control Emissions from  
Commercial Cooking Equipment**

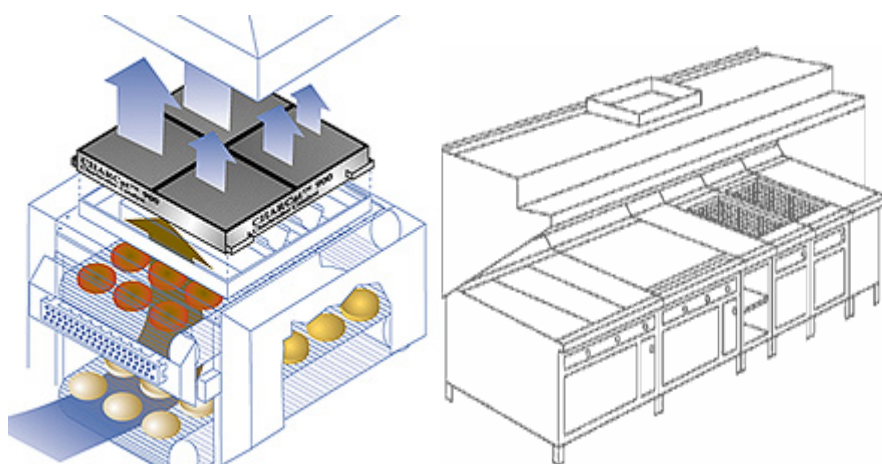

**October 2006**

**Prepared by:**

**Virginia Lau  
Senior Air Quality Specialist  
Planning and Research Division**

## Table of Contents

<b>I.</b>	<b>INTRODUCTION.....</b>	<b>1</b>
<b>II.</b>	<b>BACKGROUND.....</b>	<b>1</b>
	A. Process Description.....	1
	B. Regulatory Background.....	5
<b>III.</b>	<b>TECHNICAL REVIEW .....</b>	<b>6</b>
	A. Emission Inventory .....	6
	B. Evaluation of Potential Controls for Chain-driven Charbroilers.....	8
	C. Evaluation of Potential Controls for Type I Ventilation Hoods .....	10
<b>IV.</b>	<b>PROPOSED RULE BEING CONSIDERED .....</b>	<b>11</b>
	A. Proposed Control of Chain-driven Charbroilers.....	11
	B. Proposed Control of Type I Ventilation Hood .....	12
<b>IV.</b>	<b>RULE DEVELOPMENT / PUBLIC CONSULTATION PROCESS .....</b>	<b>13</b>
<b>V.</b>	<b>REFERENCES.....</b>	<b>13</b>

## **I. INTRODUCTION**

This Workshop Report introduces proposed Bay Area Air Quality Management District (District) Regulation 6, Rule 2: Commercial Cooking Equipment. The purpose of the rule is to control air pollution from restaurant cooking equipment, including charbroilers, griddles, and fryers.

Restaurants vent substantial amounts of particulate matter (PM) and volatile organic compounds (VOCs) into the atmosphere. Every day in the Bay Area, cooking operations collectively (commercial and non-commercial) emit an estimated 3.35 tons of PM and 1.32 tons of VOC.

Currently, no District rule directly regulates emissions from restaurants. The District is considering the adoption of Regulation 6, Rule 2 to fulfill a commitment proposed in its Senate Bill (SB) 656 Particulate Matter Implementation Schedule. In addition, Further Study Measure (FS) 3 in the District's 2005 Ozone Strategy proposes evaluation of a rule for commercial charbroilers.

Subject to certain limited exceptions, the proposed rule would: (1) require installation of catalytic oxidizers, or equivalent control devices, on all chain-driven charbroilers; (2) prohibit the sale, offer for sale, or installation of Type I hood filters other than high-efficiency filters; (3) require the installation of high-efficiency filters into the existing ventilation hood system, upon replacement of a Type I hood or an exhaust fan that serves a Type I hood; (4) require restaurants that operate under-fired charbroilers with a total grill surface area greater than or equal to 10 square feet to exhaust their emissions through high-efficiency filters within two (2) years of rule adoption; (5) require registration, minimal record keeping, and, for chain-driven charbroilers, maintenance logs of the installed control device. This Workshop Report presents an overview of the proposed Regulation 6, Rule 2 as a means to solicit comments from the public on this proposal.

## **II. BACKGROUND**

### **A. Process Description**

Commercial cooking equipment generates grease, smoke, heat, water vapor, and combustion products. A typical kitchen ventilation system includes an exhaust hood, ductwork, and fan system that extracts heat and pollutants and captures grease using filters, extraction baffles, or water mist systems. As shown in Figure 1, the cooking plume rises through the filters aided by the suction of the exhaust fan, located in most cases on the roof of the restaurant. Large particulates are generally captured in the filters while additional particulates condense in the duct work or in the exhaust fan.

Figure 1. Profile and Cross Sectional Views of Type I Kitchen Ventilation Hood

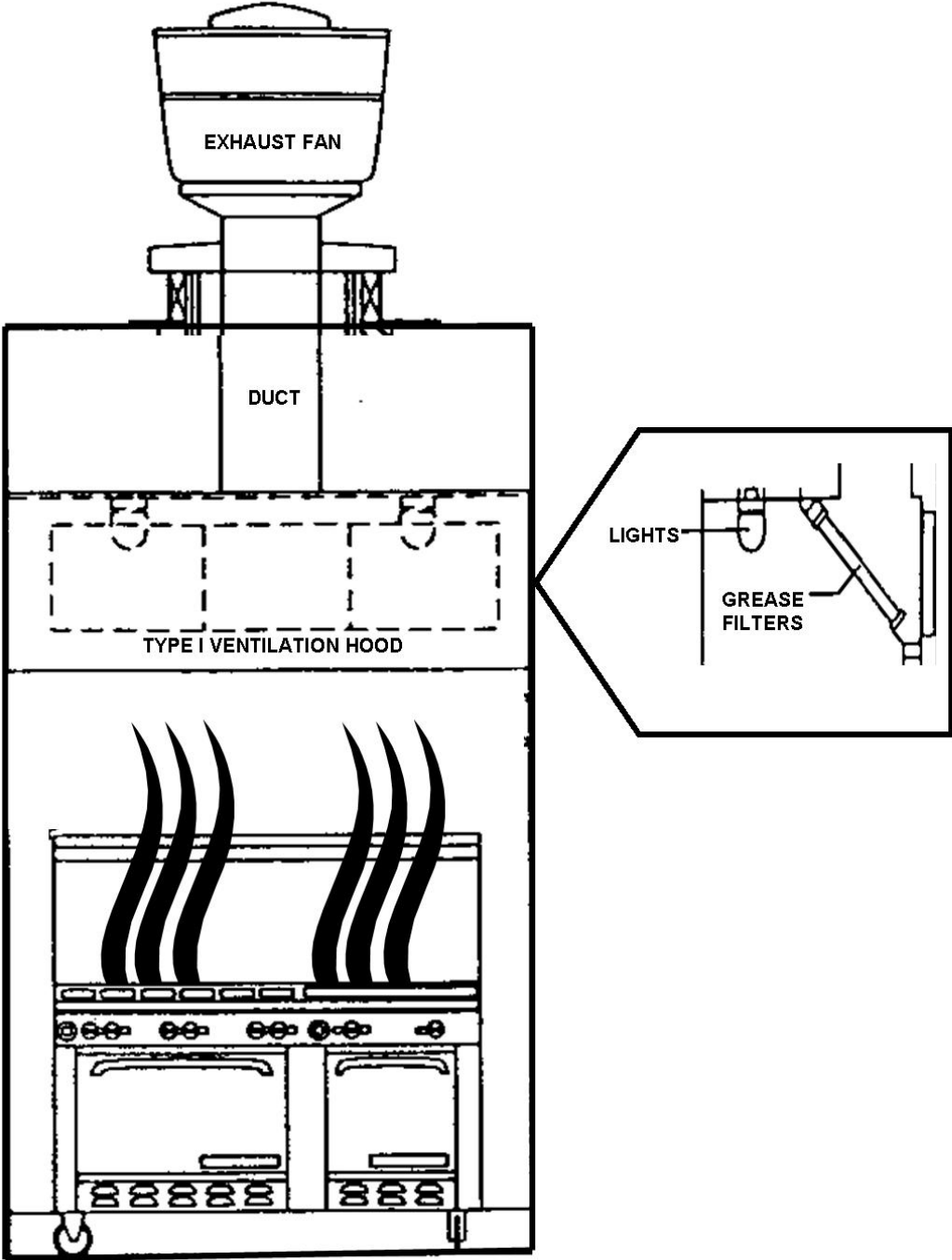

California building codes require that all restaurant hoods must either meet Type I or Type II hood specifications. Cooking operations that produce smoke or grease require the installation of Type I hoods, which are liquid tight and have built-in fire suppression systems. Any restaurant that operates a charbroiler, range, wok, griddle, fryer, rotisserie, or oven is required to install a Type I hood. Type II hoods are allowed to vent exhaust containing only steam, vapor, heat, and odors, but not grease or smoke. Typically, Type II hoods only exhaust emissions from cheesemelters, pastry ovens, steamers, kettles, or dishwashers. The standards specified in Regulation 6, Rule 2 apply directly to Type I hoods, Type I hood filters, and charbroilers.

The proposed rule aims to reduce emissions from restaurant cooking equipment, including charbroilers, griddles, and deep fat fryers. The discussion that follows describes these cooking appliances.

Charbroilers are a central appliance for most restaurant kitchens and are used to cook steak, hamburgers, fish, chicken, and seafood as well as to brown food and to reheat plated food. Charbroilers are composed of a grated grill and a heat source, where food resting on the grated grill cooks as the food receives heat either directly from the heat source, or indirectly by way of a radiant surface.

Two types of charbroilers, chain-driven and under-fired, have been evaluated. A chain-driven (conveyorized) charbroiler is a semi-enclosed broiler designed to move food mechanically on a grated grill through the device as the food cooks. Food cooks quickly, because chain-driven charbroilers have burners located both above and below the grill. Chain-driven charbroilers are most common in fast food restaurants.

In an under-fired charbroiler, the heat source is positioned at or below the level of the grated grill. Designs of under-fired charbroilers vary widely. Some under-fired broilers use charcoal or wood for fuel, but more often, the broilers are fueled by gas or electricity. In gas under-fired charbroilers, a radiant surface, such as a bed of ceramic briquettes or a metal shield, placed above the burners diffuses heat from the burners. (See Figure 2.) The heating elements of electric charbroilers are often either interwoven with, or sheathed inside, the grill. Under-fired charbroilers are common in fine dining and casual restaurants. Figure 3 presents examples of chain-driven and under-fired charbroilers.

Griddles are used throughout the retail food industry to crisp and brown food as well as for searing and cooking hamburgers, chicken, steak, and fish. Griddles vary in size, power input, heating method, and griddle-plate construction. Figure 4 presents examples of two types of griddles. Griddles cook food through direct contact with a heated metal plate. The plate is heated from underneath by gas burners or electric elements, and the heat is adjusted using controls on the front

**Figure 2. Diagram of Under-Fired Charbroiler**

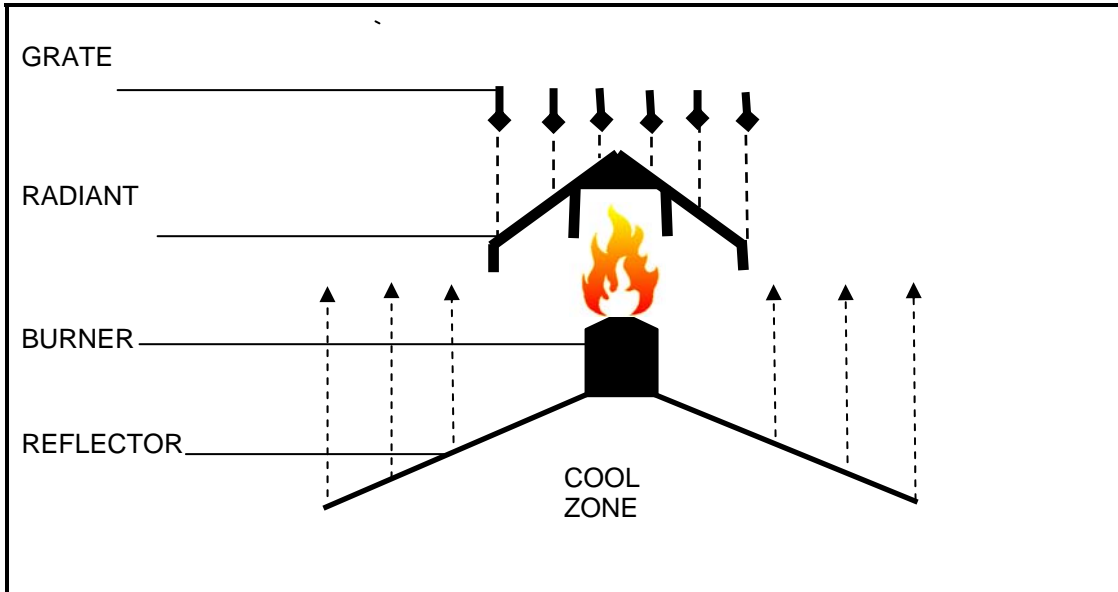

Source: Vulcan-Hart Company

**Figure 3. Examples of Chain-driven Broiler (left) and Under-Fired Broiler (right)**



Sources: Nieco and Magikitch'n

of the appliance. The plates are designed with splashguards on the sides and rear of the plates. A shallow trough in front of the plate collects grease and scraps.

Deep fat fryers are also commonly used in fast food establishments and family style restaurants. Fryers use an exposed hot metal surface to heat cooking oil. The food is cooked by immersion in the hot oil. Moisture from the food vaporizes during the cooking process, generating PM and VOCs.

**Figure 4. Examples of Single-sided Griddle (left) and Countertop Griddle (right)**



Sources: AccuTemp Products, Inc.

## **B. Regulatory Background**

The District is considering Regulation 6, Rule 2, in accordance with the District's SB 656 Particulate Matter Implementation Schedule and in connection with FS 3 in the District's 2005 Ozone Strategy, as a means to reduce restaurant emissions of PM and VOCs in the Bay Area. VOCs are ozone precursors, and also contribute to indirect or secondary PM.

SB 656 requires that all air districts in California adopt an implementation schedule that prioritizes appropriate measures for reducing PM emissions. The District's Particulate Matter Implementation Schedule proposes to adopt Regulation 6, Rule 2 as a measure to reduce direct and indirect PM emissions in the Bay Area.

Under FS 3, the District proposed to examine the feasibility of reducing ozone precursor emissions from restaurants. FS 3 was part of the District's 2005 Ozone Strategy, directed toward attainment of the State one-hour ozone standard.

Currently, no District rule directly regulates the emissions of air pollutants from restaurants. However, restaurants in the Bay Area must nonetheless comply with District regulations of general applicability, such as Regulation 6: Particulate Matter and Visible Emissions, and Regulation 7: Odorous Substances.

At present, the South Coast Air Quality Management District (SCAQMD), the San Joaquin Valley Unified Air Pollution Control District, and the Ventura County Air Pollution Control District have each adopted a rule that limits emissions from restaurant charbroilers. Each of these rules requires chain-driven charbroilers to operate with a control device to limit the emissions of VOCs and PM.

In addition, restaurants in the Bay Area must ventilate their kitchens with systems that comply with certain State and local fire safety requirements. Although the primary focus of these requirements is not air quality, the requirements govern the operation and maintenance of the same equipment addressed in proposed Regulation 6, Rule 2.

### **III. TECHNICAL REVIEW**

#### **A. Emission Inventory**

Most cooking appliances such as charbroilers, griddles, and fryers produce air pollutants through combustion. The air pollutants are primarily generated from incomplete combustion of grease and meat additives, such as tenderizers and marinade. The air contaminants are released when grease and meat additives fall onto the heat source, radiant surface, or hot plate, or when grease flares in the drip tray or bubbles at the surface.

The smoke and vapors generated from the process contain VOCs and PM that consist of aldehydes, organic acids, alcohol, nitrogen and sulfur compounds, and polycyclic aromatic hydrocarbons (PAHs). VOCs react with other compounds in the atmosphere to form ground-level ozone, commonly called smog. PM consists of airborne particles. PM can be emitted directly and also can be formed in the atmosphere through chemical reactions between other pollutants, including VOCs. Cooking emissions include fine particles that are equal to or less than 10 microns in diameter, commonly referred to as PM<sub>10</sub>. PM<sub>10</sub> generated by cooking appliances passes through the ventilation system and is exhausted into the atmosphere.

Both VOCs and PM<sub>10</sub> present public health risks. Ozone produced from chemical reactions involving VOCs may damage lung tissues and the respiratory tract. Once inhaled, PM<sub>10</sub> may become lodged in the respiratory tract and lead to wheezing, nose and throat irritation, bronchitis, and lung damage.

To date, only emissions from charbroilers, griddles, and fryers have been studied extensively. SCAQMD and the California Air Resources Board (CARB) sponsored several studies in order to determine the percentage of restaurants that use these cooking appliances, the amount and type of meat cooked on each of the appliances, and the amount of PM<sub>10</sub> and VOCs produced from meat cooked on these appliances. The District relied on these research studies, and on information provided by the health department of each of the nine Bay Area counties, to estimate the amount of PM<sub>10</sub> and VOCs emitted from restaurant charbroilers, griddles, and fryers in the Bay Area.

District staff estimated the number of restaurants in operation in the Bay Area with assistance from the health department of each county in the District. Each county health department provided the District with the number of restaurants permitted within the county's jurisdiction. District staff refined the number of



restaurants by eliminating the establishments that are not open to the public or that have gone out of business, as well as those that are less likely to cook, for instance, ice cream parlors and delicatessens.

To estimate the number of charbroilers, griddles, and fryers used in Bay Area restaurants, the District consulted the 1997 SCAQMD report, Staff Recommendations Regarding Controlling Emissions from Restaurant Operations. The SCAQMD report surveyed the type of equipment that was used in restaurant cooking operations in Southern California. The report found that approximately 33% of restaurants operate under-fired charbroilers, 4% operate chain-driven broilers, 52% operate griddles, and 62% operate deep fat fryers. Based on these percentages, the District estimates that approximately 4,897 Bay Area restaurants operate under-fired charbroilers, 554 operate chain-driven charbroilers, 7,715 operate griddles, and 9,126 operate deep fat fryers.

The District used several studies to estimate the amount of meat cooked on these appliances and their associated emissions due to cooking. The District relied on data developed for CARB by the Public Research Institute pertaining to the average amount of meat cooked on each type of appliance. Emission factors developed by the University of California Riverside (UCR) and University of Minnesota were used to quantify average emissions from each type of meat cooked on charbroilers, griddles, and deep fat fryers. The estimated emissions of VOC and PM<sub>10</sub> by type of appliance are shown in Table 1.

**Table 1. Emissions from Commercial Restaurant Appliances in the Bay Area**

Type of Food	Chain-driven Charbroiler		Under-fired Charbroiler		Griddles		Deep Fat Fryer	
	PM <sub>10</sub> *	VOC	PM <sub>10</sub>	VOC	PM <sub>10</sub>	VOC	PM <sub>10</sub>	VOC
Hamburger	85.3	26.1	327	135	94.5	5.09	6.52	0
Steak	25.2	7.72	286	118	43.3	2.33	4.31	0
Poultry without Skin	15.7	4.81	37.5	34.1	22.9	7.06	8.65	10.4
Poultry with Skin	28.5	8.70	67.8	61.7	28.9	8.90	4.93	5.92
Pork	6.16	1.88	14.7	13.3	29.1	8.96	1.39	1.67
Seafood	12.7	3.89	49.9	5.75	24.0	7.39	3.76	5.27
Potatoes	---	---	---	---	---	---	6.50	13.7
<b>Total Emissions (tons/year)</b>	<b>174</b>	<b>53</b>	<b>782</b>	<b>369</b>	<b>243</b>	<b>40</b>	<b>36</b>	<b>23</b>
<b>Total Emissions (tons/day)</b>	<b>0.48</b>	<b>0.15</b>	<b>2.1</b>	<b>1.0</b>	<b>0.67</b>	<b>0.11</b>	<b>0.10</b>	<b>0.06</b>

Notes: \*: PM10 concentrations include condensable vapor emissions.

'---': not applicable

Besides VOCs and PM emissions, cooking operations also produce carbon dioxide (CO<sub>2</sub>), a gas contributing to climate change. In 2005, the District adopted a Climate Protection Program aimed at reducing greenhouse gas emissions. A University of Minnesota study found that most of the CO<sub>2</sub> emissions were generated from gas charbroilers. In addition to combustion of natural gas, CO<sub>2</sub> is produced when grease drippings combust on hot radiant surfaces. The District estimates that the average CO<sub>2</sub> emissions for cooking activities per restaurant are approximately 25,000 lbs of CO<sub>2</sub> annually based on operation of the cooking appliances and energy usage<sup>1</sup>.

## **B. Evaluation of Potential Controls for Chain-driven Charbroilers**

Regulation 6, Rule 2 proposes to require that emissions from chain-driven charbroilers be abated.

In evaluating control devices for reducing emissions of VOCs and PM<sub>10</sub> from chain-driven charbroilers, the District consulted studies conducted by SCAQMD, and staff reports from SCAQMD, the San Joaquin Valley Unified Air Pollution Control District, and the Ventura County Air Pollution Control District. The SCAQMD studies evaluated potential controls for reducing PM<sub>10</sub> and VOC emissions from commercial charbroilers. The three air district staff reports examined the feasibility of employing the following controls: catalytic oxidizers, fiber-bed filters, incinerators (catalytic and thermal), electrostatic precipitators, and wet scrubbers. Using the cost estimates provided in the SCAQMD Staff Report, the District estimated the total annual costs, amortized over a ten-year period, of installing each control technology and operating it for a period of ten years in the Bay Area. The following discussion describes each technology that was evaluated, the costs for installing and maintaining the control, and the removal efficiency of the technology.

A catalytic oxidizer is a device used for flameless incineration. Fitted to the top of a chain-driven charbroiler, it burns grease and gases from the cooking process, turning them into carbon dioxide and water. Heat from the cooking process activates the device such that an external fuel source is not required. The District estimates that the total annualized cost to install and maintain the operation of the device over a ten-year period is approximately \$2,028. Assuming an overall removal efficiency of 83%, the District estimates emission reductions of both PM<sub>10</sub> and VOC combined of 190 tons per year (tpy) or 0.53 tons per day (tpd) (0.40 tpd of PM<sub>10</sub> and 0.13 tpd of VOC) would result if all existing chain-driven charbroilers were equipped with catalytic oxidizers.

In fiber-bed filters, the exhaust stream flows horizontally through an enclosed filter bed where particles are captured by the fibers of the filters. Particles coalesce on the filter surface while clean gas exits from the opposite side of the

---

<sup>1</sup> Electricity and gas usage only accounts for the operation of the cooking appliances, but does not include utilities required to power the air conditioning and heating systems, refrigeration units, make-up air, lights, and other types of equipment.

filter. The District estimates that the total amortized annual costs of installing and operating a fiber-bed filtration system over a ten-year period are \$9,024. Though fiber-bed filters remove PM<sub>10</sub> from an exhaust stream, they do not remove VOC. The District estimates PM<sub>10</sub> emission reductions to be 157 tpy (0.43 tpd), based on an estimated 90% removal efficiency if fiber bed filters were installed in all existing chain-driven charbroilers. Because a fiber-bed filter removes only PM<sub>10</sub> and not VOC, it would achieve a lower total PM and VOC emission reduction, at a higher amortized annual cost, than a catalytic oxidizer.

Thermal incineration is one of the most common methods used to remove PM<sub>10</sub> and VOC from an air stream. This method oxidizes both PM<sub>10</sub> and VOC at high temperatures, converting the air pollutants into carbon dioxide and water. Assuming a combined removal efficiency of 95% for PM<sub>10</sub> and VOC, the District estimates emission reductions of both pollutants would total 216 tpy (0.60 tpd) from all existing chain-driven charbroilers. The District estimates that the total annualized cost to install, operate, and maintain an incinerator over a ten-year period is \$99,209. Much of the cost associated with a thermal incinerator results from the large amount of fuel required to operate the device.

Electrostatic precipitators (ESPs) have been used for the last 60 years in many industries to remove PM<sub>10</sub> from an exhaust stream. An ESP functions by screening out gross PM with a pre-filter, and then inducing an electrostatic charge in the particles remaining in the exhaust stream. The charged particles attach to an oppositely charged electrode, from which they are later removed. The District estimates that the amortized annual cost to install, maintain, and operate an ESP over a ten-year period is approximately \$6,544. The District estimates the Bay Area would realize emission reductions of 157 tpy (0.43 tpd) of PM<sub>10</sub> if all existing chain-driven charbroilers were abated by an ESP, assuming a 90% removal efficiency. However, an ESP will not remove VOC from an exhaust stream. Thus, an ESP unit would achieve lower emission reductions at a higher capital and recurring cost than a catalytic oxidizer. Also, ESP units require extensive maintenance and frequent cleaning to ensure optimum performance. A unit that is not properly cleaned may become a fire hazard.

Wet scrubbers rely on a finely atomized stream of water to capture particulate from an exhaust stream. A packed scrubber is a tower where an exhaust stream enters from the bottom of the tower and the scrubbed stream flows out of the top. The District estimates that the total amortized annual cost to operate a wet scrubber over a ten-year period is \$4,130. However, this cost estimate does not include the additional expense of disposing of, or reusing, the liquid waste generated by scrubbers. The District estimates reduction of 157 tpy (0.43 tpd) of PM<sub>10</sub> if all existing chain-driven charbroilers were abated by a wet scrubber, assuming a 90% removal efficiency. A wet scrubber would not remove VOC from an exhaust stream. As a result, a wet scrubber would achieve a lower total emission reduction, at a higher amortized annual cost, than a catalytic oxidizer.

### **C. Evaluation of Potential Controls for Type I Ventilation Hoods**

In evaluating potential controls for Type I hoods, the District consulted two University of California, Riverside (UCR) studies that evaluated both experimental and conventional control technologies for use on under-fired charbroilers and considered conclusions the South Coast Air Quality Management District (SCAQMD) reached based upon the UCR studies, as well as on the studies referenced in the previous section of this workshop report.

The UCR studies evaluated the potential of several technologies for installation into restaurant kitchen exhaust systems to control restaurant cooking emissions. These technologies included ultraviolet hoods, microwave ceramic filters, and cyclonic air scrubbers.

The UCR studies concluded that each technology had significant limitations. The ultraviolet lamps in the hoods became coated with grease, which rendered them unable to oxidize air contaminants as they were designed. The ceramic filter suffered from numerous mechanical difficulties and realized a low overall VOC removal. Similarly, the cyclonic air scrubber suffered from low VOC removal efficiency and high operating costs.

Based on the UCR findings, the District decided to examine another control option that SCAQMD and UCR did not evaluate: high-efficiency filters. High-efficiency multi-stage filters are comprised of a high-performance baffle filter that is joined with a second filter filled with a tightly packed bed of porous ceramic beads. High-efficiency filters are made to be compatible with most Type I hoods, the same category of hood through which the California building codes require all restaurant grease emissions to be exhausted.

For costing purposes, District staff estimated the cost of installing high-efficiency filters in new ventilation hoods and retrofitting into an existing ventilation hood. For an existing hood, the District assumed that the high-efficiency filter would be installed upon replacement of the exhaust fan. Similarly, new kitchen constructions were assumed to include installation of high-efficiency filters and compatible equipment such as an exhaust fan at the time of construction.

The District estimates that the total amortized annual costs over a ten-year period for installing high-efficiency filters in new kitchen constructions and retrofitting into existing kitchens at the time the exhaust fan is replaced ranges from \$979 to \$1,156. Costs include installation of the high-efficiency filters and an exhaust fan for a typical kitchen layout that consists of a three foot gas charbroiler, two foot griddle and one foot deep fat fryer.

The District estimates a PM<sub>10</sub> emission reduction of 212 tpy (0.58 tpd), based on an average 20% removal efficiency, if all existing restaurants with under-fired charbroilers, griddles, and fryers installed high-efficiency filters. The 20%

removal efficiency was determined based on performance tests conducted by two manufacturers following the American Society of Heating, Refrigeration, and Air Conditioning Engineers (ASHRAE) Standard 52.2. High-efficiency filters do not capture VOCs.

For commercial restaurants that operate under-fired charbroilers with total grill surface area greater than or equal to 10 square feet, the District evaluated the feasibility of retrofitting their existing ventilation hoods with high-efficiency filters prior to replacement of the exhaust fan. Because of the larger charbroiler size, the District believes that these restaurants are likely contributing a disproportionate amount of PM emissions associated with commercial cooking.

The District estimates that the total amortized annual costs over a ten-year period for installing high-efficiency filters in existing kitchens with under-fired charbroilers with a total grill surface area greater than or equal to 10 square feet (prior to the regular replacement of the exhaust fan) ranges from \$1,621 - \$1,941. Costs include installation of the high-efficiency filters and exhaust fan<sup>2</sup>, crane rental, and increased utility usage. The District estimates PM<sub>10</sub> emission reductions of 78 tpy (0.21 tpd), based on an average 20% removal efficiency.

Finally, the District acknowledges that high-efficiency filters are available only for Type I hoods using baffle filters, and not those using fixed extractors or cartridge filters. The District also notes that high-efficiency filters require a more powerful exhaust fan which results in higher power usage. Additional CO<sub>2</sub> is generated by power plants in order to produce the energy required to run the higher power exhaust fan. The District staff estimated that approximately 6,500 pounds of additional CO<sub>2</sub> is produced per year for each restaurant that installs high-efficiency filters<sup>3</sup>.

## **IV. PROPOSED RULE BEING CONSIDERED**

### **A. Proposed Control of Chain-driven Charbroilers**

Based on the technical evaluation, the District is proposing to require that all existing chain-driven charbroilers be equipped with a catalytic oxidizer. The restaurant owner may install an equivalent control as long as the owner demonstrates with a source test that the charbroiler, when operated with the control, will emit less than 1.0 pound of total PM per 1,000 pounds of meat

---

<sup>2</sup> High-efficiency filters require a greater fan capacity. To attain a higher efficiency, high-efficiency filters have a greater resistance to airflow such that the pressure difference between upstream and downstream sides of the filter is greater than using conventional baffle filters. A higher capacity fan system is required to compensate for the increased pressure drop. The cost of installing a higher powered exhaust fan is included in the District cost estimate.

<sup>3</sup> Additional energy usage was estimated by inputting the specific exhaust rate, pressure drop, and fan type for a San Francisco-based operation into PG&E Outdoor Air Load Calculator, located at [www.archenergy.com/oac/oac.html](http://www.archenergy.com/oac/oac.html).

cooked. The restaurant owner is required to operate the charbroiler with the control and to maintain any control device required under the rule in good working order and in accordance with the recommendations of the manufacturer. An existing restaurant that has a control device permitted by the District prior to adoption of the rule may conduct a source test of their control device and submit their results to determine whether the control is operating in compliance with the proposed Regulation 6, Rule 2.

Restaurant owners would be required to register their chain-driven charbroiler with the District within one year of adoption on this rule, but are not required to obtain a permit. The District is developing a web based registration system. The owner will be required to pay a one time registration fee in addition to an annual fee for continued registration. Owners must also maintain records of the installation of, and maintenance and cleaning performed on, the control device. Finally, restaurant owners required to register any equipment would be required to notify the District of any change in ownership of the restaurant in which the registered equipment is operated.

#### **B. Proposed Control of Type I Ventilation Hood**

The District proposes to phase high-efficiency filters into use in the Bay Area over time. Effective six months after adoption, and subject to an exemption for water wash hoods or ventilation systems that use cartridge filters, the proposed rule would prohibit the sale, offer for sale, and installation of Type I hood filter other than high-efficiency filters. Restaurants would be required to install high-efficiency filters upon replacement of a Type I hood or an exhaust fan that serves a Type I hood.

Moreover, restaurant owners with one or more under-fired charbroilers with a total grill surface area greater than or equal to 10 square feet would be required to install high-efficiency filters in a Type I hood operated in the restaurant within two (2) years of adoption of this rule. The owners will also be required to register each under-fired charbroiler in the restaurant on the District web site. Owners will be assessed a one time registration fee in addition to an annual fee for continued registration.

The rule will require filters to be maintained in good working order and in accordance with the recommendations of the manufacturer.

The owner or operator of an under-fired charbroiler less than 10 square feet or other types of cooking equipment will not be required to register with the District. Instead, the District will receive an annual listing of newly constructed restaurants from each of the nine Bay Area county health departments. Using the list provided by the counties, the District may inspect any of the restaurants to ensure compliance with this proposed regulation. Initial inspection of the restaurants during construction may be conducted by the county building and/or health departments as part of their routine inspections to ensure that the proper

filters have been installed into the ventilation system.

Restaurant owners and operators would be required to maintain the contract under which any Type I hood, exhaust fan serving a Type I hood, or high-efficiency filter was purchased and installed, and a record of the date of initial installation of the high-efficiency filters. Restaurant owners required to register any equipment would also be required to notify the District of any change in ownership of the restaurant in which the registered equipment is operated.

#### **IV. RULE DEVELOPMENT / PUBLIC CONSULTATION PROCESS**

This Report and associated Public Workshop is the latest step in the District's consultation process with county health departments, industry, trade organizations, and the public as the District considers Regulation 6, Rule 2: Commercial Cooking Equipment. Following public workshops, District staff will evaluate comments before presenting a final draft for a public hearing in front of the District Board of Directors.

The District held meetings on January 19, 2006, and July 28, 2006, with representatives from the health departments of each of the nine Bay Area counties to discuss emission estimates, control technologies, and county procedures for permitting and inspecting restaurants. In addition, the District met with the Golden Gate Restaurant Association to discuss the potential impact this proposed regulation may have on the association's members. District staff also had several meetings with representatives from the Pacific Gas and Electric's Food Service Technology Center to discuss possible control options and associated operational costs.

The District also conducted source tests of restaurants operating charbroilers and other cooking appliances to verify emissions estimates and also to verify the proposed method of testing for compliance with the proposed regulation.

The purpose of the Public Workshop(s) is to solicit comments from the public on the proposed new Regulation 6, Rule 2. At the workshop(s), the staff will also respond to questions about information set forth in this Workshop Report. Based on the input staff receives prior to and at the workshop(s), staff will decide whether changes to the proposal are necessary prior to a public hearing before the District's Board of Directors.

#### **V. REFERENCES**

1. Hildemann, L.M., Cass, G.R., Markowski, G.R., 1989. A Dilution Stack Sampler for Collection of Organic Aerosol Emissions: Design, Characterization and Field Tests. *Aerosol Sci. Technol.* 10: 193-204.

2. Gerstler, W.D., Kuehn, T.H., Pui, D.Y., Ramsey, J.W., Doerr, M.P., 1996. Identification and Characterization of Effluents from Various Cooking Appliances and Processes as Related to Optimum Design of Kitchen Ventilation Systems. ASHRAE 745-RP, Phase I, Final Report. Dated June 13, 1996.
3. Gerstler, W.D., Kuehn, T.H., Pui, D.Y., Ramsey, J.W., Rosen, M., Carlson, R.R., and Petersen, S.D., 1999. Identification and Characterization of Effluents from Various Cooking Appliances and Processes as Related to Optimum Design of Kitchen Ventilation Systems. ASHRAE 745-RP, Phase II, Final Report. Dated February 9, 1999.
4. Kuehn, T.H., Olson, B.A., Ramsey, J.W., Friell, J., and Rocklage, J., 2004. Development of a Standard Method of Test for Commercial Kitchen Effluent Grease Removal Systems. Draft Final Report. Reported conducted by the University of Minnesota, Department of Mechanical Engineering, Minneapolis, MN for Nickel-Fisher, Inc. Food Service Technology Center, San Ramon, CA. Dated July 31, 2004.
5. MacDonald, J.D., Zielinska, B., Fujita, E.M., Sagabiel, J.C., Chow, J.C., and Watson, J.G., 2003. Emissions from Charbroiling and Grilling of Chicken and Beef. J. Air & Waste Manage. Assoc. 53: 185-184. February 2003.
6. Pacific Environmental Services, Inc., 1999. Final Report. A Detailed Survey of Restaurant Operations in the South Coast Air Basin. Submitted to South Coast Air Quality Management District on February 5, 1999. Contract No. 98089.
7. Public Research Institute, 2001. Charbroiling Activity Estimation. Prepared for the California Air Resources Board and the California Environmental Protection Agency. Dated June 30, 2001.
8. South Coast Air Quality Management District, 1997. Staff Report for Proposed Rule 1138 – Control of Emissions from Restaurant Operations. Dated October 10, 1997.
9. South Coast Air Quality Management District, 2004. Staff Recommendations Regarding Controlling Emissions from Restaurant Operations. Board Meeting Date: December 3, 2004. Agenda No. 39.
10. University of California Riverside, College of Engineering, Center for Environmental Research and Technology, (CE-CERT) 1999. Development and Demonstration of Emission Control Technologies for Commercial Underfired Broilers. Contract No. 98015, February 1999.
11. University of California Riverside, College of Engineering, Center for Environmental Research and Technology, (CE-CERT) 1997. Further



Development of Emission Test Methods and Development of Emission Factors for Various Commercial Cooking Operations. Contract No. 96027, July 1997.