

R&D 100 AWARD



ENTRY 2007

NOVINT

3D Haptics Technology Software



Sandia
National
Laboratories

Submitting Organization

Tom Anderson
Novint Technologies
4109 Bryan Avenue NW
Albuquerque, NM 87114, USA
505-463-1469 (phone)
866-298-4420 (fax)
tom@novint.com

AFFIRMATION: I affirm that all information submitted as a part of, or supplemental to, this entry is a fair and accurate representation of this product.

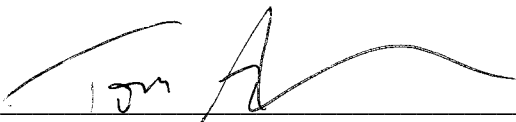
(Signature)  _____

Joint Submitters

Nathan L. Golden
Sandia National Laboratories
P.O. Box 1500
Albuquerque, NM 87185-0114, USA
505-845-9737 (phone)
505-844-8011 (fax)
nlgolde@sandia.gov

Jeff Smith
Lunar Design
541 Eighth Street
San Francisco, CA 94103, USA
415-252-4388 (phone)
415-252-4389 (fax)
info@lunar.com

Joint Submitters

Francois Conti
Force Dimension
PSE-C, CH-1015
Lausanne, Switzerland
41 21 693-1911 (phone)
41 21 693-1910 (fax)
info@forcedimension.com

Product Name

Novint Falcon and Novint/Sandia 3D-Touch Software

Brief Product Description

The Novint Falcon and its 3D-Touch Software lets consumers, for the first time, use an accurate sense of touch in computing.

**Product First Marketed
or Available for Order**

The technology was first available for licensing in March 2006. It was first demonstrated at the 2006 Game Developers Conference.

Inventor or Principal Developers

Tom Anderson, CEO, Novint Technologies
Walt Aviles, CTO, Novint Technologies
Bill Anderson, Director of Game Development, Novint Technologies
Jack Harrod, Hardware Consultant, Novint Technologies
Arthurine Breckenridge, Consultant, Novint Technologies
Richard Aviles, Programmer, Novint Technologies
Jake Jones, Programmer, Novint Technologies
Nick Brown, Programmer, Novint Technologies
Marc Midura, Programmer, Novint Technologies
Daryl Lee, Programmer, Novint Technologies
4109 Bryan Avenue NW
Albuquerque, NM 87114, USA
866-298-4420 (phone)
866-298-4420 (fax)
info@novint.com

Inventor or Principal Developers

George Davidson
Member of the Technical Staff
Sandia National Laboratories
P.O. Box 1500
Albuquerque, NM 87185-1316, USA
505-844-7902
505-845-7442
gsdavid@sandia.gov

Francois Conti
Force Dimension
PSE-C CH-1015
Lausanne, Switzerland
41 21 693-1911 (phone)
41 21 693-1910 (fax)
info@forcedimension.com

Art Sandoval, Lunar Design
Jonathan Downing, Lunar Design
Robert Howard, Lunar Design
Simon Gatrall, Lunar Design
Mike Simmons, Lunar Design
Arturo Meuniot, Lunar Design
Julie Dahlgard, Lunar Design
Jeff Smith, Lunar Design
Jeff Salazar, Lunar Design
Alex Rochat, Lunar Design
James Tsai, Lunar Design
541 Eighth Street
San Francisco, CA 94103, USA
415-252-4388 (phone)
415-252-4389 (fax)
info@lunar.com

Inventor or Principal Developers

Dave Blau

Dave Blau Consulting
12382 South Saratoga-Sunnyvale Road
Saratoga, CA 95070, USA
408-252-7692 (phone)
408-252-7693 (fax)
dave@daveblauconsulting.com

Mark Cutkosky

Stanford University
Department of Mechanical Engineering, Building 530
440 Escondido Mall
Stanford, CA 94305, USA
650-725-1588 (phone)
650-723-3521 (fax)
cutkosky@stanford.edu

Jonathan Karpick

Stanford University
Department of Mechanical Engineering, Building 530
440 Escondido Mall
Stanford, CA 94305, USA
650-725-1588 (phone)
650-723-3521 (fax)
jkarpick@stanford.edu

Product Price

\$189 currently for pre-orders; \$239 MSRP starting at launch on 6/18/07.

Patents and Patents Pending on this Product

Novint and Sandia National Laboratories own over 25 patents/pending patents on this technology.

1. Human-Computer Interface Including Efficient Three-Dimensional Controls. U.S. Patent 6,727,924 issued 4/27/2004.

**Patents and Patents Pending
on this Product**

2. Coordinating Haptics with Visual Images in a Human-Computer Interface. U.S. Patent Application pending.
3. Human-Computer Interfaces Incorporating Haptics. U.S. Provisional Patent Application.
4. Human-Computer Interfaces Incorporating Haptics and Path-Based Interaction. U.S. Patent Application pending.
5. Force Frames in Animation. US Patent application pending.
6. Human-Computer Interface Including Efficient Three-Dimensional Controls. Continuation application of U.S. Patent 6,727,924.
7. Human-Computer Interface Incorporating Personal and Application Domains. U.S. Patent 6,724,400 issued 4/20/2004.
8. Computer Interface Methods and Apparatuses. U.S. Provisional Patent Application.
9. Human-Computer Interface Incorporating Personal and Application Domains. Continuation of U.S. Patent 6,724,400, filed 3/16/2004.
10. Multidimensional Display Controller. U.S. Patent 6,208,349 issued 3/27/2001.
11. Multidimensional Navigational Controller. U.S. Patent Application pending.
12. Human Computer Interfaces. U.S. Provisional Patent Application.
13. Human-computer Interface. U.S. Patent 6,833,826.

Patents and Patents Pending on this Product

14. Human-Computer Interface Incorporating Personal and Application Domains. U.S. Patent 6,724,400 issued 4/20/2004.

15. Human-Computer Interface Incorporating Personal and Application Domains. U.S. Patent Application pending.

16. Human-Computer Interface Including Haptically Controlled Interactions. U.S. Patent Application allowed.

17. Navigation and Viewing in a Multidimensional Space. Continuation application of U.S. patent 6,954,899 and others.

18. Navigation and Viewing in a Multidimensional Space. Second Continuation application of U.S. patent 6,954,899 and others.

19. European Patent Office Application Serial No. 03016030.3, filed July 15, 2003 entitled "Parallel Kinematics Mechanism." Counterparts in U.S., Japan, and Canada pending.

Additional Hardware Patents.

Country	Filing Date	Application Number	Registration Date	Patent No.
20. Canada	12-15-86	525321	04-14-1992	1,298,806
21. Japan	12-10-86	50331/1986	05-20-1993	1,761,286
22. Switzerland	12-16-1985	5348/85-6	10-31-1989	672089-4
23. USA	12-10-1986	07/403,987	12-11-1990	4,976,582
24. Europe	12-10-1986	86906759,5	07-17-1991	0250470

25+. Novint was also assigned a patent from Force Dimension that will be valuable in further cost-reducing our haptic, and other haptic hardware, designs. PCT application submitted, and several patents pending worldwide.

Product's Primary Function

The award-winning Novint Falcon is the first controller that makes high-fidelity interactive three-dimensional touch possible and practical for consumer computing applications. Although it is applicable to, and could fundamentally change and improve, dozens of billion-dollar markets, it is being introduced initially as a PC game controller. The Novint Falcon is, essentially, a small robot, yet its industrial design is something that consumers will enjoy having on their desktop. Although it gives extremely complex 3D-touch interactions, it is beautiful in its fundamental simplicity and elegance.

Beyond our initial entry to the \$35 billion global video game market, Novint's 3D-touch technology is relevant and applicable to many other consumer industries such as toys, electronic learning and educational products, cars, home media systems, and even as an interface for computer operating systems.

Imagine sliding open a drawer in a physical file cabinet to – virtually – place a document, or intuitively walking around a physical room to access applications. Adding 3D-touch to web applications, like online shopping, delivers on the full promise of the Internet as a “virtual world.” Children can play with a virtual Mr. Potato Head™, feeling the eyes and mouth fit into the potato body as in real life. A child might build a plastic-block castle, learn how molecules work by shrinking down to a microscopic size to interact with them, or play a game of chess moving physical pieces on a physical, but virtual, board. A son might meet his father in a virtual café, reach across the table for a hug, and then hand a picture across the table before leaving to take a trip to a virtual museum together. A consumer might pick up and feel the weight of a virtual watch, or take a test drive with a virtual car, feeling how it handles and the texture of the interior fabric.

Virtual interactions as we currently know them will be forever changed by the introduction of high-fidelity interactive touch.

Touch-enabled virtual stores let customers feel products and make more informed buying decisions. Advertisers gain a compelling new tool that lets their customers interact with

Product's Primary Function

With its effortless glide and touch interface design, and sophisticated engineering, the Novint Falcon, like its namesake, is a natural predator of the mouse, and is destined to change computing forever.

their products in the same way they would in a real-life retail location, without the expense. This is not limited to computer interactions. Using Novint's technology you could interact with digital photographs, movies, or video content. You could pet a virtual dog, feeling its fur, or touch a friend's face across the planet. Virtual interactions as we currently know them will be changed forever by the introduction of high-fidelity interactive touch. Can you imagine life without having the connectivity telephones and the Internet bring you? Our 3D-touch technology will take those interactions to a whole new level.

"Novint Technologies opened our eyes to what it's like to actually feel a game. The Falcon is a first-of-its-kind PC peripheral that makes use of force feedback to allow users to experience artificial 3D-touch 'Haptic' sensitivity of virtual objects. Three articulated arms attach to a center grip that can control games just like a mouse, and highly-developed algorithms apply appropriate forces of resistance to create realistic impressions of weight, recoil, and shock. We demoed the Falcon with Half-Life 2 and were blown away. Shotgun blasts produced hard, lurching recoil, while automatic machine gun fire was fast and light with an upward pull on the handle, simulating the barrel-rise effect of automatic fire. Lifting a box put weight on the handle, and taking damage from the side jerked the controller appropriately as our character stumbled away. We were blown away..." IGN, Best of E3: Gear, 2006 (<http://gear.ign.com/articles/709/709246p1.html>)

What's in a name?

The Novint Falcon takes its name from one of nature's most powerful birds of prey. Moving gracefully through the air in three dimensions, our Falcon outperforms existing force-feedback joysticks and traditional mice, delivering high-fidelity 3D touch and a realistic and immersive experience that surpasses existing point and click technology. With its effortless glide and touch interface design, and sophisticated engineering, the Novint Falcon, like its namesake, is a natural

Product's Primary Function

Instead of using mouse clicks and meters, players feel the weight of a basketball as they shoot it toward a hoop; the momentum and impact as they swing a virtual golf club and strike a ball; the recoil of a weapon; and the characteristics of virtual objects and environments.

predator of the mouse, and is destined to change computing forever.

We are pioneering a new category of touch products for the consumer market, beginning with the release of the Falcon in 2007. The company also intends to license its patented technology to game and hardware companies. In the past, the cost of 3D-touch (haptic) hardware (tens of thousands to hundreds of thousands of dollars) made the technology impractical for consumer applications, but the Novint Falcon, which performs comparably to commercial devices that cost thousands of dollars, will retail initially for under \$200, and is designed to retail for under \$100 in high-volume, mass-market quantities, making it affordable and accessible to consumers for the first time. In June 2007, the company will introduce a Limited Edition Novint Falcon Bundle with an MSRP of \$239 (available for \$189 in pre-orders). The bundle includes a Limited Edition controller and Newton's Monkey Business, a collection of 24 touch-enabled mini-games.

How the Novint Falcon Works

Our Falcon is, in essence, a small robot that lets users feel weight, shape, texture, dimension, dynamics, and force effects when playing enabled games. Using the Falcon, players experience a full range of realistic touch sensations that allow them to control a game more naturally and intuitively. Instead of using mouse clicks and meters, players feel the weight of a basketball as they shoot it toward a hoop; the momentum and impact as they swing a virtual golf club and strike a ball; the recoil of a weapon; and the characteristics of virtual objects and environments. The Novint Falcon is also the only consumer game controller that provides players with both 3D input and high-fidelity force feedback.

Users hold onto the Falcon's interchangeable Grip (or handle), which moves left and right and forwards and backwards, like a computer mouse, but also moves up and down. (Please view

Product's Primary Function

"We demoed the Falcon with Half-Life 2 and were blown away. Shotgun blasts produced hard, lurching recoil, while automatic machine gun fire was fast and light with an upward pull on the handle, simulating the barrel-rise effect of automatic fire. Lifting a box put weight on the handle, and taking damage from the side jerked the controller appropriately as our character stumbled away. We were blown away..."
-IGN, Best of E3: Gear

the included video to see the Falcon in action.) The Grip can come in many shapes and forms and includes a quick disconnect feature which lets users change handles for specific uses or types of game play. As the Grip is moved, the computer keeps track of a 3D cursor. When the 3D cursor touches a virtual object, the computer registers contact with that object and updates currents to motors in the device to create an appropriate force to the device's handle, which the user feels. The computer updates the position of the device, and updates the currents to the motors a thousand times a second (i.e., at a 1 kilohertz rate), providing a very realistic sense of touch. The three electrical motors are connected to the three arms extending out of the device, with one motor connected to each arm. The three arms are connected to the device's handle. At any given cycle, or 1/1000th of a second, the device can create a force on the handle in any direction of any magnitude, up to the maximum force.

As an example, when a 3D cursor touches a virtual sphere, there is a force normal (perpendicular) to the surface. The device reacts and pushes in the radial direction away from the center of the sphere, proportional to how hard the user pushes against the sphere. The computer keeps track of the direction of the force (based on the position of the cursor) and the amount of the force, 1000 times a second, which lets the user slide the 3D cursor across the surface of the sphere, giving it a consistent smooth feel. The effect is that the cursor, and therefore device, physically cannot move through the sphere, and it is actually a virtual solid object. When one looks at the Novint Falcon itself (rather than the cursor and sphere graphics on the computer screen), one can see the "invisible" sphere in the haptic workspace where the haptic device cannot move – it is really there, and you can really touch it! Additionally, other forces and algorithms can be used to give the sphere texture, dynamic properties (i.e., it can bounce like a ball), deformability, or a variety of other effects.

Product's Primary Function

Development Partners

Novint's software technology is largely based on technology originally developed at Sandia National Laboratories, which was exclusively licensed by Novint for commercialization. Novint also partnered with Lunar Design (www.lunar.com), an award-winning industrial design firm, and Force Dimension (www.forcedimension.com), a leading Swiss developer of high-end haptic devices, in the development of the Falcon.

Technical Specifications for Novint Falcon

3D Touch Workspace	4" x 4" x 4"
Force Capabilities	> 2 lb
Position Resolution	> 400 dpi
Quick Disconnect Handle	< 1 second change time
Communication Interface	USB 2.0
Size	9" x 9" x 9"
Weight	4 lb
Power	30 watts, 100V–240V, 50Hz–60Hz

All specifications are approximate and subject to change.

What Is Haptics?

Haptics is the scientific field that studies the sense of touch. In computing, haptics is the science and art of applying touch sensation to human interaction with computers. A haptic device gives people a sense of touch with computer-generated environments so that when virtual objects are touched, they seem real and tangible. An example is a medical-training simulator in which a doctor can feel a scalpel cut through virtual skin, feel a needle push through virtual tissue, or feel a drill passing through virtual bone. All of these types of interactions can feel almost indistinguishable from the real-life interactions the simulator emulates.

Product's Primary Function

Haptics is applicable across nearly all areas of computing including video games, medical training, scientific visualization, CAD/CAM, computer animation, engineering design and analysis, architectural layout, virtual toys, remote vehicle and robot control, automotive design, art, medical rehabilitation, and interfaces for the blind, to name a few. The word 'haptics' derives from the Greek *haptikos*, meaning "to grasp, touch, or perceive."

In computing, haptics is implemented through different types of interactions with a haptic device communicating with a computer. These interactions can be categorized into the different types of touch sensations a user can receive: **force feedback**, **tactile feedback**, and **proprioception** (or **kinesthesia**).

With **force feedback**, a user can feel forces applied to a user's body by the movements of a haptic device, sensed by the user primarily through musculoskeletal forces, but also through the skin that touches the physical interface to a haptic device. This is often accomplished through a user's hand grasping a handle connected within the device to motors (e.g., 3D haptic devices, like the Novint Falcon, and 2D haptic devices, like force-feedback steering wheels and force-feedback joysticks). It can also be implemented with haptic devices that a user puts a hand, arm, or leg into (e.g., a haptic glove or sleeve); vibrating motors within something that is held (e.g., a game controller or a force-feedback mouse); a vibrating or moving object that a user sits on; or any other mechanical system that can give forces or touch sensations to a user. Haptics is often accomplished through electrical motors, although there are other methods to create force sensations, such as with devices that are pneumatic (air controlled), hydraulic (fluid controlled), piezoelectric (materials that expand or contract with electric current), electric (sending currents directly to a user's skin or nervous system), or which use passive braking systems.

Product's Primary Function

With **tactile feedback**, a user can feel forces applied directly to the skin, which are detected by a user through sensors within the skin called mechanoreceptors. Tactile feedback can also be applied to a user through electrical currents applied directly to the skin or objects that can vary in temperature touching the skin. For example, tactile feedback can be accomplished with pin arrays on a haptic device that a user places a hand or finger on. The pins within the pin array can slightly raise or lower as the haptic device moves, giving a sensation that the user's finger or hand is moving across a virtual object with texture.

Proprioception is the sense of where your body is in space. For example, if you move your arm out to the side, even if your eyes are closed, you know where it is. Our sense of proprioception is derived from the forces our muscles exert within our body. Force feedback generally has a proprioceptive component, as a user's movements of a haptic device in correlation with an application create the forces one feels. Even computer input devices that are generally not considered haptic devices use our sense of proprioception, such as mice and keyboards.

Kinesthesia is similar to proprioception, in that it is a sensation of strain in muscles, and through it we know our body position, but kinesthesia also includes other internal feelings such as the feeling of a full stomach.

Haptic devices have varying complexities, and can move in different ways. Force-feedback devices are often described by their Degrees of Freedom (DOF). A DOF refers to a direction of movement. Common DOF include right-left movement (X), up-down movement (Y), forwards-backwards movement (Z), roll (rotation about the Z axis), pitch (rotation about the X axis), and yaw (rotation about the Y axis). DOF can refer both to how a device keeps track of position, and how a device outputs forces. A computer mouse, for example, is a 2 DOF input device – it keeps track of position in the right-left DOF, and the forward-backward DOF. A joystick is also a 2 DOF device, but its Degrees

Product's Primary Function

of Freedom are different (it rotates forwards-backward, and right-left). A force-feedback joystick is a 2 DOF device with force feedback. It both tracks 2 DOF and gives simple forces in 2 DOF. The Novint Falcon, is a 3 DOF force-feedback device. It tracks in 3 DOF (right-left, forwards-backwards, and up-down), and gives forces in those same DOF. 3 DOF devices (and higher DOF devices) are significantly more complex than 2 DOF devices.

Product's Competitors

The Novint Falcon is the first 3D-touch device for consumer applications. Therefore, there are no other products directly in its category. The Falcon is compared to existing technologies, however, in the following product matrices.

Comparison Matrix

Existing Game Controllers:

	Novint Falcon	Force-Feedback Mouse	Force-Feedback Joystick	Force-Feedback Steering Wheel	Gamepad	Console 3D game inputs
	3	2	2	1	2	3
Movement Directions (RL = Right left) (FB = Forwards Backwards) (UD = Up Down)	RL FB UD	RL FB	RL FB	RL	RL FB	RL FB UD
Rumble/Vibration Force Feedback	Yes	Yes	Yes	Yes	Yes	No
3D shape exploration	Yes	No	No	No	No	No
High-fidelity Force Feedback, Textures, and Interactions	Yes	No	No	No	No	No
Real Dynamics Modeling (user-perceived weight, momentum, inertia, etc)	Yes	No	No	No	No	No
Consumer Price Point	Yes	Yes	Yes	Yes	Yes	Yes
Handle	Many Variations	Mouse	Joystick	Wheel	Gamepad	Varies
Average Table Footprint	9"X9"	9"X9" mousepad	9"X9" and up	9"X9" and up	6"x4"	Varies
Connection (most common)	USB	USB, PS2	USB	Console Specific and USB	Console Specific	USB
Fundamentally improved way of playing/interacting	Yes	No	No	Yes	No	Yes
Applicable across all genres of gaming	Yes	Yes	Yes	No	Yes	No
Game play possible with non Force-Feedback version (i.e., is Force-Feedback simply an incremental improvement to standard game play)	No	Yes	Yes	Yes	Yes	N/A

Comparison Matrix

New, Advanced Game Controllers and High-End Haptic Devices

	Novint Falcon	Nintendo Wii remote	PS3 Controller	SensAble Phantom	Other High-End Haptic Devices
Degrees of Freedom	3 + 3 with enhanced handle	6	3	6	2 to 6
Movement Directions (RL = Right left) (FB = Forwards Backwards) (UD = Up Down)	RL FB UD With enhanced handle: Roll Pitch Yaw	RL FB UD Roll Pitch Yaw	Roll Pitch Yaw	RL FB UD Roll Pitch Yaw	RL FB Sometimes: UD Roll Pitch Yaw
Rumble/Vibration Force Feedback	Yes	Yes	No	Yes	Yes
3D shape exploration	Yes	No	No	Yes	Yes
Real Dynamics Modeling (user-perceived weight, momentum, inertia, etc)	Yes	No	No	Yes	Yes
Consumer Price Point	Under \$200	Console \$249	Console \$599	\$2000 to \$10,000's	Usually greater than \$10,000
Handle	Many variations	Wii Remote	6 Axis controller	Pen/Stylus	Varies
Average Table Footprint	9"x9"	handheld	handheld	5"x5"	Varies
Connection (most common)	USB	Console Specific	Console Specific	Firewire	Varies
Fundamentally improved way of playing/interacting	Yes	Yes	No	Yes	Yes
Applicable across all genres of gaming	Yes	Yes	Yes	Yes	Sometimes
3D control comparable to real-life interactions	Yes	Yes	No	Yes	Sometimes
High-fidelity Force Feedback, Textures, and Interactions at a consumer price point	Yes	No	No	No	No
High-precision 3D control at a consumer price point	Yes	No	No	No	No
Real-life style of gameplay, with accurate muscle memory development at a consumer price point	Yes	No	No	No	No

How the Novint Falcon Improves upon Competitor's Products

The Falcon lets players feel a character's actions instead of controlling them through mouse clicks or meters.

Some innovations represent incremental improvements and some change the world forever. Consider how the introduction of sound changed motion pictures, or how graphics made the Internet what it is today. The Novint Falcon makes interactive 3D touch possible and practical for consumer computing applications for the first time, fundamentally changing how people play and interact.

Using the Novint Falcon, computer game players experience a full range of realistic touch sensations and haptic effects, enabling them to control a game more naturally and intuitively. The Falcon lets players feel a character's actions instead of controlling them through mouse clicks or meters.

It is the first consumer controller in decades (since the mouse, the first gamepad, and the joystick) that has two characteristics – it fundamentally changes the ways that games are played and it is applicable across all genres. The Novint Falcon can accurately simulate both the movements and feedback of throwing a basketball, swinging a golf club, twisting back and forth down a ski slope, or stacking blocks in a building game. The Falcon's highly accurate tracking and extremely realistic force feedback allow a user to play games and learn muscle memory much the same way real-life games and sports are played.

For the first time, players can 'become the character' and feel what the character feels, instead of just pushing buttons to control a game. Novint makes the old way of playing games obsolete, adding a powerful new dimension to the user's experience and providing our licensees with new revenue opportunities and a significant market differentiator.

Principle Application

The Novint Falcon is being applied initially primarily in the video game industry, but it is applicable across many fields. The included video of gameplay shows how the Novint Falcon is used in gaming. Shown in Appendix B are examples of how the technology is used in video games.

Worldwide sales of video game hardware and software are expected to reach \$35 billion this year and are projected to grow to \$56 billion by 2008. Jupiter Media Matrix reports that there will be 235 million gamers by 2007 and U.S. software sales continue to outpace domestic box office revenues. Although games have incorporated increasingly sophisticated graphics and sound design, none have integrated realistic touch feedback. Novint is pioneering a new category of consumer products for the video game market that lets you experience a realistic sense of touch on your computer.

In 2007 we will introduce our flagship product, the Novint Falcon, which lets gamers accurately and realistically feel shape, texture, weight, dynamics, 3D motion, and force effects when playing our touch-enabled games, which will be developed primarily by third-party developers. Although we are initially focusing on the game market, our technology has broad applications in many markets, which we will aggressively pursue as our business expands.

Novint has the rare opportunity to introduce a new category of products to the market. Our 3D-touch technology will revolutionize computing, become ubiquitous and, ultimately, replace the computer mouse. Imagine the possibilities...

Other Applications

A doctor can learn a procedure by practicing as many times as he or she wants without any additional cost, and with a push of a button can operate on a 70-year-old man versus a 6-year-old girl, add in complications or varying anatomies, and prove his or her proficiency before ever touching a live patient.

Novint's patented technology is a seminal innovation with broad and transformative applications in major consumer, commercial, and industrial markets. Our sense of touch connects us both physically and emotionally to the world around us. Novint's technology lets users not only see and hear, but also feel their interactions. Our sense of touch is the only sense that is bi-directional— we both view the world and change it. Once people experience Novint's 3D-touch technology and start feeling, the world will never be the same.

Today, the concept of true interactive touch is generally unfamiliar to people, in the same way the idea of television was unimaginable in the age of radio. But, like TV, which brought moving pictures into our living rooms, we envision a near future when our haptic technology is as commonplace as the computer mouse. When you think about how integral touch is to our everyday lives and then consider how almost every computer-mediated experience omits this important sense, you can begin to imagine the enormous potential that our 3D-touch technology represents.

The commercial arena offers vast opportunities for our unique technology. Novint has already developed applications in a number of significant commercial areas, yet the potential is still significantly untapped. As an example, we developed medical training applications that enable physicians to learn and practice procedures without jeopardizing human patients. We see a day when most doctors will learn most of their medical procedures using our technology. A doctor can learn a procedure by practicing as many times as he or she wants without any additional cost, and with a push of a button can operate on a 70-year-old man versus a 6-year-old girl, add in complications or varying anatomies, and prove his or her proficiency before ever touching a live patient. Beyond training, a surgeon might use our technology to visualize and view a CT scan or MRI to better understand it before a complicated brain surgery, or view the real-time implantation of a radioactive seed into a

Other Applications

A sculptor can push and pull on virtual clay as in real life, allowing an artistry that computers currently do not give.

prostate as a treatment for prostate cancer, making sure it is placed correctly. A doctor might evaluate and palpate a virtual polyp from an MRI and detect colon cancer without an invasive and unpleasant colonoscopy. One appealing application we see for our technology is in aiding the disabled. Our technology can be used for stroke rehabilitation or even to provide a user interface for blind users.

Novint's technology can also be used in a number of visualization tools that enable scientists, doctors, researchers, and others to virtually interact with complex data. Scientists can gain new understanding into complex computer simulations, such as understanding a complex geoscientific data set. Our technology can be used for telerobotic controls, which facilitate remote exploration and operations in medical, undersea, hazardous materials, and other fields and locations by allowing intuitive and efficient control of robots. For example, a policeman might utilize our device to remotely control a bomb-diffusing robot.

Many of these custom applications also translate to consumer products. Our Novint sono, which is used to interact with 3D ultrasound images, allows expectant parents to virtually touch their child in utero and bond in this special way with their baby before birth. Our technology may also be used for virtual modeling, CAD/CAM, computer animation, and many other disciplines. A sculptor can push and pull on virtual clay as in real life, allowing an artistry that computers currently do not give. A painter can feel a paintbrush slide across a canvas, and with a push of a button change it to chalk, along with the appropriate change in feel.

The military has invested heavily in virtual training and simulation technology. Our hardware and software solutions represent compelling advancements to their existing methodology and provide realistic real-time simulation, as well as real-world

Other Applications

applications. With low-cost hardware, recruits may be trained using 3D-touch devices that accurately simulate weapons and build other critical skills. Telerobotic haptic devices will let military doctors assess and treat patients remotely on a battlefield. A 3D interactive visualization tool can even efficiently allow the military to navigate and interact with a complex battlefield on a computer in real-time combat. Our technology can be used to realistically simulate driving a tank, or other vehicles or heavy machinery in both military and commercial training, sales, and marketing applications. These solutions provide next-generation tools for a variety of applications and are not only more effective, but may also save lives.

Novint does custom development and consulting for industry in any application involving user interaction with 3D computer data, models, or environments.

Medical Applications

The sense of touch is crucial for medical training. Many diagnostic, surgical, and interventional procedures require that physicians train and utilize their sense of touch, which made effective medical training utilizing computers infeasible – until now. Novint's technology and medical products add this missing component to computer-based training and simulation. Our VoxelNotepad (VNP), which was originally developed for uses in the petroleum industry, enables users to interact with medical imagery including MRIs, CT scans, and 3D ultrasounds.

In conjunction with Harvard School of Dental Medicine, Novint has also developed an advanced prototype of a Virtual Reality Dental Training System (VRDTS) that enables students to practice a variety of procedures using a computer. During training, a dental student must learn to control surgical instruments very precisely, and develop a sophisticated feel for the interaction of these instruments with patient anatomy. Yet today, most dental students learn basic procedures with plastic

Other Applications

teeth, hardly the best way to learn how to operate on live patients. Furthermore, with these traditional training methods, it is nearly impossible to quantify a student's proficiency. To address these shortcomings, Novint is developing a family of Dental Simulators which incorporate a very life-like sense of touch, as well as 3D graphics and sound, to provide dental schools with realistic and quantifiable training systems.

Using VRDTS, dental students work with a virtual decayed tooth and learn to probe it for diagnosis, use a drill to prepare a tooth for cavity repair, fill the prepared cavity with amalgam, and carve the amalgam to match the original tooth contour. Novint's hardware provides high-fidelity simulation of the Explorer, Drill, Carrier, Tamper, and Carver tools. Unlike plastic teeth, VRDTS enables the student to feel the difference between enamel, dentin, caries, amalgam, and pulp throughout the procedure. The student's operation can be tracked precisely in real time, providing quantifiable feedback to both student and teacher. Since the entire process is virtual, the student has the ability to zoom, rotate, and even cut the tooth in cross-section to better understand the process. VRDTS offers a number of enhancements over current approaches to dental training, enabling a student to practice procedures with confidence, as often as needed, with no additional cost for materials.

Design and Architectural Tools

A significant market for our technology is in an area we have coined **Instant Prototyping™**. With Instant Prototyping, a manufacturing company can instantly create a virtual prototype from its digital models for design and analysis purposes. This speeds up the production cycle and mitigates the need for the manufacture of costly physical prototypes. In many cases, our Instant Prototypes can completely replace physical prototypes.

Other Applications

With our architectural walk-through application, a user can walk around a virtual building in full 3D. The user can see and feel buildings – even read posters on the wall.



This technology has wide applicability in the overall design and manufacturing arena. Any effort where physical prototyping adds to the cost or time of the design cycle is a candidate for Instant Prototyping. It can also be used in processes where the scale of the manufactured product makes physical prototyping less than optimal. Instant Prototyping is advantageous for both very small scale (e.g., microelectromechanical systems) and large scale (e.g., buildings or vehicles) product design.

Architectural objects, such as chairs, can be picked up and placed in a touch-enabled manner. The user can feel the shape and weight of these objects and the impact when they collide with other objects in the environment.

Novint developed an architectural walkthrough application for Sandia National Laboratories. This application allows users to load large-scale, detailed architectural models and to explore their design using Novint's technology. Haptic technology is used in both the user interface to this application and to allow the user to feel the digital models to get a more precise understanding of their nature and extent. In addition, various touch-enabled programs can be launched as the user navigates in the digital realm. For example, if the user enters a "medical building" in the simulation, a medical visualization program can be instantiated.

This effort allowed us to develop an overall framework that can launch applications based on location in an overall digital model or virtual environment. This technology is applicable to areas such as Geographic Information Systems and has implications for consumer efforts. The ability to read virtual reality modeling language format models was also added to Novint's technology during this effort.

Other Applications

With **Novint Layout**, digital objects may be quickly and unambiguously arranged and placed. Novint Layout was developed for Sandia National Laboratories to aid in the interior layout of buildings. Architectural objects, such as chairs, can be picked up and placed in a touch-enabled manner. The user can feel the shape and weight of these objects and the impact when they collide with other objects in the environment. In addition, the movement of the digital objects can be constrained. For example, the motion of a door can be constrained to only pivot around its hinges.

Although developed within an architectural context, the capabilities found in Novint Layout are important in many applications. Using Novint's technology for the placement of 3D digital objects means that objects can be organized much faster than when using a mouse, and it also means that their placement in the environment can be much more precise. The user merely has to reach out, "grab" an object, and place it to get the job done – just as in the physical world. For example, a user can pick up a virtual vase and place it on a virtual table and know that it is properly placed since he or she will feel the vase placement on the table. The Novint Layout effort has allowed us to extend Novint's technology to be able to impose motion constraints on digital objects and to handle real-time collision detection between digital models. Constraining and quickly fitting and placing objects are fundamental to many applications including those in design/manufacturing and in the computer graphics and animation industries.

Automotive Modeling

Our initial focus in design and manufacturing has been in the automotive arena. For example, our Tactile Device Interface (TDI) application, developed for a major automotive company, is used to simulate and evaluate car interior design and ergonomics. We simulate a full arm-length area of interaction in a one-to-one scale using a large workspace haptic device. Utilizing this device, TDI adds touch feedback to virtual car

Other Applications

prototyping capabilities. TDI enables more cost effective and realistic design and evaluation of car ergonomics prior to the manufacture of physical models.

As part of the TDI project, Novint developed a new and unique haptic rendering algorithm that allows touch interaction with less-than-perfect digital models. This capability is significant in that it allows haptically enabled evaluation much earlier in the product design cycle. This algorithm allows touch feedback to generate fingertip interactions with virtual models more realistically. We also added the ability to read Alias Wavefront (i.e., *.obj) format files and stereolithography format files to our collection of CAD surface model readers.

Tire Modeling

We have researched and built a proof-of-concept application for an Instant Prototyping product used in the tire manufacturing process. The goal of the effort is to mitigate the need for physical prototypes to be developed in the tire manufacturing process. This will lead to significant time and cost savings and will further validate our Instant Prototyping technology and approach.

Currently, as part of some tire manufacturing processes, an artist takes two-dimensional CAD drawings and literally sculpts

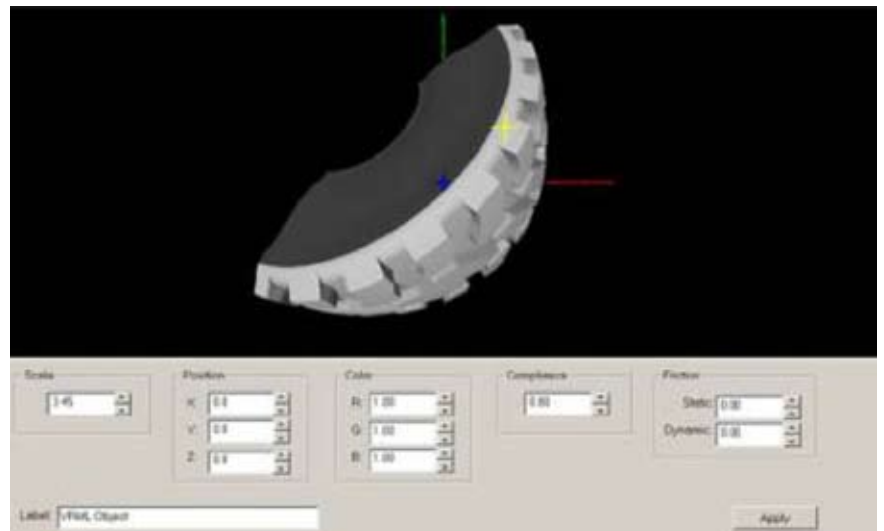

Proof of concept of the tire evaluation application

Other Applications

Our Instant Prototyping technology will allow tire manufacturers to significantly decrease the cost and time required to develop new tires. Users will be able to see and feel their designs in the digital realm so that fewer plaster models will need to be built. Moreover, our technology will allow tire design personnel to evaluate and modify their designs in ways that are not currently possible. Our software will automatically load in the 2D tread designs and instantaneously create a virtual prototype. Designers will have the same evaluation capabilities as with a plaster model and digitally enabled enhancements as well. A designer will be able to feel across a tread, feel the transition to the sidewall, and take measurements with specially designed virtual tools. If errors are found, digital design tools can be used to modify the 3D virtual prototype. After a digital tire model is evaluated and modified, our software can be used to output to an automated manufacturing system, eliminating much of the human error that is currently part of the tire design and manufacturing process.

Our software will save hundreds of thousands of dollars for each tire that is designed and manufactured, while helping remove errors and flaws.

3 views from the v-Dig application are shown. While planning an underwater mission, a user can see the underwater vehicle from several angles, including the view that will be seen during an actual mission. The right panel shows a brush digging through the silt which the user can feel.

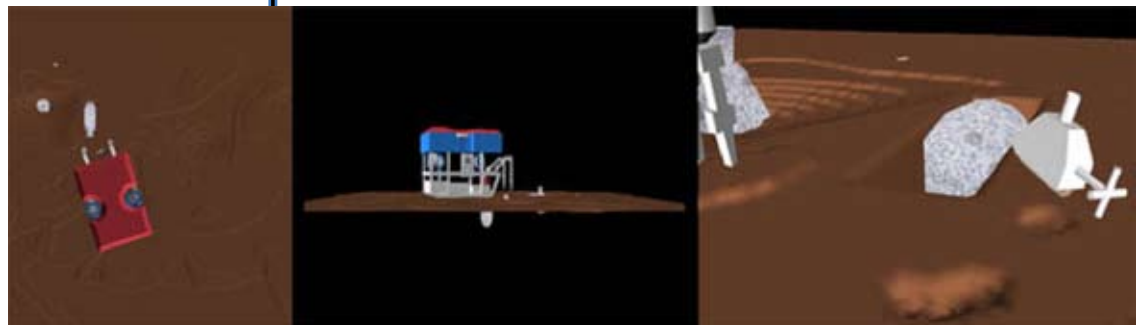

Undersea Exploration

Novint is working with an oceanographic institute to integrate haptic interaction into undersea exploration systems (i.e., underwater vehicles). In this three-year effort, we are developing a 3D-touch-enabled mission rehearsal system (i.e., simulation) and real-time control system for underwater vehicle operations.

Other Applications

During the first year of this effort, we developed a touch-enabled, PC-based, virtual environment (VE) for mission rehearsal. This VE has been set up to help plan and practice undersea archeological expeditions. The user is able to control the motion of a model of a remotely operated underwater vehicle. The user can control the manipulators (i.e., robot arms) on the model and interact with the simulation of the bottom terrain and simulated archeological objects. The user can “dig” into the bottom using various excavation tools attached to the manipulator (e.g., brush and vacuum tools) and feel any collisions with the archeological artifacts. The bottom simulation is such that it acts like a mud bottom. Motion constraints can be added to the manipulator to limit its range of motion (e.g., avoid regions known to have fragile artifacts). During the second year of the effort, we will be extending the simulation to allow updating of the VE from the underwater vehicle’s sensors and to directly control its operation. We will be able to update the model of the bottom in real-time using sonar and video sensor information and we will be able to control the manipulators on the real vehicle.



CETUS™ Unmanned Underwater Vehicle

Telerobotic Underwater Vehicle Control

We are currently developing a mission planning system for an autonomous underwater vehicle. This system will allow users to plan the overall mission for a CETUS™ (Composite Endoskeleton Testbed Untethered Underwater Vehicle Systems) system. This underwater vehicle is a new low-cost, unmanned underwater vehicle used for undersea search and inspection. Our mission planning system allows the user to control the vehicle and understand its status in a straightforward, easy-to-use manner.

Other Applications

Petroleum Applications

Major oil companies, such as Aramco, Mobil, and Chevron, have funded much of our ongoing 3D-data-interaction efforts. This revenue has helped Novint to become self-supporting, to develop a series of products that have direct applicability to petroleum exploration and production, and to continue to develop our core volumetric and surface visualization, evaluation, and modification technologies. Due to the universal nature of the 3D data that is handled by these applications (i.e., volumetric and surface), the underlying technology and the applications themselves can and have been used in other areas where this kind of data is generated. For instance, volumetric data is used extensively in medicine, and work performed for the petroleum industry can be leveraged for our medical efforts. Surface data is used in the design and manufacturing domain as well. As a result, our petroleum-related development work is broadly applicable, and has created a foundation for many of Novint's subsequent successes.

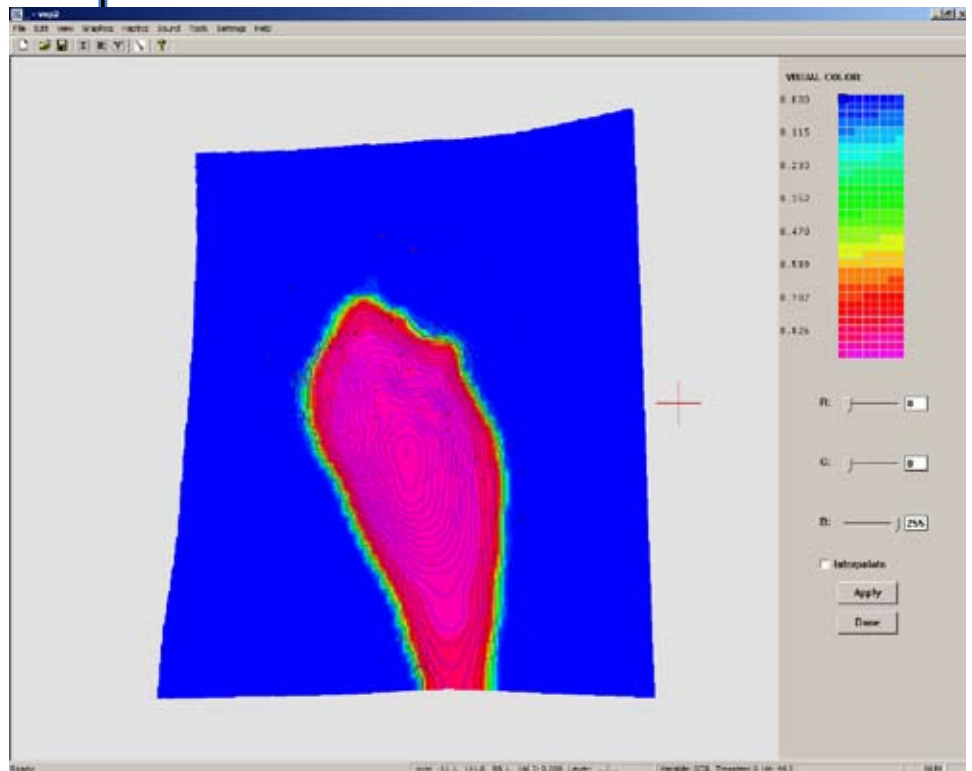

VNP2 Microsoft Windows User Interface

Other Applications

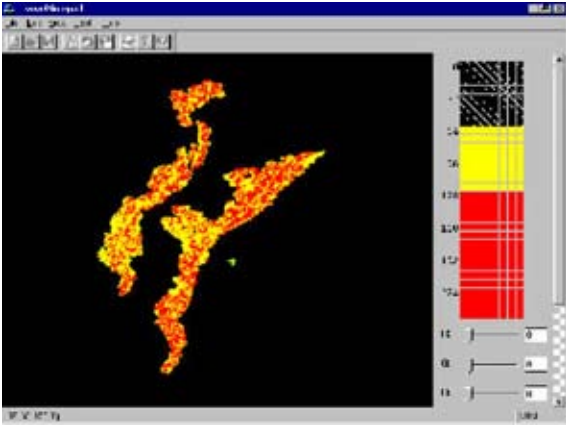

Geophysical Data in VoxelNotepad

... data representing different geological structures can be quickly recognized and characterized by differences in feel as well as appearance.

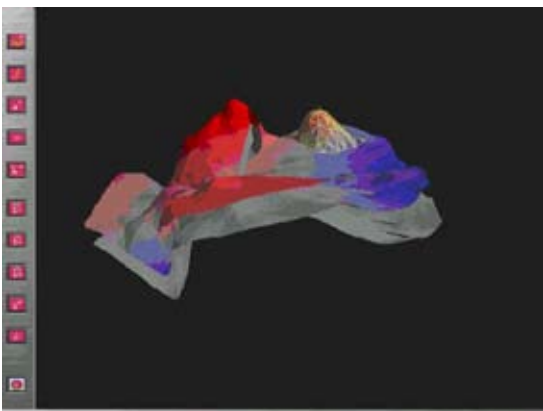

Geophysical Structures in Touchstone

This application allows Mobil scientists and interpreters to better understand their 3D (i.e., volumetric) data by mapping data attributes to touch properties such as hardness, viscosity, and vibration. This means that data representing different geological structures can be quickly recognized and characterized by differences in feel as well as appearance. In addition, VNP allows 3D data models of oil fields and other geological structures to be interactively modified. Prior to VNP, updating these 3D models was extremely tedious and time-consuming. Interpreters were forced to modify large 3D data sets by editing 2D slices of the data one at a time on a per "pixel" basis. With VNP, interpreters can modify the 3D data directly and interactively. Force feedback provides invaluable information concerning the nature of the data being edited and helps guide the editing process organically.

Much of the technology developed for VNP is fundamental and can be applied to any data that is in volumetric format. This includes data from remote sensing applications (e.g., undersea and space exploration) and data from medical imaging devices such as CT, MRI, and 3D ultrasound machines.

As part of a geological modeling effort for Chevron, the TouchStone™ application touch-enables the creation and modification of boundary models of the sub-surface environment. As part of the oil exploration and production process, boundary models of important geophysical structures are created and refined based on seismic and other empirical oil field data. Like any CAD surface model, these boundary models need to be created, understood, and refined. Prior to the development of TouchStone, the creation, evaluation, and modification of these 3D models had been hampered by the lack of touch feedback. Haptic interactions allow modelers to quickly and precisely designate the location of surfaces; feel as well as see their extent and shape; and directly modify them using their sense of touch. Like the creation and modification of physical models in everyday life, the creation and modification of

Other Applications

digital models is difficult and impoverished without the sense of touch. The TouchStone application has added this crucial sense of touch to digital modeling.

Within the context of the TouchStone effort, we have developed technology that allows the haptically enhanced creation, evaluation, and modification of large polygonal models. The polygonal algorithms are able to handle 1 million-polygon models in real time on PC-class computers. These capabilities are fundamental to any application that creates, uses, or changes CAD models.

In conjunction with geoscientists at Saudi Aramco, Novint is extending its oil exploration and volumetric visualization/ modification application VoxelNotepad. In this five-year effort, capabilities are being added to VoxelNotepad, now known as VoxelNotepad2 (VNP2), to support and enhance the oil reservoir and well-path modeling process. The project is aimed

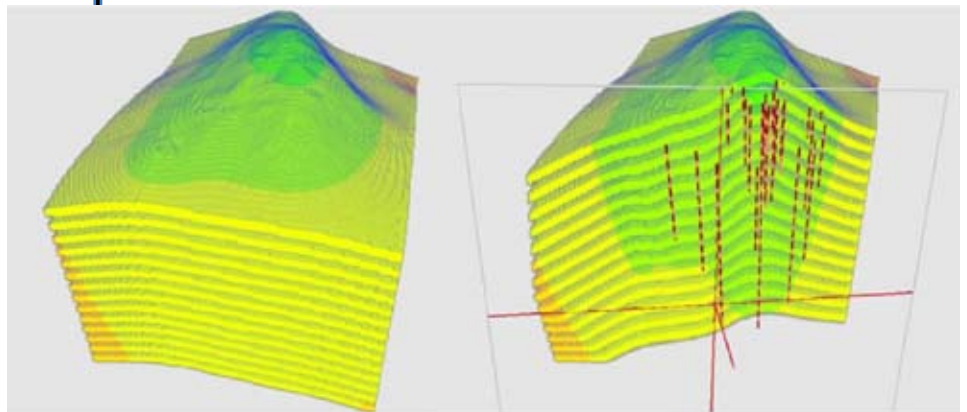

Reservoir models in VoxelNotepad2

at demonstrating and validating the use of haptic interaction techniques in the interpretation and understanding of volumetric reservoir-modeling data by Saudi Aramco on a desktop virtual reality environment. Once this initial phase is completed, a full production version of VNP2 will be used throughout Aramco.

3D tools, such as the clip plane shown above, intuitively controlled by a 3D input device, allow a user to quickly visualize and understand complex 3D data.

Other Applications

During the first year of this effort, the voxelNotepad2 program was extended and enhanced in order to enable the interpretation of data from commercial and developmental oil reservoir modeling programs, using the Schlumberger ECLIPSE data format. Layer, time-step, and well-path data are now supported in VNP2 and can be seen and felt in real time in the desktop environment. Data sets on the order of 500,000 data "cells" were supported in Year 1. Our success and results during the first year led to the award of a contract for Year 2. During the second year, we further refined VNP2 to be able to handle full production-level oil reservoir model data sets (approximately 1-3 million data cells in size), and added additional visualization support to allow oil company personnel to focus on key areas of their models. Our Aramco customers felt that these new capabilities were sufficient to justify using VNP2 in their oil production process, and to justify the renewal of our contract for another year. The main goals of Year 3 were to further refine and extend the VNP2 software to support simultaneous interactive visual, haptic, and auditory (i.e., multimodal) rendering of multiple reservoir properties. In addition, VNP2's loading and rendering performance was improved, and stereographic visual rendering was added. The following year, Aramco requested that Novint incorporate features that would optimize VNP2's performance. Our work in Year 4 resulted in a significant increase in both the speed and capacity of the application, allowing for faster loading and the expansion of the number and size of volumes that could be loaded. Furthermore, we developed automated tools that help researchers discover and explore situations of interest more efficiently. Novint is currently entering the fifth year of our contract relationship with Aramco.

As with VNP, with the exception of the specific oil reservoir modeling file reader, the technology and capabilities developed in VNP2 are fully applicable to other applications utilizing volumetric data. The VNP2 efforts are particularly synergistic with our medical efforts. In particular,

Other Applications

this technology is critical to our Virtual Reality Dental Training System and 3D ultrasound efforts described in other sections of this document.

Summary

Three-dimensional touch technology — adding one of the most basic human senses to computing — may be one of the few technologies we will see in our lifetime that fundamentally changes computing, on par with the mouse, keyboard, monitor, and the Internet. It will become ubiquitous across computing. Our technology therefore embodies what the R&D 100 awards strive to recognize.

Technological Significance

One can read the reviews of our product (See Appendix C) as an indication of its significance across only one field, computer gaming. Our vision for the technology is much, much broader. It will undeniably improve the world, changing how doctors and children learn, how designers create, how people interact not only with computers but with each other virtually, and how people with disabilities use a computer. It will be used in the most basic interactions with computer operating systems to the most complex works of artistry, finally giving people a hand to reach into the computer.

The technology represents an entirely new field of computing that will be used by hundreds of millions of people over time. We believe in the significance of this entirely new field whether we ultimately are the leaders of it or not — fundamentally, it is our sense of touch finally being simulated realistically in computers. We feel the Novint Falcon and its software represents the first step towards this future.

Wow Factor and Uniqueness

There are few technologies that innately have the literal wow factor our technology has. Please view the included video of people's reactions to the technology as one indication (our most common reaction is a user literally saying "wow"). Also, please consider the press reviews. Both references are also a good indication of uniqueness. It is unlike anything most people have ever tried before.

NOVINT

Summary

Ultimately, a hands-on demonstration of the technology is needed to truly understand what it does. One touch is worth a thousand pictures ... or, if you do the math from the old saying, one million words.

Contact Person for Arrangements

Robert W. Carling, Director
Sandia National Laboratories
PO Box 969
Mail Stop 9405
Livermore, CA 94551-0969, USA
925-294-2206 (phone)
925-294-3403 (fax)
rwcarli@sandia.gov

Appendix A



US006208349B1

(12) **United States Patent**
Davidson et al.

(10) **Patent No.:** US 6,208,349 B1
(45) **Date of Patent:** Mar. 27, 2001

(54) **MULTIDIMENSIONAL DISPLAY CONTROLLER FOR DISPLAYING TO A USER AN ASPECT OF A MULTIDIMENSIONAL SPACE VISIBLE FROM A BASE VIEWING LOCATION ALONG A DESIRED VIEWING ORIENTATION**

4,811,608 *	3/1989	Hilton	73/862,043
5,296,871	3/1994	Paley	345/163
5,506,605	4/1996	Paley	345/163
5,742,264 *	4/1998	Inaaki et al.	345/8

OTHER PUBLICATIONS

Creve Maples, "Muse, A Functionality-Based Human-Computer Interface," *Journal of Virtual Reality*, vol. 1, Winter 1995.

* cited by examiner

Primary Examiner—Almis R. Jankus
(74) *Attorney, Agent, or Firm*—V. Gerald Grafe

(57) **ABSTRACT**

A display controller allows a user to control a base viewing location, a base viewing orientation, and a relative viewing orientation. The base viewing orientation and relative viewing orientation are combined to determine a desired viewing orientation. An aspect of a multidimensional space visible from the base viewing location along the desired viewing orientation is displayed to the user. The user can change the base viewing location, base viewing orientation, and relative viewing orientation by changing the location or other properties of input objects.

(75) **Inventors:** George S. Davidson; Thomas G. Anderson, both of Albuquerque, NM (US)

(73) **Assignee:** Sandia Corporation, Albuquerque, NM (US)

(*) **Notice:** Subject to any disclaimer, the term of this patent is extended or adjusted under 35 U.S.C. 154(b) by 0 days.

(21) **Appl. No.:** 08/834,616

(22) **Filed:** Apr. 14, 1997

(51) **Int. Cl.⁷** G06T 15/00

(52) **U.S. Cl.** 345/427

(58) **Field of Search** 345/419, 420, 345/425-433, 441, 355-358

(56) **References Cited**

U.S. PATENT DOCUMENTS

4,028,725 * 6/1977 Lewis 348/115

10 Claims, 4 Drawing Sheets

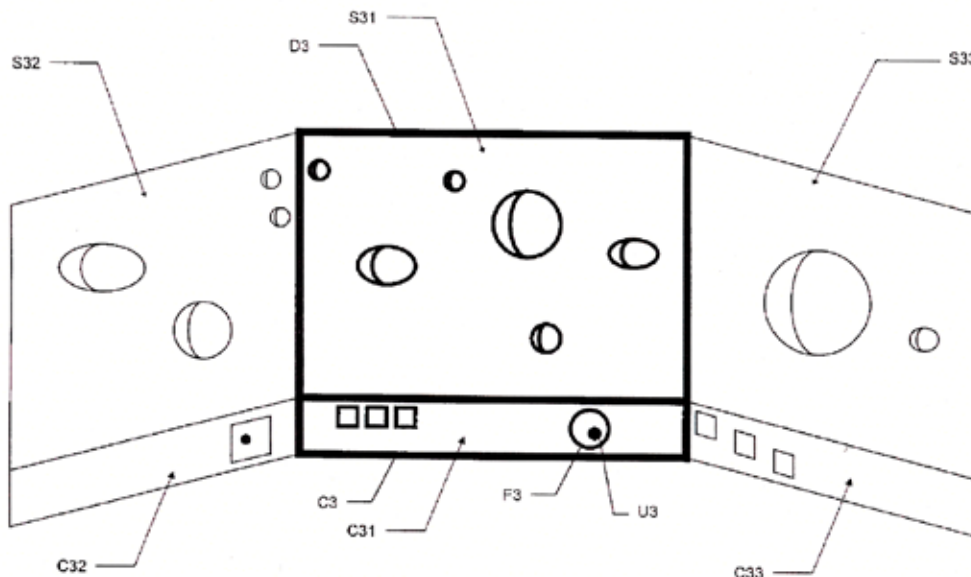

Appendix A



US006724400B1

(12) **United States Patent**
Anderson

(10) **Patent No.:** US 6,724,400 B1
(45) **Date of Patent:** Apr. 20, 2004

(54) **HUMAN-COMPUTER INTERFACE INCORPORATING PERSONAL AND APPLICATION DOMAINS**

(75) **Inventor:** Thomas G. Anderson, Albuquerque, NM (US)

(73) **Assignee:** Novint Technologies, Inc., Albuquerque, NM (US)

(*) **Notice:** Subject to any disclaimer, the term of this patent is extended or adjusted under 35 U.S.C. 154(b) by 665 days.

(21) **Appl. No.:** 09/649,853

(22) **Filed:** Aug. 29, 2000

Related U.S. Application Data

(60) Provisional application No. 60/202,448, filed on May 6, 2000.

(51) **Int. Cl.⁷** G09G 5/00

(52) **U.S. Cl.** 345/764; 345/762; 345/765; 345/802; 345/848; 345/850; 345/854

(58) **Field of Search** 345/744, 762, 345/764, 854, 733, 765, 778, 766, 848, 790, 850, 802; 709/328

(56) **References Cited**

U.S. PATENT DOCUMENTS

- 5,296,871 A 3/1994 Paley
- 5,459,382 A 10/1995 Jacobus et al.
- 5,506,605 A 4/1996 Paley
- 5,576,727 A 11/1996 Rosenberg et al.
- 5,588,105 A * 12/1996 Foster et al. 345/779

(List continued on next page.)

OTHER PUBLICATIONS

- <http://www.novint.com/links/publications/publications/html>, Novint technologies publications link.
- <http://haptic.mech.northwestern.edu/library>, Haptics community Web page.
- <http://www.cim.mcgill.ca/~haptic/publications.html>, Selected publications.

www.wsiwyg.com/main.15/http://marg.www...ple/marg/haptics-bibliography.html, Haptics bibliography.

<http://www.hitl.washington.edu/publications>, hit lab publications.

<http://www.caip.rutgers.edu/vrlab/pu-b.html>, Human-Machine Interface Lab.

<http://www.haptics-e.org>, Haptics-e, The Electronic Journal Of Haptics Research.

<http://intron.kz.tsukuba.as.jp/LHX/icat97.html>, A versatile software platform for visual/haptic environment, Hashimoto et al.

<http://www.novint.com/links/links.html>.

<http://www.novint.com/links/products/products.html>.

MUSE (Multidimensional, User-oriented Synthetic Environment), International Journal of Virtual Reality, vol. 1, No. 1, winter 1995.

Primary Examiner—Raymond J. Bayerl

Assistant Examiner—Cuong T. Thai

(74) *Attorney, Agent, or Firm*—V. Gerald Grafe

(57) **ABSTRACT**

The present invention provides a human-computer interface. The interface includes provision of an application domain, for example corresponding to a three-dimensional application. The user is allowed to navigate and interact with the application domain. The interface also includes a personal domain, offering the user controls and interaction distinct from the application domain. The separation into two domains allows the most suitable interface methods in each: for example, three-dimensional navigation in the application domain, and two- or three-dimensional controls in the personal domain. Transitions between the application domain and the personal domain are under control of the user, and the transition method is substantially independent of the navigation in the application domain. For example, the user can fly through a three-dimensional application domain, and always move to the personal domain by moving a cursor near one extreme of the display.

31 Claims, 8 Drawing Sheets

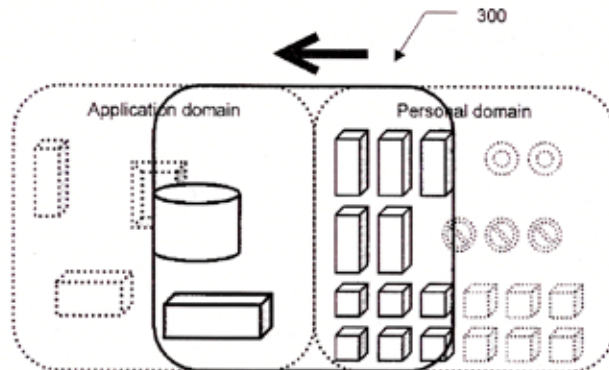

Appendix A



US006727924B1

(12) **United States Patent**
Anderson

(10) Patent No.: **US 6,727,924 B1**
(45) Date of Patent: **Apr. 27, 2004**

(54) **HUMAN-COMPUTER INTERFACE INCLUDING EFFICIENT THREE-DIMENSIONAL CONTROLS**

5,956,484 A 9/1999 Rosenberg et al.
6,028,593 A 2/2000 Rosenberg et al.
6,101,530 A 9/2000 Rosenberg et al.
6,125,385 A 9/2000 Wies et al.
6,131,097 A 10/2000 Peurach et al.

(75) Inventor: **Thomas G. Anderson**, Albuquerque, NM (US)

OTHER PUBLICATIONS

(73) Assignee: **Novint Technologies, Inc.**, Albuquerque, NM (US)

<http://www.novint.com/links/publications/publications.html>, Novint technologies publications link.

(*) Notice: Subject to any disclaimer, the term of this patent is extended or adjusted under 35 U.S.C. 154(b) by 505 days.

<http://haptic.mech.northwestern.edu/library>, Haptics community Web page.

(21) Appl. No.: **09/690,343**

<http://www.cim.mcgill.ca/~haptic/publications.html>, Selected publications.

(22) Filed: **Oct. 17, 2000**

<http://www.wsiwyg.com/main.15/http://marg.www...ple/marg/haptics-bibliography.html>, Hptics bibliography.

(51) Int. Cl.⁷ **G09G 5/00**

<http://www.hitl.washington.edu/publications>, hit lab publications.

(52) U.S. Cl. **345/851, 345/782, 345/836, 345/848, 345/850**

(List continued on next page.)

(58) Field of Search **345/782, 836, 345/848, 849, 850, 851, 852**

Primary Examiner—John W. Cabeca

Assistant Examiner—Brian Detwiler

(74) Attorney, Agent, or Firm—V. Gerald Grafe

(56) **References Cited**

U.S. PATENT DOCUMENTS

4,766,423 A	8/1988	Ono	
5,296,871 A	3/1994	Paley	
5,459,382 A	10/1995	Jacobus et al.	
5,506,605 A	4/1996	Paley	
5,555,366 A	9/1996	Teig	
5,576,727 A	11/1996	Rosenberg et al.	
5,629,594 A	5/1997	Jacobus et al.	
5,714,977 A	2/1998	McNeil	
5,734,373 A	3/1998	Rosenberg et al.	
5,734,805 A *	3/1998	Isensee et al.	345/419
5,739,811 A	4/1998	Rosenberg et al.	
5,781,172 A	7/1998	Engel	
5,784,052 A	7/1998	Keyson	
5,808,613 A *	9/1998	Marrin et al.	345/850
5,825,308 A	10/1998	Rosenberg et al.	
5,831,408 A	11/1998	Jacobus et al.	
5,844,392 A	12/1998	Peurach et al.	
5,874,956 A	2/1999	LaHood	
5,889,670 A	3/1999	Schuler et al.	
5,929,607 A	7/1999	Rosenberg	

(57) **ABSTRACT**

A method of human-computer interfacing provides efficient intuitive controls in a three-dimensional space. The method provides a three-dimensional space, characterized by a z dimension approximately parallel to the user's direction of view, and x and y dimensions approximately orthogonal thereto. A control has x and y coordinate sets, and a z coordinate set that spans a range of values. The range can be infinite, making the control accessible at all depths, or can be a finite range, making the control accessible from that range of depths. Movement of a cursor into the control's region initiates user interaction according to the control. The control depth reduces the precision of depth perception required to find the control. Once the user is in the control region, the effective depth for interaction can be relative to the depth when the user entered, providing control interaction independent of entering depth.

22 Claims, 5 Drawing Sheets

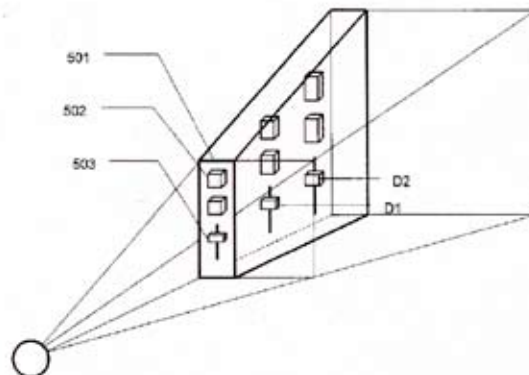

Appendix A

United States Patent [19]
Clavel

[11] **Patent Number:** 4,976,582

[45] **Date of Patent:** Dec. 11, 1990

[54] **DEVICE FOR THE MOVEMENT AND POSITIONING OF AN ELEMENT IN SPACE**

[75] **Inventor:** Raymond Clavel, Ecublens, Switzerland

[73] **Assignee:** Sogeva S.A., Switzerland

[21] **Appl. No.:** 403,987

[22] **Filed:** Sep. 6, 1989

Related U.S. Application Data

[63] Continuation of Ser. No. 96,113, Aug. 13, 1987, abandoned.

[30] **Foreign Application Priority Data**

Dec. 16, 1985 [CH] Switzerland 5348/85

[51] **Int. Cl.⁵** B25J 9/12

[52] **U.S. Cl.** 414/729; 901/23; 901/28; 248/179; 108/20; 108/138; 74/479

[58] **Field of Search** 414/728, 729, 735; 901/23, 24, 25, 28, 14; 248/179, 654; 108/201, 138; 74/479

[56] **References Cited**

U.S. PATENT DOCUMENTS

2,286,571	6/1942	Pollard	901/15
3,419,238	12/1968	Flory	248/163.1
4,407,625	10/1983	Shum	414/728
4,435,116	3/1984	Van Deberg	414/728
4,569,627	2/1986	Simunovic	414/735
4,651,589	3/1987	Lambert	901/22 X
4,712,971	12/1987	Fyler	414/744 R

FOREIGN PATENT DOCUMENTS

0422580 9/1974 U.S.S.R. 901/28

OTHER PUBLICATIONS

Mechanisms, Linkages, and Mechanical Controls, Nichols P. Chironis, copyright 1965, Scientific Library U.S. PTO, pp. 326-329.

Primary Examiner—Robert J. Spar
Assistant Examiner—Donald W. Underwood
Attorney, Agent, or Firm—William Brinks Olds Hofer Gilson & Lione

[57] **ABSTRACT**

The device comprises a base element (1) and a movable element (8). Three control arms (4) are rigidly mounted at their first extremity (15) on three shafts (2) which may be rotated. The three assemblies each formed by a shaft (2) and an arm (4) are the movable parts of three actuators (13) of which the fixed parts (3) are integral with the base element. The other extremity (16) of each control arm is made integral with the movable element through two linking bars (5a, 5b) hingedly mounted on the one hand to the second extremity (16) of the control arm and, on the other hand, to the movable element. The inclination and the orientation in space of the movable element remain unchanged, whatever the motions of the three control arms may be. The movable element supports a working element (9) of which the rotation is controlled by a fixed motor (11) situated on the base element. A telescopic arm (14) connects the motor to the working element.

25 Claims, 4 Drawing Sheets

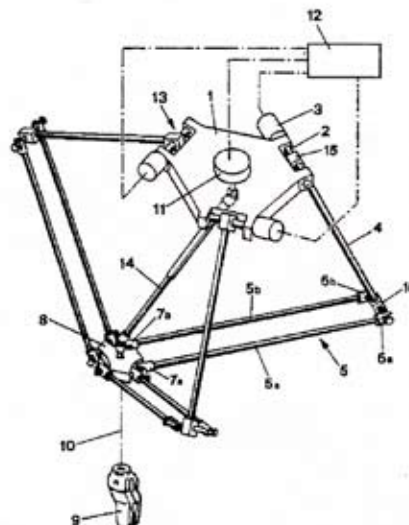

Appendix A



US006954899B1

(12) **United States Patent**
Anderson

(10) **Patent No.:** **US 6,954,899 B1**
(45) **Date of Patent:** **Oct. 11, 2005**

(54) **HUMAN-COMPUTER INTERFACE INCLUDING HAPTICALLY CONTROLLED INTERACTIONS**

(75) **Inventor:** **Thomas G. Anderson, Albuquerque, NM (US)**

(73) **Assignee:** **Novint Technologies, Inc., Albuquerque, NM (US)**

(*) **Notice:** Subject to any disclaimer, the term of this patent is extended or adjusted under 35 U.S.C. 154(b) by 525 days.

(21) **Appl. No.:** **09/785,696**

(22) **Filed:** **Feb. 16, 2001**

Related U.S. Application Data

(63) Continuation-in-part of application No. 08/834,642, filed on Apr. 14, 1997, and a continuation-in-part of application No. 08/834,616, filed on Apr. 14, 1997, now Pat. No. 6,208,349.

(60) Provisional application No. 60/202,448, filed on May 6, 2000.

(51) **Int. Cl.⁷** **G06F 3/00; G06F 3/033; G09G 5/08**

(52) **U.S. Cl.** **715/701; 715/702; 715/765; 715/784; 715/858; 715/862; 345/157**

(58) **Field of Search** **345/702, 701, 345/700, 856, 862, 858, 861, 156, 163, 159, 345/157; 715/700-702, 764, 765, 784, 786, 715/808, 828, 830, 856, 858, 861, 862, 973, 715/977**

(56) **References Cited**

U.S. PATENT DOCUMENTS

- 4,766,423 A 8/1988 Ono
- 5,296,871 A 3/1994 Paley
- 5,459,382 A 10/1995 Jacobus et al.
- 5,506,605 A 4/1996 Paley
- 5,555,366 A 9/1996 Teig

- 5,576,727 A 11/1996 Rosenberg et al.
- 5,629,594 A 5/1997 Jacobus et al.
- 5,714,977 A 2/1998 McNeil
- 5,734,373 A 3/1998 Rosenberg et al.
- 5,734,805 A 3/1998 Isensee
- 5,739,811 A 4/1998 Rosenberg et al.
- 5,781,172 A 7/1998 Engel
- 5,784,052 A 7/1998 Keyson
- 5,825,308 A 10/1998 Rosenberg et al.
- 5,831,408 A 11/1998 Jacobus et al.
- 5,844,392 A 12/1998 Peurach et al.
- 5,874,956 A 2/1999 LaHood
- 5,889,670 A 3/1999 Schuler et al.
- 5,929,607 A 7/1999 Rosenberg
- 5,956,484 A 9/1999 Rosenberg et al.

(Continued)

OTHER PUBLICATIONS

<http://www.novint.com/links/publications/publications.html>, Novint technologies publications link.

(Continued)

Primary Examiner—X. L. Bautista

(74) *Attorney, Agent, or Firm*—V. Gerald Grafe

(57) **ABSTRACT**

The present invention provides a method of human-computer interfacing that provides haptic feedback to control interface interactions such as scrolling or zooming within an application. Haptic feedback in the present method allows the user more intuitive control of the interface interactions, and allows the user's visual focus to remain on the application. The method comprises providing a control domain within which the user can control interactions. For example, a haptic boundary can be provided corresponding to scrollable or scalable portions of the application domain. The user can position a cursor near such a boundary, feeling its presence haptically (reducing the requirement for visual attention for control of scrolling of the display). The user can then apply force relative to the boundary, causing the interface to scroll the domain. The rate of scrolling can be related to the magnitude of applied force, providing the user with additional intuitive, non-visual control of scrolling.

22 Claims, 3 Drawing Sheets

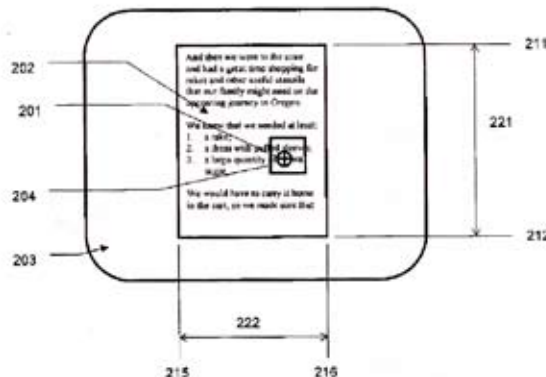

Appendix B: EXAMPLES OF HOW THE NOVINT FALCON IS USED IN VIDEO GAMING

Use your sense of touch and the Novint Falcon to put a little English on the ball, tap a short volley, smash home a return shot, or hit a lightning fast serve. With the Falcon, you control the strength and direction of a hit, as well as the amount of spin on the ball. Actually feel the weight and inertia of the paddle as you swing your way to victory. Finesse or power, it's your choice with the Novint Falcon.

NOVINT

FEELIN' IT: TABLE TENNIS™



Features

- Brings a classic game to life: For the very first time, you can have the same experience of table tennis on a computer that you had as a kid playing with friends or siblings. The Falcon takes this timeless concept and turns it into a modern classic for the next generation of gamers. Move your paddle in full 3D, actually feel the ball hit the paddle's surface, undercut the ball to put spin on it — it's the most realism you can get without buying an actual table.
- Pick up and play: The Falcon's 3D range-of-motion, realistic force feedback, and intuitive controls make learning to play simple and fun. While friends will love playing at a party on a beginner level, Feelin' it: Table Tennis has enough precision and control that you can develop the same level of skill requirements and muscle memory that a real-life pro needs.
- Tons of options: A variety of difficulties, a training mode, a bracket competition mode, networked multiplayer support, and different paddles provide hours of fun gameplay. Like real life table tennis, no matter how much you play, it never gets old.

Appendix B: EXAMPLES OF HOW THE NOVINT FALCON IS USED IN VIDEO GAMING

You'll actually be able to tell the difference between weapons just by feeling their weight and recoil: the shotgun feels heavy with a hard kickback, while the automatic rifle feels lighter with shorter bursts of fire.

And that's just the beginning. Use your sense of touch to wreak havoc behind the wheel of a jeep, toss around barrels and boxes with your hands or with the gravity gun, and smash down barricades with the mighty crowbar.

NOVINT

HALF-LIFE® 2 DRIVERS



Features

- Heightened gameplay: With the Novint Falcon, Half-Life 2 becomes the game that first-person shooter fans have always dreamed of. Our drivers take the already incredible gameplay of HL2, and make it even better by adding a level of realism that gives you the feeling you're really there. You'll actually feel like YOU are being attacked, rather than the character – it will blow you away.
- Solid controls and enhanced feedback: With the 3D motion of the Novint Falcon, your control of your movement is as intuitive and fast as the mouse, with the addition of precise, sophisticated feedback. The Falcon's feedback allows you know instinctively where enemy fire originates, and how badly you were hit. The Falcon lets you know how hard your jeep is struck, and its 360 degree forces let you determine intuitively whether the vehicle will land upright if you roll it. If a barrel explodes in front of you, it will feel fundamentally different than if you're hit with bullets, or if a Barnacle chomps down on you from above. When was the last time your mouse did all that?
- Adds life to a classic: Already love HL2? Try the Novint Falcon Drivers and you'll fall in love all over again. It will seem like a completely different game – it's like adding color to a classic black and white film.

Appendix B: EXAMPLES OF HOW THE NOVINT FALCON IS USED IN VIDEO GAMING

For the first time, use your sense of touch to jam with some rockin' tunes and turn your living room into a head-banger's paradise. Match your drum beats with the flashing sparks while keeping time with the rhythm of the music. Hit the correct drum in sync with the song and you'll rack up points and move on. Mess up too many times and you'll be sent packing. Actually feel the drumstick hit its mark and watch the crowd go wild. Catch the beat!

NOVINT

TOP BEAT



Features

- As real as it gets: The Novint Falcon lets you actually feel the drumstick hit the skins.
- Combines quick reflex action with high-energy music for exciting fun. If you have rhythm, you'll love this game. If you don't have rhythm, you'll learn it here, and then you'll love this game.
- Includes multiple difficulty modes and drum techniques for gamers of all skill levels.

Appendix B: EXAMPLES OF HOW THE NOVINT FALCON IS USED IN VIDEO GAMING

As Roly Poly Rolland, you'll roll your way through a fun and tricky environment in this challenging race against the clock! With the Falcon, you'll be able to actually feel your way through the course instead of simply watching, giving you more realism and more fun as you roll. Feel Rolland bump down stairs, fly from a ramp, twirl through a loop-dee-loop, bounce from a bumper, blast from a cannon, and be pushed by a giant fan. The Falcon makes controlling your momentum intuitive and exciting as you avoid the cliff's edge in your race to collect food and coins.

NOVINT

ROLY POLY ROLLIN'™



Features

- **Innovative controls:** The Falcon makes rolling your way through Rolland's world intuitive and natural. If you've ever played games where you roll a character past obstacles before, you'll never go back to the old way of playing again once you feel your motion and momentum with the Falcon.
- **Easy to learn, hard to master:** With the Falcon, controlling your movement is second nature, but the exciting world of Roly Poly Rollin' offers a challenge sure to entertain all skill levels. Every bump and jolt feels so realistic, you'll start to believe that you ARE Rolland rather than simply controlling him.
- **Family fun:** From kids to adults, everybody loves rollin' Roly Poly Rolland.

Appendix B: EXAMPLES OF HOW THE NOVINT FALCON IS USED IN VIDEO GAMING

In this fast-paced racing challenge, you will use your sense of touch to pilot your speeder across 50 stages of multi-level madness filled with rewards and hazards. To win each challenge, you will need to grab powerups and gems, use your rocket boost to blast from one platform to another, avoid pitfalls, and destroy the swarms of enemies in your path. With the Novint Falcon at your command, you'll feel every impact, boost, jolt, and blast. And the Falcon's 3D movement makes precise aiming and split-second steering a breeze.

NOVINT

IMPULSE THRUSTER™



Features

- **Intuitive controls:** With the Novint Falcon, you can guide your racer intuitively, using your sense of touch to feel your thruster fire, landing on platforms, force impacts, and guns blazing. Plus, the Falcon's 3D range-of-motion is much more natural than pushing around a 2D mouse on your desktop.
- **Frenetic action:** Fast-paced racing combines with unique, multi-leveled environments to create an exciting and one-of-a-kind gaming experience. Forget bio breaks – you won't have time.
- **Extended Immersive gameplay:** With 50 unique stages, Impulse Thruster provides hours of gameplay where you'll feel like you are actually there rather than simply pushing buttons to control your character.

Appendix B: EXAMPLES OF HOW THE NOVINT FALCON IS USED IN VIDEO GAMING

You've never done puzzles like this before! Find a solution using three-dimensional control as you toss colorful blocks to complete a series of 3D underwater brainteasers. Place three or more cubes of the same color together and they will disappear from the environment and reveal the next color. Look at upcoming cube colors to plot your strategy towards victory. All the while, you'll be able to actually feel the weight of the cubes and the force of the waves as you glide the pieces into place. Use quick thinking and the intuitive Falcon controls to solve the riddles of Aquatreous.

NOVINT

AQUATREOUS TM



Features

- **Puzzles with a twist:** With the Novint Falcon, you can actually feel the puzzle pieces as you push them into place. Also, because the puzzles are 3-dimensional structures, the Falcon's 3D range-of-motion allows you to position each piece with ease.
- **Family fun:** Anyone can enjoy the addictive puzzles of Aquatreous. You'll find yourself saying, "Just one more level..." over and over again.
- **Diverse gameplay:** With nearly 200 unique puzzles, Aquatreous provides hours of fresh gameplay. Some levels require you to search your way through correct positioning with a never-ending supply of cubes, while others require you to place a very limited number of cubes in precise positions to find a solution to a difficult puzzle. The landscape of your puzzle can change in an instant, as multiple levels collapse, or you might find yourself racing to finish the puzzle before more blocks are added by the sneaky shark. If you like puzzles, solitaire, match-3 games, or mah jong you'll love Aquatreous.

**APPENDIX C: AWARDS, MEDIA
COVERAGE, PRESS RELEASES**



Recent Awards

- FEDERAL LABORATORY CONSORTIUM FOR TECHNOLOGY TRANSFER (FLC).

“Novint’s 3D Haptic Technology Software” has been selected as a winner of the 2007 Award for Excellence in Technology Transfer.

A distinguished panel of technology transfer experts from industry, state, and local government, academia, and the federal laboratory system evaluated the nominations.

NOVINT FALCON WINS IGN BEST OF E3: GEAR AWARD

In a category that included the Nintendo Wii-mote, a PS2 controller, and the Playstation 3 controller, IGN has awarded the Novint Falcon their Best of E3: Gear Award.

Recent Media Coverage

<http://www.novint.com/news.htm>

Falcon Named One of Top 5 Coolest Gadgets at CES by TechEBlog

“We demoed the Falcon with Half-Life 2 and were blown away. Shotgun blasts produced hard, lurching recoil, while automatic machine gun fire was fast and light with an upward pull on the handle, simulating the barrel-rise effect of automatic fire...”

TechEBloglick

“We saw a lot of controllers at CES, but the Novint’s Falcon stood out from the crowd...”

[Gizmodo](#): Hands on with Novint’s 3D Game Controller, January 15, 2007

“The Falcon delivers what it promises, a chance to really feel what is going on in a game...”

[Ventura County Star](#): New controls work to enrich experience, January 12, 2007

APPENDIX C: AWARDS, MEDIA
COVERAGE, PRESS RELEASES

"I was very surprised at how easy it was to use, and how it impacted the overall feel of the game. It provided a very different experience to Half-Life 2 and I believe I would actually enjoy playing it again..."

[BCCHardware](#): Kicking Things Up at CES! Zeus Day 4, January 11, 2007

"The Novint Falcon is a first-of-a-kind input device that makes virtual items "feel" like solid objects; gamers can experience weight, shape, texture, dimension and force effects in supported games..."

[PC World](#): CES Video: CES Video: 3D Touch Controller Lets you Feel Game, January 10, 2007

"Novint Falcon offers true force feedback like no other gaming peripheral..."

[Firing Squad](#): CES: Novint Falcon Update, January 9, 2007

"Non-Nintendo gamers jealous of the console's infamous wand will soon be able to go one better..."

[Tech.co.uk](#): CES: 2007 Wii-style control for PC Games, January 9, 2007

"The real kicker is the force feedback that's been worked into this thing, adding a pretty nifty layer of interactivity — you know, gun recoil, rubber band snapping, the feel of textures against the skin, stuff like that..."

[engadget](#): Novint Falcon crazy mouse gets a price, release date, January 9, 2007

"Nintendo has proved with Wii and DS that how you physically interact with a game is every bit as important as the title itself. And the new Falcon controller has taken this ethos onboard with fanatical focus, and kicked out some truly astonishing results..."

APPENDIX C: AWARDS, MEDIA
COVERAGE, PRESS RELEASES

[T3: Forget Wii!](#) *Gaming enters a new dimension,*
January 8, 2007

"A first-person shooting game makes one feel the impact when the character whacks a crowbar against a wall, or the recoil from a shotgun when firing at an enemy. It's so real, it's hard not to feel a pang of guilt when splattering foes..."

[Associated Press](#): *CES Notebook: Mouse jiggles to games,*
January 8, 2007

"If you think the Wiimote feels good with its reactive vibrations and sounds, then you will be amazed with the Novint Falcon game controller..."

[Slashgear.com](#), [CES 2007](#): *Novint Falcon Game Controller Feels Real Good,*
January 7, 2007

Senior Editor Tekla Perry of IEEE Selects Falcon as CES Winner
[IEEE Spectrum online](#), CES
January 7, 2007

"Novint's haptic controller, the Falcon, looks set to revolutionize gaming."

[BusinessWeek](#), *Will the Mouse Feel Falcon's Talons?*,
August 29, 2006

"With its alien-like silhouette and haptic technology, the Falcon represents a fresh direction in PC game peripherals."

[BusinessWeek](#), *Haptic Days to Come?*,
August 29, 2006

"After I peeled my jaw off the floor, I realized that this product was going to change the way we all live in a fundamental and beautiful way...once you touch a virtual object and feel its physical contours, you'll never quite think about virtual reality the same way again."

APPENDIX C: AWARDS, MEDIA
COVERAGE, PRESS RELEASES

[Millions of Us](#), *The Second Half of Second Life: Haptics*,
August 5, 2006

"What blew us away, though, was something hiding in Kentia Hall — the slum of E3 — in an unassumingly small booth drawing a huge crowd. Forget Nintendo's Wii-mote; Novint Technologies' Falcon is a three dimensional controller that adds a whole new layer to gaming."

[Computer Gaming World](#), *Best Peripheral Ever*,
July 2006

"For most gamers, the first truly sophisticated haptic controller will be the Novint Falcon...It got rave reviews when it was demoed in May at the E3 computer games expo in Los Angeles."

[New Scientist](#), *Gadgets get the feel of the tactile world*,
July 14, 2006

"Force-feedback game controllers are nothing new, but we're smitten with the Novint Falcon..."

[PC Magazine](#), *3D Touch Controller*,
June 21, 2006

"My hands-on time with the Falcon was nothing short of mind-blowing. Even the simplest game became mesmerizing with the technology of the Falcon."

[The Alibi](#), *Bird of Prey - Introducing the Novint Falcon*,
June 15, 2006

"I recently had a hands-on experience with the Novint Falcon, a completely new interface device from Novint Technologies, - and was absolutely blown away, damn near left speechless."

[Resident Gamer](#), *Novint Falcon: Convincing 3D Touch Technology*, June 12, 2006

APPENDIX C: AWARDS, MEDIA
COVERAGE, PRESS RELEASES

"The Novint Falcon is one of the most promising PC interface peripherals to come along in years...Were the Falcon simply one of the most intuitive 3D controllers ever produced, that would be appealing enough, but the product also incorporates sophisticated haptics or advanced force-feedback..."

[engadget](#), *Switched On: Taking control to another dimension:*
June 7, 2006

"The Nintendo Wii made a big splash at E3 this year, and its motion-tracking controller has suddenly pushed innovative control mechanics into the forefront of what's hot in gaming. While we are fans of going through physical motions to play games with the Wii, Novint Technologies opened our eyes to what it's like to actually feel a game...We were blown away and can hardly wait for Novint to make good on their promise to launch the Falcon in 2007..."

[IGN](#), *Best of E3: Gear - Novint Falcon 3D Touch Controller:*
May 19, 2006

"Coolest Thing At E3...It's not Spore. It's not the Nintendo Revolution. It's not the Burning Crusade. The coolest thing at E3 was way down in the bowels of Kentia Hall, made by a company we'd never heard of: Novint Technologies. It probably had the biggest crowd of all the little booths up and down the cramped aisles of Deep Kentia..."

[F13.net](#) *E3 2006: Coolest Thing At E3:*
May 13, 2006

"Think the Wii's remote is innovative? Get ready for haptic (3D touch) that'll blow your mind."

[IGN](#), *E3 2006: Novint Falcon Hands-On Report:*
May 12, 2006

APPENDIX C: AWARDS, MEDIA
COVERAGE, PRESS RELEASES

"While most people at E3 are bumping into each other in the South and West Halls, some of the most interesting and innovative products are being showcased in Kentia Hall. I headed down there after lunch and stopped to check out the Novint Falcon, and I was absolutely blown away by this thing."

[E3 Insider](#), *Hidden Gems in Kentia Hall*:

May 11, 2006

"The Novint Falcon 3D Controller from Novint Technologies is a bold and unique new controller that will give gamers the ability to feel and play games in a fully realized 3D space..."

[UPI](#), *Its a Wrap, GDC top 12 list*:

March 24, 2006

"Nintendo made huge waves with their new Revolution controller, but that controller pales in comparison to Novint Technologies, Inc., a small company with big ideas, which has created a new interactive 3D touch pad called the Novint Falcon."

[UPI](#), *Game Developers Converge on San Jose*:

March 22, 2006

"It's far more sophisticated than the joy-buzzer (force-feedback)" in today's console controllers."

[Popular Science Magazine](#), *What's New*:

May 2005

"Coolest among the new gadgets was the Falcon..."

[Wall Street Journal](#), *High Tech Show Highlights*:

February 17, 2005

"One of the top 5 Demo Favorites that 'transcended the ordinary'."

[San Jose Mercury News](#), *Tech Gadgets in the Pipeline at DEMO*:

February 16, 2005

**APPENDIX C: AWARDS, MEDIA
COVERAGE, PRESS RELEASES**

"One of the most viscerally interesting at Demo."

Wired, *Fast Moving Tech at DEMO*:

February 16, 2005

Videos and Podcasts

BAMCAT.com Big screens, XBOX IPTV, and a couple of cool joysticks!, January 8, 2007

BlipTV The Bleeding Edge, January 8, 2007

C/NET video featuring Andrea Bellmont, January 7, 2007

CNN's Renay San Miguel showcases the Falcon (2nd segment), January 7, 2007

HowStuffWorks video featuring Antonia Chappell, May 16, 2006

Gamespot video featuring Antonia Chappell, May 12, 2006

Gamer Andy podcast featuring Bill Anderson, May 12, 2006

Gizmodo video featuring Bill Anderson, May 10, 2006

More News

Novint Falcon: Convincing 3D Touch Technology, Resident Gamer, June 12, 2006

Tech Toys on Way for Holidays: Red Herring, June 7, 2006

DigitalLife Press Preview: 3D Controllers, Entertainment

Systems, and More: Gearlog.com, June 6, 2006

Electronic Entertainment Expo 2006 Video Tour: How Stuff Works, May 16, 2006

**APPENDIX C: AWARDS, MEDIA
COVERAGE, PRESS RELEASES**

Novint Falcon shows 3D touch in gaming, Videogamesblogger.com, May 15, 2006

E3: Edie's Fave Gadgets, Part 1, Gamer Andy, May 15, 2006

E3: Extreme Tech Reports on the Best Gadgets: GearLog, May 11, 2006 (photo)

\$100 3D Haptic Mouse Next Year: 3point3.com, May 10, 2006

How We Got the Money--Novint: Instead, We Went Public: Innovation, April/May 2006

The State of Virtual Reality: Newsfactor.com, March 24, 2006

GDC: 06 Day 1: Techgage.com, March 22, 2006

Novint Falcon Interview: Firingsquad.com, March 22, 2006

Novint Falcon Gets a New Look: Forbes.com, March 21, 2006

Demo Offers Glimpse Into Future: CNN, February 18, 2005

Tech to Touch and Be Touched: CBS News, February 17, 2005

A Little of Everything Turns Up At Demo: USA Today, February 17, 2005

Novint Unveils 3D Computer controller: New Mexico Business Weekly, February 17, 2005

Invention Mania: Associated Press, February 16, 2005

Consumer Products Wow The Crowd: PC World, February 16, 2005

Getting Touchy Feely With Gamers: C/NET, February 15, 2005

No Lack of Cool at DEMO: NetworkWorldFusion, February 14, 2005

DEMO 2005 Sneak Peek: PC Magazine, February 14, 2005

Virtual Ultrasound: 2002 Best Invention, Time Magazine, November 11, 2002

**APPENDIX C: AWARDS, MEDIA
COVERAGE, PRESS RELEASES**

Recent Press Releases

January 8, 2007 -- CES 2007: Novint Technologies Announces Availability of Limited Edition Novint Falcon 3D Touch Game Controller

November 14, 2006 -- VTech to Manufacture Novint Falcon

November 8, 2006 -- Novint Falcon Named Innovations 2007 Design and Engineering Award Honoree by CEA

June 8, 2006 -- Novint Technologies Announces Initial Public Offering

May 9, 2006 -- Novint Brings 3D Touch to Games at E3 Expo

March 21, 2006 -- Novint Falcon Gets a New Look

February 14, 2005 -- Novint Falcon Brings Interactive 3D Touch to Computers

January 13, 2005 -- Novint to launch at DEMO

November 11, 2002 -- e-Touch sono Time Magazine's Coolest Inventions



Sandia is a multiprogram laboratory operated by Sandia Corporation,
a Lockheed Martin Company, for the United States Department of Energy's
National Nuclear Security Administration under contract DE-AC04-94AL85000.
SAND2007-1197P Designed by Creative Arts Dept. (505) 844-9011. SP•110397•03/07

