



REPORT OF APOLLO 204 REVIEW BOARD

**TO
THE ADMINISTRATOR
NATIONAL AERONAUTICS AND SPACE ADMINISTRATION**

**APPENDIX C
SECTION 2**



SYSTEMS DATA

SECTION 2

SUBSECTION 2.9

SEQUENTIAL SYSTEMS

2.9.1 INTRODUCTION.

The sequential systems consist of control and detection systems which function during ascent and entry portions of a mission or in pre-orbital aborts. The control functions are sensing L/V status, displaying L/V status to the crew, automatically initiating LES aborts in an emergency during early ascent, and automatically sequencing the ELS during descent. Backup controls are provided for critical functions and normal events. The systems are the sequential events control system (SECS), emergency detection system (EDS), launch escape system (LES), and earth landing system (ELS). The systems interface with the reaction control system (RCS), guidance and navigation (G&N), service propulsion system (SPS), stabilization and control system (SCS), electrical power system (EPS), telecommunications (T/C), and controls and displays (C&D).

2.9.2 FUNCTIONAL DESCRIPTION.

The purpose of the sequential systems is to provide safety for the crew during the ascent and descent phases of a mission, and to perform normal separation functions. The EDS monitors operation of the L/V and will initiate an automatic abort in an emergency. The LES is provided for use during an emergency arising from malfunction of the L/V or other systems affecting crew safety. The LES will be utilized to abort the mission in an emergency by separating the C/M from the L/V and S/M. The LES can be operational from the launch pad until the launch escape tower is jettisoned. Following second stage booster ignition, the LES tower is jettisoned from the CSM-L/V combination. The ELS is provided to stabilize and decelerate the C/M following an entry into the earth atmosphere or following an abort. The ELS parachutes will lower the C/M at a suitable velocity and attain a safe landing. A functional description of the sequential systems is contained in the following paragraphs.

2.9.2.1 Sequential Events Control System (SECS).

The SECS consists of controllers (figure 27-8-1) that provide automatic, semiautomatic, and manual control for initiation or termination of functional events during various phases of the Apollo mission. The controllers are the master events sequence controller (MESC), earth landing sequence controller (ELSC), C/M reaction control system controller (C/M-RCS), service module jettison controller (SMJC). Each

SEQUENTIAL SYSTEMS

SM2A-03-SC012
 APOLLO OPERATIONS HANDBOOK

SYSTEMS DATA

controller consists of redundant relays, timers, and other devices to control systems operation and automatic timing of events. Two controllers are provided in all cases for dual redundancy. The SECS will control the automatically sequenced events during a mission abort, normal CSM-SLA separation, normal C/M-S/M separation, and events during the earth landing phase. The SECS provides conditioned signals to telemetry equipment through the data distribution box so that vital information may be telemetered to MSFN.

The SECS will control the launch escape system (LES) during an abort up to the time of normal launch escape tower jettison. The SPS engine is utilized during an abort after LES tower jettison to propel the CSM away from the L/V. Normal separation of the SLA is performed by the SECS following manual initiation after earth orbit is attained. Emergency separation of the SLA is performed automatically 1.7 seconds after an SPS abort is manually initiated. C/M-S/M separation is performed by the SECS, and is manually initiated during the entry phase or subsequent to an SPS abort. During a LES abort, the C/M-S/M separation is performed automatically by the SECS. Events performed by the earth landing system are automatically controlled by the SECS during normal descent. Switches are provided for manual backup of critical events.

The basic functions performed by the SECS are as follows:

Event	Originates	Function/Input	Manual Control
Auto abort enable	MESC	Lift-off signal	EDS AUTO switch (MDC-16)
LE and PC motors fire	MESC	C/M-S/M separation relays	LES MOTOR FIRE switch (MDC-5)
Pitch motor inhibit	C/M RCSC	Lift-off + 61 seconds	ABORT SYSTEM-OX DUMP switch (MDC-16)
Auto RCS oxidizer dump inhibit	C/M RCSC	Lift-off + 61 seconds	ABORT SYSTEM-OX DUMP switch (MDC-16)
LES tower jettison	MESC	ELS armed and 24K ft baroswitch closure on LES aborts, manual 3 minutes after lift-off	ABORT SYSTEM-MODE switches A and B (MDC-16)
CSM-SLA separation	MESC	Translation control + 1.7 seconds	ADAP SEP switch (MDC-5)

SEQUENTIAL SYSTEMS

SM2A-03-SC012
 APOLLO OPERATIONS HANDBOOK

SYSTEMS DATA

Event	Originates	Function/Input	Manual Control
RCS/SCS enable	MESC	Adapter separation + 2.5 seconds or C/M-S/M deadface + 1 second	REACTION CONTROL SYSTEM-CMD switch (MDC-16)
LES abort initiation	MESC	EDS abort signal from L/V-IU	Translation control
C/M-S/M separation	MESC	C/M-S/M deadface relays + 0.1 second	C/M-S/M SEP switches A and B (MDC-15)
Canard deploy	MESC	LES abort lockup relays + 11 seconds	CANARD DEPLOY switch (MDC-5)
SPS abort initiation	MESC	Manual	Translation control
RCS/SCS disable	MESC	ELS armed and 24K ft baroswitch closure	REACTION CONTROL SYS-CMD switch (MDC-16)
Apex cover jettison	MESC	ELS armed and 24K ft baroswitch closure + 0.4 second	APEX COVER JETT switch (MDC-5)
Drogue parachutes deploy	ELSC	ELS armed and 24K ft baroswitch closure + 2 seconds	DROGUE DEPLOY switch (MDC-5)
Drogue parachutes release and main parachutes deploy	ELSC	ELS armed and 24K ft baroswitch closure + 14 seconds + 10K ft baroswitch closure	MAIN DEPLOY switch (MDC-5)
RCS propellants burn	C/M RCSC	Manual	C/M PROP JETT DUMP switch (MDC-8)
RCS purge	C/M RCSC	Manual	C/M PROP JETT PURGE switch (MDC-8)

SEQ

SEQUENTIAL SYSTEMS

SM2A-03-SC012
 APOLLO OPERATIONS HANDBOOK

SYSTEMS DATA

Event	Originates	Function/Input	Manual Control
Main parachutes release	ELSC	Manual	MAIN CHUTE release switch (MDC-16)
Postlanding antenna deploy	MESC	Manual	POST LANDING-ANTENNA-DEPLOY switches A and B (MDC-25)

2.9.2.2 Emergency Detection System.

The EDS is designed to detect and display status and emergency conditions of the launch vehicle-spacecraft combination to the astronaut. The EDS also provides automatic abort initiation, under certain conditions, after lift-off up to the normal time of LES tower jettison.

The EDS display circuitry is enabled when the EDS POWER switch (MDC-24) is in the ON position and will illuminate lights on MDC-5 to indicate L/V status. The red L/V RATE light will illuminate when L/V rates are in excess of 20 degrees per second in roll and 5 degrees per second in pitch and yaw. The rates are sensed by three rate gyros mounted on each L/V axis in the instrumentation unit (IU). The red L/V GUID light (MDC-5) illuminates to indicate failure of the guidance unit which is also located in the instrumentation unit. The yellow L/V ENGINES lights (MDC-5) illuminate when a respective S-I booster engine is developing less than 90 percent of total thrust output. The L/V ENGINES lights are monitored for engine status during thrusting periods. During staging, the L/V ENGINES lights are monitored for illumination to indicate BECO and extinguish to indicate stage separation. After staging, the number 1 L/V ENGINE light indicates the status of the S-IVB Stage engine, it will be extinguished when the engine is producing 65 percent rated thrust. The ABORT light (MDC-3) is a red lamp assembly containing 4 bulbs. Two bulbs are in system A and two bulbs are in system B for redundancy. The ABORT light is illuminated if an abort is requested by launch control center for a pad abort or an abort during lift-off via radio. The ABORT light can be illuminated after lift-off by the Range Safety Officer transmitting a destruct arm command. The destruct arm command will also initiate BECO. An abort may also be requested via radio from the MSFN after lift-off +10 seconds.

The EDS automatic abort circuitry is enabled at lift-off providing the EDS AUTO switch (MDC-16) is in the AUTO position. (See figure 2.9-2.) A circuit is completed through the lift-off enable and first motion relays at lift off. The lift-off enable relays are latching

SEQUENTIAL SYSTEMS

SM2A-03-SC012
APOLLO OPERATIONS HANDBOOK

SYSTEMS DATA

type and are latched closed by GSE just prior to lift-off. The normally closed first motion relays remain energized by GSE until actual lift-off occurs. A circuit is completed through the relays and the EDS AUTO switch upon lift-off. The white LIFT-OFF light (MDC-5) illuminates and the red NO AUTO ABORT light (MDC-5) should remain extinguished. The astronaut presses the NO AUTO ABORT switch-light if it illuminates. The NO AUTO ABORT switch-light should also be pressed if the LIFT OFF light does not illuminate at lift-off. This would indicate that the circuit was not completed for illuminating the LIFT OFF light and energizing the auto abort enabling relays. Pressing the NO AUTO ABORT switch-light will energize the auto abort enabling relays through circuitry in the MESC. The EDS AUTO switch must be at AUTO to complete the circuit. The LIFT OFF light would not illuminate in this case. (Refer to Malfunction Procedures in section 9.) The LIFT OFF light is extinguished by circuitry in the L/V IU at approximately 5 seconds after illumination at lift-off. The EDS will automatically initiate an abort when two L/V engines fail or L/V excessive rates are sensed if these two functions are enabled. The two functions are enabled with the ABORT SYSTEM - 2 ENG OUT switch (MDC-16) and ABORT SYSTEM - RATES switch (MDC-16). The two switches are set to off to inhibit the two functions prior to S-IB staging. L/V guidance failure will not initiate an automatic abort. The crew will contact MSFN and a decision made on the action to be taken. If a destruct arm command is transmitted prior to inhibiting the two-engine out auto abort capability, the EDS will detect BECO and initiate an automatic abort. If a destruct arm command is transmitted after the two-engine out auto abort capability is inhibited, a manual abort must be initiated immediately when the ABORT light illuminates. Structural breakup or separation of the structure between the IU and C/M will also be detected by the EDS and an automatic abort initiated. During ascent on a normal mission, the EDS AUTO switch must be set to OFF prior to launch escape tower jettison. Inhibiting of the auto abort capability ensures that an automatic abort can not be initiated at the same time that the launch escape tower is being jettisoned. An abort may be initiated manually by rotating the commander's translation control to the counterclockwise detent position (20 degrees).

The parameters being sensed by the EDS are extremely time-critical at various periods during the boost phase. When these parameters are exceeded, an LES abort is automatically initiated to propel the escaping vehicle (C/M and LES) safely away from the launch vehicle prior to a catastrophic condition. Concurrently with abort initiation, either automatically or manually, logic circuitry will shut down engines in the L/V activate stage. The engine shutdown signal is inhibited by circuitry in the IU for the first 40 seconds of launch because of range safety restrictions.

A Q-ball (figure 2.9-3) mounted above the LES motors, provides an electrical signal input to the L/V AOA/SPS P_C indicator on MDC-3 and an electrical signal input to ground control via telemetry.

SEQUENTIAL SYSTEMS

Mission _____ Basic Date 12 Nov 1966 Change Date _____ Page 2.9-9

SYSTEMS DATA

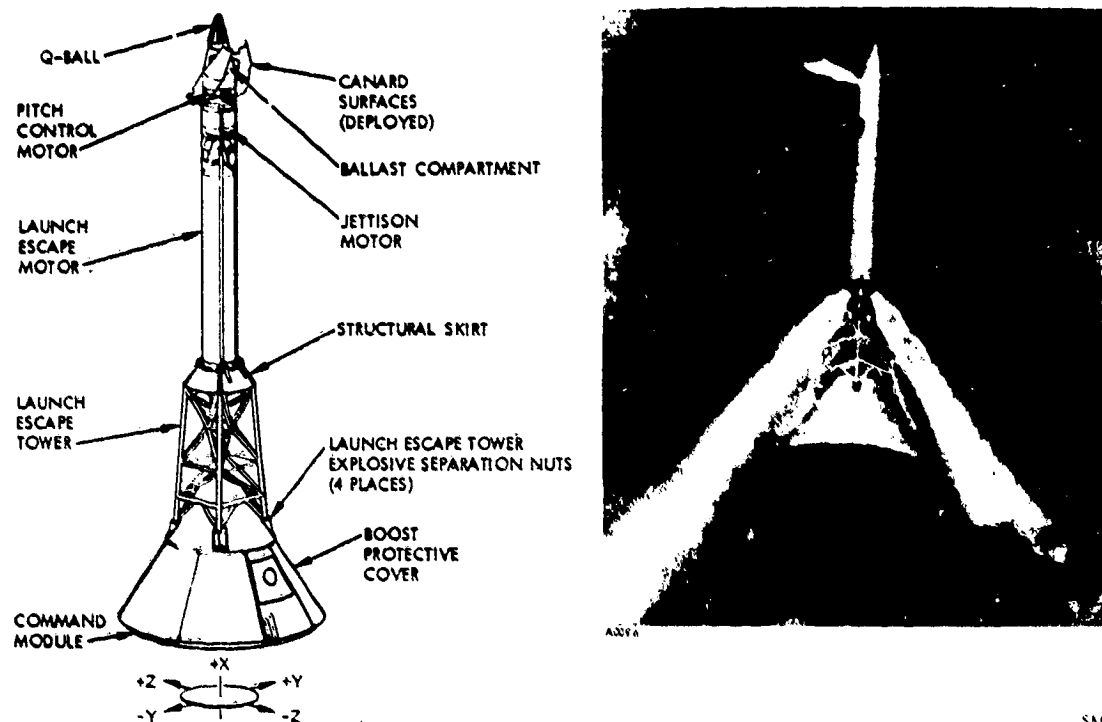

Figure 2.9-3. Launch Escape System

The Q-ball has four static ports for measuring ΔP which is a function of angle of attack. The ΔP is related to pitch and yaw, and is electronically analyzed and displayed on the L/V AOA SPS P_c indicator on MDC-3. The indicator is graduated to 150 percent because of start transients of the SPS. The indicator is monitored for the L/V AOA function from 40 seconds after lift-off until approximately one minute and 40 seconds.

Position of the red line is based on vehicle structural limits and launch vehicle capabilities. A decision for manual abort initiation will be made when the indicator pointer reaches the red line and a master warning is also observed on the FDI.

2.9.2.3 Launch Escape System.

Purpose of the LES (figure 2.9-3) is to provide immediate abort capabilities from the launch pad to the normal time of LES tower jettison. The ABORT SYSTEM - MODE switches 1 and 2 (MDC-16) are in the LES MODE position prior to LES tower jettison, and an abort will be accomplished by utilizing the launch escape system. A manual or

SEQUENTIAL SYSTEMS

SYSTEMS DATA

automatic initiated abort signal will activate a master event sequence controller (MESC). The MESC will initiate C/M-S/M separation, and ignite the launch escape and pitch control motors. Firing of the pitch control motor is automatically inhibited 61 seconds after lift-off by a time-delay relay. The LES motors provide sufficient thrust for the lift and lateral translation of the C/M away from the launch pad, or trajectory of the launch vehicle. Two canard surfaces (figure 2.9-3) are deployed 11 seconds after abort initiation to orient the C/M to a blunt-end-forward attitude. (Refer to Abort Procedures in section 9.)

During a normal mission, the LES tower is jettisoned shortly after second stage booster (S-IVB) engine ignition. LES tower jettison is manually initiated approximately 3 minutes after lift-off by setting the ABORT SYSTEM MODE switches 1 and 2 (MDC-16) to the TWR JETT SPS MODE position. Either switch will enable systems A and B of the redundant circuitry. Both switches should be set at the same time. Any abort, after LES tower jettison, must be accomplished in the SPS mode by utilizing the SPS engine. (Refer to Abort Procedures in section 9.)

A boost protective cover (BPC) completely covers the conical section of the command module. The cover protects the command module and windows from heating during the ascent phase, and soot at launch escape tower jettison in the event of an abort. The cover is attached to and is jettisoned with the LES tower. A removable section allows access to the C/M crew compartment. The cover has one window fabricated of fused silica glass and is located over the forward viewing window.

2.9.2.4 Earth Landing System.

The ELS provides for safe return of the command module and crew following an earth orbital mission, a lunar mission, or mission abort. The ELS consists of two earth landing system controllers (ELSC) and parachutes. The ELS logic circuitry is armed automatically during an abort in the LES mode, and is armed manually with the ELS LOGIC switch on MDC-8 during a SPS abort or normal entry. The ELSC contains baro switches and time-delay relays. After the logic circuitry is armed, the ELSC automatically senses altitude and initiates deployment of the parachutes at the proper time. The time-delay relays control initiation of automatic events after the 24,000 foot baro switch closes. The parachutes (figure 2.9-4) are located in the forward compartment of the C/M, under the apex cover. During a normal entry or descent from an abort initiated above 30,000 feet, the 24,000 foot baro switch closes and completes a circuit to the MESC which jettisons the launch escape tower. The MESC initiates apex cover jettison 0.4 seconds after launch escape tower jettison. Closing of the 24,000 foot baro switch completes a circuit to a 2-second time delay and a 14-second time delay to jettison the drogue parachutes in 2 seconds. The 14-second time delay completes a circuit to the 10,000 foot baro switch.

SEQUENTIAL SYSTEMS

SMZA-03-SC012
APOLLO OPERATIONS HANDBOOK

SYSTEMS DATA

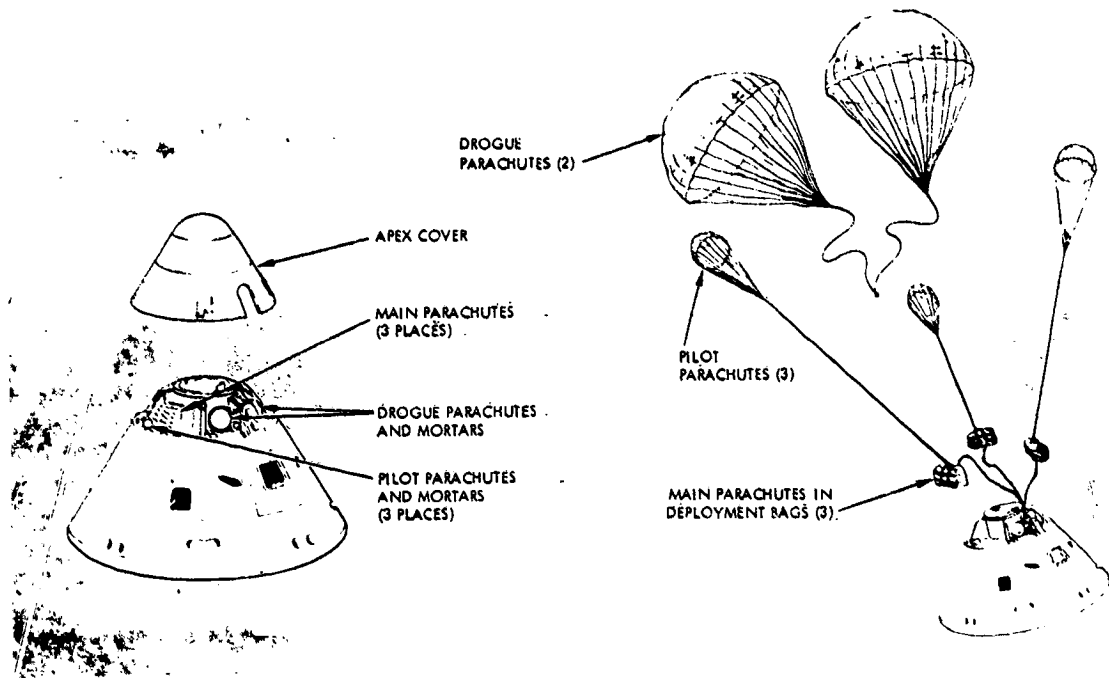

SM-2A-777B

Figure 2.9-4. ELS Parachute Equipment

SEQUENTIAL SYSTEMS

SM2A-03-SC012
APOLLO OPERATIONS HANDBOOK

SYSTEMS DATA

The drogue parachutes are held in a reefed condition for 8 seconds by two reefing lines. Each reefing line has two reefing line cutters. A pyrotechnic time-delay train in each reefing line cutter is ignited at the time of drogue parachute line stretch, causing automatic disreefing after 8 seconds. The drogue parachutes remain attached to the command module until descent to approximately 10,000 feet where the 10,000 feet baro switch closes to initiate drogue parachute disconnect. Simultaneously with drogue parachute disconnect, three pilot parachutes are independently mortar deployed, which removes the main parachute packs from the C/M and extracts the main parachutes from their deployment bags. The main parachutes are reefed for 8 seconds. Disreefing then occurs, and the parachutes fully inflate to lower the C/M safely to landing. Three reefing line cutters are employed on each of the two reefing lines for the main parachutes.

A 27-1/2-degree hang-angle of the C/M is maintained by means of the main parachutes attachment. The hang-angle contributes to the crew tolerance impact by ensuring that impact occurs at the specifically designed C/M structural attenuation point. This attenuation point is on the +Z-axis.

Special note should be made that the apex cover jettison and deployment of the drogue parachutes may be manually initiated at 45,000 feet during a normal entry if the flight characteristics of the command module become unstable. (Refer to operational limitations and restrictions.)

An ELS - AUTO/MAN switch (MDC-16) is provided for the crew to inhibit automatic deployment of the main parachutes during a low-altitude abort initiated prior to 61 seconds after lift-off. The switch is set to the AUTO position prior to launch. In the event of an abort prior to 61 seconds after lift-off, the crew will set the switch to MAN after drogue parachute deployment if the C/M is above an altitude of 3300 feet. Deployment of the main parachutes will be manually initiated by pressing the MAIN DEPLOY switch on MDC-5, when the altimeter pointer reaches the adjustable marker setting (3300 feet) on the altimeter face. This action will preclude the possibility of the command module drifting back on a land area. The ELS switch should be returned to AUTO after the main parachutes are deployed. This will allow a 14-second time delay to time out and permit release of the main parachutes when the MAIN CHUTE RELEASE switch is actuated after touchdown.

SEQ

SEQUENTIAL SYSTEMS

SM2A-03-SC012
APOLLO OPERATIONS HANDBOOK

SYSTEMS DATA

The postlanding recovery aids consist of a sea dye marker, swimmers umbilical, C/M vent fan, C/M uprighting system, HF recovery antenna, and a flashing beacon light. The sea dye marker and swimmers umbilical are deployed automatically when the recovery antenna is deployed. The marker and swimmers umbilical are tethered to the C/M forward compartment deck. The sea dye marker will last approximately 12 hours. The C/M vent fan (part of the ECS) is turned on after landing to vent the C/M to the outside atmosphere. The C/M uprighting system is activated only if the C/M is in a stable inverted attitude. (Refer to Command Module Uprighting System in section 2.)

The flashing beacon light and two VHF antennas located on the forward compartment deck on the C/M are automatically deployed to an upright position after main parachute deployment. The risers of the main parachutes actuate reefing line cutters, which cut retention ties and allows the beacon light and VHF antennas to be extended in 8 seconds. The beacon light has a self-contained power supply capable of operating the light for three 8-hour duty cycles. The flash rate is 15 per minute at an intensity of 1.2 candle-seconds per flash.

The postlanding control switches are located on MDC-25. A recovery pickup cable is provided on the command module for retrieval by recovery forces.

2.9.3 MAJOR COMPONENT/SUBSYSTEM DESCRIPTION.

Each of the sequential systems employ redundant circuits for reliability. Seven batteries are provided in the spacecraft to furnish electrical power for the spacecraft portion of the systems during operation. Entry batteries A, B, and C, and two pyro batteries are located in the command module, and two S/M jettison batteries are located in the service module. Entry batteries A, B, and C are the only batteries that are rechargeable during the mission.

Entry batteries A and B furnish power for the EDS displays and MESC logic circuitry. The pyro batteries furnish power for detonation of pyrotechnic devices during aborts, separation functions, and parachute operation during the normal landing sequence. (See figure 2.9-5 for a C/M battery bus tie-in schematic.) A description of each of the sequential systems is contained in the following paragraphs.

2.9.3.1 Sequential Events Control System.

The SECS consists of two master events sequence controllers (MESC), two earth landing sequence controllers (ELSC), two command

SEQUENTIAL SYSTEMS

SM2A-03-SC012
 APOLLO OPERATIONS HANDBOOK

SYSTEMS DATA

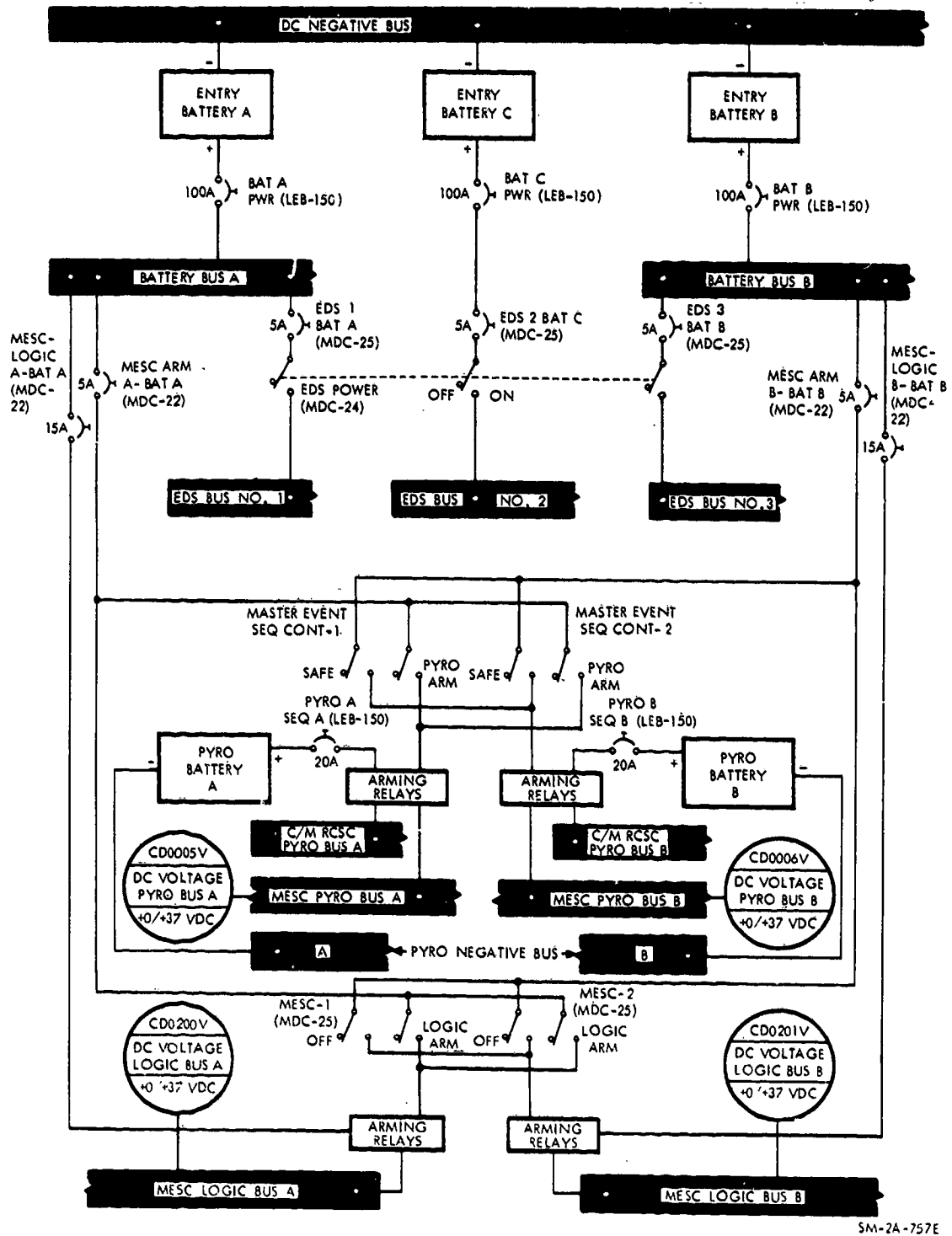

Figure 2.9-5. C/M Battery Bus Tie-In Schematic

SEQUENTIAL SYSTEMS

SM2A-03-SC012
 APOLLO OPERATIONS HANDBOOK

SYSTEMS DATA

module reaction control system controllers (C/M RCSC), and two service module jettison controllers (SMJC). The SMJC is located in the service module. All other controllers are located in the command module. Each controller consists of relays, timers, and other devices to provide automatic and semiautomatic control of the systems.

Many operations in the SECS are accomplished by pyrotechnic devices of various types. Apollo standard initiators (ASI) are used throughout the spacecraft to initiate firing of the pyrotechnic devices. The initiator acts as a primer, in most applications, for the main pyrotechnic device. Pins in the initiators are electrically connected with a one-ohm-resistance wire. When a current of at least 3.5 amperes at 28 volts is applied, the one-ohm-resistance wire ignites a primary explosive. The primary explosive, in turn, ignites a secondary explosive to fire a detonator, igniter, or gas cartridge assembly. The detonator assemblies are used to transfer detonation from the ASI/detonator combination to explosive components to perform a specific function. The other high explosive devices are flexible, linear-shaped charges (FLSC) and mild detonating fuzes (MDF) that are employed during module separation functions. The igniter assemblies are used to ignite the LES motors. The gas cartridges are used to actuate the apex cover thruster assemblies, canard thrusters, SLA thrusters, circuit interrupters, and parachute deployment mortars. A control relay maintains a shunt across each pyrotechnic device prior to firing and simultaneously removes the shunt upon receiving a firing command. The Apollo standard initiator (ASI) acts as a pressure cartridge for RCS pyrotechnic valves.

The major pyrotechnic functions performed by the SECS are listed below.

Function and Pyro Device	Normal Actuating Control	Backup Control
Spacecraft LEM Adapter (SLA) separation	Automatic signal from MESC during SPS abort and manual control from ADAPT SEP switch	Command pilots translation control (left arm rest)
a. Umbilical disconnect		
b. Adapter separation (explosive train)		
c. Panel thrusters (8)		
Apex cover jettison	Automatic signal from MESC	APEX COVER JETT switch (MDC-5)
a. Thruster cartridges		
b. Apex cover pilot parachute mortar		

SEQUENTIAL SYSTEMS

SM2A-03-SC012
 APOLLO OPERATIONS HANDBOOK

SYSTEMS DATA

Function and Pyro Device	Normal Actuating Control	Backup Control
RCS oxidizer dump a. He isolation valves b. He interconnect valve c. Oxidizer isolation valve d. Gas chromatograph	Automatic signal from RCSC during a LES abort initiated prior to 61 seconds after lift-off.	None for fast dump.
Oxidizer and fuel burnoff a. He interconnect valves b. Fuel interconnect valve c. Oxidizer interconnect valve	Manual actuation of the C/M PROP JETT-DUMP switch (MDC-8)	
RCS purge a. Oxidizer bypass valves b. Fuel bypass valves	C/M PROP JETT - PURGE switch (MDC-8)	C/M RCS - He DUMP/OFF switch (MDC-26), and also opposite commands from rotational controllers one and two for roll and yaw. One controller also commands minus pitch.
Drogue parachute mortars	Automatic signal from ELSC	DROGUE DEPLOY switch (MDC-5)
Pilot parachute mortars	Automatic signal from ELSC	MAIN DEPLOY switch (MDC-5)
Main parachute release mechanism	Manual actuation of MAIN CHUTE RELEASE switch (MDC-16)	None
C/M-S/M separation a. Tension-tie cutting charges	Automatic signal from MESC during a LES abort or C/M-S/M SEP switches 1 and 2 during normal mission	Command pilots translation control (left arm rest) for LES abort and C/M-S/M SEP switches 1 and 2 if translation control does not work.

SEQUENTIAL SYSTEMS

SEC

SM2A-03-SC012
 APOLLO OPERATIONS HANDBOOK

SYSTEMS DATA

Function and Pyro Device	Normal Actuating Control	Backup Control
b. C/M-RCS pressurizing valves c. Circuit interrupters d. C/M-S/M umbilical guillotine e. LE and Pc motors igniter cartridges LE tower (TWR) jettison	Automatic signal from MESC or manual control from ABORT SYSTEM - MODE switches 1 and 2	ABORT SYSTEM - MODE switches 1 and 2 (MDC-16)
a. TWR to C/M attaching nuts (explosive) b. TWR jettison motor igniter cartridges		
Postlanding antenna deploy	Manual actuation of POSTLANDING - DEPLOY switches 1 and 2 (MDC-25)	

2.9.3.1.1 Master Events Sequence Controllers (MESC).

The MESC (figure 2.9-6) provides the logic and timing to initiate and terminate events associated with the ascent and abort modes. Controller A is in system A and controller B is in system B of the redundant systems. Crossover circuitry between controllers A and B ensures correct outputs for detonating pyrotechnic devices even if one redundant circuit is inoperative. The logic circuitry is armed with the two MESC-LOGIC ARM switches 1 and 2 on MDC-25. The pyro circuitry is armed with the two MASTER EVENT SEQ CONT-PYRO ARM switches 1 and 2 on MDC-24. Backup controls are provided for most of the events controlled by the MESC.

2.9.3.1.2 Earth Landing System Controllers (ELSC).

The ELSC (figure 2.9-7) provide automatic and manual control of drogue parachute deployment, drogue parachute release, and pilot parachute deployment. Two redundant controllers are provided for dual redundancy. Relays are energized in the ELSC and a pyro continuity verification box (PCVB) to control pyrotechnic devices and perform the events. The PCVB provides an access for checkout of pyro circuitry, and contains relays that work in conjunction with the ELSC. The ELSC contains baro switches that inhibit automatic operation of the ELS above

SEQUENTIAL SYSTEMS

SM2A-03-SC012
APOLLO OPERATIONS HANDBOOK

SYSTEMS DATA

the baro switch setting. Other events are controlled by time-delay relays after the baro switches close. Refer to functional description of the ELS.

2.9.3.1.3 Command Module Reaction Control System Controllers (C/M RCSC).

The C/M RCSC (figure 2.9-8) provide automatic and manual control of events that occur in the reaction control system. Two redundant controllers are provided for dual redundancy. During an abort initiated prior to 61 seconds after lift-off, the C/M RCS oxidizer and helium are automatically dumped. When the abort signal is received, the following pyro valves are fired by initiators to pressurize and dump the RCS oxidizer:

- a. Two helium isolation valves
- b. Helium interconnect valve
- c. Oxidizer interconnect valve
- d. Two oxidizer overboard dump valves

The oxidizer overboard dump valves route the oxidizer to a blow-out plug in the aft heat shield of the C/M. Pressure buildup shears a pin which releases the blowout plug and dumps the oxidizer overboard.

The helium pressure is dumped into the aft compartment 18 seconds after abort initiation when the following pyro valves are fired by initiators:

- a. Helium interconnect valve
- b. Two oxidizer tanks bypass valves
- c. Helium overboard dump valve

The three entry batteries are automatically connected to d-c main buses A and B during an LES abort or normal C/M-S/M separation, RCS control is transferred (S/M to C/M). (See figure 2.9-9 for RCS control schematic.) The controllers inhibit automatic oxidizer dump, helium dump, and LES pitch control motor firing automatically at 61 seconds after lift-off. RCS propellant burn and purge must be manually selected.

The pyro buses are armed when the MASTER EVENT SEQ CONT - PYRO ARM switches 1 and 2 are set to the PYRO ARM position. Backup controls are provided for most of the functions performed by the RCSC.

2.9.3.1.4 Service Module Jettison Controllers (SMJC).

The SMJC (figure 2.9-10) program the operation to impart a desired motion to the service module after C/M-S/M separation. The S/M reaction control system will be controlled by the SMJC and command continuous firing of the -X jets. It is possible that the resultant -X thrusting will be offset from the S/M X-axis; therefore, the S/M RCS + roll jets are activated for a 5.5-second interval, 2 seconds after separation. This ensures that a major component of the jettison thrusting will be in a direction that was parallel to the CSM (-X) axis at

SEQUENTIAL SYSTEMS

SM2A-03-SC012
APOLLO OPERATIONS HANDBOOK

SYSTEMS DATA

severance. The dual controllers are powered by dual separation batteries located in the S/M. The batteries are not rechargeable during the mission.

2.9.3.1.5 C/M-S/M Separation Mechanism.

The C/M-S/M separation mechanism (figure 2.9-11) consists of electrical circuit interrupters, shear compression pads, tension ties, linear-shaped charges, and a dual-blade guillotine (umbilical severance device). Redundant systems (A and B) in the MESG provide dual redundant commands to fire dual initiators and charges to ensure sudden complete tension and umbilical severance with adequate reliability. Prior to umbilical severance, sensitive circuits in the umbilical are deadfaced by circuit interrupters. The shear compression pads are designed for interference-free separation after the tension ties are severed. A separation signal is sent to dual redundant service module jettison controllers which control the S/M after it separates from the C/M.

2.9.3.1.6 Spacecraft LEM Adapter (SLA) Separation Mechanism.

A command for CSM-SLA separation is automatically sent to the MESG when a SPS abort is manually initiated. An ADAPT SEP switch on MDC-5 may be used as a backup and for normal CSM-SLA separation during a normal mission. Separation of the adapter into four panels (figure 2.9-12) is accomplished by an explosive train. The explosive train consists of 28 charge holders, 2 initiators and shields, 8 panel thrusters, 8 initiator pressure cartridges, and an umbilical separation system. Redundant detonator assemblies fire dual lines of mild detonating fuse (MDF) installed between the adapter panels, top and bottom, and between each panel. Either line will sever the splice plates between the four panels and around both ends. Crossover boosters are used in the charge holder joints to ensure that both lines are firing simultaneously for complete reliability. The detonating lines are continuous lead sheaths surrounding an explosive core which is virgin RDX, class G. The mild detonating fuse separates the adapter panels and fires cartridges for the panel thrusters which open the four panels. Simultaneously with this operation, umbilical disconnect takes place. Four spring-loaded reels hold the panels in a 45-degree open position. The panels are stopped in the open position by eight attenuators that have honeycomb cores.

2.9.3.2 Emergency Detection System.

The EDS consists of sensors, logic circuitry and signal conditioners located in the launch vehicle, displays and controls located in the C/M, and Q-ball which is located on the forward tip of the LES tower above the canard. The displays and controls consist of L/V rates, L/V guidance, abort, and engine lights, along with an angle-of-attack

SEQUENTIAL SYSTEMS

SM2A-03-SC012
 APOLLO OPERATIONS HANDBOOK

SYSTEMS DATA

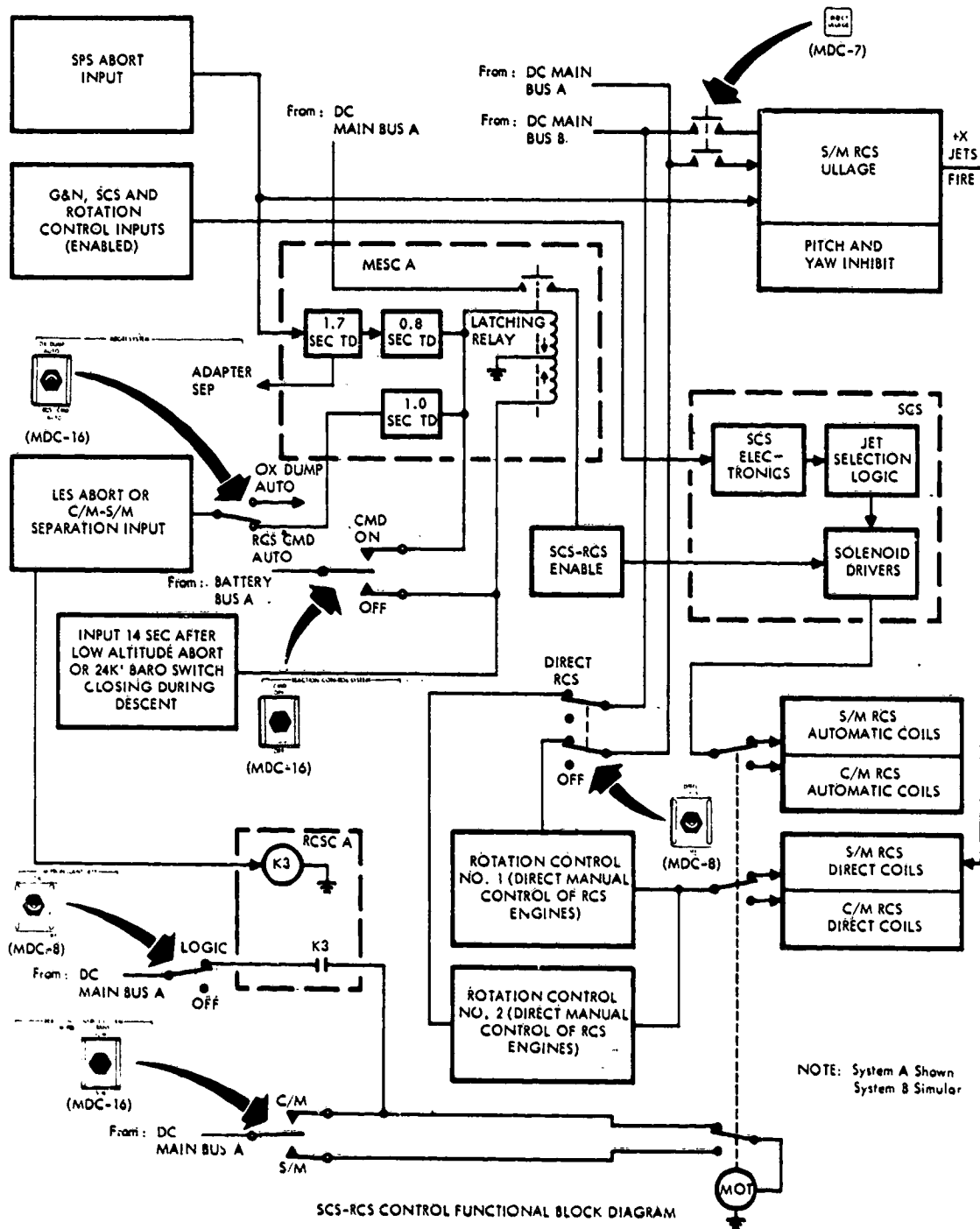

Figure 2.9-9. SCS-RCS Functional Block Diagram

SEQUENTIAL SYSTEMS

SM2A-03-SC012
 APOLLO OPERATIONS HANDBOOK

SYSTEMS DATA

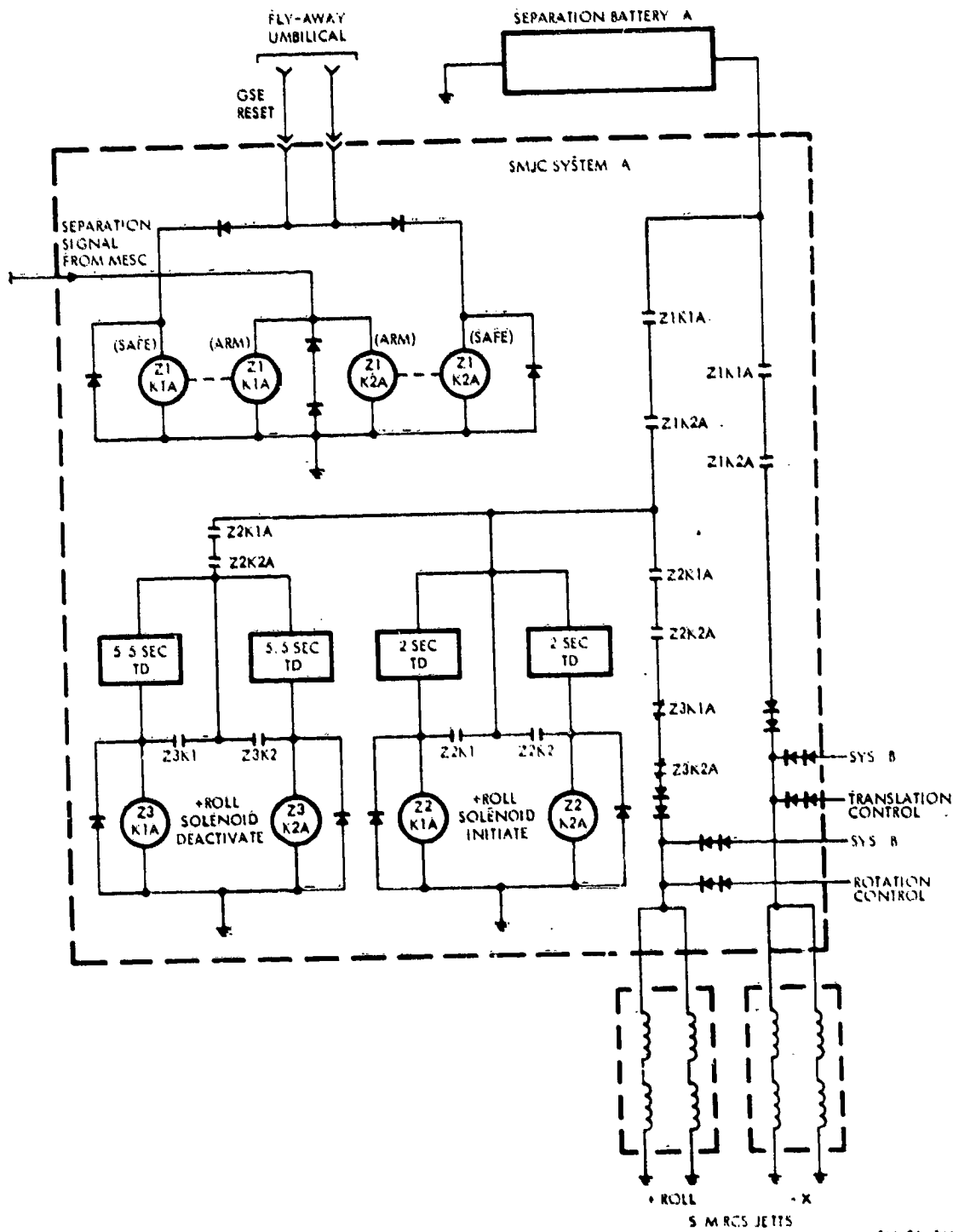
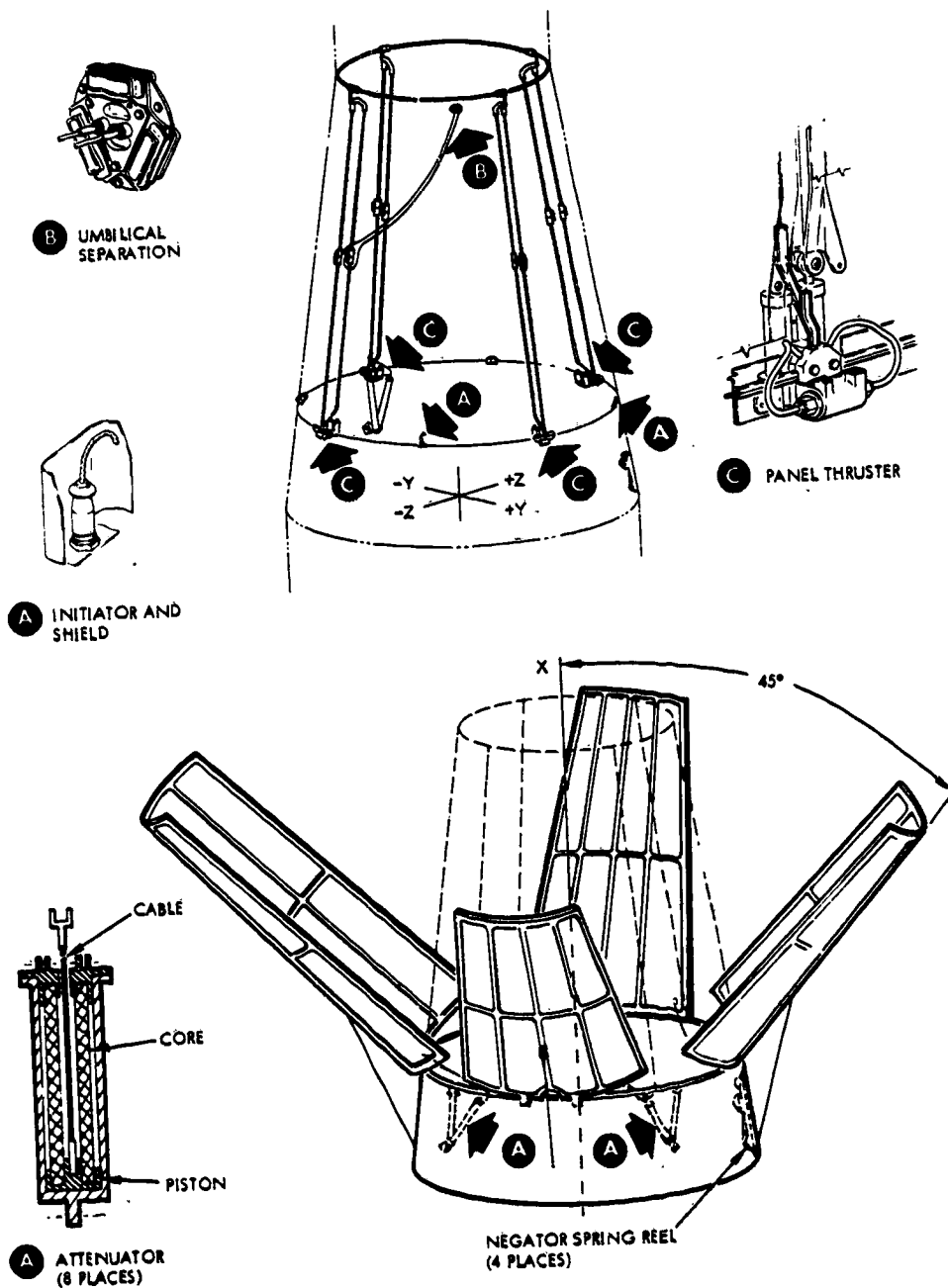

Figure 2.9-10. Service Module Jettison Controller Schematic

SEQUENTIAL SYSTEMS

SM2A-03-SC012
 APOLLO OPERATIONS HANDBOOK

SYSTEMS DATA



SM-2A-895 A

Figure 2.9-12. Adapter Separation Mechanism

SEQUENTIAL SYSTEMS

SM2A-03-SC012
APOLLO OPERATIONS HANDBOOK

SYSTEMS DATA

indicator and control switches. The L/V portion of the EDS and the Q-ball are powered by eight L/V batteries. The displays are powered by two entry batteries A and B.

2.9.3.3 Launch Escape System.

The LES consists of two major assemblies (figure 2.9-3) that are installed on top of the command module prior to launch. The first structure is a four-legged, welded tubular titanium tower. The tower is attached to the command module with four frangible nuts on studs. Two detonator assemblies are installed in each nut to break it when LES tower jettison is commanded. The second structure is cylindrical in shape topped by the Q-ball, and houses the launch escape, tower jettison, and pitch control motors. A canard subsystem is installed near the forward end below the Q-ball.

2.9.3.3.1 LES Motors.

Each of the three motors in the LES (figure 2.9-3) are fired by two igniter assemblies. The three motors are the launch escape motor, tower jettison motor, and pitch control motor. The pitch control motor works in conjunction with the launch escape motor during a LES abort initiated prior to 61 seconds after lift-off. The pitch control motor has a fixed zero-degree, single-exhaust nozzle and is mounted below the ballast enclosure in a horizontal position. The motor produces approximately 2500 pounds of thrust for about 0.5 second to force the nose of the LES tower in the -Z direction. Firing of the pitch control motor is inhibited 61 seconds after lift-off by a signal from the C/M RCSC. The launch escape motor has four nozzles that have a centerline cant angle of 35 degrees. The resultant thrust vector deflection is obtained by offsetting the nozzle throat diameters and producing a thrust vector in the -Z direction. Thrust output is approximately 150,000 pounds which starts dropping in approximately 4 seconds. Lateral translation of the escape vehicle is aided by the thrust vector alignment offset during an LES abort. The tower jettison motor has two nozzles in which the thrust vector alignment is offset approximately 4 degrees to produce a thrust component in the +Z direction. Thrust output is approximately 33,000 pounds.

2.9.3.3.2 Canard Subsystem.

The canard subsystem (figure 2.9-3) consists of two deployable surfaces faired into the outer skin of the LES below the Q-ball interface. Each surface is mounted on two hinges and is operated open by a pyrotechnic thruster with redundant gas cartridges. The surfaces are approximately 47 inches long, clam-shell shaped, and constructed of double-skin ribbed inonel. The canard surfaces are automatically opened during a LES abort and aerodynamic forces acting on the surfaces control a turnaround maneuver of the C/M. (Refer to Abort Procedures in section 9.)

SEQUENTIAL SYSTEMS

SM2A-03-SC012
APOLLO OPERATIONS HANDBOOK

SYSTEMS DATA

2.9.3.4 Earth Landing Subsystem.

The ELS consists of the parachute subsystem (figure 2.9-4), two earth landing sequence controllers (figure 2.9-7), and the apex cover jettison mechanism.

The parachute subsystem is comprised of two fist-ribbon-type nylon drogue parachutes, 13.7 feet in diameter; three ring-slot-type nylon pilot parachutes, 7.2 feet in diameter; three ring-sail-type nylon main parachutes, 83.5 feet in diameter; deployment bags; bridles; suspension lines; mortars; and the necessary hardware for attachment to the C/M. The parachute subsystem is housed in the forward compartment under the apex cover of the C/M.

The earth landing sequence controllers are located in the right equipment bay of the C/M and controls automatic operation of the ELS. Crossover circuitry between the controllers ensures correct output signals. Backup emergency switches are provided on MDC-5 for apex cover jettison and parachute deployment. The apex cover is jettisoned by four gas-operated thrusters. Two gas-type cartridges are employed for redundancy and operate two thrusters each. Either pair of thrusters will jettison the apex cover. A pilot parachute and mortar are installed in the forward end of the apex cover. The mortar is fired at exactly the same time as the apex cover thrusters to deploy the parachute. The parachute will pull the apex cover from the negative pressure area following the C/M.

2.9.4 PERFORMANCE AND DESIGN DATA.

Entry descent velocities, altitude, and time are contained in the following tabulated data. The figures are based on a command module recovery weight of 11,000 pounds and a standard day barometric pressure.

The tabulated data states the automatic events that normally occur in the ELS during descent. Under certain entry conditions, the apex cover may be manually jettisoned, and the drogue parachutes manually deployed at 45,000 feet. Refer to operational limitations and restrictions that follow the tabulated data.

SEQUENTIAL SYSTEMS

SM2A-03-SC012
APOLLO OPERATIONS HANDBOOK

SYSTEMS DATA

Occurrence	Altitude	Time on Parachutes	Descent Velocity
TWO DROGUE PARACHUTES			
24,000 foot baro switch closes	24,900 to 21,500 feet		
Apex cover jettison	24,000 foot baro switch closure + 0.4 seconds		425 ft/sec
Drogue parachutes (2) deploy	24,000 foot baro switch closure + 2.0 seconds		410 ft/sec
10,000 foot baro switch closes	10,950 to 9,100 feet		
Drogue parachutes (2) release and main parachutes deploy	10,000 foot baro switch closure	45 to 46 seconds	225 ft/sec
Main parachutes open (reefed) after two drogue parachutes release			235 ft/sec
Main parachutes disreef	8400 ±500 feet	8 seconds after line stretch	110 ft/sec
ONE DROGUE PARACHUTE			
Drogue parachute (1) releases and main chutes deploy	10,000 foot baro switch closure	40 seconds	275 ft/sec
Main parachutes open (reefed) after one drogue parachute releases			290 ft/sec
Main parachutes disreef	8200 ±500 feet	8 seconds after line stretch	120 ft/sec
Touchdown (3 main parachutes)		5 minutes	28 ft/sec
Touchdown (2 main parachutes)		4.2 minutes	33.5 ft/sec

SEQUENTIAL SYSTEMS

SYSTEMS DATA

2.9.4.1 Power Requirements.

The SECS requires power only during the launch and ascent phase, for CSM-SLA separation in orbit, for C/M-S/M separation during the pre-entry phase, and during the parachute descent phase. Most all events performed by the SECS occur instantaneously, and not on a continuous duty cycle. In accordance with the Mission Modular Data Book (SID 66-1177), dated 1 September 1966, there are no power requirements for the SECS.

2.9.5 OPERATIONAL LIMITATIONS AND RESTRICTIONS.

Under certain entry conditions, the spacecraft may become unstable. Because of the erratic aerodynamic damping coefficients, wind gusts, and shears, the astronaut may not be able to damp the oscillations with single RCS. If this should occur, the apex cover and drogue parachutes may be manually deployed at 45,000 feet. This will stabilize and keep the C/M in a heat shield forward descending attitude. Figure 2.9-13 portrays the drogue development design envelope. The following precautions should be observed.

- Manual initiation of apex cover jettison and drogue parachute deployment should never be accomplished above 45,000 feet during entry.
- The C/M RCS must be turned off prior to apex cover jettison.
- The LES tower and apex cover should never be manually jettisoned above the automatic mode of 24,000 feet during LES aborts.

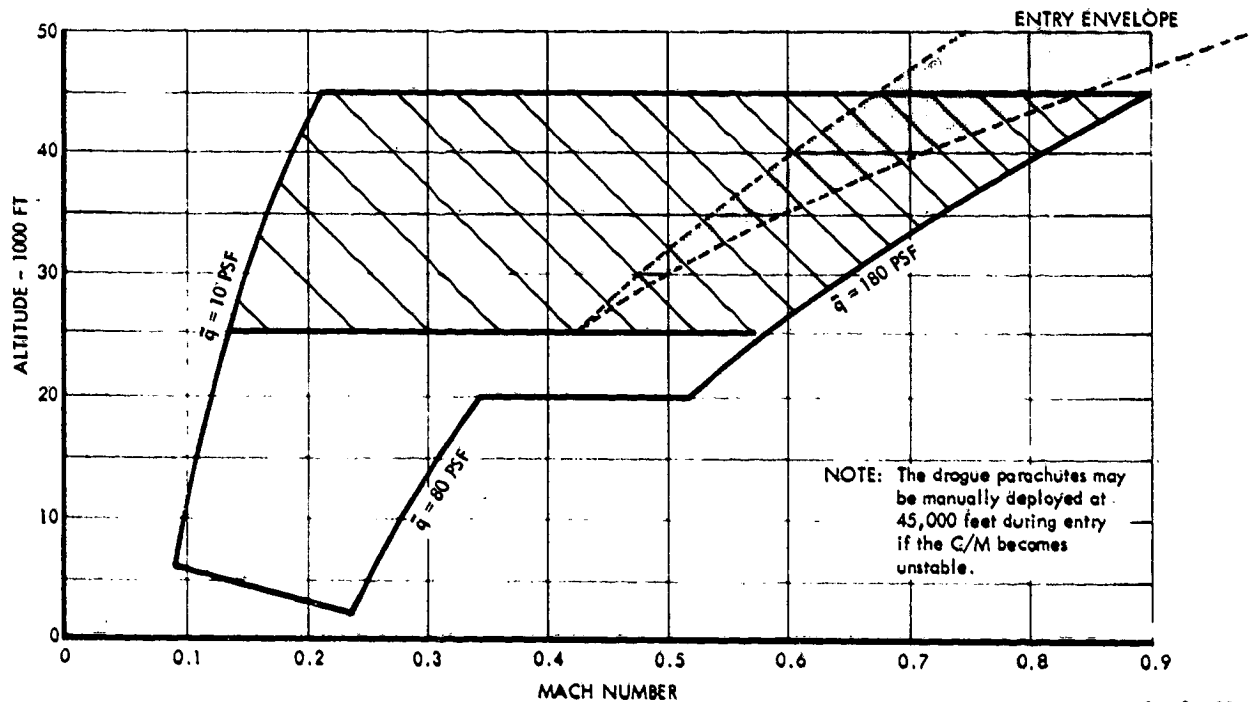

Figure 2.9-13. Drogue Parachute Deployment Design Envelope

SEQUENTIAL SYSTEMS

SM2A-03-SC012
APOLLO OPERATIONS HANDBOOK

SYSTEMS DATA

2.9.6 TELEMETRY MEASUREMENTS.

The following is a complete list of all sequential systems telemetry data that is monitored by flight controllers and ground support personnel. The last column contains the name and type of S/C crew display. The display utilizes the same pickoff or signal sources as telemetry, unless a separate measurement number is included in the display column.

An asterisk (*) by the measurement number denotes information which is not available for recording or telemetry transmission during PCM low bit rate operation.

Measurement Number	Description	Sensor Range	Crew Display
CD 0136 X	EDS abort logic out B	Event	None
CD 0140 X	Direct ullage on A	Event	None
CD 0141 X	Direct ullage on B	Event	None
CD 0170 X	RCS activate signal A	Event	None
CD 0171 X	RCS activate signal B	Event	None
CD 0173 X	CM-RCS pressurize signal A	Event	None
CD 0174 X	CM-RCS pressurize signal B	Event	None
*CD 0200 V	DC voltage logic bus A	+0. +37 vdc	None
*CD 0201 V	DC voltage logic bus B	+0./+37 vdc	None
CD 0230 X	Forward heat shield jettison A	Event	None
CD 0231 X	Forward heat shield jettison B	Event	None
CD 0315 X	EDS enable A	Event	None
CD 0316 X	EDS enable B	Event	None
CD 1006 X	LES motor fire initiate A	Event	None
CD 1007 X	LES motor fire initiate B	Event	None
CE 0001 X	Drogue deploy relay close A	Event	None
CE 0002 X	Drogue deploy relay close B	Event	None
CE 0003 X	Main parachute deploy-drogue release relay A	Event	None

SEQUENTIAL SYSTEMS

SM2A-03-SC012
APOLLO OPERATIONS HANDBOOK

SYSTEMS DATA

Measurement Number	Description	Sensor Range	Crew Display
CE 0004 X	Main parachute deploy-drogue release relay B	Event	None
CE 0007 X	Baroswitch lock-in relay close A	Event	None
CE 0008 X	Baroswitch lock-in relay close B	Event	None
*CE 0035 P	Barometric pressure static reference	+0/+15 psia	Indicator
CE 0321 X	Main chute disconnect relay A	Event	None
CE 0322 X	Main chute disconnect relay B	Event	None
*LS 0001 V	Q-ball vector sum output	+0/+5 vdc	Indicator
BS 0016 X	Launch vehicle guidance fail A	Event	L/V GUID light
BS 0020 X	Launch vehicle rate excessive A	Event	L/V RATE light
BS 0030 X	Engine No. 1 out A	Event	ENGINES 1 light
BS 0032 X	Engine No. 2 out A	Event	ENGINES 2 light
BS 0034 X	Engine No. 3 out A	Event	ENGINES 3 light
BS 0036 X	Engine No. 4 out A	Event	ENGINES 4 light
BS 0038 X	Engine No. 5 out A	Event	ENGINES 5 light
BS 0040 X	Engine No. 6 out A	Event	ENGINES 6 light
BS 0042 X	Engine No. 7 out A	Event	ENGINES 7 light
BS 0044 X	Engine No. 8 out A	Event	ENGINES 8 light
BS 0061 X	Lift-off signal B	Event	LIFT OFF light

SEQUENTIAL SYSTEMS

Mission _____ Basic Date 12 Nov 1966 Change Date _____ Page 2.9-37

SM2A-03-SC012
 APOLLO OPERATIONS HANDBOOK.

SYSTEMS DATA

Measurement Number	Description	Sensor Range	Crew Display
CS 0050 X	FDS abort request A	Event	ABORT light
CS 0050 X	Tower physical separation monitor A	Event	None
CS 0050 X	Tower physical separation monitor B	Event	None
CS 0050 X	CM-SM physical separation monitor A	Event	None
CS 0050 X	CM-SM physical separation monitor B	Event	None
CS 0050 X	SM/adaptor physical separation monitor A	Event	None
CS 0050 X	SM/adaptor physical separation monitor B	Event	None

SEQUENTIAL SYSTEMS

SYSTEMS DATA

SECTION 2

SUBSECTION 2.10

CAUTION AND WARNING SYSTEM (C&WS)

2.10.1 INTRODUCTION.

The C&WS monitors critical parameters of most S/C systems in the C/M and S/M. When a malfunction or out-of-tolerance condition occurs in any of these systems, the crew is immediately alerted in order that corrective action may be taken.

2.10.2 FUNCTIONAL DESCRIPTION.

Upon receipt of malfunction or out-of-tolerance signals, the C&WS simultaneously identifies the abnormal condition and alerts the crew to its existence. Each signal will activate an appropriate systems status indicator and a master alarm circuit. The master alarm circuit visually and aurally attracts the crew's attention by alarm indicators on the MDC and an alarm tone in the headsets. Crew acknowledgement of an abnormal condition consists of resetting the master alarm circuit, but retaining the particular systems status malfunction indication. The capability exists for the crew to select several modes of observing systems status and master alarm indicators, and of monitoring C/M or S/M systems.

2.10.3 MAJOR COMPONENT/SUBSYSTEM DESCRIPTION.

The C&WS consists of one major component, the detection unit. It is located behind MDC-13 and, therefore, is neither visible nor accessible to the crew during the mission. The balance of the system is made up of visual indicators, aural alerting and associated circuits, and those switches required to control the various system functions. Visual indicators include the five upper-most electromechanical event devices on MDC-18, as well as all systems status and master alarm lights.

The detection unit circuits consist of comparators, logic, level detectors, lamp drivers, and a master alarm and tone generator. Also incorporated are two redundant power supplies that furnish regulated +12 and -12 d-c voltages for the electronics. Inputs to the detection unit consist of both analog and event-type signals.

The analog signals, totaling 51 inputs, are in the 0- to 5-volt d-c range. Alarm limits for these signals trigger voltage comparators, which, in turn, activate logic and lamp-driver circuits. This causes activation of the master alarm circuit and tone generator, illumination of application systems status lights on MDC-10 and -11, and/or activation of applicable electromechanical event indicators on MDC-18. A total of 25 event inputs are fed to the C&WS detection unit. These signals originate from solid state and mechanical switch closures in malfunction sensing devices. Of this number, 19 signals will directly illuminate applicable system status lights, and through logic circuitry, activate the master alarm circuit (and tone generator). Two other event signals directly illuminate the system

CAUTION AND WARNING SYSTEM

APOLLO OPERATIONS HANDBOOK

SYSTEMS DATA

status lights, but require level detectors to activate the master alarm circuit. Each of the four remaining event signals is set to an OR gate, which is also fed by two analog signals. The resulting output will activate lamp drivers and the master alarm circuit. One other event signal, originating within the detection unit directly, illuminates the CAUT/WARN FAIL light, but activates only the MASTER ALARM lights of the MASTER ALARM circuit.

The master alarm circuit alerts crewmembers whenever abnormal conditions are detected. This is accomplished visually by the illumination of remote MASTER ALARM switch-lights on MDC-3 and -18, and the MASTER ALARM light on LEB-103. An audio alarm tone, sent to the three headsets, aurally alerts the crew, regardless of whether the telecomm system is activated. The output signal of the tone generator is a square wave that is alternately 750 cps and 2000 cps, changing at a frequency of 2.5 cps. Although the tone is audible above the conversation level, it does not render normal conversation indistinct or garbled. When the crew has noted the abnormal condition, the three alarm lights and the tone generator are deactivated and reset by pressing either MASTER ALARM switch-light, both of which incorporate a push-switch. This action leaves the systems status lights illuminated, and resets the master alarm circuit for alerting the crew to the next abnormal condition. The individual system status lights will remain illuminated until the malfunction or out-of-tolerance condition is corrected.

The C&WS power supplies include sensing and switching circuitry that assure unit self-protection should high-input current, or high- or low-output voltage occur. Any of these conditions will cause the illumination of the master alarm lights and the CAUT-WARN FAIL systems status light. The tone generator, however, will not be activated due to requiring the 12-volt output from the malfunctioned power supply for its operation. The crew must then manually select the redundant power supply to return the C&WS to operation. In so doing, the CAUT/WARN FAIL status light is extinguished, but the master alarm circuit is activated, thus requiring it to be reset.

Incorporated into the C&WS is the capability to test the lamps of systems status and master alarm lights. Position 1 of the LAMP TEST switch (MDC-23) controls the illumination of status lights on MDC-10 and the MASTER ALARM switch-lights on MDC-3 and MDC-18. Position 2 tests only the status lights on MDC-11. The remaining MASTER ALARM light is on LEB-103, and is tested along with the nine G&N condition lights on that panel by pressing the CHECK CONDITION LAMPS push-switch on LEB-105. Although these nine lights are not part of the C&WS, all but three of them (PGNS, ZERO ENCODER, and IMU DISPLAY) are duplicated on MDC-10.

Switches on the MDC enable the crew to select C&WS operational modes. The position of the MODE switch (MDC-11) establishes the S/C systems to be monitored. Before separation and entry, systems in both the C/M and S/M are monitored for malfunction or out-of-tolerance conditions. After CSM separation, however, only those systems in the C/M are monitored. Repositioning the switch also prevents S/M systems status lights and event indicators from remaining activated after separation.

The C/W switch (MDC-13) permits three modes of status and alarm light illumination. For most of the mission the switch is set to the NORMAL position to give normal C&WS light operation; that is, upon receipt of abnormal condition signals, all systems status lights and master alarm

CAUTION AND WARNING SYSTEM

SM2A-03-SC012
APOLLÓ OPERATIONS HANDBOOK

SYSTEMS DATA

lights are capable of illumination. During the ascent phase the switch is set to the BOOST position, so that although all other C&WS lights operate normally, the MASTER ALARM switch-light on MDC-3 will not illuminate. This prevents possible confusion on MDC-3 between the red MASTER ALARM light and the adjacent red ABORT light. The ACK switch position is selected when the crew desires to adapt their eyes to orbital darkness, or if a continuously illuminated systems status light is undesirable. While in this mode, incoming signals will activate only the master alarm lights and the tone generator. To determine the abnormal condition, the crew must press either MASTER ALARM switch-light. This illuminates the applicable systems status light, and deactivates and resets the master alarm circuit. The systems status light will remain illuminated only as long as the switch-light is pressed. However, it may be recalled as long as the abnormal condition exists by again pressing either switch-light.

2.10.3.1. Electrical Power Distribution.

The C&WS only receives power from 28-volt d-c sources. (See figure 2.10-1.) Before CSM separation, the power source is from the fuel cells in the S/M, and following separation, from batteries located in the C/M.

2.10.4. PERFORMANCE AND DESIGN DATA.

2.10.4.1. C&WS Power Consumption Data.

Total power consumed by the C&WS amounts to 7.5 watts, which is the maximum quiescent power for detection unit operation. Very small amounts of power are also required to illuminate several lamps whenever the C&WS is activated by malfunction input signals. These small amounts, however, are not considered in the overall C&WS power requirements.

2.10.5. OPERATIONAL LIMITATIONS AND RESTRICTIONS.

2.10.5.1. C&WS General Data.

With the C/W switch in the BOOST position during ascent, the MASTER ALARM switch-light on MDC-3 will not illuminate should a malfunction occur. The master alarm circuit reset capability of the light is also disabled during this time. This requires the MASTER ALARM switch-light on MDC-18 to be used exclusively for monitoring and resetting functions.

Several peculiarities should be noted in regard to the CAUT. WARN-POWER switch. Whenever this switch is moved from, or through, the OFF position to either power supply position, the master alarm circuit is activated, which then requires it be reset. Also, switching from one power supply to another (when there is not power supply failure) will cause the CAUT/WARN FAIL status light to illuminate at the OFF position, and then be extinguished when the other power supply position is reached.

CAUTION AND WARNING SYSTEM

SM2A-03-SC012
 APOLLO OPERATIONS HANDBOOK

SYSTEMS DATA

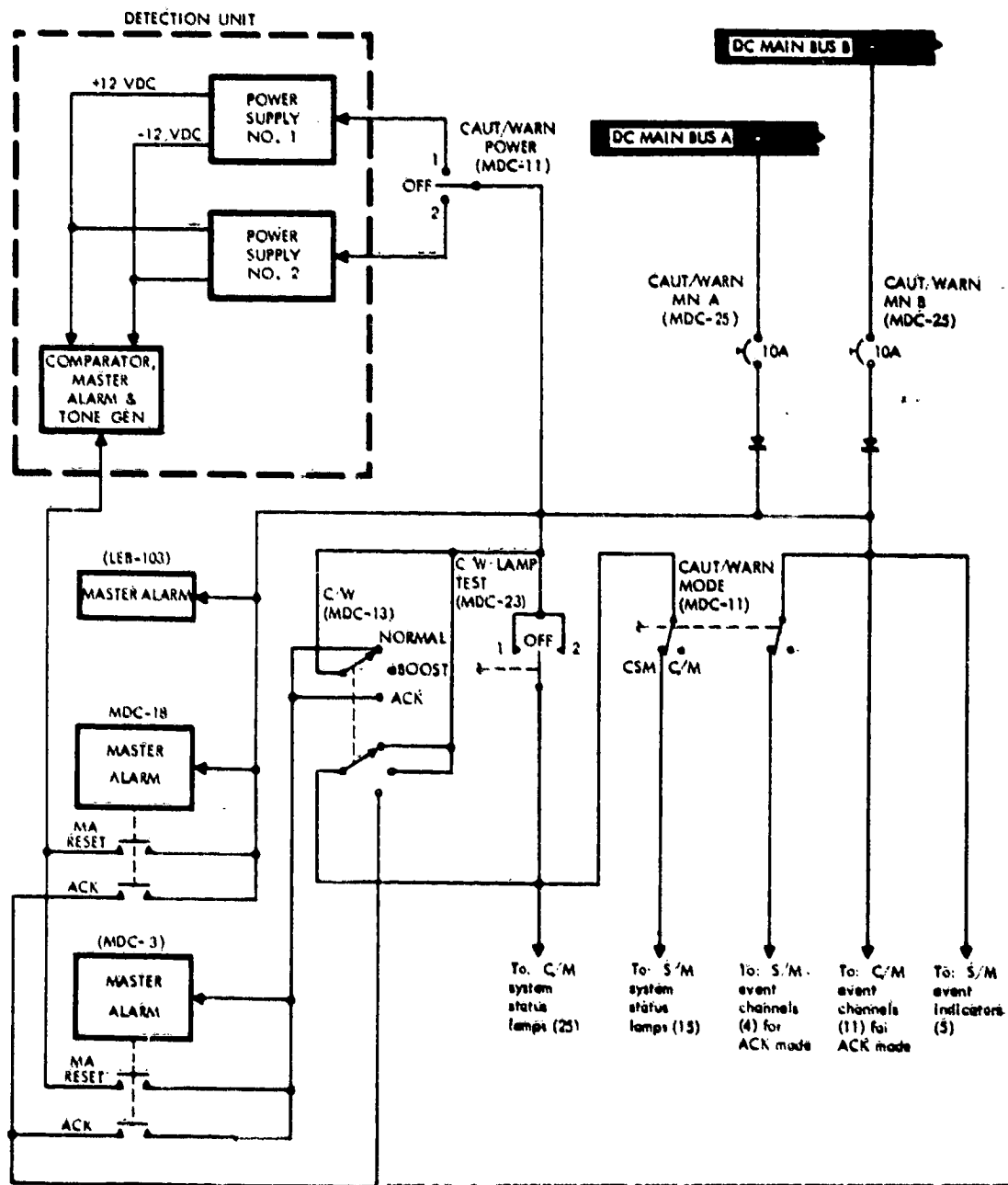

SM-2A-873C

Figure 2.10-1. CRWS Power Distribution Diagram

CAUTION AND WARNING SYSTEM

SYSTEMS DATA

Should the redundant power supply also fail, the C&WS is degraded to the following extent. Rendered inoperative is the complete master alarm circuit, as well as those status lights that illuminate as the result of analog-type input signals. This leaves only those status lights operative that require event-type input signals. Included are the following S/M and C/M lights: CDU FAIL, G&N ACCEL FAIL, IMU FAIL, G&N ERROR, IMU TEMP, GMBL LOCK, AGAP TEMP, SPS ROUGH ECO, H₂P ACCUM FAIL, PITCH GMBL DR FAIL, YAW GMBL DR FAIL, SPS PU SNSR FAIL, O₂ FLOW HI, F/C BUS DISCONNECT, AC 1 BUS FAIL, AC BUS 1 OVERLOAD, AC 2 BUS FAIL, AC BUS 2 OVERLOAD, MN BUS A UNDERVOLT, MN BUS B UNDERVOLT, and CAUT/WARN FAIL.

The CAUT/WARN-MODE switch must be in the CSM position in order to conduct a lamp test of those status lights associated with S/M systems. The status lights of C/M systems may be tested with the MODE switch in either position. Circuit design also permits a complete lamp test to be conducted with the C/W switch in the ACK position.

Normally, each abnormal condition signal will activate the C&WS master alarm circuit and tone generator, and illuminate an applicable systems status light. The one exception to this concept is when the C&WS power supply fails. The visual indicators will function, but not the tone generator portion of the master alarm circuit. This is due to the tone generator requiring the +12 and -12 d-c voltage output of the failed power supply for its operation.

The MASTER ALARM light on LEB-103 is part of the master alarm circuit of the C&WS. As such, it is illuminated whenever the master alarm circuit is activated by an incoming abnormal condition signal. A lamp check of this light, however, is not accomplished by the C&WS. Instead, the light is checked by pressing the CHECK CONDITION LAMPS push-switch on LEB-105. The primary function of this switch is to check the lamps of the nine G&N-condition lights on LEB-103, none of which are part of the C&WS.

2.10.5.2 System Status Light Data.

The following list provides the lamp trigger values and associated information for all system status lights on MPC 10 and 11.



CAUTION AND WARNING SYSTEM

SM2A-03-SC012
APOLLO OPERATIONS HANDBOOK

SYSTEMS DATA

Status Light	Lamp Trigger Value	TLM Code No.	Other Indication	S/C Mode	Remarks
CDU FAIL	1. Loss (-50%) 2% 6KV supply 2. Loss (-50%) motor excitation 3. ICDU error >1.2 mV for 5 seconds 4. MCDU error >1.2 mV for 5 seconds 5. OCDU error >1.2 mV for 5 seconds	CG5002X	PGNS light illuminated (LEB-103).	C/M	Light enabled in fine align mode only.
IMU FAIL	1. Loss (-50%) 3200 cps 2. Loss (-50%) 800 cps wheel power 3. IG servo air >2.9 mV for 2 seconds 4. MG servo air >2.9 mV for 2 seconds 5. OG servo air >2.9 mV for 2 seconds	CG5001X	PGNS light illuminated (LEB-103).	C/M	Inhibited (by AGC program) in coarse align mode.
IMU TEMP	1. IRIG temp <132°F 2. IRIG temp >138°F 3. PIPA temp <132°F 4. PIPA temp >138°F	CG5006X	None	C/M	IRIG temp (135°F) is internal and not end cap temp.
AGAP TEMP	1. Any BMAG <160°F 2. Any BMAG >171°F	CH2030V	None	C/M	
G&N ACCEL FAIL	1. X PIPA error >27 mV for 5 seconds 2. Y PIPA error >27 mV for 5 seconds 3. Z PIPA error >27 mV for 5 seconds —	CG5000X	PGNS light illuminated (LEB-103).	C/M	
G&N ERROR	1. Down TLM word rate too high or low 2. Up TLM bit rate too high 3. Up-link data in error	CG5005X	DSKY-TM FAIL (LEB-106) and PGNS lights (LEB-103) illuminated.	C/M	
GMBL LOCK	MG angle > 60°	CG5003X	FDAI attitude ball red zone under new axis indicator.	C/M	
H ₂ PRESS	1. Tank 1 > 220 psia 2. Tank 1 > 270 psia 3. Tank 2 > 220 psia 4. Tank 2 > 270 psia	SF0039P S10040P	TANK PRESSURE H ₂ -1 indicator TANK PRESSURE H ₂ -1 indicator	S/M	
C/M RCS A	1. Fuel tk H ₂ press < 265 psia 2. Fuel tk H ₂ press > 325 psia 3. Ox tk H ₂ press < 265 psia 4. Ox tk H ₂ press > 325 psia	CR0005P CR0011P	C/M RCS PRESS-F indicator C/M RCS PRESS-OX indicator	C/M	Light functional only when CAUT/WARN-MODE switch in C/W
C/M RCS B	1. Fuel tk H ₂ press < 265 psia 2. Fuel tk H ₂ press > 325 psia 3. Ox tk H ₂ press < 265 psia 4. Ox tk H ₂ press > 325 psia	CR0006P CR0012P	C/M RCS PRESS-F indicator C/M RCS PRESS-OX indicator	C/M	Light functional only when CAUT/WARN-MODE switch in C/M
AGC PWR FAIL	1. Loss of 125 vdc supply 2. Loss of 113 vdc supply 3. Loss of 134 vdc supply	CG5010X	PGNS light illuminated (LEB-103).	C/M	

CAUTION AND WARNING SYSTEM

SM2A-03-SC012
APOLLO OPERATIONS HANDBOOK

SYSTEMS DATA

Status Light	Lamp Trigger Value	TLM Code No.	Other Indication	S/C Mode	Remarks				
O ₂ PRESS	1. Tank 1 <800 psia 2. Tank 1 >950 psia 3. Tank 2 <800 psia 4. Tank 2 >950 psia	SF0037P	TANK PRESSURE-O ₂ -1 indicator	S/M					
		SF0038P	TANK PRESSURE-O ₂ -2 indicator						
S M RCS A	1. Pkg temp <63°F 2. Pkg temp >175°F 3. Reg He press <155 psia 4. Reg He press >215 psia	SR5065T	S/M RCS TEMP-PKG indicator	S/M					
		SR5729P	S/M RCS PRESS-MANF indicator						
S M RCS B	1. Pkg temp <63°F 2. Pkg temp >175°F 3. Reg He press <155 psia 4. Reg He press >215 psia	SR5066T	S/M RCS TEMP-PKG indicator	S/M					
		SR5776P	S/M RCS PRESS-MANF indicator						
S M RCS C	1. Pkg temp <63°F 2. Pkg temp >175°F 3. Reg He press <155 psia 4. Reg He press >215 psia	SR5067T	S/M RCS TEMP-PKG indicator	S/M					
		SR5817P	S/M RCS PRESS-MANF indicator						
S M RCS D	1. Pkg temp <63°F 2. Pkg temp >175°F 3. Reg He press <155 psia 4. Reg He press >215 psia	SR5068T	S/M RCS TEMP-PKG indicator	S/M					
		SR5830P	S/M RCS PRESS-MANF indicator						
SPS ROUGH ECO	1. 180G's for 70 m seconds 2. 360G's for 30 m seconds	None	Engine cuts off.	S/M	G-levels are peak-to-peak.				
H ₂ O ACCUM FAIL	Three O ₂ bubbles (min) in outlet water line	None	None	C/M					
F/C BUS DISCONNECT	1. Fwd current at 75 amps for 15 min. or at 112 amps for 25 to 300 seconds 2. Reverse current at 4 amps for 10 sec. or 20 amps for 1 sec.	SC2120X SC2121X SC2122X SC2125X SC2126X SC2127X	MN BUS A event indicator (3) MN BUS B event indicator (3)	S/M					
F/C I	1. H ₂ flow <0.018 lb/hr 2. H ₂ flow >0.16 lb/hr 3. O ₂ flow <0.14 lb/hr 4. O ₂ flow >1.27 lb/hr 5. At pH factor of 9 6. Skin temp <360°F 7. Skin temp >500°F 8. Cond exh <155°F 9. Cond exh >175°F 10. Rad out temperature below -30°F 11. H ₂ reg press >75 psia 12. O ₂ reg press >75 psia 13. N ₂ reg press >70 psia	SC2139R	FUEL CELL-FLOW-H ₂ indicator	S/M	Event indicators pH, HI, F/C RAD TEMP, LO, H ₂ PRESS, O ₂ PRESS, and N ₂ PRESS are activated at lamp trigger values.				
		SC2142R	FUEL CELL-FLOW-O ₂ indicator						
		SC2160X	pH HI event ind						
		SC2084T	MODULE TEMP-SKIN indicator						
		SC2081T	MODULE TEMP-COND EXH indicator						
		SC2087T	F/C RAD TEMP LOW event indicator						
		SC2069P	REG OUT PRESS HI -H ₂ event ind						
		SC2066P	REG OUT PRESS HI -O ₂ event ind						
		SC2060P	REG OUT PRESS HI -N ₂ event ind						
		CC0175T	None						
		CF0020T	GLY EVAP-OUTLET TEMP indicator						
		INA I TEMP HI	At 241°F			CC0175T	None	C/M	
		GLYCOL TEMP LOW	At -30°F			CF0020T	GLY EVAP-OUTLET TEMP indicator	C/M	

CAUTION AND WARNING SYSTEM

SM2A-03-SC012
APOLLO OPERATIONS HANDBOOK

SYSTEMS DATA

Status Light	Lamp Trigger Value	TLM Code No.	Other Indication	S/C Mode	Remarks
SPS PRESS	1. Fuel tk lte press <160 psia 2. Fuel tk lte press >200 psia 3. Ox tk lte press <160 psia 4. Ox tk lte press >200 psia	SP0006P SP0003P	PRESSURE-FUEL indicator PRESSURE-OX indicator	S/M	
F/C 2	1. H ₂ flow <0.018 lb/hr 2. H ₂ flow >0.16 lb/hr 3. O ₂ flow <0.14 lb/hr 4. O ₂ flow >1.27 lb/hr 5. At pH factor of 9 6. Skin temp <350°F 7. Skin temp >500°F 8. Cond exh <155°F 9. Cond exh >175°F 10. Rad out temp below -30°F 11. H ₂ reg press >75 psia 12. O ₂ reg press >75 psia 13. N ₂ reg press >70 psia	SC2140R SC2143R SC2161X SC2085T SC2082T SC2088T SC2070P SC2067P SC2061P	FUEL-CELL-FLOW-H ₂ indicator FUEL CELL-FLOW-O ₂ indicator pH HI event ind MODULE TEMP-SKIN indicator MODULE TEMP-COND EXH indicator F/C RAD TEMP LOW event indicator REG OUT PRESS HI-H ₂ event indicator REG OUT PRESS HI-O ₂ event indicator REG OUT PRESS HI-N ₂ event indicator	S/M	Event indicator pH HI, F/C RAD TEMP LO, H ₂ PRESS, O ₂ PRESS, and N ₂ PRESS are activated at lamp trigger values.
INV 2 TEMP HI	At 240°F	CC0176T	None	C/M	
PITCH GMBL DR FAIL	1. Under 6 amps 2. Over 40 amps	SP1000X	None	S/M	Overcurrent conditions dependent upon time and temp.
SPS WALL TEMP HI	At 378°F	SP0020T	None	S/M	
F/C 3	1. H ₂ flow <0.018 lb/hr 2. H ₂ flow >0.16 lb/hr 3. O ₂ flow <0.14 lb/hr 4. O ₂ flow >1.27 lb/hr 5. At pH factor of 9 6. Skin temp <360°F 7. Skin temp >500°F 8. Cond exh <155°F 9. Cond exh >175°F 10. Rad out temp below -30°F 11. H ₂ reg press >75 psia 12. O ₂ reg press >75 psia 13. N ₂ reg press >70 psia	SC2141R SC2144R SC2162X SC2086T SC2083T SC2089T SC2071P SC2068P SC2062P	FUEL CELL-FLOW-H ₂ indicator FUEL CELL-FLOW-O ₂ indicator pH HI event ind MODULE TEMP-SKIN indicator MODULE TEMP-COND EXH indicator F/C RAD TEMP LOW event indicator REG OUT PRESS HI-H ₂ event indicator REG OUT PRESS HI-O ₂ event indicator REG OUT PRESS HI-N ₂ event indicator	S/M	Event indicators pH HI, F/C RAD TEMP LO, H ₂ PRESS, O ₂ PRESS, and N ₂ PRESS are activated at lamp trigger values.
INV 1 TEMP HI	At 241°F	CC0177T	None	C/M	
YAW GMBL DR FAIL	1. Under 6 amps 2. Over 40 amps	SP1001X	None	S/M	Overcurrent condition dependent upon time and temp.
SPS PI SNSR FAIL	1. F/ON ratio unbalance over 300 lbs. or 90° of critical unbalance. 2. Primary and aux systems 1 to 4 dis. repaired.	None	UNBALANCE indicator (for over 300 lbs only)	S/M	Light functional only during SPS firing.

CAUTION AND WARNING SYSTEM

SM2A-03-SC012
 APOLLO OPERATIONS HANDBOOK

SYSTEMS DATA

Status Light	Lamp Trigger Value	TLM Code No.	Other indication	S/C Mode	Remarks
MIN BUS A UNDERVOLT	At 26.25±0.1 vdc	CG0206V	DC VOLTS meter	C/M	
MIN BUS B UNDERVOLT	At 26.25±0.1 vdc	CG0207V	DC VOLTS meter	C/M	
CO ₂ PP III	At 7.6 mm Hg	CF0005P	PART PRESS CO ₂ indicator	C/M	
AC BUS 1 FAIL	1. At 95±3 vdc 2. At 130±2 vdc	CG0200V CG0201V CG0202V	AC VOLTS meter	C/M	
AC BUS 2 FAIL	1. At 95±3 vdc 2. At 130±2 vdc	CC0203V CC0204V CC0205V	AC VOLTS meter	C/M	
CAUTION WARN FAIL	1. At +11.7 vdc or -11.7 vdc 2. At +13.9 vdc or -13.9 vdc	None	MASTER ALARM lights (3)	C/M	Alarm tone inoperative.
O ₂ FLOW III	At 1.0 lb/hr	None	FLOW O ₂ indicator	C/M	
AC BUS 1 OVERLOAD	1. 30 at 9 amp/0 for 15±5 sec 2. 10 at 11 amp for 5±1 sec	None	AC VOLTS meter	C/M	Overload disconnects inverter from bus.
AC BUS 2 OVERLOAD	1. 30 at 9 amp/0 for 15±5 sec 2. 10 at 11 amp for 5±1 sec	None	AC VOLTS meter	C/M	Overload disconnects inverter from bus.

CAUTION AND WARNING SYSTEM

Mission _____ Basic Date 11 Nov 1968 Changed Date _____ Page 2.10

SM2A-03-SC012
APOLLO OPERATIONS HANDBOOK

SYSTEMS DATA

2.10.6 TELEMETRY MEASUREMENTS

The following is a complete list of all C&WS telemetry data that is monitored by flight controllers and ground support personnel. The last column contains the name and type of S/C crew display. The display utilizes the same pickoff or signal source as telemetry, unless a separate measurement number is included in the display column.

Measurement Number	Description	Sensor Range	Crew Display
CS0150X	Master caution-warning on	Off/on event	MASTER ALARM lights

CAUTION AND WARNING SYSTEM

Mission _____ Basic Date 12 Nov 1966 Change Date _____ Page 2.10-10

SYSTEMS DATA

SECTION 2

SUBSECTION 2.11

MISCELLANEOUS SYSTEMS DATA

2.11.1 INTRODUCTION.

Miscellaneous systems data pertains to items that were not covered in a previous system. These items consist of clocks, timers, accelerometers (G-meter), interior lighting, etc.

2.11.2 CLOCKS.

Two clocks and two clock-like event timers, all mechanical, are provided for the crew in the command module. The 400-hour clock (MDC-12), used in monitoring mission elapsed time, is illuminated by floodlights. The GMT 24-hour clock and two 10-hour event timers are located on panel 306 in the LH forward equipment bay and lighted by integral bulbs controlled by the CLOCKS-BRT/OFF/DIM switch on LEB 100. For further information, refer to section 4.

2.11.3 DIGITAL EVENT TIMERS.

The digital event timers provide the crew with a means of monitoring and timing events. One event timer is located on MDC-5 the other is located on MDC-11. The event timers start automatically when lift-off occurs, and the timer located on MDC-5 will be reset if an abort is automatically or manually initiated. For further information, refer to section 3.

2.11.4 ACCELEROMETER (G-METER).

The accelerometer or G-meter (MDC-2), provides the crew with a visual indication of spacecraft positive and negative G-loads. This meter is illuminated by floodlights controlled by the LH area control panel (MDC-26). For detailed information on the accelerometer (G-meter), refer to section 4.

2.11.5 COMMAND MODULE INTERIOR LIGHTING.

The interior lighting provides light for the main display console and LEB panels in the command module.

MISCELLANEOUS SYSTEMS DATA

SM2A-03-SC012
APOLLO OPERATIONS HANDBOOK

SYSTEMS DATA

2.11.5.1 Functional Description.

The interior lighting equipment consists of eight floodlight fixture assemblies and three control panels. Each fixture assembly contains two fluorescent lamps (one primary and one secondary) and a converter. The interior lighting is powered by 28 volts dc from main buses A and B for redundancy (figure 2.11-1). This assures a power source for lights in all areas in the event that either bus fails. The converter in each floodlight fixture converts 28 volts dc to a-c power to operate the fluorescent lamps. The floodlights are used to light three areas: the main display console (left and right areas) and the LEB area. Control panel (MDC-26) is located on the left and control panel (MDC-23) is located on the right of the main display console (figure 2.11-2). The third control panel is located in the lower equipment bay area on LEB-100. The floodlight fixtures are located around the interior of the command module. (See figure 2.11-2.)

Each control panel has a primary and secondary control for the floodlights in its respective area. The primary control is a rheostat that controls brightness of the primary floodlights. The secondary control is an ON-OFF switch for the secondary floodlights and is turned to ON when additional brightness is desired. The floodlight circuit breakers are on MDC-25. The operational use, or brightness level of the floodlights depends on two factors: the g-level and the task being performed. The floodlights should be turned up bright during ascent and entry. The floodlights will be adjusted as required while in earth orbit. The FDAI (MDC-4) is lighted by integral bulbs which are controlled by the FDAI LTG switch on MDC-25 and FDAI BRIGHTNESS rheostat on MDC-2. A switch is provided on the LEB floodlight control panel to control lighting for the clocks on LHFEB-306.

2.11.6 COMMAND MODULE UPRIGHTING SYSTEM.

The C/M uprighting system is manually controlled and operated after the C/M has assumed a stable inverted floating attitude. The system consists of three inflatable air bags, two relays, three solenoid control valves, two air compressors, control switches, and air lines. The inflatable bags are located in the C/M forward compartment and the air compressors are located in the aft compartment. The control switches and circuit breakers are located in the crew compartment. Switches 1 and 2 are powered by the postlanding bus switch 3 and the compressors are powered by battery buses A and B. (See figure 2.11-3.)

2.11.6.1 Functional Description.

POSTLANDING - FLOAT BAG switch 1 controls inflation of the air bag on +Y axis, switch 2 controls inflation of the air bag on the -Y axis, and switch 3 controls inflation of the air bag on the +Z axis of the C/M. (See figure 2.11-3.) Each bag is 43 inches in diameter and has a capacity of approximately 24 cubic feet when inflated. If the C/M becomes inverted

MISCELLANEOUS SYSTEMS DATA

Mission _____ Basic Date 12 Nov 1966 Change Date _____ Page 2.11-2

SYSTEMS DATA

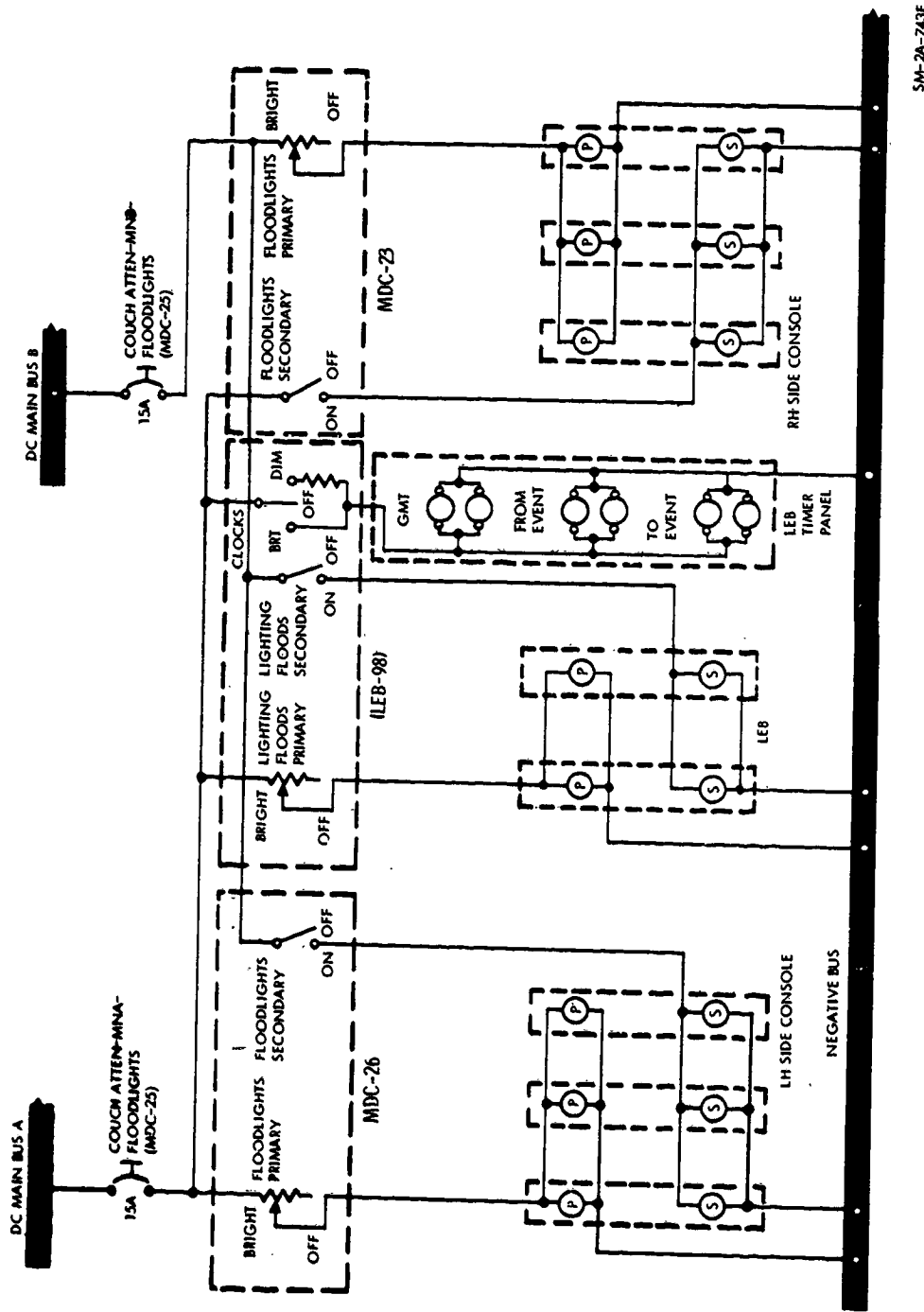

SM-2A-743F

Figure 2.11-1. C/M Interior Lighting Schematic

MISCELLANEOUS SYSTEMS DATA



SYSTEMS DATA

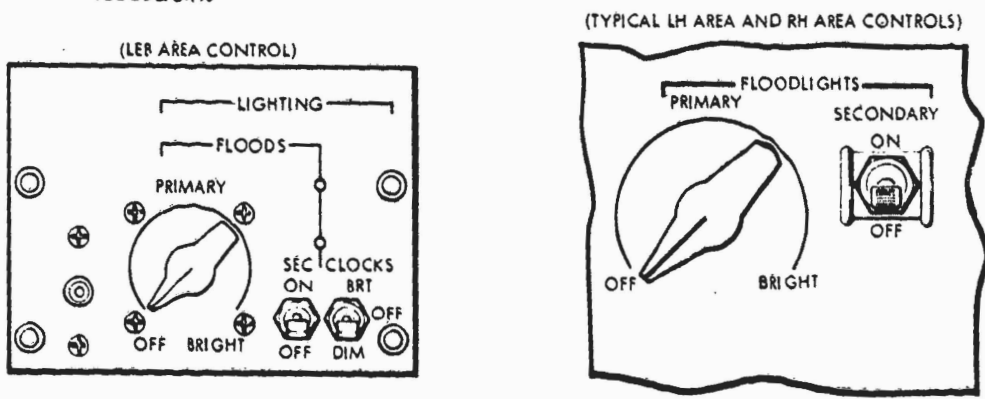
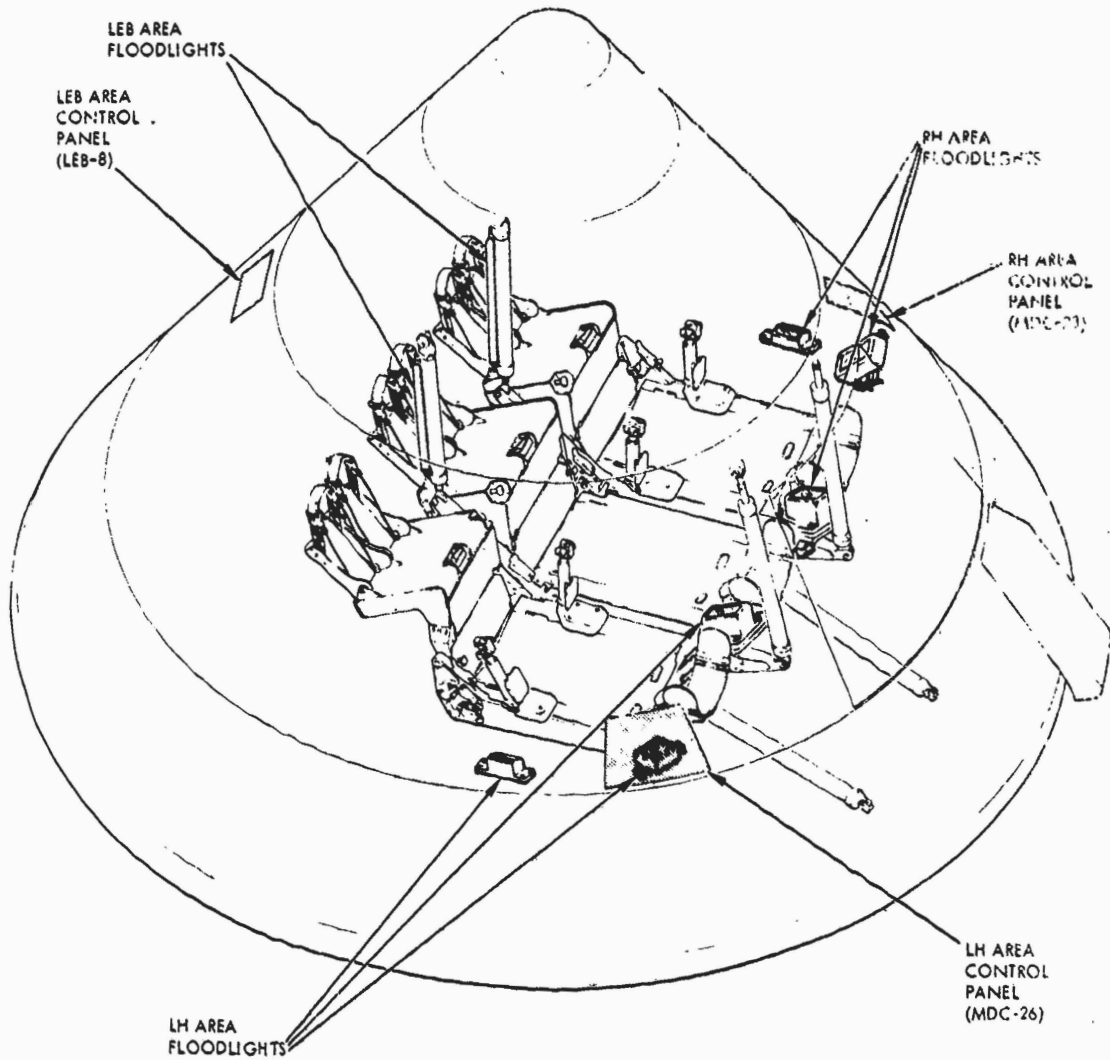

SM-2A-830A

Figure 2.11-2. C/M Interior Lighting Configuration

MISCELLANEOUS SYSTEMS DATA

SYSTEMS DATA

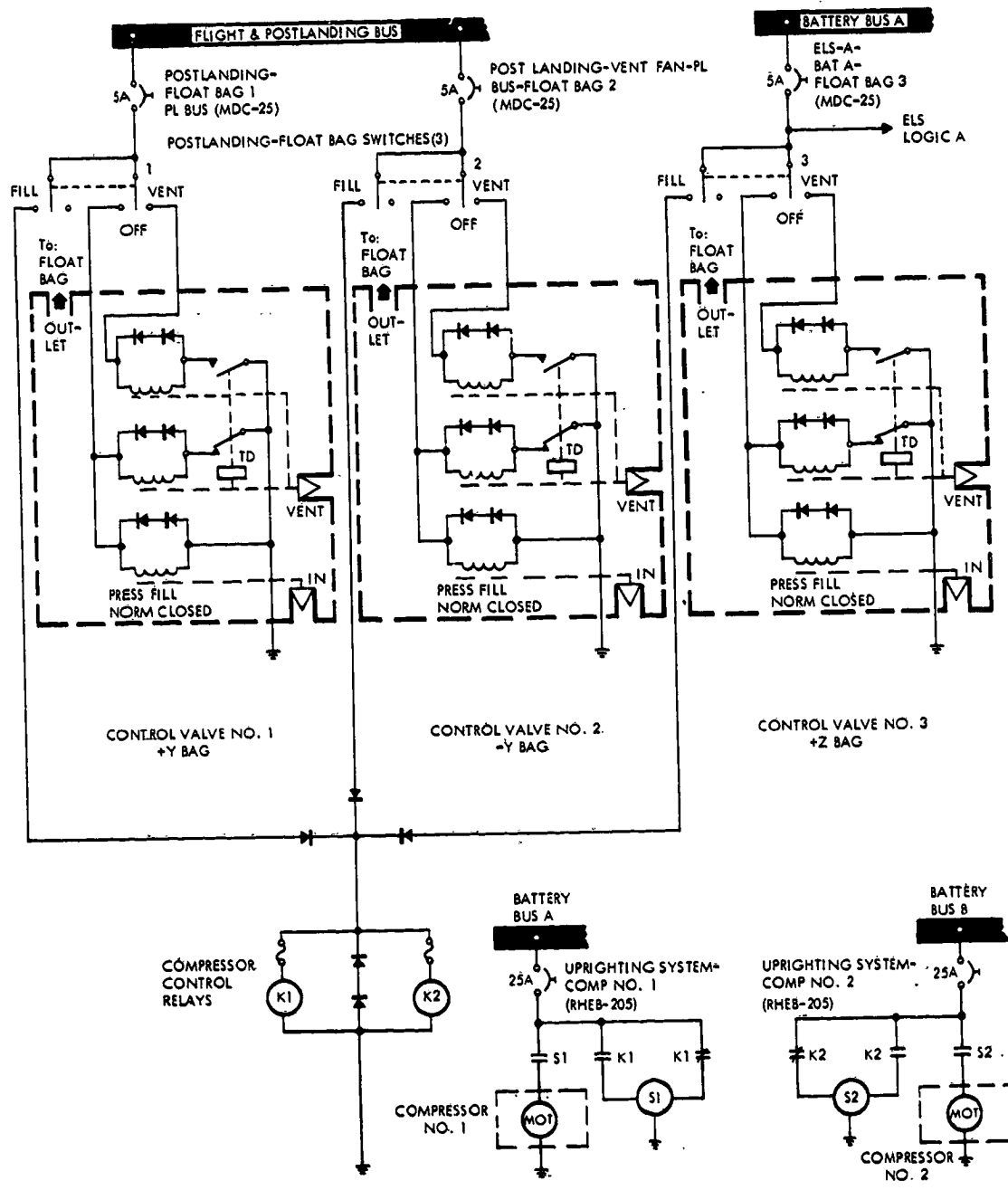

SM-2A-882C

Figure 2.11-3. C/M Uprighting System Electrical Schematic

MISCELLANEOUS SYSTEMS DATA

SM2A-03-SC012
APOLLÓ OPERATIONS HANDBOOK

SYSTEMS DATA

after landing, the crewmember at station 1 initiates filling of the three bags by setting the POSTLANDING - FLOAT BAG switches 1, 2, and 3 to FILL. When the C/M is uprighted, the three FLOAT BAG switches will be set to OFF. A 4.25 ± 0.25 psi relief valve is located in the inlet of each bag. Backup relief valves set at 13.5 psi are located in the outlet of each compressor.

MISCELLANEOUS SYSTEMS DATA

Mission _____ Basic Date 17 Nov 1966 Change Date _____ Page 3.11.5

CONTROLS AND DISPLAYS

SECTION 3
CONTROLS AND DISPLAYS

INTRODUCTION.

This section identifies each control and display in the command module and lists panel location, item nomenclature, positions and related functions, power source, telemetry measurement number, and associated explanatory data. Controls and displays are presented in a tabulated list in numerical order by panel number. Panel numbers are those appearing on the main display console drawing and the lower equipment bay drawing in figure 3-1. (The command module itself does not incorporate numbers on the panels.) The following is a detailed explanation of the columnar data presented in the tabulated list.

Location	Gives the location of a particular control or display by panel number or other descriptive information such as: "LH couch armrest, etc."
Name and Position	Gives the exact nomenclature of a particular control or display and the control positions, as placarded on the panel. In the absence of a placard, a functional name is assigned and the positions are described physically ("up," "down," etc).
Function	Describes the function of each control in each position.
Circuit Breaker	Gives the name and location of the circuit breaker(s) controlling the electrical power to each control & display.
Power Source	Identifies and gives the rating of the immediate bus or source supplying power to a particular control or display.
Telemetry Code No. and Identity	Gives the measurement numbers for telemetry signals which are used to monitor the performance of components, systems, and subsystems, the status of consumable items, and the proper sequencing of critical

CONTROLS AND DISPLAYS

CONTROLS AND DISPLAYS

operations during all phases of the spacecraft mission. This information is monitored at MSFN stations for spacecraft management from the ground by use of voice or command links. Measurement numbers are entered only for displayed measurements. Those for undisplayed measurements are included in the telemetry measurements table for the appropriate system in section 2 of this handbook.

The number consists of seven characters: two letters followed by four numbers and one letter. An example is as follows:

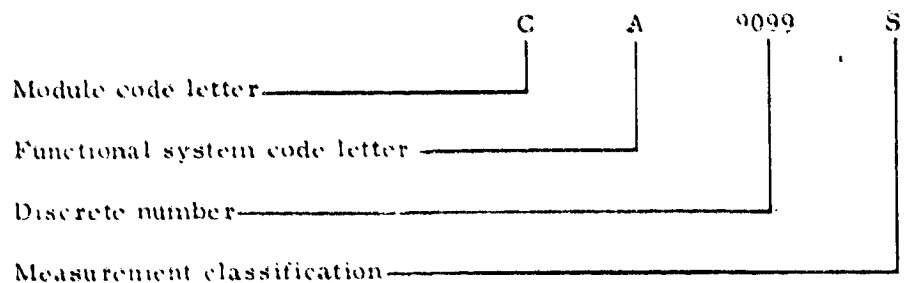

a. The first letter designates the module in which the measurement originates. Module code letters are as follows:

- | | |
|------------------|-----------------------|
| A Adapter | L Launch escape tower |
| B Booster | S Service module |
| C Command module | |

b. The second letter denotes the system in which the measurement originates. Functional system code letters are as follows:

- | | |
|-----------------------------|--|
| A Structures | J Life systems |
| C Electrical power | K Flight technology |
| D Launch escape | P Propulsion |
| E Earth landing | R Reaction control |
| F Environmental control | S Crew safety |
| G Guidance and navigation | T Telecommunications and instrumentation |
| H Stabilization and control | |

c. Characters three through six are numerals comprising a number which is assigned to a particular measurement point. These numbers are listed sequentially or are grouped for clarity within each system.

CONTROLS AND DISPLAYS

SM2A-03-SC012
APOLLO OPERATIONS HANDBOOK

CONTROLS AND DISPLAYS

d. The seventh letter denotes measurement classification. Classification code letters are as follows:

A Acceleration	N Camera
B Phase	P Pressure
C Current	Q Quantity
D Vibration	R Rate
E Power	S Strain
F Frequency	T Temperature
G Force	V Voltage
H Position	W Time
J Biomedical	X Discrete event
K Radiation	Y Acoustical
L Velocity	Z pH - acidity
M Mass	

Remarks Contains additional data and explanatory remarks.

3.1 CONTROLS/DISPLAYS LOCATOR INDEX.

To aid in finding data within this section, a locator index precedes the tabulated list. The index is sub-divided into spacecraft systems. Under each system is listed, in alphabetical order, all controls and displays associated with the particular system with cross reference to the panel on which the control or display is located. Where items, such as circuit breakers, are associated with more than one system, such items are repeated under each applicable system. Each panel number is preceded by an abbreviated descriptor to aid in quickly determining the general location of each item, as follows:

MDC	main display console (panels 1 thru 26)
LEB	lower equipment bay (panels 100 thru 107, 120, 150)
LHEB	left hand equipment bay (panels 307 thru 317 and 319)
LHFEb	left hand forward equipment bay (panels 300 thru 306 and 318)
RHEB	right hand equipment bay (panels 201 thru 206)
RHFEb	right hand forward equipment bay (panels 200 and 207)

The controls/displays locator index is sub-divided as follows:

Guidance and Navigation	Page 3-5
Stabilization and Control	3-7
Service Propulsion System	3-9
Reaction Control	3-11
Electrical Power	3-13
Sequential Systems (ELS, LES, FDS, SECS)	3-17
Telecommunications	3-18
Environmental Control	3-20

CONTROLS AND DISPLAYS

Mission _____ Basic Date 12 Nov 1966 Change Date _____ Page 3-3

SM2A-03-SC012
APOLLO OPERATIONS HANDBOOK

CONTROLS AND DISPLAYS

	Page
Caution and Warning	3-23
Miscellaneous Systems	3-24
Scientific Experiments	3-25

CONTROLS AND DISPLAYS

Mission _____ Basic Date 12 Nov 1966 Change Date _____ Page 3-1

SM2A-03-SC012
APOLLO OPERATIONS HANDBOOK

GUIDANCE AND NAVIGATION SYSTEM-CONTROLS/DISPLAYS LOCATOR INDEX

Control/Display Name	Type	Panel Locator
ACCEL FAIL	Lt	LEB-103
ACTIVITY COMP	Lt	MDC-14, LEB-106
AGC MODE	Sw	LEB-107
AGC PWR FAIL	Lt	MDC-10, LEB-103
ATT CONT MODE	Lt	LEB-101
ATTITUDE IMPULSE	Control	LEB-105
ATTITUDE IMPULSE ENABLE	Sw	LEB-105
BRIGHTNESS	Control	MDC-14, LEB-106
CDU FAIL	Lt	MDC-10, LEB-103
CDU MAN MODE	Lt	LEB-101
CHECK CONDITION LAMPS	Sw	LEB-105
CHECK COOLANT	Sw	LEB-105
CHECK COOLANT	Windows (2)	LEB-105
CHECK FAIL	Lt	LEB-106
CHECK MODE LAMPS	Sw	LEB-105
CLEAR	Sw	MDC-14, LEB-106
COARS ALIGN MODE	Lt	LEB-101
COMP FAIL	Lt	MDC-14
COMPUTER	CB (2)	MDC-22
CONDITION LAMP	Sw	LEB-105
COUNTER FAIL	Lt	LEB-106
DOOR LATCH	Control	LEB-105
DSKY	Keys	MDC-14, LEB-106
ENTER	Sw	MDC-14, LEB-106
ENTRY MODE	Lt	LEB-101
ERROR RESET	Sw	MDC-14, LEB-106
FINE ALIGN MODE	Lt	LEB-101
GMBL LOCK	Lt	MDC-10, LEB-103
G&N ACCEL FAIL	Lt	MDC-10
G&N ERROR	Lt	MDC-10
G&N VIEWER	Sw	MDC-22
IMU-CDU DIFFERENCE	Ind	LEB-101
IMU	CB (2)	MDC-22
IMU DELAY	Lt	LEB-103
IMU FAIL	Lt	MDC-10, LEB-103
IMU HTR	CB (2)	MDC-22
IMU TEMP	Lt	MDC-10, LEB-103
IMU TEMP MODE GAIN IRIG	Sw	LEB-105
IMU TEMP MODE GAIN PIPA	Sw	LEB-105
IMU TEMP MODE	Mode sw	LEB-105
IMU TEMP MODE ZERO	Sw	LEB-105
INNER GIMBAL (PITCH)	Ind	LEB-102
KEY RLSE	Lt	MDC-14, LEB-106
KEY RLSE	Sw	MDC-14, LEB-106
MANUAL ALIGN	Lt	LEB-101
MARK	Sw	LEB-105
MASTER ALARM	Lt	MDC-3, LEB-103

GUIDANCE AND NAVIGATION SYSTEM-CONTROLS/DISPLAYS LOCATOR INDEX

Mission _____ Basic Date 12 Nov 1966 Change Date _____ Page 3-5

APOLLO OPERATIONS HANDBOOK

GUIDANCE AND NAVIGATION SYSTEM—CONTROLS/DISPLAYS LOCATOR INDEX

Control/Display Name	Type	Panel Locator
MIDDLE GIMBAL (YAW)	Ind	LEB-102
-(minus sign switch)	Sw	MDC-14, LEB-106
NOUN	Sw	MDC-14, LEB-106
NOUN	End	MDC-14, LEB-106
OPTICS	CB (2)	MDC-22
OPTICS CONTROLLER MODE	Sw	LEB-105
OPTICS CONTROLLER SPEED	Sw	LEB-105
Optics hand controller (no placard)	Control	LEB-105
OPTICS HOLD	Sw	LEB-105
OPTICS	Mode sw	LEB-105
OPTICS SLAVE TELESCOPE	Sw	LEB-105
OUTER GIMBAL (ROLL)	Ind	LEB-102
PANEL BRIGHTNESS	Control	LEB-105
PARITY FAIL	Lt	LEB-106
PGNS	Lt	LEB-103
+ (plus sign switch)	Sw	MDC-14, LEB-106
PROG ALM	Lt	LEB-106
PROGRAM	Ind	MDC-14, LEB-106
REGISTER 1	Ind	MDC-14, LEB-106
REGISTER 2	Ind	MDC-14, LEB-106
REGISTER 3	Ind	MDC-14, LEB-106
RUPT LOCK	Lt	LEB-106
Sextant (not placarded)	SXT	LEB-104
SCALER FAIL	Lt	LEB-106
SHAFT ANGLE	Ind	LEB-102, LEB-104
SHAFT	Manual drive	LEB-104
Telescope (not placarded)	SCT	LEB-104
TC TRAP	Lt	LEB-106
TM FAIL	Lt	LEB-106
TRANSFER	Sw	LEB-101
TRUNNION ANGLE	Ind	LEB-104
TRUNNION	Manual drive	LEB-104
UPTTEL ACCEPT BLOCK	Sw	MDC-14
VERB	Ind	MDC-14, LEB-106
VERB	Sw	MDC-14, LEB-106
VIEWER	CB (2)	MDC-22
ZERO ENCODE MODE	Lt	LEB-101
ZERO ENCODER	Lt	LEB-103
2X TRUNNION	Ind	LEB-102

GUIDANCE AND NAVIGATION SYSTEM—CONTROLS/DISPLAYS LOCATOR INDEX

Mission _____ Basic Date 12 Nov 1966 Change Date _____ Page 3-6

SM2A-03-SC012
 APOLLO OPERATIONS HANDBOOK

STABILIZATION AND CONTROL SYSTEM—CONTROLS/DISPLAYS LOCATOR INDEX

Control/Display Name	Type	Panel Locator
AGAP TEMP	Warn lt	MDC-10
ATT DEADBAND	Sw	MDC-8
ATT SET	Sw	MDC-6
ATTITUDE IMPULSE-ENABLE	Sw	LEB-105
ATTITUDE/MONITOR/ENTRY	Sw	MDC-8
ATTITUDE SET-ROLL, PITCH, YAW	Thumbwheel (3)	MDC-6
ATTITUDE SET-ROLL, PITCH, YAW	Ind (3)	MDC-6
BMAG POWER	Sw	MDC-24
C/W-NORMAL/BOOST/ACK	Sw	MDC-13
CAUT/WARN-MNA, MNB	CB (2)	MDC-25
CAUTION/WARNING-MODE	Sw	MDC-11
DIRECT RCS	Sw	MDC-8
DIRECT ULLAGE	Sw	MDC-7
FCSM AUTO/OVERRIDE	Sw	MDC-2
FCSM ON/RESET	Sw	MDC-2
FDAI	Ind	MDC-4
FDAI ALIGN	Sw	MDC-6
FDAI BRIGHTNESS	Control	MDC-2
FDAI LTG	Sw	MDC-25
FDAI SELF TEST	Sw	MDC-2
.05G ENTRY	Sw	MDC-8
GIMBAL POSITION	Ind	MDC-6
G&N/SCS	Sw	MDC-8
G&N SYNC	Sw	MDC-25
LCL VERT	Sw	MDC-8
LIMIT CYCLE	Sw	MDC-8
MASTER EVENT SEQ CONT-A LOGIC B- BAT A, BAT B	CB (2)	MDC-22
NORMAL/OFF/DIRECT ON	Sw	MDC-7
PARTIAL SCS POWER	Sw	MDC-24
RATE GYRO POWER	Sw	MDC-24
RATE GYRO-ROLL, PITCH, YAW	Sw (3)	MDC-8
REACTION CONTROL SYS-TRANS Rotational Controllers (not placarded)	Sw Controls (2)	MDC-16 LH couch, RH arm- rest, RH couch, LH armrest
ROTATION CONTROL POWER	Sw	-24
SCS CHANNEL-A&C ROLL, B&D ROLL, PITCH, YAW	Sw (4)	MDC-8
STABILIZATION & CONTROL SYSTEM- A&C ROLL-MNA, MNB B&D ROLL-MNA, MNB DIRECT CONT-MNA, MNB GROUP 1-AC1, AC2 GROUP 1-MNA, MNB GROUP 2-AC1, AC2 GROUP 2-MNA, MNB	CB (18)	MDC-25

STABILIZATION AND CONTROL SYSTEM—CONTROLS/DISPLAYS LOCATOR INDEX

SM2A-03-SC012
 APOLLO OPERATIONS HANDBOOK

STABILIZATION AND CONTROL SYSTEM—CONTROLS/DISPLAYS LOCATOR INDEX

Control/Display Name	Type	Panel Locator
THRUST ON Translational Controllers (not placarded)	Sw Control (2)	MDC-7 LH couch, LH armrest
TVC 1 POWER	Sw	MDC-24
TVC 2 POWER	Sw	MDC-24
ΔV	Sw	MDC-8
ΔV REMAINING	Ind	MDC-7
ΔV SET	Sw	MDC-7
YAW, PITCH	Thumbwheel (2)	MDC-6

STABILIZATION AND CONTROL SYSTEM—CONTROLS/DISPLAYS LOCATOR INDEX

SERVICE PROPULSION SYSTEM - CONTROLS/DISPLAYS LOCATOR INDEX

Control/Display Name	Type	Panel Locator
ABORT SYSTEM-TWR JETT SPS MODE-A (B)	Sw	MDC-16
two		
CAUT/WARN-MNA (MNB)	CB (2)	MDC-25
ΔV	Sw	MDC-8
ΔV REMAINING	Sw	MDC-7
ΔV SET	Sw	MDC-7
DIRECT ULLAGE	Sw	MDC-7
FCSM-G&N	Sw	MDC-2
FCSM-SCS	Sw	MDC-2
G&N/SCS	Sw	MDC-8
GIMBAL POSITION-PITCH	Ind	MDC-6
GIMBAL POSITION-PITCH	Thumbwheel	MDC-6
GIMBAL POSITION-YAW	Ind	MDC-6
GIMBAL POSITION-YAW	Thumbwheel	MDC-6
H _e TANK-PRESS	Ind	MDC-20
H _e TANK-TEMP	Ind	MDC-20
INSTRUMENTS-ESS-MNA (MNB)	CB (2)	MDC-22
L/V AOA/SPS P _c	Ind	MDC-3
L/V AOA/SPS P _c	Sw	MDC-3
MASTER EVENT SEQ CONT-A LOGIC B-BAT A (BAT B)	CB (2)	MDC-22
NORMAL/OFF/DIRECT ON (Thrust)	Sw	MDC-7
OXID FLOW	Sw	MDC-20
OXID FLOW-DECREASE	Ind	MDC-20
OXID FLOW-INCREASE	Ind	MDC-20
PITCH GMBL DR FAIL	Status lts	MDC-11
PRESSURE-ENG INLET-FUEL	Ind	MDC-20
PRESSURE-ENG INLET-OX	Ind	MDC-20
PRESSURE-FUEL	Ind	MDC-20
PRESSURE-OX	Ind	MDC-20
QUANTITY-FUEL	Display	MDC-20
QUANTITY-OXID	Display	MDC-20
SENSOR	Sw	MDC-20
SERVICE PROPULSION SYSTEM-		
GAUGING-AC1 (AC2)	CB (2)	MDC-25
GAUGING-MNA (MNB)	CB (2)	MDC-25
GIMBAL MOTOR CONTROL -1 PITCH		
-BAT A (PITCH 2-BAT B)	CB (2)	MDC-25
GIMBAL MOTOR CONTROL -1 YAW		
-BAT A (YAW 2-BAT B)	CB (2)	MDC-25
H _e VALVE-MNA (MNB)	CB (2)	MDC-25
SPS ENGINE INJECT VALVE -1 (2, 3, 4)	Ind (4)	MDC-20
SPS GAUGING	Sw	MDC-25
SPS HELIUM (left hand and right hand)	Ind (2)	MDC-20
SPS HELIUM (left hand and right hand)	Sw (2)	MDC-20
SPS-INJECT PRE-VALVES-A (B)	Sw (2)	MDC-3
SPS-GIMBAL MOTORS -1 PITCH (PITCH 2)	Sw (2)	MDC-3

SERVICE PROPULSION SYSTEM - CONTROLS/DISPLAYS LOCATOR INDEX

SM2A-03-SC012
 APOLLÓ OPERATIONS HANDBOOK

SERVICE PROPULSION SYSTEM-CONTROLS/DISPLAYS LOCATOR INDEX

Control/Display Name	Type	Panel Locator
SPS-GIMBAL MOTORS -1 YAW (YAW 2)	Sw (2)	MDC-3
SPS LINE HTR	Sw	MDC-19
SPS PRESS	Status lts	MDC-11
SPS PU SNSR FAIL	Status lts	MDC-11
SPS ROUGH ECO	Status lts	MDC-10
SPS TANK PRESS	Sw	MDC-20
STABILIZATION & CONTROL SYSTEM		
-DIRECT CONT-MNA (MNB)	CB (2)	MDC-25
-1 GROUP-AC 1 (GROUP 2-AC 2)	CB (2)	MDC-25
-1 GROUP-MNA (GROUP 2-MNB)	CB (2)	MDC-25
TELECOMMUNICATIONS-GROUP 5	CB	MDC-22
TEST/AUTO/TEST (propellant quantity)	Sw	MDC-20
THRUST ON	Switch-light	MDC-7
TK PRESS-N ₂	Ind	MDC-20
UNBALANCE	Ind	MDC-20
VALVE	Sw	MDC-20

SERVICE PROPULSION SYSTEM-CONTROLS/DISPLAYS LOCATOR INDEX

SM2A-03-SC012
APOLLO OPERATIONS HANDBOOK

REACTION CONTROL SYSTEM-CONTROLS/DISPLAYS LOCATOR INDEX

Control/Display Name	Type	Panel Locator
ABORT SYSTEM-OX DUMP	Sw	MDC-16
CM PROP JETT-DUMP	Sw	MDC-8
CM PROP JETT-LOGIC	Sw	MDC-8
CM PROP JETT-PURGE	Sw	MDC-8
C/M RCS	Sw	MDC-26
C/M RCS A	Status lts	MDC-10
C/M RCS B	Status lts	MDC-10
C/M RCS HTRS	Sw	RHFEB-200
C/M RCS PRESS F	Ind	MDC-12
C/M RCS TEMP H _e	Ind	MDC-12
C/M RCS PRESS OX	Ind	MDC-12
C/M RCS PRPLNT-A	Sw	MDC-15
C/M RCS PRPLNT-A	Event ind	MDC-15
C/M RCS PRPLNT-B	Sw	MDC-15
C/M RCS PRPLNT-B	Event ind	MDC-15
C/M RCS TEMP H _e	Ind	MDC-12
C/M-S/M-SEP-A (B)	Sw (2)	MDC-15
DIRECT RCS	Sw	MDC-8
INSTRUMENTS-ESS-MNA (MNB)	CB (2)	MDC-22
MASTER EVENT SEQ CONT		
-A ARM B-BAT A (BAT B)	CB (2)	MDC-22
-A LOGIC B-BAT A (BAT B)	CB (2)	MDC-22
PROPELLANT QUANTITY-FUEL (bottom window)	Digital ind	MDC-12
PROPELLANT QUANTITY-OXIDIZER (top window)	Digital ind	MDC-12
PYRO A-RCS FUEL DUMP	CB	LEB-150
PYRO B-RCS FUEL DUMP	CB	LEB-150
RCS HEATERS-A MNB	CB	MDC-21
RCS HEATERS-B MNA	CB	MDC-21
RCS HEATERS-C MNB	CB	MDC-21
RCS HEATERS-D MNA	CB	MDC-21
RCS INDICATORS selector		
C/M section	Sw	MDC-12
S/M section	Sw	MDC-12
REACTION CONTROL SYS-CMD	Sw	MDC-16
REACTION CONTROL SYS-C/M PRESS	Sw	MDC-16
REACTION CONTROL SYS-TRANS	Sw	MDC-16
REACTION CONTROL SYSTEM		
-C/M-S/M TRANSFER-MNA (MNB)	CB (2)	MDC-25
-GAUGING-MNA (MNB)	CB (2)	MDC-25
-PROP ISOL-MNA (MNB)	CB (2)	MDC-25
S/M RCS-A (B, C, D)-HELIUM 1	Sw (4)	MDC-15
S/M RCS-A (B, C, D)-HELIUM 1	Event ind (4)	MDC-15
S/M RCS-A (B, C, D)-HELIUM 2	Sw (4)	MDC-15
S/M RCS-A (B, C, D)-HELIUM 2	Event ind (4)	MDC-15
S/M RCS PRESS H _e	Ind	MDC-12

REACTION CONTROL SYSTEM-CONTROLS/DISPLAYS LOCATOR INDEX

Mission _____ Basic Date 12 Nov 1966 Change Date _____ Page 3-11

SM2A-03-SC012
 APOLLO OPERATIONS HANDBOOK

REACTION CONTROL SYSTEM—CONTROLS/DISPLAYS LOCATOR INDEX

Control/Display Name	Type	Panel Locator
S/M RCS PRESS MANF	Ind	MDC-12
S/M RCS-A (B, C, D)-PROPELLANT	Event ind (4)	MDC-15
S/M RCS-A (B, C, D)-PROPELLANT	Sw (4)	MDC-15
S/M RCS TEMP PKG	Ind	MDC-12
S/M RCS A	Status lts	MDC-10
S/M RCS B	Status lts	MDC-10
S/M RCS C	Status lts	MDC-10
S/M RCS D	Status lts	MDC-10

REACTION CONTROL SYSTEM—CONTROLS/DISPLAYS LOCATOR INDEX

Mission _____ Basic Date 12 Nov 1966 Change Date _____ Page 3-12

SM2A-03-SC012
APOLLO OPERATIONS HANDBOOK

ELECTRICAL POWER SYSTEM—CONTROLS/DISPLAYS LOCATOR INDEX

Control/Display Name	Type	Panel Locator
AC BUS 1 FAIL	Lt	MDC-11
AC BUS 2 FAIL	Lt	MDC-11
AC BUS 1 OVERLOAD	Lt	MDC-11
AC BUS 2 OVERLOAD	Lt	MDC-11
AC INDICATORS	Sw	MDC-18
AC INVERTER—AC BUS 1-RESET	Sw	MDC-18
AC INVERTER—AC BUS 2-RESET	Sw	MDC-18
AC INVERTER—1	Sw	MDC-18
AC INVERTER—1-AC BUS 1	Sw	MDC-18
AC INVERTER—1-AC BUS 2	Sw	MDC-18
AC INVERTER—2	Sw	MDC-18
AC INVERTER—2-AC BUS 1	Sw	MDC-18
AC INVERTER—2-AC BUS 2	Sw	MDC-18
AC INVERTER—3	Sw	MDC-18
AC INVERTER—3-AC BUS 1	Sw	MDC-18
AC INVERTER—3-AC BUS 2	Sw	MDC-18
AC SNSR SIG-AC1	CB	MDC-25
AC SNSR SIG-AC2	CB	MDC-25
AC VOLTS	Meter	MDC-18
BAT A PWR-ENTRY	CB	LEB-150
BAT B PWR-ENTRY	CB	LEB-150
BAT CHGR	Sw	MDC-22
BAT CHGR-BAT C	CB	LEB-150
BAT C PWR-POSTLANDING ENTRY	CB	LEB-150
BAT RLY BUS-BAT A	CB	MDC-22
BAT RLY BUS-BAT B	CB	MDC-22
BATTERY CHARGER	Sw	MDC-18
BATTERY CHARGER-AC PWR	CB	MDC-22
BATTERY CHARGER-BAT A CHGE	CB	MDC-22
BATTERY CHARGER-BAT B CHGE	CB	MDC-22
BATTERY CHARGER-MNA	CB	MDC-22
BATTERY CHARGER-MNB	CB	MDC-22
CRYOGENIC SYSTEM-QTY AMPL-AC 1-0C	CB	MDC-22
CRYOGENIC SYSTEM-QTY AMPL-AC 2-0C	CB	MDC-22
CRYOGENIC SYSTEM-TANK HEATERS-H ₂	CB	MDC-22
CRYOGENIC SYSTEM-TANK HEATERS-O ₂	CB	MDC-22
CRYOGENIC TANK FAN MOTORS-AC 1-0A	CB	MDC-22
CRYOGENIC TANK FAN MOTORS-AC 1-0B	CB	MDC-22
CRYOGENIC TANK FAN MOTORS-AC 1-0C	CB	MDC-22
CRYOGENIC TANK FAN MOTORS-AC 2-0A	CB	MDC-22
CRYOGENIC TANK FAN MOTORS-AC 2-0B	CB	MDC-22
CRYOGENIC TANK FAN MOTORS-AC 2-0C	CB	MDC-22
DC AMPS	Meter	MDC-18
DC INDICATORS	Sw	MDC-18
DC SNSR SIG-MNA	CB	MDC-22
DC SNSR SIG-MNB	CB	MDC-22
DC VOLTS	Meter	MDC-18

ELECTRICAL POWER SYSTEM—CONTROLS/DISPLAYS LOCATOR INDEX

SM2A-03-SC012
APOLLO OPERATIONS HANDBOOK

ELECTRICAL POWER SYSTEM-CONTROLS/DISPLAYS LOCATOR INDEX

Control/Display Name	Type	Panel Locator
DC VOLTS (auxiliary)	Meter	RHFEB-200
F/C-BUS DISCONNECT	Lt	MDC-11
F/C RAD TEMP LOW	Ind	MDC-18
F/C VALVES	Sw	MDC-19
F/C 1	Lt	MDC-11
F/C 2	Lt	MDC-11
F/C 3	Lt	MDC-11
FREQUENCY	Meter	MDC-18
FUEL CELL-FLOW-H ₂	Ind	MDC-18
FUEL CELL-FLOW-O ₂	Ind	MDC-18
FUEL CELL INDICATORS	Sw	MDC-18
FUEL CELL-MAIN BUS A-RESET	Sw	MDC-18
FUEL CELL-MAIN BUS B-RESET	Sw	MDC-18
FUEL CELL-MODULE TEMP-COND EXH	Ind.	MDC-18
FUEL CELL-MODULE TEMP-SKIN	Ind	MDC-18
FUEL CELL 1-BUS CONT	CB	MDC-22
FUEL CELL 1-CIR & SEP MOTORS	CB.	MDC-22
FUEL CELL 1-H ₂ &O ₂ VALVE	CB	MDC-22
FUEL CELL 1-PURGE	CB	MDC-22
FUEL CELL-1-MAIN BUS A	Ind	MDC-18
FUEL CELL-1-MAIN BUS A	Sw	MDC-18
FUEL CELL-1-MAIN BUS B	Ind	MDC-18
FUEL CELL-1-MAIN BUS B	Sw	MDC-18
FUEL CELL-1 purge	Sw	MDC-18
FUEL CELL-1-REACTANTS	Ind	MDC-18
FUEL CELL-1-REACTANTS	Sw	MDC-18
FUEL CELL 2-BUS CONT	CB	MDC-22
FUEL CELL 2-CIR & SEP MOTORS	CB	MDC-22
FUEL CELL 2-H ₂ &O ₂ VALVE	CB	MDC-22
FUEL CELL 2-PURGE	CB	MDC-22
FUEL CELL-2-MAIN BUS A	Ind	MDC-18
FUEL CELL-2-MAIN BUS A	Sw	MDC-18
FUEL CELL-2-MAIN BUS B	Ind	MDC-18
FUEL CELL-2-MAIN BUS B	Sw	MDC-18
FUEL CELL-2 purge	Sw	MDC-18
FUEL CELL-2-REACTANTS	Ind	MDC-18
FUEL CELL-2-REACTANTS	Sw	MDC-18
FUEL CELL 3-BUS CONT	CB	MDC-22
FUEL CELL 3-CIR & SEP MOTORS	CB	MDC-22
FUEL CELL 3-H ₂ &O ₂ VALVE	CB	MDC-22
FUEL CELL 3-PURGE	CB	MDC-22
FUEL CELL-3-MAIN BUS A	Ind	MDC-18
FUEL CELL-3-MAIN BUS A	Sw	MDC-18
FUEL CELL-3-MAIN BUS B	Ind	MDC-18
FUEL CELL-3-MAIN BUS B	Sw	MDC-18
FUEL CELL-3 purge	Sw	MDC-18
FUEL CELL-3-REACTANTS	Ind	MDC-18
FUEL CELL-3-REACTANTS	Sw	MDC-18

ELECTRICAL POWER SYSTEM-CONTROLS/DISPLAYS LOCATOR INDEX

SM2A-03-SC012
APOLLO OPERATIONS HANDBOOK

ELECTRICAL POWER SYSTEM-CONTROLS/DISPLAYS LOCATOR INDEX

Control/Display Name	Type	Panel Locator
FUEL CELL PUMP-1	Sw	MDC-22
FUEL CELL PUMP-2	Sw	MDC-22
FUEL CELL PUMP-3	Sw	MDC-22
FUNCTION SELECT	Sw	RHFEB-200
H ₂ FANS-1	Sw	MDC-13
H ₂ FANS-2	Sw	MDC-13
H ₂ HEATERS-1	Sw	MDC-13
H ₂ HEATERS-2	Sw	MDC-13
H ₂ PRESS	Lt	MDC-10
INVERTER CONTROL-1	CB	MDC-22
INVERTER CONTROL-2	CB	MDC-22
INVERTER CONTROL-3	CB	MDC-22
INVERTER PWR-NO. 1 MNA	CB	RHEB-203
INVERTER PWR-NO. 2 MNB	CB	RHEB-203
INVERTER PWR-NO. 3 MNA	CB	RHEB-203
INVERTER PWR-NO. 3 MNB	CB	RHEB-203
INV 1 TEMP HI	Lt	MDC-11
INV 2 TEMP HI	Lt	MDC-11
INV 3 TEMP HI	Lt	MDC-11
MAIN A-BAT BUS A	CB	RHEB-203
MAIN A-BAT C	CB	RHEB-203
MAIN B-BAT BUS B	CB	RHEB-203
MAIN B-BAT C	CB	RHEB-203
MAIN BUS TIE-BAT A&C	Sw	MDC-22
MAIN BUS TIE-BAT B&C	Sw	MDC-22
MIN BUS A UNDERVOLT	Lt	MDC-11
MIN BUS B UNDERVOLT	Lt	MDC-11
NON ESS BUS	Sw	MDC-22
O ₂ FANS-1	Sw	MDC-13
O ₂ FANS-2	Sw	MDC-13
O ₂ HEATERS-1	Sw	MDC-13
O ₂ HEATERS-2	Sw	MDC-13
O ₂ PRESS	Lt	MDC-10
pH HI	Ind	MDC-18
POST LDG-BAT BUS A	CB	RHEB-203
POST LDG-BAT BUS B	CB	RHEB-203
POST LDG-BAT C	CB	RHEB-203
POST LDG-MAIN A	CB	RHEB-203
POST LDG-MAIN B	CB	RHEB-203
REG OUT PRESS HI-H ₂	Ind	MDC-18
REG OUT PRESS HI-N ₂	Ind	MDC-18
REG OUT PRESS HI-O ₂	Ind	MDC-18
SNSR UNIT-AC BUS-1	CB	MDC-21
SNSR UNIT-AC BUS-2	CB	MDC-21
SNSR UNIT-DC BUS-A	CB	MDC-21
SNSR UNIT-DC BUS-B	CB	MDC-21

ELECTRICAL POWER SYSTEM-CONTROLS/DISPLAYS LOCATOR INDEX

SM2A-03-SC012
 APOLLO OPERATIONS HANDBOOK

ELECTRICAL POWER SYSTEM—CONTROLS/DISPLAYS LOCATOR INDEX

Control/Display Name	Type	Panel Locator
TANK PRESSURE-H ₂ -1	Ind	MDC-13
TANK PRESSURE-H ₂ -2	Ind	MDC-13
TANK PRESSURE-O ₂ -1	Ind	MDC-13
TANK PRESSURE-O ₂ -2	Ind	MDC-13
TANK QUANTITY-H ₂ -1	Ind	MDC-13
TANK QUANTITY-H ₂ -2	Ind	MDC-13
TANK QUANTITY-O ₂ -1	Ind	MDC-13
TANK QUANTITY-O ₂ -2	Ind	MDC-13
TEST SELECT	Sw	RHFEB-200
H ₂ PURGE LINE HTR	Sw	MDC-15
INV. PHASE LOCK	Sw	RHEB 208

ELECTRICAL POWER SYSTEM—CONTROLS/DISPLAYS LOCATOR INDEX

SM2A-03-SC012
APOLLO OPERATIONS HANDBOOK

SEQUENTIAL SYSTEMS— CONTROLS/DISPLAYS LOCATOR INDEX

Control/Display Name	Type	Panel Locator
ABORT	Lt	MDC-3
ABORT SYSTEM-MODE	Sw (2)	MDC-10
ABORT SYSTEM-L/V RATES	Sw	MDC-10
ABORT SYSTEM-ON DUMP	Sw	MDC-10
ABORT SYSTEM-2 ENG OUT	Sw	MDC-10
ADAPT SEP	Sw	MDC-5
ALTIMETER	Indicator	MDC-1
APEX COVER JETT	Sw	MDC-5
CANARD DEPLOY	Sw	MDC-5
C/M-S/M SEP	Sw (2)	MDC-15
COUCH UNLOCK	Sw	MDC-8
Digital Event Timer Indicator (no placard)	Window	MDC-5
DIGITAL EVENT TIMER-MIN	Sw	MDC-8
DIGITAL EVENT TIMER-RESET	Sw	MDC-8
DIGITAL EVENT TIMER-SEC	Sw	MDC-8
DIGITAL EVENT TIMER-START	Sw	MDC-8
Digital Event Timer Indicator (no placard)	Window	MDC-11
DIGITAL EVENT TIMER-MIN	Sw	MDC-11
DIGITAL EVENT TIMER-RESET	Sw	MDC-11
DIGITAL EVENT TIMER-SEC	Sw	MDC-11
DIGITAL EVENT TIMER-START	Sw	MDC-11
DROGUE DEPLOY	Sw	MDC-5
EDS	Sw	MDC-10
EDS	CB (3)	MDC-25
EDS POWER	Sw	MDC-24
ELS	CB (3)	MDC-25
ELS LOGIC	Sw	MDC-8
EVENT TIMER	CB (2)	MDC-25
LES MOTOR FIRE	Sw	MDC-5
LIFT-OFF	Lt	MDC-5
LOCK/UNLOCK	Control	MDC-5
L V AOA/SPS PC	Ind	MDC-3
L V AOA/SPS PC	Sw	MDC-3
L V ENGINE	Lt (8)	MDC-5
L V GUID	Lt	MDC-5
L V RATE	Lt	MDC-5
MAIN CHUTE RELEASE	Sw	MDC-10
MAIN DEPLOY	Sw	MDC-5
MAIN DEPLOY-AUTO	Sw	MDC-10
MASTER EVENT SEQ CONT-ARM	CB (2)	MDC-22
MASTER EVENT SEQ CONT-LOGIC	CB (2)	MDC-22
MASTER EVENT SEQ CONT-PYRO ARM	Sw (2)	MDC-24
MESC-LOGIC ARM	Sw (2)	MDC-25
NO AUTO ABORT	Lt	MDC-5
POST LDG BEACON LIGHTS	Sw	MDC-20
PYRO A-RCS FUEL DUMP	CB	LEB-150
PYRO A-SEQ A	CB	LEB-150
PYRO B-RCS FUEL DUMP	CB	LEB-150
PYRO B-SEQ B	CB	LEB-150

SEQUENTIAL SYSTEMS—CONTROLS/DISPLAYS LOCATOR INDEX

SM2A-03-SC012
 APOLLO OPERATIONS HANDBOOK

TELECOMMUNICATIONS-CONTROLS/DISPLAYS LOCATOR INDEX

Control/Display Name	Type	Panel Locator
BIO-MED COMM-MNA	CB	MDC-25
BIO-MED COMM-MNB	CB	MDC-25
C-BAND	Sw	MDC-20
CENTRAL TIMING SYS-MNA	CB	MDC-22
CENTRAL TIMING SYS-MNB	CB	MDC-22
FLIGHT QUAL RCDR	Sw	MDC-19
RCDR/HF	Sw	MDC-13, -23, -26
INST PWR CONT		RHEB-204
ESSENTIAL 1 THRU 4	CB (4)	
NON-ESSENTIAL 5 THRU 10	CB (6)	
INSTRUMENTS-ESS-MNA	CB	MDC-22
INSTRUMENTS-ESS-MNB	CB	MDC-22
INSTRUMENTS-NONESS	CB	MDC-22
INSTRUMENTS-NONESS BUS	CB	MDC-22
INSTRUMENTS-R CDR.NONESS	CB	MDC-22
INSTRUMENTS-SCIEN	CB	MDC-22
INTERCOM	Sw	MDC-13, -23, -26
INTERCOM BALANCE	Sw	MDC-13, -23, -26
NONESS BUS	Sw	MDC-22
POSTLANDING ANTENNA DEPLOY	Sw	MDC-25
POWER		MDC-13, -23, -26
POWER-PMP	Sw	MDC-20
POWER-SCE	Sw	MDC-20
RECOVERY-HF-ON/OFF	Sw	MDC-20
RECOVERY-HF-SSB/BCN/AM	Sw	MDC-20
RECOVERY-VHF BCN	Sw	MDC-20
S-BAND	Sw	MDC-13, -23, -26
S-BAND ANT	Ind	MDC-19
S-BAND ANTENNA	Sw	MDC-20
S-BAND-EMERG	Sw	MDC-20
S-BAND-OSC	Sw	MDC-20
S-BAND-PWR AMPL	Sw	MDC-20
S-BAND-VOICE-RNG/RNG ONLY	Sw	MDC-20
S-BAND-VOICE-TAPE	Sw	MDC-20
S-BAND-VOICE-TV	Sw	MDC-20
S-BAND-XPONDER/XPONDER PWR AMPL	Sw	MDC-20
TAPE RECORDER-FWD/REV	Sw	MDC-20
TAPE RECORDER-PLAY	Sw	MDC-20
TAPE RECORDER-RECORD/PLAY	Sw	MDC-20
TAPE RECORDER-SPEED	Sw	MDC-20
TELECOM-ESS	Sw	MDC-22
TELECOM-NONESS	Sw	MDC-22
TELECOMMUNICATIONS-GROUP 1 AC	CB	MDC-22
TELECOMMUNICATIONS-GROUP 2 AC	CB	MDC-22
TELECOMMUNICATIONS-GROUP 3	CB	MDC-22
TELECOMMUNICATIONS-GROUP 4	CB	MDC-22
TELECOMMUNICATIONS-GROUP 5	CB	MDC-22

TELECOMMUNICATIONS-CONTROLS/DISPLAYS LOCATOR INDEX

SM2A-03-SC012
 APOLLO OPERATIONS HANDBOOK

TELECOMMUNICATIONS-CONTROLS/DISPLAYS LOCATOR INDEX

Control/Display Name	Type	Panel Locator
TELECOMMUNICATIONS-PCM TLM AC	CB	MDC-22
TELECOMMUNICATIONS-SIG COND S-BAND PA AC	CB	MDC-22
TLM INPUTS-BIOMED	Sw	MDC-20
TLM INPUTS-PCM	Sw	MDC-20
UP DATA	Sw	MDC-20
UP TLM CMD	Sw	MDC-19
VHF-AM	Sw	MDC-13, -23, -26
VHF-AM RCVR	Sw	MDC-20
VHF-AM SQUELCH	Control	MDC-20
VHF-AM-T/R/REC	Sw	MDC-20
VHF-ANTENNA	Sw	MDC-20
VHF-FM	Sw	MDC-20
VOICE RECORD	Indicator	MDC-19
VOLUME	Control	MDC-13, -23, -26
VOX SENS	Control	MDC-13, -23, -26

TELECOMMUNICATIONS-CONTROLS/DISPLAYS LOCATOR INDEX.

APOLLO OPERATIONS HANDBOOK

ENVIRONMENTAL CONTROL SYSTEM—CONTROLS/DISPLAYS LOCATOR INDEX

Control/Display Name	Type	Panel Locator
BATTERY VENT	Valve	RHEB-203
Cabin air control louver	Control	LHFEB-303
CABIN AIR/AUTO/SUIT AIR	Sw	LEB-120
CABIN AIR FAN-1 & 2	Sw (2)	MDC-21
CABIN PRESSURE RELIEF	Valve (2)	LHEB-307
CABIN REPRESS	Valve	LHEB-314
CABIN TEMP	Valve	LHFEB 303
CABIN TEMP-AUTO	Control	MDC-13
CABIN TEMP-AUTO/MAN	Sw	MDC-13
CO ₂ -odor absorber diverter	Valve	LHEB-313
CO ₂ PP HI	Light	MDC-11
DIRECT O ₂	Valve	MDC-24
DRINKING WATER SUPPLY	Valve	LHFEB-304
ΔP SUIT COMPR	Ind	MDC-13
ECS-CABIN AIR FAN-1 & 2	CB (6)	MDC-22
ECS-GLYCOL PUMPS-AC 1 & AC 2	CB (6)	MDC-22
ECS-GLYCOL-PUMP 1/PUMP 2	Sw (2)	MDC-21
ECS-H ₂ O ACCUM-MNA & MNB	CB (2)	MDC-22
ECS-POT H ₂ O HTR-MNA & MNB	CB (2)	MDC-22
ECS-RADIATOR	Sw (4)	MDC-21
ECS RAD-OUTLET TEMP	Ind	MDC-13
ECS RAD OUT TEMP-1 & 2	Ind (2)	MDC-19
ECS-RAD VALVE-AC 1 & AC 2	CB (4)	MDC-22
ECS STEAM DUCT HTR-MNA & MNB	CB (2)	RHEB-206
ECS-SUIT COMPRESSORS-AC 1 & AC 2	CB (6)	MDC-22
ECS-TRANSDUCER-PRESS GROUPS 1 & 2	CB (4)	MDC-22
ECS-TRANSDUCER-TEMP-MNA & MNB	CB (2)	MDC-22
ECS-TRANSDUCER-WASTE & POT H ₂ O-MNA & MNB	CB (2)	MDC-22
EMERGENCY CABIN PRESSURE	Valve	LHEB-314
EVAP H ₂ O	Valve	LHEB-311
FLOW O ₂	Ind	MDC-13
FOOD PREPARATION WATER-COLD & HOT	Valve (2)	LHFEB-305
GAS ANAL	CB	MDC-22
GLY ACCUM-QUANTITY	Ind	MDC-13
GLY EVAP WATER CONTROL BYPASS	Valve	LHEB-317
GLYCOL ACCUMULATOR	Valve	LHEB-312
GLYCOL EVAP-H ₂ O FLOW	Sw	MDC-13
GLYCOL EVAP-STEAM PRESS-AUTO/MAN	Sw	MDC-13
GLYCOL EVAP-STEAM PRESS-INCR/DECR	Sw	MDC-13
GLYCOL EVAP-STEAM PRESS-TEMP IN	Sw	MDC-13
GLYCOL EVAP TEMP IN	Valve	LHEB-311
GLYCOL PRESS RELIEF BYPASS-1 & 2	Valve (2)	LHEB-309
GLYCOL RESERVE	Valve	LHEB-311
GLYCOL RESERVOIR-BYPASS	Valve	LHEB-307
GLYCOL RESERVOIR-INLET	Valve	LHEB-307
GLYCOL RESERVOIR-OUTLET	Valve	LHEB-307
GLYCOL TEMP LOW	Light	MDC-11

ENVIRONMENTAL CONTROL SYSTEM—CONTROLS/DISPLAYS LOCATOR INDEX

SM2A-03-SC012
APOLLO OPERATIONS HANDBOOK

ENVIRONMENTAL CONTROL SYSTEM—CONTROLS/DISPLAYS LOCATOR INDEX

Control/Display Name	Type	Panel Locator
GLYCOL TO RAD	Valve	LHEB-307
GLY EVAP-OUTLET TEMP	Ind	MDC-13
GLY EVAP STEAM PRESS	Ind	MDC-13
H ₂ O ACCUM-AUTO/MAN	Sw	MDC-13
H ₂ O ACCUM FAIL	Light	MDC-11
H ₂ O ACCUM-ON 1/ON 2	Sw	MDC-13
H ₂ O ACCUMULATOR-1 & 2	Valve (2)	LHEB-311
H ₂ O IND	Sw	MDC-13
INST PWR CONT-ESSENTIAL 2	CB	RHEB-204
MAIN REGULATOR	Valve	LHEB-314
O ₂ FLOW HI	Light	MDC-11
O ₂ PRESS IND	Sw	MDC-13
OXYGEN-ENTRY	Valve	LHEB-307
OXYGEN-S/M SUPPLY	Valve	LHEB-307
OXYGEN-SURGE TANK	Valve	LHEB-307
PART PRESS CO ₂	Ind	MDC-13
PGA pressure	Ind (3)	PGA sleeve
PLSS FILL	Valve	LHEB-314
PLVC	Sw	LHEB-316
POST LANDING-VENT FAN	Sw	MDC-25
POST LANDING-VENT FAN-PL BUS/FLOAT BAG 2	CB	MDC-25
POTABLE TANK INLET	Valve	LHEB-315
POT H ₂ O HEATER	Sw	MDC-21
PRESS-CABIN	Ind	MDC-13
PRESS GLY DISCH	Ind	MDC-13
PRESS-SUIT	Ind	MDC-13
PRESSURE RELIEF	Valve	LHEB-315
START/OFF/PREHEAT	Sw	LHEB-120
Suit circuit return air	Valve	LHEB-319
SUIT COMPRESSOR-COMPR 1/COMPR 2	Sw	MDC-21
Suit demand pressure regulator selector	Valve	LHEB-310
SUIT EVAP	Sw	MDC-13
SUIT EVAP	Valve	LHEB-311
SUIT EVAP GLYCOL	Valve	LHEB-311
SUIT FLOW	Valve (3)	LHFEB-300, -301, -302
SUIT FLOW RELIEF	Valve	LHEB-311
SUIT HT EXCH	Sw	LHEB-310
SUIT TEST	Valve	LHEB-310
SURGE TANK PRESSURE RELIEF	Valve	LHEB-308
TANK PRESSURE-O ₂ -1	Ind	MDC-13
TEMP-CABIN	Ind	MDC-13
TEMP-SUIT	Ind	MDC-13
WASTE H ₂ O TK REFILL	Sw	MDC-13
WASTE MANAGEMENT-OVBD DRAIN	Valve	RHEB-201
WASTE MANAGEMENT-SELECTOR	Valve	RHEB-201

ENVIRONMENTAL CONTROL SYSTEM—CONTROLS/DISPLAYS LOCATOR INDEX

SM2A-03-SC012
 APOLLO OPERATIONS HANDBOOK

ENVIRONMENTAL CONTROL SYSTEM-CONTROLS/DISPLAYS LOCATOR INDEX

Control/Display Name	Type	Panel Locator
WASTE TANK INLET	Valve	LHEB-315
WASTE TANK SERVICING	Valve	LHEB 315
WATER & GLYCOL TANKS PRESSURE- REGULATOR-SELECTOR INLET	Valve	LHEB-314
WATER & GLYCOL TANKS PRESSURE- RELIEF-SELECTOR OUTLET	Valve	LHEB-314
WATER-QUANTITY	Ind	MDC-13

ENVIRONMENTAL CONTROL SYSTEM-CONTROLS/DISPLAYS LOCATOR INDEX

SM2A-03-SC012
 APOLLO OPERATIONS HANDBOOK

CAUTION AND WARNING SYSTEM-LOCATOR INDEX

Control/Display Name	Type	Panel Locator
AC BUS 1 FAIL	Lt	MDC-11
AC BUS 2 FAIL	Lt	MDC-11
AC BUS 1 OVERLOAD	Lt	MDC-11
AC BUS 2 OVERLOAD	Lt	MDC-11
AGAP TEMP	Lt	MDC-10
AGC PWR FAIL	Lt	MDC-10
CAUT/WARN-FAIL	Lt	MDC-11
CAUT/WARN-MNA & MNB	CB (2)	MDC-25
CAUT/WARN-MODE	Sw	MDC-11
CAUT/WARN-POWER	Sw	MDC-11
CDU FAIL	Lt	MDC-10
C/M RCS A	Lt	MDC-10
C/M RCS B	Lt	MDC-10
CO ₂ PP HI	Lt	MDC-11
C/W	Sw	MDC-13
C/W LAMP TEST	Sw	MDC-23
F/C 1	Lt	MDC-11
F/C 2	Lt	MDC-11
F/C 3	Lt	MDC-11
F/C BUS DISCONNECT	Lt	MDC-11
GLYCOL TEMP LOW	Lt	MDC-10
GMBL LOCK	Lt	MDC-10
G&N ACCEL FAIL	Lt	MDC-10
G&N ERROR	Lt	MDC-10
H ₂ O ACCUM FAIL	Lt	MDC-11
H ₂ PRESS	Lt	MDC-10
IMU FAIL	Lt	MDC-10
IMU TEMP	Lt	MDC-10
INV 1	Lt	MDC-11
INV 2	Lt	MDC-11
INV 3	Lt	MDC-11
MASTER ALARM	Lt	MDC-3
MASTER ALARM	Lt	MDC-18
MASTER ALARM	Lt	LEB-103
MN BUS A UNDERVOLT	Lt	MDC-11
MN BUS B UNDERVOLT	Lt	MDC-11
O ₂ FLOW HI	Lt	MDC-11
O ₂ PRESS	Lt	MDC-10
PITCH GMBL DR FAIL	Lt	MDC-11
S/M RCS A	Lt	MDC-10
S/M RCS B	Lt	MDC-10
S/M RCS C	Lt	MDC-10
S/M RCS D	Lt	MDC-10
SPS PRESS	Lt	MDC-11
SPS PU SNSR FAIL	Lt	MDC-11
SPS ROUGH ECO	Lt	MDC-10
SPS WALL TEMP HI	Lt	MDC-11
YAW GMBL DR FAIL	Lt	MDC-11

CAUTION AND WARNING SYSTEM-LOCATOR INDEX

SM2A-03-SC012
 APOLLO OPERATIONS HANDBOOK

MISCELLANEOUS SYSTEMS - CONTROLS/DISPLAYS LOCATOR INDEX

Controls/Display Name	Type	Panel Locator
COUCH ATTEN-FLOODLIGHTS	CB (2)	MDC-25
ELS-FLOAT BAG 3	CB	MDC-25
FLOODLIGHTS-PRIMARY	Sw	MDC-23
FLOODLIGHTS-SECONDARY	Sw	MDC-23
FLOODLIGHTS-PRIMARY	Sw	MDC-26
FLOODLIGHTS-SECONDARY	Sw	MDC-26
LIGHTING-CLOCKS	Sw	LEB-100
LIGHTING-FLOODS-PRIMARY	Sw	LEB-100
LIGHTING-FLOODS-SEC	Sw	LEB-100
POST LANDING-FLOAT BAG	Sw (3)	MDC-25
POST LANDING-FLOAT BAG 1 PL BUS	CB	MDC-25
POST LANDING-VENT FAN-PL BUS-FLOAT BAG 2	CB	MDC-25
UPRIGHTING SYSTEM-COMPR NO. 1 AND NO. 2	CB	RHEB-205

MISCELLANEOUS SYSTEMS - CONTROLS/DISPLAYS LOCATOR INDEX

SM2A-03-SC012
APOLLO OPERATIONS HANDBOOK

SCIENTIFIC EXPERIMENTS - CONTROLS/DISPLAYS LOCATOR INDEX

Controls/Display Name	Type	Panel Locator
SCIEN EQUIP SEB 1	CB	MDC-22
SCIEN EQUIP SEB 2	CB	MDC-22
INSTRUMENTS—SCIEN (not used)	CB	MDC-22
SCIEN EQUIP HATCH	CB	MDC-22

SCIENTIFIC EXPERIMENTS - CONTROLS/DISPLAYS LOCATOR INDEX

APOLLO OPERATIONS HANDBOOK

CONTROLS AND DISPLAYS

Location	Name and Position	Function	Circuit Breaker	Power Source	Telemetry Code No. and Identity	Remarks
MDC-1	AL TIME FER	Indicates altitude of command module up to 60,000 feet.	None	None	None	The altimeter is monitored to verify deployment of the drogue and main parachutes at the proper altitude. An adjustable marker on the dial is set prior to launch. The marker is used as a reference for manual deployment of the main parachutes during an abort initiated prior to 61 seconds after lift-off.
MDC-2	FCSM controls G&N/RESET/OVERRIDE switch G&N	Receives power from the SCS GROUP 1-MNA and R circuit breakers through the G&N mode switch, altitude mode switch, and AV switch in ON position. Applies power to the FCSM and the G&N, SCS AV gates. If unstable combustion is sensed, the FCSM automatically energizes relays that remove power from the G&N, SCS AV gates, automatically shutting the engine down; other relay contact points will illuminate the SPS ROUGH ECO caution and warning light on MDC-10.	SCS GROUP 1 MNA MNB	G&N switch altitude switch V switch ON	None	Two-position toggle switch. Placed in G&N position when G&N AV mode is utilized.
	RESET/OVERRIDE	Applies power to the G&N, SCS AV gates, bypassing the FCSM system. If unstable combustion is sensed, the SPS engine will not shut down and the SPS ROUGH ECO caution and warning light on MDC-10 will not illuminate. Will also be utilized to RESET the FCSM system if an automatic shutdown has occurred.				Placed to this position when SCS AV mode is utilized. The AV switch placed to OFF will also RESET the FCSM as a backup to the RESET/OVERRIDE position.
	SCS RESET/OVERRIDE switch	Receives power from the SCS GROUP 1 - MNA and B circuit breakers through the G&N mode switch, attitude mode switch, and the AV switch in ON position. Applies power to the FCSM and the SCS AV gates. If unstable combustion is sensed, the FCSM automatically energizes relays that remove power from the SCS AV gates, automatically shutting the engine down; other relay contact points will illuminate the SPS ROUGH ECO caution and warning light on MDC-10.				Two-position toggle switch. Placed in SCS position when SCS AV mode is utilized.

MAIN DISPLAY CONSOLE - PANELS 1 AND 2

Basic Date: 12 Nov 1966

Change Date

Page

3-26

SM2A-03-SC012
 APOLLO OPERATIONS HANDBOOK

CONTROLS AND DISPLAYS

Symbol	Label	Function	Circuit Breaker	Power Source	telemetry Code No. and Identity	Remarks
	RESET OVERRIDE	Applies power to the SCS ΔV motor by passing the FCSM system. If unstable combustion is sensed, the SPS engine will not shut down and the SPS ROUGH ECO caution and warning light on MIDC-10 will not illuminate. Will also be utilized to RESET the FCSM system if an automatic shutdown has occurred.	SCS - GROUP 1 MNA MNB	Ga.N switch attitude switch ΔV switch ON	None	Placed to this position when Ga.N ΔV mode is utilized. The ΔV switch placed to OFF would also RESET the FCSM as a backup to the RESET/OVERRIDE position.
	ONG ACCEL. indicator	Displays S/C positive and negative g loads along spacecraft X axis and records maximum g readings encountered. A RESET knob enables manual reset of recording pointers to normal 1g position.	(TBD)	(TBD)	(TBD)	The indicator has three pointers: one for normal g indications and the other two for recording maximum +g and -g readings, respectively. Scale +16 to -6g, readable increments 0.2g. Sensor is located behind instrument face.

MAIN DISPLAY CONSOLE - PANEL 2

SM2A-03-SC012
 APOLLO OPERATIONS HANDBOOK

CONTROLS AND DISPLAYS

Panel	Control Position	Function	Circuit Breaker	Power Source	Telemetry Code No. and Identify	Remarks
MDC-2 (Cont)	FDAI BRIGHTNESS control OFF INCR	Turns off FDAI panel lighting (white light) (MDC-4) and THRUST ON switch face lighting (MDC-7). Adjusts intensity of FDAI panel lighting and THRUST ON switch face lighting.	SCS— GROUP 2 AC 1 AC 2 (MDC-25)	A-C buses No. 1 and No. 2	None	
	FDAI SELF TEST switch SELF TEST (up) OFF	Normal SCS rate mode a. Removes rate gyro input from SCS rate electronics. b. Applies test signal to SCS rate electronics, causing negative deflection of all FDAI rate indicators to 4/5 full scale. Removes test signal from rate indicators and permits normal operation of FDAI.	SCS— GROUP 1 MN A MN B (MDC-25)	D-C main buses A and B		In backup SCS rate mode, the SCS rate electronics receive the sum of the SELF TEST and BMAG inputs. Therefore rate deflection will be 4/5 full scale (fixed) plus deflection caused by the analog of the rate signal, if any. SELF TEST is used each time, the FDAI is activated.
MDC-3	L/V AOA/SPS P _c switch L/V AOA SPS P _c L/V AOA/SPS P _c indicator	Connects output of Q-ball to L/V AOA/SPS P _c indicator. Connects output of SPS engine combustion chamber pressure sensor to L/V AOA/SPS P _c indicator. Time-shared indicator with input determined by position of L/V AOA/SPS P _c switch. a. L/V AOA input: the indicator displays a percentage of ΔP measured by the Q-ball which is a function of pitch and yaw.	None	N/A	None	Two-position toggle switch which enables the crew to select applicable input to L/V AOA/SPS P _c indicator. The switch is placed in the L/V AOA position prior to lift-off, and in the SPS P _c position at approximately 1 minute and 40 seconds after lift-off. Indicator range: 0 to 150%. Small changes in air pressures are sensed through four holes in the Q-ball. The indicator is monitored from 40 seconds to approximately one minute and 40 seconds after lift-off. It is red-lined at approximately 100 percent for the L/V AOA function. A decision for manual abort will be made when the indicator pointer reaches the red line and a movement is also noted on the FDAI.

MAIN DISPLAY CONSOLE—PANELS 2 AND 3

SM2A-03-SC012
 APOLLO OPERATIONS HANDBOOK

CONTROLS AND DISPLAYS

Location	Name and Position	Function	Circuit Breaker	Power Source	Telemetry Code No. and Identity	Remarks
MDC-3 (Cont)		b. SPS P _c input: the indicator displays SPS engine combustion chamber pressure during SPS thrusting as percentage of reference pressure value.	INSTRUMENTS— ESS MN A MN B (MDC-22)	D-C voltage from signal conditioner	SP0661P (Combustion chamber pressure sensor)	Reference pressure value for SPS P _c input is 100 psia (nominal). Normal thrusting readout is 100 percent. Scale is graduated in % increments.
	MASTER ALARM switch-light	Red light illuminates to alert crewman in Lf couch of a malfunction or out-of-tolerance condition. This is indicated by illumination of applicable system status lights on MDC-10 or -11.	CAUT/ WARN MN A MN B (MDC-25)	D-C main buses A and B	CS0150X (Master caution-warning on)	MASTER ALARM lights on MDC-3, -18, and LEB-103 are simultaneously illuminated and an audio alarm tone is sent to each headset. The C/W switch (MDC-13) is set to BOOST during the ascent phase only, preventing this MASTER ALARM switchlight from illuminating in order to avoid confusion with the adjacent red ABORT light. The switch-light loses its reset function during this time. The MASTER ALARM switch-light contains an integral pushbutton switch. Pressing the switch-light will reset the master alarm circuit, extinguishing the MASTER ALARM lights and shutting off the audio alarm.
	ABORT light	Illuminates red to indicate that an abort has been requested by the range safety officer or ground control.	EDS-1, 3 BAT A BAT B (MDC-25)	Battery buses A and B when the EDS POWER switch is ON (MDC-24)	BX0080X (EDS abort request A)	The light serves to alert the crew of an emergency situation where an abort is required immediately. The light is a backup to voice communications from ground control. Redundant bulbs are controlled by redundant commands through the UDL real-time command system.
	SPS switches GIMBAL MOTORS group PITCH 1, PITCH 2, YAW 1, YAW 2 switches START	Four operationally identical switches. Energizes motor switch in applicable overcurrent relay which, in turn, applies +28 vdc to the applicable gimbal actuator drive motor.	SPS— GIMBAL MOTOR CONTROL 1 PITCH BAT A PITCH 2 BAT B 1 YAW BAT A YAW 2 BAT B (MDC-25)	Battery buses A and B	None	Three-position toggle switch with upper (START) position spring-loaded to return switch to center (ON) position when released. PITCH 1 and YAW 1 switches control gimbal actuator primary drive motors. PITCH 2 and YAW 2 switches control gimbal actuator secondary drive motors. START position provides gimbal motor starting capability.

MAIN DISPLAY CONSOLE—PANEL 3

SM2A-03-SC012
APOLLO OPERATIONS HANDBOOK

CONTROLS AND DISPLAYS

Location	Label and Position	Function	Circuit Breaker	Power Source	Telemetry Code No. and Identity	Remarks
MDC-3 (Cont)	ON	Applies +28 vdc to over-under-current sensing circuitry in applicable overcurrent relay.	SPS - GIMBAL MOTOR CONTROL 1 PITCH BAT A PITCH 2 BAT B 1 YAW BAT A YAW 2 BAT B (MDC-25)	Battery buses A and B	None	ON position provides for over or undercurrent sensing (under 6 amps or over 40 amps nominal). During primary channel operation an over or undercurrent will automatically cause power to be removed from the primary drive motor, clutch commands switched to the secondary channel, and applicable GMBL DR FAIL status indicator to illuminate (MDC-11). During secondary operation, pitch 2 motor circuit is protected by CB 1 and yaw 2 motor circuit is protected by CB 2. CB 1 and CB 2 are 70 amp circuit breakers located in the S/M. No status indicators are provided for the secondary control circuits.
	OFF	Energizes motor switch in applicable overcurrent relay which removes +28 vdc from the current sensing circuitry and gimbal actuator drive motor.				
	INJECT PRE-VALVES group A (B) switch	Two operationally identical switches. Each switch controls the pneumatic (GN ₂) pressurization of the SPS engine valve-actuators within their respective half of a series/parallel propellant feed line configuration to the engine combustion chamber.	SPS-He VALVE MN A MN B (MDC-25)	D-C main buses A and B		During ascent, when GIMBAL MOTORS switches (4) are OFF, engine positioning is maintained by application of a quiescent current (60 +10, -5 ma) to the electromagnets of the extend and retract clutches when TVC 1 and 2 POWER switches (MDC 24) are on.
	ON	Applies +28 vdc to SPS engine system A pilot pre-valve solenoid.				Two-position toggle switch which must be in ON position (i.e., solenoid is actuated) before automatic or manual SPS engine valve-actuator control of the main propellant valves can be initiated.
	OFF	Removes +28 vdc from SPS engine system A pilot pre-valve solenoid.				

MAIN DISPLAY CONSOLE - PANEL 1

APOLLO OPERATIONS HANDBOOK

CONTROLS AND DISPLAYS

Location	Name and Position	Function	Circuit Breaker	Power Source	Telemetry Code No. and Identity	Remarks																
MDC-4	Flight director attitude indicator Total attitude indication	Displays S/C total attitude, attitude errors, and angular rates. S/C inertial attitude is displayed by orientation of the 3-axis attitude ball, with readouts as follows: a. Roll attitude is read from the ball-driven movable index (roll bug) referenced to the calibrated bezel ring around the ball, with respect to S/C navigation axes only. b. Pitch and yaw are read directly from the calibrated surface of the ball, with respect to either the S/C body axes index or the navigation axes index. Two 30° red circular areas on the ball surface denote attitude regions in which G&N IMU gimbal lock or excessive SCS AGCU error can occur.	SCS - GROUP 1 AC 1 GROUP 1 AC 2 (MDC-25)	A-C bus No. 1 or No. 2 (via SCS display/AGAA ECA)		Total attitude indicator calibration Pitch 0° - 360° (ball longitude) Yaw 270° - 0° - 90° (ball latitude) Roll 0° - 360° (bezel ring) Total attitude indicator direction of positive (+) rotation Axis of rotation (other two axes fixed at 0°) Ball Rotation pitch - up from top to bottom yaw - right from right to left roll - right counterclockwise Total attitude indication follows attitude deviations only in the following situations: a. When G&N system supplies inputs b. When [CSS + translation control CW + .05g + (ATTITUDE IMPULSE-ENABLE) + (SCS attitude mode) + (pitch disabled + yaw disabled + both roll disabled)] (BUR in any axis)'. (MTVC): (FDAI align)'. Attitude error indicator calibration (full-scale deflection) <table border="1"> <thead> <tr> <th>Modes</th> <th>Roll</th> <th>Pitch</th> <th>Yaw</th> </tr> </thead> <tbody> <tr> <td>Monitor (G&N)</td> <td>±25°</td> <td>±15°</td> <td>±15°</td> </tr> <tr> <td>G&N entry SCS entry</td> <td>±25°</td> <td>±5°</td> <td>±5°</td> </tr> <tr> <td>All other modes</td> <td>±5°</td> <td>±5°</td> <td>±5°</td> </tr> </tbody> </table>	Modes	Roll	Pitch	Yaw	Monitor (G&N)	±25°	±15°	±15°	G&N entry SCS entry	±25°	±5°	±5°	All other modes	±5°	±5°	±5°
Modes	Roll	Pitch	Yaw																			
Monitor (G&N)	±25°	±15°	±15°																			
G&N entry SCS entry	±25°	±5°	±5°																			
All other modes	±5°	±5°	±5°																			
	Attitude error indication	S/C attitude errors are displayed by three fly-to-type needles mounted on the bezel ring around the attitude ball, with the top, right, and bottom needles corresponding to roll, pitch, and yaw, respectively. The readouts denote one of the following: a. Difference between present S/C attitude and the S/C reference attitude stored in either the G&N ICDUs or the SCS AGCU. The readouts are always referenced to S/C body axes, except during G&N-controlled																				

MAIN DISPLAY CONSOLE - PANEL 4

SM2A-03-SC012
APOLLO OPERATIONS HANDBOOK

CONTROLS AND DISPLAYS

Symbol	Name and Location	Function	Circuit Breaker	Power Source	Telemetry Code No. and Identity	Remarks																																												
000000 (cont)		<p>entry when the roll error needle is referenced to the S/C navigation axis. The pitch and yaw error needles will be zero after 0.05 g switching in a CHN entry mode, and there will be no attitude error displayed after 0.05 g in an SCS entry mode.</p> <p>b. Difference between the present S/C reference attitude stored in the SCS AGCU and a desired attitude dialed into the attitude set/gimbal position display, with the ATTITUDE SET function engaged. Dialed in and stored attitudes are referenced to S/C navigation axes, with the difference angles inverted to body axes for display by the error needles.</p>	SCS-GROUP 1 AC 1 GROUP 1 AC 2 (MDC-25)	A-C bus No. 1 or No. 2 (via SCS display/ AGAA ECA		<p>Attitude error indicator deflection for positive (+) rotational input commands</p> <table border="1" style="margin-left: auto; margin-right: auto;"> <tr> <td>Axis of Rotation (positive command)</td> <td>Indicator Deflection from Zero (center)</td> </tr> <tr> <td>roll</td> <td>left</td> </tr> <tr> <td>pitch</td> <td>up</td> </tr> <tr> <td>yaw</td> <td>left</td> </tr> </table>	Axis of Rotation (positive command)	Indicator Deflection from Zero (center)	roll	left	pitch	up	yaw	left																																				
Axis of Rotation (positive command)	Indicator Deflection from Zero (center)																																																	
roll	left																																																	
pitch	up																																																	
yaw	left																																																	
	Angular rate indication	<p>S/C angular velocities are displayed by three fly-to-type indicators mounted above, to the right of, and below the attitude ball corresponding to roll, pitch, and yaw, respectively. The readouts are always referenced to S/C body axes except during atmospheric entry (after 0.05 g) when the yaw rate indicator is referenced to the S/C stability axis. Inputs to the indicators are supplied by either the SCS rate gyros (normal) or the SCS BMAGs (backup).</p>				<p>Angular rate indicator calibration (full-scale deflection)</p> <table border="1" style="margin-left: auto; margin-right: auto;"> <tr> <td>Modes</td> <td>Roll</td> <td>Pitch</td> <td>Yaw</td> </tr> <tr> <td>Monitor (G&N)</td> <td>±25°/sec</td> <td>±5°/sec</td> <td>±5°/sec</td> </tr> <tr> <td>G&N entry</td> <td></td> <td></td> <td></td> </tr> <tr> <td>SCS entry</td> <td></td> <td></td> <td></td> </tr> <tr> <td>G&N delta V</td> <td>±5°/sec</td> <td>±5°/sec</td> <td>±5°/sec</td> </tr> <tr> <td>SCS delta V</td> <td></td> <td></td> <td></td> </tr> <tr> <td>G&N att cont</td> <td></td> <td></td> <td></td> </tr> <tr> <td>SCS att cont</td> <td>±1°/sec</td> <td>±1°/sec</td> <td>±1°/sec</td> </tr> <tr> <td>SCS lcl vert</td> <td></td> <td></td> <td></td> </tr> </table> <p>Angular rate indicator deflection for positive (+) rotational input commands</p> <table border="1" style="margin-left: auto; margin-right: auto;"> <tr> <td>Axis of Rotation (positive command)</td> <td>Indicator Deflection from Zero (center)</td> </tr> <tr> <td>roll</td> <td>left</td> </tr> <tr> <td>pitch</td> <td>up</td> </tr> <tr> <td>yaw</td> <td>left</td> </tr> </table>	Modes	Roll	Pitch	Yaw	Monitor (G&N)	±25°/sec	±5°/sec	±5°/sec	G&N entry				SCS entry				G&N delta V	±5°/sec	±5°/sec	±5°/sec	SCS delta V				G&N att cont				SCS att cont	±1°/sec	±1°/sec	±1°/sec	SCS lcl vert				Axis of Rotation (positive command)	Indicator Deflection from Zero (center)	roll	left	pitch	up	yaw	left
Modes	Roll	Pitch	Yaw																																															
Monitor (G&N)	±25°/sec	±5°/sec	±5°/sec																																															
G&N entry																																																		
SCS entry																																																		
G&N delta V	±5°/sec	±5°/sec	±5°/sec																																															
SCS delta V																																																		
G&N att cont																																																		
SCS att cont	±1°/sec	±1°/sec	±1°/sec																																															
SCS lcl vert																																																		
Axis of Rotation (positive command)	Indicator Deflection from Zero (center)																																																	
roll	left																																																	
pitch	up																																																	
yaw	left																																																	

MAIN DISPLAY CONSOLE - PANEL 4

SM2A-03-SC012
 APOLLO OPERATIONS HANDBOOK

CONTROLS AND DISPLAYS

Item No.	Name and Position	Function	Circuit Breaker	Power Source	Telemetry Code No. and Identity	Remarks
MM-5	Digital event timer	The event timer provides the crew with a means of monitoring and timing events. Indications from 00 minutes and 00 seconds (00-00) to 59 minutes and 59 seconds (59-59) are obtainable in a countup or countdown mode. In a countup mode, when 59-59 is recorded, the counter will proceed to 00-00 and continue to count up. In a countdown mode, continuous counting is also available.	EVENT TIMER MNA MNB (MDC-25)	D-C main buses A and B	None	The event timer is a reference system only and is automatically react to zero when an abort is automatically or manually initiated. The event timer starts automatically when lift-off occurs.
	L/V RATE light	Illuminates red to indicate that the permissible angular rates in any of pitch, roll, or yaw axes have been exceeded. Rates in excess of 20 degrees/second in roll and 5 degrees/second in pitch or yaw illuminate the rate light.	EDS-1, 3 BAT A BAT B (MDC-25)	Battery buses A and B when the EDS POWER switch (MDC-24) is ON.	BS0020X (Launch vehicle rate excessive A)	When used in conjunction with the angle-of-attack display and the attitude error reading of the FDAI, will indicate the necessity for manual abort initiation. The light also illuminates when an auto abort is initiated because of excessive rates.
	L/V GUID light	Illuminates red to indicate platform failure in the L/V guidance system (loss of attitude control).			BS0016X (Launch vehicle guidance fail A)	
	L/V ENGINES lights					
	Light No. 1	Illuminates to indicate S-IB or S-IVB engine No. 1 operating below 90 percent of total thrust capability.			BS0030X (Engine No. 1 out A)	All engine lights are yellow. The lights are used to indicate staging and the necessity for initiating a manual abort when two S-IB engines are operating below 90 percent of thrust. When enabled in the auto abort mode, an auto abort will be initiated with two engines below 90 percent of thrust.
	Light No. 2	Illuminates to indicate S-IB engine No. 2 operating below 90 percent of total thrust capability.			BS0032X (Engine No. 2 out A)	
	Light No. 3	Illuminates to indicate S-IB engine No. 3 operating below 90 percent of total thrust capability.			BS0034X (Engine No. 3 out A)	
	Light No. 4	Illuminates to indicate S-IB engine No. 4 operating below 90 percent of total thrust capability.			BS0036X (Engine No. 3 out A)	

MAIN DISPLAY CONSOLE - PANEL A

SM2A-03-SC012
APOLLO OPERATIONS HANDBOOK

CONTROLS AND DISPLAYS

Location	Symbol Description	Function	Circuit Breaker	Power Source	Telemetry Code No. and Identity	Remarks
MDC-3 (Cont)	Light No. 5	Illuminates to indicate S-IE engine No. 5 operating below 90 percent of total thrust capability.	EDS-1, 3 BAT A BAT B (MDC-25)	Battery buses A and B when the EDS POWER switch (MDC-24) is ON.	BS0038X (Engine No. 5 out A)	The LIFT OFF/NO AUTO ABORT switch/light combination should be pressed if the LIFT OFF light does not illuminate at lift off. (Refer to malfunction procedures.)
	Light No. 6	Illuminates to indicate S-IE engine No. 6 operating below 90 percent of total thrust capability.				
	Light No. 7	Illuminates to indicate S-IB engine No. 7 operating below 90 percent of total thrust capability.				
	Light No. 8	Illuminates to indicate S-IB engine No. 8 operating below 90 percent of total thrust capability.				
	LIFT-OFF and NO AUTO ABORT lights	White light illuminates at lift-off.			BS0060X BS0061X (Lift-off signal A & B)	The relay controlling the white light is reset 5 seconds after lift-off by a timer in the L/V instrumentation unit
	NO AUTO ABORT light	Switch-light will illuminate red at lift-off if either of the LV-EDS auto abort systems has not been automatically enabled.			None	The astronaut will press the switch-light which will electrically enable the LV-EDS automatic abort system. If the light still does not go out, it indicates that one or both of the dual redundant EDS systems is not enabled. In this event, the crew must be prepared to initiate a manual abort, if necessary.
	LES MOTOR FIRE switch	a. Backup switch to fire the launch escape motor. b. Backup switch to jettison the LES tower in the event the jettison motor failed to ignite	MASTER EVENTS SEQ CONT - A ARM B BAT A BAT B (MDC-22)	Battery buses A and B	CD0101X LE/Pc motor fire initiate A CD0102X LE/Pc motor fire initiate B	The LES motor is normally (automatically) fired approximately 0.1 second by the MESC following abort initiation. It may be used for a backup for the jettison motor only after normal means of TWR jettison has failed. This is assuming that the TWR separation nuts are fractured.

MAIN DISPLAY CONSOLE - PANEL 5 -

SM2A-03-SC012
APOLLO OPERATIONS HANDBOOK

CONTROLS AND DISPLAYS

Location	Name and Position	Function	Circuit Breaker	Power Source	Telemetry Code No. and Identity	Remarks
MDC-5 (Cont)	CANARD DEPLOY switch	Backup switch to deploy the canard when it does not deploy automatically during an abort.	MASTER EVENTS SEQ CONT - A ARM B BAT A BAT B (MDC-22)	Battery buses A and B	CD0120X CDC121X Canard deploy A and B	Push-type switch. The canard will normally (automatically) deploy 11 seconds after a LES abort initiation.
	ADAP SEP switch	a. Switch for normal CSM/S-IVB separation after the ascent phase of the mission. (Refer to adapter separation mechanism in section 2.) b. Backup switch for CSM/S-IVB separation if it does not separate automatically during an SPS abort. (Refer to SPS abort procedures.)			CD0125X Adapter/SM separate initiate A CD0126X Adapter/SM separate initiate B	Push-type switch to separate the adapter when an SPS abort cannot be initiated with the commanders translational control. SPS ullage and firing would be manual functions.
	APEX COVER JETT switch	Backup switch to jettison the C/M apex cover.	ELS A - BAT A - FLOAT BAG 3 ELS B - BAT B (MDC-25)		CD0230X Forward heat shield jettison A CD0231X Forward heat shield jettison B	Push-type switch to jettison the C/M apex cover if the automatic system fails during an abort or earth landing after a normal mission.
	DROGUE DEPLOY switch	Backup switch to deploy the drogue parachutes.			CE0001X Drogue deploy relay close A CE0002X Drogue deploy relay close B	Push-type switch. The drogue parachutes will normally (automatically) deploy 2 seconds after the 24,000 foot baro switch closes.
	MAIN DEPLOY switch	Backup switch to deploy the main parachutes.			CE0003X Main parachute deploy -drogue release relay A CE0004X Main parachute deploy -drogue release relay B	Push-type switch. The main parachutes will normally (automatically) deploy when the 10,000 foot baro switch closes during descent. The switch is also used to initiate manual deployment of the main parachutes during aborts initiated prior to 61 seconds after lift-off.

MAIN DISPLAY CONSOLE - PANEL 5

SM2A-03-SC012
 APOLLO OPERATIONS HANDBOOK

CONTROLS AND DISPLAYS

Item No.	Control Location	Function	Circuit Breaker	Power Source	Telemetry Code No. and Identity	Remarks
MDC-5 (MDC-5)	Backup switches lock control LOCK UNLOCK	Locks the backup switches to prevent inadvertent operation. Unlocks and enables the backup switches to be pushed manually.	N/A	N/A	None	
MDC-6	ATTITUDE SET group: ROLL, PITCH, YAW thumbwheels and indicators	Enables manual insertion of a desired attitude reference into the SCS, either for AGCU alignment or for a commanded S/C attitude maneuver reference during SCS flight modes. Enable manual selection and display of desired roll, pitch, and yaw attitude settings referenced to S/C navigation axes.	SCS— GROUP 1 AC 1 GROUP 1 AC 2 (MDC-25)	A-C bus No. 1 or No. 2	None	Yaw thumbwheel is marked with a stripe, denoting yaw angles of 75° and 285°, as a caution against dialing in settings at which G&N IMU gimbal lock or excessive SCS AGCU error can occur. Indicators provide digital type displays.
	FDAI ALIGN switch	a. Couples manually selected (dialed in) attitude settings into the SCS for alignment of the present S/C reference attitude stored in the AGCU to the desired reference attitude. b. Decouples normal SCS BMAG inputs to the AGCU and the BMAGS are free gyros until the switch is released. c. Aligns the FDAI attitude ball to the dialed-in attitude, referenced to S/C navigation axes, in SCS flight modes only.	SCS— GROUP 1 MN A MN B (MDC-25)	D-C main bus A or B		Momentary-contact pushbutton switch which must be held engaged until alignment is completed. SCS AGCU alignment slew rates roll — 20°/sec pitch — 5°/sec yaw — 5°/sec Perform the FDAI/AGCU align function.

MAIN DISPLAY CONSOLE — PANELS 5 AND 6

SM2A-03-SC012
APOLLO OPERATIONS HANDBOOK

CONTROLS AND DISPLAYS

Location	Name and Position	Function	Circuit Breaker	Power Source	Telemetry Code No. and Identity	Remarks
MDC-6 (Cont)	ATT SET switch On (up)	a. Couples the attitude difference angles to the FDAI attitude error indicators, referenced to S/C body axes. b. Decouples normal SCS BMAG inputs to the FDAI attitude error indicators. (BMAGs continue to operate normally otherwise.)	SCS— GROUP 1 MN A MN B (MDC-25)	D-C main bus A or B	None	The attitude set function which enables S/C maneuver to a desired (dialed in) attitude is applicable to SCS flight modes only. The desired attitude is achieved by flying out the attitude error needles, using the rotation control.
	OFF	Inhibits the attitude set function.				
	GIMBAL POSITION group	Provides display and manual control of gimbaled SPS engine thrust axis orientation with respect to S/C body axes.	SCS GROUP 1 AC 1 & AC 2 GROUP 2 AC 1 & AC 2 (MDC-25)	A-C bus No. 1 or No. 2		Yaw indicator and thumbwheel are calibrated in 0.5° increments from -3° to +13°. Center reading of +4° corresponds to yaw gimbal position null, due to engine offset for S/C CG.
	YAW, PITCH indicators	Provide display of engine gimbal position readouts with respect to S/C yaw and pitch (body) axes, respectively.		(via yaw and pitch ECAs)	CH3135V (pitch GPI amp demod out)	Yaw indicator and thumbwheel are calibrated in 0.5° increments from -9° to +9°. Center reading of 0° corresponds to pitch gimbal position null.
	YAW, PITCH thumbwheels	Thumbwheel displacement in a positive direction will provide a relative positive gimbal position indicator display indicating nozzle positioning for a positive axis displacement when thrust is initiated.		(via display/AGAA ECA)	None	Trimming of gimbal positions by use of the thumbwheels is possible when performing MTVC. Group 2 circuit provides power to MTVC circuits.

MAIN DISPLAY CONSOLE—PANEL 6

SM2A-03-SC012
APOLLO OPERATIONS HANDBOOK

CONTROLS AND DISPLAYS

Location	Name and Position	Function	Circuit Breaker	Power Source	Telemetry Code No. and Identity	Remarks
MDC-7	DIRECT ULLAGE switch	Provides backup capability for initiating ullage (+X translation) prior to SPS burns. a. Energizes injector valve direct coils of four +X SM RCS engines. b. Disengages automatic attitude hold capability in pitch and yaw axes.	SCS— DIRECT CONT MN A MN B (MDC-25)	D-C main bus A or B	None	Momentary-contact pushbutton switch which must be held engaged until ullage is completed. Translation control provides normal capability for initiating ullage.
	THRUST ON switch light	a. Switch actuation applies manual SPS engine thrust-on logic command to SCS electronics which energizes coils of SPS engine helium isolation valves (if SPS He switch on MDC-20 is in AUTO position) and pilot control valves. b. Switch face illumination indicates application of SPS engine thrust-on signal from G&N system or THRUST ON switch to SCS electronics. Light is extinguished when SPS engine thrust-off signal from G&N system, ΔV REMAINING counter, or flight combustion stability monitor is detected in SCS electronics.	SCS— GROUP 1 MN A MN B (MDC-25)		CH4320X (SPS solenoid control valve energized) CH4321X (SPS solenoid control valve energized)	Pushbutton momentary-contact-type switch. Provides normal SPS engine ignition control in SCS ΔV mode, backup control in G&N ΔV mode. FDAI BRIGHTNESS control must be on to provide switch face illumination. Switch face does not indicate application of thrust on/off commands via the NORMAL/OFF/DIRECT ON switch (MDC-7).
	NORMAL/OFF/DIRECT ON switch	Enables circuit capability for energizing of SPS fuel and oxidizer control solenoids by either AGC or THRUST ON switch stimuli, providing all other logic is complied with. Provides capability to remove power from the four SPS engine pilot control valve solenoids directly, thereby, terminating thrust.	SCS— DIRECT CONT MN A MN B (MDC-25)		None	Switch is a three-position lever-lock toggle switch. To set the switch in the NORMAL position or the DIRECT ON position, pull the lever out past the lever lock (shoulder stop) and move the lever up and down, respectively. The in-flight position of the switch is the OFF (center) position. DIRECT ON position provides capability of bypassing thrust on logic circuit and initiating SPS engine firing directly.

MAIN DISPLAY CONSOLE—PANEL 7

SM2A-03-SC012
 APOLLO OPERATIONS HANDBOOK

CONTROLS AND DISPLAYS

Location	Name and Position	Function	Circuit Breaker	Power Source	Telemetry Code No. and Identity	Remarks
MDC-7 (Cont)	DIRECT ON	Connects 128 vdc direct from circuit breaker to SPS pilot control valve solenoids. Energizes SPS driver relays K1 and K2, which provide power application to helium isolation valves and PUGS.	SCS DIRECT CONT MN A MN B (MDC-25)	D-C main buses A or B	None	The DIRECT ON switch overrides FCSM.
	ΔV SET switch Upper hardstop (uppermost position) Upper softstop (upper middle position) Center position Lower softstop (lower middle position) Lower hardstop (bottommost position)	Enables desired ΔV to be placed on ΔV REMAINING display. Enables increase of ΔV REMAINING display at rate of 64 digits per sec. Enables increase of ΔV REMAINING display at rate of 2 digits per sec. Provides inhibit to ΔV counter after TVC #1 power switch is turned on until a XX ullage is initiated, except when open. Enables decrease of ΔV REMAINING display at rate of 2 digits/per sec. Enables decrease of ΔV REMAINING display at rate of 64 digits/per sec.	SCS GROUP 1 AC 1 GROUP 1 AC 2 (MDC-25)	±15 vdc from DISP/AGAA ECA	CH3186V ΔV remaining	The ΔV set switch is a five-position switch with two + (ΔV increase) positions, two - (ΔV decrease) positions, and an OFF (center) position.
	ΔV REMAINING indicator	Displays ΔV magnitude and/or ΔV REMAINING in feet per second.		DISP/AGAA ECA		When the SPS engine is thrusting, the ΔV REMAINING indicator receives a signal from the SCS X-axis accelerometer, driving the indicator toward zero. The ΔV REMAINING display is activated when the TVC 1 POWER switch is set to either AC 1 or AC 2 position and the integrator circuit threshold of $5 \times 10^{-4} g$ has been attained while performing a +X (only) translation maneuver. Acceleration sensing will begin at ullage or +X RCS translation initiation. An indicating range from -1000 (99, 000) to 12, 999 feet/second (f/s) is provided at an accuracy of ±1.5 percent or 0.75 f/s, whichever is greater.

SM2A-03-SC012
APOLLO OPERATIONS HANDBOOK

CONTROLS AND DISPLAYS

Location	Name and Position	Function	Circuit Breaker	Power Source	Telemetry Code No. and Identity	Remarks
MDC-7 (Cont)			SCS GROUP 1 AC 1 GROUP 2 AC 2 (MDC-25)	DISP /AGAA ECA	CH3816 V ΔV remaining	When thrusting in SCS ΔV mode, thrust-off signal is terminated when ΔV REMAINING display reaches 00000. The thrust-off signal is inhibited by the AGC when operating in G&N ΔV mode. No inhibit is provided by the ΔV REMAINING display circuits when in the G&N ΔV mode.
MDC-8	DIRECT RCS switch	Provides capability for direct manual control of S/M or C/M-RS engines.	SCS DIRECT CONT MIN A MIN B (MDC-25)	D-C main buses A or B	None	DIRECT RCS position provides the crew with direct control of the S/M or C/M RCS engines for rotational maneuver commands. Direct control is achieved by positioning the rotation control to engage the direct switches for the desired axis change. Direct switches are engaged at 1 ± 0.5 degree from any hard stop. All SCS electronics are bypassed during this function.
	DIRECT RCS (up)	Applies d-c power to rotation control, enabling direct manual control of S/M or C/M-RCS engines.				
	OFF	Removes manual direct control capability of the S/M or C/M-RCS engines.				
	LIMIT CYCLE switch	Provides manual capability to retain or inhibit SCS pseudo rate (limit cycling) during RCS engine operation.	None	None		The primary purpose of the LIMIT CYCLE switch is to provide the crew with the capability of manually inhibiting the pseudo rate circuit operation during maneuvering and the entry phase of the mission. For fuel conservation, the switch should be set to LIMIT CYCLE position when holding attitude with the S/M RCS. The LIMIT CYCLE position function is disabled when the breakout switches in the rotation control are actuated, or when manual translation is commanded.
	LIMIT CYCLE	Allows normal operation of SCS pseudo rate circuit, providing limit cycling of RCS engines during attitude control modes.				
	OFF	Prevents operation of SCS pseudo rate circuit in pitch, yaw, and roll ECAs.				
	ATT DEADBAND switch	Enables selection of attitude deadband control sensitivity.	SCS GROUP 1 MN A MN B (MDC-25)	D-C main buses A or B		This switch selects a deadband in SCS that prevents attitude correction signals from being applied to the RCS until the attitude error exceeds the selected deadband.
	MAX	Selects maximum attitude deadband of $\pm 4.2^\circ$.				

SM2A-03-SC012
APOLLO OPERATIONS HANDBOOK

CONTROLS AND DISPLAYS

Location	Name and Position	Function	Circuit Breaker	Power Source	Telemetry Code No. and Identity	Remarks
MDC-# (Cont)	MIN	Selects minimum deadband of $\pm 0.2^\circ$.	SCS - GROUP 1 MN A MN B (MDC-25)	D-C main buses A or B	None	Minimum deadband is used only when tight attitude control is required; e.g., during navigational sightings and prior to and during ΔV maneuvers. No power to this switch during SCS or G&N entry modes; therefore, minimum-deadband cannot be selected during entry.
	RATE GYRO switches	Provide manual capability to place the roll, pitch, or yaw BMAG in the backup rate mode of operation.				These switches place any or all of the BMAGs in backup rate mode of operation so that they may be used in place of the rate gyros to provide spacecraft rate stabilization. In addition, with any one of the RATE GYRO switches in the BMAG position and any one of the following selected, the remaining two BMAGs will automatically assume the backup rate mode of operation: .05G ENTRY switch to .05G ENTRY position, monitor mode selected, minimum control mode selected, minimum impulse attitude control mode engaged, G&N entry mode selected, either rotation control out of neutral position, SCS local vertical, or one SCS channel disabled while in SCS attitude control mode.
	ROLL	Allows normal BMAG and rate gyro operation.				
	NORMAL	Enables BMAG rate mode of operation removing rate gyro signal from rate indicators, etc.				
	BMAG					
	PITCH					
	NORMAL	Allows normal BMAG and rate gyro operation.				
	BMAG	Enables BMAG rate mode of operation, removing rate gyro signal from rate indicators, etc.				
	YAW					
	NORMAL	Allows normal BMAG and rate gyro operation.				
	BMAG	Enables BMAG rate mode of operation, removing rate gyro signal from rate indicators, etc.				
	.05G ENTRY switch	Enables the SCS for atmospheric flight during entry and after 0.05g				When in an SCS mode, the attitude reference capability is lost when any one of the BMAGs is in backup rate mode. Attitude information is maintained if operating in a G&N mode. .05G ENTRY switch is effective only when a G&N or SCS entry mode is selected.
	.05G ENTRY	Removes attitude error signals from pitch and yaw channels in G&N mode and pitch, yaw, and roll channels in SCS modes.				After .05G ENTRY position is selected, placing any one of the BMAGs in backup rate mode will automatically place all BMAGs in backup rate mode configuration. This

MAIN DISPLAY CONSOLE - PANEL 8

SM2A-03-SC012
 APOLLO OPERATIONS HANDBOOK

CONTROLS AND DISPLAYS

Indicator	Name and Position	Function	Circuit Breaker	Power Source	Telemetry Code No. and Identity	Remarks
MDC # (MDC)	OFF	b. Increases the rate deadband from 0.2° per sec to 2° per sec. c. Energizes a circuit which couples a component of the roll rate signal into the yaw channel. Allows normal system operation.	SCS-GROUP 1 MN A MN B (MDC-25)	D-C main buses A or B	None	results in loss of FDAI total attitude display; otherwise, total attitude display is provided. During entry the S/C is maneuvered about the stability roll axis rather than the body roll axis. Consequently the yaw rate gyro generates an undesirable rate signal. By coupling a component of the roll signal into the yaw channel, the undesirable signal is cancelled.
	LCL VERT switch	Enables SCS for local vertical mode operation.			CH1103X (SCS local vertical mode control)	The local vertical mode maintains the S/C attitude with respect to the earth's local vertical. With local vertical mode engaged, an orbit rate signal equivalent to pitch rate of approximately 4.1° per minute is applied to the pitch BMAG torque motor. This figure is for a 100 NM earth orbit. FDAI total attitude is referenced to local vertical. Attitude error values represent deviation from selected local vertical attitude.
	LCL VERT (up)	Selects SCS local vertical mode when used in conjunction with G&N/SCS switch and ATTITUDE/MONITOR/ENTRY switch.				If the S/C is maneuvered after local vertical mode is selected, the 4.1° per minute orbit rate signal previously applied only to the pitch gyro will be applied to all three gyros. This is accomplished by summing and resolving the new stepper motor position outputs with the orbital rate signal in the nav-to-body transformation circuits.
	OFF	Disengages local vertical mode.				This switch works in conjunction with the G&N/SCS switch and the ATTITUDE/MONITOR/ENTRY switch. MTVC is actuated only when the ΔV switch is in the ΔV position and when the translation control is rotated CW. MTVC is independent of G&N/SCS switch.
	ΔV switch	Enables SCS for G&N or SCS ΔV mode operation or MTVC. Applies a signal to the SCS electronics enabling the system for ΔV modes of operation and also enables manual thrust vector control (MTVC), of the translation control SW switch is closed.			CH0100X (G&N ΔV mode) CH1100X (5c ΔV mode) CH1104X (MTVC mode)	In the ΔV position, DC power is applied to the FCSM-G&N and FCSM-SCS switches (MDC-2).

MAIN DISPLAY CONSOLE - PANEL #

SM2A-03-SC012
APOLLO OPERATIONS HANDBOOK

CONTROLS AND DISPLAYS

Number	Name and Position	Function	Circuit Breaker	Power Source	Telemetry Code No. and Identify	Remarks																					
SCS-03 (C-01)	OFF	Inhibits ΔV and MTC modes of operation and permits operation of the SCS in other modes.	SCS- GROUP 1 MN A MN B (MDC-25)	D-C main buses A or B	CH0101X (G&N attitude control mode control)	The G&N/SCS switch works in conjunction with the other flight control mode switches. When the switch is positioned to G&N or SCS position, ΔV maneuvers and attitude control of the S/C is accomplished by the selected system.																					
	G&N (up)	Enables G&N control for the following modes: attitude control, entry, and ΔV maneuvers.																									
	SCS	Enables SCS control for the following modes: attitude control, monitor, local vertical, entry, and ΔV maneuvers.																									
ATTITUDE MONITOR/ENTRY switch	ATTITUDE MONITOR/ENTRY switch	Selects one of the following basic flight control modes: attitude control, monitor, or entry.	SCS- A&C ROLL MN A MN B and GROUP 1 MN A and MN B (MDC-25)	None	CH0103X (Monitor mode control) CH0102X (G&N entry mode control) CH1102X (SCS entry mode)	The ATTITUDE/MONITOR/ENTRY switch works in conjunction with the G&N/SCS switch, the ΔV switch, and the LCL VERT switch to enable crew selection of the various flight control modes. For details of the switch positions required to select the flight control modes, refer to Normal/Backup Procedures. In the attitude or monitor modes, the rate deadband for all axes is 0.2 /sec. The rate deadband for all axes in entry mode is 2.0°/sec. This applies to either entry mode: SCS or G&N. Monitor position selects the G&N monitor mode independent of other mode switches.																					
	ATTITUDE MONITOR	Enables monitor mode. (Refer to Remarks.)																									
	ENTRY	Enables G&N or SCS entry mode. (Refer to Remarks.)																									
SCS CHANNEL switches	SCS CHANNEL switches	Provides capability to manually deactivate the RCS engines.	SCS- A&C ROLL MN A MN B and GROUP 1 MN A and MN B (MDC-25)	None	None	These switches are used to disable the RCS engines in the event of a malfunction or whenever it may be operationally desirable; e.g., S/C three-axis free drift for purposes of propellant conservation. Direct control of the RCS is available, using the DIRECT MODE switch and the rotation control. Maneuver function - engine activation.																					
	A&C ROLL	Applies +28 vdc to the normal injector valve solenoids and solenoid driver electronic, allowing normal RCS engine operation.																									
	On (up)	Removes +28 vdc from the normal injector valve solenoids and the driver solenoid amplifier. Inhibits normal manual rotation control capability and SCS automatic control of RCS engine operation.																									
	OFF					<table border="1"> <thead> <tr> <th>Switch</th> <th>Function</th> <th>S/M RCS Engine</th> </tr> </thead> <tbody> <tr> <td>A&C ROLL</td> <td>Roll right</td> <td>A13, C15</td> </tr> <tr> <td>A&C ROLL</td> <td>Roll left</td> <td>A16, C14</td> </tr> <tr> <td>B&D ROLL</td> <td>Roll right</td> <td>B9, D11</td> </tr> <tr> <td>B&D ROLL</td> <td>Roll left</td> <td>B12, D10</td> </tr> <tr> <td>PITCH</td> <td>Pitch up</td> <td>A3, C1</td> </tr> <tr> <td>PITCH</td> <td>Pitch down</td> <td>A2, C4</td> </tr> </tbody> </table>	Switch	Function	S/M RCS Engine	A&C ROLL	Roll right	A13, C15	A&C ROLL	Roll left	A16, C14	B&D ROLL	Roll right	B9, D11	B&D ROLL	Roll left	B12, D10	PITCH	Pitch up	A3, C1	PITCH	Pitch down	A2, C4
Switch	Function	S/M RCS Engine																									
A&C ROLL	Roll right	A13, C15																									
A&C ROLL	Roll left	A16, C14																									
B&D ROLL	Roll right	B9, D11																									
B&D ROLL	Roll left	B12, D10																									
PITCH	Pitch up	A3, C1																									
PITCH	Pitch down	A2, C4																									

APOLLO OPERATIONS HANDBOOK

CONTROLS AND DISPLAYS

Item No.	Name and Position	Function	Circuit Breaker	Power Source	Telemetry Code No. and Identity	Remarks	
						Switch	Function
M104 - 10 (10 only)	B&D ROLL On (up)	Applies +28 vdc to the normal injector valve solenoids and solenoid driver electronics, allowing normal RCS engine operation.	SCS- B&D ROLL MN A MN B and GROUP 1 MN A and MN B (MDC-25)	D-C main buses A or B	None	Switch	S/M RCS Engine B7, D5 B6, D8
		Removes +28 vdc from the normal injector valve solenoids and the driver solenoid amplifier. Inhibits normal manual rotation control capability and SCS automatic control of RCS engine operation.				Function	Roll right Roll left Pitch up Pitch down Yaw right Yaw left
	PITCH On (up)	Applies +28 vdc to the normal injector valve solenoids and solenoid driver electronics, allowing normal RCS engine operation.	SCS- PITCH MN A MN B and GROUP 1 MN A and MN B (MDC-25)			Switch	C/M RCS Engine A9, B11 A12, B10 A1, B3 A2, B4 A5, B7 A8, B6
		Removes +28 vdc from the normal injector valve solenoids and the driver solenoid amplifier. Inhibits normal manual rotation control capability and SCS automatic control of RCS engine operation.				Function	Roll right Roll left Pitch up Pitch down Yaw right Yaw left
	YAW On (up)	Applies +28 vdc to the normal injector valve solenoids and solenoid driver electronics, allowing normal RCS engine operation.	SCS- MN A MN B and GROUP 1 MN A and MN B (MDC-25)			Switch	
	OFF	Removes +28 vdc from the normal injector valve solenoids and the driver solenoid amplifier. Inhibits normal manual rotation control capability and SCS automatic control of RCS engine operation.				Function	

SM2A-03-SC012
 APOLLO OPERATIONS HANDBOOK

CONTROLS AND DISPLAYS

Location	Name and Position	Function	Circuit Breaker	Power Source	Telemetry Code No. and Identity	Remarks
MDC-4 (E/M)	ELS LOGIC switch Up	Connects 24 vdc to the ELS logic arm circuitry. The circuitry is automatically armed during an LES abort if the MAIN DEPLOY-AUTO/MAIN switch (MDC-16) is in the AUTO position.	ELS - A BAT A - FLOAT BAG ELS - B BAT B (MDC-25)	Battery buses A and E	None	The logic switch is positioned up during entry or after an SPS abort to arm the ELS logic circuitry. This circuitry is armed automatically on LES aborts. The ELS is controlled by baroswitch closure and time-delay relays after being armed. The switch should never be positioned up under 42,000 feet except as backup during an LES abort. The LES tower, apex cover and parachutes might be jettisoned.
	DIGITAL EVENT TIMER RESOURCES	Disconnects 24 vdc from ELS logic circuitry.	EVENT TIMER MN A MN J (MDC-26)	D-C main buses A and E		The event timer is automatically reset to zero and starts counting up when an abort is automatically or manually initiated. The switch is momentary on towards the PESET position and maintain on in the other two positions.
	PESET/UP/DOWN switch	Resets the event timer (MDC-5) to zero.				
	RESET	Completes circuitry for the event timer to time up				
	UP	Completes circuitry for the event timer to time down.				
	DOWN					
	START/STOP switch					
	START	Starts the event timer.				
	Center	No function				
	STOP	Stops the event timer.				
	MIN switch					
	TENS	Runs the MIN indicating drums in tens				
	Center	No function.				
	UNITS	Runs the second MIN indicating drum in units.				

MADE UP BY CONSOLE - PAGE 4

Mission _____

Rev. D 0

Change Date _____

Page 4-11

APOLLO OPERATIONS HANDBOOK

CONTROLS AND DISPLAYS

Location	Name and Position	Function	Circuit Breaker	Power Source	Telemetry Code No. and Identity	Remarks
MDC-8 (Panel)	SEC switch		EVENT TIMER MN A MN B (MDC-25)	D-C main buses A and B	None	The attenuators will be unlocked by a breakout (approximately 20gs) upon landing.
	TENS	Runs the SEC indicating drums of the event timer in tens.				
	Center	No function.				
	UNITS	Runs the second SEC indicating drum in units.				
	COUCH UNLOCK switch		COUCH ATTEN MN A MN B FLOOD- LIGHTS (MDC-25)			
	UNLOCK	Inoperative				
	Down position					
	CM PROP JETT switches		RCS-- C/M-S/M TRANSFER MN A MN B (MDC-25)			Two-position toggle switch. Switch must be in up position before power is available to the DUMP switch, PURGE switch, RCS HTRS switch, and circuitry controlling automatic transfer of engine firing commands from S/M RCS to C/M RCS.
	LOGIC switch					
	On (up)	Applies power to DUMP switch on MDC-8. Applies power to the 0 to 61-second time delay (from lift-off) and the 18-second time delay after the abort is initiated. Applies power to relay contact points that are closed upon receipt of an abort signal (from 0 to tower jettison) which applies power automatically to RCS transfer motors. Applies power to the C/M RCS engine manual coils (excluding +P) manual coils when the DUMP switch is placed to the on position.				
	OFF	Applies power to the C/M RCS HTRS switch (RHFFB-200). Removes power and resets RCS logic circuitry.				

MAIN DISPLAY CONSOLE - PANEL 8

SM2A-03-SC012
 APOLLO OPERATIONS HANDBOOK

CONTROLS AND DISPLAYS

Control Name	Circuit Breaker	Power Source	Telemetry Code No. and Identity	Remarks
<p>5. C/M RCS Helium Dump Switch</p> <p>OFF</p>	<p>FC-1 C/M-S/M T1-10V11 MS A MS B (MS 7-29)</p>	<p>D-C main buses A and B</p>	<p>None</p>	<p>Guarded two-position toggle switch (activates explosive-operated valves). During normal entry, switch is placed to DUMP (up) position when main parachute line stretched to full. Remaining propellants are then burned off through 16 of the 12 RCS engines.</p> <p>The two positive pitch engines do not permit fuel dump or burn.</p> <p>DUMP switch will not be utilized during pad aborts or low altitude aborts, fuel only is retained on-board and the CM will land with fuel tanks full, but depressurized.</p> <p>Two-position toggle switch. Switch manually set to the up position after C/M propellant supply has been depleted (approximately 86 seconds, after activation of FUEL DUMP/BURN switch, for 10-engine burn and 132 seconds for 5-engine burn). All four propellant tank lines are purged with helium to ensure that no hypergolic propellant remains in the propellant distribution or engine systems. (Purge operation approximately 10 seconds.) The LOGIC and DUMP switches must both be in the up position before the purge operation can be initiated.</p> <p>Switch will not be utilized during abort operations if fuel is retained on-board.</p>
<p>6. C/M RCS Helium Dump Switch</p> <p>ON (up)</p>	<p>FC-1 C/M-S/M T1-10V11 MS A MS B (MS 7-29)</p>	<p>D-C main buses A and B</p>	<p>None</p>	<p>Same as above.</p>
<p>7. C/M RCS Helium Dump Switch</p> <p>OFF</p>	<p>FC-1 C/M-S/M T1-10V11 MS A MS B (MS 7-29)</p>	<p>D-C main buses A and B</p>	<p>None</p>	<p>Same as above.</p>
<p>8. C/M RCS Helium Dump Switch</p> <p>ON (up)</p>	<p>FC-1 C/M-S/M T1-10V11 MS A MS B (MS 7-29)</p>	<p>D-C main buses A and B</p>	<p>None</p>	<p>Same as above.</p>
<p>9. C/M RCS Helium Dump Switch</p> <p>OFF</p>	<p>FC-1 C/M-S/M T1-10V11 MS A MS B (MS 7-29)</p>	<p>D-C main buses A and B</p>	<p>None</p>	<p>Same as above.</p>

SM2A-03-SC012
APOLLO OPERATIONS HANDBOOK

CONTROLS AND DISPLAYS

Location	Name and Position	Function	Circuit Breaker	Power Source	Telemetry Code No. and Identity	Remarks
MDC-9	Coaxial bracket MDC Normal installation Survival transmitter installation Crossover installation	Connects VHF recovery antenna No. 1 to the VHF recovery beacon and VHF recovery antenna No. 2 to the VHF/AM transmitter-receiver. Connects either recovery antenna No. 1 or No. 2 to the GFAE survival transmitter. Connect GFAE survival transmitter to recovery antenna No. 1 (right connector). Connect GFAE survival transmitter to recovery antenna No. 2 (left connector).	N/A	None	None	Change is implemented by manually disconnecting RF coaxial connector from VHF recovery antenna No. 1 or No. 2 connector and reconnecting to coaxial connector on cable to GFAE survival transmitter. Permits two-way AM voice communications or beacon transmission on GFAE survival transmitter (243.0 mc) over antenna No. 1 and VHF-AM (296.8) on antenna No. 2. Permits two-way AM voice communications or beacon transmission on GFAE survival transmitter (243.0 mc) over antenna No. 2 and VHF recovery beacon transmission (243.0 mc) on antenna No. 2.
MDC-10	G&N system status lights CDU FAIL IMU FAIL IMU TEMP G&N ACCEL FAIL G&N ERROR GMBL LOCK	Indicates a failure in one or more of the coupling display units. Indicates a failure in the inertial measurement unit. Indicates that the IMU temperature is out of tolerance, i. e., exceeds normal temperature by 34°. Indicates a failure in one or more of the PIP accelerometers. Indicates an IMU, CDU, accelerometer and/or AGC error. Indicates a potential gimbal lock condition in the IMU (middle gimbal angle is greater than ±60 degrees with respect to the outer gimbal).	CAUT/ WARN MN A MN B (MDC-25)	D-C main buses A and B	CG5002X (CDU fail) CG5001X (IMU fail) CG5006X (IMU temp light) CG5000X (PIPA fail) CG5005X (Error detect) CG5003X (Gimbal lock warning)	Yellow lights indicate failure or out-of-tolerance condition when illuminated.

MAIN DISPLAY CONSOLE - PANELS 9 AND 10

SM2A-03-SC012
 APOLLO OPERATIONS HANDBOOK

CONTROLS AND DISPLAYS

Location	Name and Position	Function	Circuit Breaker	Power Source	Telemetry Code No. and Identity	Remarks
MDC-10 (Cont)	AGC PWR FAIL	Indicates a power failure in the Apollo guidance computer.	CAUT/ WARN MN A MN B (MDC-25)	D-C main buses A and B	CG5030X (Computer power fail light)	
	SCS status light				CH2030T (Combined attitude gyro temp)	When illuminated, the status light indicates an out-of-temperature condition in one or more of the three BMAGs. When light is out, BMAG outputs are usable.
	AGAP TEMP	Illuminates when the temperature of any one of three BMAGs in the SCS attitude gyro accelerometer package varies from 170±2°F.				
	EPS status lights				SF0039P (Press H2 tank 1) SF0040P (Press H2 tank 1)	Yellow lamp will illuminate if either or both H2 tanks are above or below proper pressure limits. Pressure in H2 tanks can be monitored by indicators on MDC-13.
	H2 PRESS	Indicates hydrogen tank pressure is as follows: a. 220 psia or below b. 270 psia or above.				
	O2 PRESS	Indicates oxygen tank pressure is as follows: a. 800 psia or below b. 950 psia or above.			SF0037P (Press O2 tank 1) SF0039 (Press O2 tank 2)	Yellow lamp will illuminate if either or both O2 tanks are above or below proper pressure limits. Pressure in O2 tanks can be monitored by indicators on MDC-13.
	RCS status lights	A and B lights are identical in operation within their respective systems. Indicates an underpressure condition in the fuel and oxidizer tanks of the respective system prior to system pressurization. Indicates an over or underpressure condition (below 265 psia or above 325 psia) in the fuel and oxidizer tanks of the respective propellant system.			None	All lights are yellow. The RCS INDICATOR switch can be used in conjunction with the propellant indicating devices to isolate a malfunction to a specific temperature, or pressure, within a particular RCS package. A temperature transducer is located on the inner surface of each S/M-RCS quad. A pressure transducer is installed in the helium line of each S/M-RCS quad and each C/M-RCS system. When the status lights are out, the applicable system is operable.
	C/M RCS A, B					
	S/M RCS A, B, C, D	Indicates one of the following: a. Package temperature below 63°F or above 175°F (nominal)				

MAIN DISPLAY CONSOLE - PANEL 10

SM2A-03-SC012
APOLLO OPERATIONS HANDBOOK

CONTROLS AND DISPLAYS

Location	Name and Position	Function	Circuit Breaker	Power Source	Telemetry Code No. and Identity	Remarks
MDC-10 (Cont)		b. Regulated helium pressure below 155 psia or above 215 psia (nominal).	CAUT/ WARN MN A MN B (MDC-25)	D-C main buses A and B	None	
	SPS status light SPS ROUGH ECO	Indicates FCMS cut-off of SPS engine due to excessive engine vibration level.	CAUT/ WARN MN A MN B (MDC-25)			Yellow light. Delay time for cutoff is nominally 70±20 milliseconds at a vibration level of 180 g's peak-to-peak. Delay time will be 30 to 70 milliseconds at a vibration level of 360 g's peak-to-peak. Light will extinguish when FCMS circuitry is reset.
MDC-11	ECS status lights H ₂ O ACCUM FAIL	Indicates when a minimum of three oxygen bubbles are detected in water expelled from H ₂ O accumulators.	CAUT/ WARN MN A MN B (MDC-25)	D-C main buses A and B	None	The yellow light illuminates in event of water accumulator diaphragm rupture. Oxygen will then enter the waste water network. A sensor is placed in the accumulator water outlet line. Oxygen bubbles in the water are sensed as a change in voltage. When three positive pulse signals (corresponding to three bubbles) are received, a voltage divider is unbalanced, resulting in light illumination.
	GLYCOL TEMP LOW	Indicates when water-glycol from space radiator outlet decreases to -30°F.			CF0020T (Temp space radiator outlet)	The yellow light illuminates to indicate water-glycol is approaching the temperature where flow is reduced. Continuous temperature is displayed by ECS RAD-OUTLET TEMP indicator (MDC-13). Transducer is placed in line downstream of space radiator outlet in LHCB, and furnishes signal for light and indicator.

MAIN DISPLAY CONSOLE - PANELS 10 AND 11

SM2A-03-SC012
APOLLO OPERATIONS HANDBOOK

CONTROLS AND DISPLAYS

Location	Name and Position	Function	Circuit Breaker	Power Source	Telemetry Code No. and Identity	Remarks
MDC-11 (Cont)	CO ₂ PP HI	Indicates when CO ₂ partial pressure reaches 7.6 mm Hg.	CAUT/ WARN MN A MN B (MDC-25)	D-C main buses A and B	CF0005P (Press CO ₂ partial)	The yellow light illuminates at upper end of normal range. A CO ₂ -odor absorber filter change is required only if the illumination of the light is not the result of temporarily increased crew activities.
	O ₂ FLOW HI	Indicates when total ECS oxygen flow reaches 1 lb per hr.			None	Continuous partial pressure is displayed by PART PRESS - CO ₂ indicator (MDC-13). The red light illuminates at critical flow rate which, if continuous, indicates cabin leakage, oxygen subsystem leakage, or mismanagement of oxygen subsystem. Continuous O ₂ flow is displayed by FLOW O ₂ indicator (MDC-13).
	SPS status lights					
	PITCH GMBL DR. FAIL	Indicates an over or under-current has occurred in the primary drive motor of the pitch gimbal actuator.				Yellow lights. Light indicator is a constant visual aid to assist in evaluating functional status of engine gimbal drive components.
	YAW GMBL DR. FAIL	Indicates an over or under-current has occurred in the primary drive motor of the yaw gimbal actuator.				
	SPS PRESS	Indicates oxidizer and/or fuel tank pressures (regulated helium pressures) are not within proper operating range (160 to 200 psia).				Yellow light. Two pressure transducers, one located in each (Ox and Fuel) regulated helium supply line, provide input to indicator. Continuous pressures are displayed by PRESSURE indicators on MDC-20.
	SPS WALL TEMP HI	Indicates wall temperature of SPS engine combustion chamber exceeds high operating temperature limit of 380°F.				Yellow light. Indicator input is provided by temperature sensor mounted in engine combustion chamber wall assembly.
	SPS PUSNR FAIL	Indicates one of the following: a. An unbalance in the remaining SPS propellants from the desired ratio (by weight) in excess of 300 lb or 90 percent of critical unbalance.				Yellow light is functional only during SPS engine firing or when TEST/AUTO/TEST switch (MDC-20) is in the TEST up or down position. Critical unbalance is that point at which the propellant utilization valve will no longer provide oxidizer adjustment.

MAIN DISPLAY CONSOLE - PANEL 11

CONTROLS AND DISPLAYS

Location	Name and Position	Function	Circuit Breaker	Power Source	Telemetry Code No. and Identity	Remarks
MDC-11 (Cont)	C&WS status light	b. Discrepancy of 300 lbs between the primary and auxiliary sensing systems. Indicates when power supply voltage (positive or negative) is outside of the 11.7 to 13.9 volt normal range.	CAUT/ WARN MN A MN B (MDC-25)	D-C main buses A and B	None	great enough to permit simultaneous propellant depletion. Switching to redundant power supply will extinguish status light. Audio portion of master alarm circuit will not operate, as the 12-volt tone generator power will be interrupted by a power supply failure.
	CAUT/WARN FAIL					
	EPS status lights F/C-BUS DISCONNECT	Indicates a fuel cell has automatically disconnected from the d-c main buses.				SC2120X Fuel cell 1 bus A disconnect SC2121X Fuel cell 2 bus A disconnect SC2122X Fuel cell 3 bus A disconnect SC2125X Fuel cell 1 bus B disconnect SC2126X Fuel cell 2 bus B disconnect SC2127X Fuel cell 3 bus B disconnect

MAIN DISPLAY CONSOLE - PANEL 11

SM2A-03-SC012
APOLLO OPERATIONS HANDBOOK

CONTROLS AND DISPLAYS

Location	Name and Position	Function	Circuit Breaker	Power Source	Telemetry Code No. and Identity	Remarks
MDC-11 (Cont)	F/C 1, F/C 2, and F/C 3	<p>Indicates one of the following conditions exist in the respective fuel cell:</p> <p>a. H₂ flow rate below 0.028 lb/hr or above 0.153 lb/hr</p> <p>b. O₂ flow rate below 0.22 lb/hr or above 1.22 lb/hr</p> <p>c. pH factor of 9 or over</p>	CAUT/ WARN MN A MN B (MDC-25)	D-C main buses A and B	<p>a. SC2139R Flow rate H₂ F/C 1</p> <p>SC2140R Flow rate H₂ F/C 2</p> <p>SC2141R Flow rate H₂ F/C 3</p> <p>b. SC2142R Flow rate O₂ F/C 1</p> <p>SC2143R Flow rate O₂ F/C 2</p> <p>SC2144R Flow rate O₂ F/C 3</p> <p>c. SC2160X pH factor water condition F/C 1</p> <p>SC2161X pH factor water condition F/C 2</p> <p>SC2162X pH factor water condition F/C 3</p>	<p>Yellow lights illuminate when any of the sensed parameters are out of tolerance. Switching the FUEL CELLS INDICATORS switch (MDC-18) to the position indicated by the illuminated status lights and observing the fuel cell displays, enables the crew to determine which parameter is out of tolerance. Alarm trigger values are presented in the Function column.</p>

MAIN DISPLAY CONSOLE - PANEL 11

SM2A-03-SC012
 APOLLO OPERATIONS HANDBOOK

CONTROLS AND DISPLAYS

Location	Name and Position	Function	Circuit Breaker	Power Source	Telemetry Code No. and Identity	Remarks
MDC-11 (Cont)		d. F/C skin temperature below 360°F or above 500°F	CAUT/ WARN MN A MN B (MDC-25)	D-C main buses A and B	d. SC2084T Temp F/C 1 skin SC2085T Temp F/C 2 skin SC2086T Temp F/C 3 skin	
		e. F/C condenser exhaust temperature below 155°F or above 175°F			e. SC2081T Temp F/C F cond exhaust SC2082T Temp F/C 2 cond exhaust SC2083T Temp F/C 3 cond exhaust	
		f. F/C outlet radiator temperature below -30°F			f. SC2087T Temp F/C 1 radiator outlet SC2088T Temp F/C 2 radiator outlet SC2089T Temp F/C 3 radiator outlet	

MAIN DISPLAY CONSOLE - PANEL 11

SM2A-03-SC012
 APOLLO OPERATIONS HANDBOOK

CONTROLS AND DISPLAYS

Location	Name and Position	Function	Circuit Breaker	Power Source	Telemetry Code No. and Identity	Remarks
MDC-11 (Cont)		g. H ₂ regulator pressure above 75 psia	CABT/ WARN MN A MN B (MDC-25)	D-C main buses A and B	g. SC2069P H ₂ pres- sure F/C 1 regulated SC2070P H ₂ pres- sure F/C 2 regulated	
		h. O ₂ regulator pressure above 75 psia			h. SC2066P O ₂ pres- sure F/C 1 regulated SC2067P O ₂ pres- sure F/C 2 regulated SC2068P O ₂ pres- sure F/C 3 regulated	
		i. N ₂ regulator pressure above 70 psia.			i. SC2060P N ₂ pres- sure F/C 1 regulated SC2061P N ₂ pres- sure F/C 2 regulated	

MAIN DISPLAY CONSOLE - PANEL 11

C-2

SM2A-03-SC012
APOLLO OPERATIONS HANDBOOK

CONTROLS AND DISPLAYS

Location	Name and Position	Function	Circuit Breaker	Power Source	Telemetry Code No. and Identity	Remarks
MDC-11 (Cont)	INV 1 TEMP HI, INV 2 TEMP HI, and INV 3 TEMP HI	Indicates an overtemperature (241°F) exists in the respective inverter.	CAUT/ WARN MN A MN B (MDC-25)	D-C main buses A and B	i. (Cont) SC2062P N2 pres- sure F/C 3 regulated	The yellow inverter overtemperature lights illuminate at +241°F and above.
		Indicates a d-c voltage drop below 26.25 ± 0.1 vdc on the respective d-c main bus.				
		Indicates the following conditions exist in any of the three-phases of the respective a-c bus: a. Undervoltage (95±3 vac) b. Overvoltage (130±2 vac)				
		Indicates an overload (30, 9 amps/0 for 15±5 seconds or 10, 11 amps for 5±1 second) exists on the respective a-c bus.				
	MN BUS A UNDER-VOLT and MN BUS B UNDERVOLT					
	AC BUS 1 FAIL and AC BUS 2 FAIL					The yellow main d-c bus undervoltage lights will not illuminate when the affected main bus reset switch is in the OFF position. The yellow a-c bus fail lights will not illuminate when affected a-c bus reset switch is in the OFF position. The inverters will not disconnect from the buses on an undervoltage condition, but will disconnect from bus on overload. Light must be reset.
	AC BUS 1 OVERLOAD and AC BUS 2 OVERLOAD					The inverter supplying the bus will be automatically disconnected at the time either of these yellow lights illuminate. Time versus overload is 5±1 seconds for a short circuit of 300-percent-rated current per phase and 10(-0, +5) seconds for a short circuit of 250-percent-rated current. Lamps will not illuminate when affected a-c bus reset switch is in the OFF position.
	CAUT/WARN switches					The output of both power supplies is +12 and -12 vdc, which is used in the caution and warning system electronics.
	POWER switch					

MAIN DISPLAY CONSOLE - PANEL 11

SM2A-03-SC012
APOLLO OPERATIONS HANDBOOK

CONTROLS AND DISPLAYS

Location	Name and Position	Function	Circuit Breaker	Power Source	Telemetry Code No. and Identity	Remarks
MDC-11 (Cont)	1	Applies d-c power to caution and warning system power supply No. 1.	CAUT/ WARN MN A MN B (MDC-25)	D-C main buses A and B	None	Nominal switch position is 1. Power is still applied to the C&WS; however, the master alarm circuit and those status lights activated as the result of analog signals will be inoperative.
	OFF	Removes d-c power from caution and warning system power supplies No. 1 and No. 2.				
	2	Applies d-c power to caution and warning system power supply No. 2.				
	MODE switch					
	CSM	a. Applies d-c power to 15 S/M system status lights, permitting illumination of lights upon receipt of malfunction signals.				Power to C/M system status lights is not removed with switch in either position. Power is removed only by placing C/W switch (MDC-13) to ACK position. CSM mode is selected at all times prior to CSM separation. Power is applied to the following 15 S/M status lights: PITCH GMBL DR FAIL, YAW GMBL DR FAIL, SPS PU SNSR FAIL, F/C BUS DISCONNECT. O ₂ PRESS, H ₂ PRESS, SPS PRESS, S/M RCS A, S/M RCS B, S/M RCS C, S/M RCS D, SPS WALL TEMP HI, F/C 1, F/C 2, and F/C 3. Power is applied to the following 4 S/M event channels: PITCH GMBL DR FAIL, YAW GMBL DR FAIL, SPS PU SNSR FAIL, and F/C BUS DISCONNECT.
	C/M	b. Applies d-c power to 4 S/M event channels, permitting circuitry to simulate lamp load when C/W switch is in ACK position. c. Opens d-c ground return path, inhibiting C/M RCS A and C/M RCS B lamp circuits prior to CSM separation.				C/M mode is selected subsequent to CSM separation.
		a. Removes d-c power to 15 S/M system status lights. b. Removes d-c power to 4 S/M event channels. c. Completes d-c ground return path, enabling C/M RCS A and C/M RCS B lamp circuits after CSM separation.				

MAIN DISPLAY CONSOLE - PANEL 11

SM2A-03-SC012
 APOLLO OPERATIONS HANDBOOK

CONTROLS AND DISPLAYS

Symbol	Name and Position	Function	Circuit Breaker	Power Source	Telemetry Code No. and Identity	Remarks
39-11	ANALOG EVENT TIMER window	The event timer provides the crew with a means of monitoring and timing events. Indications from 00 minutes and 00 seconds (00-00) to 59 minutes and 59 seconds (59-59) are obtainable in a countup or countdown mode. In a countup mode, when 59-59 is recorded, the counter will proceed to 00-00 and continue to count up. In a countdown mode, continuous counting is also available.	EVENT TIMER MIN A MIN B (MDC-25)	D-C main buses A and B	None	The event timer is a reference system only and is automatically reset to zero when an abort is automatically or manually initiated. The event timer starts automatically when lift-off occurs.
	DIGITAL EVENT TIMER switches					
	RESET switch	Resets the event timer (MDC-5) to zero.				The event timer is automatically reset to zero and starts counting up when an abort is automatically or manually initiated. The switch is momentary on towards the RESET position and maintain on in the other two positions.
	UP	Completes circuitry for the event timer to time up.				
	DOWN	Completes circuitry for the event timer to time down.				
	START/STOP switch					
	START	Starts the event timer.				The event timer starts automatically when lift-off occurs. The switch is momentary on towards the START position and maintain on in the other two positions.
	Center	No function.				
	STOP	Stops the event timer.				
	MIN switch					
	TENS	Runs the MIN indicating drums in tens.				The control switches provide a means of running the event timer to any desired setting and are spring-loaded to the center position. The indicating drums can be run up or down, depending on the position of the RESET/UP/DOWN switch.
	Center	No function.				
	UNITS	Runs the second MIN indicating drum in units.				
	SEC switch					
	TENS	Runs the SEC indicating drums of the event timer in tens.				
	Center	No function.				
	UNITS	Runs the second SEC indicating drum in units.				

SM 2A-03-SC 012-1-1

SM2A-03-SC012
APOLLO OPERATIONS HANDBOOK

CONTROLS AND DISPLAYS

Location	Name and Position	Function	Circuit Breaker	Power Source	Telemetry Code No. and Identity	Remarks
MDC-11 (to out)	DRIFTAL EVENT TIMER switches	The event timer provides the crew with a means of monitoring and timing events. Indications from 00 minutes and 00 seconds (00-00) to 59 minutes and 59 seconds (59-59, are obtainable in a countup or countdown mode. In a countup mode, when 59-59 is recorded, the counter will proceed to 00-00 and continue to count up. In a countdown mode, continuous counting is also available.	EVENT TIMER MN A MN B (MDC-25)	D-C main buses A and B	None	This event timer is for reference only. The event timer starts automatically when lift-off occurs.
	RESET/UP/DOWN switch	Reset the event timer (MDC-11) to zero.				The switch is momentary on towards the RESET position and maintained on in the other two positions.
	UP	Completes circuitry for the event timer to time up.				
	DOWN	Completes circuitry for the event timer to time down.				
	START/STOP switch					
	START	Starts the event timer.				The event timer starts automatically when lift-off occurs. The switch is momentary on towards the START position and maintained on in the other two positions.
	Center	No function.				
	STOP	Stops the event timer.				
	MIN switch					
	TENS	Runs the MIN indicating drums in tens.				The control switches provide a means of running the event timer to any desired setting and are spring-loaded to the center position. The indicating drums can be run up or down, depending on the position of the RESET/UP/DOWN switch.
	Center	No function.				
	UNITS	Runs the second MIN indicating drum in units.				

MAIN DISPLAY CONSOLE - PANEL 11

APOLLO OPERATIONS HANDBOOK

CONTROLS AND DISPLAYS

Category	Control Panel	Function	Circuit Breaker	Power Source	Telemetry Code No. and Identity	Remarks
C/M RCS indicators	TEMP	Indicates temperature of S/M RCS package A, B, C, or D, as selected by the RCS INDICATORS switch. (Meter range: 0 to 200° F.)	INSTRUMENTS—ESS MIN A MIN B (MDC-22)	D-C main buses A and B	Package temp: A-SR5005T B-SR5006T C-SR5007T D-SR5008T	Four indicators are identical in operation. Each one consists of a d'Arsonval-type meter with a fixed dial and movable pointer. Pointer movement is vertical, as observed from crew couch. Each indicator is capable of accepting input signals from the C/M or S/M RCS. Displayed information is determined by the position of the RCS INDICATORS switch.
	HEG	Indicates temperature of S/M RCS helium supply for A, B, C, or D, as selected by the RCS INDICATORS switch. (Meter range: 0 to 400 psia; must be transposed to degrees. Refer to Remarks.)				
PRESS	He	Indicates helium tank pressure of S/M RCS package A, B, C, or D, as selected by the RCS INDICATORS switch. (Meter range: 0 to 5000 psia.)			He tank pressure: A-SR5001P B-SR5002P C-SR5003P D-SR5004P	The S/M RCS helium tank supply temperature is indicated as psia on this indicator. The range of the indicator is 0 to 400 psia, bottom to top scale. 0 psia is equivalent to 0° F. and 400 psia is equivalent to 150° F. The indicated number (psia) on this indicator, plus the helium tank supply pressure readout (psia) would be utilized by the crew to determine on the nomogram the propellant quantity remaining in a given quad in percent.
	MANF	Indicates regulated helium pressure of S/M-RCS package A, B, C, or D, as selected by the RCS INDICATORS switch. (Meter range: 0 to 400 psia.)				
C/M RCS indicators	TEMP	Indicates helium tank temperature of C/M RCS system A or B, as selected by the RCS INDICATORS switch. (Meter range: 0 to 200° F.)			Regulated He press: A-SR5729P B-SR5776P C-SR5817P D-SR5830P	
	He	Indicates helium tank pressure of C/M RCS system A or B, as selected by the RCS INDICATORS switch. (Meter range: 0 to 5000 psia.)				
PRESS	He	Indicates helium tank pressure of C/M RCS system A or B, as selected by the RCS INDICATORS switch. (Meter range: 0 to 5000 psia.)			He tank temp: A-CR0003T B-CR0004T	
	He	Indicates helium tank pressure of C/M RCS system A or B, as selected by the RCS INDICATORS switch. (Meter range: 0 to 5000 psia.)				

SM2A-03-SC012
APOLLO OPERATIONS HANDBOOK

CONTROLS AND DISPLAYS

Location	Name and Position	Function	Circuit Breaker	Power Source	Telemetry Code No. and Identity	Remarks
MDC-12 (Cont)	F	Indicates regulated helium pressure to the fuel tank of C/M RCS system A or B, as selected by the RCS INDICATORS switch. (Meter range: 0 to 400 psia.)	INSTRUMENTS— ESS MN A MN B (MDC-22)	D-C main buses A and B	Regulated He press (Fuel system) A-CR0005P B-CR0006P	
	OX	Indicates regulated helium pressure to the oxidizer tank of C/M RCS system A or B, as selected by the RCS INDICATORS switch. (Meter range: 0 to 400 psia.)			Regulated He press (OX system) A-CR0011P B-CR0012P	
	RCS INDICATORS switch	Selects inputs to the propellant temperature, and pressure indicating devices. C/M sections A and B functions are identical within their respective systems. S/M sections A, B, C, and D functions are identical within their respective systems.	N/A	N/A	None	Six-position rotary switch. C/M section of switch, positions A and B, permits monitoring command module propellant systems A and B. S/M section of switch, positions A, B, C, and D permits monitoring service module propellant systems of quads A, B, C, and D.
	C/M section A (B)	Connects C/M RCS system A (B) signal outputs from temperature and pressure transducers to the appropriate indicating devices.				
	S/M section A (B, C, D)	Connects S/M RCS quad A (B, C, and D) signal outputs from temperature and pressure transducers and the propellant quantity sensing computer to the appropriate indicating devices.				

MAIN DISPLAY CONSOLE - PANEL 12

Basic Date 12 Nov 1968

Change Date _____

Page 1.49

SM2A-03-SC012
APOLLO OPERATIONS HANDBOOK

CONTROLS AND DISPLAYS

Location	Name and Position	Function	Circuit Breaker	Power Source	Telemetry Code No. and Identity	Remarks
MDC-12 (C/M)	100-hour clock	Displays mission elapsed time in 10-hour increments up to 400 hours.	None	None	None	The indicator has two set-knobs. One starts, stops, and resets the clock; the other sets the hour and minute hands, and winds the clock.
MDC-13	C/W switch NORMAL	Applies d-c power to the following: a. Twenty-five C/M system status lights, permitting illumination of lights upon receipt of malfunction signals. b. One pole of CAUT/WARN-MODE switch, which in turn may apply power to 15 S/M system status lights. c. MASTER ALARM switch-light on MDC-3, permitting illumination of light upon receipt of malfunction signals.	CAUT/WARN MN A MN B (MDC-25)	D-C main buses A and B	None	Switch is set to NORMAL at all times other than during the ascent phase or when dark adaptation is required. With switch in this position and upon receipt of a malfunction signal, the appropriate system status light and the MASTER ALARM lights will illuminate, and an audio alarm tone is sent to each headset. Power is applied to the following 25 C/M system status lights: CDU FAIL, G&N ACCEL FAIL, AGC PWR FAIL, IMU FAIL, G&N ERROR, IMU TEMP, GMEL LOCK, AGAP TEMP, SPS ROUGHCO, H ₂ O ACCUM FAIL, O ₂ FLOW HI, AC BUS 1 FAIL, AC BUS 1 OVERLOAD, AC BUS 2 FAIL, AC BUS 2 OVERLOAD, MN BUS A UNDERVOLT, MN BUS B UNDERVOLT, INV 1 TEMP HI, INV 2 TEMP HI, INV 3 TEMP HI, C/M RCS A, C/M RCS B, GLYCOL TEMP LOW, CO ₂ PP HI, and CAUT/WARN FAIL. For a list of the 15 S/M system status lights, refer to Remarks column of CAUT/WARN-MODE switch (MDC-11), CSM position.

MAIN DISPLAY CONSOLE - PANELS 12 AND 13

SM2A-03-SC012
APOLLO OPERATIONS HANDBOOK

CONTROLS AND DISPLAYS

Location	Name and Position	Function	Circuit Breaker	Power Source	Telemetry Code No. and Identity	Remarks
MDC-13 (Cont)	BOOST	<p>a. Applies d-c power to 25 C/M system status lights, permitting illumination of lights upon receipt of malfunction signals.</p> <p>b. Applies d-c power to one pole of CAUT/WARN-MODE switch, which in turn may apply power to 15 S/M systems status lights.</p> <p>c. Removes d-c power from MASTER ALARM switch-light on MDC-3, preventing illumination of light upon receipt of malfunction signals during the ascent phase.</p>	CAUT/ WARN MN A MN B (MDC-25)	D-C main buses A and B	None	Switch set to BOOST at prelaunch to preclude the possibility of confusion on MDC-3 between the red MASTER ALARM light and the adjacent red ABORT light during the critical ascent phase.
	ACK	<p>a. Removes d-c power from 25 C/M system status lights, preventing illumination of lights upon receipt of malfunction signals.</p> <p>b. Removes d-c power from one pole of CAUT/WARN MODE switch, thereby removing power to 15 S/M system status lights.</p> <p>c. Places push-switch function of both MASTER ALARM switch-lights into the d-c circuit of the system status lights. This prevents illumination of the system status lights upon receipt of malfunction signals until either push-switch is pressed to complete the circuit.</p>				Switch is set to ACK to retain dark adaptation. With switch in this position and upon receipt of a malfunction signal, only the MASTER ALARM lights will illuminate and an alarm tone be sent to each headset. To determine the malfunction either MASTER ALARM switch-light may be pressed to illuminate the appropriate system status light. The light will remain illuminated only as long as the switch-light is pressed. Although upon release all system status lights are extinguished, they may be recalled as long as the malfunction exists by again pressing either switch-light.
	POWER switch	Controls power to senior pilots module in audio center equipment.	T/C GROUP 5 (MDC-22)	Flight and postlanding bus		The audio center will not be activated unless the POWER switch is in PTT or VOX position.
	PTT	Applies d-c power to audio and control circuits.				Intercom capability when cobra cable PTT/CW switch is in CW and transmit capability with PTT/CW switch in PTT.
	OFF	Removes power from senior pilots audio center equipment module and controls.				

MAIN DISPLAY CONSOLE - PANEL 13

APOLLO OPERATIONS HANDBOOK

CONTROLS AND DISPLAYS

Location	Name and Position	Function	Circuit Breaker	Power Source	Telemetry Code No. and Identity	Remarks	
MDC-13 (Cont)	VOX	a. Applies d-c power to audio and control circuits. b. Enables VOX control of mike amplifier by supplying ground to VOX circuitry.	T/C GROUP 5 (MDC-22)	Flight and postlanding bus	None	VOX operation permits voice transmission and transmitter keying of intercom, HF Recovery transmitter and voice recorder when cobra cable PTT/CW switch is at PTT.	
	S-BAND switch	No effect. S-Band T/R function supplied by cobra cable PTT key.	N/A	Audio center equipment			The S-BAND, HF, VHF-AM, and INTERCOM switches all control ground return paths for appropriate diode switching and isolation circuitry in the senior pilots module of the audio center equipment to allow transmission and reception, or reception alone, of voice signals over selected equipment. The HF and VHF-AM switches also provide ground return paths for the HF and VHF-AM transmitter keying circuits when in the T/R position.
	T/R	Prevents senior pilot from transmitting or receiving voice over USBE.				Provides power ground through audio center VOX circuit for HF transmitter transmit-receive relay and voice recorder power relay.	
	OFF	Enables senior pilot to receive voice from USBE.					
	REC						
	R CDR/HF switch					VHF-AM transmits, in addition to S-Band voice, when cobra cable PTT key is closed. Cobra cable PTT/CW switch must be at PTT, and audio center POWER switch must be at PTT.	
	T/R	a. Enables senior pilot to transmit and receive voice over HF transmitter when operating in AM or SSB mode. b. Enables voice recorder through VOX circuit.					
	OFF	Prevents senior pilot from transmitting or receiving voice over HF transmitter.					
		REC	Enables senior pilot to receive voice from HF transmitter when operating in AM or SSB mode.				
	VHF-AM switch						
	T/R	Enables senior pilot to transmit and receive voice over VHF-AM transmitter-receiver when operating in T/R mode.					
	OFF	Prevents senior pilot from transmitting or receiving voice over VHF-AM transmitter-receiver.					

MAIN DISPLAY CONSOLE - PANEL 13

SM2A-03-SC012
APOLLO OPERATIONS HANDBOOK

CONTROLS AND DISPLAYS

Location	Name and Position	Function	Circuit Breaker	Power Source	Telemetry Code No. and Identity	Remarks	
MDC-13 (Cont)	REC	Enables senior pilot to receive voice from VHF-AM transmitter-receiver.	N/A	Audio center equipment	None		
	INTERCOM switch						
	T/R	Enables senior pilot to transmit and receive voice over the intercom system.					Audio center POWER switch must be at VOX to enable mike amplifier when cobra cable PTT/CW switch is at PTT.
	OFF	Prevents senior pilot from transmitting or receiving voice over intercom system.					
	REC	Enables senior pilot to receive voice from intercom system.					
	VOX SENS control	Increases or decreases sensitivity of voice-operated relay circuitry in senior pilots audio center module.					These three controls are thumbwheel-type potentiometers which may be rotated upward or downward, as required.
	INTERCOM BALANCE control	Increases or decreases level of audio signal received by senior pilot from RF equipment relative to that received from intercom bus.					Position 9 most sensitive.
	VOLUME control	Increases or decreases level of audio signal from senior pilots earphone amplifier to earphone.					
	TANK PRESSURE indicators						
	H ₂ group Indicators 1 and 2	Displays H ₂ tank No. 1 and No. 2 pressure and is used as follows: a. Determine tank heater performance. b. Detect leaks.	ESSEN-TIAL-3 (RHEB 204) and fuse in S/M	S/M INST PWR DIST		SF0039P (Press H ₂ tank No. 1) SF0040P (Press H ₂ tank No. 2)	Displays for H ₂ and O ₂ tanks No. 1 and 2 operate prior to CSM separation only. The indicator function is controlled by pressure transducers located in H ₂ tank No. 1 and No. 2 outlet lines. These transducers are also connected to C&WS, operating the H ₂ PRESS light on MDC-10. H ₂ operating range is 230 to 260 psia. Alarm trigger values are 220 psia low, and 270 psia high.

MAIN DISPLAY CONSOLE - PANEL 13

SM2A-03-SC012
APOLLO OPERATIONS HANDBOOK

CONTROLS AND DISPLAYS

Location	Name and Position	Function	Circuit Breaker	Power Source	Telemetry Code No. and Identity	Remarks
MDC-13 (Cont)	O ₂ group Indicator 1	Displays pressure of O ₂ tank No. 1 or ECS surge tank as selected by O ₂ PRESS IND switch (MDC-13) and is used as follows: a. Determine tank heater performance. b. Detect leaks. c. Verify surge tank pressure.	ESSENTIAL-3 (RHER 204) and fuse in S/M	S/M INST PWR DIST	SF0037P (Press O ₂ tank No. 1) CF0006P (Press surge tank)	With O ₂ PRESS IND switch at TANK 1, the indicator function is controlled by a pressure transducer located in O ₂ tank No. 1 outlet line. Transducer also connected to C&WS, operating O ₂ PRESS light on MDC-10. O ₂ operating range is 865 to 935 psia. Alarm trigger values are 800 psia low and 950 psia high. With O ₂ PRESS IND switch at SURGE TANK position, indicator displays signal from ECS surge tank pressure transducer.
	Indicator 2	Displays O ₂ tank No. 2 pressure and is used as follows: a. Determine tank heater performance. b. Detect leaks.			SF0038P (Press O ₂ tank No. 2)	The indicator function is controlled by a pressure transducer located in O ₂ tank No. 2 outlet line. Transducer also connected to C&WS, operating O ₂ PRESS light on MDC-10. O ₂ operating range is 865 to 935 psia. Alarm trigger values are 800 psia low, and 950 psia high.
	TANK QUANTITY indicator H ₂ group Indicator 1	Displays quantity of H ₂ remaining in tank No. 1.	CRYO-GENIC SYSTEM-QTY AMPL 1 AC 1 - ØC (MDC-22)	A-C bus No. 1 ØC	SF0030Q (Quantity H ₂ tank No. 1)	H ₂ quantity display range is 0 to 28 lb.
	Indicator 2	Displays quantity of H ₂ remaining in tank No. 2.	CRYO-GENIC SYSTEM-QTY AMPL 2 AC 2 - ØC (MDC-22)	A-C bus No. 2 ØC	SF0031Q (Quantity H ₂ tank No. 2)	

MAIN DISPLAY CONSOLE - PANEL 13

SM2A-03-SC012
 APOLLO OPERATIONS HANDBOOK

CONTROLS AND DISPLAYS

Location	Name and Position	Function	Circuit Breaker	Power Source	Telemetry Code No. and Identity	Remarks
MDC-13 (Cont)	O ₂ group Indicator 1	Displays quantity of O ₂ remaining in tank No. 1.	CRYO-GENIC SYSTEM - QTY AMPL 1 AC 1 - ØC (MDC-22)	A-C bus No. 1 ØC	SF003ZQ (Quantity O ₂ tank No. 1)	O ₂ quantity display range is 0 to 320 lb.
	Indicator 2	Displays quantity of O ₂ remaining in tank No. 2.	CRYO-GENIC SYSTEM - QTY AME L 2 AC 2 - ØC (MDC-22)	A-C bus No. 2 ØC	SF0033Q (Quantity O ₂ tank No. 2)	Redundant heater elements in each H ₂ tank requires 10 watts of power for each element. Switch at AUTO position will apply d-c voltage to H ₂ tanks No. 1 and 2 redundant heater elements when pressure switches in both tanks are in a low-pressure position at 230 psia or lower, and remove d-c voltage when either pressure switch is in a high-pressure position at 266 psia or higher.
	H ₂ HEATERS switches Switches 1 and 2 AUTO OFF ON	Controls d-c power to H ₂ tanks No. 1 and 2 heater elements, respectively. Enables automatic pressure switches to control d-c power to H ₂ tanks No. 1 and 2 heater elements. Disconnects d-c power from H ₂ tanks No. 1 and 2 heater elements. Controls d-c power directly to H ₂ tanks No. 1 and 2 heater elements.	CRYO-GENIC SYSTEM - TANK HEATERS - H ₂ - 1 MN A (MDC-22) CRYO-GENIC SYSTEM - TANK HEATERS - H ₂ - 2 MN B (MDC-22)	D-C main bus A D-C main bus B	None	Switch at ON (manual) position bypasses the pressure switches applying d-c voltage directly to the same redundant heater elements employed for automatic operation.

MAIN DISPLAY CONSOLE - PANEL 13

APOLLO OPERATIONS HANDBOOK

CONTROLS AND DISPLAYS

Location	Name and Position	Function	Circuit Breaker	Power Source	Telemetry Code No. and Identity	Remarks
MDC-13 (Cont)	O ₂ HEATERS switches Switches 1 and 2	Controls d-c power to O ₂ tanks No. 1 and 2 heater elements, respectively.	CRYOGENIC SYSTEM - TANK HEATERS - O ₂ - 1 MN A (MDC-22) CRYOGENIC SYSTEM - TANK HEATERS - O ₂ - 2 MN B (MDC-22)	D-C main bus A	None	Redundant heater elements in each O ₂ tank requires 77.5 watts of power for each element.
	AUTO	Enables automatic pressure switches to control d-c power to O ₂ tanks No. 1 and 2 heater elements.				Switch at AUTO position will apply d-c voltage to O ₂ tanks No. 1 and 2 redundant heater elements when pressure switches in both tanks are in a low-pressure position at 865 psia or lower and will remove d-c voltage when either pressure switch is in a high-pressure position at 935 psia or higher.
	OFF	Disconnects d-c power from O ₂ tanks No. 1 and 2 heater elements.				Switch at ON (manual) position bypasses the pressure switches, applying d-c voltage directly to the same redundant heater elements employed for automatic operation.
	ON	Controls d-c power directly to O ₂ tanks No. 1 and 2 heater elements.				Switch at ON (manual) position bypasses the pressure switches, applying d-c voltage directly to the same redundant heater elements employed for automatic operation.
	O ₂ PRESS IND switch					TANK PRESSURE-i-O ₂ indicator is shared by two pressure signals.
	TANK 1	Connects output of O ₂ tank No. 1 pressure transducer to O ₂ tank No. 1 TANK PRESSURE indicator (MDC-13).	ESSENTIAL - 3 (RHEB 204) and fuse in S/M	S/M INSTR PWR DIST	SF0037P (Press O ₂ tank 1)	Normal position of switch prior to CSM separation except for periodic surge tank readouts.
	SURGE TANK	Connects output of ECS SURGE TANK pressure transducer to O ₂ tank No. 1 TANK PRESSURE indicator.	INSTRUMENTS ESS - MN A and MN B (MDC-22), also ESSENTIAL - 2 (RHEB 204)	D-C main buses A and B	CF0006P (Press surge tank)	Normal position of switch following CSM separation.

MAIN DISPLAY CONSOLE - PANEL 13

SM2A-03-5C012
 APOLLO OPERATIONS HANDBOOK

CONTROLS AND DISPLAYS

Location	Name and Position	Function	Circuit Breaker	Power Source	Telemetry Code No. and Identity	Remarks.
MDC-13 (Cont)	H ₂ FANS switches Switches 1 and 2	Controls a-c power to H ₂ tanks No. 1 and 2 fan motors, respectively.	CRYOGENIC TANK FAN MOTORS -1- AC 1 ØA ØB ØC (MDC-22)	A-C bus No. 1	None	Redundant fan motors in each H ₂ tank requires 63VA total.
	AUTO	Applies a-c power to contacts on motor switch which controls 3Ø a-c power to circulating fan motors in H ₂ tanks No. 1 and 2.				Switch at AUTO position will apply a-c voltage to H ₂ tanks No. 1 and 2 redundant fan motors when pressure switches in both tanks are in a low-pressure position at 230 psia or lower and will remove a-c voltage when either pressure switch is in a high-pressure position at 260 psia or higher.
	OFF	Disconnects 3Ø a-c power from H ₂ tanks No. 1 and 2 circulating fan motors.	CRYOGENIC TANK FAN MOTORS -2- AC 2 ØA ØB ØC (MDC-22)	A-C bus No. 2		Switch at ON (manual) position bypasses the pressure switches, applying a-c power directly to the same redundant H ₂ tank fan motors employed for automatic operation.
	ON	Controls 3Ø a-c power directly to circulating fan motors in H ₂ tanks No. 1 and 2				Redundant fan motors in each O ₂ tank requires 148VA total.
O ₂ FANS switches	Switches 1 and 2	Applies a-c power to contacts on motor switch which controls 3Ø a-c power to circulating fan motors in O ₂ tanks No. 1 and 2.	CRYOGENIC TANK FAN MOTORS -1- AC 1 ØA ØB ØC (MDC-22)	A-C bus No. 1		Switch at AUTO position will apply a-c power to O ₂ tank No. 1 and 2 redundant fan motors when pressure switches in both tanks are in a low-pressure position at 865 psia or lower and will remove a-c voltage when either pressure switch is in a high-pressure position at 935 psia or higher.
	AUTO	Disconnects 3Ø a-c power from O ₂ tanks No. 1 and 2 circulating fan motors.				Switch at ON (manual) position bypasses the pressure switches, applying a-c power directly to the same redundant O ₂ tank fan motors employed for automatic operation.
	OFF	Controls 3Ø a-c power directly to circulating fan motors in O ₂ tanks No. 1 and 2.	CRYOGENIC TANK FAN MOTORS -2- AC 2 ØA ØB ØC (MDC-22)	A-C bus No. 2		Normal steam duct pressure operating range is 0.97 to 0.145 psia.
	ON	Provides pressure indication of steam discharged from water-glycol evaporator.	ECS - TRANS-DUCER PRESS GROUPS 2 MN A MN B (MDC-22)	D-C main buses A and B	CF0034P (Press glycol evap out steam)	
GLY EVAP STEAM PRESS indicator						

MAIN DISPLAY CONSOLE--PANEL 13

APOLLO OPERATIONS HANDBOOK

CONTROLS AND DISPLAYS

Indicator Position	Function	Circuit Breaker	Power Source	Telemetry Code No. and Identity	Remarks
MDC-11 PRESS GLY DISCH indicator	Provides static pressure indication of water-glycol pump discharge	ECS- TRANS- DUCER- PRESS GROUPS 1 MN A MN B MDC-22)	D-C main buses A and B	CF0016P (Press glycol pump outlet)	Normal water-glycol pump operating range indications are as follows: Prelaunch (GSE and onboard pumps): 14 to 18 psia Prelaunch (onboard pumps): 45 to 55 psia Normal flight: 37 to 45 psia Emergency flight: 37 to 45 psia
FLOW O ₂ indicator	Provides total rate-of-flow indication of oxygen supplied to the ECS downstream of the flow transducer.	ECS TRANS- DUCER - PRESS GROUPS 2 MN A MN B MDC-22)		CF0035R (Flow rate ECS O ₂)	Indicator will not show O ₂ flow upstream of transducer, such as through PLSS FILL valve (LHEB-314) main regulator or surge tank relief valve action, or line leakage. O ₂ FLOW HI system status light (red) is located on MDC-11 and illuminates at a flow rate of 1.0 lb/hr. Normal O ₂ flow operating range indications are from 0.20 to 0.45 lb/hr during prelaunch and in flight.
ΔP SUIT COMPR indicator	Provides pressure differential indication between suit compressor inlet and outlet manifolds to determine degree of compressor efficiency.	ECS TRANS- DUCER - PRESS GROUPS 1 MN A MN B MDC-22)		CF0015P (Press suit compressor diff)	Suit compressor ΔP operating range indications are as follows: 0.7 to 0.9 psi during prelaunch 0.3 to 0.4 psi during normal space flight 0.2 to 0.3 psi during emergency space flight.
GLY ACCUM-QUANTITY indicator	Provides quantity indication of water-glycol in accumulator.			CF0019Q (Quantity glycol accum)	Capacity of accumulator is 1.36 lb. Normal accumulator operating range indications are as follows: Prelaunch (GSE) and onboard pump: 0% Normal flight: 40 to 60% Emergency flight: 40 to 60%
WATER-QUANTITY indicator	Provides quantity indication of waste water tank or potable water tank as selected by H ₂ O IND switch (MDC-13).	ECS TRANS- DUCER- WASTE & POT H ₂ O MN A MN B MDC-22)		CF0009Q (Quantity waste water tank) CF0010Q (Quantity potable H ₂ O tank)	Capacities of the water tanks are: 36 lb of potable water and 56 lb of waste water. Water quantity indications are dependent upon a selected mission profile and specific times during the mission.

MAIN DISPLAY CONSOLE - PANEL 11

APOLLO OPERATIONS HANDBOOK

CONTROLS AND DISPLAYS

Location	Label and Position	Function	Circuit Breaker	Power Source	Telemetry Code No. and Identity	Remarks
MDC-11 (Cont)	ECS RAD-OUTLET TEMP indicator	Provides temperature indication of water-glycol returned to C/M from S/M space radiators (or from GSE during prelaunch).	ECS-TRANS-DUCER TEMP MN A MN B (MDC-22)	D-C main buses A and B	CF0020T (Temp space radiator outlet)	GLYCOL TEMP LOW system status light (yellow) is located on MDC-11, and illuminates at -30°F. Normal ECS radiator outlet temperature operating range is 30° to 102°F.
	GLY EVAP-OUTLET TEMP indicator	Provides temperature indication of water-glycol at outlet of water-glycol evaporator.				
	TEMP indicators SUIT	Provides temperature indication of suit circuit atmosphere.	CF0008T (Temp suit supply main)		Temperature sensor located in suit heat exchanger outlet duct. Normal suit circuit operating range indications are 45° to 55°F during prelaunch and in flight.	
	CABIN	Provides average temperature indication of cabin atmosphere.	CF0002T (Temp cabin)		Sensor located near inlet to cabin air fans. Normal cabin operating range indications are 50° to 70°F during prelaunch and 70° to 80°F in flight.	
	PRESS indicators SUIT	Provides pressure indication of suit circuit atmosphere.	ECS-TRANS-DUCER PRESS GROUPS I MN A MN B (MDC-22)		CF0012P (Press suit demand reg sense)	Pressure transducer located at demand regulator sensing port. Normal suit circuit operating range indications are as follows: 14.7 psia during prelaunch, 4.7 to 5.3 psia during normal flight mode, and 3.75±0.25 psia during emergency flight mode.

MAIN DISPLAY CONSOLE - PANEL 11

APOLLO OPERATIONS HANDBOOK

CONTROLS AND DISPLAYS

Symbol	Name and Position	Function	Circuit Breaker	Power Source	Telemetry Code No. and Identity	Remarks
MEM 13 (C/N)	CAMP	Provides pressure indication of cabin atmosphere.	ECS - TRANS - DUCER - PRESS GROUPS 2 MN A MN B (MDC-22)	D-C main buses A and B	CF0001P (Pressure cabin)	Pressure transducer located inside LHFEF. Normal cabin operating range indications are as follows: 14.7 psia during prelaunch, 4.8 to 5.2 psia during normal space flight, and 0.0 psia during emergency space flight.
	PART PRESS CO ₂ indicator	Provides partial pressure indication of CO ₂ in suit circuit atmosphere.	ECS - TRANS - DUCER - PRESS GROUPS 2 MN A (MDC-22)	D-C main bus A	CF0005P (Press CO ₂ partial)	CO ₂ sensor is located between inlet and outlet manifolds of suit circuit in LHFEF. The CO ₂ partial pressure normal metabolic operating range is 0.0 to 7.6 mm Hg, and the emergency metabolic operating range is 7.6 to 15.0 mm Hg. Both ranges are for an unlimited length of time. CO ₂ PP HI system status light (MDC-11) illuminates at 7.6 mm Hg. This indicates CO ₂ level has risen to the upper end of the normal operating range.
	H ₂ O ACCUM switches AUTO 1/MAN/ AUTO 2 switch	a. Removes d-c power from H ₂ O ACCUM-ON 1/ON 2 switch (MDC-13). b. Applies d-c power to No. 1 cyclic accumulator control unit to automatically time and actuate No. 1 cyclic accumulator valve for 10 seconds every 10 minutes.	ECS-H ₂ O ACCUM- MN A (MDC-22)	D-C main bus A	None	1. automatic mode, 10-second pulse signal for accumulator operation is received from CTE.
	MAN	a. Removes d-c power from No. 1 and No. 2 cyclic accumulator control units. b. Applies d-c power to H ₂ O ACCUM-ON 1/ON 2 switch, permitting manual control of No. 1 or No. 2 cyclic accumulator valves.	ECS-H ₂ O ACCUM- MN A MN B (MDC-22)	D-C main buses A and B		Switch position selects manual backup mode, permitting manual cyclic accumulator valve actuation in event both cyclic accumulator automatic control units should fail.

MAIN DISPLAY CONSOLE - PANEL 13

SM2A-03-SC012
APOLLO OPERATIONS HANDBOOK

CONTROLS AND DISPLAYS

Location	Name and Position	Function	Circuit Breaker	Power Source	Telemetry Code No. and Identity	Remarks
MDC-13 (Cont)	AUTO 2	a. Removes d-c power from H ₂ O ACCUM-ON 1/ON 2 switch. b. Applies d-c power to No. 2 cyclic accumulator control unit to automatically time and actuate No. 2 cyclic accumulator valve for 10 seconds every 10 minutes.	ECS - H ₂ O ACCUM-MN B (MDC-22)	D-C main bus B	None	
	ON 1/ON 2 switch					
	ON 1	Back up switch position to apply d-c power to solenoid valve of No. 1 cyclic accumulator, manually controlling oxygen flow to accumulator. Removes power from both solenoid valves, shutting off oxygen flow to either accumulator.	ECS - H ₂ O ACCUM-MN A (MDC-22)	D-C main bus A		Switch position is momentary to preclude possibility of expending oxygen needlessly. Switch may be operated when convenient or when suit circuit humidity level becomes uncomfortable.
	Off (center)					
	ON 2	Back up switch position to apply d-c power to solenoid valve of No. 2 cyclic accumulator, manually controlling oxygen flow to accumulator.	ECS - H ₂ O ACCUM-MN B (MDC-22)	D-C main bus B		This switch position is momentary to preclude possibility of expending oxygen needlessly. Switch may be operated when convenient or when suit circuit humidity level becomes uncomfortable.
	WASTE H ₂ O T ₁ REFILL switch		POT H ₂ O HTR MN B (MDC-22)			Switch positions are not momentary; therefore, water quantity indicators must be monitored to prevent overflowing. Potable tank will fill first, unless POTABLE TANK INLET valve is closed. Flow is at the rate of 2.92 lb per minute.
	1	Applies d-c power to solenoid valve of S/M water tank No. 1, permitting water flow to refill C/M water tanks.				
	OFF	Removes power from both solenoid valves.				
	2	Applies d-c power to solenoid valve of S/M water tank No. 2, permitting water flow to refill C/M water tanks.				

MAIN DISPLAY CONSOLE - PANEL 13

SM2A-03-SC012
APOLLO OPERATIONS HANDBOOK

CONTROLS AND DISPLAYS

Location	Name and Position	Function	Circuit Breaker	Power Source	Telemetry Code No. and Identity	Remarks
MDC-13 (Cont)	SUIT EVAP switch AUTO	Applies a-c power to the following to automatically regulate suit circuit temperature by the water-glycol or water evaporation cooling modes: a. Suit evaporator wetness control unit b. Steam pressure control unit c. Diverter valve control unit. Removes a-c power from the following to permit manual override operation of SUIT EVAP GLYCOL valve (LHEB-314): a. Suit evaporator wetness control unit b. Steam pressure control unit c. Diverter valve control unit.	ECS- GLYCOL PUMPS - AC 1 ØB (MDC-22)	A-C bus No. 1	None	The AUTO position must be selected in conjunction with the use of the SUIT HT EXCH switch (LHEB-310). The control unit temperature sensor is located in the suit evaporator outlet. The suit temperature indicator sensor, however, is located at the suit heat exchanger outlet duct. The MAN position is selected in event of failure of any automatic control unit.
	MAN					
	H ₂ O IND switch POT WASTE	Selects potable water tank quantity signal for display on WATER-QUANTITY indicator (MDC-13). Selects waste water tank quantity signal for display on WATER-QUANTITY indicator.	ECS- TRANS- DUCER - WASTE & POT H ₂ O - MNA M1B (MDC-22)	D-C main buses A and B		WATER-QUANTITY indicator is shared by two quantity signals.
GLYCOL EVAP switches H ₂ O FLOW switch AUTO	a. Applies a-c power to water control section. b. Closes circuit from control section to water control valve for automatically regulating water inflow to water-glycol evaporator. Removes a-c power from water control section and d-c power from water control valve.	ECS - GLYCOL PUMPS - AC 1 ØC (MDC-22)	A-C bus No. 1		Water control valve is solenoid-operated.	
	Off (center)					

MAIN DISPLAY CONSOLE - PANEL 13

SM2A-03-SC012
APOLLO OPERATIONS HANDBOOK

CONTROLS AND DISPLAYS

Location	Name and Position	Function	Circuit Breaker	Power Source	Telemetry Code No. and Identity	Remarks
MDC-13 (Cont)	ON	Manual backup mode to apply d-c power to solenoid-operated water control valve, which opens valve and permits water to enter water-glycol evaporator.	ECS - POT H ₂ O HTR MN A MN B (MDC-22)	D-C main buses A and B	None	This switch position is not momentary. Close coordination between switch actuation and the GLY EVAP-OUTLET TEMP indicator (MDC-13) is necessary to obtain correct water-glycol temperature and/or to prevent flooding the evaporator.
	STEAM PRESS group AUTO/MAN switch AUTO	<p>a. Removes a-c power from GLYCOL EVAP - STEAM PRESS - INCR/DECR switch (MDC-13).</p> <p>b. Applies a-c power to steam pressure control section.</p> <p>c. Closes circuit from control section to steam pressure control valve to automatically regulate pressure in steam duct.</p>	ECS- GLYCOL PUMPS- AC 1 ØC (MDC-22)	A-C bus No. 1		Steam pressure control valve full-travel requires 58 seconds (max).
	MAN	<p>a. Removes a-c power from steam pressure control section.</p> <p>b. Opens circuit from control section to steam pressure control valve.</p> <p>c. Applies a-c power to GLYCOL EVAP-STEAM PRESS-INCR/DECR switch.</p>				This switch position selects manual backup mode, permitting manual operation of steam pressure control valve actuator in event of steam pressure control section malfunction.
	INCR/DECR switch INCR	Applies a-c power to actuator of steam-pressure control valve, which moves valve in the closed direction and increases the steam duct pressure.				This switch position is momentary. Until motor-driven steam-pressure control valve reaches its maximum limit, short periods of switch activation result in proportional increases in steam duct pressure. Valve full-travel requires 58 seconds (max).
	Off (center)	Removes a-c power from valve actuator.				

MAIN DISPLAY CONSOLE - PANEL 13

SM2A-03-SC012
APOLLO OPERATIONS HANDBOOK

CONTROLS AND DISPLAYS

Location	Name and Position	Function	Circuit Breaker	Power Source	Telemetry Code No. and Identity	Remarks
MDC-13 (Cont)	DECR	Applies a-c power to actuator of steam pressure control valve, which moves valve in the open direction and decreases the steam duct pressure.	ECS- GLYCOL PUMPS- AC 1 ØC (MDC-22)	A-C bus No. 1	None	This switch position is momentary. Until motor-driven steam pressure control valve reaches its maximum limit, short periods of switch activation result in proportional decreases in steam duct pressure. Valve full-travel requires 58 seconds (max).
	TEMP IN switch AUTO	Applies a-c power to water-glycol temperature control unit, which automatically regulates temperature of coolant entering evaporator by mixing hot and cold water-glycol.	ECS- GLYCOL PUMPS- AC 1 ØA (MDC-22)			Temperature control unit sensor is located at inlet to water-glycol evaporator. Water-glycol evaporator temperature control valve full travel requires 37.5 seconds (max).
	MAN	Removes a-c power from water-glycol temperature control unit, permitting manual override operation of GLYCOL EVAP TEMP IN valve (LHEB-311) by T-handle tool.				Manual control of water-glycol evaporator temperature control valve is required in event of failure of automatic control unit. Close coordination between valve adjustments and GLY EVAP-OUTLET TEMP and ECS RAD-OUTLET TEMP indicators (MDC-13) is necessary to obtain correct water-glycol temperature.
	CABIN TEMP controls AUTO/MAN switch AUTO	Applies a-c power to cabin temperature control unit to automatically regulate temperature of water-glycol flow through cabin heat exchanger.	ECS- CABIN AIR FAN 2 ØC (MDC-22)	A-C bus No. 2		Temperature control unit sensor is located at inlet to cabin air fans; also, an anticipator (sensor) is located at outlet of cabin air fans. Cabin temperature control valve full travel requires 25 seconds (max).
	MAN	Removes a-c power from cabin temperature control unit, permitting manual override operation of the CABIN TEMP control valve (LHFEB-303) by properly positioning control knob.				Manual control of cabin temperature control valve is required in event of failure of automatic control unit. There is a definite time lag in cabin temperature response following a manual adjustment; therefore, close coordination between manual adjustments and the TEMP-CABIN indicator (MDC-13) is not necessary.

MAIN DISPLAY CONSOLE - PANEL 13

SM2A-03-SC012
APOLLO OPERATIONS HANDBOOK

CONTROLS AND DISPLAYS

Location	Name and Position	Function	Circuit Breaker	Power Source	Telemetry Code No. and Identity	Remarks
MDC-13 (Cont)	AUTO control INCR (upward)	Thumbwheel permits manual adjustment of cabin temperature automatic control unit. The higher the number selected, the greater proportional increase in cabin temperature.	None	None	None	Cabin temperature can be selected between 70° and 80°F. Numbers on thumbwheel do not correspond to any temperature.
	COMP FAIL light	Indicates AGC malfunction.	G&N - COMPUTER MN A MN B (MDC-22)	D-C main buses A and B	None	Request for operator to press KEY RLSE pushbutton.
AGC DSKY panel	Internal AGC program needs DSKY circuits to continue program.					
MDC-14	KEY RLSE light	Controls acceptance of telemetered data from MSFN.				
	UPTL switch	Allows AGC to accept data from MSFN.				
	ACCEPT	Inhibits AGC reception of MSFN data.				
	BLOCK	Indicates activity the computer is presently engaged in.				
	ACTIVITY lights	AGC is receiving data link information by telemetry.				
	UPTL	AGC is engaged in computation.				
	COMP	A two-digit display indicating the number of the program (major mode) presently in progress.				
	PROGRAM indicator	A two-digit display indicating verb code selected.				
	VERB indicator	A two-digit display indicating noun code selected.				
	NOUN indicator	Displays contents of selected register or memory location. First component of extended-length data word, if applicable.				
REGISTER 1 indicator						On-board data provides definition of PROGRAM, NOUN, and VERB digits.
					GG5021X (AGC alarm 2)	
					None	Displays may be selected manually or by AGC program.

MAIN DISPLAY CONSOLE - PANELS 13 AND 14

SM2A-03-SC012
APOLLO OPERATIONS HANDBOOK

CONTROLS AND DISPLAYS

Location	Name and Position	Function	Circuit Breaker	Power Source	Telemetry Code No. and Identity	Remarks
MDC-14 (Cont)	REGISTER 2 indicator	Displays contents of selected register or memory location. Second component of extended-length data word, if applicable.	G&N COMPUTER MN A MN B (MDC-22)	D-C main buses A and B	None	Displays may be selected manually or by AGC program.
	REGISTER 3 indicator	Displays contents of selected register or memory location. Third component of extended-length data word, if applicable.				
	BRIGHTNESS control	Varies brightness of electro-luminescent data displays: REGISTER 1, REGISTER 2, and REGISTER 3.				
	KEY RISE pushbutton	Enables program control of DSKYs. Releases operator control of DSKY circuits.				
	ERROR RESET pushbutton	Resets alarm light relays. AGC recycles to start of current operation.				
	Keyboard switches	Provide for entering data into or commanding operation of the AGC.				
	CLEAR	Place all zeros (logic 0s) in register being loaded.				
	VERB	Sets computer to accept next two digits as verb code.				
	NOUN	Sets computer to accept next two digits as noun code.				
	ENTER	Transfers contents of input register to central processor and initiates execution of instructions.				
+	Denotes data to follow has positive decimal value.					
-	Denotes data to follow has negative decimal value.					
0 to 9	Enters the binary equivalent of the key pressed.					
						Verflicet alarms. Alarms triggered by transients should not repeat.
						Pushbutton-type switches (selectors). Each key generates a specific 5-bit key code denoting the instruction or number being selected.

MAIN DISPLAY CONSOLE - PANEL 14

APOLLO OPERATIONS HANDBOOK

CONTROLS AND DISPLAYS

Location	Name and Position	Function	Circuit Breaker	Power Source	Telemetry Code No. and Identity	Remarks
MDC-15	H ₂ PURGE LINE HTR switch					
	ON	Applies +28 vdc power to two 2-watt heaters in fuel cell H ₂ vent line.	FUEL CELL 1 - PURGE and FUEL CELL 2 - PURGE (MDC-22)	D-C main buses A and B	None	Two-position double-pole toggle switch provides heater power during H ₂ purge of fuel cells. Positioned to ON 30 min before H ₂ purge.
	OFF	Remove +28 vdc power from heaters.				Positioned to OFF after completing H ₂ purge.
	HELIUM 1 switches	Four functionally identical switches. Each switch controls one helium isolation valve in the HELIUM 1 half of a parallel helium pressurization system. Each of the four RCS packages contains identical systems.	RCS-PROP ISOL MN A MN B (MDC-25)			Each switch is a three-position toggle switch, spring-loaded, causing it to return to the center position after setting it to the ON or OFF position. Each valve contains a position micro-switch which completes the circuit for operating the valve position event indicator mechanism. Each valve also contains an open and close mechanical latching feature.
	A (B, C, D)	Energizes helium isolation valve solenoid that drives the valve to the open position.				
	ON	Removes solenoid excitation; valve remains in last commanded position.				
	Center	Energizes helium isolation valve solenoid that drives the valve to the closed position.				
	OFF					

MAIN DISPLAY CONSOLE - PANEL 15

APOLLO OPERATIONS HANDBOOK

CONTROLS AND DISPLAYS

Location	Name and Position	Function	Circuit Breaker	Power Source	Telemetry Code No. and Identity	Remarks
MDC-15 (Cont)	<p>HELIUM 1 event indicators A (B, C, D)</p> <p>HELIUM 2 switches</p> <p>A (B, C, D)</p> <p>ON</p> <p>Center</p> <p>OFF</p> <p>HELIUM 2 event indicators A (B, C, D)</p> <p>PROPELLANT switches</p>	<p>Striped-line display indicates closed condition of valve controlled by switch located directly above event indicator. Gray display indicates open condition.</p> <p>Four functionally identical switches. Each switch controls one helium isolation valve in the HELIUM 2 half of a parallel helium pressurization system. Each of the four RCS packages contain identical systems.</p> <p>Energizes helium isolation valve solenoid that drives the valve to the open position.</p> <p>Removes solenoid excitation; valve remains in last commanded position.</p> <p>Energizes helium isolation valve solenoid that drives the valve to the closed position.</p> <p>Striped-line display indicates closed condition of valve controlled by switch located directly above event indicator. Gray display indicates open condition.</p> <p>Four functionally identical switches. Each switch controls two isolation valves (one fuel, one oxidizer) within each of the four S/M RCS packages.</p>	<p>RCS-PROP ISOL MIN A MIN B (MDC-25)</p>	<p>D-C main buses A and B</p>	<p>None</p>	<p>Each indicator is a two-position device with striped-line display controlled by solenoid action and gray display by permanent magnet action.</p> <p>Each switch is a three-position toggle switch, spring loaded, causing it to return to the center position after placing it to the ON or OFF positions. Each valve contains a position microswitch which completes the circuit for operating the valve position event indicator mechanism. Each valve is mechanically latched open and spring-loaded closed.</p> <p>Each indicator is a two-position device with striped-line display controlled by solenoid action and gray display by permanent magnet action.</p> <p>Each switch is a three-position toggle switch, spring-loaded, causing it to return to the center position after placing it to the ON or OFF positions. Each valve contains a position microswitch which completes the circuit for operating the valve position event indicator. Each valve is magnetically latched open and spring-loaded closed.</p>

MAIN DISPLAY CONSOLE—PANEL 15

SM2A-03-SC012
 APOLLO OPERATIONS HANDBOOK

CONTROLS AND DISPLAYS

Location	Name and Position	Function	Circuit Breaker	Power Source	Telemetry Code No. and Identity	Remarks
MDC-15 (Cont)	A (B, C, D) ON	Energizes propellant isolation valve solenoids that drive two valves to the open position.	RCS-PROP ISOL MN A MN B (MDC-25)	D-C main buses A and B	None	
	Center	Removes solenoid excitation; valves remain in last commanded position.				
	OFF	Energizes propellant isolation valve solenoids that drive two valves to the closed position.				
	PROPELLANT event indicators A (B, C, D)	Striped-line display indicates closed condition of valves controlled by switch located directly above event indicator. Gray display indicates open condition.				Each indicator is a two-position device with striped-line display controlled by solenoid action and gray display by permanent magnet action. Indicator will function (striped-line display) if either valve is in a closed position.
	C/M-S/M SEP switches Switch 1 and 2 Up	Activates systems A and B to perform the following functions: a. C/M-S/M deadface b. C/M-RCS pressurize c. C/M-S/M separation d. Transfer entry batteries to d-c main buses A and B e. C/M-S/M separation pyro control shut-off f. RCS control transfer g. C/M-S/M separation signal to SMJC. Off position.	MASTER EVENT SEQ CONT A ARM B BAT A and BAT B (MDC-22)	Battery buses A and B	CD0023X CM-SM separate relay close A CD0024X CM-SM separate relay close B	The switches are spring-loaded to the down position. The two switches are guarded redundant switches.
	Down C/M RCS PRPLNT group	Two functionally identical switches. Each switch controls two isolation valves (one fuel, one oxidizer) within its respective propellant system.	RCS-PROP ISOL MN A MN B (MDC-25)	D-C main buses A and B		Each switch is a three-position switch. Switch is spring-loaded from the OFF position to center position only. Each valve contains a position microswitch which completes the circuit for operating the valve position-event indicator mechanism. Each valve also contains an open and close latching feature.

MAIN DISPLAY CONSOLE - PANEL 15

SM2A-03-SC012
APOLLO OPERATIONS HANDBOOK

CONTROLS AND DISPLAYS

Location	Name and Position	Function	Circuit Breaker	Power Source	Telemetry Code No. and Identity	Remarks
MDC-15 (Cont)	A (B) switch	Energizes propellant isolation valve solenoids that drive two valves to the open position.	RCS-PROP ISOL MN A MN B (MDC-25)	D-C main buses A and B	None	Each indicator is a two-position device with striped-line display controlled by solenoid action and gray display by permanent magnet action. Indicator will function (striped-line display) if either valve is in a closed position.
	ON	Removes solenoid excitation; valves remain in last commanded position.				
	Center	Energizes propellant isolation valve solenoids that drive two valves to the closed position.				
	OFF	Striped-line display indicates closed condition of valves controlled by switch located directly above event indicator. Gray display indicates open condition.				
MDC-16	ELS switch	a. Prepares ELS for automatic enabling during LES abort. b. Allows the ELS to function automatically during descent of C/M. Disconnects logic arming circuitry from ELS controller.		MESC logic bus through Z12 ELS activate relays	None	Normal position of switch. Switch is set to the MAN position after drogue parachute deployment during an abort initiated prior to 61 seconds after lift-off. The main parachutes must be deployed manually with the MAIN DEPLOY pushbutton (MDC-5) after the switch is set to the MAN position. If the main parachutes are deployed manually, the MAIN DEPLOY-AUTO switch must be set back to AUTO to allow 14-second timer to enable parachute release after touchdown.
	AUTO MAN					

MAIN DISPLAY CONSOLE—PANELS 15 AND 16