

# Simulation Framework for a Mobile Ad-Hoc Network

**Jean-Sebastien Pegon and Madhavi W. Subbarao**

Wireless Communications Technology Group  
National Institute of Standards and Technology  
100 Bureau Drive Stop 8920  
Gaithersburg, MD 20899  
[jspigon@antd.nist.gov](mailto:jspigon@antd.nist.gov) and [subbarao@nist.gov](mailto:subbarao@nist.gov)

## Abstract

Using OPNET a general framework has been developed to test MANET routing efficiency for different physical layers, network topologies, and nodal mobilities. With OPNET it is possible to design different physical layers, MAC layers, and routing schemes, to compare end-to-end statistics (end-to-end delay, throughput and power consumption), and finally to determine the most efficient solution.

## I. Introduction

A mobile ad hoc network (MANET) is an autonomous collection of mobile users (nodes) that communicate over bandwidth-constrained wireless links. Due to nodal mobility, the network topology may change rapidly and unpredictably over time. The network is decentralized, where network organization and message delivery must be executed by the nodes themselves. However, message routing in a decentralized environment where the topology fluctuates is not a well-defined problem. While the shortest path from a source to a destination based on a given cost function in a static network is usually the optimal route, this idea is not easily extended to MANETs. Factors such as power expended, variable wireless link quality, propagation path loss, fading, multi-user interference, and topological changes, become relevant issues. The network should be able to adaptively alter routing paths to alleviate any of these effects.

In this paper, we develop a general framework for executing routing in a MANET in various channel conditions. Two forms of routing for a MANET include hop-by-hop myopic routing and end-to-end source routing. In both cases, routing decisions are made based on dynamic link cost functions. The framework developed herein provides a mechanism to evaluate and design different link cost metrics.

We consider a direct-sequence spread-spectrum MANET using the basic ALOHA random access protocol. We

employ BPSK signaling, adaptive transmission power allocation, and a simple Rayleigh fading model. This paper is organized as follows. In section II, we provide a description of the two routing approaches: myopic routing and source routing. In section III, we describe the simulation environment including the network and node models. In section IV, we present our simulation model for direct-sequence spread-spectrum modulation. In section V, we describe our simple Rayleigh fading model. Finally, in section VI, we present simulation results and a conclusion.

## II. Routing Approaches

In the general simulation framework, we implement with OPNET two different routing approaches for MANETs: hop-by-hop myopic routing and end-to-end source routing.

- Myopic Routing: Each node only determines the next hop a packet should take toward its final destination. A node must determine which nodes are within transmission range, and then determine the "best" neighbor who can forward the packet toward the destination. While all nodes within transmission range will receive the packet, only the chosen neighbor must forward the packet. The chosen neighbor is selected according to a given link cost metric.
- Source Routing: The entire route of a packet is determined at the source node using the shortest path routing with given link cost metrics. A periodically updated table stores the routes to reach each destination.

Myopic routing is a reactive, hop-by-hop routing scheme, while source routing is a proactive, end-to-end routing approach. It is interesting to study how these routing schemes will behave in our global framework and to compare their performances via different metrics. With the framework provided, it

will be easy to define and test different link cost models for both approaches.

### III. Simulation Environment

In this section we present the general framework developed to simulate a MANET environment. As no final standards have been chosen for the different MANET layers, this framework provides a convenient method to test and compare different layer choices.

#### A. Network Model

The network comprises N mobile nodes, named 0,...,N-1, that communicate over wireless links. For simplicity and to guarantee a reliable radio channel during the movement of the nodes, the topology is chosen such that nodes reside on one of three levels.

\*\*\*\*\*

the topology is simple : 3 levels ( y = 1,3,5). The nodes of different level can move on straight lines (y = 1,3,5 for x ∈ [0,7]).

\*\*\*\*\*

A variation of the moving speed implies a variation of the network topology and allows us to measure the mobility of the network. Figure 1 represents the network model.

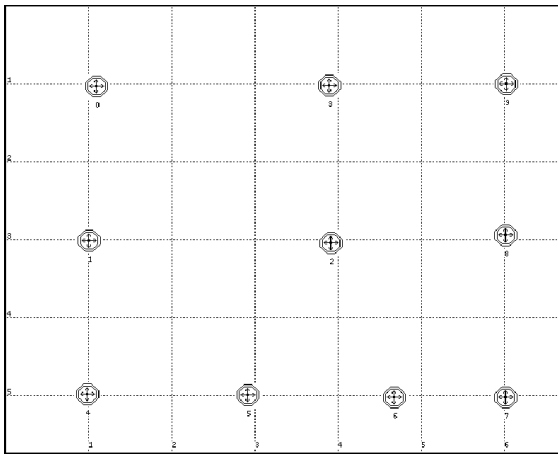

Figure 1 - Network model with unit scale in kilometers

The transmission range is chosen and depends on the network topology.

#### B. Node Model

Each of the 10 nodes has the structure given in Figure 2 and is uniquely identified by its user ID.

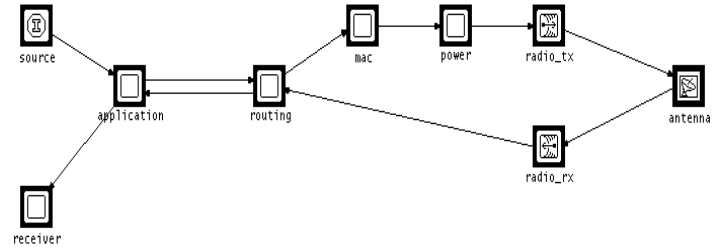

Figure 2 – Mobile Node Model

- The *source* module generates packets according to an interarrival exponential distribution. This interarrival time can be chosen during the simulation. The packet size is 100 bits and the packet format has six fields as shown in Figure 3: destination and next node address which contain the destination name and next node name respectively, power field which stores the transmitted power, hop field which memorizes the path of the packet, fading field which depends on the fading factor of the link, and the data field.

Destination	Next node	Power
Hop	Fading	Data

Figure 3 – Data Packet Fields

- The *application* module sets a random destination address to the incoming packet and measures the number of total packets transmitted.
- The *routing* module executes both routing approaches, myopic and source routing. Various link cost metrics can be tested and compared for both routing approaches.
- The *MAC* module is used to simulate the random access channel protocol. In this simulation, a simple ALOHA has been used. Other MAC layer protocols such as CSMA/CD, 802.11 or FAMA can be tested.
- The *power* module processes the spreading code allocation and estimates an optimum transmission power for each new packet. This module illustrates simulation of the physical layer and is described in more detail in the remainder of the paper.
- The *radio\_tx* module sends the packets on the radio channel through the antenna. The modulation is BPSK with spread spectrum.

- The *antenna* module sends and receives packets from the defined channel. The antenna is an isotropic pattern.
- The *radio\_rx* module receives packets from the antenna.
- The *receiver* module records various end-to-end statistics and destroys the packets.

#### IV. Direct-Sequence Spread-Spectrum

With OPNET it is possible to simulate direct-sequence spread-spectrum communication in a simplistic way. Using the mechanisms provided by OPNET, we assign a different spreading code for each node in the network. Before transmitting a packet we determine the spreading code of the intended receiver and transmit the packet using this code. Even if the intended node receives a packet, multi-user interference is created on the channel. This spread-spectrum effect is not simulated in this simple model.

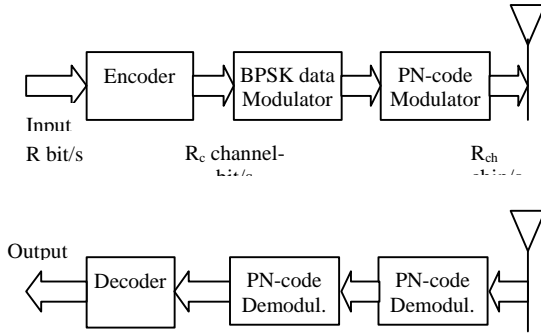

Figure 4 : Physical layer scheme

Consider the physical layer design shown in Figure 4. It is important to understand the different pipeline stages of the channel simulation in order to choose a « level » of simulation. Since the default OPNET model does not allow us to simulate the whole modulation process, we have chosen to simulate the channel at the chip level. Consequently, the channel characteristics are set up at the chip level. The chip rate (9.6Gchip/s) is the inverse of the bandwidth, e.g., packet size of 100 bits is equal to 100 Kchips. The processing gain is set to 30 dB. With the characteristics chosen in this manner, the SNR at the receiver is then at the *chip* level. However, the requirements are at the *bit* level for the bit-error rate. Consequently, we must determine how to compute the bit error rate knowing the SNR at the chip level.

#### A. Theoretical study

According to our model, OPNET provides the SNR at the *chip* error rate:  $\frac{E_{ch}}{N_o}$ . We have the following relation between the SNR at the chip level and the SNR at the channel level:

$$\frac{E_{ch}}{N_o} * R_{ch} = \frac{E_c}{N_o} * R_c,$$

and we have also

$$R = \frac{k}{n} * R_c \Leftrightarrow R_{ch} = G * \frac{k}{n} * R_c \text{ where } G = \frac{R_{ch}}{R}.$$

We deduce the desired relation of the SNR at the channel level:

$$\frac{E_c}{N_o} = \frac{E_{ch}}{N_o} * G * \frac{k}{n}. \quad (1)$$

With this relation, it is then possible to use OPNET's modulation table for BPSK to determine the channel bit

error probability  $p_c$ :  $p_c = Q\left(\sqrt{\frac{2E_c}{N_o}}\right)$ .

Finally we can compute the bit error probability:

$$p_b = \frac{1}{n} \sum_{j=t+1}^n j * C_j^n * p_c^j (1 - p_c)^{n-j}, \quad (2)$$

where  $t$  is the number of recoverable errors, e.g.,  $t=2$  for a (61,53) code.

#### B. Implementation

With the aforementioned modifications, it is now possible to pass from the chip SNR to the max BER threshold called "ECC threshold" in OPNET. We modified the BER pipeline stage according to Equation (1) in order to obtain the channel bit error probability as an output. We modified the « dra\_ber » pipeline stage file by adding the term  $k/n$  in the effective SNR. Then we recompiled the new file « ber\_bpsk » using the op\_mko OPNET command.

The ECC threshold should then be chosen at the channel level, and the computation from equation (2) performed by the user. In this case, the code allows  $t=2$  errors every 63 bits, which means 3% errors at the bit level. According to equation (2), this corresponds to 5% errors at the channel level. Hence, we set the OPNET ECC threshold to 0.05.

This is the solution we use to simulate direct-sequence spread-spectrum at the channel level. In the simulation section, we compare the characteristics of this channel with a channel without direct-sequence spread-spectrum modulation.

### V. Fading Simulation

In this section, we present a simple way to simulate a fading effect in a MANET as shown in Figure 5. We assume that each wireless link has the same fading factor for a period  $\tau$  seconds, which depends on how fast the fading is changing.

To implement this phenomenon, we define a *fading table* of size  $(N*N)$ , where  $N$  is the number of nodes in the network. Each entry  $(i, j)$  represents the fading factor between node  $i$  and node  $j$ . In the Initialization State, we compute a random fading factor according to the Rayleigh distribution for each link. The table is updated every  $\tau$  seconds by recomputing new fading factors.

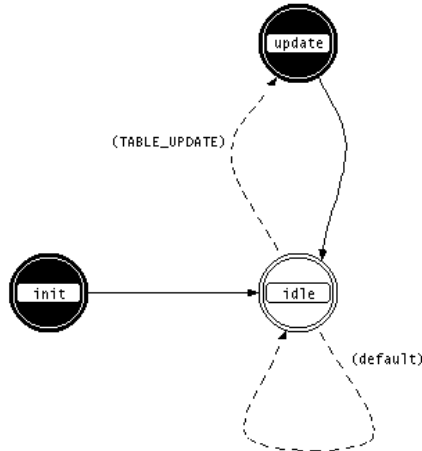

Figure 5 - Fading process

For every packet, the “fading field” is set to the value corresponding to the wireless link on which it will be transmitted. We modified the *power* pipeline stage so that the received power is multiplied by the fading factor retrieved from the packet header. The interval time  $\tau$  and the variance of the Rayleigh fading process can be chosen at the beginning of the simulation according to the type of fading to be simulated (slow or fast fading).

### VI. Performance Metrics and Simulation Results

In order to evaluate the performance of different routing protocols for MANET, we need to consider different quantitative metrics. Indeed the characteristics of a MANET imply that we have to take into account more

factors. In this global simulation framework, we compute the following statistics:

- end-to-end delay
- end-to-end throughput
- efficiency
- mean transmitted power per packet
- mean transmitted power per hop
- number of hops in the packet path
- distance of the packet path
- amount of overhead

#### \*\*\* Include Simulation Results \*\*\*

- Comparison between the two channel model (simple one and SS-DS).
- Comparison between myopic and source routing.

### Conclusion

Extra Text:

In myopic routing, a routing decision is made by each node along a path to the final destination. In contrast, in source routing all routing decisions are made at the source node and the entire path is stored in the header of the packet. The type of routing that is more suitable for a given network depends on the dynamic network conditions.