



Automotive System Cost Modeling Tool (ASCM)

Center for Transportation Analysis (CTA) Research Areas

Aviation Safety
Air Traffic Management Analysis
Data, Statistical Analysis
Geo-Spatial Information Tools
Defense Transportation
Energy Policy Analysis
Environmental Policy Analysis
Highway Safety
Intelligent Transportation Systems
Logistics Management
Supply Chain Management
Modeling and Simulation
Transportation Operations
Planning and Systems Analysis
Transportation Security

Patricia S. Hu, Director
Center for Transportation Analysis
Oak Ridge National Laboratory
2360 Cherahala Boulevard
Knoxville, TN 37932
865.946.1349
(Fax) 865.946.1314
Website: cta.ornl.gov

The affordability of today's and future advanced technology vehicles (i.e., diesel, hybrid, and fuel cell)

developed for improved fuel economy remains a concern with respect to final consumer acceptance. The latest federal government cooperative research and development program, i.e., Freedom Cooperative Automotive Research (FreedomCAR) has also been focusing on hydrogen-powered fuel cell vehicles and technology development applicable across a wide range of vehicle platforms. This has been done without any specific fuel economy goals where vehicle affordability is also a concern. It is



not clear how technical targets developed at the component level, will translate to vehicle manufacturing cost and also life cycle cost.

The Automotive System Cost Model (ASCM), jointly developed by Oak Ridge National Laboratory and Ibis Associates, Inc. is a tool for vehicle

life cycle cost estimation at a resolution of major vehicle components for advanced class vehicles and systems.

The Cost Model

ASCM estimates the vehicle life cycle cost at a level of five major subsystems (powertrain, chassis, body, interior, and electrical) and more than thirty-five components representing a specific manufacturing technology. Then vehicle operation costs are added for the vehicle life cycle cost estimation. The interrelationships among vehicle subsystems and their effect on vehicle manufacturing cost are also considered. The main objective of this model is to facilitate relative life cycle cost estimation via a uniform estimation methodology to allow comparison of alternative technologies considered by the FreedomCAR community.

Any one of the 13 light-duty EPA vehicle classes can be considered for the life cycle cost estimation of advanced technology vehicles:

- Two-seater,
- Minicompact,
- Subcompact,
- Compact,
- Midsize,
- Large Passenger Car,

Automotive System Cost Model

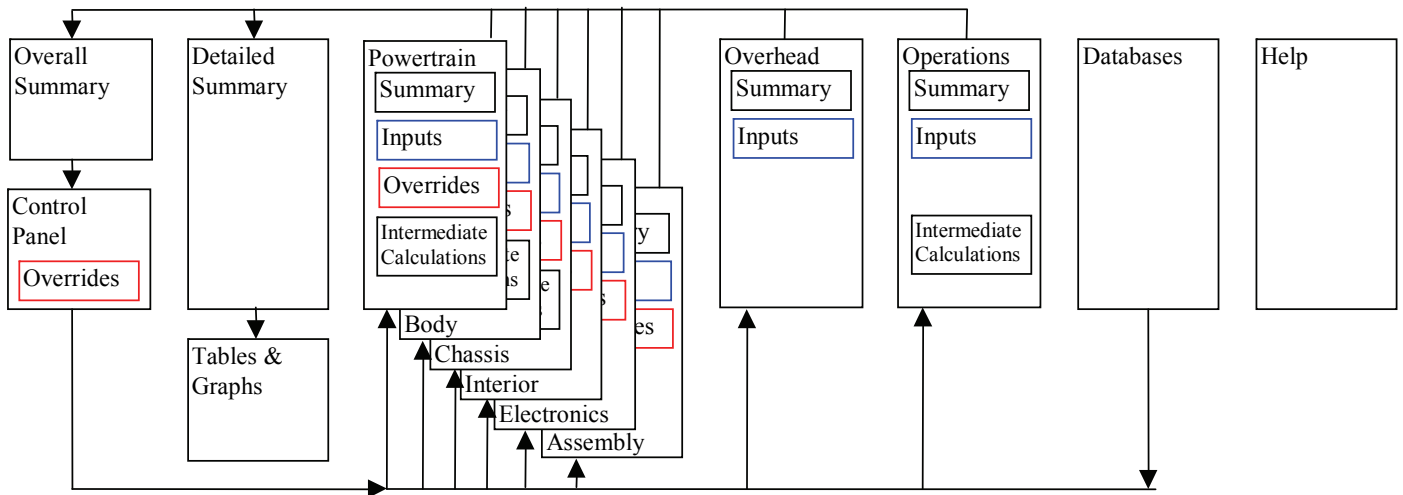

- Small Truck,
- Standard Truck,
- Full Cargo Van,
- Minivan,
- Small SUV,
- Midsize SUV, and
- Large SUV.

Powertrain component sizing can either be done through Argonne National Laboratory's hybrid vehicle cost model algorithm (adapted into the model) or by directly inputting in the model the sizing information obtained from the performance model Powertrain Systems Analysis Toolkit (PSAT). The non-powertrain components are sized based on their functional relationships with powertrain components. Operating costs such as financing, insurance, local fees, fuel, maintenance, repair, and disposal costs are considered in estimating the life cycle cost per vehicle, as well as per vehicle mile traveled. The database is designed to be dynamic, providing a centralized source of cost data for alternative technologies of advanced vehicle designs and concepts as they become available.

Capabilities of the Tool

The cost model provides:

- Baseline cost structure of 13 specific EPA

- light-duty vehicle classes,
- Benchmarking of cost of commercial vehicles in the market,
- Cost target analysis (system level target impacts on vehicle cost),
- Relative competitiveness of vehicle component technologies (body-in-white lightweighting vs. fuel cell powertrain), and
- Centralized repository of component level cost data of developmental technologies for advanced vehicles.

Sample Questions the Tool Can Help Answer

- What is the life cycle cost of today's midsize hybrid vehicle?
- How does the life cycle cost of today's advanced vehicles compare with those expected in 2010 if DOE component level technical targets are met?
- Which vehicle components are affecting the affordability of advanced vehicles?
- Which particular component technology should be prioritized for further research and development?
- What is the cost of high power batteries today?

For more information regarding this research contact Sujit Das, Center for Transportation Analysis, Oak Ridge National Laboratory, phone (865) 946-1222 or email dass@ornl.gov.