

RECLAMATION

Managing Water in the West

High Lakes Stabilization Swift Creek Drainage Lakes Technical Memorandum

Uinta Basin Replacement Project



U.S. Department of the Interior
Bureau of Reclamation
Provo Area Office
Provo, Utah

June 2006

High Lakes Stabilization Swift Creek Drainage Lakes Technical Memorandum

Uinta Basin Replacement Project

prepared by

**Provo Area Office
Upper Colorado Region**



**U.S. Department of the Interior
Bureau of Reclamation
Provo Area Office
Provo, Utah**

June 2006

Concurrence

The undersigned concur with the recommendations identified in this Technical Memorandum. This Technical Memorandum will serve as a Decision Memorandum.

Jerry Olds P.E. Date
Utah State Engineer

Reed R. Murray Date
Department of the Interior
CUPCA Office

Jack Troyer Date
Regional Forester
U.S. Forest Service

Michael C. Weland, Executive Director Date
Utah Reclamation Mitigation and Conservation Commission

Contents

	Page
Introduction	1
Design Considerations	4
Water Lily Lake	4
Inflow Hydrology.....	4
Dam Break Analysis	5
Outlet Works.....	5
Spillway	5
Recommendations.....	6
Farmers Lake	7
White Miller Lake.....	8
Appendix A - Memorandum of Understanding	9
Appendix B - Drawings	10
Appendix C - Inflow Hydrology Output Files.....	11
Appendix D – Construction Quantities.....	12
Appendix E – Dam Break Output Files	13

Introduction

The Uinta Basin Replacement Project (UBRP Project) was authorized by Section 203 of the Central Utah Project Completion Act [CUPCA: Titles II through VI of P.L. 102-575, as amended]. The UBRP Project is located within Duchesne County near the towns of Altamont, Upalco, and Roosevelt, within the Uinta Basin of northeastern Utah. Its purposes are to increase efficiency, enhance beneficial uses, and achieve greater water conservation within the Uinta Basin. The Central Utah Water Conservancy District (the District) is implementing the water development portions of the UBRP Project, and the Utah Reclamation Mitigation and Conservation Commission (the Commission) is responsible for mitigating project impacts to fish, wildlife and wetland habitats. Funding for mitigation measures is provided under Title II of CUPCA through the U.S. Department of the Interior. The Final Environmental Assessment for the UBRP Project was prepared by the District and was signed by the Department of the Interior in October 2001. Project construction began in 2003. The Commission issued a Decision Notice and Finding of No Significant Impact in February 2004 for implementing fish and wildlife mitigation features of the UBRP Project.

A component of the UBRP Project is that 13 high mountain lakes formerly used to store water rights would be stabilized at No-Hazard levels, and the water rights transferred downstream for storage in the enlarged Big Sand Wash Reservoir, another feature of the UBRP Project. The stabilization of the thirteen reservoirs is mitigation for the enlargement of Big Sand Wash Reservoir. Because of the breach potential of the High Lakes Dams, and the difficulty in monitoring and maintaining these dams in the Wilderness area, the CUP Mitigation Commission is undertaking the stabilization of 13 of these dam structures and replacing the storage water rights downstream in the expanded Big Sand Wash dam where maintenance and monitoring is practical. These wilderness dams vary in size, hazard rating and condition and have peak breach flow potential ranging from hundreds to several thousand cubic feet per second (cfs). Breach flows of this magnitude far exceed the carrying capacity of existing streams and they would cause extensive damage to the downstream forest resource, campgrounds, trails, roads, dams and in some cases, private property and residents. Because of this fact the “Do Nothing” option was not considered appropriate because of the eventuality of the deterioration and catastrophic failure of these dams.

Although there are no absolute criteria for defining a No-Hazard dam, the Utah State Engineer is authorized to make that determination. Section R655-10-5 of The State of Utah Statutes and Administrative Rules for Dam Safety dated July 1996 states “The State Engineer is the ultimate authority on the hazard classification designation for a given dam”. However, the Forest Service also has dam safety responsibilities and the two agencies have outlined a number of

protocols regarding dam safety matters in a memorandum of understanding between the two agencies (attached as Appendix A). Therefore, all decisions and recommendations regarding these structures are mutually agreed to by both parties.

Essentially, the No-Hazard rating is achieved by demonstrating that in the event of failure, there is no appreciable damage or adverse affects downstream of the dam. For the more significant structures, this demonstration is accomplished through a dam break analysis. Various stabilized reservoir elevations are assumed and the resulting flood from a sunny day break is compared to the existing downstream channel capacity. When the reservoir elevation results in a flood that can be contained within the downstream channel, the dam can be considered to be No-Hazard.

Stabilization of the thirteen high mountain lakes at No-Hazard levels will provide constant lake water levels year-round. Nine of these lakes (Bluebell, Drift, Five Point, Superior, Water Lily, Farmers, East Timothy, White Miller, and Deer) are located in the Upper Yellowstone River watershed and four (Brown Duck, Island, Kidney and Clements) are in the Brown Duck Basin of upper Lake Fork watershed. Consequently, streamflows originating in these upper watersheds will return to natural hydrologic runoff patterns, wilderness fishery and recreational values will be restored within the High Uintas, and operation and maintenance impacts will be eliminated in the wilderness area. Construction work in the upper Lake Fork drainage cannot begin until Big Sand Wash Dam is completed and has successfully passed filling criteria (anticipated in 2007).

The thirteen high mountain reservoirs are located in the High Uintas Wilderness Area. The U.S. Forest Service, Moon Lake Water Users Association, U.S. Bureau of Reclamation and Duchesne County Water Conservancy District all have knowledge and experience with operation, maintenance and stabilization of the high mountain lakes. The Commission entered into Interagency Agreement No. 05-AA-UT-1300 with Reclamation to provide engineering, design, construction, and oversight services for the stabilization project. This technical memorandum is a work product under the Interagency Agreement.

Typically, the stabilization of these dams will require the excavation of a spillway notch, with stable side slopes, through the middle of the embankment and the removal of the low level outlet. An armored, stabilized low level channel would then be constructed in the notch to pass normal runoff as well as large storm events without jeopardizing the remaining structure by impounding excess water. In some cases the embankment may be removed or rolled over on itself to decrease the height and increase the stability and ability of the remaining embankment to withstand any seismic event or overtopping during extreme events. This work is the minimum necessary to stabilize these dam structures and

restore natural hydrologic flows to the greatest extent possible, while still meeting a "No Hazard" dam safety rating.

The work to be accomplished in the Swift Creek Drainage Basin is to stabilize Water Lily Lake, plug the Farmers Lake Tunnel, and remove the outlet structure at White Miller Lake. The stated objective for these lakes is to create a dam that is assigned a No-Hazard classification with a minimum design life of 100 years (essentially a permanent fix). In order to achieve a No-Hazard rating, the stabilized dams and associated reservoir levels must be approved by the State Engineer and concurred with by the Forest Service.

An additional constraint is that each individual dam stabilization would need to be completed in one construction season (usually July through September) because of the vulnerability of a partially removed embankment. These partially completed dams could easily overtop and fail from snow melt runoff or storm events, even if the outlet was still in place and open. Breach flow potential would be extensive even from the reduced lake storage volumes. Existing spillways would be too high to assist in flood routing under these circumstances and it would be prohibitive to build auxiliary or temporary spillways over the excavated embankment or on bedrock at the proper level, even if it could be located. It was determined that this risk possibility was inconsistent with the projects goals of safety and stabilization as well as minimum impact and the preservation of the Wilderness resources and values.

As indicated by the concurrence page, the purposes of this memorandum are to document the design decisions and rationale used in the final design and to ensure that each of the participating agencies are in agreement with and approve of the final design. This memorandum separately describes the design for each of the dams to be stabilized in the Swift Creek Basin.

The appendices contain design drawings and backup data that support the design conclusions and recommendations. Appendix B contains design drawings showing location maps and applicable details for each of the three lakes. Appendix C contains portions of the HEC-1 output files for the inflow hydrology that was performed on Water Lily Lake. The total output file for this work contains numerous pages, most of which is hydrograph data that is not necessarily meaningful to most readers. Rather than include the entire output, select pages that contain relevant flow data have been provided. The remaining output will be kept on file and made available upon request. Appendix D contains a summary table of the construction quantities for the designed work. Appendix E contains a summary of the Simplified Dam Break analysis for Water Lily Lake. The total output file for the dam break analysis also contains additional pages which are kept on file and are available upon request.

Design Considerations

For Water Lily Lake there are a number of issues and considerations that must be accounted for in the design. This includes the following:

- Inflow hydrology
- Dam break analysis
- Outlet works removal or plugging with associated cutoffs and filters
- Spillway configuration including width, armoring, and side slopes

For Farmers Lake and White Miller Lake, the modifications required for a No-Hazard classification are minor and extensive analyses are not required. Work at Farmers Lake will consist of plugging the existing tunnel and filling the existing air intake shafts with rock/rubble. Work at White Miller Lake will consist primarily of removing a wooden outlet works structure. Therefore, hydrology and dam break analyses are not warranted for these dams.

Water Lily Lake

Water Lily Lake is located in the Swift Creek drainage about 0.5 miles above the Yellowstone River. It has a surface area of about 15 acres at the existing spillway and holds approximately 71 acre-feet of water. The dam is a homogeneous embankment approximately 9 feet high and has a 24-inch diameter low-level outlet located near the right abutment. The existing outlet works gate is no longer operable or functioning. No formal survey work was performed at Water Lily Lake. Topographical maps indicate the existing spillway elevation is 9,346. The proposed spillway breach inlet is also set to be at elevation 9,346.

Inflow Hydrology

The Water Lily Lake drainage basin is 0.35 square miles in area and is comprised of heavily wooded slopes with small areas of rocky outcrops. The Watershed Modeling System (WMS) software package was used to model the drainage basin using the Digital Elevation Model (DEM) obtained from the USGS web site. Hydrologic characteristics for the basin were then incorporated for full analysis. The 100-year, 6-hour storm estimate of 2.36 inches was obtained from the National Oceanic and Atmospheric Administration's (NOAA) Precipitation Frequency Data Server, Atlas 14, Volume 1, Version 3. This storm has a peak runoff of 41 cfs. However, when routed through the lake, the peak runoff is attenuated to a maximum flow of 9 cfs through the spillway.

The Basin Average method was combined with the U.S. Soil Conservation Service (SCS) Type-II, 24-hour curve to define the series. The SCS curve

number method was used to model the basin losses, with a curve number of 70 (corresponding to AMC II “good” conditions). The SCS method was used within WMS to compute a Lag time of 0.65 hours. The Muskingum-Cunge method was used for stream routing with averaged stream characteristics based on observed conditions. The reservoir area-capacity curve was estimated for routing purposes.

Dam Break Analysis

The Simple Dam Break (SMPDBK) model contained within the WMS package was used to model the dam break scenario. A 5-foot-wide breach was used with a 200 minute time-to-breach. A sunny day break of Water Lily Lake Dam with the spillway at elevation 9,346 produces a maximum flow of 13 cubic feet per second and a water depth in the downstream channel averaging about 0.9 feet. This analysis indicates that little or no effects will occur in the event of a breach in the dam.

Outlet Works

In order to have a No-Hazard classification there can be no operable outlet works. The existing outlet works will be removed and a new spillway channel constructed in its place along the same alignment as the outlet works. The new spillway channel will be excavated to the invert elevation of the existing outlet works. A concrete cutoff will not be required because the new spillway excavation will either be above existing undisturbed ground or on bedrock. The total excavation required would be approximately 160 cubic yards.

A 7-foot wide by 3-feet high by 2-feet deep concrete headwall exists at the end of the outlet works. This headwall will need to be removed for the new spillway construction. The headwall could be broken up into smaller pieces by controlled blasting, cutting, or other methods as directed and approved in the field.

The existing outlet works pipe will be disposed of based on conditions encountered in the field. As directed by the Forest Service, the pipe will be either buried on site or removed and disposed of at an appropriate location. If the pipe is buried on site, it will be flattened as much as possible to minimize the depth and area of the required excavation. If the pipe is removed from the site, no matter what method is used it will likely require cutting into smaller more manageable lengths.

Spillway

Based on the results of the dam break analysis and as shown on the drawings, a spillway invert elevation of 9,346 feet would have minimal effects downstream in the event of a sudden breach. It is likely that the spillway elevation could be

raised without appreciable downstream effects during a dam breach. However, to avoid having to place compacted backfill and a concrete cutoff, the spillway elevation will remain at 9,346.

The spillway will be armored with a 1-foot riprap layer along the invert and side slopes. The armoring of the invert and side slopes will provide protection against erosion and will ensure stable and permanent side slopes. If bedrock is encountered during the excavation of the outlet works, riprap would not be required in those areas.

As shown on the drawings, the spillway configuration for this dam has been minimized to the greatest extent possible. The spillway width of 5 feet coupled with 2 horizontal to 1 vertical side slopes was selected to eliminate as much earthwork as possible while still maintaining a functioning spillway. To help reduce the amount of blockage from snow/ice and debris, a 15-foot wide transition entrance to the spillway will be constructed.

The downstream end of the spillway will be provided with a rock cutoff that will prevent headcutting and erosion of the spillway channel and transition into the existing outlet channel.

The 100 year Storm Spillway Hydraulics table in Appendix C provides 100 year storm hydraulic data for the spillway flows for each of the dams.

Recommendations

Based on the information available, it is recommended that the outlet works pipe be completely removed. A spillway that requires a minimal amount of earthwork should be constructed along the same alignment as the outlet works. The inlet to the spillway will be in the same location as the existing outlet works inlet. The new spillway will have a grade of approximately 6.35 percent, equal to the existing outlet works grade. It is recommended that the spillway be at least 2 feet deep to ensure that seasonal flooding will be contained within the channel. If no bedrock is encountered, it is recommended the channel be lined with riprap armoring to help control erosion in the spillway. All riprap will extend to the top of the spillway sides. As stated previously, the inlet transition will be constructed to help eliminate potential clogging of the channel. Riprap armoring will be placed within the transition area as well.

Farmers Lake

Farmers Lake is located in the Swift Creek Drainage. The outlet for Farmers Lake is an approximately 4-foot high by 2-foot wide by 180-foot long tunnel which has been excavated through existing rock. The inlet to the tunnel has collapsed with the rock from the ceiling of the tunnel. The inlet requires a 5-foot high by 3-foot wide by 8-inch thick reinforced concrete plug. The total concrete required is approximately 0.7 cubic yards. Rock removal around the inlet will be required to enable construction of the concrete plug in competent rock. In the event that it is not possible to obtain competent rock at the inlet that is suitable for a concrete plug, a contingency plan will be implemented. The inlet to the tunnel will instead be blocked off with rock/rubble in a similar fashion as the tunnel outlet as described below. The concrete plug would be positioned at the inlet or upstream side of the tunnel within the upstream air shaft as shown on the drawings. All other modifications will remain the same.

The tunnel has two air intakes along the length of the alignment which allows access to the tunnel. The upstream air intake is approximately 6.5 feet square and 17 feet deep. The second or downstream air intake is approximately 9 feet long by 5 feet wide and 5 feet deep. The air intakes will be filled with rock/rubble to prevent access into the tunnel and eliminate the existing safety hazard. The total amount of rock/rubble to fill the air intakes is 33 cubic yards. Rock at the top of the fill must be of sufficient size (approximately 1-1/2 to 2 cubic feet but not less than 1 cubic foot) so that it cannot be removed by hand.

The outlet of the tunnel will also require rock/rubble fill to prevent access into the outlet. The outlet may already be partially collapsed. If additional rock/rubble is required to adequately prevent access into the tunnel, the maximum volume of rock/rubble required to fill the outlet is approximately 2 cubic yards. The outer part of this rock should also be sized similarly to that described above to prevent removal by hand.

All rock fill will be obtained from the immediate vicinity as directed by the Forest Service. Every attempt will be made to minimize haul distances while obtaining rock suitable for the required application. In the event that sufficiently sized rock is not available in the immediate vicinity, contingency plans that require either excavation or hauling as directed by the Forest Service will be implemented. Any excavation and/or hauling will require rehabilitation of the disturbed areas back to natural conditions as directed by the Forest Service.

White Miller Lake

White Miller Lake is located in the Swift Creek Drainage just below Farmers Lake. The outlet to the lake is a small wooden structure at the south end of the lake. The wooden structure currently does little to control the flows at White Miller Lake and can be removed with minimal effects on the water routing through the lake. This will allow the dam to be classified as a No-Hazard dam. No other work is required. The dismantled wood can be removed from the site, buried on site, burned, or scattered in vicinity as determined by the Forest Service.

In addition to removal of the existing wooden structure, there may be some shaping and earthwork required to restore natural flows and site contours. All of this work will be performed in a similar fashion and with methods used at Farmers and Water Lily Lakes.

Appendix A - Memorandum of Understanding between State of Utah and U.S. Forest Service

RECEIVED

JAN 20 1981

MEMORANDUM OF UNDERSTANDING

**DIVISION OF WATER RIGHTS
VERNAL, UTAH**

Intermountain Region
Forest Service
U. S. Department of Agriculture

Division of Water Rights
Department of Natural Resources
State of Utah

THIS MEMORANDUM OF UNDERSTANDING is entered into by the Division of Water Rights, Department of Natural Resources, State of Utah, hereafter called the Division, and the Intermountain Region, Forest Service, Department of Agriculture, hereafter referred to as the Forest Service.

WHEREAS, the Forest Service and the Division have certain responsibilities for the safety of dams by virtue of land status or public safety, and

WHEREAS, the Division has been created under Utah Statutes 73-5-5, 6, 7, 12, and 13, to provide public safety and resource protection by supervision and administration of a system to safeguard dams in the State of Utah, and

WHEREAS, the Forest Service under Acts of June 4, 1897 (16 U.S.C. 551), February 1, 1905 (16 U.S.C. 473), July 22, 1937 (16 U.S.C. 1010), June 12, 1960 (16 U.S.C. 528), as amended, is directed to regulate the occupancy and use of the National Forests and National Grasslands, and

WHEREAS, the Forest Service under administrative Manual requirements is directed to supervise and administer a system of inspections to safeguard dams located on National Forest lands, and

WHEREAS, the Forest Service and the Division mutually desire:

1. To periodically inspect dams located on National Forest lands.
2. To develop and document procedural methods to minimize duplication of effort and facilitate complementary inspections of dams.

NOW THEREFORE, the parties agree as follows:

1. The Forest Service agrees:
 - a. To coordinate with the Division at the local and state levels in developing an annual inspection schedule for dams.
 - b. To provide the Division copies of dam inspection reports made by Forest Service engineers.

c. To notify the Division of suspected safety hazards of dams located on National Forest lands.

2. The Division agrees:

a. To provide notification to the appropriate Forest Supervisor of the dams scheduled for Division inspection each calendar year.

b. To provide the Forest Service copies of dam inspection reports made by Division engineers.

c. To notify the Forest Service of suspected safety hazards of dams located on, or affecting, National Forest lands.

3. It is mutually agreed:

a. To cooperate in the periodic inspection of dams located on National Forest lands in the State of Utah.

b. To develop and seek application of safety measures required to protect public safety and resources.

c. That nothing herein shall be construed in any way as limiting the authority of the Division in carrying out its legal responsibilities for management or regulation of dam safety.

d. That nothing herein shall be construed as limiting or affecting in any way the legal authority of the Forest Service in connection with the proper administration and protection of National Forest System lands, in accordance with Federal laws and regulations.

e. That nothing in the Memorandum of Understanding shall be construed as obligating the Forest Service or the Division to expend funds in any contract or other obligation for future payment of funds or services in excess of those available or authorized for expenditure.

f. That amendments to this Memorandum of Understanding may be proposed by either party and shall become effective after written approval by both parties.

g. That this Memorandum of Understanding shall continue in force unless terminated by either party upon thirty (30) days notice in writing to the other of intention to terminate upon a date indicated.

h. Forest Service and local Division inspection personnel¹ will coordinate their annual inspection schedules to avoid duplication of effort.

¹ See Exhibit 1 attached hereto.

i. That agreements between Forest Supervisors and local dam inspection personnel of the Division can be made as amendments to this document if such agreements are deemed necessary.

j. That no member of or delegate to Congress, or Resident Commissioner of the United States shall be admitted to any share or part of this agreement, or to any benefit that may arise therefrom.

k. That each and every provision of this Memorandum is subject to the laws of the State of Utah, the laws of the United States, the regulations of the Secretary of Agriculture, and the regulations of the Division.

IN WITNESS THEREOF, the parties hereto have caused this Memorandum of Understanding to be executed as of the last date signed below.



JEFF M. SIRMON
Acting Regional Forester
Intermountain Region
USDA Forest Service

Date

4/4/80



DEE C. HANSEN
State Engineer
Division of Water Rights
Department of Natural Resources
State of Utah

Date

April 14, 1980

This Memorandum of Understanding is applicable to the following National Forests:

Ashley National Forest
437 East Main
Vernal, Utah 84078

Dixie National Forest
Federal Building
82 North 100 East
P.O. Box 580
Cedar City, Utah 84720

Fishlake National Forest
P.O. Box 628
170 North Main Street
Richfield, Utah 84701

Manti-LaSal National Forest
350 East Main Street
Price, Utah 84501

Uinta National Forest
P.O. Box 1428
88 West 100 North
Provo, Utah 84601

Wasatch National Forest
8226 Federal Building
125 South State Street
Salt Lake City, Utah 84138

Appendix B - Drawings

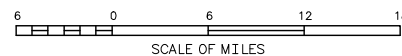
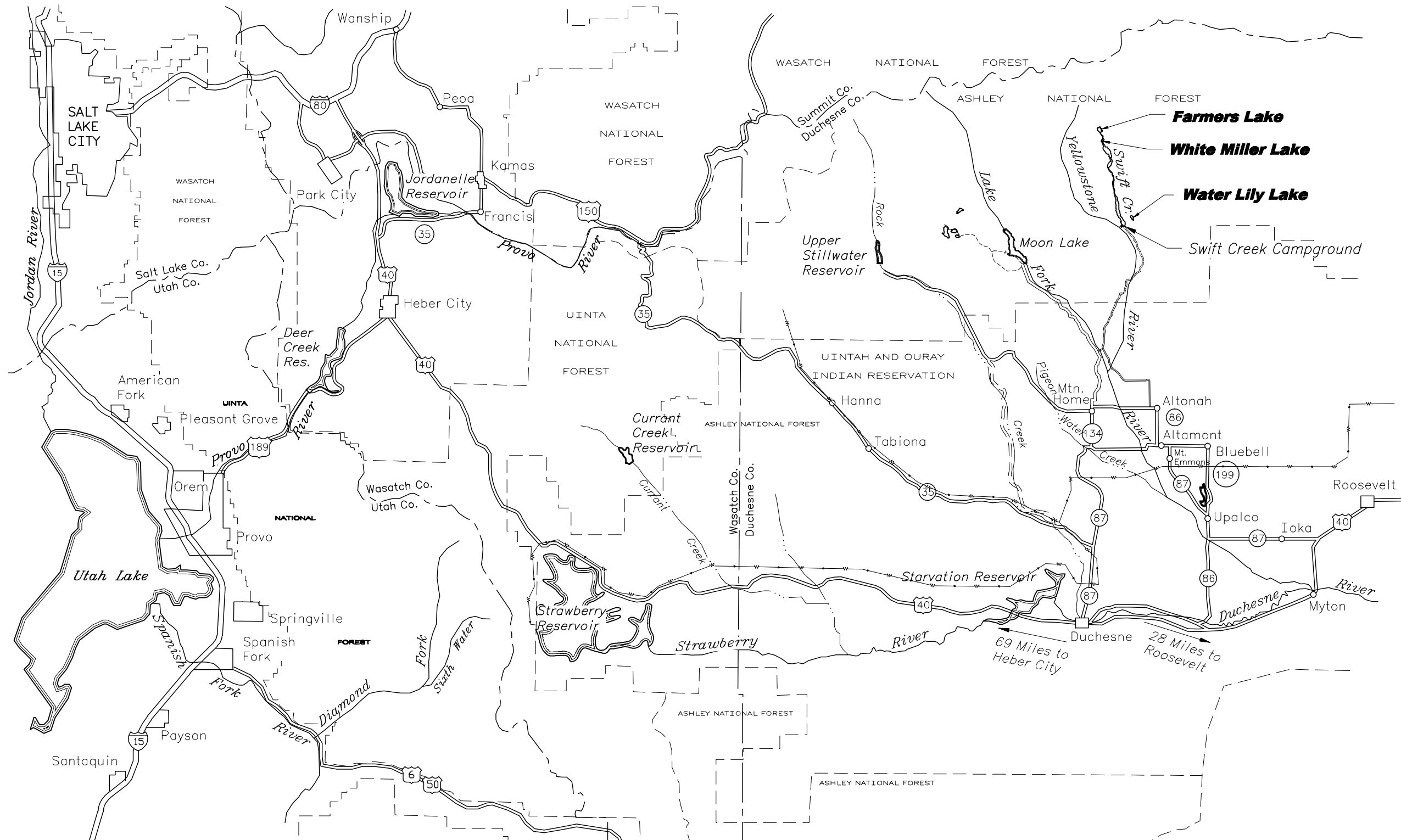

PLOTTED BY: DLOFT
 L:\PROJECTS\Water Lily Farmer White.DWG
 L:\PROJECTS\Water Lily Farmer White.DWG

ALWAYS THINK SAFETY	
<small>UNITED STATES DEPARTMENT OF THE INTERIOR BUREAU OF RECLAMATION</small>	
<small>PROVO AREA OFFICE PROVO, UTAH</small>	
SWIFT CREEK DRAINAGE LAKES LOCATION MAP	
DESIGNED _____	CHECKED _____
DRAWN _____	TECH. APPR. _____
APPROVED _____	
<small>PROVO, UTAH</small>	<small>PEER REVIEWER</small>
<small>2896-85-23</small>	DWG NO.

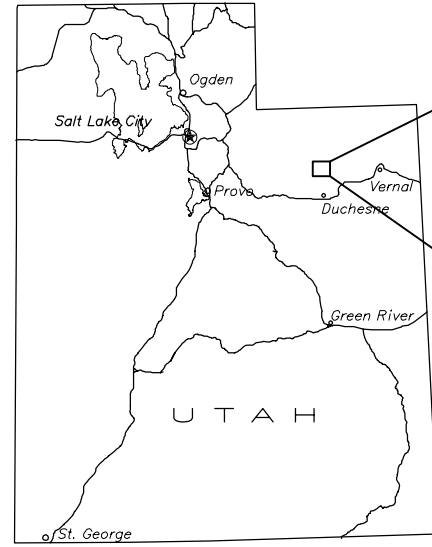

KEY MAP

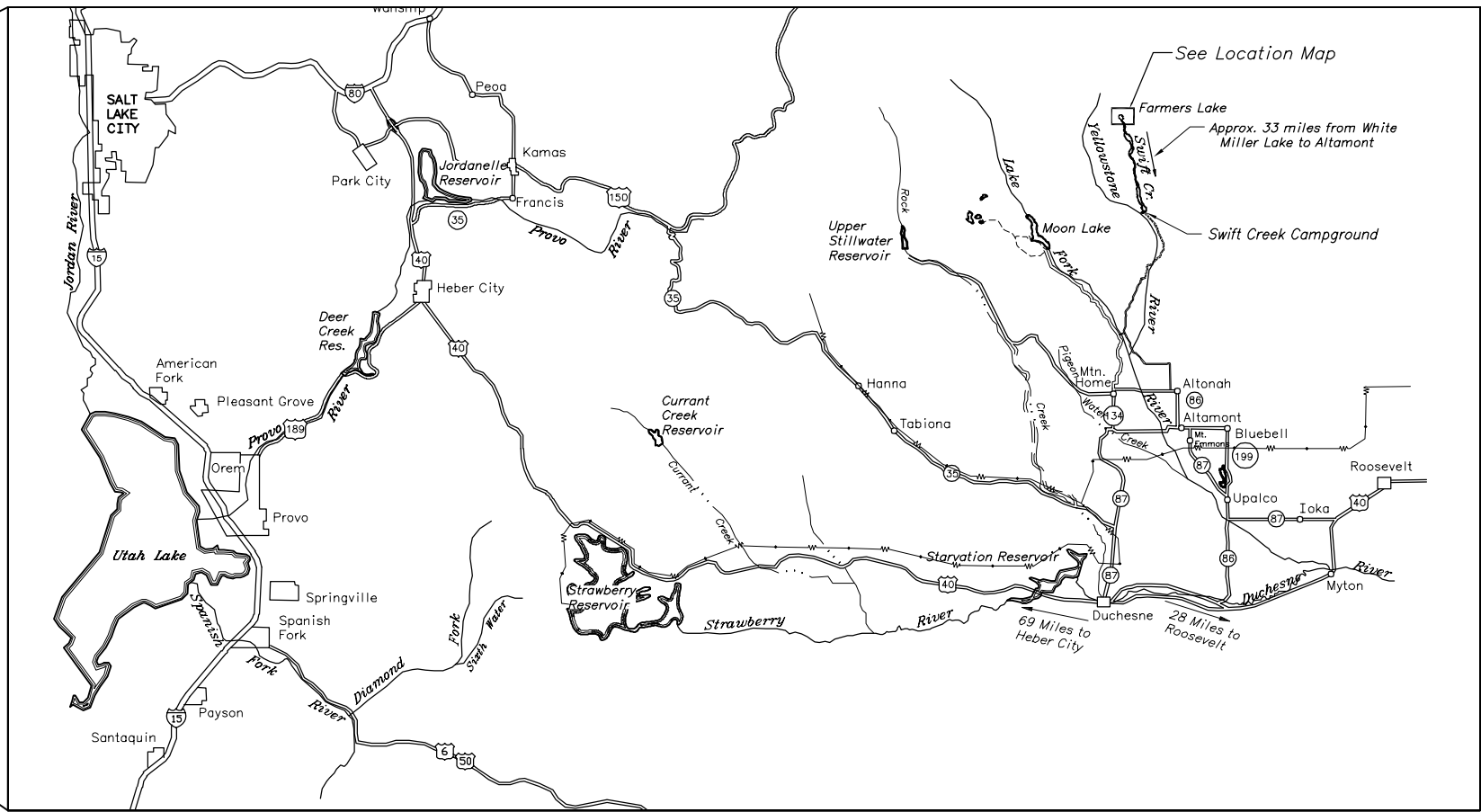

VICINITY MAP

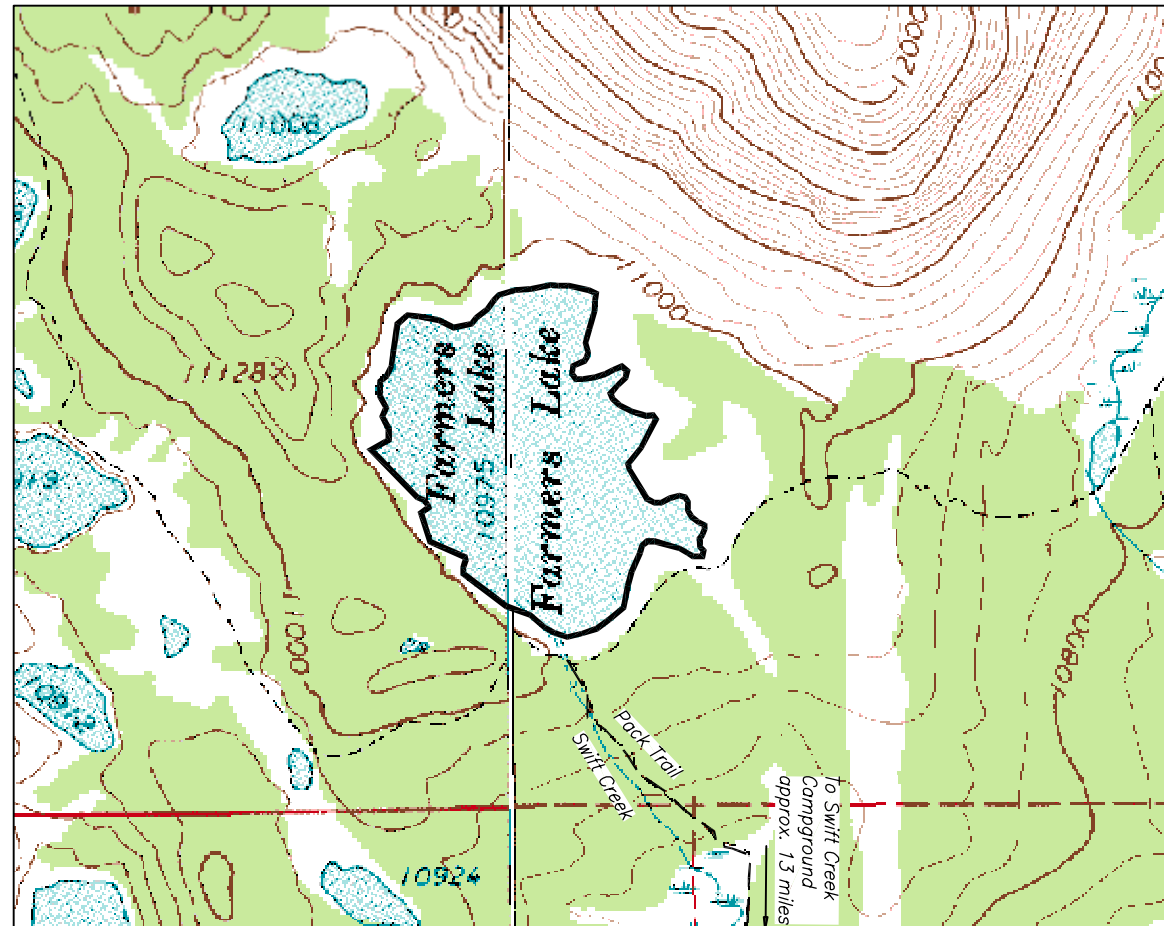
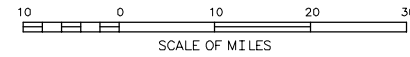

LOCATION MAP
NOT TO SCALE



ALWAYS THINK SAFETY

UNITED STATES
DEPARTMENT OF THE INTERIOR
BUREAU OF RECLAMATION
PROVO AREA OFFICE
PROVO, UTAH

FARMERS LAKE DAM STABILIZATION
VICINITY AND LOCATION MAP

DESIGNED /S/ DIANNE LOFT CHECKED /S/ CARY SOUTHWORTH

DRAWN /S/ DIANNE LOFT TECH. APPR. /S/ RICK SCOTT, P.E.

APPROVED /S/ CLYDE THOMAS, P.E.
PEER REVIEWER

PROVO, UTAH

2886-83-20

OA58-418-62

PLOTTED BY

CAD FILENAME
Z:\Archive\OASB_LISDA\OASB-418-62 THRU 64.dwg

D

C

B

A

D

C

B

A

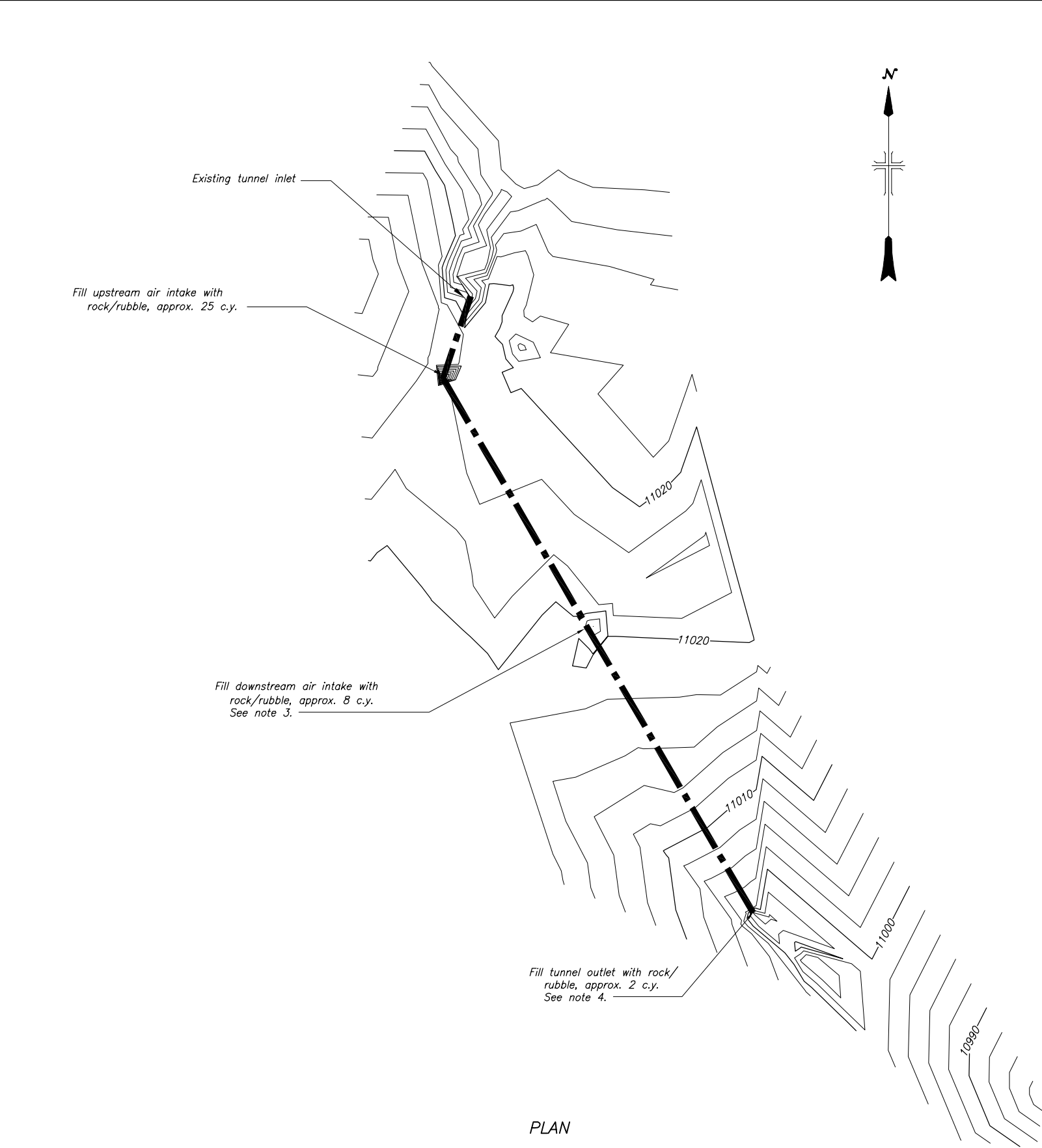

PLAN

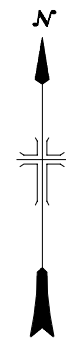
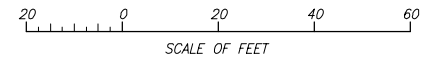

Fill upstream air intake with rock/rubble, approx. 25 c.y.

Fill downstream air intake with rock/rubble, approx. 8 c.y. See note 3.

Fill tunnel outlet with rock/rubble, approx. 2 c.y. See note 4.

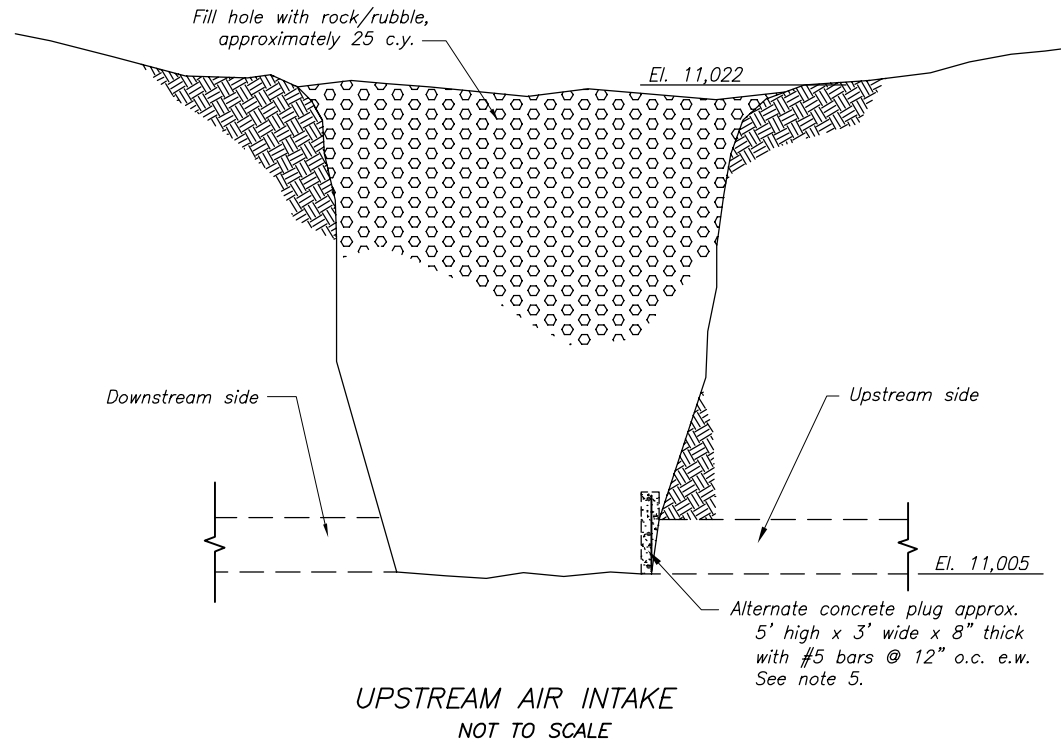

UPSTREAM AIR INTAKE NOT TO SCALE

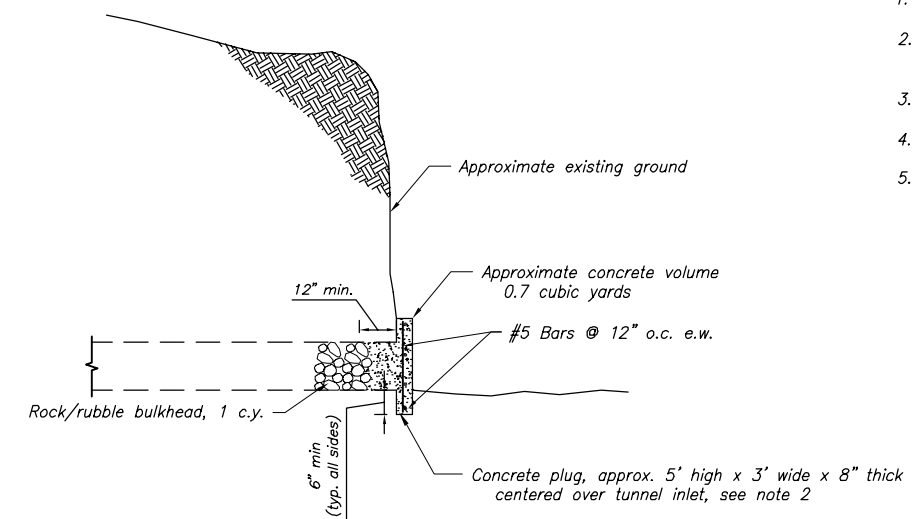

TUNNEL INLET PLUG NOT TO SCALE

NOTES

1. Original outlet tunnel gate located at the tunnel inlet no longer exists.
2. Excavate/remove existing rock as necessary to competent tunnel location that allows placement of concrete plug.
3. Fill downstream air intake hole with rock/rubble at least three-fourths to the top of existing ground.
4. Place rock/rubble fill at tunnel outlet of sufficient size and quantity to prevent access or removal.
5. As determined in the field, if competent rock at the tunnel inlet that is suitable for a concrete plug cannot be obtained, the concrete plug shall be repositioned at the upstream air intake. Place rock/rubble at tunnel inlet in lieu of concrete plug.

CAD SYSTEM: MICROCAD 9.05
 DATE AND TIME PLOTTED: 27-Apr-06 2:45 PM
 C:\Archives\OA58_USDA\OA58-418-66 AND 67.dwg
 SWINTERTON

ALWAYS THINK SAFETY	
<small>UNITED STATES DEPARTMENT OF THE INTERIOR BUREAU OF RECLAMATION PROVO AREA OFFICE PROVO, UTAH</small>	
FARMERS LAKE DAM STABILIZATION TUNNEL MODIFICATION PLAN AND DETAILS	
DESIGNED <u>/S/ SCOTT WINTERTON</u>	CHECKED <u>/S/ CARY SOUTHWORTH</u>
DRAWN <u>/S/ SCOTT WINTERTON</u>	TECH. APPR. <u>/S/ RICK SCOTT, P.E.</u>
APPROVED <u>/S/ CLYDE THOMAS, P.E.</u>	
<small>PROVO, UTAH 2006-03-28</small>	
OA58-418-66	

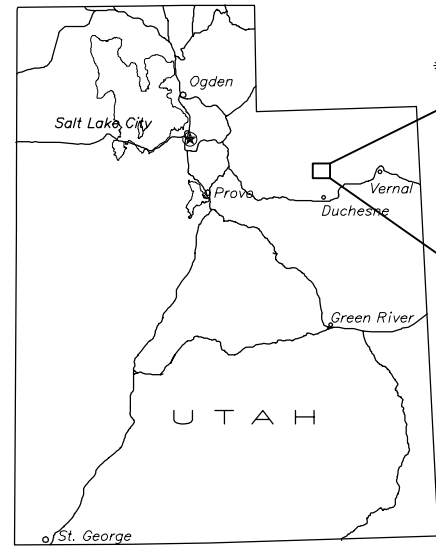

KEY MAP

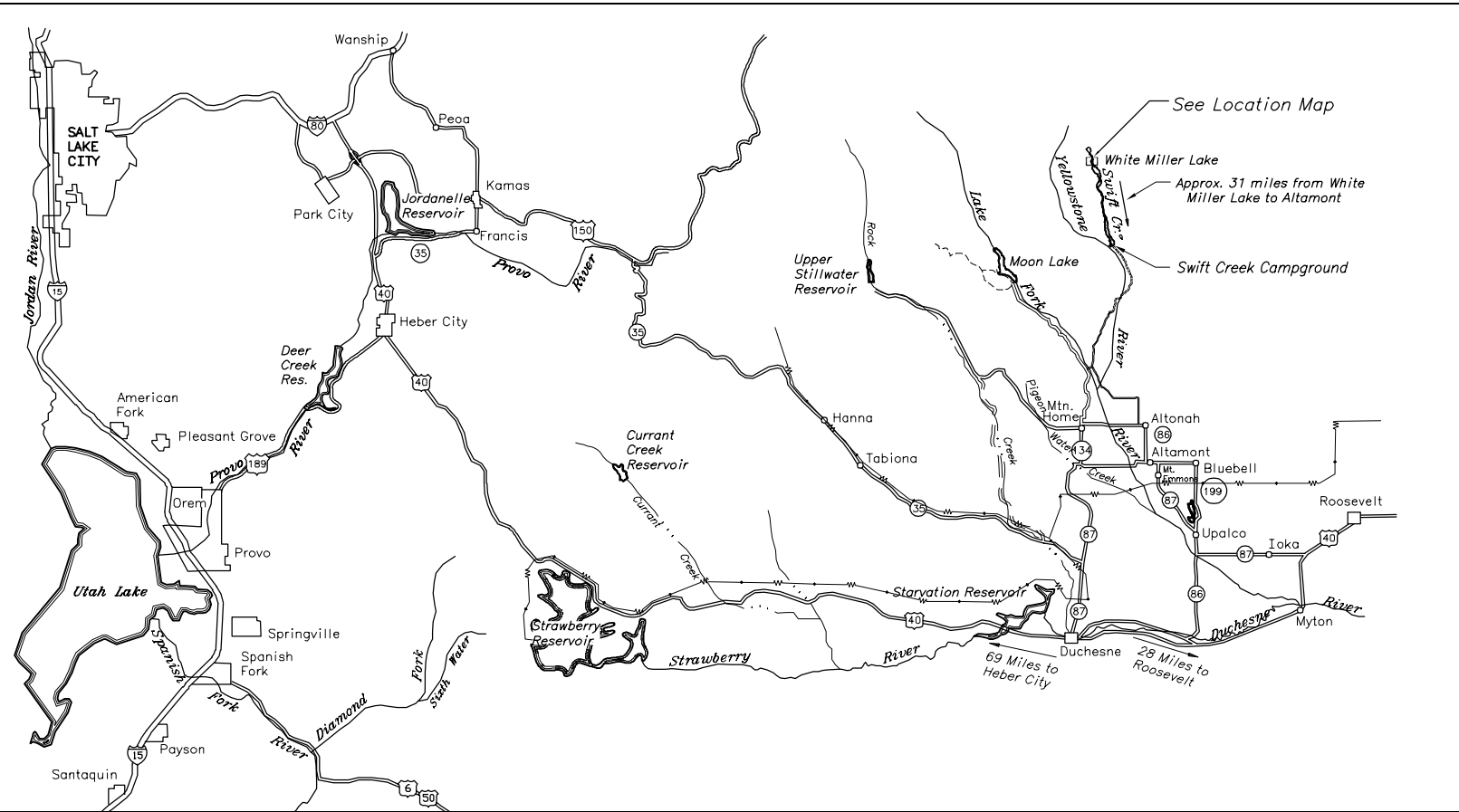

VICINITY MAP

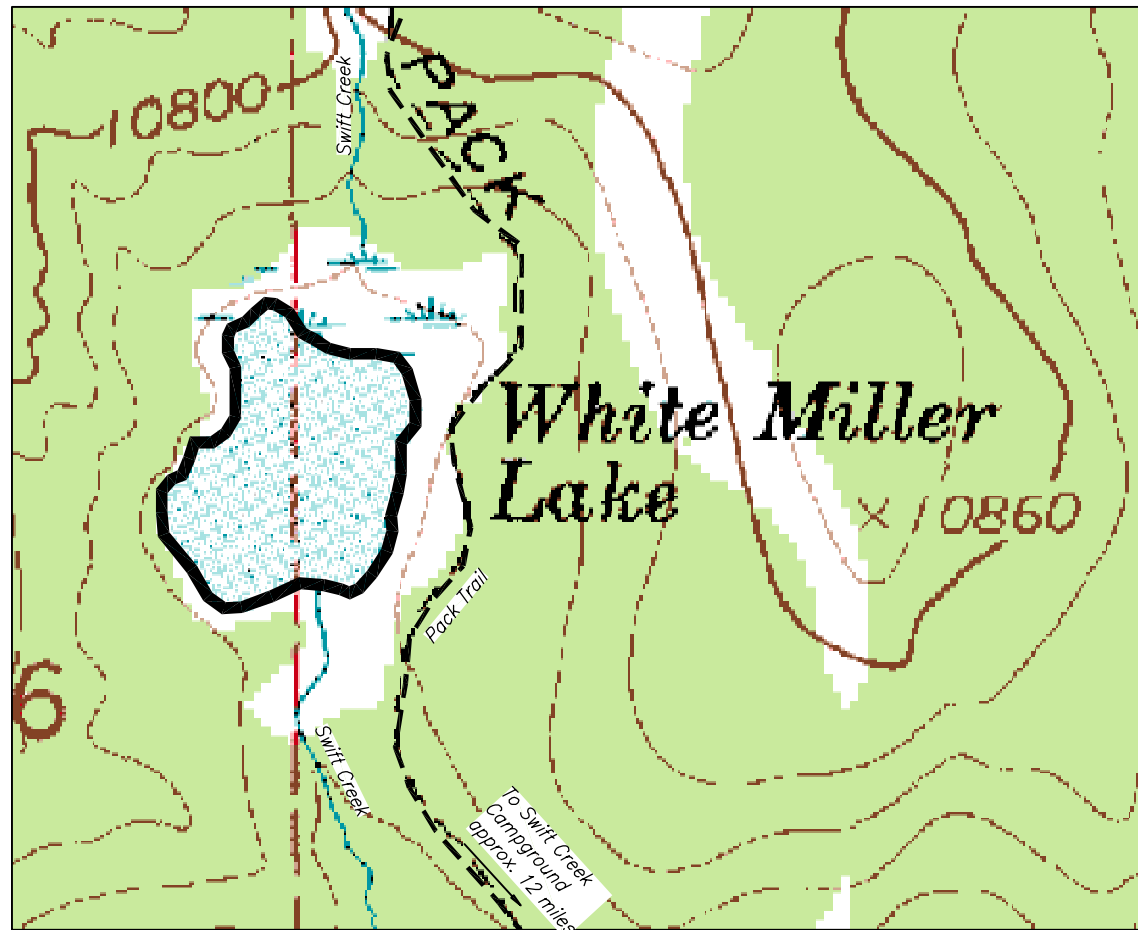
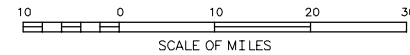

LOCATION MAP
NOT TO SCALE



ALWAYS THINK SAFETY

UNITED STATES
DEPARTMENT OF THE INTERIOR
BUREAU OF RECLAMATION
PROVO AREA OFFICE
PROVO, UTAH

WHITE MILLER LAKE DAM STABILIZATION
VICINITY AND LOCATION MAP

DESIGNED /S/ DIANNE LOFT CHECKED /S/ CARY SOUTHWORTH

DRAWN /S/ DIANNE LOFT TECH. APPR. /S/ RICK SCOTT, P.E.

APPROVED /S/ CLYDE THOMAS, P.E.
PEER REVIEWER

PROVO, UTAH

2886-93-20

OA58-418-63

PLOTTED BY

CAD FILENAME
Z:\Archive\OASB_LISDA\OASB-418-63 THRU 64.dwg

Approximate lake boundary at high water

Remove wood outlet structure, see note 1

Outlet channel

10686

10684

10682

NOTE

1. Dispose of wood outlet structure by burning, burying on site, scattering on site, or removal as directed by the Forest Service.

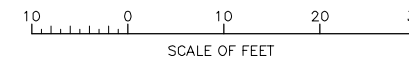

DATE AND TIME PLOTTED
28-Apr-06 7:22 AM
C:\Archives\OA58_USDA\OA58-418-66 AND 67.dwg
SWINTERTON

CAD SYSTEM
PROVIDED
C:\Archives\OA58_USDA\OA58-418-66 AND 67.dwg



ALWAYS THINK SAFETY

UNITED STATES
DEPARTMENT OF THE INTERIOR
BUREAU OF RECLAMATION
PROVO AREA OFFICE
PROVO, UTAH

WHITE MILLER DAM STABILIZATION
OUTLET MODIFICATION

SITE PLAN

DESIGNED /S/ SCOTT WINTERTON CHECKED /S/ CARY SOUTHWORTH

DRAWN /S/ SCOTT WINTERTON TECH. APPR. /S/ RICK SCOTT, P.E.

APPROVED /S/ CLYDE THOMAS, P.E.
PEER REVIEWER

PROVO, UTAH

2006-01-19

OA58-418-67

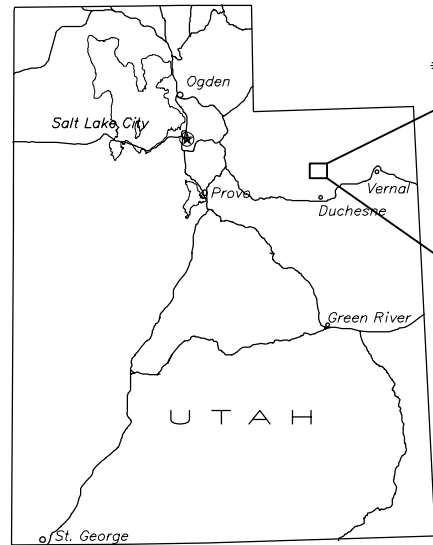

KEY MAP

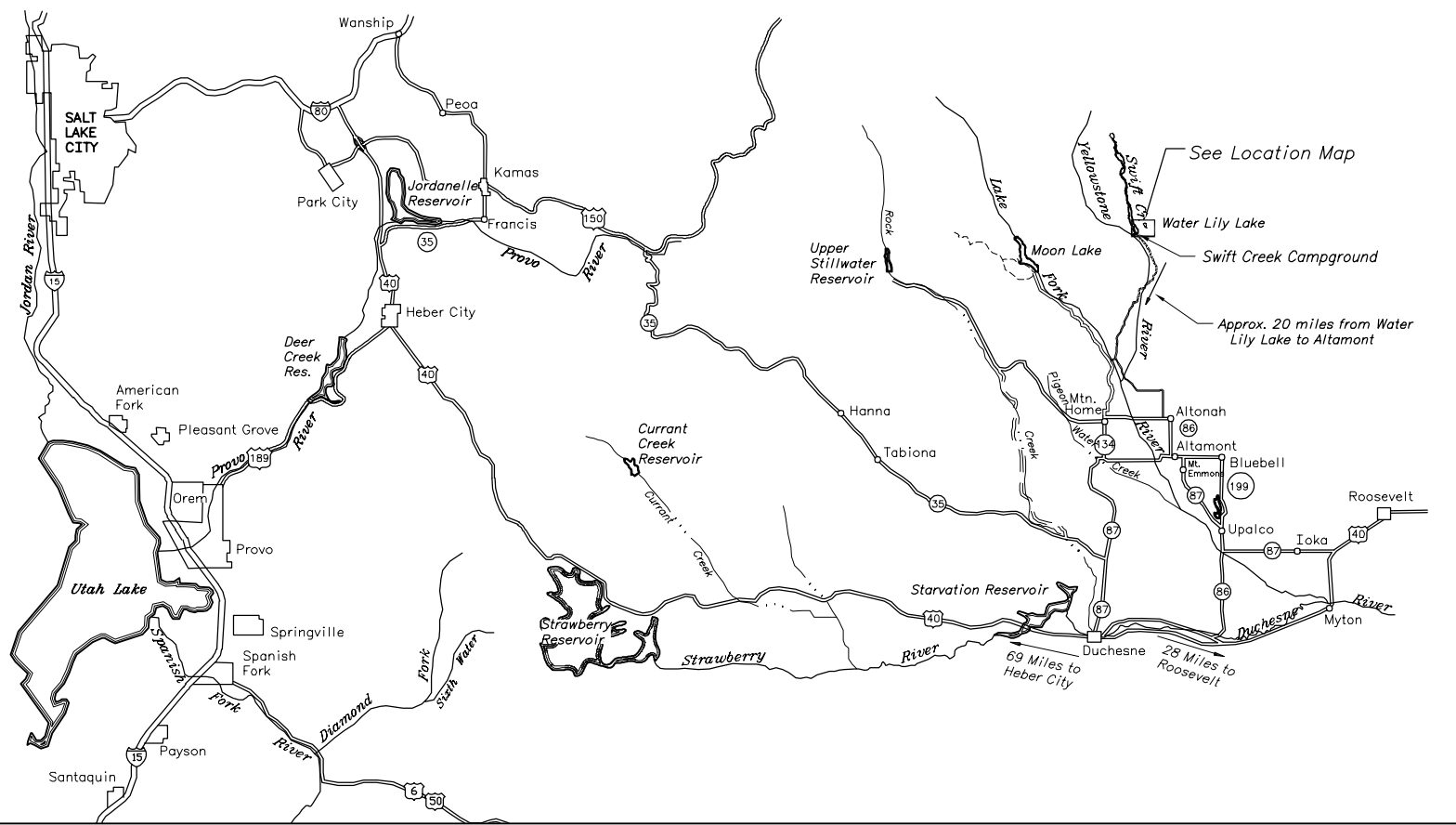

VICINITY MAP

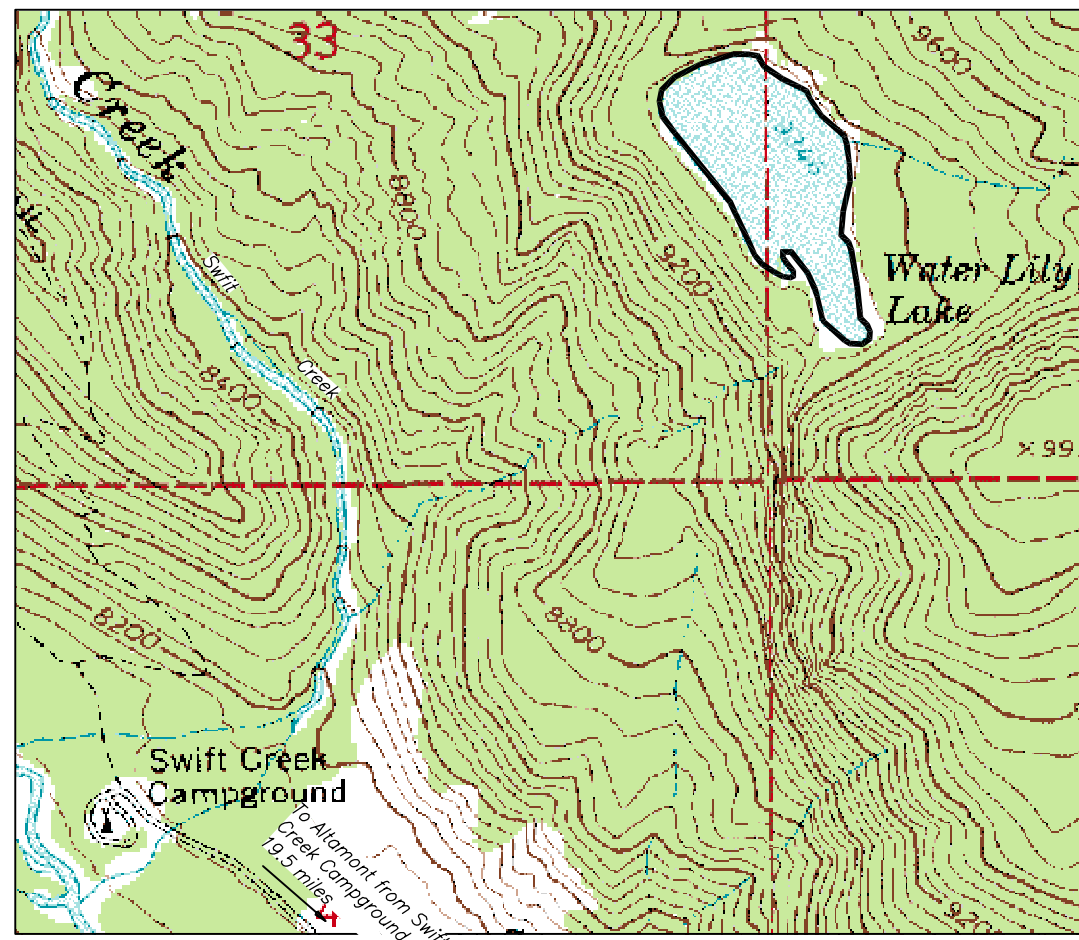
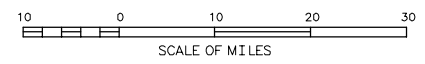

LOCATION MAP
NOT TO SCALE



ALWAYS THINK SAFETY

UNITED STATES
DEPARTMENT OF THE INTERIOR
BUREAU OF RECLAMATION
PROVO AREA OFFICE
PROVO, UTAH

WATER LILY LAKE DAM STABILIZATION
VICINITY AND LOCATION MAP

DESIGNED /S/ DIANNE LOFT CHECKED /S/ CARY SOUTHWORTH
DRAWN /S/ DIANNE LOFT TECH. APPR. /S/ RICK SCOTT, P.E.
APPROVED /S/ CLYDE THOMAS, P.E.
PEER REVIEWER

PROVO, UTAH 2896-83-89

CAD FILENAME: Z:\Archive\OASB_LISDA\OASB-418-62 Thru\64.dwg
 PLOTTED BY:

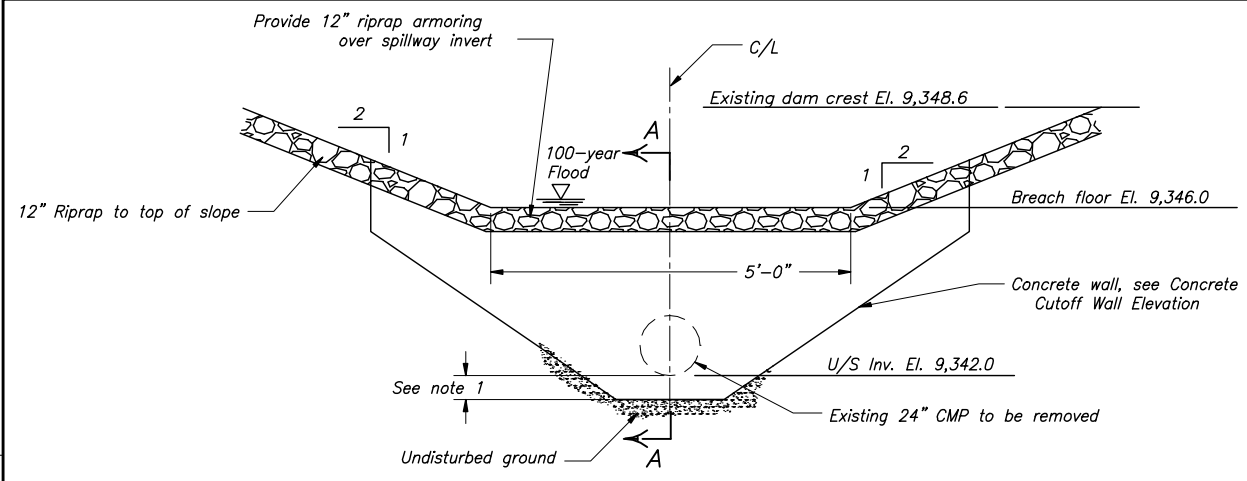

SPILLWAY CHANNEL ELEVATION AT STA. 0+00

Not to scale

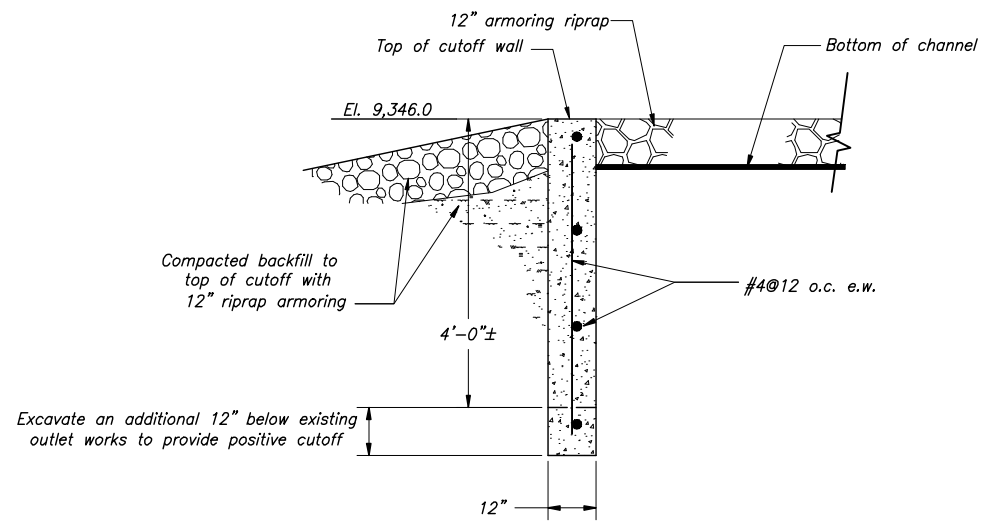

SECTION A-A

Not to scale

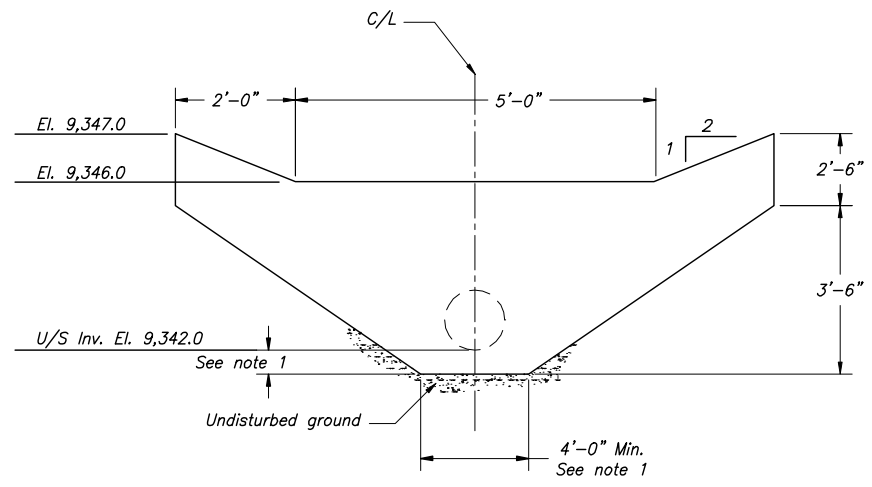

CONCRETE CUTOFF WALL ELEVATION AT STATION 0+00

Not to scale

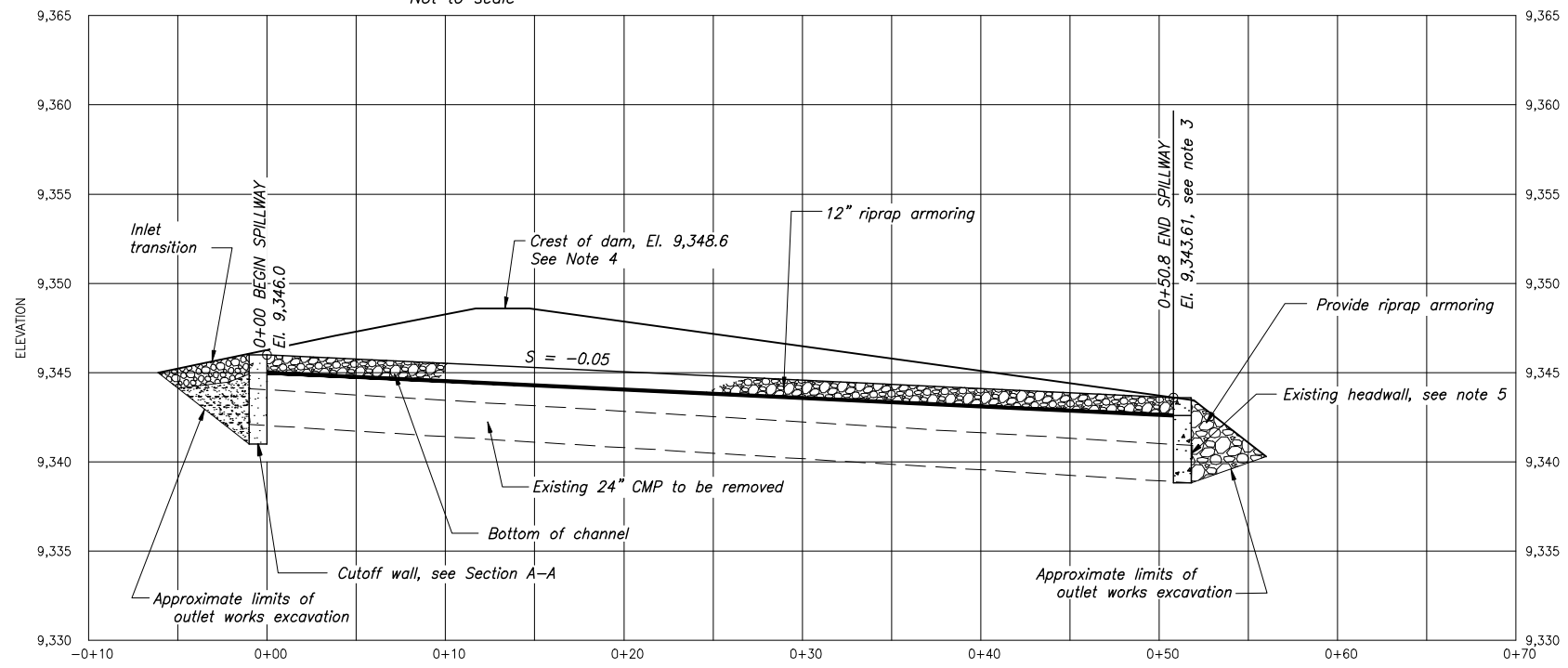

PROFILE

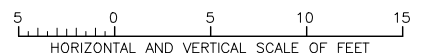

NOTES

1. Excavate a minimum of 12 inches beyond edge of existing outlet works on bottom and sides for concrete placement.
2. The original (natural) lake elevation is at approximately 9346 feet.
3. Daylight spillway invert to match existing ground. Provide riprap armor from end of spillway to existing ground to prevent headcutting and erosion.
4. Dam crest elevation obtained from Utah State data sheets.
5. Existing headwall for grade control may or may not be left in place as a downstream grade control. If removed, a downstream grade control identical to the upstream grade control will be required.

ALWAYS THINK SAFETY

UNITED STATES
DEPARTMENT OF THE INTERIOR
BUREAU OF RECLAMATION
PROVO AREA OFFICE
PROVO, UTAH

WATER LILY LAKE DAM STABILIZATION
SPILLWAY MODIFICATION

PROFILE, SPILLWAY CHANNEL ELEVATION,
CONCRETE CUTOFF ELEVATION, AND SECTION A-A

DESIGNED _____ CHECKED _____
DRAWN _____ TECH. APPR. _____
APPROVED _____ PEER REVIEWER _____
PROVO, UTAH 2006-3-28 DWG NO

I:\High Mountain Lakes\Water Lily Typing.dwg

Appendix C - Inflow Hydrology Output Files

AWLb

5.	1 JAN 0535	68	0.	*	1 JAN 1150	143	2.	*	1 JAN 1805	218	9.	*	2 JAN 0020	293
5.	1 JAN 0540	69	0.	*	1 JAN 1155	144	3.	*	1 JAN 1810	219	9.	*	2 JAN 0025	294
5.	1 JAN 0545	70	0.	*	1 JAN 1200	145	6.	*	1 JAN 1815	220	9.	*	2 JAN 0030	295
5.	1 JAN 0550	71	0.	*	1 JAN 1205	146	9.	*	1 JAN 1820	221	9.	*	2 JAN 0035	296
5.	1 JAN 0555	72	0.	*	1 JAN 1210	147	13.	*	1 JAN 1825	222	9.	*	2 JAN 0040	297
4.	1 JAN 0600	73	0.	*	1 JAN 1215	148	17.	*	1 JAN 1830	223	9.	*	2 JAN 0045	298
4.	1 JAN 0605	74	0.	*	1 JAN 1220	149	20.	*	1 JAN 1835	224	9.	*	2 JAN 0050	299
4.	1 JAN 0610	75	0.	*	1 JAN 1225	150	21.	*	1 JAN 1840	225	8.	*	2 JAN 0055	300
				*				*				*		

PEAK FLOW (CFS)	TIME (HR)	6-HR MAXIMUM AVERAGE FLOW	24-HR MAXIMUM AVERAGE FLOW	72-HR MAXIMUM AVERAGE FLOW	24.92-HR MAXIMUM AVERAGE FLOW
21.	12.50	12.	5.	5.	5.
0.237		0.396	0.396	0.396	0.396
6.		10.	10.	10.	10.

CUMULATIVE AREA = 0.48 SQ MI

RUNOFF SUMMARY
 FLOW IN CUBIC FEET PER SECOND
 TIME IN HOURS, AREA IN SQUARE MILES

TIME OF STAGE	OPERATION	STATION	PEAK FLOW	TIME OF PEAK	AVERAGE FLOW FOR MAXIMUM PERIOD	BASIN AREA	MAXIMUM STAGE	MAX
					6-HOUR	24-HOUR	72-HOUR	
+	HYDROGRAPH AT	WL_B	41.	12.67	13.	5.	4.	0.35
+	ROUTED TO	WL1y	9.	14.67	8.	3.	3.	0.35
+	14.50							9346.31
	ROUTED TO							

		4R	9.	14.67	AWLb	8.	3.	3.	0.35
+	HYDROGRAPH AT	Basin	19.	12.42	5.	2.	2.	0.13	
+	2 COMBINED AT	2C	21.	12.50	12.	5.	5.	0.48	
+	ROUTED TO	2R	21.	12.50	12.	5.	5.	0.48	

*** NORMAL END OF HEC-1 ***

Appendix D – Construction Quantities

**Uintah Mountains
High Mountain Lakes
Swift Creek Drainage**

Farmers Lake Tunnel	Rubble (cy)	Concrete (cy)
Inlet Plug	1	0.7
Upstream Air Intake	25	0
Downstream Air Intake	8	0
Outlet Fill	2	0

Water Lily Lake Outlet Removal (6.35% slope)	Spillway Width*	Spillway Elevation	Spillway Excavation (cy)	Riprap (cy)	
				Spillway (cy)	Outlet (cy)
	5'	9346	160	40	2
					1

* 2:1 sideslopes, both sides, finished width, 15-foot wide inlet transition

Appendix E – Dam Break Output Files

CROSS SECTION NO. 7
 REACH LENGTH (D) .49 MI
 FLOOD DEPTH (FLD) 10.00 FT

ELEV.(FT) (HS)	8377.3	8377.5	8377.7	8377.9	8378.2	8378.3	8378.6	8378.8
TWIDTHS(FT) (BS)	.0	1.2	2.4	3.6	4.8	5.9	7.1	8.3
INACTIVE TW(FT) (BSS)	.0	.0	.0	.0	.0	.0	.0	.0
MANNING N (CM)	.045	.045	.045	.045	.045	.045	.045	.045

AN ASTERISK (*) BESIDE A PARAMETER IMPLIES THAT A DEFAULT VALUE WAS COMPUTED

NAME OF DAM: water Lily NAME OF RIVER:

RVR MILE FROM DAM	MAX FLOW (CFS)	MAX ELEV (FT-MSL)	MAX DEPTH (FT)	TIME(HR) MAX DEPTH	TIME(HR) FLOOD	TIME(HR) DEFLOOD	FLOOD DEPTH(FT)
.00	13.	9251.62	.64	3.33	.00	.00	10.00
.08	13.	9068.88	.42	3.36	.00	.00	10.00
.21	13.	8800.88	.50	3.38	.00	.00	10.00
.30	12.	8648.62	.88	3.41	.00	.00	10.00
.36	12.	8566.17	.92	3.45	.00	.00	10.00
.44	12.	8434.38	.67	3.48	.00	.00	10.00
.49	12.	8378.06	.74	3.51	.00	.00	10.00

ANALYSIS IS COMPLETE