



U.S. Department  
of Transportation  
**Federal Highway**

**Administration**

400 Seventh St., S.W.  
Washington, D.C.  
20590

Refer to: HSA-1\WZ-73

Mr. DAVID Gertz  
Traffix Devices, Inc.  
Director of Engineering  
220 Calle Pintoresco  
San Clemente, CA 92672

Dear Mr. Gertz:

Thank you for your letters of January 18, February 9, and May 9 requesting Federal Highway Administration (FHWA) acceptance of a number of your company's work zone traffic control devices including vertical panels and Traffix portable sign stands as crashworthy traffic control devices for use in work zones on the National Highway System (NHS). Accompanying your letters were crash test reports by Karco Engineering and videos of the tests. You requested that we find the devices detailed below acceptable for use on the NHS under the provisions of National Cooperative Highway Research Program (NCHRP) Report 350 "Recommended Procedures for the Safety Performance Evaluation of Highway Features."

#### **Introduction**

The FHWA guidance on crash testing of work zone traffic control devices is contained in two memoranda. The first, dated July 25, 1997, titled "INFORMATION: Identifying Acceptable Highway Safety Features," established four categories of work zone devices: Category I devices were those lightweight devices which could be self-certified by the vendor, Category II devices were other lightweight devices which needed individual crash testing, Category III devices were barriers and other fixed or massive devices also needing crash testing, and Category IV devices were trailer mounted lighted signs, arrow panels, etc. The second guidance memorandum was issued on August 28, 1998, and is titled "INFORMATION: Crash Tested Work Zone Traffic Control Devices." This later memorandum lists devices that are acceptable under Categories I, II, and III.

A brief description of the tested devices follows. All test articles are shown in Enclosure 1 for reference. Reflectorized panels were 10 mm thick corrugated plastic by either Coreplast (diamond signs) or Inteplast (barricade rails.)

#### **Test 1. Vertical Panel with 914 x 914 mm (36 x 36 inch) Coreplast Rigid Plastic Sign**

The base is recycled crumb rubber and the panel is corrugated plastic. The frame is blow-molded HDPE plastic. The frame is plugged into the socket in the rubber base and relies on indented areas in the rubber socket to hold it in place.

Component	Material	Height	Width	Thickness	Weight
Base	Rubber	3 inches	17 x 27.25 in	3 inches	42 pounds
Frame	Plastic	44 inches	10.5 inches	2.0 inches	4 pounds
Sign	Plastic	58 inches	36x36	0.4 inches	4.5 pounds
Light	n/a	n/a	n/a	n/a	n/a

[For this and the following tables, 1 inch = 25.4 mm, 1 pound = 0.45 kg]

**Test 2. Vertical Panel (203 mm, 8 inches wide) with 19 kg (42 pound) base, Empco-Lite Model Number 100 Warning Light and Light Bolt Heavy Duty Protector**

Similar to the above device, minus the diamond warning sign, but with a light added to the top.

Component	Material	Height	Width	Thickness	Weight
Base	Rubber	3 inches	17 x 27.25 in	3 inches	42 pounds
Frame/Panel	Plastic	44 inches	10.5 inches	2.0 inches	4 pounds
Light	Empco-Lite	54 inches	n/a	n/a	4.5 pounds

**Test 3. Traffix Stand with 1220 x 1220 mm (48 x 48 inch) Coreplast Rigid Plastic Sign mounted 305 mm (12 inches) above the ground**

An “X-footprint” compact portable sign stand with the metal mast extending no higher than the bottom of the diamond warning sign.

Component	Material	Height	Width	Thickness	Weight
Base	Hot Rolled Steel	9 inches	1.75 inches square	12 ga	19 pounds
Sign	Plastic	72 inches	48x48	0.4 in	8 pounds
Ribs	Fiberglass V	50 inches	1 1/4 in	1/4 in	2.0 pounds
Light (none)	n/a	n/a	n/a	n/a	n/a

**Test 4. Aluminum Buster Sign Stand with 1220 x 1220 mm (48 x 48 inch) Roll Up Sign mounted 305 mm (12 inches) above the ground**

An “X-footprint” portable sign stand with a telescoping mast supporting the diamond warning sign, topped by a flag bracket. This stand was tested with the mast completely lowered.

Component	Material	Height to top	Width	Thickness	Weight
Base	Steel	18 inches	2.5 in tube	0.250 wall	38 pounds
Outer Mast	Aluminum	53 inches	1.5 in	0.100 wall	3 pounds
Inner Mast	PVC	91 inches	1.25 inches	0.250 wall	5 pounds
Sign	48x48 rollup	80 inches	48x48	0.035 in	4 pounds
Light (none)	[flag bracket]	n/a	n/a	n/a	n/a

**Test 5. Big Buster Dual Spring Folding Leg Sign Stand with 1220 x 1220 mm (48 x 48 inch)**

**Coreplast Rigid Plastic Sign mounted 1525 mm (60 inches) Above the Ground**

An “X-footprint” portable sign stand with a telescoping mast supporting the diamond warning sign. This stand was tested with the mast extended with no lights or flags.

Component	Material	Height to top	Width	Thickness	Weight
Base	Steel	18 inches	2.5 in tube	0.250 wall	38 pounds
Outer Mast	Aluminum	69 inches	1.5 in Al	0.100 wall	3 pounds
Inner Mast	PVC	125 inches	1.25 in PVC	0.250 wall	5 pounds
Sign	Plastic	125 inches	48x48	0.4in	8 pounds
Light (none)	[flag bracket]	n/a	n/a	n/a	n/a

**Test 6. Zephyr Portable Sign Stand with 914 x 914 mm (36x36 inch) Coreplast Rigid Plastic Sign mounted 330 mm (13 inches) above the ground**

A compact sign stand mounted on a rubber overmolded steel plate. The metal mast extending no higher than the bottom of the diamond warning sign.

Component	Material	Height to top	Width	Thickness	Weight
Base	Rubber	3 inches	17 x 27.25 in	3 in.	42 pounds
Mast	Steel	14 in	2 x 2 in	12 ga	2 pounds
Sign	Plastic	66 inches	36x36	0.4 in	4.5 pounds
Rib	Fiberglass	62 inches	1 1/4 in	1/4 in	1 pound
Light	[none]	n/a	n/a	n/a	n/a

**Test 7. Little Buster Sign Stand with 1220 x 1220 mm (48 x 48 inch) Roll Up Sign mounted 610 mm (24 inches) above ground**

An “X-footprint” portable sign stand with a telescoping mast supporting the diamond warning sign, topped by a flag bracket. This stand was tested with the mast completely lowered.

Component	Material	Height to top	Width	Thickness	Weight
Base	Steel	16 inches	2.5 inches	0.250 wall	30 pounds
Mast	Steel	89 inches	1.2 in	16 ga	6 pounds
Sign	Rollup	89 inches	48x48	0.035 in	4 pounds
Ribs	Fiberglass	n/a	1 1/4 in	V 1/4, H 3/16	2 pounds
Light (none)	[flag bracket]	n/a	n/a	n/a	n/a

**Test 8. Big Buster Dual Spring Folding Leg Sign Stand with 1220 x 1220 mm (48 x 48 inch)**

**2 mm “Reynolite” Reynolds Aluminum Laminate Sign mounted 1525 mm (60 inches).  
Above the Ground with Empco-Lite Model Number 100 Warning Light and Light Bolt  
Heavy Duty Protector**

An “X-footprint” portable sign stand with a telescoping mast supporting the diamond warning sign. This stand was tested with the mast extended with a warning light attached to the top.

Component	Material	Height to top	Width	Thickness	Weight
Base	Steel	18 inches	2.5 in tube	0.25 in wall	38 pounds
Outer Mast	Aluminum	69 inches	1.50 in tube	0.10 in wall	3 pounds
Inner Mast	PVC extrus.	125 inches	1.25 in tube	0.25 in wall	5 pounds
Sign	Al Laminate	125 inches	48x48 in	0.090 in	10 pounds
Light	Empco Lite	131 inches	n/a	n/a	4.5 pounds

**Test 9. Metal Leg Barricade with Steel Folding 14 ga Legs, with Inteplast Rigid Plastic  
Panels, and Empco-Lite Model Number 100 Warning Light and Light Bolt Heavy Duty  
Protector**

An “A-frame” Type I barricade with a second, lower panel added for stability (this panel could be replaced with a standard reflectorized panel, turning this into a Type II barricade.)

Component	Material	Height to top	Width	Thickness	Weight
Base	n/a	n/a	n/a	n/a	n/a
Legs	Hot rolled	44 in	1.2 x 1.3 in	14 ga	12 pounds
Panels	Plastic	36.75 in	8 in x 24 in	0.4 inches	3 pounds
Light	Empco-Lite	53 inches	n/a	n/a	4.5 pounds

**Test 10. Rubber Pole Base with 914 x 914 mm (36x36 inch) Aluminum Sign mounted  
457 mm (18 inches) above the ground**

Component	Material	Height to top	Width	Thickness	Weight
Base	Rubber	3 inches	16 x 18 in	2 in	23 pounds
Mast	Steel tube	66 inches	2 x 2 in	16 ga	15 pounds
Sign	Aluminum	66 inches	36x36	0.080 in	9 pounds
Light	Empco Lite	78 inches	n/a	n/a	4.5 pounds

The following two tests were submitted with your May 5 letter and were labeled “Test 1” and “Test 2” in the Karco report. Here, they are numbered “Test 11” and “Test 12” for continuity purposes of this acceptance letter.

**Test 11. Traffix Stand with Single Spring Universal Sign Support with 1220 x 1220 mm (48 x 48 inch) Roll Up Sign mounted 457 mm (18 inches) above ground**

An "X-footprint" compact portable sign stand with the metal mast extending no higher than the bottom of the diamond warning sign.

Component	Material	Height to top	Width	Thickness	Weight
Base	Steel	9 in	1 3/4 in	12 ga	19 pounds
Mast	Hot rolled	14 in	1 3/4 in	12 ga	1 pound
Sign	Roll up	86 in	48x48 in	0.035 in	4 pounds
Ribs	Fiberglass	86 in	1 1/4 in	V 1/4, H 3/16	2 pounds
Light (none)	n/a	n/a	n/a	n/a	n/a

**Test 12. Big Buster Sign Stand with 1220 x 1220 mm (48 x 48 inch) Aluminum Sign with B-Light on Plastic Flag Support. Sign mounted 1625 mm (64 inches) above ground**

An "X-footprint" portable sign stand with a telescoping mast supporting the diamond warning sign. This stand was tested with the mast extended with a Manual on Uniform Traffic Control Devices (MUTCD) Type B warning light attached to the top.

Component	Material	Height to top	Width	Thickness	Weight
Base	Steel	18 in	2.5 in tube	0.25 in wall	38 pounds
Outer Mast	Al extrusion	69 in	1.50 in tube	0.10 in wall	3 pounds
Inner Mast	PVC extrus.	125 in	1.25 in tube	0.25 in wall	5 pounds
Sign	Aluminum	129 in	48x48 in	0.080 in	16 pounds
Light	Empco Lite	136 in	n/a	n/a	4.5 pounds

**Testing**

Full-scale automobile testing was conducted on the subject Traffix vertical panels and sign stands and barricade. The testing is summarized in the table below. All test vehicles met the weight criteria of NCHRP Report 350 for the 820C vehicles, even though most were older than the 6 year model year limit (which has been sanctioned by FHWA.) Damage to the test vehicles was limited to minor to moderate denting and scratching of the bumpers, hoods, and roofs which is not enumerated in the table as none of those contacts had potential for occupant compartment intrusion. Many impacts showed no contact with the windshield at all. In others, significant windshield cracking at the point of impact was seen, but the cracking did not appear to be severe enough to cause penetration nor extensive enough to block the view of the driver. No windshield impacts caused a hole through the glass. The results of this testing met the FHWA requirements.

Test # and Test Article Name*	Impact Speed (kmh)		Delta V (mps)**	Windshield Damage
	Head-on	90-deg.		
1 Vert. Panel w/ sign	103.00	102.43	0.16	No Contact
2 Vert. Panel w/ light	97.81	96.76	0.30	No Contact
3 Traffix Stand	101.06	99.42	0.50	Moderate cracking

4 Al. Buster Stand	99.67	98.60	0.30	2 in. glass deflection no intrusion
5 Big Buster Stand	98.21	97.47	0.20	Contact, but no damage
6 Zephyr Portable	99.83	99.15	0.19	No Contact
7 Little Buster Stand	94.67	91.07	1.00	Significant cracking, no intrusion
8 Big Buster Stand	99.15	98.37	0.22	No Contact
9 Metal Leg Barricade	104.79	97.15	2.12	No Contact
10 Pole Base w/ sign	98.91	93.16	1.60	Significant cracking, no intrusion
11 TrafFix Stand	97.49	95.42	0.58	Minor cracking
12 Big Buster Stand	96.90	96.56	0.10	No Contact

\* Roll Up signs were used in tests 4, 7, 11. Coreplast signs were used in tests 1, 3, 5, 6. Inteplast barricade panels used in test 9. Reynolds Aluminum Laminate signs were used in test 8. Solid aluminum signs were used in test 10, 11.

\*\* Vehicle velocity (in kilometers per hour) was only recorded at the two impact points. As the test articles in each test were identical except for orientation, the change in velocity (in meters per second) between the first and second impacts is a satisfactory measure of the average delta V due to the impacts.

### Findings

The results of the testing met the FHWA requirements and, therefore, the devices described above and shown in the enclosed drawings for reference are acceptable for use as Test Level 3 devices on the NHS under the range of conditions tested, when proposed by a State.

### Rigid Substrates:

We are finding that the 2 mm thick Alpolite, Reynolite, and Dibond aluminum laminate sign substrates are acceptable alternates. Also, 10 mm (0.4 inch) thick Coreplast and Inteplast corrugated plastic sign substrates are also alternates for each other.

### Type B Warning Lights:

Our guidance prohibits Type B (“high intensity”) warning lights on work zone traffic control devices. Your testing shows that Type B lights can be fabricated no heavier and no more of a hazard than Type A or C lights. Therefore, the restriction against Type B lights that are no larger nor heavier than common Type A or C lights is removed. These lights may be used *where conventional type A or C lights have been successfully tested on work zone devices*. They may not be substituted if the crash test used a “lightweight” warning light (typically an “LED” type or one where the batteries placed at the base and are remote from the lens.)

Please note the following standard provisions which apply to FHWA letters of acceptance:

- Our acceptance is limited to the crashworthiness characteristics of the devices and does not cover their structural features, nor conformity with the MUTCD.
- Any changes that may adversely influence the crashworthiness of the device will require a new acceptance letter.
- Should the FHWA discover that the qualification testing was flawed, that in-service

performance reveals unacceptable safety problems, or that the device being marketed is significantly different from the version that was crash tested, it reserves the right to modify or revoke its acceptance.

- You will be expected to supply potential users with sufficient information on design and installation requirements to ensure proper performance.
- You will be expected to certify to potential users that the hardware furnished has essentially the same chemistry, mechanical properties, and geometry as that submitted for acceptance, and that they will meet the crashworthiness requirements of FHWA and NCHRP Report 350.
- To prevent misunderstanding by others, this letter of acceptance, designated as number WZ-73, shall not be reproduced except in full.
- Many Traffix work zone devices are patented products and considered "proprietary." The use of proprietary work zone traffic control devices in Federal-aid projects is generally of a temporary nature. They are selected by the contractor for use as needed and removed upon completion of the project. Under such conditions they can be presumed to meet requirement "a" given below for the use of proprietary products on Federal-aid projects. On the other hand, if proprietary devices are specified for use on Federal-aid projects, except exempt, non-NHS projects, they: (a) must be supplied through competitive bidding with equally suitable unpatented items; (b) the highway agency must certify that they are essential for synchronization with existing highway facilities or that no equally suitable alternative exists or; (c) they must be used for research or for a distinctive type of construction on relatively short sections of road for experimental purposes. Our regulations concerning proprietary products are contained in Title 23, Code of Federal Regulations, Section 635.411, a copy of which is enclosed.

Sincerely yours,

Frederick G. Wright, Jr.  
Program Manager, Safety

Enclosure

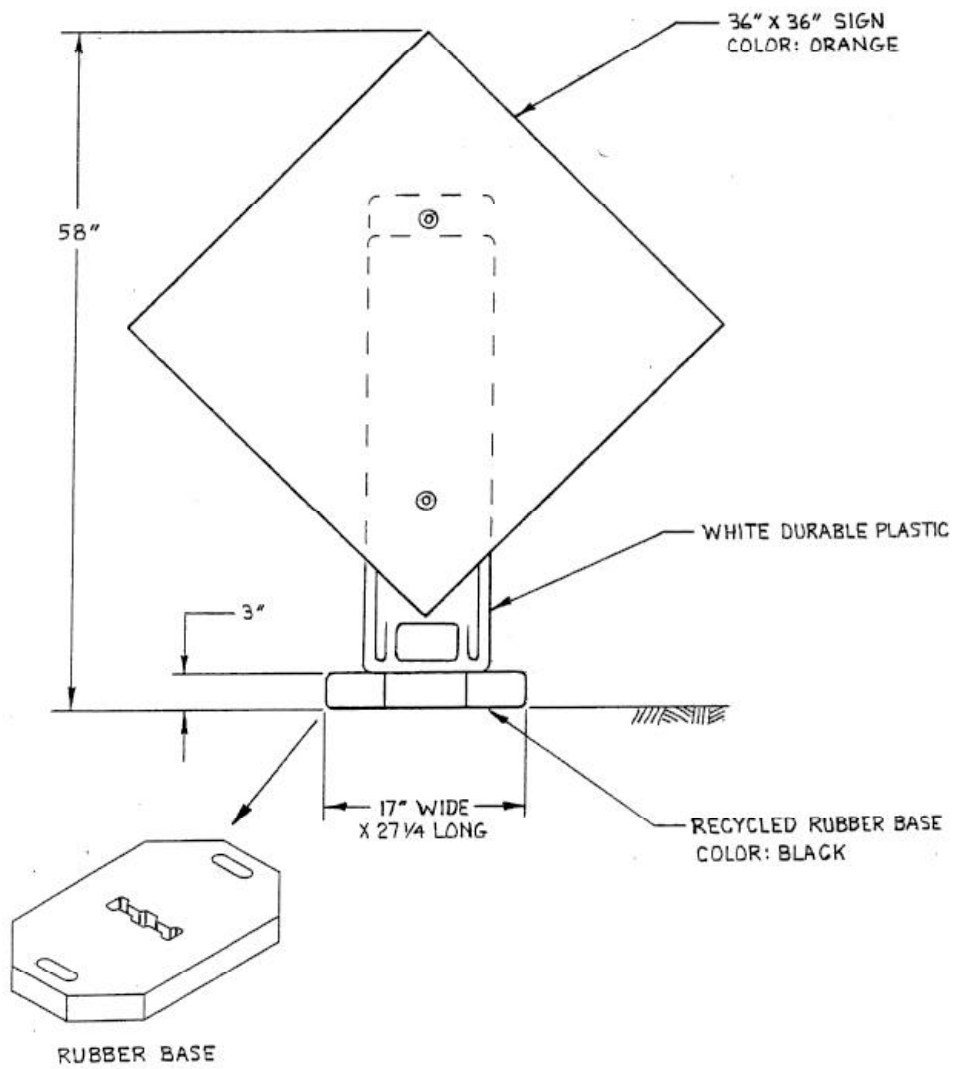



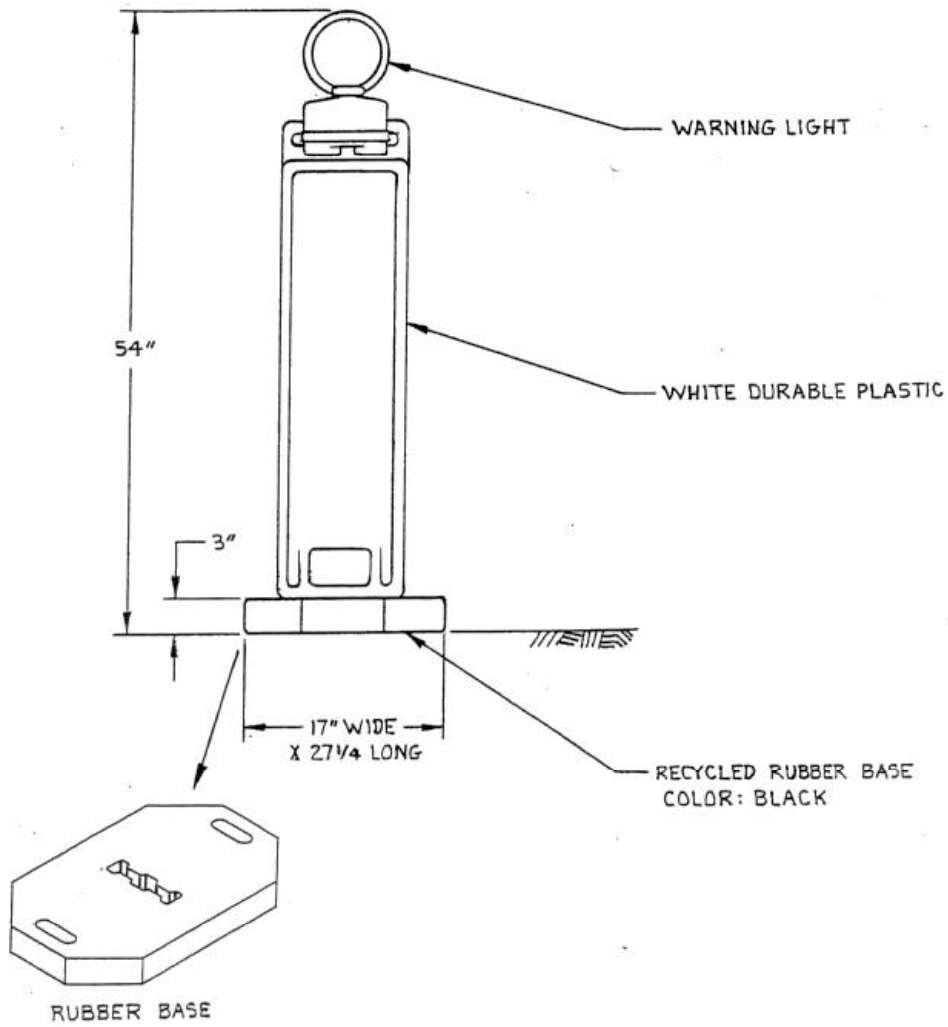

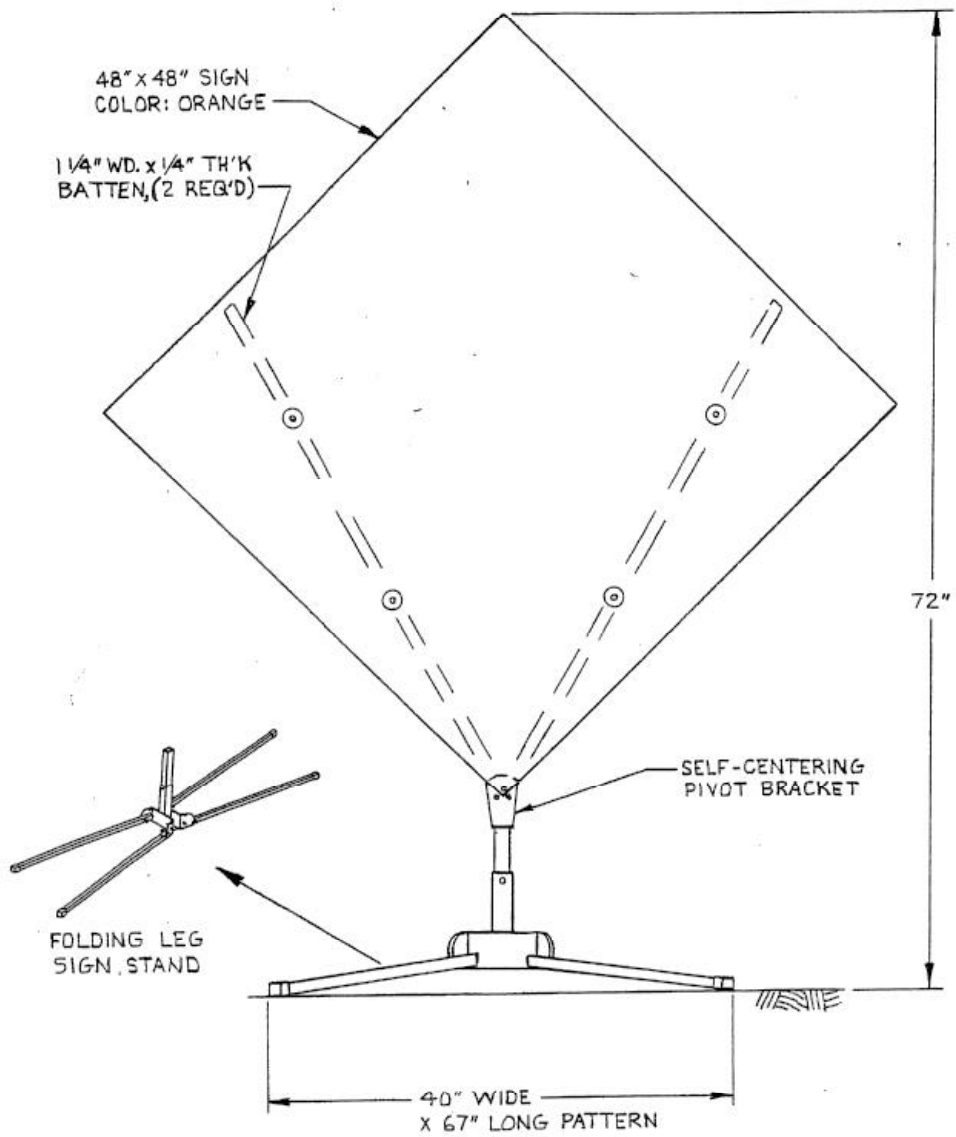

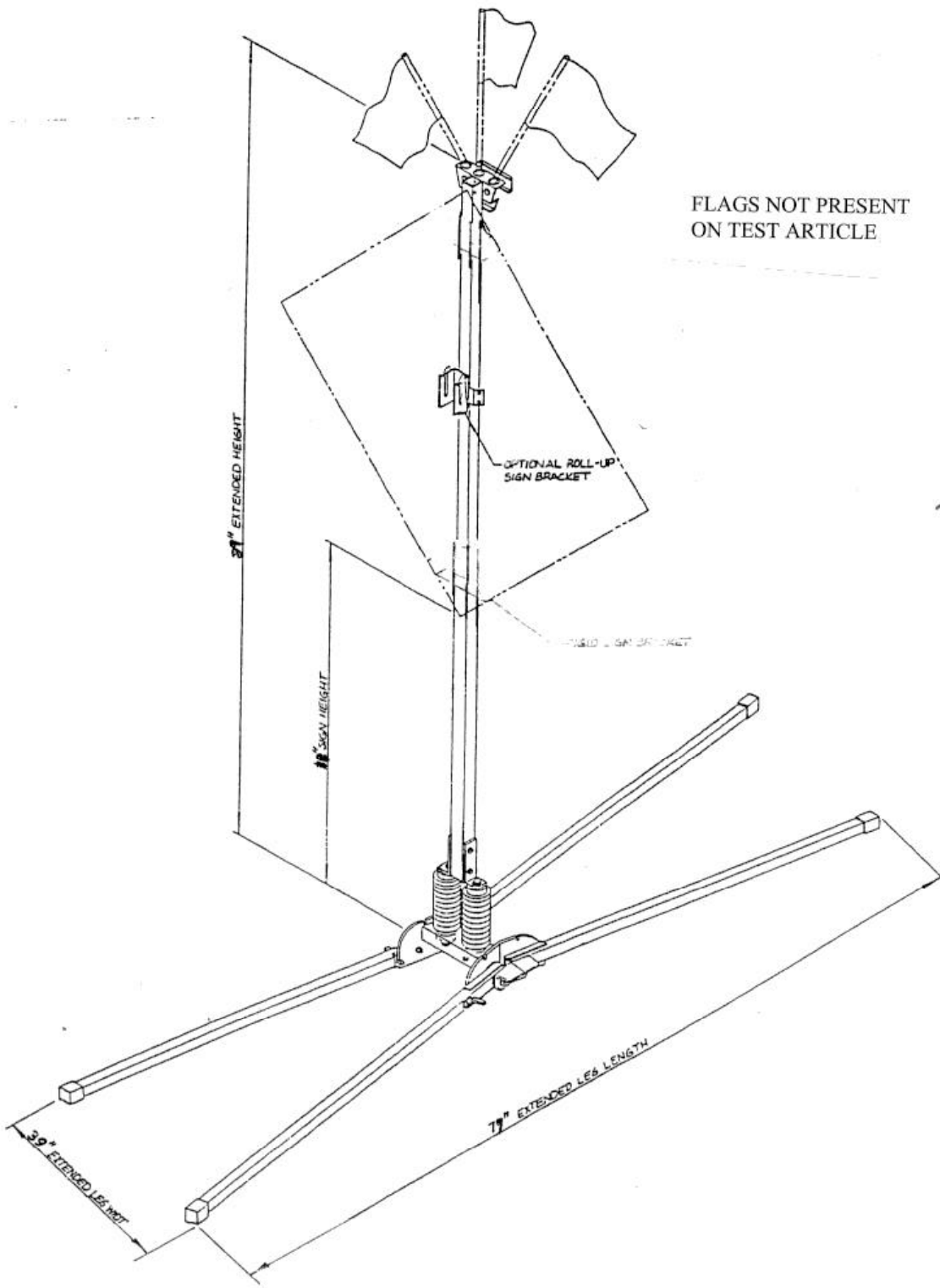

FLAGS NOT PRESENT  
ON TEST ARTICLE

TRAFFIX ALUMINUM BUSTER DUAL SPRING FOLDING LEG SIGN STAND

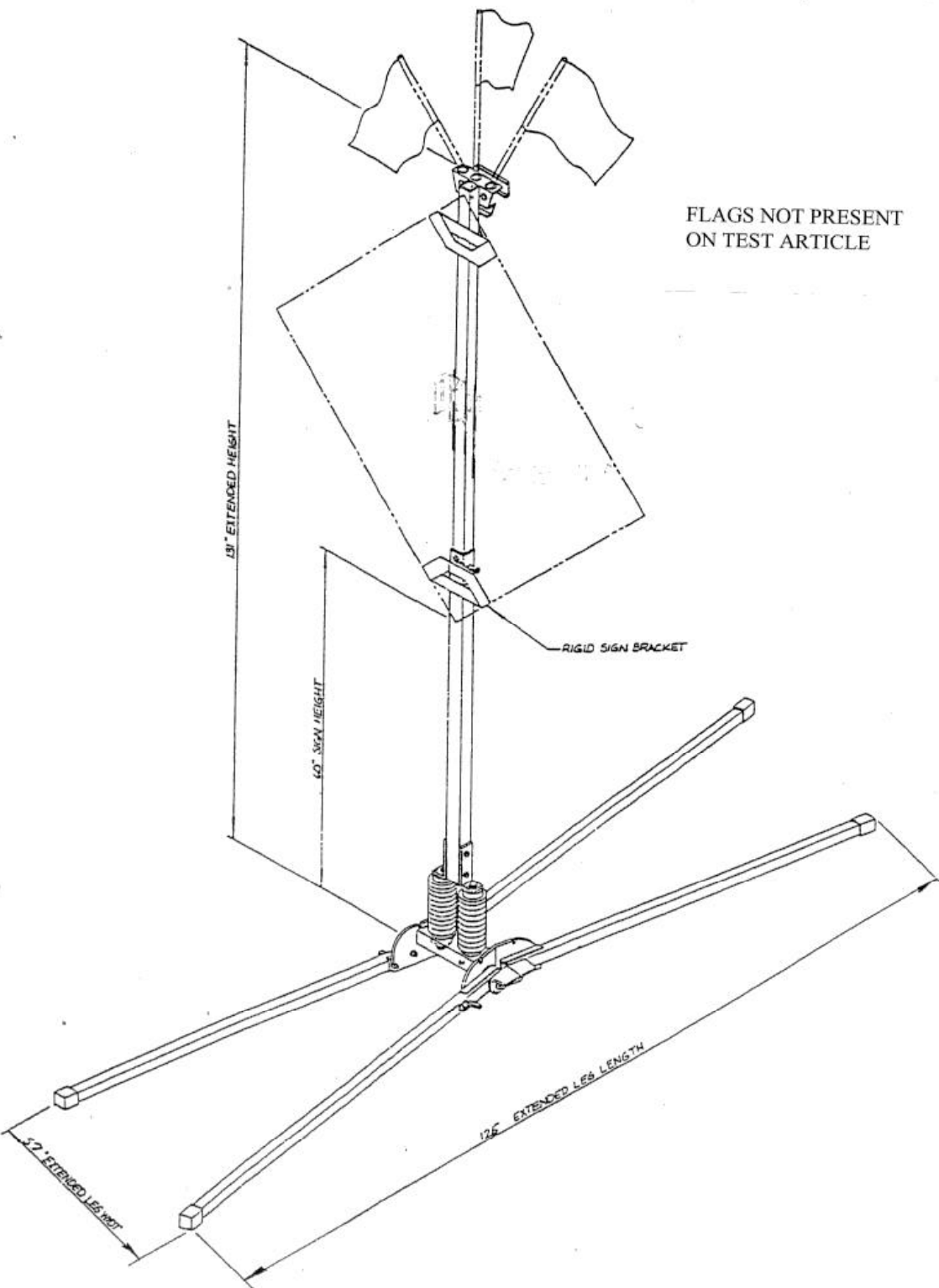

FLAGS NOT PRESENT  
ON TEST ARTICLE

RIGID SIGN BRACKET

131" EXTENDED HEIGHT

60" MAX HEIGHT

126" EXTENDED LEG LENGTH

122" EXTENDED LEG WIDTH

TRAFFIX BIG BUISTER DUAL SPRING FOLDING LEG SIGN STAND

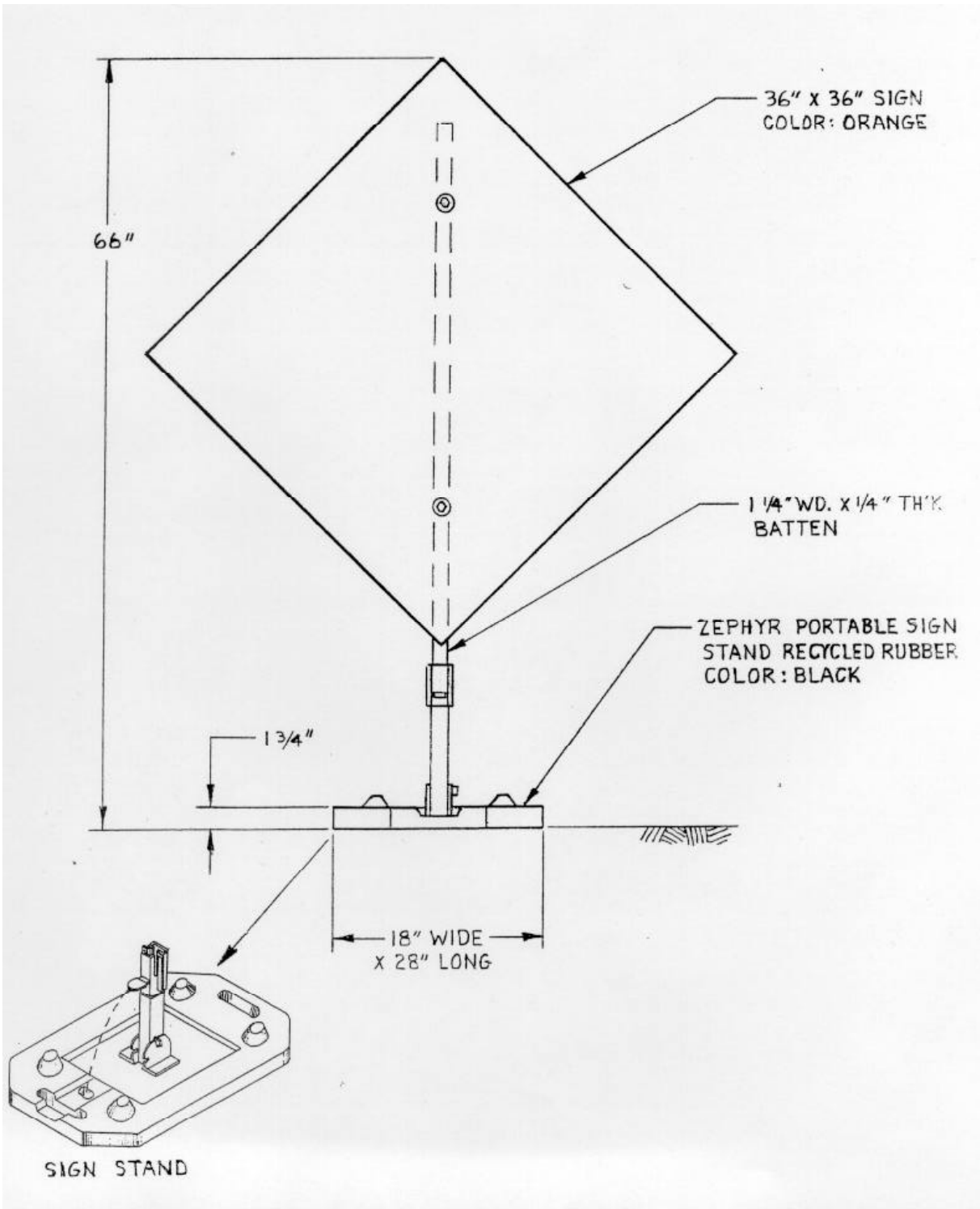

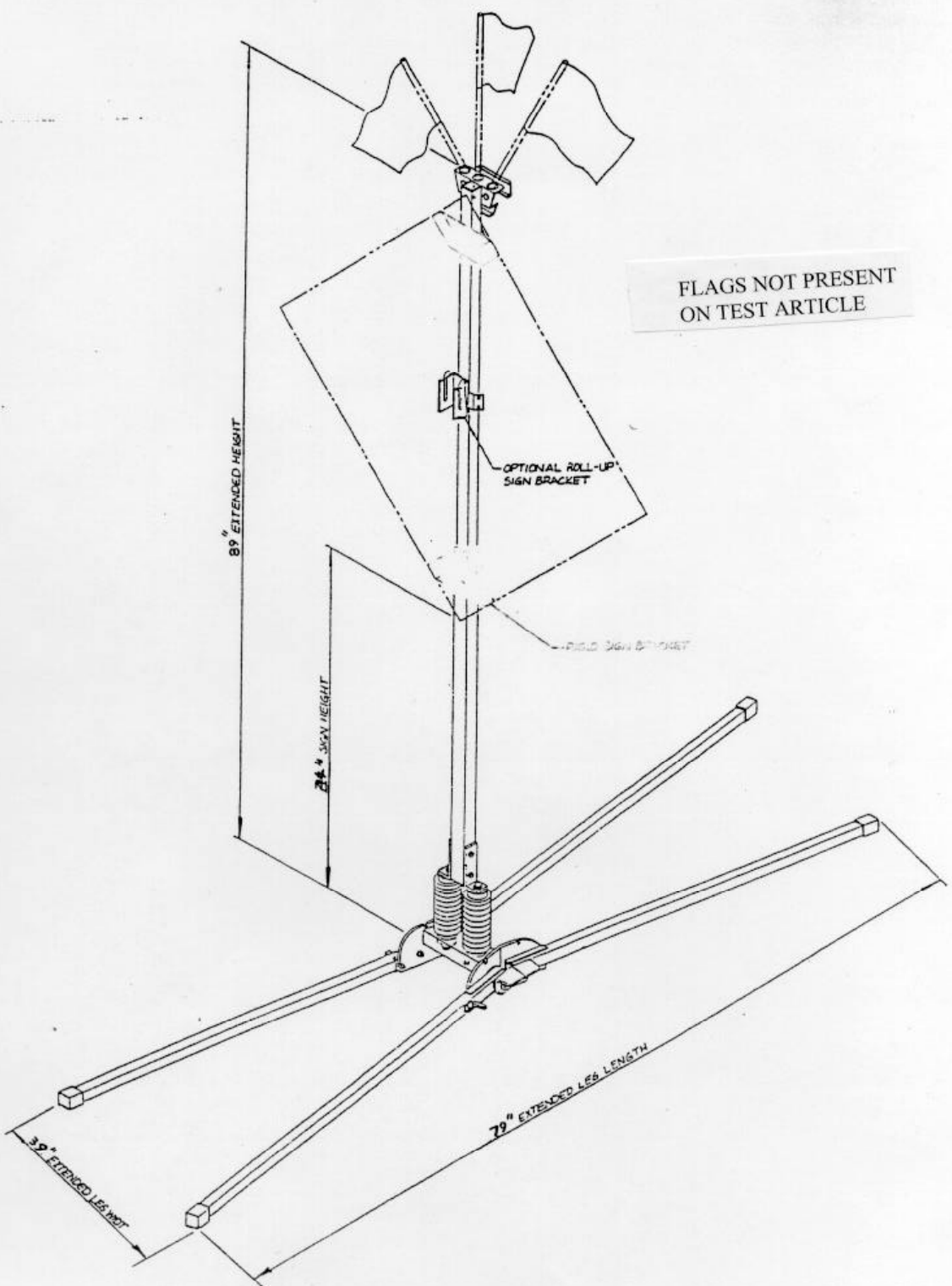

FLAGS NOT PRESENT  
ON TEST ARTICLE

OPTIONAL ROLL-UP  
SIGN BRACKET

FIELD SIGN BRACKET

89" EXTENDED HEIGHT

24" SIGN HEIGHT

79" EXTENDED LEG LENGTH

39" EXTENDED LEG WIDTH

TRAFFIX LITTLE BUSTER DUAL SPRING FOLDING LEG SIGN STAND



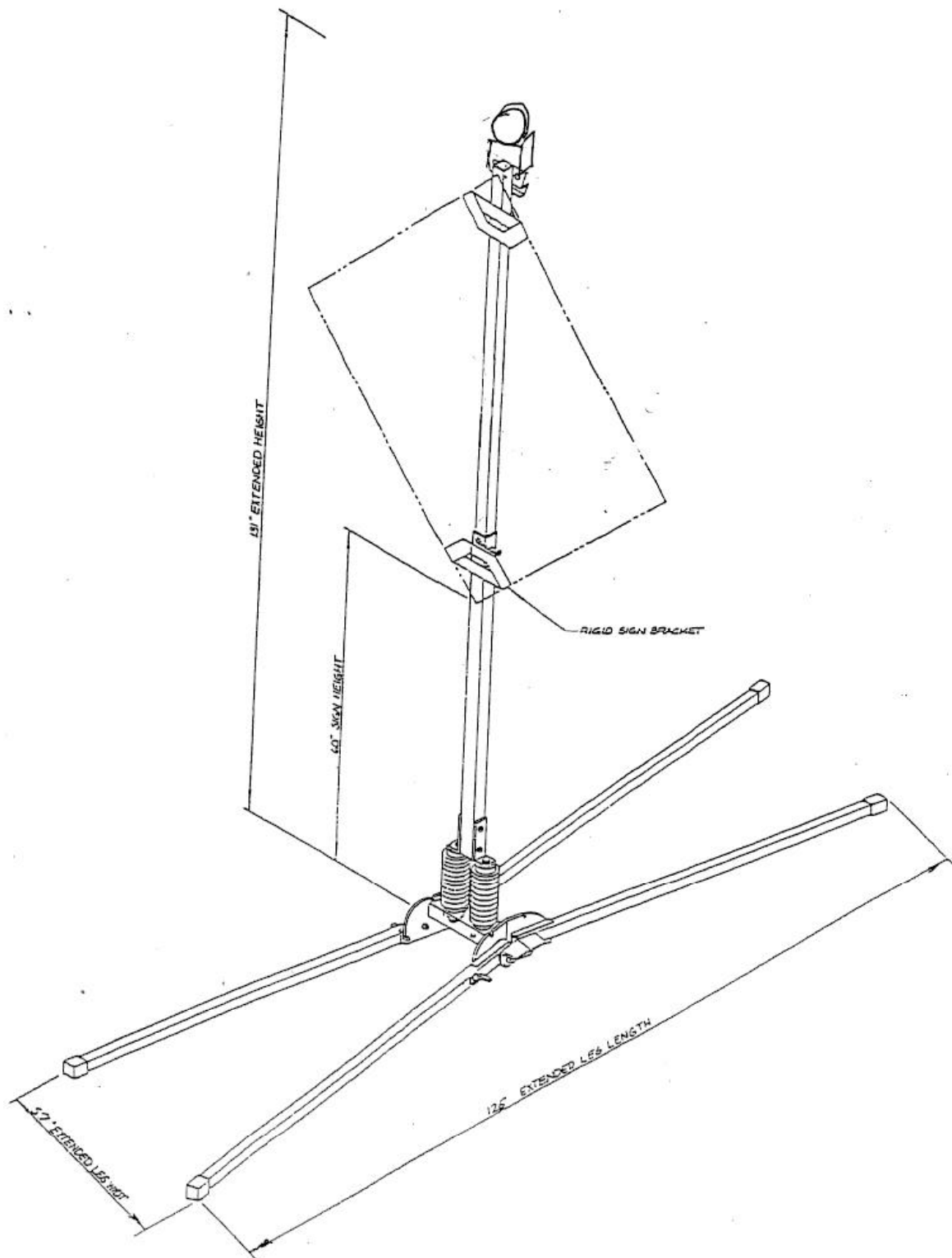

TRAFFIX BIG BUSTER DUAL SPRING FOLDING LEG SIGN STAND



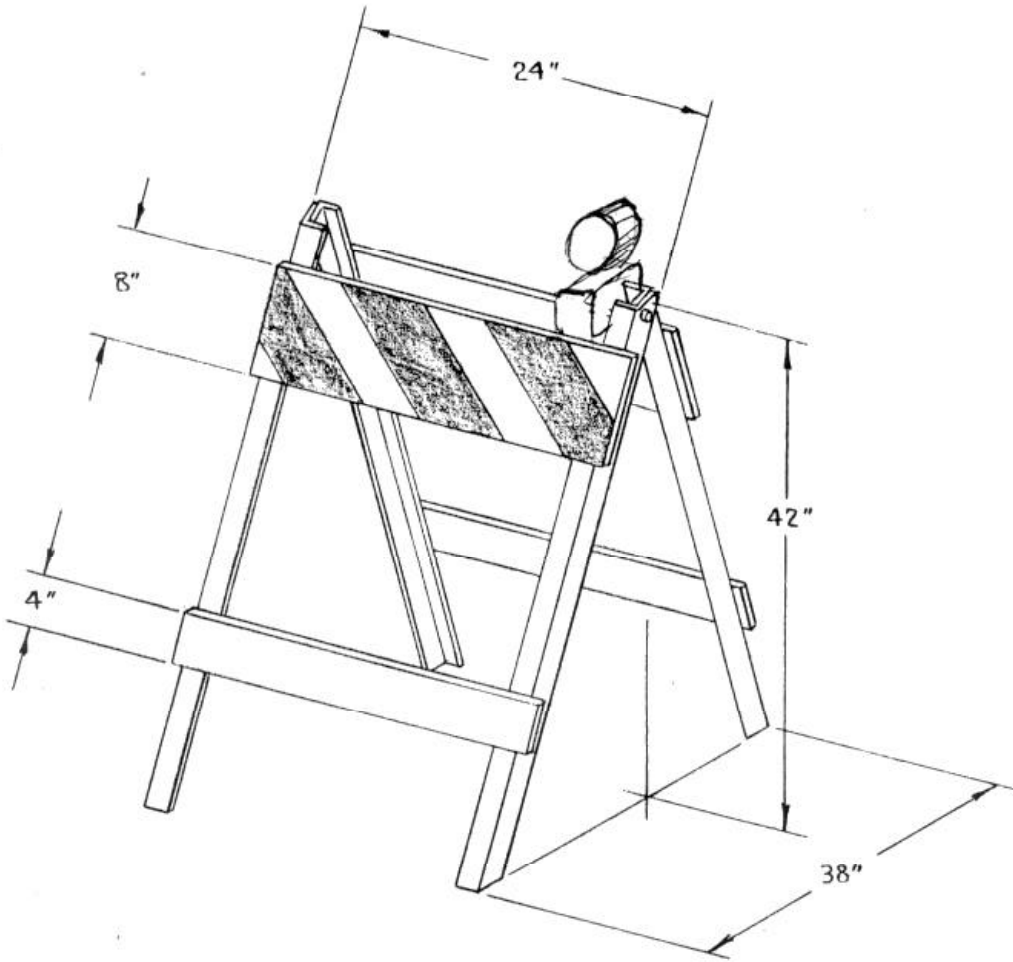

METAL LEG FOLDING BARRICADE

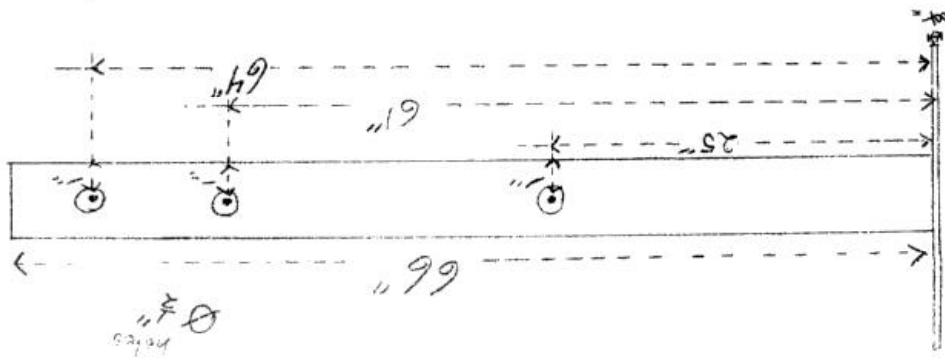
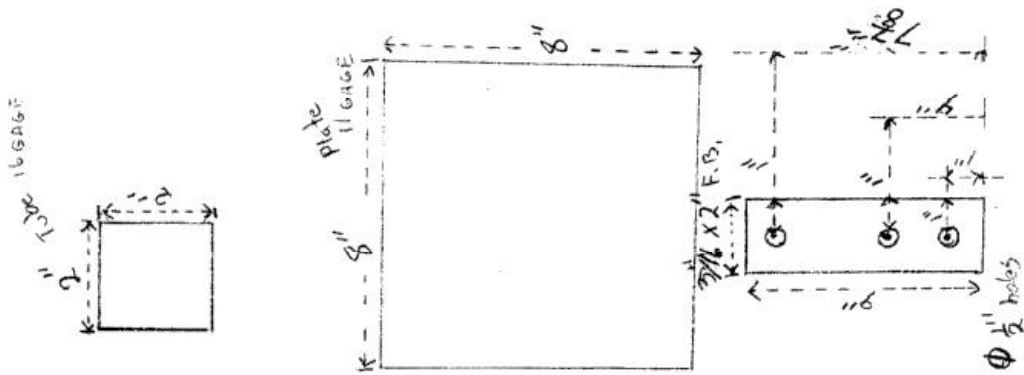
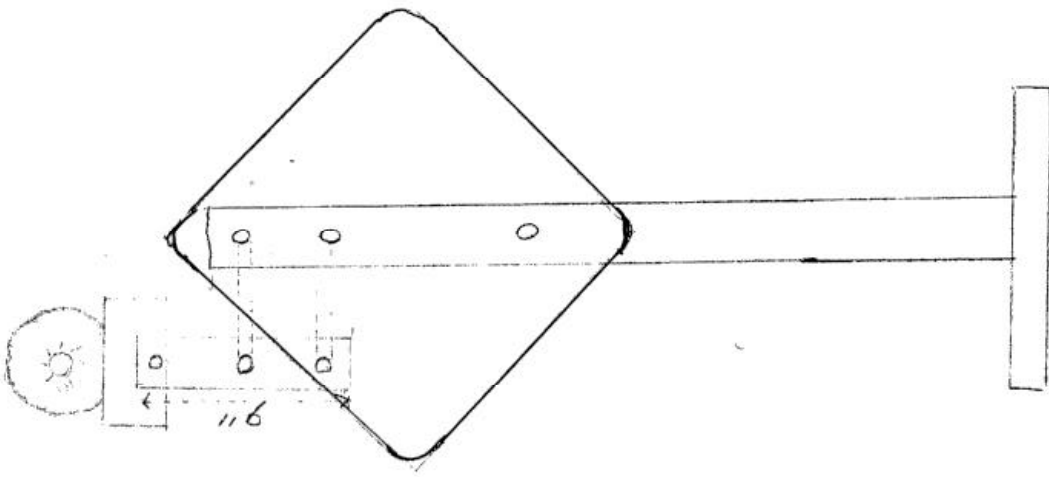

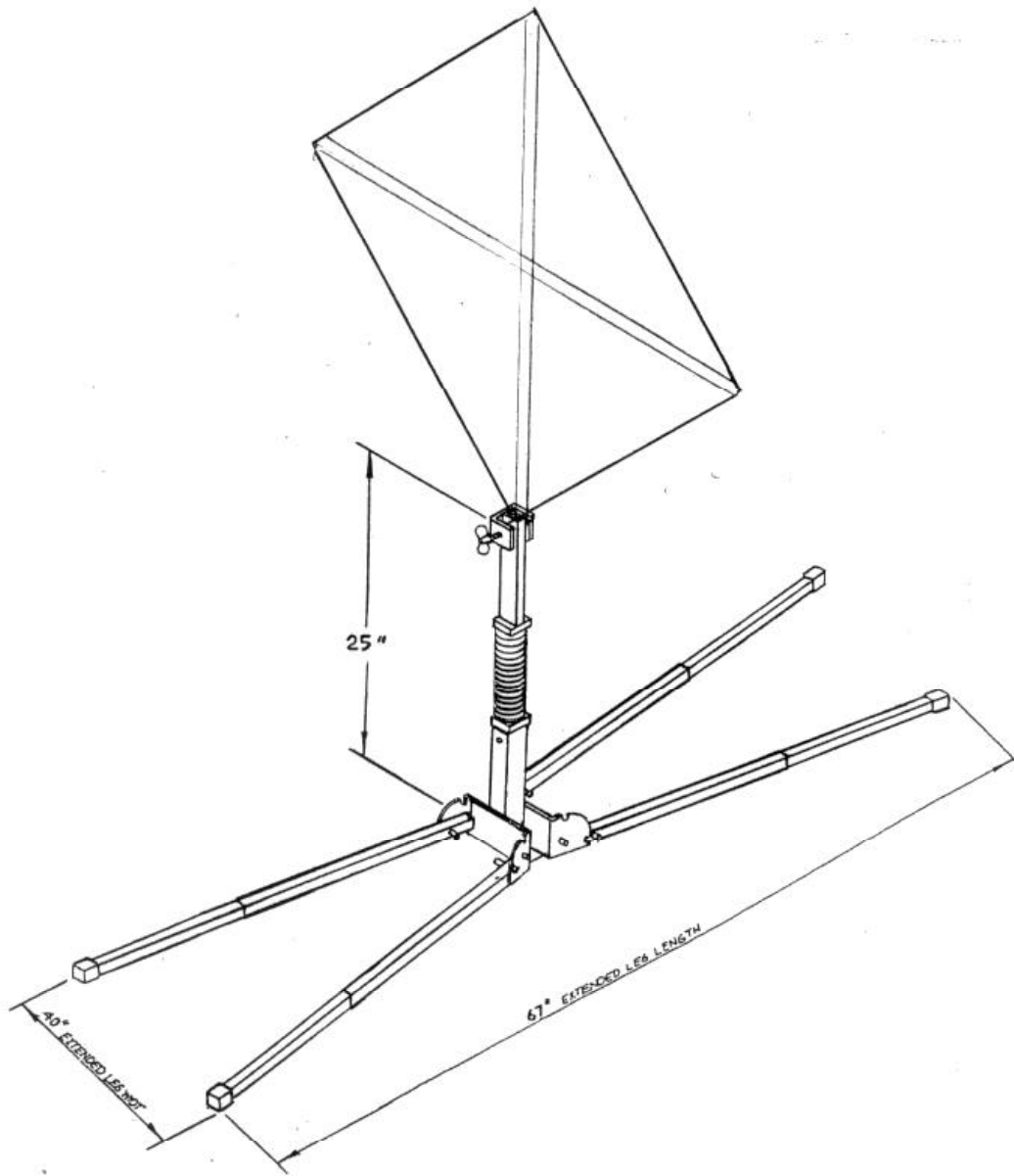

TRAFFIX STAND WITH SINGLE SPRING

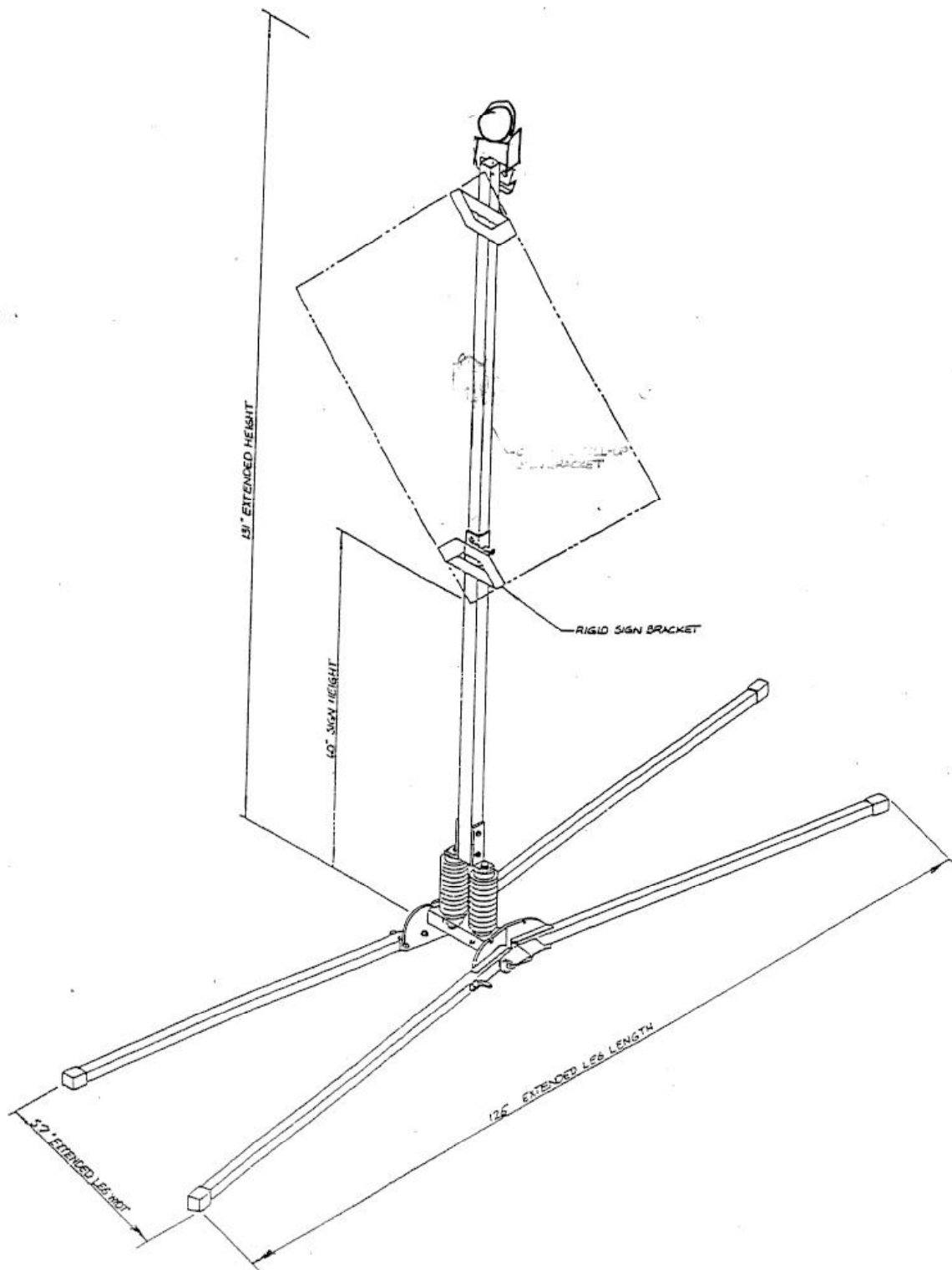

TRAFFIX BIG BUSTER DUAL SPRING FOLDING LEG SIGN STAND

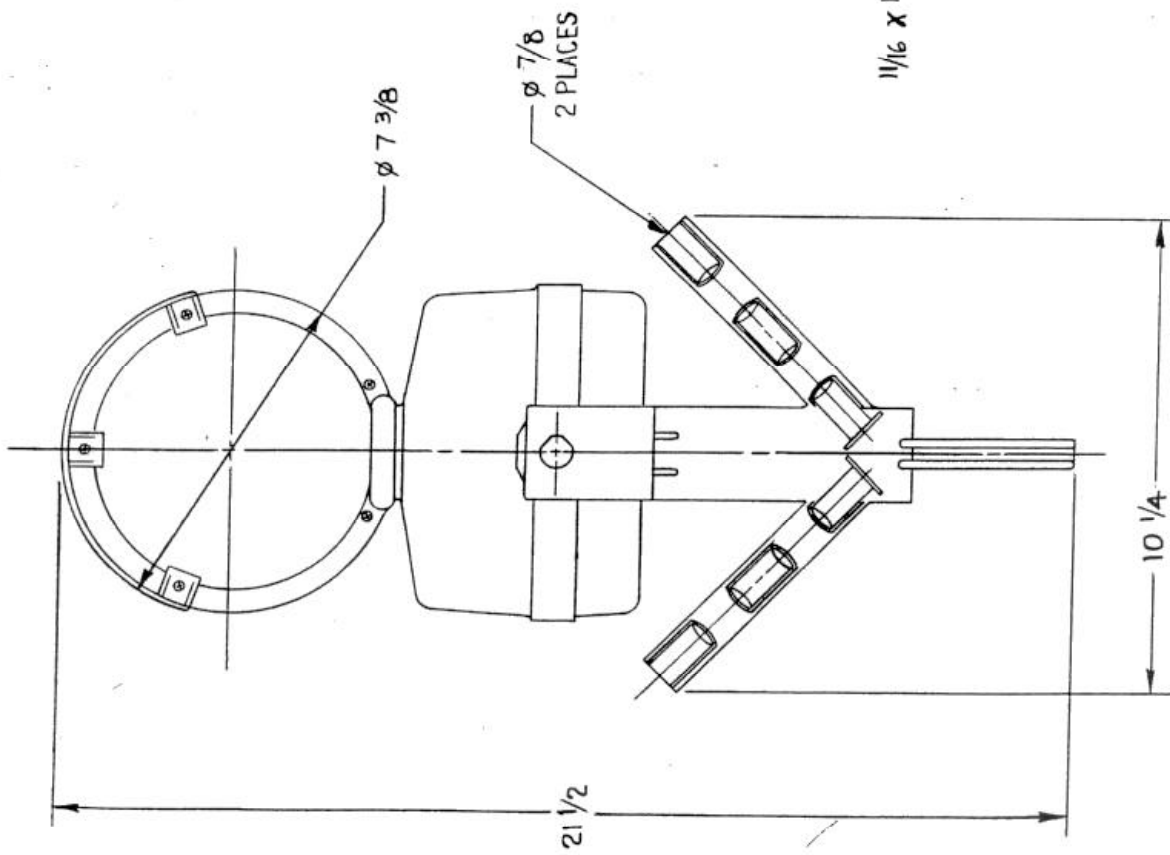
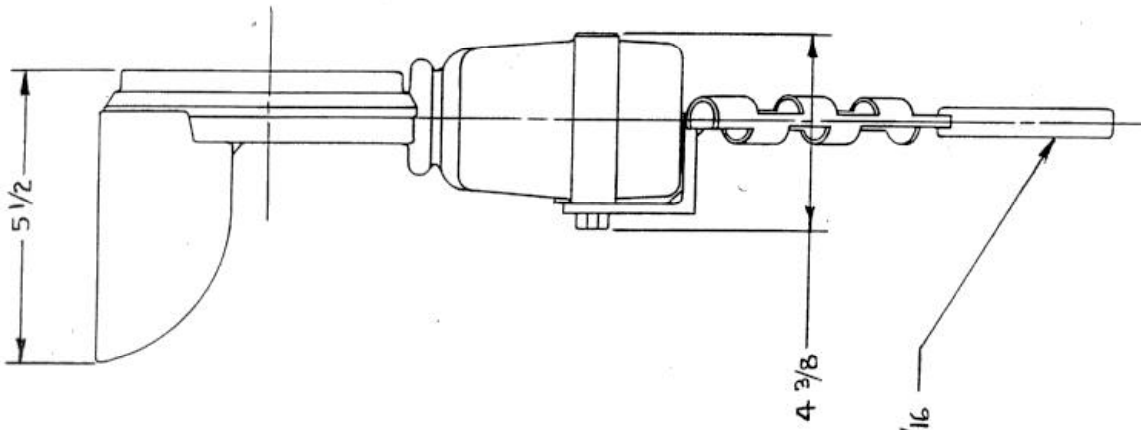

Sec. 635.411 Material or product selection.

(a) Federal funds shall not participate, directly or indirectly, in payment for any premium or royalty on any patented or proprietary material, specification, or process specifically set forth in the plans and specifications for a project, unless:

(1) Such patented or proprietary item is purchased or obtained through competitive bidding with equally suitable unpatented items; or

(2) The State highway agency certifies either that such patented or proprietary item is essential for synchronization with existing highway facilities, or that no equally suitable alternate exists; or

(3) Such patented or proprietary item is used for research or for a distinctive type of construction on relatively short sections of road for experimental purposes.

(b) When there is available for purchase more than one nonpatented, nonproprietary material, semifinished or finished article or product that will fulfill the requirements for an item of work of a project and these available materials or products are judged to be of satisfactory quality and equally acceptable on the basis of engineering analysis and the anticipated prices for the related item(s) of work are estimated to be approximately the same, the PS&E for the project shall either contain or include by reference the specifications for each such material or product that is considered acceptable for incorporation in the work. If the State highway agency wishes to substitute some other acceptable material or product for the material or product designated by the successful bidder or bid as the lowest alternate, and such substitution results in an increase in costs, there will not be Federal-aid participation in any increase in costs.

(c) A State highway agency may require a specific material or product when there are other acceptable materials and products, when such specific choice is approved by the Division Administrator as being in the public interest. When the Division Administrator's approval is not obtained, the item will be nonparticipating unless bidding procedures are used that establish the unit price of each acceptable alternative. In this case Federal-aid participation will be based on the lowest price so established.

(d) Appendix A sets forth the FHWA requirements regarding (1) the specification of alternative types of culvert pipes, and (2) the number and types of such alternatives which must be set forth in the specifications for various types of drainage installations.

(e) Reference in specifications and on plans to single trade name materials will not be approved on Federal-aid contracts.

ENCLOSURE 2