



U.S. Department  
of Transportation  
**Federal Highway  
Administration**

400 Seventh St., S.W.  
Washington, D.C. 20590

Refer to: HSA-1\WZ-59

Jan D. Miller  
Eastern Metal/USA Sign  
1430 Sullivan Street  
Elmira, NY 14901-1698

Dear Mr. Miller:

Thank you for your letter of September 14 requesting Federal Highway Administration (FHWA) acceptance of your company's portable sign stands and barricades as crashworthy traffic control devices for use in work zones on the National Highway System (NHS). Accompanying your letter was a video of the crash tests. A report of the testing, conducted by Safety Quest, Inc., was received on October 10. You requested that we find the listed devices acceptable for use on the NHS under the provisions of National Cooperative Highway Research Program (NCHRP) Report 350 "Recommended Procedures for the Safety Performance Evaluation of Highway Features."

### **Introduction**

FHWA guidance on crash testing of work zone traffic control devices is contained in two memoranda. The first, dated July 25, 1997, titled "Information: Identifying Acceptable Highway Safety Features," established four categories of work zone devices: Category I devices were those lightweight devices which could be self-certified by the vendor, Category II devices were other lightweight devices which needed individual crash testing, Category III devices were barriers and other fixed or massive devices also needing crash testing, and Category IV devices were trailer mounted lighted signs, arrow panels, etc. The second guidance memorandum was issued on August 28, 1998, and is titled "INFORMATION: Crash Tested Work Zone Traffic Control Devices." This later memorandum lists devices that are acceptable under Categories I, II, and III.

A brief description of the devices for which you are requesting acceptance follows:

### **Request 1**

- A) The Model E-350 Econo-Stand, Heavy Duty Tripod Style Sign Stand consists of three legs and a mast. The legs, constructed of 32 mm x 32 mm x 2 mm (1.25 inch x 1.25 inch x 16 gage) cold formed galvanized steel tubing, for a tripod. A 25 mm x 25 mm x 2 mm, (1 inch x 1 inch x 16 ga) cold-formed galvanized steel tube mast attaches to the leg assembly. Two steel clips, one on each leg, and a formed steel bracket attached to the top of the mast, support the 1219 mm x x1219 mm (48 inch x 48 inch) rigid corrugated thermoplastic sign.

Steel flag holders mount to the top sign bracket to support vinyl flags. Three 457 mm (18 inch) square vinyl flags on 19 mm x 613 mm (0.8 inch x 24 inch) wood dowels. The overall height of the E-350 stand with vinyl flags mounted above the sign was 2311 mm (91 inches) and 1867 mm (73.5 inches) without the flags.

Your request was to find this stand acceptable with:

- 1219 mm or smaller Reflexite Endurance corrugated thermoplastic signs.
- 1219 mm or smaller Polyethylene/Polypropylene 10 mm corrugated PVC plastic panel signs.

- B) The Model E-380 Econo-Stand, Heavy Duty Tripod Style Stand for use with 1219 mm and smaller roll-up signs of standard configuration. The E-380 is identical to the E-350 except that it is for roll-up signs only.

## Request 2

Model X-552 Interstate Mid-size spring stand consists of four legs of 25 mm x 25 mm x 1.5 mm, (1 inch x 1 inch x 16 ga) steel tubing. Two vertically mounted steel coil springs are used to attach the base unit to the steel upright. The upright is 25 mm x 25 mm x 1.5 mm (1.25 inch x 1.25 inch x 16 gage) and 20.6 mm x 20.6 mm x 1.5 mm (0.81 inch x 0.81 inch x 16 ga) telescoping steel tubing. The rigid corrugated thermoplastic sign is attached to the mast tube by two formed steel brackets that hold the top and bottom points of the sign. Steel flag holders are mounted to the sign bracket to support vinyl flags. Three flags, similar to those described above, were used. The overall height of the X-552 stand without the flags is 2438 mm (96 inches). The bottom of the sign is 457 mm (18 inches) above ground. Overall footprint of the stand is 914 mm (36 inches) wide x 2032 mm (80 inches) deep.

Your request was to find this stand acceptable with:

- 1219 mm or smaller Reflexite Endurance corrugated thermoplastic signs.
- 1219 mm or smaller Polyethylene/Polypropylene 10 mm corrugated PVC plastic panel.

## Request 3

- A) The MELBA Type III, "Long Board" All Plastic Barricade is composed of three major components; two skids, two uprights, and three horizontal panels. The panels are reinforced hollow recycled PVC plastic. The dimensions of the panels are 32 mm x 232 mm x 3658 mm (1.25 x 9.13 x 144 inches). The panels attach to 76 mm x 76 mm x 3 mm (3 x 3 x 0.1 inch) PVC posts. Each post is sleeved with 64 mm (2.5 inch) diameter schedule 40 PVC pipe. Three 0.4 in (10 mm) bolts secure each end of the rail to the posts. The panels mount such that the center of the bottom panel is 508 mm (20 inch) above grade, and the top panel is 1524 mm (60 inches) above grade.

The two skids are mounted transversely to the panels. Each skid is two hollow reinforced PVC panels similar to the barricade panels. The dimensions of the skids are 32 mm x 152 mm x 1829 mm (1.25 x 6 x 72 inches). The overall weight of the MELBA barricade as tested is 45 kg (99 pounds).

You requested this barricade with the following options:

- With 3 recycled PVC planks of 3660 mm, 3050 mm, 2440 mm, 1830 mm, 1220 mm (12, 10, 8, 6, 4 feet) lengths.
  - With 1525 mm x 1219 mm (60 x 48 inch), 1525 mm (60 inch), 1mm (48 inch) or smaller Reflexite Endurance or Polyethylene / Polypropylene corrugated plastic and roll-up signs substrates.
- B) Melba Recycled PVC Plastic planks for use on accepted perforated square steel tubing with or without mounting a 1219-mm or smaller sign on the above substrates.

#### **Request 4**

Model X-602 Wind Deflecting Interstate Sign Stand has four legs of 25 mm x 25 mm x 302 mm (1 inch x 1 inch x 0.125 inch) 6061-T6 extruded aluminum tubing. Coil springs are used to attach the base unit to the 32 mm x 32 mm x 0.125 mm (1.25 inch x 1.25 inch x 0.125 inch) and 25 mm x 25 mm x 3.2 mm (1 inch x 1 inch x 0.125 inch) telescoping aluminum tube upright. Steel flag holders are mounted to the top sign bracket to support vinyl flags. Three flags, similar to those described above, were used.

The overall height of the X-602 stand is 3962 mm (156 inches) with the flags and 3454 mm (136 inches) without the flags. The bottom of the sign is 1524 mm (60 inches) above grade. The total weight of the stand is 23.6 kg (52 pounds) without the Endurance sign and is 28.6 kg (63 pounds) with the sign.

You requested acceptance for the following sign substrates and 3 wood dowel flags:

- 1219 mm or smaller diamond shaped corrugated thermoplastic signs.
- 1219 mm or smaller diamond polyethylene / Polypropylene corrugated plastic.
- With 1525 mm x 1219 mm (60 x 48 inch), 1525 mm (60 inch), 1219 mm (48 inch) or smaller Reflexite Endurance or Polyethylene / Polypropylene corrugated plastic and roll-up signs substrates.

#### **Request 5**

- A) The Model X-842 Non-deflecting Interstate Sign Stand consists of four legs of 25 mm x 25 mm x 1.5 mm (1 inch x 1 inch x 16 ga.) cold-formed, galvanized steel tubing. The legs attach to a formed steel base. The stand mast, constructed of 25 mm x 25 mm x 1.5 mm (1 inch x 1 inch x 16 ga) and 21 mm x 21 mm x 1.5 mm (0.81 inch x 0.81 inch x 16 ga) telescoping galvanized steel tubing, bolts to the base. Three flags, similar to those described above, were used.

The overall height of the X-842 stand with flags is 2692 mm (106 inches) and without flags is 2197 mm (86.5 inches). The height to the bottom of the sign is 381 mm (15 inches) above grade. The total weight of the stand is 10.9 kg (24 pounds) with the sign and 15.9 kg (35 pounds) without the sign.

You requested that this stand be accepted with:

- 1219 mm diamond or smaller Reflexite Endurance corrugated thermoplastic sign.
- 1219 mm diamond or smaller Polyethylene / Polypropylene corrugated plastic.

- B) Model X-841 Mid size sign for use with 1219 mm or smaller roll-up signs and 3 wood dowel flags.

## **Testing**

Full-scale automobile testing was conducted on your company's sign stands and barricades. In most tests, two stand-alone examples of the device were tested in tandem, one head-on and the next placed six meters downstream turned at 90 degrees, as called for in our guidance memoranda. In other tests, devices were tested either head on or at 90 degrees depending upon the test needed to finish qualifying of the system. The complete devices as tested are shown in Enclosure 1. The crash tests are summarized in Enclosure 2.

## **Findings**

In test number EM-20 the Endurance panel impacted the test vehicle and remained flat against the windshield until impact with the second stand. The mast of the second stand then struck the back of the sign panel on the windshield, resulting in extensive cracking and excessive deformation to the glass. No holes were made through the glass. Our concern was that the Endurance panels, when impacting flat against the windshield, caused so much cracking that the driver could not see. We were also concerned that the impact caused deformation of the windshield in excess of 2 inches. When you discussed this matter with Mr. Nicholas Artimovich you indicated that the second impact caused the extensive damage. Because the video footage was inconclusive, you and Mr. Artimovich agreed that another test was in order to clarify the performance of the head-on installation. You provided video footage of a subsequent test that showed the Endurance panel, mounted at the same height on a flexible base x-footprint stand, striking the windshield with little damage. It seems, therefore, that the extensive damage seen in the first test resulted from the interaction of the second sign support, a situation unlikely to be found in real-world installations.

Otherwise, damage to the vehicle occurred to the bumper, grill, hood, windshield, and roof. In most cases, windshield damage was slight to moderate. The test articles did not show potential for penetrating the occupant compartment. The results of this testing met the FHWA requirements and, therefore, the devices listed below are acceptable for use as Test Level 3 devices on the NHS under the range of conditions tested, when proposed by a state.

## **Request 1**

- A) The Model E-350 Econo-Stand, Heavy Duty Tripod Style Sign Stand with:  
 -1219 mm or smaller Reflexite Endurance corrugated thermoplastic signs.  
 -1219 mm or smaller Polyethylene/Polypropylene 10 mm corrugated PVC plastic panel signs.
- B) The Model E-380 Econo-Stand, Heavy Duty Tripod Style Stand for use with 1219 mm and smaller roll-up signs of standard configuration.

**Request 2**

Model X-552 Interstate Mid-size spring stand with:

- 1219 mm or smaller Reflexite Endurance corrugated thermoplastic signs.
- 1219 mm or smaller Polyethylene/Polypropylene 10 mm corrugated PVC plastic panel

**Request 3**

A) The MELBA Type III, "Long Board" All Plastic Barricade with the following options:

- With 3 recycled PVC planks of 3660 mm, 3050 mm, 2440 mm, 1830 mm, 1220 mm (12, 10, 8, 6, 4 feet) lengths
- With (60 x 40 inch), 60 inch, 40 inch or smaller Reflexite Endurance or Polyethylene / Polypropylene corrugated plastic and roll-up signs substrates.

B) Melba Recycled PVC Plastic planks for use on accepted perforated square steel tubing with or without mounting a 1219-mm or smaller sign on the above substrates.

**Request 4**

Model X-602 Wind Deflecting Interstate Sign with the following sign substrates and 3 wood dowel flags:

- 1219 mm or smaller diamond shaped Reflexite Endurance corrugated thermoplastic signs.
- 1219 mm or smaller diamond polyethylene/Polypropylene corrugated plastic.
- Provisionally acceptable (see below) with 1525 mm x 1219 mm (60 x 48 inch), 1525 mm (60 inch), 1219 mm (48 inch) or smaller Reflexite Endurance or Polyethylene/Polypropylene corrugated plastic and roll-up signs substrates.

**Request 5**

A) The Model X-842 Non-deflecting Interstate Sign with:

- 1219 mm diamond or smaller Reflexite Endurance corrugated thermoplastic sign.
- 1219 mm diamond or smaller Polyethylene / Polypropylene corrugated plastic.

B) Model X-841 Mid size sign for use with 1219 mm or smaller roll-up signs and 3 wood dowel flags.

Tests conducted with the Reflexite "Endurance" substrate signs show satisfactory performance of your stands with this moderate weight, "rigid" plastic substrate. The "polyethylene / polypropylene corrugated plastic signs" are thinner, lighter, and more flexible than the "Endurance" material and should have less of a potential to damage the windshield of impacting vehicles. Bolts, nuts, and washers shall be the same as those used in the tests.

All tests were conducted with diamond shaped warning signs. You requested that these 1219 mm x 1219 mm signs, and smaller signs, be accepted. We consider 915 mm x 915 mm diamond signs to be acceptable by virtue of this crash testing. However, we have not yet established that signs of

different shapes will perform as well as, or better than, the diamond signs. There is an effort underway at this time to examine the question of crashworthiness for temporary sign shapes other than those tested. Until this question is resolved, this letter finds your sign stands provisionally acceptable with other sign shapes. If it is later determined that the testing already conducted is not the "worst case scenario" additional testing may be required.

Please note the following standard provisions that apply to FHWA letters of acceptance:

- Our acceptance is limited to the crashworthiness characteristics of the devices and does not cover their structural features, nor conformity with the Manual on Uniform Traffic Control Devices.
- Any changes that may adversely influence the crashworthiness of the device will require a new acceptance letter.
- Should the FHWA discover that the qualification testing was flawed, that in-service performance reveals unacceptable safety problems, or that the device being marketed is significantly different from the version that was crash tested, it reserves the right to modify or revoke its acceptance.
- You will be expected to supply potential users with sufficient information on design and installation requirements to ensure proper performance.
- You will be expected to certify to potential users that the hardware furnished has essentially the same chemistry, mechanical properties, and geometry as that submitted for acceptance, and that they will meet the crashworthiness requirements of FHWA and NCHRP Report 350.
- To prevent misunderstanding by others, this letter of acceptance, designated as number WZ-59, shall not be reproduced except in full.

All or parts of your company's sign stands and barricades are patented products and considered "proprietary." The use of proprietary work zone traffic control devices in Federal-aid projects is generally of a temporary nature. They are selected by the contractor for use as needed and removed upon completion of the project. Under such conditions they can be presumed to meet requirement "a" given below for the use of proprietary products on Federal-aid projects. On the other hand, if proprietary devices are specified for use on Federal-aid projects, except exempt, non-NHS projects, they: (a) must be supplied through competitive bidding with equally suitable unpatented items; (b) the highway agency must certify that they are essential for synchronization with existing highway facilities or that no equally suitable alternative exists or; (c) they must be used for research or for a distinctive type of construction on relatively short sections of road for experimental purposes. Our regulations concerning proprietary products are contained in Title 23, Code of Federal Regulations, Section 635.411, a copy of which is enclosed.

Sincerely yours,

Frederick G. Wright, Jr.  
Program Manager, Safety

3 Enclosures

# Product Specification Sheet



## E-350/380 Series Sign Stand

Description: Eastern **Metal/USA-SIGN E-350** Econo Stand, Tripod Style Sign Stand with a 3 flag holder permanently attached to the mast. (Tested units had three wooden dowel flags in the flag holder.)

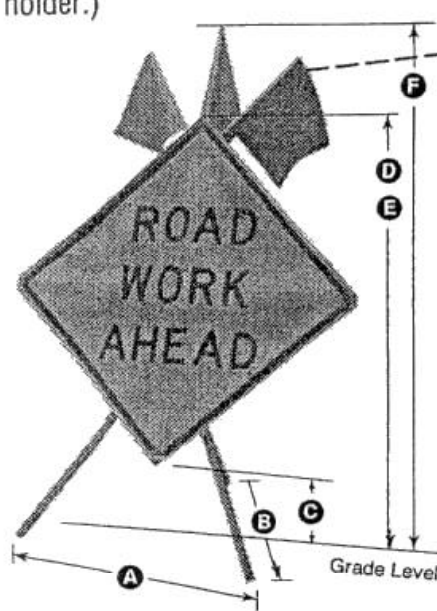

FROV-118/24\* 18" Square fluorescent vinyl flags on 24" x 3/4" wooden staffs.  
Individual Flag Weight: ..... 0.4 lbs

### E-350 with a Reflexite® Endurance™ Sign

#### Material/Construction Features:

Signs: High performance thermoplastic sign with high visibility retro-reflective sheeting. The sign is held on the stand by rigid sign holders permanently mounted to the sign stand, no other hardware is mounted to the sign.

48-EFR\* 48" Endurance Sign, (16 s.f.) Total Weight: 11.0 lbs

36-EFR 36" Endurance Sign, (9 s.f.) Total Weight: 9.2 lbs

#### E-380 Roll-up Sign Material/Construction Features:

Roll-up Signs: All Fabrics, w/ 3/16" or 5/16" thick Horizontal and 3/8" thick Vertical Fiberglass Cross Braces, lexan pockets and washers. With exception of hardware, no other metal parts are used.

48-\* 48" Roll-up Sign, (16 s.f.) Total Weight: 5.55 lbs

36- 36" Roll-up Sign, (9 s.f.) Total Weight: 3.63 lbs

Model Number	Description	Weight	Fully Extended Foot Print		Height Above Grade Level			
			Width <b>A</b>	Depth <b>B</b>	Bottom of Sign <b>C</b>	Top of Mast <b>D</b>	Top of Sign <b>E</b>	Top of Flag <b>F</b>
E-350*	Series Standard Steel Tripod Stand for Rigid Signs	17.5 lbs	48"	47-1/2"	15"	73-1/2"	73"	91"
E-380	(Same) Steel Tripod with additional roll-up sign bracket	18.5 lbs	48"	47-1/2"	15"	73-1/2"	73"	91"

#### Stand Material/Construction Features:

Stand Tubing: 16 ga. Cold-formed galvanized 1-1/4", and 1" tubing ASTM-A500 Rated Steel.

Wind-deflecting: Non-deflecting mast, wind-deflection achieved from roll-up sign.

# Product Specification Sheet



## E-350/380 Series Sign Stand

Description: Eastern **Metal/USA-SIGN E-350** Econo Stand, Tripod Style Sign Stand with a 3 flag holder permanently attached to the mast. (Tested units had three wooden dowel flags in the flag holder.)

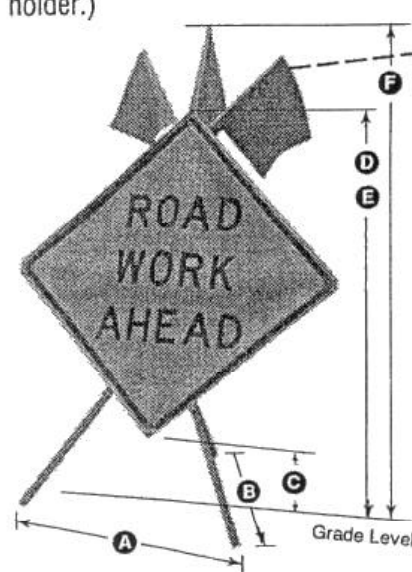

FROV-118/24\* 18" Square fluorescent vinyl flags on 24" x 3/4" wooden staffs.  
Individual Flag Weight: ..... 0.4 lbs

### E-350 with a Reflexite® Endurance™ Sign

#### Material/Construction Features:

Signs: High performance thermoplastic sign with high visibility retro-reflective sheeting. The sign is held on the stand by rigid sign holders permanently mounted to the sign stand, no other hardware is mounted to the sign.

48-EFR\* 48" Endurance Sign, (16 s.f.) Total Weight: 11.0 lbs

36-EFR 36" Endurance Sign, (9 s.f.) Total Weight: 9.2 lbs

#### E-380 Roll-up Sign Material/Construction Features:

Roll-up Signs: All Fabrics, w/ 3/16" or 5/16" thick Horizontal and 3/8" thick Vertical Fiberglass Cross Braces, lexan pockets and washers. With exception of hardware, no other metal parts are used.

48-\* 48" Roll-up Sign, (16 s.f.) Total Weight: 5.55 lbs

36- 36" Roll-up Sign, (9 s.f.) Total Weight: 3.63 lbs

Model Number	Description	Weight	Fully Extended Foot Print		Height Above Grade Level			
			Width <b>A</b>	Depth <b>B</b>	Bottom of Sign <b>C</b>	Top of Mast <b>D</b>	Top of Sign <b>E</b>	Top of Flag <b>F</b>
E-350*	Series Standard Steel Tripod Stand for Rigid Signs	17.5 lbs	48"	47-1/2"	15"	73-1/2"	73"	91"
E-380	(Same) Steel Tripod with additional roll-up sign bracket	18.5 lbs	48"	47-1/2"	15"	73-1/2"	73"	91"

#### Stand Material/Construction Features:

**Stand Tubing:** 16 ga. Cold-formed galvanized 1-1/4", and 1" tubing ASTM-A500 Rated Steel.

**Wind-deflecting:** Non-deflecting mast, wind-deflection achieved from roll-up sign.



# Product Specification Sheet



## B35-12 All-Plastic Type III Barricade

Description:

**Eastern Metal/USA-SIGN Melba 99** Type III Barricade with plastic blades, upright posts, and skid bases.

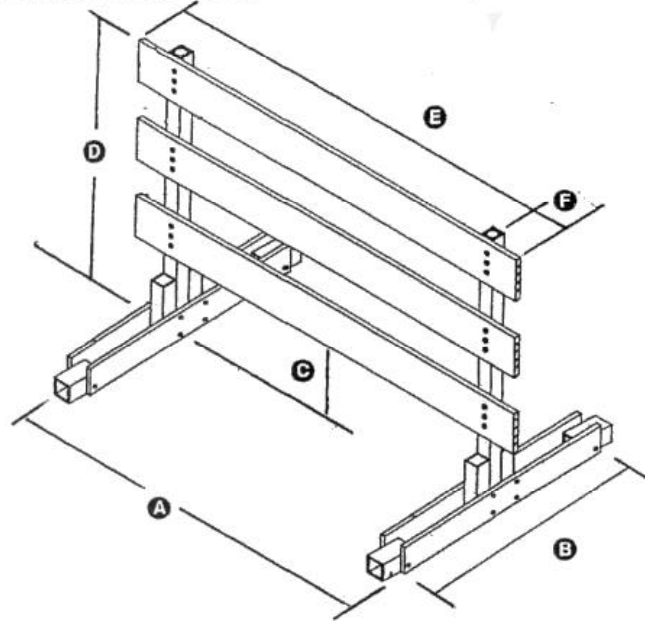

Model Number	Description	Weight	Skid Foot Print		Above Grade Level		Width of Blade	Post to End of Blade
			Width <b>A</b>	Depth <b>B</b>	Bottom of Blade <b>C</b>	Top of Post <b>D</b>		
*B35-12	Type III Barricade - 12' Blade	99.0 lbs	133"	72"	15-1/2"	60"	144"	6-1/2"
B35-10	Type III Barricade - 10' Blade	92.0 lbs	109"	72"	15-1/2"	60"	120"	6-1/2"
B35-8	Type III Barricade - 8' Blade	86.0 lbs	85"	72"	15-1/2"	60"	96"	6-1/2"
B35-6	Type III Barricade - 6' Blade	79.0 lbs	61"	72"	15-1/2"	60"	72"	6-1/2"
B35-4	Type III Barricade - 4' Blade	72.0 lbs	37"	72"	15-1/2"	60"	48"	6-1/2"

### Common Material/Construction Features:

**Barricade Panels:** 1-1/4" thick by 9" wide exterior 100% recycled UV Stable Window PVC. Outer wall shall be 1.5-2.4 mm with inside reinforcement walls of 0.9 - 1.2 mm thick.

**Vertical Support Tubing:** 60" high by 80mm square posts with a 2.6 mm wall thickness (1.0-.09mm), safety orange in color, 100% recycled PVC. Each post is sleeved with a 2.5" (64 mm) diameter schedule 40 PVC pipe, through its entire length.. 2 each, 6" x 80 mm square posts with 2.6 mm wall thickness (1.0-.09mm), safety orange in color, 100% recycled PVC. 6" molded recycled PVC plug inserted in post bottom, used for added stability.

**Skid End Spacers:** 2 each, 6" x 80 mm square sections, 100% recycled PVC.

\* Tested Product

# Product Specification Sheet



## X-600/X-500 Series Sign Stands

Description:

**Eastern Metal/USA-SIGN** 48" Diamond Endurance Sign with 3 wood dowel flags, attached to X-602 Series Wind Deflecting Interstate Series Sign Stand.

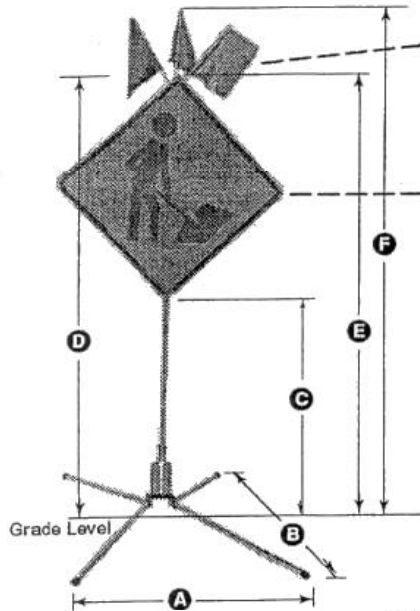

FROV-118/24\* 18" Square fluorescent vinyl flags on 24" x 3/4" wooden staffs.  
Individual Flag Weight: ..... 0.4 lbs

X-602 with a Reflexite® Endurance™ Sign

**Material/Construction Features:**

Signs: High performance thermoplastic sign with high visibility retroreflective sheeting. The sign is held on the stand by two rigid sign holders permanently mounted to the sign stand, no other hardware is mounted to the sign.

48-EFR\* 48" Endurance Sign, (16 s.f.) Total Weight: 11.0 lbs

36-EFR 36" Endurance Sign, (9 s.f.) Total Weight: 9.2 lbs

Model Number	Description	Fully Extended Weight	Height Above Grade Level					
			Foot Print Width <b>A</b>	Foot Print Depth <b>B</b>	Bottom of Sign <b>C</b>	Top of Mast <b>D</b>	Top of Sign <b>E</b>	Top of Flag <b>F</b>
X-602*	Large Interstate Dual Coil Spring Aluminum Sign Stand with two steel Rigid Sign brackets on mast	52 lbs	52"	121.5"	60"	136"	136"	156"
X-502	Mid Size Interstate Dual Coil Spring Aluminum Sign Stand with two steel Rigid Sign brackets on mast	34.0 lbs	36"	81"	12"	96"	96"	116"

**Stand Material/Construction Features:**

**Stand Tubing:** .125" Wall thickness x 1-9/16" and 1-1/4" 6061-T6 Extruded Aluminum

**Spring System:** 2 Vertical heavy coil steel springs mounted to base and mast with bolt/lock washer set threading into custom composite cast "plug" turned into spring.

**Base, Sign Brackets, Flag Holder, Connecting Brackets:** Formed/Fabricated Steel with powder coated, galvanized or anodized finish.

\*Tested Product

# Product Specification Sheet



## X-840 Series Sign Stand

Description: Eastern **Metal/USA-SIGN X-840** Series non-deflecting Interstate Series™ Sign Stand with a 3 flag holder permanently attached to the mast. (Tested units had three wooden dowel flags in the flag holder.)

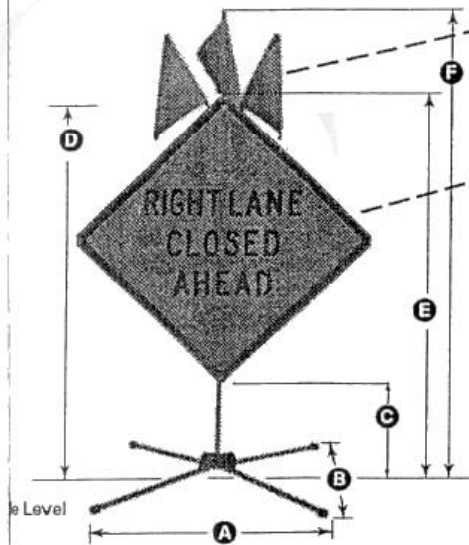

FROV-118/24\* 18" Square fluorescent vinyl flags on 24" x 3/4" wooden staffs.  
Individual Flag Weight: ..... 0.4 lbs

### X-842 with a Reflexite® Endurance™ Sign

#### Material/Construction Features:

Signs: High performance thermoplastic sign with high visibility retro-reflective sheeting. The sign is held on the stand by rigid sign holders permanently mounted to the sign stand, no other hardware is mounted to the sign.

48-EFR\* 48" Endurance Sign, (16 s.f.) Total Weight: 11.0 lbs

36-EFR 36" Endurance Sign, (9 s.f.) Total Weight: 9.2 lbs

### X-841 Roll-up Sign Material/Construction Features:

Roll-up Signs: All Fabrics, w/ 3/16" or 5/16" thick Horizontal and 3/8" thick Vertical Fiberglass Cross Braces, lexan pockets and washers.

With exception of hardware, no other metal parts are used.

48-\* 48" Roll-up Sign, (16 s.f.) Total Weight: 5.55 lbs

36- 36" Roll-up Sign, (9 s.f.) Total Weight: 3.63 lbs

Model Number	Description	Weight	Fully Extended Foot Print		Height Above Grade Level			
			Width <b>A</b>	Depth <b>B</b>	Bottom of Sign <b>C</b>	Top of Mast <b>D</b>	Top of Sign <b>E</b>	Top of Flag <b>F</b>
X-842*	Series Standard Steel Stand with two steel rigid sign brackets on mast	24.0 lbs	66"	79"	15"	91-1/2"	86-1/2"	106"
X-841	Series Standard Steel Stand with one roll-up sign holder on the mast.	22.0 lbs	66"	79"	15"	91-1/2"	86-1/2"	106"

#### Stand Material/Construction Features:

**Stand Tubing:** 16 ga. Cold-formed galvanized 1-1/4", and 1" tubing ASTM-A500 Rated Steel.

**Wind-deflection:** Non-deflecting mast, wind-deflection achieved from roll-up sign.

**Base, Sign Bracket(s), Flag Holder, Connecting Brackets:** Formed/Fabricated Steel with a powder coated, galvanized or anodized finish.

\*Tested Product

Enclosure 2, Summary of Crash Tested Work Zone Traffic Control Devices, Eastern Metal / USA Sign Co., WZ-59

Device	Test	System	Orientation	Legs	Base	Mast	Mounting Height	Height(ex flags)	Flags
E-350 Tripod	EM-19	Endurance	Both	Steel	N/A	Steel	381 mm (15 in)	1867 mm	3 wood
X-552 Stand	EM-20	Endurance	Both	Steel	2 Vertical Springs	Telescoping Steel	457 mm (18 in)	2438 mm	3 wood
Melba Type III Barricade	EM-21	Melba	90 degrees	Melba	Posts slip fit into base legs	N/A	N/A	N/A	None
X-602 Stand	EM-22	Endurance	90 degrees	Aluminum	2 Vertical Springs	Aluminum	1524 mm (60 in)	3454 mm	3 wood
X-842 Stand	EM-22	Endurance		Steel	Rigid formed steel	Telescoping Steel	381 mm (15 in)	2692 mm	3 wood

NOTES to Enclosure 1, Eastern Metal / USA Sign Company. Please refer to the body of the letter and individual drawings for the details of each device.

DEVICE: Stand: X-footprint portable sign stand holding roll-up sign. Tripod: Three legs originating from a point behind the top of the sign.

SIGN: All sign panels were rigid thermoplastic "Endurance" material. 1219mm square in "diamond" orientation

LEGS: Legs are of square tubular steel as detailed in the letter.

MAST: All "stands" have square tubular aluminum or steel supports, sizes vary. Mast extends from the base to the top of the sign panel

HEIGHT: This is the height from the ground to the top of the sign panel.

FLAGS: Material of flagstaff: Wood = 618 mm long, 19 mm diameter wood rod.

Enclosure 3, Summary of Crash Tests for Work Zone Traffic Control Devices, Eastern Metal / USA Sign Co., WZ-59

Device	Test	System	Orientation	Windshield Damage
E-350 Tripod	EM-19	Endurance	Head On	None
			90 Degrees	Scrapes
X-552 Stand	EM-20	Endurance	Head On	Extensive overall cracking and deformation exceeding 2 inches. Driver view impaired.
			90 Degrees	
Melba Type III Barricade	EM-21	Melba	90 Degrees	None
X-602 Stand	EM-22	Endurance	90 degrees	Significant local damage caused by corner of sign but glass remained intact.
X-842 Stand	EM-22	Endurance	90 Degrees	Significant local damage caused by corner of sign but glass remained intact.

Enclosure 2, Summary of Crash Tested Work Zone Traffic Control Devices, Eastern Metal / USA Sign Co., WZ-59

Device	Test	System	Orientation	Legs	Base	Mast	Mounting Height	Height(ex flags)	Flags
E-350 Tripod	EM-19	Endurance	Both	Steel	N/A	Steel	381 mm (15 in)	1867 mm	3 wood
X-552 Stand	EM-20	Endurance	Both	Steel	2 Vertical Springs	Telescoping Steel	457 mm (18 in)	2438 mm	3 wood
Melba Type III Barricade	EM-21	Melba	90 degrees	Melba	Posts slip fit into base legs	N/A	N/A	N/A	None
X-602 Stand	EM-22	Endurance	90 degrees	Aluminum	2 Vertical Springs	Aluminum	1524 mm (60 in)	3454 mm	3 wood
X-842 Stand	EM-22	Endurance		Steel	Rigid formed steel	Telescoping Steel	381 mm (15 in)	2692 mm	3 wood

NOTES to Enclosure 1, Eastern Metal / USA Sign Company. Please refer to the body of the letter and individual drawings for the details of each device.

DEVICE: Stand: X-footprint portable sign stand holding roll-up sign. Tripod: Three legs originating from a point behind the top of the sign.

SIGN: All sign panels were rigid thermoplastic "Endurance" material. 1219mm square in "diamond" orientation

LEGS: Legs are of square tubular steel as detailed in the letter.

MAST: All "stands" have square tubular aluminum or steel supports, sizes vary. Mast extends from the base to the top of the sign panel

HEIGHT: This is the height from the ground to the top of the sign panel.

FLAGS: Material of flagstaff: Wood = 618 mm long, 19 mm diameter wood rod.

Enclosure 3, Summary of Crash Tests for Work Zone Traffic Control Devices, Eastern Metal / USA Sign Co., WZ-59

Device	Test	System	Orientation	Windshield Damage
E-350 Tripod	EM-19	Endurance	Head On	None
			90 Degrees	Scrapes
X-552 Stand	EM-20	Endurance	Head On	Extensive overall cracking and deformation exceeding 2 inches. Driver view impaired.
			90 Degrees	
Melba Type III Barricade	EM-21	Melba	90 Degrees	None
X-602 Stand	EM-22	Endurance	90 degrees	Significant local damage caused by corner of sign but glass remained intact.
X-842 Stand	EM-22	Endurance	90 Degrees	Significant local damage caused by corner of sign but glass remained intact.