

# NASA CONTRACTOR REPORT 177522

## **Human Factors in Aviation: Terminal Control Area Boundary Conflicts**

William P. Monan  
Battelle

Prepared for  
Ames Research Center  
Under Contract NAS2-11934

February 1989



National Aeronautics and  
Space Administration

**Ames Research Center**  
Mountain View, California 94035

This report is a work prepared for the United States by Battelle. In no event shall either the United States or Battelle have any responsibility or liability for any consequences of any use, misuse, inability to use, or reliance upon the information contained herein, nor does either warrant or otherwise represent in any way the accuracy, adequacy, efficacy, or applicability of the contents hereof.

# TABLE OF CONTENTS

<b>ACKNOWLEDGEMENTS</b> .....	i
<b>LIST OF ABBREVIATIONS AND ACRONYMS</b> .....	ii
<b>INTRODUCTION</b> .....	1
<b>CONFLICTS IMMEDIATELY OUTSIDE TCA BOUNDARIES</b> .....	4
<b>Territorial Attitudes</b> .....	6
<b>Role of Traffic Advisories</b> .....	9
<b>TCA INCURSIONS</b> .....	13
<b>Causes of TCA Incursions</b> .....	14
<b>Attitudes Regarding TCA Incursions</b> .....	15
<b>Penetrations Resulting in Conflicts</b> .....	16
<b>TCA ACCESS BY GENERAL AVIATION PILOTS</b> .....	17
<b>Denials of Entry</b> .....	18
<b>Outside-the-TCA Vectoring</b> .....	19
<b>Silent Rejection</b> .....	20
<b>ATC TCA BOUNDARY OPERATING POLICIES</b> .....	21
<b>The Upper Boundary</b> .....	22
<b>The Floor Boundary</b> .....	23
<b>Differing Perceptions of TCA Airspace</b> .....	25
<b>BUFFER ZONES</b> .....	27
<b>SUMMARY AND CONCLUSIONS</b> .....	27

## LIST OF FIGURES

<b>Figure 1.</b>	<b>SHAPE OF TCAs AS POPULARLY PORTRAYED VERSUS THE ACTUAL SHAPE .....</b>	<b>3</b>
<b>Figure 2.</b>	<b>LOCATION AND TYPES OF CONFLICTS IN TCA EXTERNAL BOUNDARY AREAS .....</b>	<b>5</b>
<b>Figure 3.</b>	<b>ISSUANCE OF TRAFFIC ADVISORIES IN CONFLICTS LOCATED OUTSIDE TCA BOUNDARIES .....</b>	<b>10</b>
<b>Figure 4.</b>	<b>CONFLICTS RESULTING FROM TCA PENETRATIONS .....</b>	<b>14</b>

## LIST OF ATTACHMENTS

<b>Attachment A.</b>	<b>ACCESSION NUMBERS OF REPORTS USED IN THIS STUDY .....</b>	<b>A-1</b>
----------------------	--	------------

## ACKNOWLEDGEMENTS

Captain William Monan was the principal investigator and author of this study. Other ASRS staff made significant contributions to this effort. Notably, Mr. Edgar S. Cheaney who is responsible for an insightful analysis of the actual versus perceived physical proportions (aspect ratio) of TCAs, and who, as a general aviation (GA) pilot, contributed a number of insights on GA pilots' perceptions of and reactions to TCA airspace requirements.

# LIST OF ABBREVIATIONS AND ACRONYMS

ABC	Code letters used to avoid identifying a location or navigation facility
ACR	Air carrier
AIM	Airman's Information Manual
ASRS	NASA's Aviation Safety Reporting System
ATC	Air traffic control
FAA	Federal Aviation Administration
F/O	First Officer
GA	General aviation
IFR	Instrument flight rules
ILS	Instrument landing system
MSL	Mean sea level
NASA	National Aeronautics and Space Administration
NMAC	Near midair collision
SID	Standard instrument departure
S/O	Second Officer
STAR	Standard terminal arrival route
TCA	Terminal control area
VFR	Visual flight rules
VOR	Very high frequency omnidirectional range station
XYZ	Code letters used to avoid identifying a location or navigation facility

# HUMAN FACTORS IN AVIATION: TERMINAL CONTROL AREA BOUNDARY CONFLICTS

By

Captain William P. Monan\*

## INTRODUCTION

"After our near miss, the Captain asked the controller if he 'had' the traffic. The reply was 'negative'. The Captain then asked, 'shouldn't he have the traffic on radar?' This reply was, 'no, that aircraft is above the TCA'."

Terminal control areas (TCAs) are familiar operational concepts to the airmen users, both pilots and controllers, of the National Airspace System. Invisible, mere lines and symbols drawn on aviation charts, yet real in dimensions and legally significant, the 23 complex volumes of special use airspace tower from 7000 to 12,500 feet (MSL) above all major airports in the country. By system plan and design, these airspace control rings segregate VFR aircraft not under positive ATC control from all controlled traffic (including all commercial passenger carrying aircraft) during initial climb segments from, or instrument approaches into, the busy primary terminals.

Incident reports submitted to the Aviation Safety Reporting System (ASRS) indicate that the TCA enclosures do indeed screen out much VFR traffic from flight through the terminal areas. However, ASRS reports also offer evidence that, like any other fences, the invisible TCA barriers tend to divert the stream of VFR traffic into close-to-the-boundary flow patterns. The upper control layers deflect the enroute fly-bys upward, downward, and outward, either pushing them to above-the-ceiling altitudes or fanning them into wide circular arcs around and below lower TCA rings.

---

\* Previously regional director of flight operations for an international airline, Captain Monan now serves as an aviation safety research consultant to the Battelle Columbus Division's ASRS Office.

The mid-altitude rings frequently are tailored to peripheral airport locations: the concentric circles often are modified into complex shapes--diagonally sliced or scalloped or notched, or at times, even tunneled with internal passageways--so as to minimize off-route detouring of VFR aircraft climbing or descending alongside the TCA's vertical walls. Down low, the bases of the TCA towers deflect light plane, local field operations outward into areas underneath the marquee-like overhangs of the upper TCA floors.

In popular usage, the shape of the TCA is likened to an upside down wedding cake. This analogy is by now well rooted; it can be seen in both official and unofficial publications as well as in training manuals and syllabi. Figure 1a exemplifies the visual portrayal almost universally used in such publications. This is the mental image many, if not most, airmen have of what a TCA looks like. This image distorts the vertical to horizontal spatial aspect ratio of TCAs. Figure 1b is more accurate. The hypothetical TCA dimensioned here has about thirty square miles of horizontal boundary to every one of vertical boundary. It could be likened to a frisbee or a round serving platter. In any case, consideration of "the boundary situation" at TCAs has to recognize that most of that boundary is horizontal.

Hundreds of individual reports to the ASRS, submitted over a seven-year period, provide, incident by incident, a comprehensive portrayal of the characteristic outside-the-boundary environment. Above, below, and alongside TCA boundaries a mix of aircraft types circulates, differing in operational missions, airmen experience, and behavioral traits. High speed turboprops share this space with helicopters, float planes with TV traffic aircraft, singles with multi-engines, hurrying corporates and air taxis with slow private pilot training or pleasure flights or real estate survey rides--none with need either for communications with, or control from, the ATC facility governing the neighboring TCA.

All air carrier and other IFR traffic transitioning into or from TCA terminal airspace must pass through this layer of see-and-avoid boundary traffic. A TCA controller's call-out of traffic--"numerous VFR aircraft in your area"--appeared frequently in airmen's narrations of their traffic conflicts in TCA perimeter crossings. Perhaps more than anything else, this bit of ATC phraseology serves to epitomize the IFR/VFR traffic mix problems that exist around TCAs.



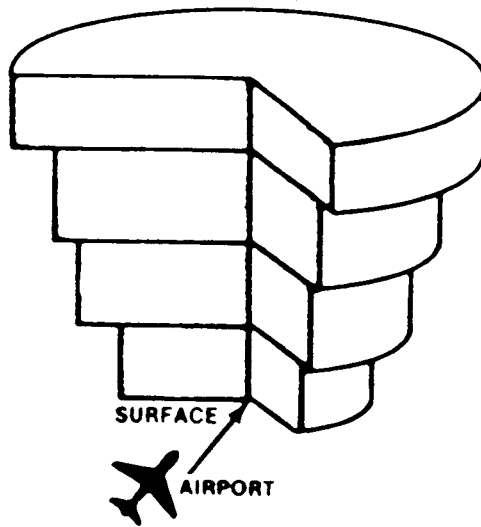

a. A Typical Not-to-Scale Portrayal (From "FAA Aviation News", November-December, 1987)

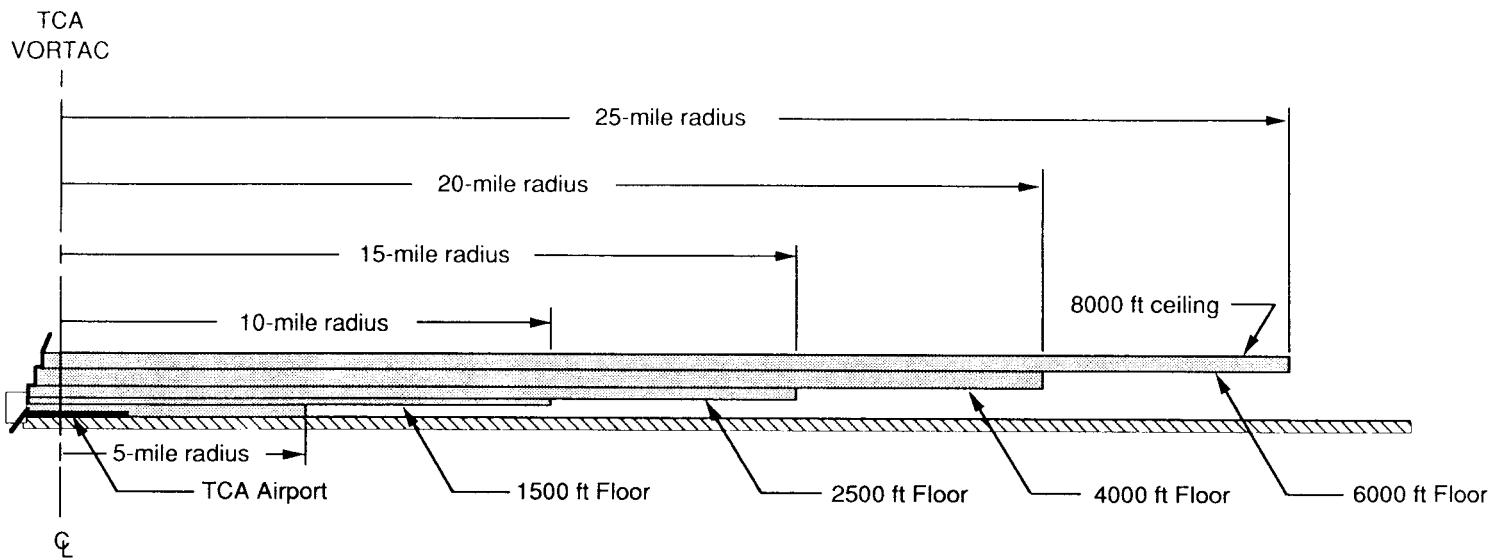

b. True Shape of a Typical TCA as Viewed from the Side (Modeled on San Francisco)

FIGURE 1. SHAPE OF TCAs AS POPULARLY PORTRAYED VERSUS THE ACTUAL SHAPE

Following are the results of our examination and analysis of the seven-year intake of TCA boundary conflict reports received at ASRS between May 1976 and August 1983. All the occurrence reports in the screened study dataset involved conflicts with or among VFR aircraft located in the vicinity of TCA airspace boundaries, either inside or outside, and where "proximity to the TCA" was judged by the reporters or by ASRS analysts to have been a factor in the occurrences. The conflicts studied were those classified in ASRS terminology as either "near midair collisions" (usually conflicts where the reported miss distances were less than 500 feet) or "hazardous conflicts" (threat of actual collision clearly present from context of report but miss distances 500 feet or greater). We excluded conflicts between two IFR aircraft since the TCA and its boundaries are operationally invisible to such aircraft and therefore not a factor in conflicts involving them. It follows from this that all occurrences in the dataset were in nominally acceptable visual meteorological conditions.

During the analysis, the reports were sorted into those describing conflicts outside the TCA boundaries versus those where the conflicts were inside and resulted from unauthorized penetrations. Subsequently, it became apparent that a related and important concern was the difficulty some airmen had experienced in obtaining access to TCA airspace, and the consequences thereof.

### **CONFLICTS IMMEDIATELY OUTSIDE TCA BOUNDARIES**

"After the near miss, the pilot of the light twin came on the frequency. He advised that indeed he was at 8500 feet (500 above the TCA ceiling), he was VFR, he was legal, and he had as much right to that airspace as anyone else."

A total of 381 traffic conflicts adjacent to TCA boundaries were reported to ASRS during the seven-year data period. A conflict was considered adjacent to a TCA if it was within 1000 feet of wall, floor, or ceiling; or if a reporter clearly stated that the presence of a TCA governed or strongly affected decisions and actions. Figure 2 displays the distribution of these occurrences by generic location and types of participants. Two-thirds of the set involved air carriers and these were more or less evenly divided above and

below the TCA. The remaining mix of VFR/VFR and VFR/military conflicts were mostly below the TCA floors. These below-the-floor conflicts tended to cluster near the walls of the next lower rings and thus could also be thought of as lying outside the TCA's lateral boundaries. However, proximity to the floors seemed the more significant factor in most of the cases. In this connection, it is noteworthy that the dataset contained no reports of conflicts located outside the top ring of the TCA and within its altitude band.

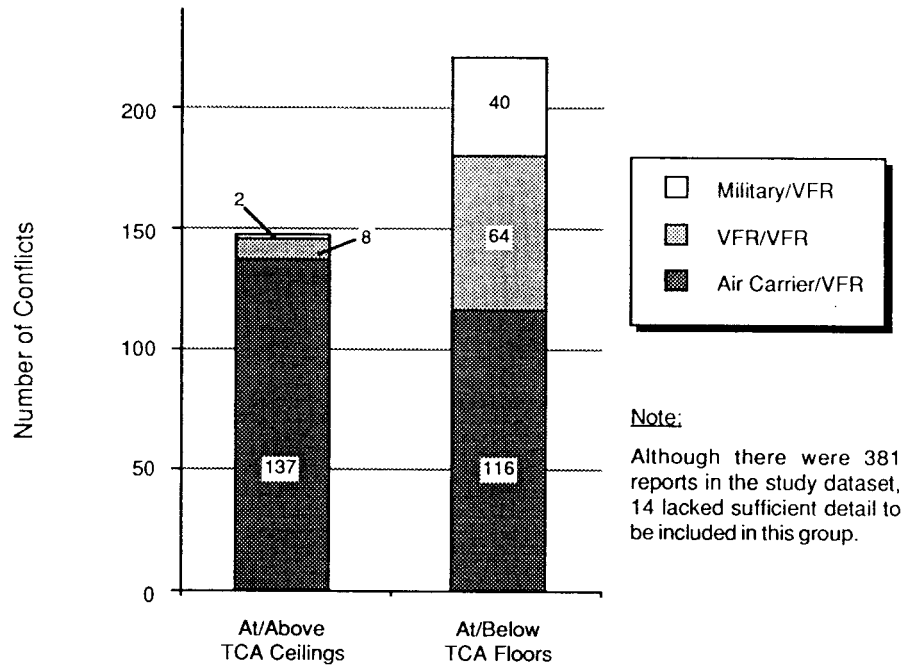

Figure 2. LOCATION AND TYPES OF CONFLICTS IN TCA EXTERNAL BOUNDARY AREAS

The most repetitive and, perhaps, most disturbing element in this 381-report dataset was that in virtually all instances, everyone was legal. No matter who the participants--ATC controller, transport flight crew, military, corporate or general aviation pilot--all were in the right with respect to the applicable FARs and operational manuals. Recognizing the no-fault, no-blame circumstances, reporter protests about the conflicts were perforce limited to "Hey, this is dangerous" types of reactions.

The issue of legality frequently surfaced in the report narratives. The right to occupy boundary airspace seemed a sensitive matter, swiftly and emphatically declared by VFR airmen, and reluctantly accepted by IFR participants in the conflict occurrences:

"The other aircraft was reported at 9500 feet, above the 7000 foot TCA ceiling, so that it appeared that everyone was legal."

"On the localizer, we almost collided with a small aircraft--a 50 to 75 foot miss. He was VFR, operating outside the TCA, so he could go anywhere and do anything he pleased...."

"From this incident, I learned that a midair can happen and yet, everyone could be legal in all respects."

### **Territorial Attitudes**

Legality notwithstanding, many of the objective narrations of near collision occurrences continued into "but..." "nevertheless..." and "however..." subjective statements of disapproval and censure. Charges of "poor judgement", "lack of good sense", and "he ought to know better" personal assessments frequently were levied--criticisms that applied to some airman's intrusion into boundary altitudes or locations normally occupied by other categories of airspace users. "So, he was legal", summed up one airman, "legal but almost dead." "This type of activity should stay away from this area", commented another reporter. "I don't believe a non-transponder aircraft belongs anywhere near where we operate", remarked a third pilot. These and many similar "don't belong here" observations implied and, at times, boldly staked out, informal but definitive claims of territorial imperatives to specific operational sectors in the TCA perimeter layers:

"Over a VOR is not a good place to practice acrobatics!"

"He appeared to be centered directly over the ABC VOR. A perfectly legal but very unsafe location."

"Practicing chandelles at the edge of the TCA is not a very smart idea."

Air Carrier Territory. - User concepts about due ownership of the boundary airspace conformed with operational practice. Air carrier flight crew reporters often seemed to regard the levels above TCA ceiling altitudes as "their territory". Their reports reflected

perplexity and chagrin at VFR pilot selections of altitudes and courses that cut through STAR or SID corridors. "For the life of me", puzzled one such airman, "I do not understand why any VFR pilot would want to fly anywhere near air carrier routings." This comment highlights a large gap in understanding between the IFR and VFR pilot communities. Apparently this air carrier pilot reporter is not aware that nowhere in the VFR charts, manuals, and documents that private pilots are trained to use are air carrier routings in terminal areas usefully depicted.

Our review of the conflict locations narrowed the "anywhere near" to more specific locations on individual terminal area charts. In the descent phases, the critical IFR/VFR flight path intersections clustered at the outer rims of the upper TCA ceiling layers, here narrow, chute-like arrival routes angle downward into ILS feeder fixes even as VFR traffic skirts the TCA in the same vicinity. At those terminals with 7000 or 8000 foot ceiling heights, the altitudes to avoid ranged from 7000 to 10,000 feet in the descent corridors.

The "hot spots" for IFR/VFR confrontations were less well defined in the SID departure routings; conflict patterns were more erratic; and fewer SID procedures were identified by name in the narratives. Altitudes of these boundary conflicts sometimes were low--airliners at times emerged through the sides of the TCA enclosures if held down within the TCA. Overall, the climbout corridors apparently tended to carry air carriers away from the main stream of over-the-top VFR traffic flow.

There was one major challenge to the air carrier flight crew concept that the tier of altitudes above TCA ceilings "belonged" to IFR aircraft. The airspace directly overhead the terminal complex was heavily utilized by the more sophisticated segments of the VFR community--the air taxis, short haul commuters and private pilot cross country missions. These high time, more experienced VFR operators demonstrated sharp, pragmatic know-how regarding ATC system workings. Their over-the-top, direct routings anticipated that air carriers normally would not enter or exit TCA ceilings directly overhead the runway complex. However, at certain terminals, use of preferential runways requires a 180 degree reversal of course after takeoff: heavily loaded air carriers are programmed via these SID procedures to emerge through the TCA roof directly above the airport layout, so this presumption is not always correct.

GA Territory. - While the IFR airspace users protested the VFR incursions through arrival/departure corridors, general aviation pilots staked out claims to the lower altitudes beneath the TCA floors. Their attitudes were consistent and firm: air carriers "did not belong" in local VFR training areas. The reporters--frequently low time students or flight instructors--expressed dismay at sighting airline jets thundering through "their" space. "There is no excuse for this", complained one private pilot. "At their speed, there is little time to get out of their way"; "I rolled out of a turn and found myself head to head with an air carrier"; "We stay out of their airspace", snapped a light plane instructor, "they should stay out of ours!"

Additional assertions that the boundary areas below the upper TCA floors "belong" to VFR airmen were evident in corporate pilot submissions. ATC classification of their activities as "general aviation" apparently denies them access to high altitude entry and exit transitions at some major TCA terminals. Such reporters "wanted out" from their usual low altitude passages through the sides of TCAs. "We have to zigzag our way through congested layers of low level VFR activities", stated an executive pilot. Another report read, "Most of us can out-climb, out-cruise, and out-perform almost any type of air carrier. So, we should be handled in the same way they are."

This same theme was present in reports by several airmen operating turboprop equipment for the new generation of air carriers serving many of the short haul, intercity markets. Their reported experiences suggest that airspeed differentials can and do lead to overtake conflicts in the TCA boundary mix. "Our climb speed is 170 knots", stated one airman, "We do not belong in altitudes and areas with aircraft flying at 70 or 80 knots." Similarly, regional air carrier pilots abjured any rights to the low altitude below-TCA-floor areas while laying claim to higher strata. Summarized one commuter captain, "I've had too many near collisions with VFR (boundary) traffic. Air carrier jets are required to stay above the TCA floors. Our turboprops belong there too."

Inevitably, a number of airmen reporters of TCA boundary conflicts progressed to what appeared to them a self-evident conclusion. If all participants in a near midair collision were legal and without blame, then something must be wrong with the ATC system. "Simply stating that VFR aircraft are responsible for their traffic is ignoring that a problem exists." "The controllers at this facility all believe that the IFR/VFR mix (at

our TCA boundaries) tests the see-and-avoid concept to its limits." "I believe the system is at fault", and finally, "There has got to be a better way than this!" The reporters' phraseology varied, but the ultimate assessments of system deficiency were unequivocal.

Many of the "something is wrong with the system" deductions were associated with the absence of radar traffic advisories prior to the conflict occurrences.

### **Role of Traffic Advisories**

"We screamed at Departure for not advising us of the traffic....They said they had no traffic on their scope."

As noted previously, this dataset contains 381 reports of conflicts in boundary areas adjacent to TCAs, many of them described as narrowly avoided collisions. One hundred thirty-seven (137) of these air carrier encounters with VFR aircraft took place in above-TCA ceiling altitudes. In 100, ATC provided no radar callouts of traffic prior to pilot conflict detections. In areas below TCAs, 116 air carrier/small aircraft conflicts were reported; in 73 of these there were no prior advisories of nearby traffic. Thus, in the dataset of 253 above-or-below conflicts, 173 appeared to be strictly see-and-avoid affairs, without traffic advisories from ATC.

The conflict incident data submitted by VFR airmen and military pilots yielded comparable statistics. Fifty-six of the 72 VFR/VFR single or twin engine incidents indicated that no prior controller advisories of traffic had been issued, and the same was true of 28 of the 42 military/VFR conflicts.

Figure 3 summarizes the conflict dataset with regard to issuance of ATC radar advisory callouts.

The majority of air carrier pilot reports in this set of conflict events labelled the VFR aircraft as "unknown and not using a transponder." The see-and-avoid convergencies elicited sharp "What's going on?" types of queries to the controllers. "Why wasn't the traffic called?" "Why wasn't the aircraft observed on radar?" "Why did the system permit non-transponder, uncontrolled aircraft to operate in the congested terminal areas?"

Such were typical questions in the cockpit-controller dialogue subsequent to the near collision events.

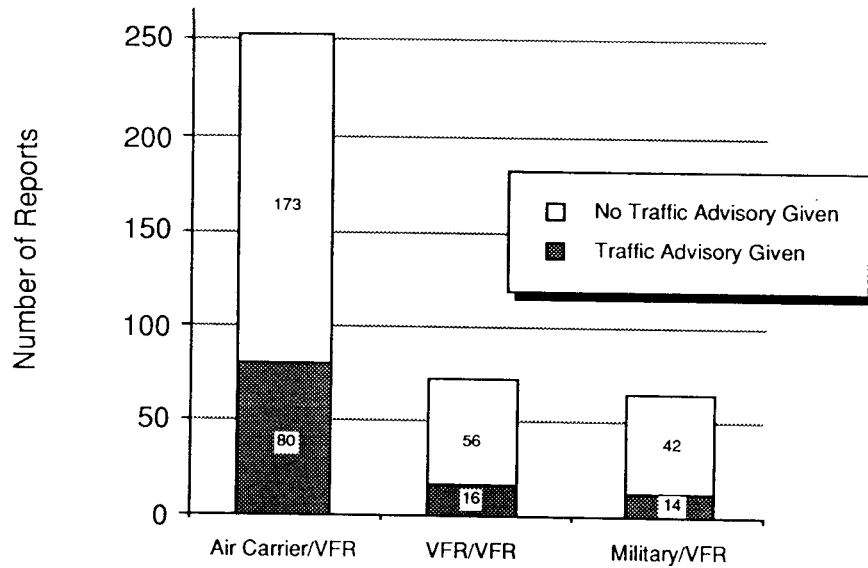

Figure 3. ISSUANCE OF TRAFFIC ADVISORIES IN CONFLICTS LOCATED OUTSIDE TCA BOUNDARIES

Indeed, the AIM emphasizes ATC's limited radar coverage of VFR aircraft which are not transponder equipped or whose transponders are not activated:

"It is very important for the aviation community to recognize the fact that there are limitations to radar service and that ATC controllers may not always be able to issue traffic advisories concerning aircraft which are not under ATC control and cannot be seen on radar. ...the amount of reflective surface of an aircraft will determine the size of the radar return. Therefore, a small aircraft...will be more difficult to see on radar than a large commercial jet..."

The Critical Need for Traffic Advisories. - The hazard level in these non-targeted conflicts appeared high. The unexpected sightings of the converging aircraft frequently were late, at times too late for evasive maneuvers. Forty-five reports indicated that the two aircraft passed with neither controller intervention nor pilot evasive actions. Evasive actions, when taken, were hard, quick responses: "I sounded out and pushed the yoke



forward"; "The S/O shouted, 'watch out!' My eyebrow window was completely filled with the underside of a light colored twin"; "The first officer said, 'Oh, my!' and pointed"; "The F/O made an exclamation. I looked up to see a twin engine plane bearing down on us"; "Our window was full of his belly and right engine".

The smaller number of reports submitted by the VFR conflict participants exhibited similar elements of surprise and alarm. Passenger yells of "Watch out!", "I looked up to see...", and rushed maneuvers "to get the hell out of the way" colored the narrative. Several general aviation airmen registered strenuous protests at air carrier failures to maintain traffic vigilance in a see-and-avoid environment.

"The air carrier flight crew must have had their heads 'down and locked'. All they had to do was to look out their windows to see me. My aircraft must have filled their entire windshield."

Why Advisories Were Not Given. - Pilots often demanded to know why advisories had not been issued and quoted controller responses: "Asked departure if he had the light twin, radar said, 'No'." "The controller replied 'Negative'." "The controller said that he did not have him on radar. Why, I do not know." "Such failures to paint non-transponder equipped aircraft creates a widespread belief that despite all the regulations, the ATC system is operating in an atmosphere of blind luck!"

Scores of ATC controller reports confirmed that the "unknowns" were not painting targets on their scopes. "The air carrier pilot asked if I had traffic...I informed him that I observed no primary or secondary targets in his vicinity. He then said he wanted to file a near miss report."

Scattered through the data were controller mentions of facility radar limitations. Factors associated with the non-sighting of VFR aircraft include no transponder squawk from the aircraft, target overlaps, aircraft passing through the "main bang" (antenna site), and specific geographic areas of known poor radar coverage due to antenna locations and the inherent limitations of radar.

Numerous reports noted a controller's belated observation of a "faint, primary target" immediately subsequent to a pilot's calling of a near miss with untargeted traffic. Fre-

quently tinged with dismay, airmen repeatedly quoted near identical communications with the TCA controllers: "The controller first replied, 'Negative', and then added, 'Oh, now I see him'." "The controller said, 'No radar contact', then added, 'Yeah, now I see him, six o'clock and 2 miles'." "When queried, approach advised they had a 'faint, primary target behind us'."

A subset of the after-the-conflict radar observations of traffic included an additional element: the sudden blossoming of a 1200 squawk behind the air carriers' Mode C return. "A transponder appeared immediately after the NMAC...." "The controller said he had nothing in the area and then he said, 'Just now a VFR 1200 code started squawking behind me'." "A 1200 squawk appeared right after the near midair...." "We pushed down, passed underneath him. 'No traffic', said the controller. Moments later, the controller reported a transponder return, a target westbound at 7200 feet...." A controller's viewpoint: "The pilot must have had the life scared out of him and was reminded that his transponder was not turned on."

The least satisfactory responses to airmen's queries regarding uncalled traffic were statements that uncontrolled VFR aircraft operating outside the TCA airspace dimensions were outside controller jurisdiction and responsibility:

"We enquired from departure as to who the other traffic was that we almost hit. The reply was that he did not have to point out VFR traffic that was outside the TCA."

"We evaded....When the captain asked the controller why they had not pointed out traffic, his reply was, 'We don't have time to point out all the traffic'."

"No traffic was issued to the air taxi because...[he] was outside and below the floor of the TCA."

"I asked departure about it...the controller said he was at 7500 feet and not in the TCA, since top of the TCA was 7000....Nevertheless, a dead-on target should be called out!"

Two flight crew reports related an "I don't believe what I'm hearing" response to controllers' seemingly complacent acceptance of near collisions:

"After we passed underneath the other aircraft, we told approach that we had just missed a guy, whereupon the controller gave us a standard 'Roger' response!"

"We advised approach that we had just had a near midair. The controller answered, 'Roger, your near midair. Numerous targets your vicinity'."

Thus the causal structure of the reported outside-the-boundary conflicts seems dominated by two factors: the absence of ATC advisory services alluded to above, and the subjective territorial attitudes of the participants discussed previously. The one characteristic this set of incidents had in common was that all participants were legal and performing in accord with formal aviation system requirements. Thus it appeared to the majority of these reporters that outside-the-boundary conflicts are an outgrowth of basic system design. Inside-the-boundary conflicts--and the airspace incursions that spawn them--present a different picture which we describe in the next section.

## TCA INCURSIONS

"I thought I was at least 7 miles south of the TCA when the approach controller advised me that I was over the XYZ outer marker..."

A total of 213 reports of TCA incursions were submitted to the ASRS during the seven-year period covered by the dataset used in this study. Broad categorical comments by controller reporters indicate many other similar transgressions were neither reported to the ASRS nor to the FAA. "TCA violations are common at this facility..." noted such a report. "There are frequent penetrations of our TCA at this facility", stated another controller. One apparently exasperated controller wrote, "Three times this same aircraft has violated our TCA. Today, I managed to track him to ABC field; then my supervisor told me to forget it!"

Figure 4 illustrates who committed the unauthorized TCA penetrations and describes the conflict outcomes. VFR pilots, the most frequent violators, submitted almost the same number of reports as air carrier pilots, who mostly observed TCA violations. Quite dif-

ferent motivations for reporting are implicit in the data, however. All the air carrier pilot reports referenced resultant conflicts. There was a clear note of ire in the narratives; they felt victimized by the combination of airspace penetrations and (usually) the absence of timely advisories of such penetrations from ATC. Conversely, only six of the VFR reporters described conflicts resulting from their actions. Many indicated that they were facing possible enforcement actions.

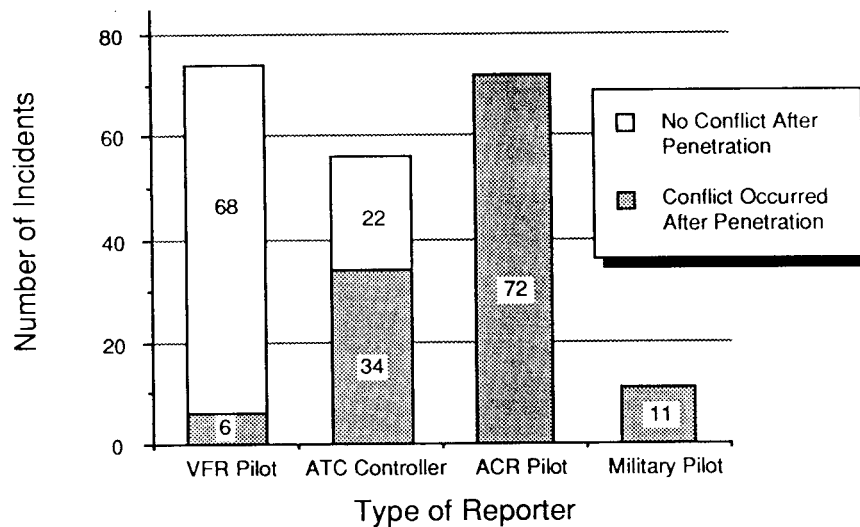

Figure 4. CONFLICTS RESULTING FROM TCA PENETRATIONS

### Causes of TCA Incursions

While controllers can observe "unknowns" straying through their airspace boundaries, they seldom know why these penetrations take place. However, 68 of the 74 pilot reporters provided four basic categories of explanation for their errant actions. Further, a theme running through all these reports is limited experience, or lack of knowledge, in coping with TCA operations.

The first explanation was the ordinary "goof": "It was such a beautiful day and I was enjoying the countryside immensely. Unfortunately...." "I got so distracted flying the airplane that I did not realize...." "I forgot about the TCA completely...." "I got confused...." "I should have watched my heading more closely...." One pilot revealing a far

less professional attitude complained, "No one told me the floor of the TCA was 1800 feet."

A second set of reports referenced unfamiliarity. "It was my inability to find landmarks in an unfamiliar area." "I mistook bridge A for bridge B." "I misidentified two similar looking freeway intersections...." "The Everglades gave me no positive landmarks...." "There were no landmarks in the lake." These explanations often were preceded by, "I realize that unfamiliarity is no excuse but...."

A third group of general aviation reports blamed illegal entries upon inadequacies or deficiencies in the TCA charts. "Nowhere on the chart did it say 'smokestack' as a landmark reference...." "I find this particular chart very difficult to read", and, finally, "that blankety-blank chart!" Several other pilots admitted to having been "caught out" without TCA charts on board.

The fourth and final category of explanations related to communications: some individuals assumed that being in two-way radio contact with ATC carried an automatic authorization for TCA entry. One airman's view: "No one told me to stay out of the TCA." On some occasions, VFR pilots opted to "push ahead" rather than wait out clogged radio frequencies. An air taxi pilot justified his entry with, "I'm flying a gas guzzling twin on a schedule...what am I supposed to do?" "This is a common problem", admitted one controller. "You are so busy that many aircraft can't get radio contact right away and so [they] violate the TCA."

### **Attitudes Regarding TCA Incursions**

Controllers. - ATC controller assessments of the seriousness of such penetrations split sharply from the VFR airmen's opinions. They fumed at too-frequent violations: "Many pilots don't seem to know or care about TCAs!" A number of controllers blamed inadequate ground school instruction for the pilot errors. More cynical attitudes targeted "...Kitty Hawk philosophies\*": Why bother with having TCAs if everyone ignores them?"

---

\* A Kitty Hawk philosophy is an apparent presumption that you are flying the only airplane that exists.

GA Pilots. - General aviation pilots focused upon what they perceived as the relative innocuousness of their mistakes. "If I was in the TCA, it was only by a little bit." "I only cut a little corner of the TCA." "The airliner only had to make a slight turn to avoid me."

A few submissions reflected a cut-off-your-own-nose reaction: "Mode C was turned off so as not to further advertise our transgression in the event it had not yet been observed", and, "If ATC follows this up with a violation, then in the future, I simply will not use Mode C in the vicinity of TCAs since this is the only way the FAA has of detecting such violations." However, such escapism was rare. The majority of airmen candidly admitted blame, concluding their narratives with such phrases as "I'll be more careful next time", "I'll prepare better in the future" and similar expressions of personal growth through their experiences.

Several airmen strenuously argued that they had not penetrated TCA boundaries. They insisted that they had turned, or descended, just prior to entry and that ATC allegations of TCA incursions were wrong.

Finally, it is noteworthy that 45 of the 68 non-conflict penetration reports submitted by light plane pilots indicated that these pilots were flying out of peripheral fields located below or near the TCA boundaries.

### **Penetrations Resulting in Conflicts**

One hundred twenty-three unauthorized intrusions by "unknowns" culminated in traffic conflicts with IFR aircraft. Fifty of these IFR/VFR conflict participants received prior callouts of traffic from TCA controllers, but late sighting of the small aircraft led to close encounters. In the remainder of cases, the air carrier/uncontrolled VFR aircraft convergencies were completely unexpected occurrences with no radar targeting of the non-transponder equipped intruders.

Only six of this set of within-the-TCA conflicts were reported by the VFR participants, so we know little of the "why" or the "how" of their penetrations. The aircraft entered and exited the TCAs as unknowns. However, there is no reason to believe that

the explanations for their errors would differ appreciably from explanations to TCA incursions which did not result in conflicts. Undoubtedly, some of these incursions were intentional, but we have no hard evidence of this fact, nor did any of the reporters admit to advertent penetrations of TCAs.

Following is a sampling of narratives relating to non-targeted IFR/VFR conflicts subsequent to a TCA intrusion. The near collisions stirred air carrier flight crew reactions best typified by this comment: "Please! No more surprises!"

"While descending through 5800 feet, a small single engine aircraft was observed at 1 to 2 o'clock. He was in an evasive maneuver and passed approximately 200 feet above our aircraft."

"This could have been disastrous...Approach radar said they had no transponder display, did not show any aircraft in our vicinity, and commented that the aircraft was violating the TCA."

"On approach to 09R, on glide slope, at 2500 feet, observed small aircraft crossing from 10 o'clock approximately 50 feet below our altitude. No time to take evasive action."

"Since floor of the TCA is 1900 feet here, appears that other aircraft was violating TCA."

In summary, every TCA incursion risks a conflict, and when conflicts do result, IFR flight crews are frequently "caught napping", and have little opportunity to take considered avoidance action. In this dataset, most of the incursions resulted from blunders of one kind or another associated with inadequate planning, navigation errors, or communications breakdowns. A small minority may have been intentional. Some of the incursions, as well as the previously discussed outside-the-boundary conflicts were caused in part by difficulties experienced by VFR pilots in gaining access to TCA airspace. This topic--vigorously discussed in many VFR pilots' submissions--merits further examination.

## **TCA ACCESS BY GENERAL AVIATION PILOTS**

"As usual, refused entry into the TCA. As usual, vectored the hell out of everybody's way but not toward my destination..."

As air carrier flight crews counted off perceived ATC system deficiencies and TCA controllers called for cessation of the too-frequent penetrations of the restricted terminal areas, general aviation pilots protested minimum or nonexistent ATC services associated with VFR passage through or around TCAs.

Many general aviation airmen reports depict attempts to obtain TCA clearances as frustrating, exasperating incidents, never to be repeated. Not only were the light plane reporters frequently denied enroute transits through the terminal areas, but they were then vectored many miles off their direct routes to their destinations. At times, their entries were approved only after holding periods in the crowded boundary areas. Requests for radar advisory services while circumnavigating the TCA enclosures frequently received short-shrifted rejections.

### **Denials of Entry**

The narrative tones of airmen's protests ranged from simple, "I don't understand it" comments to strongly phrased objections alleging unfair treatment. "TCA controllers give us [GA pilots] a hard time. Apparently they can't stand the thought of VFR planes going through their airspace." "When I contact the TCA controller for entry, he is always 'too busy' to let me through the TCA." "Unable", "too many aircraft", "I don't have time for you": such were the quoted controller phrases that preceded the "remain clear of the TCA" instructions. Similar comments referenced ATC refusals to provide VFR traffic advisories: "After I identified, the controller said he was too busy for any VFR advisories"; "Approach informed me that he would not provide me with advisory service"; "The controller replied, 'Unable; you are on your own; so long'." Denials of ATC services stung reporters into finger-pointing charges of discrimination: "It appears to me that ATC is unfair to private pilots"; "We are not treated equally!"; "ATC is unresponsive"; and "The TCA controllers at this facility keep insisting that their concerns for air carrier safety are paramount."

Ironically, numerous light plane airmen, denied TCA entry, displayed concern at being forced to fly through the VFR-congested boundary areas encircling TCA airspaces. "There was no reason for the controller to abandon me in a potentially unsafe, heavily



saturated traffic environment!" reported one private pilot. Similar concern for their own safety led two reporters to question a controller's motivations:

"The controller apparently felt that if a collision occurred, it would take place outside the TCA and so, outside his jurisdiction."

"We were denied TCA entry....this increased the risk of a midair due to the numbers of light aircraft in the area. Since my conflicting traffic would be VFR and below the TCA, the controller's responsibility for a midair would therefore be minimized."

VFR pilots may not fully appreciate ATC guidelines regarding VFR passage through TCA airspace. Controller workload priorities are spelled out on every TCA area chart: VFR transits through the TCA are authorized "when traffic conditions permit". Similar conditional approvals apply to requests VFR pilot requests for traffic advisories. All 23 TCA charts carry notations that such additional services will be offered "on a workload permitting basis".

### **Outside-the-TCA Vectoring**

Another set of general aviation reporters asserted that off-course vectoring during circumnavigation of terminal areas constitutes unwarranted ATC control over VFR activities. "I was below the TCA", narrated one private pilot, "so, I should have been able to proceed on my course direct to my destination." Another: "Since I was outside the TCA airspace, I saw no reason why I should be issued so many changes in heading." And, a controller reports: "The small plane pilot was not happy with being vectored some 40 miles out of his way....He made remarks and finally stopped responding to any of my instructions."

Pilots of light aircraft who had filed IFR flight plans, and who intended to cross over TCAs, sometimes fared no better than the VFR reporters. Upon changeover to TCA approach frequency, their over-the-top planned flight tracks were amended to circuitous routings that reportedly added as much as 60 miles to their planned flight.

Such experiences spawned "never again" types of pilot reactions. No more zigzag courses around the TCA airspace blocks, no more "umpteen" changes in frequencies,

headings and/or altitudes. The planned alternatives consisted of "off with the transponder", "no call-ins to ATC", and go it on their own via over-the-top direct tracks toward their destinations.

"In the future, I will avoid all radar services, vectorings, and advisories and fly under the TCA with no radio communications and no transponder rather than be harassed this way."

"On my last 3 flights, I cancelled IFR, flew over the TCA and refiled again after I transited the area."

"In the past, the TCA controller is always 'too busy' to let me through the TCA. Worse, I am then issued a complicated set of directions taking me completely around the TCA, tripling my flight distance and running me through high density traffic around the TCA....So, now I go VFR and fly over the top of the TCA."

"It's simply too much trouble", summarized one such VFR pilot reporter, "They delay you, vector you, and if you happen to be coming down in the area you might be caught in...holding...Why bother?"

### **Silent Rejection**

A number of general aviation reporters indicated that ATC's "not welcome in the TCA" attitudes toward VFR aircraft, may, at times, extend into "Don't bother me" modes of silent, brush-off treatment. Some of these reporters expressed puzzlement as to why their repeated initial call-ins and/or requests for advisory services were not answered. In some narratives, radio equipment problems were theorized as possible explanations. Other airmen presumed that controllers were busy and continued their calls, with wonderment that "there were only two or three aircraft on the frequency" or "there did not seem to be much radio traffic".

However, a subset of these reporters discerned an apparent relationship between the controller's belated acknowledgment of their calls and their departure from the terminal area. "Only after repeated calls did the controller answer me. He informed me that I was leaving his area." At times, the reports noted that a message content of "leaving the area" with "a frequency change" comprised both the initial acknowledgment and sign-off. Some

pilots were bluntly accusatory:

"This is a statement that XYZ approach ignores VFR traffic moving along the shoreline. Many of us have the feeling that XYZ controllers are either ignoring or pretending not to hear our requests for advisories until our aircraft are beyond their area. Then, they hear you and advise you that you are out of their area."

The preceding citations leave little doubt that there exists a segment of the VFR flying community which believes that its members are treated as "second-class citizens" in TCA and near-TCA environments, and this they strongly resent. The extent of such attitudes is not known, but their potential for undermining safety is obvious and should be taken into account by those who design and operate the aviation system.

### ATC TCA BOUNDARY OPERATING POLICIES

"After our near miss, the controller advised that many light aircraft flew in the area just below the TCA."

There are no buffer areas around TCA airspace. By legal definition, one foot of altitude above a TCA ceiling or below a TCA floor places an aircraft outside TCA boundaries. Identical horizontal tolerances apply to aircrafts' lateral separation from TCA walls.

As practical flight parameters, such margins are meaningless. It can be argued that TCA boundaries should be treated as maximum "never exceed" limits, red-lined areas of operation not to be approached too closely by either VFR or IFR aircraft.

The AIM's coverage of collision hazards at TCA boundaries conveys a similar, "stay-away-from-trouble" message. "VFR aircraft are cautioned against operating too closely to TCA boundaries...."\* Yet, many of the conflict reports in the study dataset

---

\* U.S. Department of Transportation, Federal Aviation Administration, Airman's Information Manual, November, 1987, Section 3, paragraph 97b(a)(d).

indicate that numerous VFR airmen choose to operate on or very close to TCA boundaries.

### **The Upper Boundary**

Air carrier pilots reported the majority of near miss events in the above-the-TCA environment. They cited conflicting traffic at or within a few hundred feet of ceiling altitudes. "The incident occurred at 8000 feet, the exact ceiling of the TCA." "Upon advising ATC of our near miss (at 7100 feet), we were told, 'TCA ceiling in that area is 7000 feet'." "We were passing 7000 feet (TCA ceiling) when we saw the aircraft. We pushed down beneath him." Etc.

In many reports, the circumstances precluded an exact determination of the altitudes of conflicting uncontrolled traffic. Abrupt, come-and-gone sightings of the converging aircraft, and frequently, hard evasive changes in body angle and climb or descent rates tended to blur perception of conflict altitudes. "All that really registered was that this object was filling my windshield." "It was a traumatic two or three second period."

Air Carrier Pilot Knowledge of TCAs. - Air carrier pilots often asked controllers whether conflicting traffic had been in or out of the TCA, a question which implicitly revealed their uncertainty regarding TCA dimensions. These airmen tended to quote or paraphrase controllers' statements as confirmation of the TCA ceiling heights. "The controller then said the TCA ceiling was 7000." "I asked departure...the controller said the traffic was at 7500 feet and then added that the TCA ceiling was 7000 foot tops." "We were informed that the TCA ceiling was 7000." These numerous "controller said" inclusions suggest that the air carrier flight crews often have not acquired working knowledge of TCA shapes and dimensions although the information is available to them and, as certificated pilots, they have a duty to be conversant with all aspects of the airspace in which they operate.

GA Pilot Knowledge of TCAs. - On the other hand, the general aviation pilots who submitted reports of their above-the-TCA-ceiling conflicts displayed certain knowledge of their cruise altitudes and the height of the TCA airspace beneath them. They knew they

were in a see-and-avoid environment and frequently expressed indignation that air carrier pilots "obviously were not participating in the see-and-avoid system". One shaken pilot, overflying a TCA at a legal 7500 foot altitude, presented the VFR airman viewpoint: "Only by the grace of God did I see this airliner climbing head-on straight at me...they just popped out of the TCA and if they had only looked out their window my aircraft would have filled up their entire field of vision!"

### **The Floor Boundary**

The AIM's injunction against operating too closely to TCA boundaries continues into a more specific warning: "...especially where normal cruise altitudes are at or near the floor of higher levels [of the TCA], observance of this precaution will reduce the potential for encountering a TCA aircraft at floor altitudes."\* Air carrier jet departures seldom are held down to TCA floor altitudes. However, at almost all major airports, arrivals are routinely stairstepped down during initial approach from one floor level to the next, working their way through the complete tier of TCA rings. It is this inbound procession of air carriers, often on vector headings while maintaining floor altitudes, that appears most vulnerable to conflicts with light planes skimming beneath the TCA shelves.

Controller Viewpoints on Hazards at the Floors. - Controller reports sometimes addressed these hazards in a general manner:

"A procedure is in use at XYZ that I feel has potential for a serious accident. Inbound IFRs are routinely assigned altitudes at the floor of the TCA (4500 feet) since this is a normal VFR cruise altitude."

"Our normal procedure is to descend arrivals to the floor of the TCA (3000 feet). TCA violators are common in this area and separation frequently becomes lost between these arrivals and aircraft operating from XYZ field located beneath the approach path to the runway."

The problems these controllers observe are not unique to these facilities. Controllers at other locations verified the hazards of flying too closely to floor altitudes with air carriers crossing directly above the VFR aircraft. "This area is recognized as one of

---

\* Ibid.

potential conflict. VFR pilots can maintain 2500 feet, stay below the TCA and become traffic." "The dimensions of our TCA allow VFR aircraft to operate just below the localizer course outside the outer markers. Today, a light twin, unidentified, crossed in front." Thirteen conflicts were reported at one major terminal between air carriers on final ILS approach and small planes crossing through the localizer courses. "If either aircraft strays slightly", noted a controller, "then an unsafe situation becomes dangerous."

Air Carrier Pilot Perceptions. - From an air carrier perspective, the most unacceptable variety of close-to-TCA-floor conflicts are those which occur after they have intercepted the localizer and are on the glide slope. Such conflicts produced comments of dismay and non-comprehension of a traffic control system that permitted uncontrolled traffic through the approach lanes. "How can it be legal", asked one airman, "for a pilot to be flying through this area at 1499 feet with no ATC communications, when the TCA floor is 1500 feet?" "I suggest my life is on the line", protested another crew member, "when it is legally possible for VFR aircraft to pass so closely to the approach path of IFR aircraft!" "There seems to be something wrong with the system", concluded another report, "to permit this to happen." "After our near miss on the localizer, the controller said that the other aircraft was below the TCA and there was nothing they could do about the situation."

The same minimal vertical separation intervals noted in above-the-TCA incidents reappeared in below-the-TCA-floor reports. "The pilot asked if the light twin was in the TCA. I replied that it would depend on his exact altitude--if he were one foot above 3000 feet, then he was in the TCA." "The floor of the TCA was at 3000 feet so the other aircraft could have been legal at 2999 feet!"

GA Pilot Flight Policies and Perceptions. - Some VFR pilots appear to believe that 100 feet is an adequate buffer for flight beneath TCA floors. "Mindful of the 1500 foot TCA floor, I flew at 1400 feet." "I descended to 2900 feet which was beneath the 3000 foot floor." "Without even asking for my altitude (2900 feet), the controller stated that I was in the TCA (3000 feet)." An air carrier report: "I queried ATC about our near miss. Controller advised floor of the TCA was at 1900 feet and the other aircraft apparently was at 1800 feet." Other general aviation pilots indicated that planned tangential flight

tracks placed them within a fraction of a mile of curving TCA sidewalls. It is not known whether these pilots' perspectives and practices are typical of the GA community as a whole.

The squeeze of traffic into narrow altitude bands in canal-like passages winding through metropolitan areas beneath TCA floors is a matter of serious concern to some VFR reporters. "An accident waiting to happen" according to one reporter. "I've come to dread flying anywhere near this VFR corridor....It should be called 'suicide corridor!'" "I believe a serious hazard exists due to the compression of VFR traffic beneath the lateral TCA limits."

### **Differing Perceptions of TCA Airspace**

The foregoing data strongly suggest that fundamentally different ways of looking at TCAs (and possibly other types of restricted airspace) exist among segments of the aviation community. That IFR pilots, VFR pilots, and controllers may each view the subject uniquely is not surprising; the technologies the three use and the control environments in which they operate are different. These foster differing perceptions of the same airspace which increase the likelihood of conflicts within it.

The IFR Pilot's Perceptions. - As previously discussed, many IFR pilots appear to have only a vague knowledge of TCA dimensions. This may not seem a serious matter to them since they are usually under positive control. They simply comply with clearances from controllers who are assumed to understand the nuances of airspace boundaries.

However vague on exact dimensions, IFR airmen reports poignantly reveal their awareness of the TCA's existence as a protective mechanism. There is an extra edge of outrage in the phraseology of reports that describe a nerve-shattering traffic convergence and end with the notation (sometimes incorrect) that it happened in TCA airspace.

VFR Airmen's Perceptions. - Although fewer in relative number, reports from VFR airmen were similarly revealing. Two viewpoints predominate in their narratives.

First, the phraseology in many of the reports suggests that the writers view the TCA as merely a legal restriction on their freedom of action--not as the delimiter of a region of heightened real risk to themselves. Such pilots edge to a hundred feet or less of floor boundaries or fly tangential tracks only an eighth of a mile from curving TCA sidewalls. They seem much like motorists on a lightly trafficked freeway deciding to risk 10 mph over the posted speed limit. The risk considered is that of getting caught in a speed trap and fined; there is no sweaty-palmed fear of smashup simply because of the added increment of speed. For these pilots, the absence of fear vitiates the AIM's admonition against "operating too closely", and their flying practices drastically shrink the undefined buffer zone that one might hope the VFR flying community would create by complying with the AIM's earnestly worded advisory.

Second, phraseology in several reports coupled with common experience of individuals participating in this study effort give rise to the hypothesis that VFR airmen intuitively tend to conceive of the TCA as an envelope completely enclosing the in-the-TCA traffic. Such pilots might be surprised to learn that ATC routinely clears IFR aircraft to TCA floor and ceiling altitudes. This hypothesis has become a central feature of an additional ASRS study examining TCA incursions with specific reference to pilot perceptions of TCA airspace.

Controller's Perspective. - The FAA designs TCAs and its controllers have full jurisdiction over them. Controller reporters are obviously zealous in their efforts to perform in strict accord with ATC doctrine and prescribed procedures as they clear aircraft into and through the airspaces that they "own".

ATC partitions or "sectorizes" airspace for control purposes. Sectors are defined in terms of altitudes and lateral boundaries, and controllers assigned to sectors have exclusive control over them. In ATC parlance, a "high" sector might be spoken of as "owning" 11,000 feet on up, whereas the "low" sector beneath "owns" the altitudes up to and including 10,000, thereby creating a buffer zone of 1000 feet between the two sectors.

The notion of ownership is crucial here because it is clear from the evidence in this study dataset and the testimony of controller analysts who participated in the study, that from ATC's perspective it "owns" the floor and ceiling altitudes of TCAs. They are not



separating fences, as the VFR pilot community may view them; they are simply available operational altitudes routinely used by controllers. The matter-of-fact reference in the AIM to "...TCA aircraft at floor altitudes" underscores this conclusion.

## BUFFER ZONES

If all pilots accepted and complied with the AIM's advisories regarding flight near TCAs, a de facto buffer zone would exist at TCA boundaries. This study dataset contains incontrovertible evidence that there is an unknown but significant number of pilots who do not fly in this manner. We are not considering those who deliberately penetrate TCAs here--just those whose "close flying" policies collapse the AIM's advisory buffer. Accordingly, the possible redesign of TCAs to include formal buffer zones merits careful consideration.

## SUMMARY AND CONCLUSIONS

ASRS reports submitted by pilots and ATC controllers were examined with regard to two known problems associated with TCA boundary operations: (1) IFR/VFR traffic conflicts in airspace layers above TCA ceilings and below TCA floors (381 incidents); and (2) incursions into TCA terminal airspace by VFR aircraft (213 incidents).

The number of incidents reported over the seven-year period is modest, reflecting an undesirable but hardly dramatic level of hazard in view of the many millions of operations into or out of the 23 TCAs each year, but this study's principal concern was the causal dynamics of such events, not their frequency, and it succeeded in discovering a great deal in this regard. The study's principal conclusions and associated recommendations are as follows:

**The geographical pattern of boundary conflicts differs among TCAs. At some, almost all the conflicts were reported at above-TCA ceiling altitudes; at others, the majority took place below floor levels.**

Various factors influence the geography of boundary conflicts: locations of peripheral general aviation fields, the tailorings of TCA configurations in response to local operational needs, preferential runway use, ATC facility practices, STAR/SID procedures, etc. Comprehensive identification of TCA "hot spots" was beyond the scope of this study.

**Air carrier pilots frequently indicated uncertainty about TCA dimensions--particularly ceiling altitudes with their implied risk of VFR traffic conflicts. By contrast, VFR pilots often revealed precise knowledge of TCA boundaries.**

Awareness of TCA vertical and horizontal boundaries should be regarded as "must know", vital operational knowledge rather than mere "nice to know" information. Several reporters suggested that printing TCA ceiling heights on all SID charts could provide such critical information in air carrier cockpits.

**GA pilots expect the portions of TCA ceilings directly overhead main airport complexes to be untrafficked by outbound TCA traffic. However, some SIDs direct outbound IFR traffic into the thick of VFR traffic passing over the airport.**

Some SIDs require 180 degree climb reversals. IFR traffic flying these SIDs tends to emerge through TCA ceilings above the airports from which they originated into the heaviest flow of over-the-top VFR traffic. This appears to be an imprudent practice given GA pilot expectations and operational patterns.

**While the center portions of TCA ceilings are viewed as "GA country" (by GA pilots), air carrier pilots are equally possessive of the airspace surrounding the outer rims of TCA layers where the STAR descent corridors angle downward into the terminal areas. However, the typical descent paths of air transports are not depicted in the charts commonly carried by GA airmen.**

It appears that the general aviation community should be informed (perhaps via pictorial overlays on VFR Terminal Area Charts) as to the normal arrival routings of air carriers. Typical descent altitudes at such rim areas must be known to be avoided by VFR aircraft.

**Despite the AIM's counsel to VFR pilots circumnavigating TCAs, some VFR airmen cruise either at boundary altitudes or within a few hundred feet of them. Others fly tangential tracks which are planned to pass**

**within as little as one-eighth mile of TCA lateral boundaries. The de facto buffer zone which would exist if all VFR pilots heeded the AIM's admonitions is not a reality for this traffic.**

The question of whether a VFR aircraft is legally outside a TCA by a separation interval of 10, 50, or 100 feet would be but a narrow and meaningless technicality if, as one reporter bluntly phrased it, the pilot is "legal but dead". Some VFR airmen do not sense the hazard--only the legal issue.

**ATC "owns" the boundary altitudes of TCAs and uses them intensely as it ladders arriving traffic along the floors of the TCA. This fact is often missed by the VFR community.**

This ATC practice exacerbates the problem caused by VFR pilots' failures to give TCAs a wide berth. One airman plaintively asked: "Can someone give me a reason why this is necessary? Another 500 feet of altitude would make no difference to a jet's descent rate into final approach, yet it might save a midair."

**ATC's practice of running IFR aircraft along TCA boundaries is incompatible with VFR pilots' perception of these boundaries as impermeable traffic barriers. This is especially true when the IFR traffic is routed over active GA airfields or near heavily used VFR flyways. As long as this incompatibility persists there will be TCA boundary conflicts. It may be necessary to establish formal buffer zones to achieve comprehensive VFR/IFR traffic separation at TCA boundaries.**

This is the single most important conclusion arising from this study. Air carrier pilots, GA pilots, and ATC each have territorial attitudes towards the airspace which they use heavily, and also towards adjacent buffering airspace. Unfortunately, all three implicitly lay claim to the airspace adjoining TCA boundaries, this gives rise to conflicts, and creates a need for formal buffer zones to maintain separation among the claimants.

**Reports from GA pilots describing TCA incursions suggest that knowledge and training deficiencies were factors in many of the occurrences.**

Ninety of 213 TCA incursions included in this study were basically self-reported blunders by errant pilots who cited inexperience with TCA procedures, difficulties in reading TCA charts, unfamiliarity with the area, mix-ups regarding boundary landmarks, and so on. In

45 of these cases, the reporter was bound for, or had just taken off from, a nearby general aviation field. Required and recommended TCA operational practices may need to be more heavily emphasized during pilot training at all certification levels, but most especially when private pilots are licensed.

**When TCA incursions gave rise to conflicts, air carrier pilots were often caught "napping"; often there was little or no time for evasive action.**

Air carrier pilots depend upon the protection provided by TCAs and ATC radar services. When this protective cocoon is punctured it is a nerve-shattering experience and one which evokes considerable ire. This ire is directed at the VFR intruders, at the controllers who fail to advise of intruders' presence, and at FARs which permit aircraft to operate legally in TCA vicinities without operating transponders.

**Some GA airmen believe that they are treated as "second-class citizens" when they operate in and around TCAs. They complain of denied entries, rejected requests for traffic advisory services, off-course vectorings, and inability to obtain ATC responses to their radio call-ups. ATC refusals to permit GA IFR aircraft to track over the TCA ceilings on planned flight paths were particularly galling. GA pilots' frustration sometimes causes them to "opt-out" of the system. So they may turn off transponders, neglect to advise ATC of their presence in heavily used airspace, decline ATC services when they are available, and sometimes intentionally break the rules.**

Efforts to accommodate the needs of GA traffic wishing to transit or circumnavigate TCAs need to be increased. More constructive attitudes need to be fostered. Controller rejections of VFR requests for TCA transit or advisory services should be justified by valid workload considerations. When services are denied because of workload, this should be conveyed in standard phraseology employed for this purpose. Requests for ATC services should not be met with stony silence. At the same time, the VFR community needs to be better indoctrinated on controller duty priorities and the workloads controllers bear.

**The study dataset was rife with see-and-avoid failures. Air carrier and VFR pilots seemed equally at fault.**

GA reporters decried a lack of traffic vigilance in air carrier cockpits even as air carrier pilots noted that high workloads, both in climbs and in descents, reduced the frequency of traffic scans during TCA transitions. One VFR pilot, counseling his air carrier counterparts, summed up the situation well:

"Despite your workload pressures, nevertheless, you should know that an encoding transponder does not protect you from VFR aircraft....Putting your head down and reading checklists or perusing your 'How-to-fly' manual pages is not permissible....

"My plea is this: everyone, including the 'big boys', should be careful and alert when flying near TCA boundaries. Isn't this obvious?"

**Attachment A:**

**ACCESSION NUMBERS OF REPORTS USED IN THIS STUDY**

Penetrations, No Conflicts (90)

8641	8656	8789	8792	8896	9133	9237	9246
9976	10059	10598	10812	11091	11116	11612	11851
11978	12233	12593	12583	13135	13275	14278	14343
14351	14632	14701	14736	14722	14894	14938	14950
15037	15261	15326	15360	15484	15573	15669	16365
16510	16524	16634	16654	17339	17690	18207	18494
18733	19154	19319	19502	19637	19638	20612	20642
20790	21287	21300	21588	21980	22129	22236	22328
23253	23304	23390	23407	23612	23929	24686	24798
24960	26313	26785	27419	27482	28053	28139	28285
28696	28709	28877	28993	29031	29369	29389	29709
30189	30448						

Air Carrier/VFR Conflicts (137 of 253)

8862	8979	8992	9021	9030	9470	9568	9580
9844	9845	10346	10819	10884	10919	11061	11092
11226	11280	11314	11432	11827	11897	12030	12288
12426	12588	12737	12800	13372	13478	13777	13909
14186	14297	14757	14871	14906	15027	15050	15183
15261	15326	15360	15484	15493	15514	15533	15573
15647	15669	16069	16082	16221	16742	17022	17314
17336	17366	17543	17655	17841	17851	17902	18326
18654	18875	19587	19821	20042	20385	20589	20947
20981	21015	21114	21128	21301	21425	21469	21829
22055	22141	22257	22335	22961	22987	23044	23348
23510	23599	24099	24421	25015	25141	25346	25387
25587	25595	25657	25736	25686	25809	25823	25824
25843	25962	25970	26352	26422	26426	26464	26477
26701	26859	26956	27305	27712	27751	27785	28066
28470	28628	28672	28852	28859	28902	29316	29358
29794	30230	30251	30790	31088	31311	31418	31448
32324							

VFR/VFR (72)

8801	9514	9734	10728	10767	10824	10912	11396
11457	12207	12423	12514	13119	13422	13522	13726
14190	14801	15080	15102	15163	15314	15317	15320
15343	15447	15470	15629	15679	15955	16354	16719
17819	17820	18373	19498	19563	20089	20386	20365

VFR/VFR (continued)

20788	20888	20890	20891	21405	21506	22176	22320
22446	23619	23886	23890	24009	24029	24315	24832
25266	26586	26629	26721	27249	27571	27769	28306
28522	29119	29165	29341	29387	29452	30832	31496

Military/VFR Conflicts (42)

8761	8733	9324	9327	9341	9623	11314	11973
12319	13199	14540	15003	21179	21276	22718	23369
23693	24277	24256	24626	25213	25616	26096	26213
26261	26262	26265	26268	26448	26754	27001	27586
27596	27742	28400	28408	28415	28959	29293	29295
29867	30392						

Penetration Conflicts (122)

8778	9184	9246	9450	9532	10459	10526	10597
10768	10927	10943	10952	11221	11530	11811	12243
12378	12379	12582	12668	12953	12965	12791	13050
13440	13441	13495	13690	14105	14108	14278	14454
14531	14722	14801	14863	15037	15102	15360	15493
15514	15616	15871	15875	15955	16068	16633	16648
17000	17032	17341	17670	17745	17820	17818	17826
18134	18289	18290	18612	18657	19385	19423	19488
19584	19503	19563	20234	20287	20298	20447	20542
20744	20808	20988	21422	21467	21673	21746	21767
21830	21949	21993	22262	22246	22535	22927	23275
23643	23713	23842	23886	23921	23929	23979	24029
24686	24798	25132	25177	25386	26311	26393	26460
26523	26553	26590	26635	26701	27295	28483	28650
28924	28925	29061	29346	29357	29699	29790	30662
31457	31517						

Air Carrier/VFR Conflicts Below TCA (116 of 253)

9077	9684	9813	9838	9893	9933	10202	10220
10316	10320	10378	10418	10438	10767	10883	11077
11108	11205	11232	11392	11719	11790	11943	11973



Air Carrier/VFR Conflicts Below TCA (continued)

12078	12083	12207	12869	13392	13462	13587	14030
14152	14707	14765	14838	14889	14901	15183	15520
15723	15749	15947	15954	16075	16114	16223	16265
16365	16566	16523	16633	16648	16729	17106	17132
17414	17578	17657	17854	18267	19200	19338	19853
19906	20096	20382	20466	20672	20798	20804	21101
21505	21527	21602	22413	22415	23283	23718	23929
24322	24687	24706	24832	25140	25277	25318	25476
25550	25877	26151	26362	26632	26647	26817	27251
27393	27466	28130	28233	28280	28492	28498	28519
28686	28970	29164	29166	29179	29343	29345	29435
29775	29535	29631	30832				

1. Report No. NASA CR-177522		2. Government Accession No.		3. Recipient's Catalog No.	
4. Title and Subtitle Human Factors in Aviation: Terminal Control Area Boundary Conflicts				5. Report Date February 1989	
				6. Performing Organization Code	
7. Author(s) Captain William P. Monan				8. Performing Organization Report No.	
9. Performing Organization Name and Address Battelle Columbus Division, ASRS Office 625 Ellis Street, Suite 305 Mtn. View, CA 94043				10. Work Unit No. 49	
				11. Contract or Grant No. NAS2-11934	
12. Sponsoring Agency Name and Address National Aeronautics and Space Administration Ames Research Center Moffett Field, CA 94035				13. Type of Report and Period Covered	
				14. Sponsoring Agency Code	
15. Supplementary Notes Point of Contact: William D. Reynard, M/S 239-1 NASA Ames Research Center Moffett Field, CA 94035 (415) 694-6467					
16. Abstract Air-to-air conflicts in the vicinity of TCA boundaries were studied to obtain a better understanding of the causal dynamics of these events with particular focus on human factor issues. The study dataset consisted of 381 IFR/VFR traffic conflicts in airspace layers above TCA ceilings and below TCA floors; 213 reports of incursions in TCA terminal airspace by VFR aircraft, of which 123 resulted in conflicts; and an additional set of reports describing problems with ATC services in and around TCAs.  Findings indicate that 1) The geographical pattern of boundary conflicts differs among TCAs depending on the specific flow patterns of arriving and departing air carrier traffic; 2) Air carrier pilots are frequently uncertain about TCA dimensions, in contrast to VFR pilots who more frequently possess precise knowledge of TCA boundaries; 3) GA pilots expect the portions of TCA ceilings directly overhead main airport complexes to be untrafficked by outbound TCA traffic, an expectation that appears imprudent given some SID routings that direct outbound IFR traffic into the heaviest flow of over-the-top VFR traffic; 4) GA pilots commonly do not carry charts that depict the typical descent paths (STAR descent corridors) of air transports through outer TCA rims into the terminal areas; 5) many VFR airmen select cruising altitudes near TCA floor or ceiling altitudes, ignoring the AIM's caution against "operating too closely"; 6) Many in the VFR community seem unaware that ATC intensively uses the boundary altitudes of TCAs and considers itself to "own" these altitudes; 7) Reports from GA pilots describing TCA incursions suggest that knowledge and training deficiencies were factors in many of these occurrences; 8) Air carrier pilots were often caught "napping" when TCA incursions gave rise to conflicts, with often little or no time for evasive action; 9) Some GA pilots believe that they are treated as "second-class citizens" when they operate in and around TCAs, and their resultant frustration may lead them to "opt-out" of the system; 10) Failures of the see-and-avoid concept were a feature of many of the conflict incidents.					
17. Key Words (Suggested by Author(s)) Aircraft conflicts Airspace boundary, incursions Aviation human factors, safety Terminal control area			18. Distribution Statement Unlimited		
19. Security Classif. (of this report) Unclassified		20. Security Classif. (of this page) Unclassified		21. No. of Pages 35	22. Price*

\*For sale by the National Technical Information Service, Springfield, Virginia 22161