

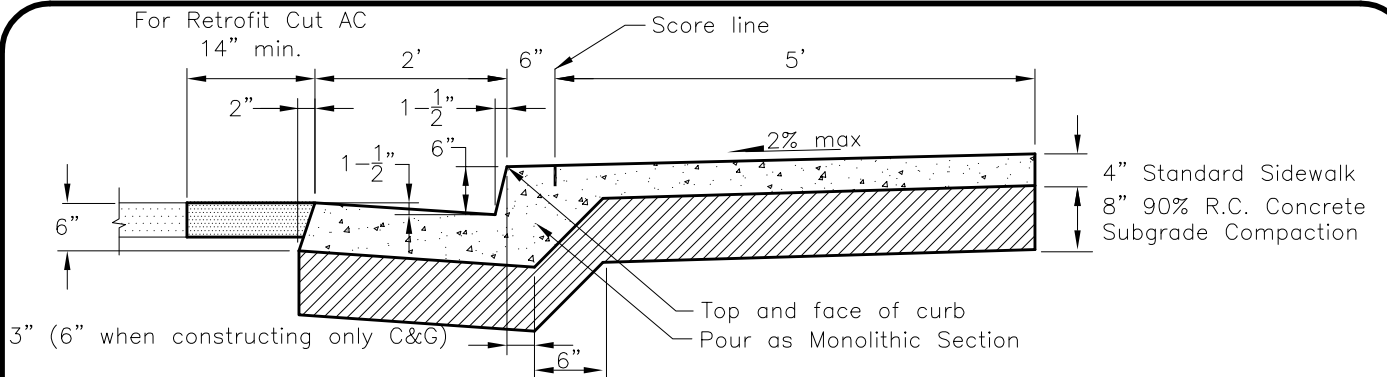

# CITY OF LODI

PUBLIC WORKS DEPARTMENT

## Vertical-Type Curb, Gutter, Sidewalk and Residential Driveway



Curb, Gutter, & Sidewalk Section

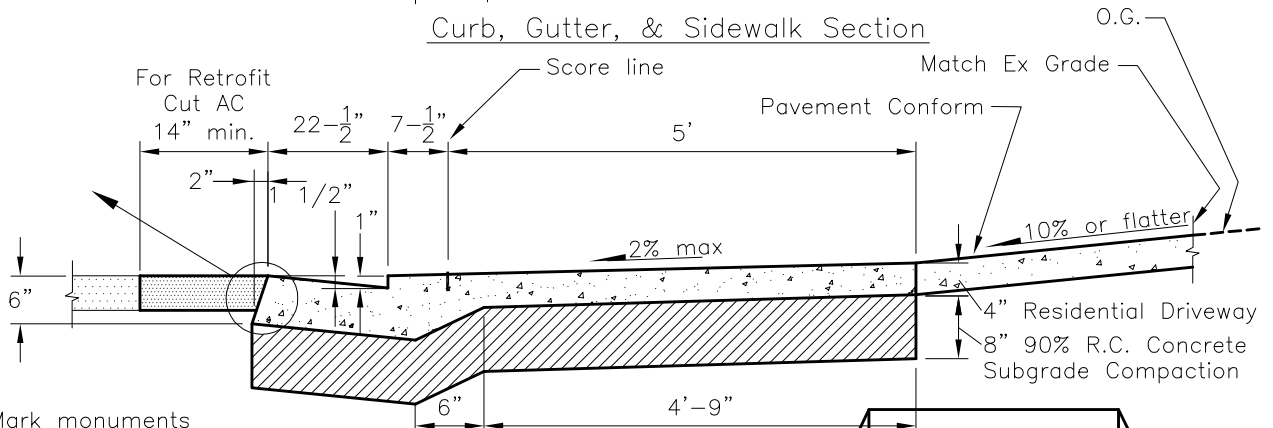

Residential Driveway Section

Bench Mark monuments will be furnished by the City of Lodi, when required, and shall be installed by the contractor as directed by City Engineer

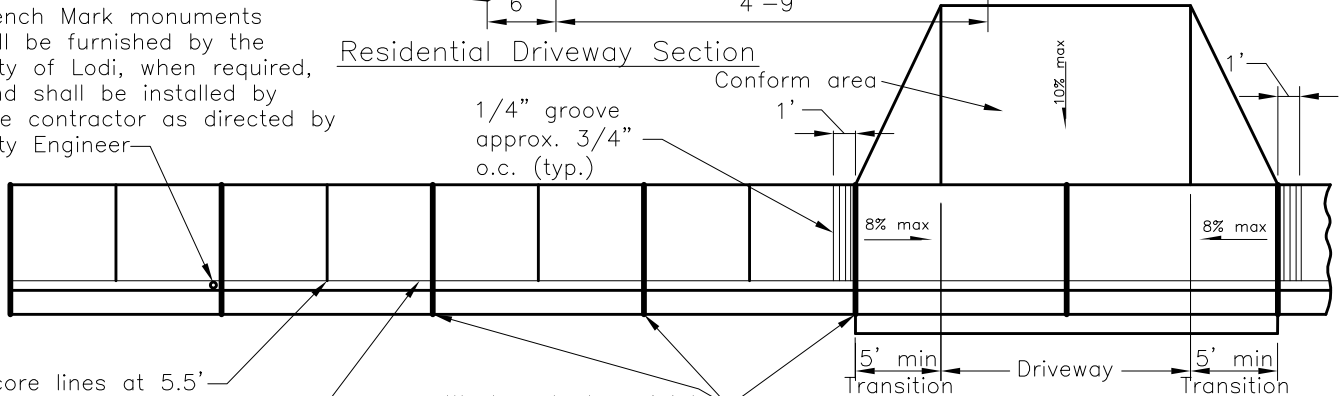

Plan

Notes:

1. Construct weakened plane joints at 11' and at ends of transitions & centerline of driveway.
2. Use impervious membrane cure. Broom finish.
3. Class B concrete per Section 90 of Std. Spec., 1-1/2" max. aggregate.
4. Construct expansion material at 200' max.
5. All exposed edges shall be rounded to 1/2" radius.

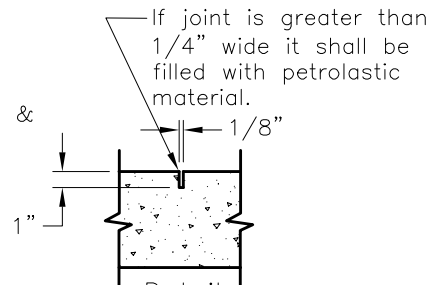

Detail  
Weakened Plane Joint

Dr. KT	No.	Date	Revision	Appr.
	1	9/03	ADDED CURB HEIGHT	
Ch. WS	2	9/07	MINOR REVISIONS	
Date		9/08		

Approved By: *F. Wally Sandelin*  
 F. Wally Sandelin  
 City Engineer  
 R.C.E. 39895  
 Date: 9/07

STD PLAN  
**135**