

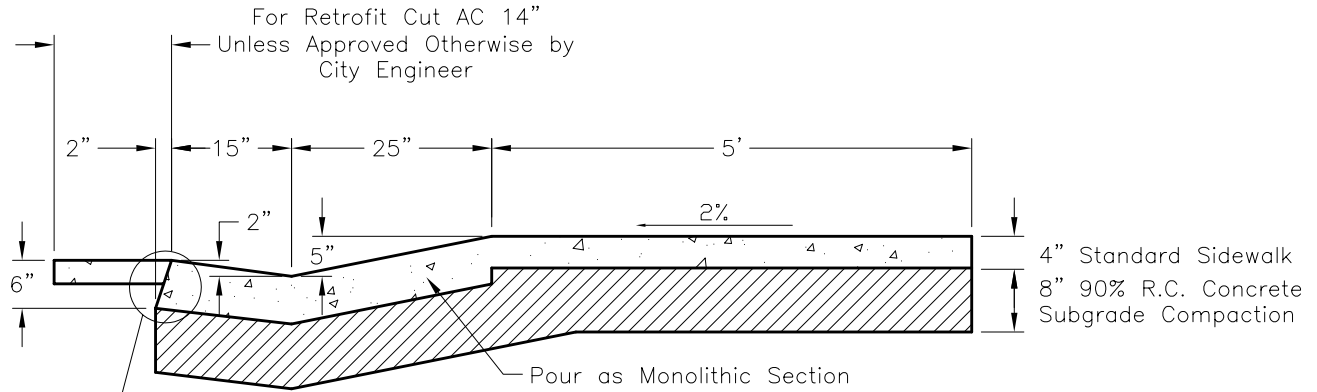

# CITY OF LODI

PUBLIC WORKS DEPARTMENT

## Driveway-Type Curb, Gutter & Sidewalk



Curb, Gutter, & Sidewalk Section

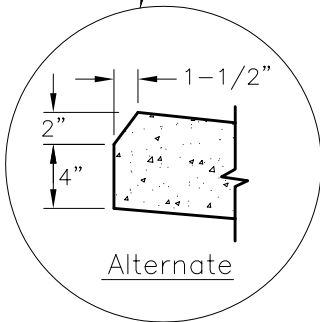

Alternate

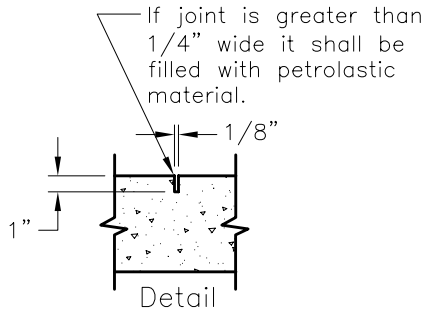

Detail

Weakened Plane Joint

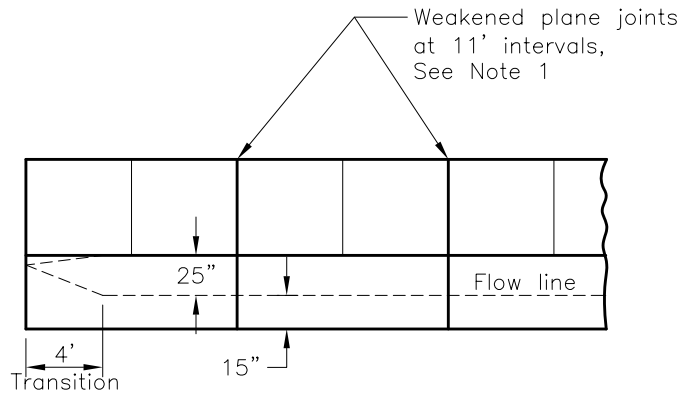

Plan

Notes:

1. Construct weakened plane joints at 11' interval to match score lines.
2. Use impervious membrane cure. Broom finish.
3. Class B concrete per Section 90 of Std. Spec., 1-1/2" max. aggregate.
4. Construct expansion joints at 200' max.
5. All exposed edges shall be rounded to 1/2" radius.

Dr. KT	No.	Date	Revision	Appr.	Approved By:	STD PLAN
Ch. WS					<i>F. Wally Sandelin</i>	113A
Date 12/00					F. Wally Sandelin City Engineer R.C.E. 39895	12/28/00 Date