

CALLBACK

ASRS

From NASA's Aviation Safety Reporting System

Number 309

June 2005

What Would You Have Done ?

As in previous "interactive" issues of Callback, readers are once again given the opportunity to consider an appropriate course of action for a given situation. The actions that were actually taken by the reporters of these incidents are found on the reverse of this Callback issue. Bear in mind that the reported action may or may not represent the best response to the situation. Our intent is to stimulate thinking, discussion, and training related to the type of incidents that were reported.

Situation #1: The propeller struck the sand and stopped the engine."

After experiencing some difficulties landing on a remote beach, this C172 pilot had to decide whether or not his aircraft was fit to fly out.

■ ... I was eager to explore more landing areas nearer to a good fishing hole. After a few exploratory low passes, I saw what I thought was a suitable landing area. As I set the main wheels down, I held full aft elevator to slow the aircraft. When I lost elevator effectiveness the nosewheel touched down and began to sink in the sand. In a few more seconds the aircraft came to a stop with the nosewheel buried in the sand. The propeller struck the sand and stopped the engine. My passenger and I were able to free the aircraft and pushed it a few feet toward the sea to more stable soil. I inspected the propeller and it did not appear to be bent. I started the engine and noticed a slight vibration that smoothed out when full power was applied.

What would you have done?

Situation #2: "A decision had to be made."

This non-instrument rated, Cessna 206 pilot was faced with a classic weather decision: press on in hopes that conditions would improve, or accept the inconvenience of an enroute stop.

■ I contacted the local Flight Service Station and requested information about the weather from [departure airport] to ZZZ, my destination. I was informed that a stalled stationary front included ZZZ and current conditions there were IFR. I departed VFR and tracked the weather via numerous AWOS/ASOS reports during flight. Approximately 100 miles south of ZZZ the weather was deteriorating.

I had to catch a commercial flight at my destination and, although it was still IFR there, I believed that conditions would surely improve. Enroute, YYY was reporting Marginal VFR and a decision had to be made whether or not to continue to ZZZ.

What would you have done?

ASRS Alerts Issued in May 2005	
Subject of Alert	No. of Alerts
Aircraft or aircraft equipment	4
Airport facility or procedure	3
ATC procedure or equipment	1
Chart, Publication, or Nav Database	2
Maintenance procedure	4
Total	14

A Monthly Safety Bulletin from

The Office of the NASA Aviation Safety Reporting System, P.O. Box 189, Moffett Field, CA 94035-0189

<http://asrs.arc.nasa.gov/>

Situation #3: "I can make this."

This A320 First Officer was prepared to abandon an unstable approach, but then it started to look like things might work out.

■ ...ATC gave us a close-in turn from downwind to base leg in visual conditions. The Captain and I both anticipated a "slam dunk" from Approach Control so we had slowed to approximately 170 knots and set flaps 2. The situation was further compounded when Approach told us to maintain 5,000 feet for traffic in the area. We were cleared for the visual four miles from the runway at 5,000 feet. I began a very rapid descent with gear down, flaps 3, and speed brakes full. I was determined to give this my best effort, however I mentally prepared myself for a go-around. I told the Captain that at 1,000 feet I thought we should evaluate the situation. At around 1,000 feet I began to capture the glideslope, prompting me to continue the approach even though the airspeed was still high. At around 500 feet airspeed began to decrease, further tempting me to think, "I can make this!"

What would you have done?

Situation #4: "The Cessna was between him and the airport."

Faced with one aircraft that needed to make an emergency approach and another aircraft that presented a traffic conflict, this Air Traffic Controller had to orchestrate a solution.

■ The Mooney (9,000 feet) was northbound.... The Cessna (8,000 feet) was eastbound. When the Mooney was three or four miles south of the Cessna, he indicated that he had an engine problem and wanted to land at ZZZ. This required that he descend visually through the Cessna's altitude or be vectored away for standard separation. The airport was only 10 miles away and the Cessna was between him and the airport. The winds were strong from the north, so he wanted to set up for an approach. I called out the traffic twice and kept the Mooney level, hoping he would see the Cessna. I felt that the Mooney needed me to get him down, so he could set up his approach.

As the controller, what would you have done?

May 2005 Report Intake

Air Carrier / Air Taxi Pilots	2408
General Aviation Pilots	854
Controllers	42
Cabin/Mechanics/Military/Other	174
TOTAL	3478

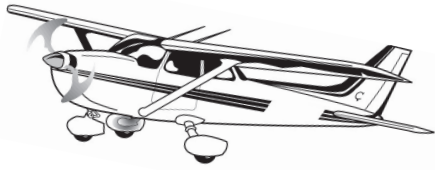

Situation #1: “The propeller struck the sand and stopped the engine.”

I decided that I would fly the aircraft home, because what little damage there was would not affect the airworthiness of the aircraft. When I returned the aircraft to the FBO where I had rented it they decided to send the prop off for balancing. They also removed the engine and sent it off for a mandatory tear-down and inspection. My biggest regret from this incident is that I allowed myself to explore and attempt less and less suitable landing areas to the point where I finally damaged a very nice airplane. At some point I should have set a limit for myself and not have landed a \$100,000 airplane on the beach for fun. Taking off with a damaged engine and prop was also poor judgment.



Situation #2: “A decision had to be made.”

I continued toward ZZZ.... Conditions remained Marginal VFR until 30-40 miles south of ZZZ. The weather rapidly deteriorated and I had to be vectored around a thunderstorm. I knew at this point that I had made a wrong decision. I was now risking my life and was wishing I had landed at YYY.... After discussion with Approach Control at ZZZ and with fuel becoming a consideration, I was vectored to an ILS approach at ZZZ. With the help of an experienced pilot giving direction, a safe landing was made.

I have been flying for a number of years. I learned a valuable lesson on how fast weather can close in; how stupid it is to “assume” that the weather will clear. I used very poor judgment and made a decision I feel was influenced by the fact that I had a commercial plane to catch....



Situation #3: “I can make this.”

I didn't take the bait. I set TOGA (Takeoff and Go Around) power and performed a go-around at 500 feet. ATC vectored us back for a normal landing. This situation showed me how easy it is to continue with an unstable approach because, when you begin to catch up with the situation, you encourage yourself to continue further and further down that unstable path which can lead to an unstable landing...or worse. I kept myself from completely falling into the trap by mentally preparing for the go-around ahead of time and not committing to the landing until stable approach parameters were met. I also believe that we sometimes accept instructions from ATC that may be difficult to perform because we don't want to cause a problem or look like we aren't good enough to handle the situation.

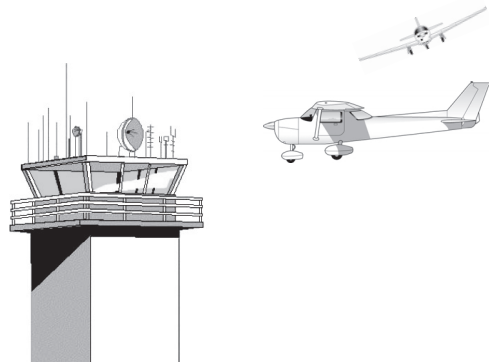

Situation #4: “The Cessna was between him and the airport.”

I declared an emergency for the Mooney as I felt time and distance were becoming critical. I descended him and it all worked out fine in the end. But the aircraft should have either indicated he was OK with being maneuvered at altitude for the traffic, or taken his own decision to descend. I felt trapped by the rules. The pilot should have been more forceful if he needed lower or been more explicit that he could wait for the traffic.

Yes, a controller can declare an emergency for the pilot. And speaking of pilots' reluctance to use the “E” word, that will be the subject of an upcoming issue of CALLBACK.